

# TM 10-3930-638-24

---

## TECHNICAL MANUAL

### FIELD AND SUSTAINMENT MAINTENANCE MANUAL

FOR

**TRUCK, FORKLIFT, DED,  
PNEUMATIC TIRE, ARTICULATED  
FRAME STEER, 4,000 LB CAPACITY  
ROUGH TERRAIN, ARMY MODEL MHE 237  
(J.I. CASE MODEL M4K)  
(NSN 3930-01-076-4237)**

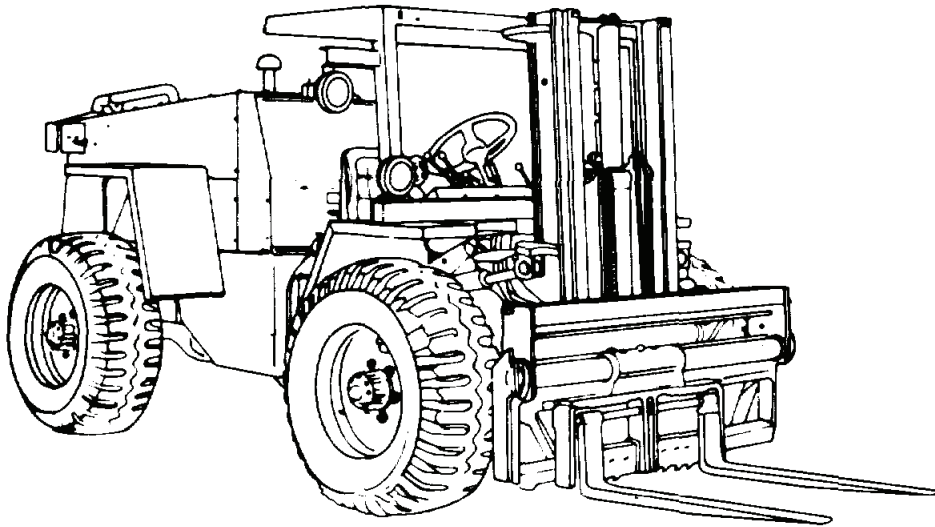

\*Supersedes TM 10-3930-638-24&P dated 1 October 1980, including all changes.

**DISTRIBUTION STATEMENT A** - Approved for public release; distribution is unlimited.

---

**HEADQUARTERS, DEPARTMENT OF THE ARMY**

JULY 2008



## WARNING SUMMARY

This warning summary contains general safety warnings and hazardous materials warnings that must be understood and applied during operation and maintenance of this equipment. Failure to observe these warnings could result in serious injury or death to personnel.

The following are explanations of safety and hazardous materials icons:



**BIOLOGICAL** - abstract symbol bug shows that a material may contain bacteria or viruses that present a danger to life or health.



**CHEMICAL** - drop of liquid on hand shows that the material will cause burns or irritation to human skin or tissue.



**EAR PROTECTION** - headphones over ears show that noise level will harm ears.



**ELECTRICAL** - electrical wire to arm with electricity symbol running through human body shows that shock hazard is present.



**EYE PROTECTION** - person with goggles shows that the material will injure the eyes.



**FIRE** - flame shows that a material may ignite and cause burns.



**FLYING PARTICLES** - arrows bouncing off face with face shield shows that particles flying through the air will harm face.



**LIFTING HEAVY OBJECT** - human figure stooping over heavy object shows physical injury potential from improper lifting technique.



HEAVY PARTS - hand with heavy object on top shows that heavy parts can crush and harm.



HEAVY PARTS - heavy object on human figure shows that heavy parts present a danger to life or limb.



HEAVY PARTS - heavy object pinning human figure against wall shows that heavy, moving parts present a danger to life or limb.



HOT AREA - hand over object radiating heat shows that part is hot and can burn.



HYDRAULIC FLUID PRESSURE - hydraulic fluid spraying human hand shows that fluid escaping under great pressure can cause injury or death to personnel.



RADIOACTIVE - identifies a material that emits radioactive energy and can injure human tissue or organs.



SLICK FLOOR - wavy line on floor with legs prone shows that slick floor presents a danger from falling.



VAPOR - human figure in a cloud shows that material vapors present a danger to life or health.

## FOR INFORMATION ON FIRST AID, REFER TO FM 4-25.11.



### WARNING

#### ***CARBON MONOXIDE (EXHAUST GASES) CAN KILL!***

- Carbon monoxide is a colorless, odorless, deadly poison which, when breathed, deprives the body of oxygen and causes suffocation. Exposure to air containing carbon monoxide produces symptoms of headache, dizziness, loss of muscular control, apparent drowsiness, and coma. Permanent brain damage or death can result from severe exposure.
  - Carbon monoxide occurs in exhaust fumes of internal combustion engines. Carbon monoxide can become dangerously concentrated under conditions of inadequate ventilation. The following precautions must be observed to ensure safety of personnel when an internal combustion engine is operated.
1. DO NOT operate engine in enclosed areas.
  2. DO NOT idle engine without adequate ventilation.
  3. DO NOT operate engine with inspection plates or cover shields removed.
  4. BE ALERT for exhaust poisoning symptoms. They are:
    - Headache
    - Dizziness
    - Sleepiness
    - Loss of muscular control
  5. If you see another person with exhaust poisoning symptoms:
    - Remove person from area.
    - Expose to fresh air.
    - Keep person warm.
    - DO NOT permit physical exercise.
    - Administer Cardiopulmonary Resuscitation (CPR), if necessary.
    - Notify a medic.
  6. BE AWARE. The field protective mask for Nuclear, Biological, and Chemical (NBC) protection will not protect you from carbon monoxide poisoning.

***The Best Defense Against Carbon Monoxide Poisoning Is Good Ventilation!***



**WARNING**  
**BATTERIES**



- To avoid injury, eye protection and acid-resistant gloves must be worn when working around batteries. DO NOT smoke, use open flame, make sparks, or create other ignition sources around batteries. If a battery is giving off gases, it can explode and cause injury to personnel. Remove all jewelry such as rings, ID tags, watches, and bracelets. If jewelry or a tool contacts a battery terminal, a direct short will result in instant heating or electric shock, damage to equipment, and injury to personnel.
- Sulfuric acid contained in batteries can cause serious burns. If battery corrosion or electrolyte makes contact with skin, eyes or clothing, take immediate action to stop the corrosive burning effects. Failure to follow these procedures may result in death or serious injury to personnel.
  - a. **Eyes.** Flush with cold water for no less than 15 minutes and seek medical attention immediately.
  - b. **Skin.** Flush with large amounts of cold water until all acid is removed. Seek medical attention as required.
  - c. **Internal.** If corrosion or electrolyte is ingested, drink large amounts of water or milk. Follow with milk of magnesia, beaten egg, or vegetable oil. Seek medical attention immediately.
  - d. **Clothing/Equipment.** Wash area with large amounts of cold water. Neutralize acid with baking soda or household ammonia.



**WARNING**

**CALIFORNIA - PROPOSITION 65**

Engine exhaust and some of its constituents, batteries and some of their constituents, and some dust created by power sanding, sawing, grinding, drilling, and other construction activities contain chemicals known to the State of California to cause cancer, birth defects, and other reproductive harm. Some examples of these chemicals are:

- Lead from batteries, battery terminals, and posts.
- Lead from lead-based paints.
- Cement and other masonry products.
- Arsenic and chromium from chemically treated lumber.

Your risk from these exposures varies, depending on how often you do this type of work. To reduce exposure to these chemicals:

- ALWAYS work in a well-ventilated area.
- Work with approved safety equipment, such as gloves and dust masks that are specially designed to filter out microscopic particles.



**WARNING**

***COMPRESSED AIR***

Particles blown by compressed air are hazardous. DO NOT exceed 15 PSI (103 kPa) nozzle pressure when drying parts with compressed air. DO NOT exceed 30 PSI (207 kPa) nozzle pressure when cleaning parts with compressed air. DO NOT direct compressed air against human skin. Failure to follow this warning may result in injury to personnel. Make sure air stream is directed away from user and other personnel in the area. To prevent injury, user must wear protective goggles or face shield.



**WARNING**

***ELECTRICAL SHOCK HAZARD***

Always disconnect battery ground cable before working on electrical components of this equipment. Failure to follow this warning may result in injury or death to personnel.



**WARNING**

***FALLING EQUIPMENT HAZARD***

NEVER crawl under equipment when performing maintenance unless equipment is blocked securely. Keep clear of equipment when it is raised or lowered. DO NOT allow heavy components to swing while suspended by lifting device. Exercise extreme caution when working near a cable or chain under tension. Failure to follow this warning may result in injury or death to personnel.



**WARNING**

***FUEL HANDLING***

- DO NOT perform fuel system checks, inspections, or maintenance while smoking or near fire, flames, or sparks. Fuel may ignite, causing injury or death to personnel or damage to equipment.
- Operating personnel must wear fuel-resistant gloves when handling fuels. If exposed to fuel, promptly wash exposed skin and change fuel-soaked clothing. Failure to follow this warning may result in injury to personnel.



**WARNING**

**HAZARDOUS WASTE DISPOSAL**



- When servicing this vehicle, performing maintenance, or disposing of materials such as engine coolant, hydraulic fluid, lubricants, battery acids or batteries, and CARC paint, consult your unit/local hazardous waste disposal center or safety office for local regulatory guidance. If further information is needed, please contact The Army Environmental Hotline at 1-800-872-3845.
- Lubricating/hydraulic oils and engine coolant used in the performance of maintenance can be very slippery. Immediately wipe up any spills. Failure to follow this warning may result in injury to personnel.



**WARNING**

**HEARING PROTECTION**

Your hearing can be **PERMANENTLY DAMAGED** if you are exposed to constant high noise levels of 85 dB or greater. Hearing protection is required when operating vehicle or when working on vehicle while it is operating. Failure to wear hearing protection may result in hearing loss.



**WARNING**

**NBC EXPOSURE**



If NBC exposure is suspected, all air filter media should be handled by personnel wearing protective equipment. Consult your unit NBC Officer or NBC NCO for appropriate handling or disposal procedures.

**WARNING**

**OPERATION OF VEHICLE**

- **BE ALERT** for personnel in the area while operating vehicle. Always check to ensure area is clear of personnel and obstructions before moving. Failure to follow this warning may result in injury or death to personnel.
- Use of seat belt while operating vehicle is mandatory. Fasten belt **BEFORE** operating vehicle. Trying to fasten belt during operation creates a hazardous condition. Failure to follow this warning may result in injury or death to personnel.
- **DO NOT** allow riders on vehicle. Failure to follow this warning may result in injury or death to personnel.
- **NEVER** leave operator compartment without applying parking brake. Failure to follow this warning may result in injury or death to personnel.
- **DO NOT** use parking/emergency brake to stop a moving vehicle under usual conditions. Only if service brakes fail, apply parking/emergency brake. Failure to follow this warning may result in injury to personnel or damage to equipment.





**WARNING**  
***PINCH POINTS***

Use extreme caution when manually adjusting position of lifting forks. Avoid crushing fingers or hands by keeping hands away from pinch points. Failure to do so may result in serious injury.



**WARNING**  
***PRESSURIZED COOLING SYSTEM***



- DO NOT service cooling system unless engine has been allowed to cool down. This is a pressurized cooling system and escaping steam or hot coolant may result in serious burns.
- DO NOT remove cooling system radiator cap when engine is hot. Allow engine to cool down. Loosen cap to first stop and let any pressure out of cooling system, then remove cap. Failure to follow this warning may result in serious burns.
- Wear effective eye, hand, and skin protection when handling coolants. Failure to do so may result in injury to personnel.



**WARNING**  
***PRESSURIZED HYDRAULIC SYSTEM***



2,500 PSI PRESSURE is used to operate this equipment. NEVER disconnect any hydraulic lines or fittings without checking manual to see how to drop the pressure to zero. Failure to follow this warning may result in injury or death to personnel.



**WARNING**  
***SOLVENT CLEANING COMPOUND***



Solvent cleaning compound MIL-PRF-680 Type III is an environmentally compliant and low toxic material. However, it may be irritating to the eyes and skin. Use protective gloves and goggles. Use in well-ventilated areas. Keep away from open flames and other sources of ignition. Failure to do so may result in injury or death to personnel.

## WARNING

### *TIRES*

- Observe caution when inflating tires. Be sure tires are properly seated on rims before inflating. Failure to follow this warning may result in injury or death to personnel. Improperly seated tires can burst with explosive force sufficient to cause death.
- Deflate tire completely before removing wheel from rim. Refer to manual to completely deflate tire. Failure to follow this warning may result in injury or death to personnel.



WARNING  
*WORK SAFETY*



- Lifting cables, chains, hooks, and slings used for lifting equipment must be in good condition and of suitable capacity. Failure to follow this warning may result in injury or death to personnel or damage to equipment.
- Use extreme caution when handling heavy parts. Provide adequate support and use assistance during procedure. Ensure that any lifting device used is in good condition and of suitable load capacity. Keep clear of heavy parts supported only by lifting device. Failure to follow this warning may result in injury or death to personnel.
- Hot oil or metal parts can cause severe burns. Wear insulated gloves, long sleeves, and eye protection when working with heated parts.

**LIST OF EFFECTIVE PAGES/WORK PACKAGES**

NOTE: Zero in the “Change No.” column indicates and original page or work package.

Date of issue for the original manual is:

Original....15 July 2008

Total number of pages for front and rear matter is 38 and total number of work packages is 310, consisting of the following:

<b>Page/WP No.</b>	<b>Change No.</b>	<b>Page/WP No.</b>	<b>Change No.</b>
Front Cover (2 pgs.) . . . . .	0	WP 0031 (6 pgs.) . . . . .	0
Warning Summary (8 pgs.) . . . . .	0	WP 0032 (16 pgs.) . . . . .	0
Table of Contents (12 pgs.) . . . . .	0	WP 0033 (4 pgs.) . . . . .	0
Chapter 1 title page		WP 0034 (4 pgs.) . . . . .	0
WP 0001 (2 pgs.) . . . . .	0	WP 0035 (2 pgs.) . . . . .	0
WP 0002 (10 pgs.) . . . . .	0	WP 0036 (2 pgs.) . . . . .	0
WP 0003 (8 pgs.) . . . . .	0	WP 0037 (2 pgs.) . . . . .	0
Chapter 2 title page		WP 0038 (2 pgs.) . . . . .	0
WP 0004 (2 pgs.) . . . . .	0	WP 0039 (2 pgs.) . . . . .	0
WP 0005 (4 pgs.) . . . . .	0	WP 0040 (2 pgs.) . . . . .	0
WP 0006 (14 pgs.) . . . . .	0	WP 0041 (4 pgs.) . . . . .	0
WP 0007 (4 pgs.) . . . . .	0	WP 0042 (2 pgs.) . . . . .	0
WP 0008 (2 pgs.) . . . . .	0	WP 0043 (12 pgs.) . . . . .	0
WP 0009 (2 pgs.) . . . . .	0	Chapter 4 title page	
WP 0010 (2 pgs.) . . . . .	0	WP 0044 (4 pgs.) . . . . .	0
WP 0011 (2 pgs.) . . . . .	0	WP 0045 (4 pgs.) . . . . .	0
WP 0012 (4 pgs.) . . . . .	0	WP 0046 (4 pgs.) . . . . .	0
WP 0013 (2 pgs.) . . . . .	0	WP 0047 (2 pgs.) . . . . .	0
WP 0014 (2 pgs.) . . . . .	0	WP 0048 (2 pgs.) . . . . .	0
WP 0015 (2 pgs.) . . . . .	0	WP 0049 (2 pgs.) . . . . .	0
WP 0016 (2 pgs.) . . . . .	0	WP 0050 (2 pgs.) . . . . .	0
WP 0017 (8 pgs.) . . . . .	0	WP 0051 (2 pgs.) . . . . .	0
WP 0018 (2 pgs.) . . . . .	0	WP 0052 (2 pgs.) . . . . .	0
WP 0019 (4 pgs.) . . . . .	0	WP 0053 (6 pgs.) . . . . .	0
WP 0020 (2 pgs.) . . . . .	0	WP 0054 (4 pgs.) . . . . .	0
WP 0021 (10 pgs.) . . . . .	0	WP 0055 (6 pgs.) . . . . .	0
WP 0022 (2 pgs.) . . . . .	0	WP 0056 (4 pgs.) . . . . .	0
WP 0023 (4 pgs.) . . . . .	0	WP 0057 (2 pgs.) . . . . .	0
WP 0024 (2 pgs.) . . . . .	0	WP 0058 (2 pgs.) . . . . .	0
WP 0025 (2 pgs.) . . . . .	0	WP 0059 (6 pgs.) . . . . .	0
WP 0026 (4 pgs.) . . . . .	0	WP 0060 (6 pgs.) . . . . .	0
WP 0027 (2 pgs.) . . . . .	0	WP 0061 (6 pgs.) . . . . .	0
Chapter 3 title page		WP 0062 (6 pgs.) . . . . .	0
WP 0028 (2 pgs.) . . . . .	0	WP 0063 (4 pgs.) . . . . .	0
WP 0029 (4 pgs.) . . . . .	0	WP 0064 (4 pgs.) . . . . .	0
WP 0030 (6 pgs.) . . . . .	0	WP 0065 (4 pgs.) . . . . .	0

Page/WP No.	Change No.	Page/WP No.	Change No.
WP 0066 (4 pgs.)	0	WP 0106 (4 pgs.)	.0
WP 0067 (2 pgs.)	0	WP 0107 (4 pgs.)	.0
WP 0068 (2 pgs.)	0	WP 0108 (4 pgs.)	.0
WP 0069 (6 pgs.)	0	WP 0109 (4 pgs.)	.0
WP 0070 (4 pgs.)	0	WP 0110 (4 pgs.)	.0
WP 0071 (4 pgs.)	0	WP 0111 (6 pgs.)	.0
WP 0072 (4 pgs.)	0	WP 0112 (4 pgs.)	.0
WP 0073 (4 pgs.)	0	WP 0113 (6 pgs.)	.0
WP 0074 (6 pgs.)	0	WP 0114 (6 pgs.)	.0
WP 0075 (8 pgs.)	0	WP 0115 (4 pgs.)	.0
WP 0076 (8 pgs.)	0	WP 0116 (4 pgs.)	.0
WP 0077 (6 pgs.)	0	WP 0117 (4 pgs.)	.0
WP 0078 (4 pgs.)	0	WP 0118 (4 pgs.)	.0
WP 0079 (4 pgs.)	0	WP 0119 (4 pgs.)	.0
WP 0080 (2 pgs.)	0	WP 0120 (4 pgs.)	.0
WP 0081 (4 pgs.)	0	WP 0121 (4 pgs.)	.0
WP 0082 (8 pgs.)	0	WP 0122 (6 pgs.)	.0
WP 0083 (6 pgs.)	0	WP 0123 (4 pgs.)	.0
WP 0084 (4 pgs.)	0	WP 0124 (4 pgs.)	.0
WP 0085 (4 pgs.)	0	WP 0125 (4 pgs.)	.0
WP 0086 (4 pgs.)	0	WP 0126 (2 pgs.)	.0
WP 0087 (2 pgs.)	0	WP 0127 (4 pgs.)	.0
WP 0088 (4 pgs.)	0	WP 0128 (4 pgs.)	.0
WP 0089 (4 pgs.)	0	WP 0129 (4 pgs.)	.0
WP 0090 (2 pgs.)	0	WP 0130 (4 pgs.)	.0
WP 0091 (4 pgs.)	0	WP 0131 (4 pgs.)	.0
WP 0092 (4 pgs.)	0	WP 0132 (4 pgs.)	.0
WP 0093 (6 pgs.)	0	WP 0133 (6 pgs.)	.0
WP 0094 (6 pgs.)	0	WP 0134 (6 pgs.)	.0
WP 0095 (6 pgs.)	0	WP 0135 (4 pgs.)	.0
WP 0096 (4 pgs.)	0	WP 0136 (4 pgs.)	.0
WP 0097 (4 pgs.)	0	WP 0137 (4 pgs.)	.0
WP 0098 (6 pgs.)	0	WP 0138 (4 pgs.)	.0
WP 0099 (2 pgs.)	0	WP 0139 (4 pgs.)	.0
WP 0100 (4 pgs.)	0	WP 0140 (4 pgs.)	.0
(4 pgs.)	0	WP 0141 (4 pgs.)	.0
WP 0101 (4 pgs.)	0	WP 0142 (4 pgs.)	.0
WP 0102 (4 pgs.)	0	WP 0143 (4 pgs.)	.0
WP 0103 (4 pgs.)	0	WP 0144 (4 pgs.)	.0
WP 0104 (4 pgs.)	0	WP 0145 (4 pgs.)	.0
WP 0105 (4 pgs.)	0	WP 0146 (2 pgs.)	.0
		WP 0147 (6 pgs.)	.0
		WP 0148 (16 pgs.)	.0

Page/WP No.	Change No.	Page/WP No.	Change No.
WP 0149 (6 pgs.)	0	WP 0192 (4 pgs.)	0
WP 0150 (4 pgs.)	0	WP 0193 (10 pgs.)	0
WP 0151 (2 pgs.)	0	WP 0194 (8 pgs.)	0
WP 0152 (6 pgs.)	0	WP 0195 (10 pgs.)	0
WP 0153 (2 pgs.)	0	WP 0196 (10 pgs.)	0
WP 0154 (6 pgs.)	0	WP 0197 (12 pgs.)	0
WP 0155 (6 pgs.)	0	WP 0198 (4 pgs.)	0
WP 0156 (6 pgs.)	0	WP 0199 (4 pgs.)	0
WP 0157 (4 pgs.)	0	WP 0200 (4 pgs.)	0
WP 0158 (2 pgs.)	0	WP 0201 (6 pgs.)	0
WP 0159 (2 pgs.)	0	WP 0202 (2 pgs.)	0
WP 0160 (8 pgs.)	0	WP 0203 (2 pgs.)	0
WP 0161 (6 pgs.)	0	Chapter 5 title page	
WP 0162 (8 pgs.)	0	WP 0204 (6 pgs.)	0
WP 0163 (8 pgs.)	0	WP 0205 (2 pgs.)	0
WP 0164 (6 pgs.)	0	WP 0206 (4 pgs.)	0
WP 0165 (6 pgs.)	0	WP 0207 (2 pgs.)	0
WP 0166 (10 pgs.)	0	WP 0208 (6 pgs.)	0
WP 0167 (6 pgs.)	0	WP 0209 (6 pgs.)	0
WP 0168 (6 pgs.)	0	WP 0210 (4 pgs.)	0
WP 0169 (4 pgs.)	0	WP 0211 (6 pgs.)	0
WP 0170 (4 pgs.)	0	WP 0212 (2 pgs.)	0
WP 0171 (6 pgs.)	0	WP 0213 (4 pgs.)	0
WP 0172 (8 pgs.)	0	WP 0214 (6 pgs.)	0
WP 0173 (4 pgs.)	0	WP 0215 (2 pgs.)	0
WP 0174 (4 pgs.)	0	WP 0216 (2 pgs.)	0
WP 0175 (2 pgs.)	0	WP 0217 (4 pgs.)	0
WP 0176 (4 pgs.)	0	WP 0218 (6 pgs.)	0
WP 0177 (6 pgs.)	0	WP 0219 (4 pgs.)	0
WP 0178 (6 pgs.)	0	WP 0220 (2 pgs.)	0
WP 0179 (4 pgs.)	0	WP 0221 (2 pgs.)	0
WP 0180 (4 pgs.)	0	WP 0222 (4 pgs.)	0
WP 0181 (4 pgs.)	0	WP 0223 (4 pgs.)	0
WP 0182 (4 pgs.)	0	WP 0224 (8 pgs.)	0
WP 0183 (4 pgs.)	0	WP 0225 (6 pgs.)	0
WP 0184 (6 pgs.)	0	WP 0226 (4 pgs.)	0
WP 0185 (6 pgs.)	0	WP 0227 (6 pgs.)	0
WP 0186 (4 pgs.)	0	WP 0228 (4 pgs.)	0
WP 0187 (4 pgs.)	0	WP 0229 (6 pgs.)	0
WP 0188 (4 pgs.)	0	WP 0230 (6 pgs.)	0
WP 0189 (2 pgs.)	0	WP 0231 (4 pgs.)	0
WP 0190 (4 pgs.)	0	WP 0232 (4 pgs.)	0
WP 0191 (4 pgs.)	0	WP 0233 (10 pgs.)	0

Page/WP No.	Change No.	Page/WP No.	Change No.
WP 0234 (8 pgs.)	0	WP 0273 (14 pgs.)	.0
WP 0235 (2 pgs.)	0	WP 0274 (4 pgs.)	.0
WP 0236 (2 pgs.)	0	WP 0275 (4 pgs.)	.0
WP 0237 (12 pgs.)	0	WP 0276 (12 pgs.)	.0
WP 0238 (14 pgs.)	0	WP 0277 (10 pgs.)	.0
WP 0239 (4 pgs.)	0	WP 0278 (6 pgs.)	.0
WP 0240 (4 pgs.)	0	WP 0279 (6 pgs.)	.0
WP 0241 (4 pgs.)	0	WP 0280 (10 pgs.)	.0
WP 0242 (4 pgs.)	0	WP 0281 (16 pgs.)	.0
WP 0243 (4 pgs.)	0	WP 0282 (10 pgs.)	.0
WP 0244 (2 pgs.)	0	WP 0283 (12 pgs.)	.0
WP 0245 (2 pgs.)	0	WP 0284 (10 pgs.)	.0
WP 0246 (2 pgs.)	0	WP 0285 (4 pgs.)	.0
WP 0247 (2 pgs.)	0	WP 0286 (6 pgs.)	.0
WP 0248 (4 pgs.)	0	WP 0287 (4 pgs.)	.0
WP 0249 (4 pgs.)	0	WP 0288 (12 pgs.)	.0
WP 0250 (4 pgs.)	0	WP 0289 (50 pgs.)	.0
WP 0251 (4 pgs.)	0	WP 0290 (12 pgs.)	.0
WP 0252 (2 pgs.)	0	WP 0291 (6 pgs.)	.0
WP 0253 (2 pgs.)	0	WP 0292 (6 pgs.)	.0
WP 0254 (2 pgs.)	0	WP 0293 (12 pgs.)	.0
WP 0255 (6 pgs.)	0	WP 0294 (8 pgs.)	.0
WP 0256 (6 pgs.)	0	WP 0295 (10 pgs.)	.0
WP 0257 (6 pgs.)	0	WP 0296 (6 pgs.)	.0
WP 0258 (22 pgs.)	0	WP 0297 (6 pgs.)	.0
WP 0259 (8 pgs.)	0	WP 0298 (4 pgs.)	.0
WP 0260 (6 pgs.)	0	WP 0299 (6 pgs.)	.0
WP 0261 (6 pgs.)	0	WP 0300 (8 pgs.)	.0
WP 0262 (16 pgs.)	0	WP 0301 (4 pgs.)	.0
WP 0263 (10 pgs.)	0	WP 0302 (4 pgs.)	.0
WP 0264 (10 pgs.)	0	WP 0303 (4 pgs.)	.0
WP 0265 (10 pgs.)	0	WP 0304 (2 pgs.)	.0
WP 0266 (16 pgs.)	0	WP 0305 (2 pgs.)	.0
WP 0267 (4 pgs.)	0	WP 0306 (18 pgs.)	.0
WP 0268 (10 pgs.)	0	Chapter 7 title page	
WP 0269 (6 pgs.)	0	WP 0307 (2 pgs.)	.0
Chapter 6 title page		WP 0308 (4 pgs.)	.0
WP 0270 (8 pgs.)	0	WP 0309 (16 pgs.)	.0
WP 0271 (8 pgs.)	0	WP 0310 (6 pgs.)	.0
WP 0272 (14 pgs.)	0	Index (14 pgs.)	.0
		Back Cover (2 pgs.)	.0

TECHNICAL MANUAL  
TM 10-3930-638-24

HEADQUARTERS  
DEPARTMENT OF THE ARMY  
Washington, D.C., 15 July 2008

**TECHNICAL MANUAL**  
**FIELD MAINTENANCE MANUAL**  
**(Includes Unit and Direct Support Maintenance)**

**FOR**

**TRUCK, FORKLIFT, DED,  
PNEUMATIC TIRE, ARTICULATED  
FRAME STEER, 4,000 LB. CAPACITY  
ROUGH TERRAIN, ARMY MODEL MHE 237  
(J.I. CASE MODEL M4K)  
(NSN 3930-01-076-4237)**

**REPORTING ERRORS AND RECOMMENDING IMPROVEMENTS**

You can help improve this publication. If you find any mistakes or if you know of a way to improve the procedures, please let us know. Submit your DA Form 2028 (Recommended Changes to Equipment Technical Publications), through the Internet, on the Army Electronic Product Support (AEPS) website. The Internet address is <https://aeps.ria.army.mil>. The DA Form 2028 is located under the Public Applications section in the AEPS Public Home Page. Fill out the form and click on SUBMIT. Using this form on the AEPS will enable us to respond quicker to your comments and better manage the DA Form 2028 program. You may also mail, fax or E-mail your letter or DA Form 2028 direct to: AMSTA-LC-LMPP/TECH PUBS, TACOM-RI, 1 Rock Island Arsenal, Rock Island, IL 61299-7630. The E-mail address is ROCK-TACOM-TECH-PUBS@conus.army.mil. The fax number is DSN 793-0726 or Commercial (309) 782-0726.

\*Supersedes TM 10-3930-638-24&P dated 1 October 1980, including all changes.

**DISTRIBUTION STATEMENT A** - Approved for public release; distribution is unlimited.

**TABLE OF CONTENTS**

Warning Summary . . . . . a

How to Use This Manual . . . . . xi

**Chapter 1 - INTRODUCTORY INFORMATION, EQUIPMENT  
DESCRIPTION AND DATA, AND THEORY OF OPERATION**

    Introductory Information . . . . . WP 0001

    Equipment Description and Data . . . . . WP 0002

    Theory of Operation . . . . . WP 0003

**Chapter 2 - ORGANIZATIONAL TROUBLESHOOTING PROCEDURES**

    Organizational Troubleshooting Procedures Introduction . . . . . WP 0004

    Organizational Troubleshooting Symptom Index . . . . . WP 0005

    Engine Troubleshooting . . . . . WP 0006

**TABLE OF CONTENTS - CONTINUED**

**WP Sequence No.**

Fuel System Troubleshooting . . . . . WP 0007

Exhaust System Troubleshooting . . . . . WP 0008

Cooling System Troubleshooting . . . . . WP 0009

Battery System Troubleshooting (Model 207) . . . . . WP 0010

Battery System Troubleshooting (Model 4-390) . . . . . WP 0011

Starting System Troubleshooting (Model 207) . . . . . WP 0012

Starting System Troubleshooting (Model 4-390) . . . . . WP 0013

Charging System Troubleshooting (Model 207) . . . . . WP 0014

Charging System Troubleshooting (Model 4-390) . . . . . WP 0015

Horn and Back-Up Alarm System Troubleshooting . . . . . WP 0016

Light Systems Troubleshooting . . . . . WP 0017

Instrument Panel Troubleshooting . . . . . WP 0018

Transmission Troubleshooting . . . . . WP 0019

Axles and Drive Shaft Assemblies Troubleshooting . . . . . WP 0020

Brake System Troubleshooting . . . . . WP 0021

Wheels and Tires Troubleshooting . . . . . WP 0022

Steering System Troubleshooting . . . . . WP 0023

Frame and Towing Attachments Troubleshooting . . . . . WP 0024

Body, Cab, and Hood Troubleshooting . . . . . WP 0025

Hydraulic Lift System Troubleshooting . . . . . WP 0026

Gages Troubleshooting . . . . . WP 0027

**Chapter 3 - DIRECT SUPPORT TROUBLESHOOTING PROCEDURES**

Direct Support Troubleshooting Introduction . . . . . WP 0028

Direct Support Troubleshooting Symptom Index . . . . . WP 0029

Engine Troubleshooting (Model 207) . . . . . WP 0030

Engine Troubleshooting (Model 4-390) . . . . . WP 0031

Fuel System Troubleshooting (Model 207) . . . . . WP 0032

Fuel System Troubleshooting (Model 4-390) . . . . . WP 0033

Alternator Troubleshooting (Model 207) . . . . . WP 0034

Starter and Solenoid Troubleshooting (Model 207) . . . . . WP 0035

Wiring Harness Troubleshooting (Model 207) . . . . . WP 0036

Wiring Harness Troubleshooting (Model 4-390) . . . . . WP 0037

Transmission Troubleshooting . . . . . WP 0038

Axles and Differential Carrier Assemblies Troubleshooting . . . . . WP 0039

Hydraulic Pump Troubleshooting . . . . . WP 0040

Steering Column And Cylinder Troubleshooting . . . . . WP 0041

Chassis Troubleshooting . . . . . WP 0042

Hydraulic Lift System Troubleshooting . . . . . WP 0043



**TABLE OF CONTENTS - CONTINUED**

**WP Sequence No.**

**Chapter 4 - ORGANIZATIONAL MAINTENANCE INSTRUCTIONS**

Service Upon Receipt . . . . .	WP 0044
Preventive Maintenance Checks and Services (PMCS) Introduction . . . . .	WP 0045
Preventive Maintenance Checks and Services (PMCS) Procedures . . . . .	WP 0046
Flywheel Inspection (Model 207). . . . .	WP 0047
Flywheel Inspection (Model 4-390) . . . . .	WP 0048
Draining and Filling Engine Crankcase (Model 207) . . . . .	WP 0049
Draining and Filling Engine Crankcase (Model 4-390) . . . . .	WP 0050
Oil Filter Replacement (Model 207). . . . .	WP 0051
Oil Filter Replacement (Model 4-390) . . . . .	WP 0052
Intake Manifold Replacement (Model 207) . . . . .	WP 0053
Intake Manifold Replacement (Model 4-390) . . . . .	WP 0054
Exhaust Manifold Maintenance (Model 207) . . . . .	WP 0055
Exhaust Manifold Replacement (Model 4-390) . . . . .	WP 0056
Fuel Injection Pump Testing (Model 207) . . . . .	WP 0057
Fuel Injection Pump Testing (Model 4-390) . . . . .	WP 0058
Electric Fuel Pump and Lines Maintenance (Model 207) . . . . .	WP 0059
Fuel Pump and Lines Maintenance (Model 4-390) . . . . .	WP 0060
Air Cleaner Maintenance (Model 207). . . . .	WP 0061
Air Cleaner Maintenance (Model 4-390) . . . . .	WP 0062
Fuel Tank Servicing (Model 207) . . . . .	WP 0063
Fuel Tank Servicing (Model 4-390) . . . . .	WP 0064
Fuel Tank Lines and Fittings Replacement (Model 207) . . . . .	WP 0065
Fuel Tank Lines and Fittings Replacement (Model 4-390) . . . . .	WP 0066
In-line Fuel Filter Replacement (Model 207) . . . . .	WP 0067
In-line Fuel Filter Replacement (Model 4-390) . . . . .	WP 0068
Fuel Filter Maintenance (Model 207). . . . .	WP 0069
Fuel Tank Strainer Replacement (Model 207) . . . . .	WP 0070
Fuel Tank Strainer Replacement (Model 4-390) . . . . .	WP 0071
Fuel Filter Servicing and Replacement (model 4-390) . . . . .	WP 0072
Quick Start Kit Replacement . . . . .	WP 0073
Accelerator and Throttle Control Maintenance (Model 207) . . . . .	WP 0074
Accelerator and Throttle Control Maintenance (Model 4-390) . . . . .	WP 0075
Spark Arresting Muffler and Exhaust Pipe Maintenance (Model 207). . . . .	WP 0076
Spark Arresting Muffler and Exhaust Pipe Maintenance (Model 4-390) . . . . .	WP 0077
Radiator Servicing (Model 207). . . . .	WP 0078
Radiator Servicing (Model 4-390) . . . . .	WP 0079
Radiator Hoses Replacement (Model 207) . . . . .	WP 0080
Radiator Hoses Replacement (Model 4-390) . . . . .	WP 0081

**TABLE OF CONTENTS - CONTINUED**

**WP Sequence No.**

Radiator and Shroud Maintenance (Model 207) . . . . . WP 0082

Radiator and Shroud Maintenance (Model 4-390) . . . . . WP 0083

Thermostat and Housing Maintenance (Model 207) . . . . . WP 0084

Thermostat and Housing Maintenance (Model 4-390) . . . . . WP 0085

Water Pump Replacement (Model 207) . . . . . WP 0086

Water Pump Replacement (Model 4-390) . . . . . WP 0087

Fan and Fan Belt Maintenance (Model 207) . . . . . WP 0088

Fan and Fan Belt Replacement (Model 4-390) . . . . . WP 0089

Fan Belt Tensioner Replacement (Model 4-390) . . . . . WP 0090

Fan Pulley Bracket Maintenance (Model 4-390) . . . . . WP 0091

Coolant Inlet Manifold Replacement (Model 4-390) . . . . . WP 0092

Alternator Maintenance (Model 207) . . . . . WP 0093

Alternator Maintenance (Model 4-390) . . . . . WP 0094

Starter Maintenance (Model 207) . . . . . WP 0095

Starter Replacement (Model 4-390) . . . . . WP 0096

Starter Relay and 25 AMP Circuit Breaker Replacement (Model 207) . . . . . WP 0097

Relay Panel Cover and Capacitor Replacement (Model 4-390) . . . . . WP 0098

Starter Lock-Out Relay Replacement (Model 4-390) . . . . . WP 0099

25 AMP Breaker Replacement (Model 4-390) . . . . . WP 0100

Terminal Block Replacement (Model 4-390) . . . . . WP 0101

Starter Relay Replacement (Model 4-390) . . . . . WP 0102

Resistor Replacement (Model 4-390) . . . . . WP 0103

Floodlight Switches and Circuit Breakers Replacement . . . . . WP 0104

Start Switch and Vehicle Lights Switch Replacement . . . . . WP 0105

Ignition Switch and Circuit Breaker Replacement . . . . . WP 0106

Lock-Out Relay Replacement . . . . . WP 0107

Warning Lights and Diodes Maintenance . . . . . WP 0108

Slave Receptacle Replacement . . . . . WP 0109

Hourmeter Replacement . . . . . WP 0110

Floodlights Maintenance (Model 207) . . . . . WP 0111

Floodlights Maintenance (Model 4-390) . . . . . WP 0112

Front Blackout Light Maintenance . . . . . WP 0113

Rear Blackout Lights Maintenance . . . . . WP 0114

Stop and Taillights Maintenance (Model 207) . . . . . WP 0115

Stop and Taillights Maintenance (Model 4-390) . . . . . WP 0116

Fuel Gage Sending Unit Replacement . . . . . WP 0117

Neutral Start Switch and Back-Up Alarm Switch  
Replacement (Model 207) . . . . . WP 0118

Neutral Start Switch and Back-Up Alarm Switch

**TABLE OF CONTENTS - CONTINUED**

**WP Sequence No.**

Replacement (Model 4-390) . . . . . WP 0119

Engine Temperature Switch Maintenance (Model 207) . . . . . WP 0120

Transmission Temperature Switch Replacement (Model 207) . . . . . WP 0121

Engine and Transmission Temperature Switches  
Maintenance (Model 4-390). . . . . WP 0122

Engine Oil Pressure Switch and Sending Unit  
Maintenance (Model 207) . . . . . WP 0123

Engine Oil Pressure Switch and Sending Unit  
Maintenance (Model 4-390). . . . . WP 0124

Hydraulic Filter Restriction Switch Replacement. . . . . WP 0125

Stop Light Switch Replacement. . . . . WP 0126

Horn Replacement (Model 207) . . . . . WP 0127

Horn Replacement (Model 4-390) . . . . . WP 0128

Horn Switch Maintenance . . . . . WP 0129

Back-Up Alarm Replacement (Model 207) . . . . . WP 0130

Back-Up Alarm Replacement (Model 4-390). . . . . WP 0131

Battery Cover Maintenance . . . . . WP 0132

Batteries and Battery Cables Replacement (Model 207) . . . . . WP 0133

Batteries and Battery Cables Replacement (Model 4-390) . . . . . WP 0134

Front Wiring Harness Maintenance (Model 207). . . . . WP 0135

Front Wiring Harness Maintenance (Model 4-390) . . . . . WP 0136

Rear Wiring Harness Maintenance (Model 207) . . . . . WP 0137

Rear Wiring Harness Maintenance (Model 4-390) . . . . . WP 0138

Adapter Wiring Harness Maintenance (Model 4-390) . . . . . WP 0139

Relay Panel Wiring Harness Maintenance (Model 4-390). . . . . WP 0140

Fuel Injection Wiring Harness Maintenance (Model 4-390). . . . . WP 0141

Cable Wiring Harness Maintenance (Model 4-390). . . . . WP 0142

Draining and Filling Transmission . . . . . WP 0143

Transmission Screen Replacement. . . . . WP 0144

Transmission Air Breather Replacement. . . . . WP 0145

Transmission Oil Filter Replacement. . . . . WP 0146

Transmission Inspection . . . . . WP 0147

Transmission Linkage Controls Maintenance . . . . . WP 0148

Axle Disconnect Lever Replacement. . . . . WP 0149

Transmission Dipstick Tube Replacement . . . . . WP 0150

Transmission Control Valve Inspection . . . . . WP 0151

Transmission Hoses, Lines, and Fittings Replacement. . . . . WP 0152

Transmission Oil Cooler Replacement . . . . . WP 0153

Front Drive Shaft and Support Bearing Maintenance . . . . . WP 0154

**TABLE OF CONTENTS - CONTINUED**

**WP Sequence No.**

Center Drive Shaft Maintenance . . . . . WP 0155

Rear Drive Shaft Maintenance . . . . . WP 0156

Front and Rear Axles Maintenance . . . . . WP 0157

Front Axle Air Breather Replacement . . . . . WP 0158

Rear Axle Air Breather Replacement . . . . . WP 0159

Front and Rear Axle Shafts and Bearings Maintenance . . . . . WP 0160

Parking Brake Linkage Maintenance . . . . . WP 0161

Parking Brake Maintenance . . . . . WP 0162

Service Brake Maintenance . . . . . WP 0163

Brake Hoses, Lines, and Fittings Replacement . . . . . WP 0164

Brake Master Cylinder Replacement . . . . . WP 0165

Brake Power Assist Unit Maintenance . . . . . WP 0166

Declutch Valve Maintenance . . . . . WP 0167

Brake Pedal and Declutch Pedal Maintenance . . . . . WP 0168

Wheels and Tires Maintenance . . . . . WP 0169

Hydraulic Pump Replacement . . . . . WP 0170

Steering Hoses, Lines, and Fittings Maintenance  
(Steering Gear to Steering Cylinder) . . . . . WP 0171

Steering Hoses, Lines, and Fittings Maintenance  
(Hydraulic Pump To Steering Gear) . . . . . WP 0172

Steering Cylinder Replacement . . . . . WP 0173

Rollover Protective Structure Replacement . . . . . WP 0174

Chassis Stop Bumper Replacement . . . . . WP 0175

Tow Bar, Tow Chains, and Pintle Hook Replacement . . . . . WP 0176

Grille Maintenance . . . . . WP 0177

Fenders Replacement . . . . . WP 0178

Side Panels Maintenance . . . . . WP 0179

Top Hood Replacement (Model 207) . . . . . WP 0180

Top Hood Replacement (Model 4-390) . . . . . WP 0181

Hood Panels and Hood Support Plates Replacement (Model 207) . . . . . WP 0182

Hood Panels and Hood Support Plates Replacement (Model 4-390) . . . . . WP 0183

Front Cover Panel Replacement . . . . . WP 0184

Operator's Seat Maintenance (Model 207) . . . . . WP 0185

Operator's Seat Maintenance (Model 4-390) . . . . . WP 0186

Noise Baffle Mat Replacement . . . . . WP 0187

Chassis Floor Plate and Guard Replacement . . . . . WP 0188

Stowage Box Replacement (Model 4-390) . . . . . WP 0189

Hydraulic Lift System Operational Test . . . . . WP 0190

Hydraulic Control Levers and Linkages Maintenance . . . . . WP 0191

Lifting Forks Replacement . . . . . WP 0192

**TABLE OF CONTENTS - CONTINUED**

**WP Sequence No.**

Lift Chains and Pulleys Maintenance . . . . . WP 0193

Sideshift Chains and Pulleys Maintenance . . . . . WP 0194

Hydraulic Hoses, Lines, and Fittings Maintenance  
(Hydraulic Oil Filter to Control Valve to Mast) . . . . . WP 0195

Hydraulic Hoses, Lines, and Fittings Replacement  
(Mast) Serial No. 9150572 and Below . . . . . WP 0196

Hydraulic Hoses, Lines, and Fittings Replacement  
(Mast) Serial No. 9150573 and Above . . . . . WP 0197

Draining and Filling Hydraulic Reservoir . . . . . WP 0198

Hydraulic Oil Filter and Filter Head Replacement . . . . . WP 0199

Hydraulic Oil Reservoir Strainer Replacement . . . . . WP 0200

Hydraulic Oil Reservoir and Air Breather Replacement . . . . . WP 0201

Gage Bulb Replacement . . . . . WP 0202

Gage Replacement . . . . . WP 0203

**Chapter 5 - DIRECT SUPPORT MAINTENANCE INSTRUCTIONS**

Locating Top Dead Center (Model 207) . . . . . WP 0204

Locating Top Dead Center (Model 4-390) . . . . . WP 0205

Valve Tappet Clearance Adjustment (Model 207) . . . . . WP 0206

Valve Tappet Clearance Adjustment (Model 4-390) . . . . . WP 0207

Fuel Injection Pump Adjustments (Model 207) . . . . . WP 0208

Engine Mount Replacement (Model 207) . . . . . WP 0209

Engine Mount Replacement (Model 4-390) . . . . . WP 0210

Power Pack Replacement (Model 207) . . . . . WP 0211

Power Pack Replacement (Model 4-390) . . . . . WP 0212

Separation of Engine and Transmission (Model 207) . . . . . WP 0213

Separation of Engine and Transmission (Model 4-390) . . . . . WP 0214

Cylinder Block Inspection (Model 207) . . . . . WP 0215

Cylinder Block Inspection (Model 4-390) . . . . . WP 0216

Tachometer Drive Replacement (Model 207) . . . . . WP 0217

Cylinder Head Replacement (Model 207) . . . . . WP 0218

Cylinder Head Replacement (Model 4-390) . . . . . WP 0219

Flywheel Housing Inspection (Model 207) . . . . . WP 0220

Flywheel Housing Inspection (Model 4-390) . . . . . WP 0221

Rocker Arm Cover Maintenance (Model 207) . . . . . WP 0222

Rocker Arm Cover Replacement (Model 4-390) . . . . . WP 0223

Rocker Arm Assembly Maintenance (Model 207) . . . . . WP 0224

Rocker Arm Assembly Maintenance (Model 4-390) . . . . . WP 0225

Engine Oil Pan Maintenance (Model 207) . . . . . WP 0226

Engine Oil Pan Maintenance (Model 4-390) . . . . . WP 0227

**TABLE OF CONTENTS - CONTINUED**

**WP Sequence No.**

Engine Oil Cooler Maintenance (Model 4-390) . . . . .	WP 0228
Fuel Injection Lines and Fittings Maintenance (Model 207) . . . . .	WP 0229
Fuel Injection Lines and Fittings Maintenance (Model 4-390) . . . . .	WP 0230
Fuel Injector Replacement (Model 207) . . . . .	WP 0231
Fuel Injector Maintenance (Model 4-390) . . . . .	WP 0232
Fuel Injection Pump Replacement (Model 207) . . . . .	WP 0233
Fuel Injection Pump Replacement (Model 4-390) . . . . .	WP 0234
Radiator and Shroud Repair (Model 207) . . . . .	WP 0235
Radiator and Shroud Repair (Model 4-390) . . . . .	WP 0236
Alternator Repair (Model 207) . . . . .	WP 0237
Starter and Solenoid Repair (Model 207) . . . . .	WP 0238
Instrument Panel Replacement . . . . .	WP 0239
Front Wiring Harness Replacement (Model 207) . . . . .	WP 0240
Front Wiring Harness Replacement (Model 4-390) . . . . .	WP 0241
Rear Wiring Harness Replacement (Model 207) . . . . .	WP 0242
Rear Wiring Harness Replacement (Model 4-390) . . . . .	WP 0243
Adapter Wiring Harness Replacement (Model 4-390) . . . . .	WP 0244
Relay Panel Wiring Harness Replacement (Model 4-390) . . . . .	WP 0245
Fuel Injection Wiring Harness Replacement (Model 4-390) . . . . .	WP 0246
Cable Wiring Harness Replacement (Model 4-390) . . . . .	WP 0247
Transmission Pressure Checks . . . . .	WP 0248
Transmission Mounts Replacement . . . . .	WP 0249
Transmission Control Valve and Modulation Valve Replacement . . . . .	WP 0250
Transmission Charging Pump Replacement . . . . .	WP 0251
Transmission Oil Cooler Repair . . . . .	WP 0252
Front Axle Replacement . . . . .	WP 0253
Rear Axle Replacement . . . . .	WP 0254
Front Axle Differential Carrier Replacement . . . . .	WP 0255
Rear Axle Differential Carrier Replacement . . . . .	WP 0256
Steering Wheel and Steering Column Maintenance . . . . .	WP 0257
Steering Gear Maintenance . . . . .	WP 0258
Hydraulic Pump Repair . . . . .	WP 0259
Steering Cylinder Repair . . . . .	WP 0260
Separation of Front and Rear Chassis . . . . .	WP 0261
Hydraulic Control Valve Maintenance . . . . .	WP 0262
Tilt Cylinders Maintenance . . . . .	WP 0263
Sideshift Cylinder Maintenance . . . . .	WP 0264
Rotation Cylinder Maintenance . . . . .	WP 0265
Lift Cylinder Maintenance . . . . .	WP 0266

**TABLE OF CONTENTS - CONTINUED**

**WP Sequence No.**

Carriage Maintenance . . . . .	WP 0267
Side Shifter Frame and Rotation Bearing Maintenance . . . . .	WP 0268
Inner and Outer Mast Maintenance . . . . .	WP 0269
<b>Chapter 6 - GENERAL SUPPORT MAINTENANCE INSTRUCTIONS</b>	
Cylinder Block Repair (Model 207) . . . . .	WP 0270
Cylinder Block Repair (Model 4-390). . . . .	WP 0271
Cylinder Head and Valves Repair (Model 207) . . . . .	WP 0272
Cylinder Head and Valves Repair (Model 4-390) . . . . .	WP 0273
Crankshaft Oil Seal Retainer Replacement (Model 207). . . . .	WP 0274
Crankshaft Oil Seal Retainer Replacement (Model 4-390) . . . . .	WP 0275
Crankshaft and Main Bearings Replacement (Model 207) . . . . .	WP 0276
Crankshaft and Main Bearings Replacement (Model 4-390). . . . .	WP 0277
Flywheel and Flywheel Housing Replacement (Model 207) . . . . .	WP 0278
Flywheel and Flywheel Housing Replacement (Model 4-390) . . . . .	WP 0279
Pistons and Connecting Rods Maintenance (Model 207) . . . . .	WP 0280
Pistons and Connecting Rods Maintenance (Model 4-390) . . . . .	WP 0281
Camshaft and Bearings Maintenance (Model 207) . . . . .	WP 0282
Camshaft and Bearings Maintenance (Model 4-390) . . . . .	WP 0283
Timing Gear Cover Replacement (Model 207) . . . . .	WP 0284
Timing Gear Cover Replacement (Model 4-390). . . . .	WP 0285
Oil Pump Maintenance (Model 207) . . . . .	WP 0286
Oil Pump Replacement (Model 4-390) . . . . .	WP 0287
Fuel Injector Repair (Model 207). . . . .	WP 0288
Fuel Injection Pump Repair (Model 207) . . . . .	WP 0289
Torque Converter Repair. . . . .	WP 0290
Torque Converter Housing Repair. . . . .	WP 0291
Transmission Rear Cover Replacement . . . . .	WP 0292
Transmission Gears and Clutches Repair. . . . .	WP 0293
Transmission Housing Repair . . . . .	WP 0294
Reverse and Second Clutch Repair . . . . .	WP 0295
Low Clutch Repair . . . . .	WP 0296
Third Clutch Repair . . . . .	WP 0297
Forward Clutch Repair. . . . .	WP 0298
Control Valve Repair . . . . .	WP 0299
Modulation Valve Repair . . . . .	WP 0300
Differential Carrier Repair . . . . .	WP 0301
Differential Case and Gears Repair. . . . .	WP 0302
Rear Axle Trunnion Replacement . . . . .	WP 0303
Torque Limits. . . . .	WP 0304

**TABLE OF CONTENTS - CONTINUED**

**WP Sequence No.**

Illustrated List Of Manufactured Items . . . . . WP 0305

Electrical and Hydraulic Diagrams . . . . . WP 0306

**Chapter 7 SUPPORTING INFORMATION - References . . . . . WP 0307**

Maintenance Allocation Chart (MAC) Introduction . . . . . WP 0308

Maintenance Allocation Chart (MAC) . . . . . WP 0309

Expendable and Durable Items List . . . . . WP 0310

Index . . . . . Index 1



---

# HOW TO USE THIS MANUAL

## NOTE

If at any time you are unsure how to use this manual or you cannot locate the information you need, notify your supervisor.

## INTRODUCTION

1. This manual is designed to help you perform troubleshooting and maintenance on the MHE 237 Forklift Truck.
2. This manual is written in work package format:
  - a. Chapters divide the manual into major categories of information.
  - b. Each chapter is divided into work packages, which are identified by a 4-digit number (e.g., 0001, 0002) located in the upper right-hand corner of each page. The work package page number (e.g., 0001-1, 0001-2) is located centered at the bottom of each page.
  - c. In this manual are the terms “original vehicle” and “replacement vehicle”. The term “replacement vehicle” refers to a vehicle that has either the 4-390 engine installed, the new seat installed, or both the 4-390 engine and the new seat installed. The term “original vehicle” refers to a vehicle that has neither the new seat nor the 4-390 engine installed. The new seat is easily identified by having retractable seat belts. Besides looking at the engine date plate, a vehicle having the 4-390 engine installed is easily identified by looking at the exhaust - on vehicles with the 4-390 engine installed the exhaust will be on the left side of the vehicle.
3. Read through this manual to become familiar with its organization and contents before attempting to operate or maintain the equipment.

## CONTENTS OF THIS MANUAL

1. A *Warning Summary* is located at the beginning of this manual. Become familiar with these warnings before operating or performing troubleshooting or maintenance on the vehicle.
2. A *Table of Contents*, located in the front of the manual, lists all chapters and work packages in this manual. The *Table of Contents* also provides *Reporting Errors and Recommending Improvements* information and DA Form 2028 addresses, for the submittal of corrections to this manual.
3. Chapter 1, *Introductory Information, Equipment Description and Data, and Theory of Operation*, provides general information on the manual and the equipment.
4. Chapter 2 covers *Organizational Troubleshooting Procedures*. It contains a *Troubleshooting Symptom Index*. If the vehicle malfunctions, this index should always be consulted to locate the appropriate troubleshooting procedure.
5. Chapter 3 covers *Direct Support Troubleshooting Procedures*. It also contains a *Troubleshooting Symptom Index*. If the vehicle malfunctions, this index should always be consulted to locate the appropriate troubleshooting procedure.
6. Chapter 4 covers *Organizational Maintenance Instructions*. Areas covered are *Preventive Maintenance Checks and Services (PMCS)* including lubrication instructions and Organizational-level maintenance tasks.
7. Chapter 5 covers *Direct Support Maintenance Instructions*. Areas covered are *Preventive Maintenance Checks and Services (PMCS)* including lubrication instructions and DS-level maintenance tasks.
8. Chapter 6 covers *General Support Maintenance Instructions*. Covered are GS-level maintenance tasks.
9. Chapter 7 includes *Supporting Information: References, Maintenance Allocation Chart (MAC), and Expendable and Durable Items List*.

## FEATURES OF THIS MANUAL

1. WARNINGS, CAUTIONS, NOTES, subject headings, and other important information are titled in **BOLD** print as a visual aid.

### WARNING

A WARNING indicates a hazard which may result in injury or death to personnel.

### CAUTION

A CAUTION is a reminder of safety practices or directs attention to usage practices that may result in damage to equipment.

### NOTE

A NOTE is a statement containing information that will make the procedures easier to perform.

2. Statements and words of particular interest may be printed in underlined or CAPITAL letters to create emphasis.
3. Within a procedural step, reference may be made to another work package in this manual or to another manual. These references indicate where you should look for more complete information.
4. Illustrations are placed after, and as close to, the procedural steps to which they apply. Callouts placed on the art are text or numbers.
5. Numbers located in the lower right corner of art (e.g., 444-0156; 444-0157) are art control numbers and are used for tracking purposes only.

**CHAPTER 1**  
**INTRODUCTORY INFORMATION, EQUIPMENT**  
**DESCRIPTION AND DATA, AND THEORY OF OPERATION**



---

# INTRODUCTORY INFORMATION, EQUIPMENT DESCRIPTION AND DATA, AND THEORY OF OPERATION

---

## INTRODUCTORY INFORMATION

---

### SCOPE

1. *Type of Manual:* Organizational, Direct Support, and General Support Maintenance Manual.
2. *Model Number and Equipment Name:* MHE 237 Rough Terrain 4,000-lb Capacity, Articulated Frame Steer, Pneumatic Tire, Diesel Engine Driven Forklift Truck.
3. *Purpose of Equipment:* Handle, transport, and stack materiel on various types of terrain. The MHE 237 Forklift Truck has a capacity of 4,000-lb at 24-in. load center and can lift the load to a maximum height of 100 in.

### MAINTENANCE FORMS, RECORDS AND REPORTS

Department of the Army forms and procedures used for equipment maintenance will be those prescribed by DA PAM 738-750, *The Army Maintenance Management System (TAMMS) User Manual*.

### DESTRUCTION OF ARMY MATERIEL TO PREVENT ENEMY USE

Refer to TM 750-244-6.

### ADMINISTRATIVE STORAGE

Refer to TM 740-93-1.

### REPORTING OF ERRORS

You can help improve this publication. If you find any mistakes or if you know of a way to improve the procedures, please let us know. Submit your DA Form 2028 (Recommended Changes to Equipment Technical Publications), through the Internet, on the Army Electronic Product Support (AEPS) website. The Internet address is: <https://aeeps.ria.army.mil>. The DA Form 2028 is located under the Public Applications section in the AEPS Public Home Page. Fill out the form and click on SUBMIT. Using this form on the AEPS will enable us to respond quicker to your comments and better manage the DA Form 2028 program. You may also mail, fax or E-mail your letter or DA Form 2028 direct to: AMSTA-LC-LMPP/TECH PUBS, TACOM-RI, 1 Rock Island Arsenal, Rock Island, IL 61299-7630. The E-mail address is ROCK-TACOM-TECH-PUBS@conus.army.mil. The fax number is DSN 793-0726 or Commercial (309) 782-0726.

### WARRANTY INFORMATION

Refer to TB 10-2300-295-15-18 for warranty information.

### ORIENTATION

The lifting forks are mounted on the front of the vehicle and the engine faces the rear. Controls for operating the lifting forks (tilting, rotating, lowering, side shifting of the lifting forks) are located to the right when you are sitting in the operator's seat.

### COMMON TOOLS AND EQUIPMENT

For authorized common tools and equipment refer to the Modified Table of Organization and Equipment (MTOE) applicable to your unit.

### REPAIR PARTS

Repair parts are listed/illustrated in TM 10-3930-638-24P.

### LIST OF ABBREVIATIONS

Refer to the Glossary at the end of this manual (before the Index) for a list of abbreviations used in this publication.

---

## **DIFFERENT VEHICLE CONFIGURATIONS**

To support sustainment of the model MHE 237 Forklift Truck, some components have been replaced with a different design. The most obvious of these replacements are the driver's seat and the engine. The vehicle may have any combination of these configurations, or none. The most obvious indication of which seat is installed is that the original seat did not have retractable seat belts. The replacement seat does have retractable seat belts. The most obvious indication of which engine is installed is that on vehicles with the original engine installed, the engine exhaust pipe is on the top RIGHT side of the vehicle. Vehicles that have the replacement engine installed have the engine exhaust pipe on the top LEFT side of the vehicle. The replacement engine required minor modification to the chassis and replacement of other supporting hardware/components. To replace the engine in a vehicle that has the original engine installed, you must order the NSN for the Engine Modification Kit. To replace the engine in a vehicle that has the replacement engine already installed, you must order the NSN for just the engine. For the engine, components will be identified by the engine model number. The original engine is model 207. The replacement engine is 4-390. Various other components that have been replaced will be identified as "original" or "replacement" in this manual.

## **END OF WORK PACKAGE**

---

# INTRODUCTORY INFORMATION, EQUIPMENT DESCRIPTION AND DATA, AND THEORY OF OPERATION

## THEORY OF OPERATION

---

### FORKLIFT TRUCK

1. *Engine.* The diesel engine is an internal combustion power unit in which the heat of diesel fuel is converted into work in the engine cylinders. The engine relies on the heat of compressed air to ignite the fuel. Fuel flow and engine speed are controlled by the fuel injection pump governor and fuel injectors.
2. *Fuel System.* In an original vehicle, fuel is drawn from fuel tank by electric fuel pump through an in-line fuel filter. Fuel is filtered again through a primary and final fuel filter and passes to fuel injection pump. Fuel, under pressure, is routed to four fuel injectors and injected into engine cylinders.  
  
In a replacement vehicle, fuel from the fuel tank passes through an in-line fuel filter to the mechanical fuel pump on the right side of the engine. Fuel then passes through another fuel filter to the fuel injection pump. Fuel, under pressure, is routed to four fuel injectors and injected into engine cylinders.
3. *Exhaust System.* Engine combustion by-products are channeled through the exhaust manifold, muffler, and exhaust pipe. The muffler aids in quieting engine noise.
4. *Cooling System.* Provides cooling water to engine. Water is circulated through engine by water pump which is belt driven by crankshaft pulley. Transmission oil cooler is located in front of radiator. Radiator is equipped with coolant recovery system.
5. *Electrical System.* 24V system with negative ground. Power provided by two batteries. Alternator is mounted on, and driven by, engine. Ignition switch controls application of power to main light switch and starter motor.
6. *Transmission and Drive Shafts.* Three speeds in both forward and reverse, has declutch feature which permits neutralizing transmission, equipped with axle disconnect. Three drive shafts used to transmit power to front and rear axles.
7. *Axles and Wheels.* Single reduction type axles; pneumatic tires. Front axle is rigidly mounted; rear axle is trunnion mounted.
8. *Brakes.* Service brakes consist of drum and shoe hydraulic wheel brakes on front and rear wheels for stopping the truck. A hydraulic brake valve is mounted under the front chassis and provides power assist for service brakes. Parking brake is mounted on output shaft of transmission.
9. *Steering System.* Consists of hydraulic steering gear, steering wheel, and two steering cylinders one mounted on each side of truck. Power assist provided by hydraulic pump mounted on, and driven by, transmission.
10. *Body and Towing Attachments.* Chassis is comprised of front chassis and rear chassis connected by pivot pins. This enables steering to be accomplished by pivoting of front and rear chassis on pins by means of a steering cylinder mounted on each side of chassis to front and rear chassis. Pintle hook and tow bar and chains, all located at rear, enable towing to be accomplished.
11. *Hydraulic Lift System.* Hydraulic power supplied by hydraulic pump mounted on, and driven by, transmission. Hydraulic oil routed through hoses to control valve which controls flow of oil to lift cylinder, and to and from tilt cylinders, side shift cylinder, and rotation cylinder.

### ENGINE

The engine is a four cylinder, in-line, four-stroke-cycle, valve-in-head diesel engine. Air enters the intake manifold through a dry-type air cleaner. An ether injection arrangement is connected to the intake manifold for quick starting of the engine during cold weather.

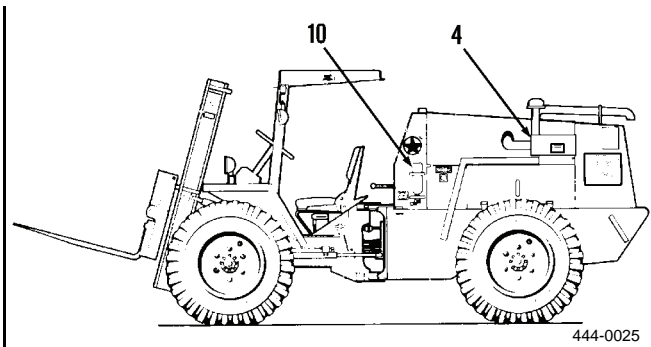
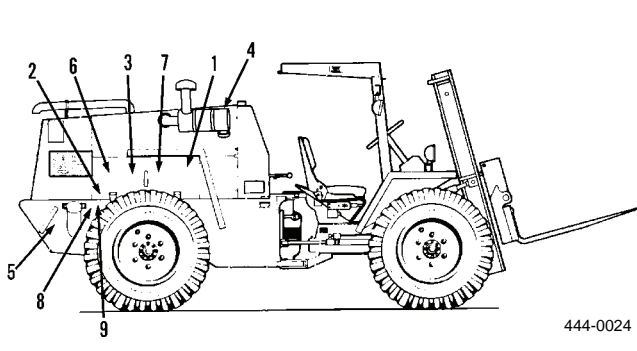
**FUEL SYSTEM**

1. **FUEL INJECTORS.** Four used; closed end, differential pressure, hydraulically operated, hole type injector.
2. **ELECTRIC FUEL PUMP (Original vehicle).** Operates on 24V; pumps fuel from fuel tank through in-line fuel filter, and to fuel injection pump through primary and final fuel filters.
3. **MECHANICAL FUEL PUMP (Replacement vehicle).** Fuel passes from fuel tank through in-line fuel filter to mechanical fuel pump. Fuel is then pumped through another filter to fuel injection pump.

**WARNING**

If NBC exposure is suspected, all air filter media should be handled by personnel wearing protective equipment. Consult your unit NBC Officer or NBC NCO for appropriate handling or disposal procedures.

4. **AIR CLEANER.** Dry type air cleaner. Filters air before air is applied to intake manifold.
5. **FUEL TANK.** 27 gal. capacity; part of rear chassis.
6. **FUEL INJECTION PUMP.** Fuel from fuel filters is routed to fuel injection pump where fuel is metered accurately and applied to each cylinder at high pressure through fuel injector nozzles at precisely timed intervals. Fuel metering is controlled by the throttle shaft lever, which is connected by cable to operator's accelerator pedal. Speed regulating governor mounted at top of fuel injection pump. Equipped with electrical solenoid for positive fuel shut-off.
7. **FUEL FILTER(S).** Fuel filters remove fuel oil impurities which may damage fuel injection pump and/or fuel injectors.
8. **FUEL STRAINER.** Located in fuel tank. Blocks passage of sediment to fuel system.
9. **IN-LINE FUEL FILTER.** Provides additional fuel filtering capacity of fuel passing from fuel tank to other components of fuel system.
10. **QUICK START SYSTEM.** Injects volatile starting fuel into engine to provide easier starting in cold weather. Connected by tube to intake manifold.

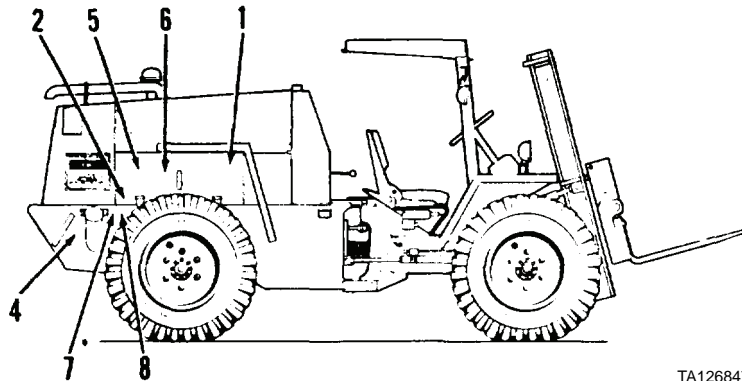

**EXHAUST SYSTEM**

TA126847

1. MUFFLER. Muffles engine noise. Mounted on top of engine.
2. EXHAUST PIPE. Channels engine exhaust smoke/combustion by-products from engine to rear of truck.

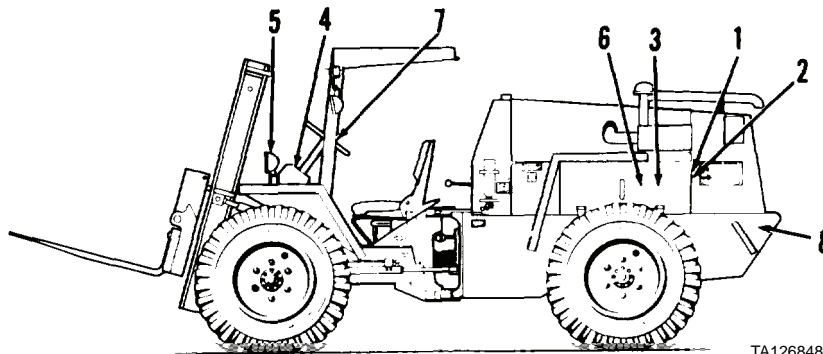
**COOLING SYSTEM**

TA126848

1. RADIATOR. Mounted at rear of truck; cools engine coolant. Includes a coolant recovery system.
2. THERMOSTAT AND HOUSING. Mounted on front of engine at rear of truck. Thermostat opens at 180°F (82°C).
3. HOSES. Two hoses route coolant to and from engine and radiator.
4. WATER PUMP. Mounted to engine and belt driven. Circulates coolant between engine and radiator.
5. FAN. Mounted to engine and belt driven. Rotates to force air through radiator to reduce temperature of coolant.
6. DRIVE BELT. Driven by pulley at end of engine crankshaft. Transmits rotation to pulleys of alternator, water pump, and fan.

## ELECTRICAL SYSTEM

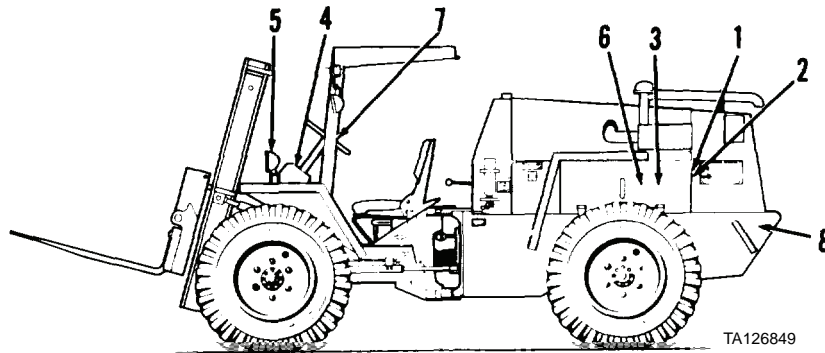

TA126849

1. ALTERNATOR. 40 ampere; charges batteries and supplies current for additional electrical power.
2. DRIVE BELT. Drives alternator through engine crankshaft pulley.
3. STARTER MOTOR. Electric motor with an over-running clutch. Solenoid is mounted on starter with an enclosed shifting mechanism.
4. INSTRUMENT PANEL. Refer to *Instrument Panel Gages and Indicators* and *Instrument Panel Switches and Gage Lights* in this work package for a description of gages, lights, and switches mounted on instrument panel.
5. LIGHTS. Mounted at rear of truck are two floodlights, two stop and taillights, and two blackout stop and taillights. Mounted at front of truck are four floodlights and one blackout light. Operation of all lights is controlled by VEHICLE LIGHTS switch mounted on instrument panel. Front and rear floodlights also have individual switches.
6. SENDING UNITS. Includes oil pressure sending unit mounted on side of engine and fuel level sending unit mounted in fuel tank.
7. HORN AND SWITCH. Electric horn operates from 24V and is mounted at front of truck; horn switch located in steering wheel horn button applies 24V to horn when depressed.
8. BATTERIES. Two 12V batteries connected in series giving a 24V electrical power supply.

### Instrument Panel Gages and Indicators

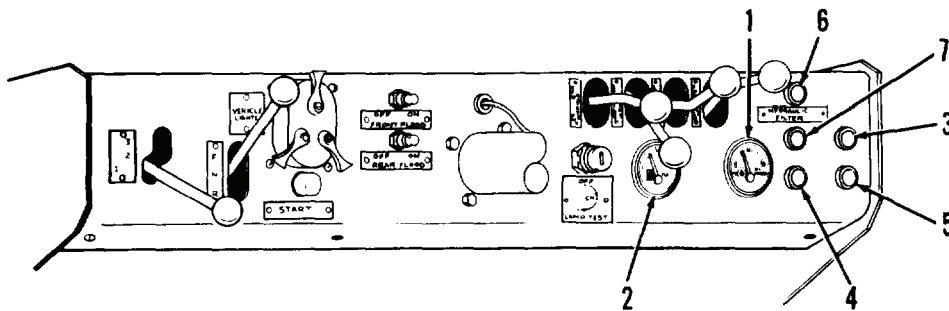

TA126850

1. OIL PRESSURE GAGE. Indicates engine oil pressure and is electrically connected to engine oil pressure sender located on right side of engine.
2. FUEL GAGE. Indicates quantity of fuel in fuel tank. Electrically connected to fuel level sender located on top of fuel tank.
3. ENGINE OIL PRESSURE INDICATOR. Illuminates indicating low oil pressure. Electrically connected to engine oil pressure switch located on right side of engine near fuel filters. Indicator illuminates when switch closes at decreasing pressure of 8 +/- 2.5 PSI (55 +/- 17 kPa).

**ELECTRICAL SYSTEM - CONTINUED****Instrument Panel Gages and Indicators - Continued**

4. ENGINE WATER TEMPERATURE INDICATOR. Illuminates indicating engine is overheated. Electrically connected to engine temperature switch located in cylinder head. Indicator illuminates when switch closes at 205°F (96°C).
5. ALTERNATOR INDICATOR. Illuminates indicating battery is not recharging. Connected to terminal 1 of alternator.
6. HYDRAULIC FILTER INDICATOR. Illuminates indicating hydraulic filter is clogged and requires replacement. Electrically connected to hydraulic filter switch located in filter head. Indicator illuminates when switch closes at 20+/-3 PSI (138 +/- 21 kPa).
7. TRANSMISSION TEMPERATURE INDICATOR. Illuminates indicating transmission is overheated. Electrically connected to transmission temperature switch located in right side of transmission. Indicator illuminates when switch closes at 265°F (129°C).

**NOTE**

Hydraulic filter, transmission temperature, and engine temperature indicators will illuminate when ignition switch is placed in LAMP TEST position.

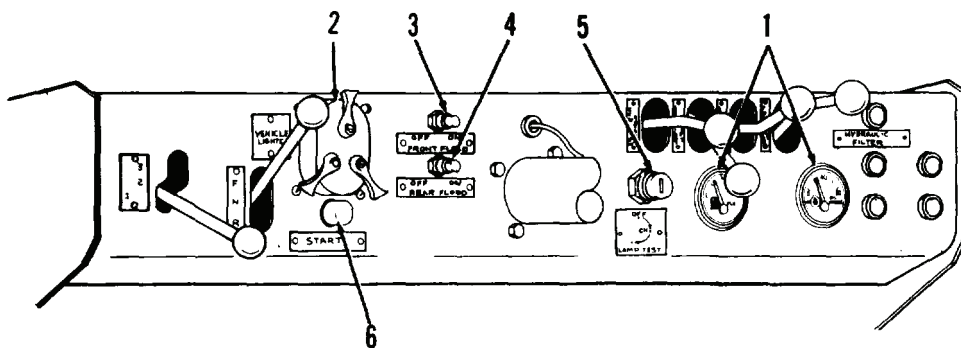
**Instrument Panel Switches and Gage Lights**

TA126851

1. GAGE LIGHTS. Provide illumination of oil pressure and fuel gages. Lamps are contained within these gages and are controlled by vehicle lights switch.
2. VEHICLE LIGHTS SWITCH. Consists of three separate sections: main switch, auxiliary switch, and mechanical lock. Main switch controls application of power to blackout tail and stop light, stop light switch, service taillight, and front and rear floodlight switches. Auxiliary switch controls application of power to gage lights and brightness of these lights, and power to service taillights. Mechanical lock prevents main and auxiliary switches from applying power to lights except blackout taillights.
3. FRONT FLOODLIGHTS SWITCH. Applies power to illuminate front floodlights.
4. REAR FLOODLIGHTS SWITCH. Applies power to illuminate rear floodlights.
5. IGNITION SWITCH. Four-position key switch. Unmarked position (key turned to left) applies power to vehicle lights switch enabling lights to be turned on. OFF position disconnects power from ignition and light system. ON position applies power to vehicle lights switch, gages, indicators (oil pressure and alternator lamps will illuminate), fuel pump, fuel injection pump, backup alarm switch, and start switch. Lamp test position applies power to illuminate hydraulic filter, transmission temperature, and engine temperature indicators.
6. START SWITCH. Applies power to energize starter relay by means of lockout relay and neutral start switch. With starter relay energized, starter solenoid energizes, in turn, cranking starter motor to start engine.

## TRANSMISSION AND DRIVE SHAFTS

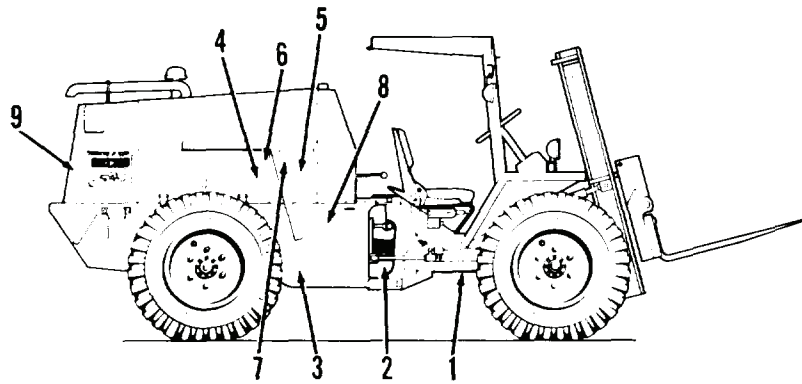

TA126852

1. **FRONT DRIVE SHAFT.** Connected between center drive shaft and front axle. Connected to front axle yoke by universal joint and to center drive shaft by a yoke with internal splines. Rear of front drive shaft is supported by a bearing.
2. **CENTER DRIVE SHAFT.** Connected between transmission output shaft and front drive shaft.
3. **REAR DRIVE SHAFT.** Connected between transmission output shaft and rear axle by universal joints.
4. **TORQUE CONVERTER.** Integral part of transmission. Multiplies engine power.
5. **TRANSMISSION.** Consists of torque converter, transmission, charging pump and filter, control valve assembly, modulation valve, and parking brake. Includes declutch feature that neutralizes transmission. This is accomplished by declutch valve spool in control valve assembly. Flow of hydraulic oil to declutch valve spool is controlled by declutch valve, which is mechanically linked to operator's declutch pedal.
6. **CHARGING PUMP AND FILTER.** Draws oil from transmission sump through oil suction screen and directs the oil through pressure regulating valve and filter. Filter removes impurities from oil.
7. **CONTROL VALVE ASSEMBLY.** Directs oil under pressure to desired directional and speed clutch. Directional and speed control valves connected by push-pull type cables to operator's transmission direction and speed selector levers.
8. **AXLE DISCONNECT.** Controls engagement and disengagement of transmission drive with front and rear axles. Pulling lever outward disconnects drive from front and rear axles; pushing lever inward engages drive. This is used only when truck is to be towed to a new location.
9. **TRANSMISSION OIL COOLER.** Mounted at rear of truck, in front of radiator. Cools transmission hydraulic oil.

## AXLES AND WHEELS

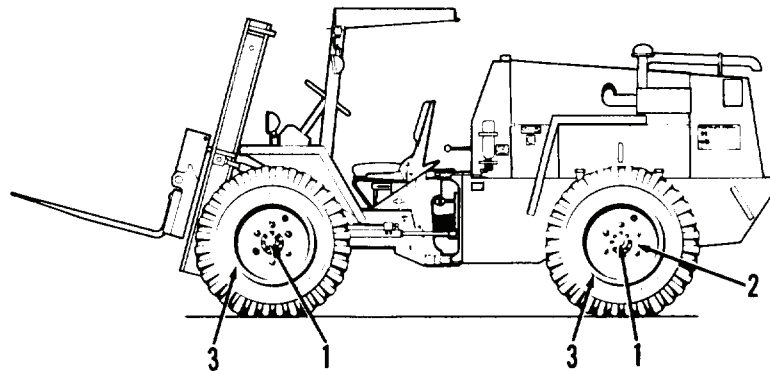

TA126853

1. FRONT AND REAR AXLES. Single reduction type driven by propeller shafts; front axle is rigidly mounted; rear axle is trunnion mounted. Axle includes differential carrier and drum type brakes on each wheel.
2. DIFFERENTIAL CARRIER. Integral part of axle; single reduction unit employs a heavy duty spiral bevel gear.
3. RIMS AND TIRES. Heavy duty steel rims; pneumatic tires, 15 by 19.5, 8-ply tubeless. Tires of replacement vehicle have a 14-ply rating.

## BRAKES

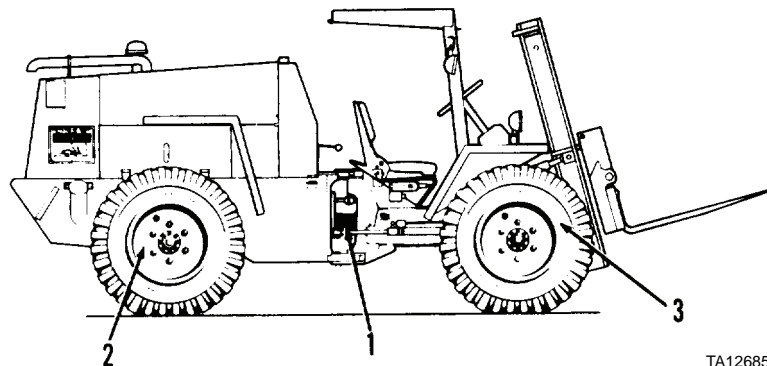

TA126854

1. PARKING BRAKE. Located on transmission output shaft; drum and shoe type brake. Actuated by lever located next to operator's seat and connected by cable to parking brake actuating lever.
2. SERVICE BRAKES. Floating shoe and drum hydraulic brake located on each wheel. Actuation of the brakes permits brake shoes to center themselves in brake drum.
3. HYDRAULIC BRAKE VALVE. Consists of power section (provides power assist to service brakes) and master cylinder section. Power assist section connected by plunger to service brake pedal.

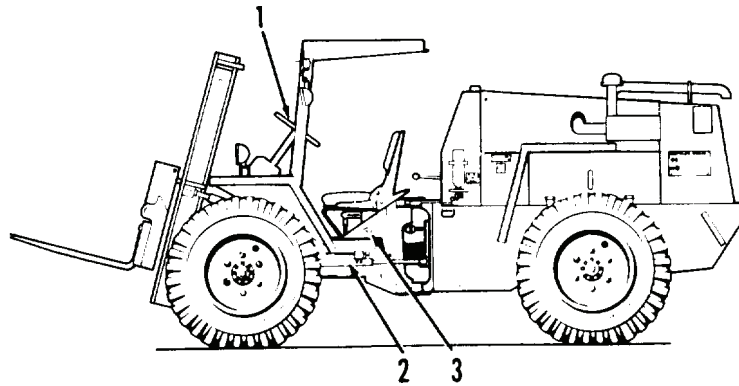
**STEERING SYSTEM**

TA126855

1. **STEERING GEAR ASSEMBLY.** Consists of steering column and rotary hydrostatic valve. Has four hydraulic connections. Operated by moving steering wheel attached to shaft of steering column. When turned, steering gear controls flow of hydraulic oil to and from steering cylinders. Connections for pump pressure line, return line, and right and left turn oil flow to steering cylinders. Lines from right and left ports connect to tees; lines from tees to steering cylinders are cross-connected so steering cylinders move in opposite directions when pressure is applied.
2. **STEERING CYLINDERS.** Two used, one mounted on each side of truck. Each end of cylinder attached to front and rear chassis.
3. **STEERING BYPASS VALVE.** When open, allows hydraulic oil to be transferred from one steering cylinder to the other for towing forklift truck.

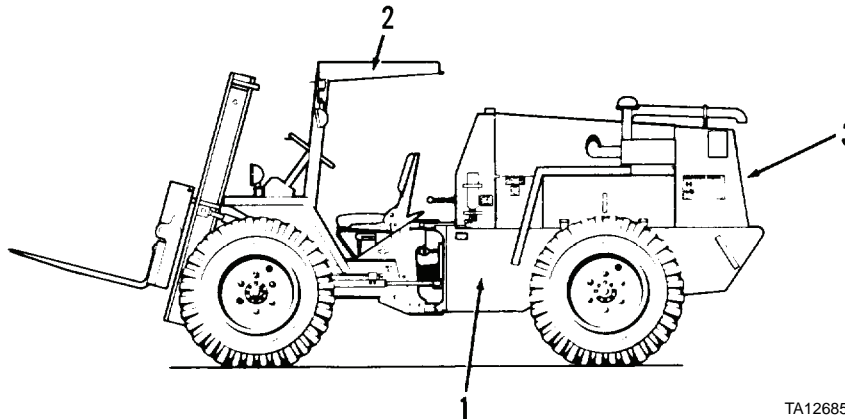
**BODY AND TOWING ATTACHMENTS**

TA126856

1. **BODY.** Constructed of heavy-duty steel. Consists of front and rear chassis to which are bolted front and rear fenders, engine hood and panels, and radiator shroud.
2. **ROLLOVER PROTECTIVE STRUCTURE (ROPS).** Constructed of heavy-duty steel. Bolted to front chassis. Protects operator from falling material and injuries due to truck rolling over.
3. **PINTLE AND TOW BAR.** Located at rear of truck. Pintle hook, tow bar, and chains used for towing truck or other vehicles.

## HYDRAULIC LIFT SYSTEM

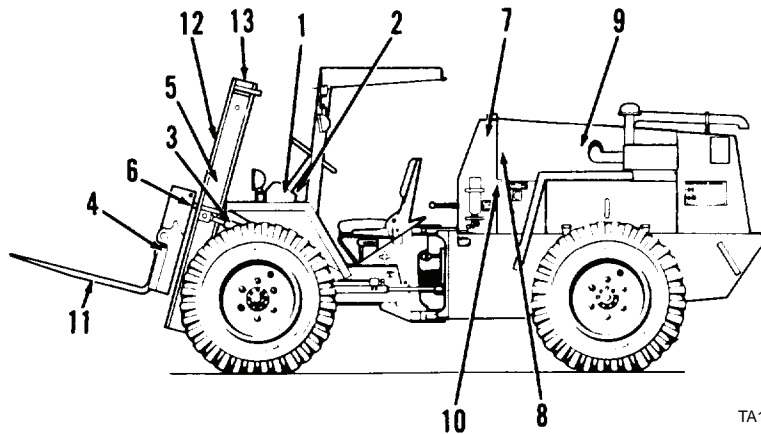

TA126857

1. **CONTROL VALVE.** Controls hydraulic oil flow to lift, tilt, rotation, and sideshift cylinders. Consists of an inlet and outlet section, four spool (working) sections and an end section. Each spool section controls a cylinder or pair of cylinders to move forks and mast.
2. **CONTROL LEVERS.** Positions control valve spools, in turn, allowing high-pressure hydraulic oil to activate cylinder.
3. **TILT CYLINDERS.** Two used. Activated by control valve. Tilts mast assembly forward or rearward. Minimum forward tilt is 11 degrees; minimum rearward tilt is 22 degrees.
4. **SIDESHIFT CYLINDER.** One used. Activated by control valve. Shifts fork carriage side-to-side.
5. **LIFT CYLINDER.** One used. Activated by control valve. Two-stage cylinder; raises or lowers fork carriage. Includes fitting at top for bleeding air from system.
6. **ROTATION CYLINDER.** One used. Activated by control valve. Rotates forks 10 degrees minimum clockwise and counterclockwise from horizontal position.
7. **HYDRAULIC RESERVOIR.** Integral part of rear chassis. Capacity is approximately 40 qt (38 L). Located to rear of operator's seat. Return oil filtered by 10 micron filter. Breather and oil filler located at top of reservoir. Oil screen located at bottom of reservoir in oil suction line.
8. **HYDRAULIC PUMP.** Mounted on rear of, and driven by, transmission. Also provides hydraulic power for steering system and service brakes. 11.4 GPM capacity. 2,500 PSI relief valve provided in hydraulic system to limit pump.
9. **HYDRAULIC FILTER.** Ten micron filter. Filters return oil. Located at rear of hydraulic reservoir. When clogged, **HYDRAULIC FILTER** indicator on instrument panel illuminates. Equipped with automatic bypass; opens at not less than 2 PSI and permits full flow at 3.5 PSI.
10. **HYDRAULIC SCREEN.** Located at bottom of hydraulic reservoir in hydraulic pump suction line. Filters hydraulic oil before it reaches hydraulic pump.
11. **LIFTING FORKS.** Two used. 40-in. (1,016-mm) forks. Constructed of heavy-duty steel.
12. **LIFT CHAINS.** Two used. Connect at one end to inner mast, reeved over chain rollers and connected at other end to carriage. Chains raise carriage.
13. **MAST ASSEMBLY.** Raises and lowers carriage by means of lift chains. Free lift height (height of forks without increased mast height) is not less than 48 in. Consists of outer and inner mast. Includes mast latch pin used to latch outer and inner mast between 0 to 12 in. height of lifting forks; disengages at over 12 in. height of lifting forks. Ensures free lift travel of not less than 48 in. (1,219 mm).

## END OF WORK PACKAGE





---

# INTRODUCTORY INFORMATION, EQUIPMENT DESCRIPTION AND DATA, AND THEORY OF OPERATION

## EQUIPMENT DESCRIPTION AND DATA

---

### TABULATED DATA

Refer to the separate Operator's Manual, TM 10-3930-638-10, for the following tabulated data: Equipment Purpose, Capabilities and Features; Location and Description of Major Components; and Performance Data (including capacities, dimensions and weight).

DATA, INSTRUCTION, AND WARRANTY PLATES

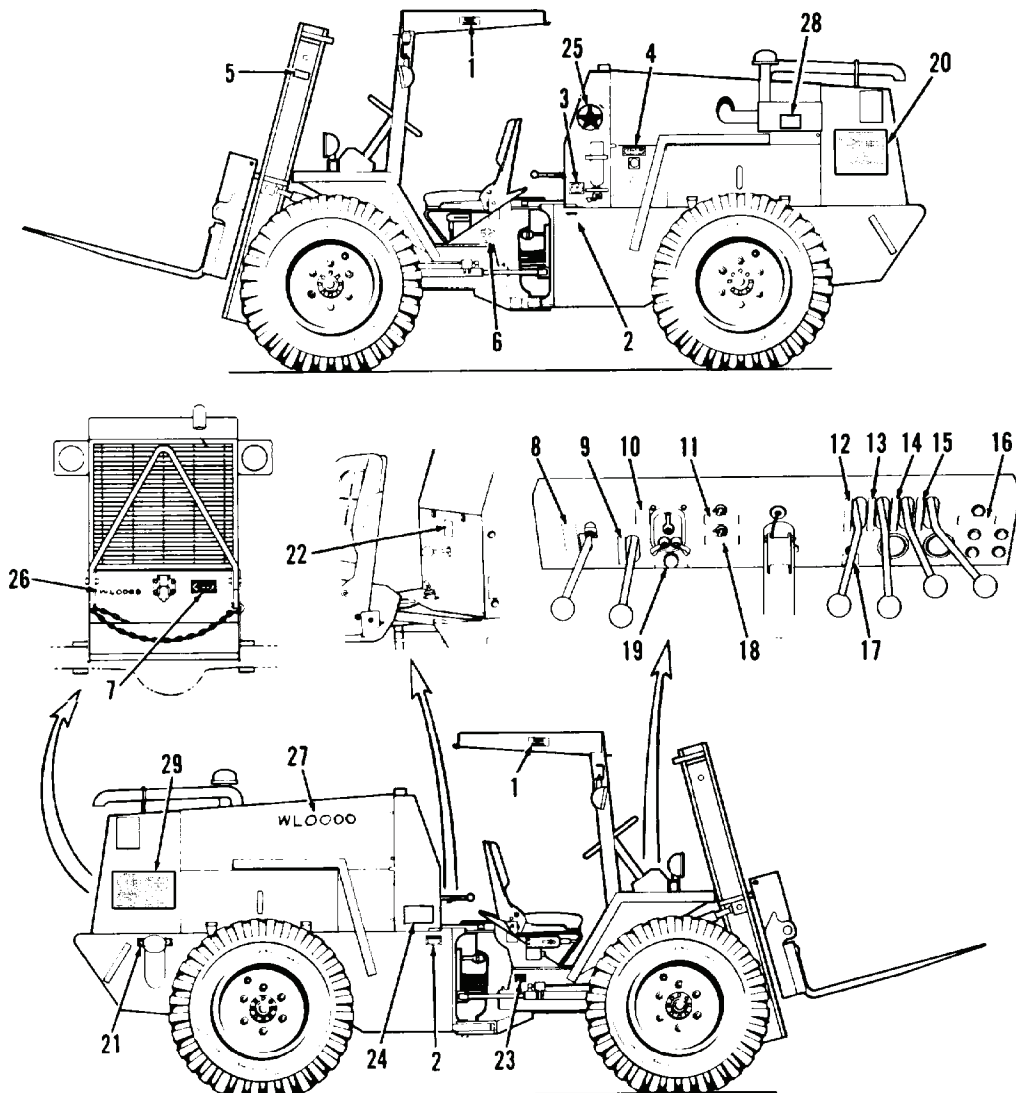

444-0021

DATA, INSTRUCTION, AND WARRANTY PLATES - CONTINUED

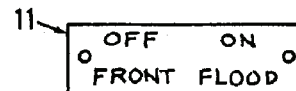
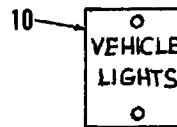
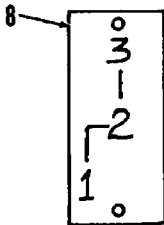
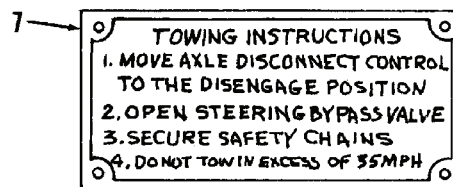
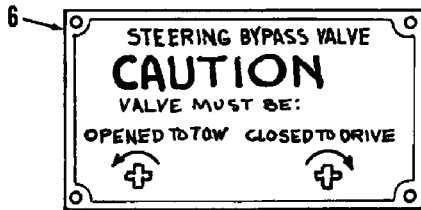
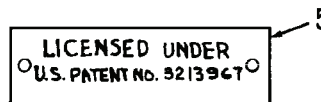
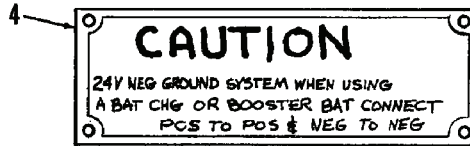

29

**MAINTENANCE SCHEDULE**  
MODEL 3000 FORKLIFT

ITEM	INTERVAL	DESCRIPTION	REMARKS
1	EVERY 100 HOURS OR DAILY	Check fluid levels in engine oil, hydraulic oil, and water.	See chart.
2	EVERY 100 HOURS OR DAILY	Check tire pressure and tread.	See chart.
3	EVERY 100 HOURS OR DAILY	Check steering and suspension.	See chart.
4	EVERY 100 HOURS OR DAILY	Check electrical system.	See chart.
5	EVERY 100 HOURS OR DAILY	Check safety devices.	See chart.
6	EVERY 100 HOURS OR DAILY	Check operator's seat and controls.	See chart.
7	EVERY 100 HOURS OR DAILY	Check exhaust system.	See chart.
8	EVERY 100 HOURS OR DAILY	Check fuel system.	See chart.
9	EVERY 100 HOURS OR DAILY	Check air filter.	See chart.
10	EVERY 100 HOURS OR DAILY	Check water pump.	See chart.
11	EVERY 100 HOURS OR DAILY	Check battery.	See chart.
12	EVERY 100 HOURS OR DAILY	Check engine oil.	See chart.
13	EVERY 100 HOURS OR DAILY	Check hydraulic oil.	See chart.
14	EVERY 100 HOURS OR DAILY	Check water level.	See chart.
15	EVERY 100 HOURS OR DAILY	Check battery water.	See chart.
16	EVERY 100 HOURS OR DAILY	Check battery electrolyte.	See chart.
17	EVERY 100 HOURS OR DAILY	Check battery terminals.	See chart.
18	EVERY 100 HOURS OR DAILY	Check battery connections.	See chart.
19	EVERY 100 HOURS OR DAILY	Check battery acid.	See chart.
20	EVERY 100 HOURS OR DAILY	Check battery case.	See chart.
21	EVERY 100 HOURS OR DAILY	Check battery vent caps.	See chart.
22	EVERY 100 HOURS OR DAILY	Check battery temperature.	See chart.
23	EVERY 100 HOURS OR DAILY	Check battery level.	See chart.
24	EVERY 100 HOURS OR DAILY	Check battery charge.	See chart.
25	EVERY 100 HOURS OR DAILY	Check battery voltage.	See chart.
26	EVERY 100 HOURS OR DAILY	Check battery current.	See chart.
27	EVERY 100 HOURS OR DAILY	Check battery capacity.	See chart.
28	EVERY 100 HOURS OR DAILY	Check battery efficiency.	See chart.

DATA, INSTRUCTION, AND WARRANTY PLATES - CONTINUED

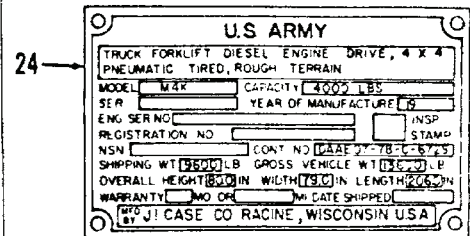
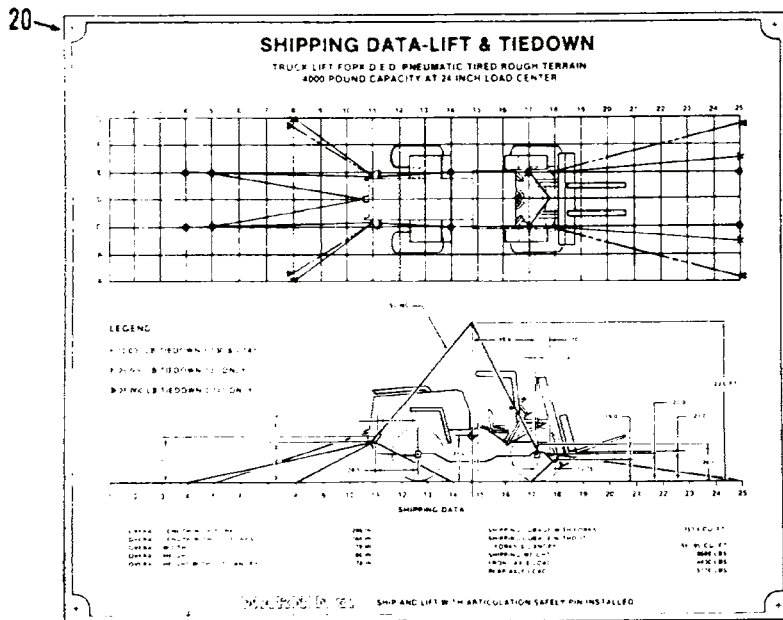
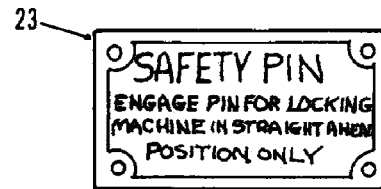
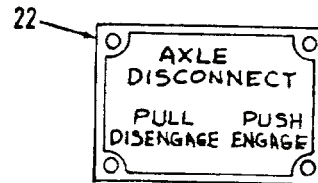
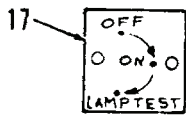
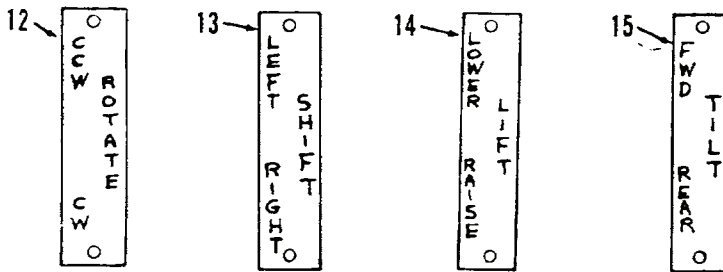

WL0000 26

WL0000 27

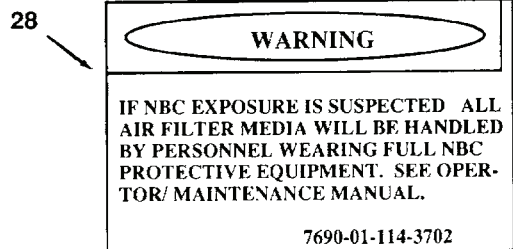

**EQUIPMENT DATA**

The following data covers the MHE 237 Forklift Truck on a case-by-case basis. Data unique to the replacement vehicle is in parentheses.

Engine

Manufacturer. . . . . Case, 207 (Case 4-390)  
 Model number. . . . . G207D (4-390)  
 Type. . . . . 4-stroke compression ignition diesel  
 Fuel system. . . . . Fuel injected  
 Horsepower (maximum BHP at 2,200 RPM). . . . . 60 (65)  
 Horsepower (SAE net at 2,200 RPM) . . . . . 55 (60)  
 Number of cylinders . . . . . 4  
 Bore. . . . . 4.0 in.  
 Stroke . . . . . 4-1/8 (4.72) in.  
 Compression ratio . . . . . 16.5 (19.1) to 1  
 Total displacement (cubic inches). . . . . 207 (239)  
 Firing order (right-hand rotation) . . . . . 1-3-4-2  
 Number of main bearings . . . . . 5  
 Oil filter. . . . . Full flow  
 Fan . . . . . 17 (17.7)-in., 6 (7) blade, pusher  
 Governor. . . . . Centrifugal, variable speed

Starter

Manufacturer. . . . . Delco Remy (Denso)  
 Model number. . . . . 1109051 (3970101)  
 Clutch . . . . . Sprag type

Alternator

Manufacturer. . . . . Delco Remy (Bosch)  
 Model number. . . . . 1103123 (K1-283)  
 Rating . . . . . 40 (45) amp

Air Cleaner

Manufacturer. . . . . Donaldson  
 Model number. . . . . FWG06-5131 (FHG 06-5305)  
 Type. . . . . Dry

Transmission

Manufacturer. . . . . Clark  
 Model . . . . . 11.2 HR18340  
 Type. . . . . Full power shift

Ratio

1st, forward and reverse. . . . . 10.81:1  
 2nd . . . . . 4.73:1  
 3rd . . . . . 1.58:1

**EQUIPMENT DATA - CONTINUED**

Torque converter (Integral with transmission)

Manufacturer ..... Clark  
 Model ..... 11.2 Integral  
 Stall ratio ..... 2.6:1

Axles

Manufacturer ..... Rockwell  
 Model  
     Front ..... D-140-FSHX18  
     Rear ..... D-140-FSHX18  
 Final axle ratio ..... 6.80:1

Tires

Size ..... 15x19,5  
 Type ..... 8-ply non-directional duplex  
 Normal tire pressure ..... 45 PSI

Hydraulic pump

Manufacturer ..... Cessna  
 Model ..... X24501-RAC  
 Type ..... Gear  
 Flow (at 2,000 RPM) at 2,000 PSI ..... 11.4 GPM  
 Pressure ..... 2,500 PSI

Steering Gear

Manufacturer ..... TRW  
 Model ..... HGA-32  
 Type ..... Hydrostatic

Hydraulic control valve

Manufacturer ..... Gresen  
 Model ..... V20-546-A  
 Type ..... Open center, parallel circuit  
 Relief setting ..... N/A

Hydraulic cylinders

Tilt ..... 3 in. diameter x 12.17 in. stroke x 1.5 in. rod  
 Lift ..... 2 stage  
 Steering ..... 2.12 in. diameter x 15 in. stroke x 1.25 in. rod  
 Side shift (mast) ..... 2.5 in. diameter x 22.12 in. stroke x 1.25 in. rod  
 Rotation (fork carrier) ..... 2.5 in. diameter x 7.2 in. stroke x 1 in. rod

---

**EQUIPMENT DATA - CONTINUED**

Electrical system

Voltage ..... 24  
Ground ..... Neg  
Batteries ..... 2 to 12V  
Number of headlights, standard and blackout ..... 5  
Number rear floodlights ..... 2  
Type headlights, blackout headlights, and rear floodlights. .... Sealed beam  
Number of taillights (combination tail, blackout, and stop light). .... 4 (2 Service, 2 Blackout)

**END OF WORK PACKAGE**





**CHAPTER 2**  
**ORGANIZATIONAL TROUBLESHOOTING PROCEDURES**



---

# ORGANIZATIONAL TROUBLESHOOTING PROCEDURES

## ORGANIZATIONAL TROUBLESHOOTING PROCEDURES INTRODUCTION

---

### INTRODUCTION

1. Troubleshooting procedures in this chapter contain information you need to locate fault malfunctions on the MHE 237 Forklift Truck and its components.
2. A *Troubleshooting Symptom Index* in WP 0005 is provided to aid in locating a malfunction or symptom and directs you to the appropriate troubleshooting procedure.
3. Troubleshooting procedures in this manual cannot provide all the answers or correct all malfunctions encountered. However, these procedures are an organized step-by-step approach to a problem that provide tests and inspections toward identifying the source of the problem and its successful resolution.
4. If a malfunction is not listed in the *Troubleshooting Symptom Index* in WP 0005, or stated tests or inspections and corrective actions do not correct the problem, notify your supervisor.
5. Before performing troubleshooting, read and follow all safety instructions found in the *Warning Summary* at the front of this manual.

### EXPLANATION OF TROUBLESHOOTING TABLE COLUMNS

The columns in the tables in each troubleshooting work package are defined as follows:

1. **MALFUNCTION**. A visual or operational indication that something is wrong with the equipment.
2. **TEST OR INSPECTION**. A procedure to isolate the problem in a system or component.
3. **CORRECTIVE ACTION**. A procedure to correct the problem.

### END OF WORK PACKAGE



# ORGANIZATIONAL TROUBLESHOOTING PROCEDURES

## ORGANIZATIONAL TROUBLESHOOTING SYMPTOM INDEX

<u>Malfunction/Symptom</u>	<u>Troubleshooting Procedure Page</u>
<b>Engine</b>	
1. Engine Hard To Start or Will Not Start.....	.0006-1
2. Engine Hard to Start or Will Not Start (Exhaust Smoke).....	.0006-5
3. Engine Starts But Will Not Run.....	.0006-5
4. Engine Misfires.....	.0006-7
5. Engine Stalls Frequently or Does Not Develop Full Power.....	.0006-9
6. Engine Cranks But Does Not Start When Quick Start is Activated.....	.0006-12
7. Excessive Oil Consumption.....	.0006-13
8. Low Engine Oil Pressure.....	.0006-13
9. Engine Will Not Shut Down.....	.0006-14
<b>Fuel System</b>	
1. Low Fuel Pressure.....	.0007-1
2. Excessive Fuel Usage.....	.0007-2
<b>Exhaust System</b>	
1. Excessive Exhaust Noise.....	.0008-1
2. Excessive Exhaust Smoke.....	.0008-1
<b>Cooling System</b>	
1. Engine Overheats.....	.0009-1
2. Engine Does Not Reach Operating Temperature.....	.0009-1
3. Cooling System Not Pressurized.....	.0009-2
<b>Battery System (Model 207)</b>	
1. All Electrical Systems Are Weak.....	.0010-1
2. Batteries are Hot or Use Excessive Water.....	.0010-2
<b>Battery System (Model 4-390)</b>	
1. All Electrical Systems Are Weak.....	.0011-1
2. Batteries Are Hot or Use Excessive Water.....	.0011-2
<b>Starting System (Model 207)</b>	
1. Starter Cranks Too Slowly.....	.0012-1
2. Starter Fails to Crank.....	.0012-2
3. Starter Cranks Continuously.....	.0012-3
<b>Starting System (Model 4-390)</b>	
1. Starter Fails To Crank.....	.0013-1
2. Starter Cranks Too Slowly.....	.0013-1

<u>Malfunction/Symptom</u>	<u>Troubleshooting Procedure Page</u>
<b>Charging System (Model 207)</b>	
1. Abnormal Alternator Light Operation. . . . .	.0014-1
2. Alternator Output Low, Unsteady, or Zero. . . . .	.0014-2
<b>Charging System (Model 4-390)</b>	
1. Instrument Panel Light for Alternator Comes On When Engine is Running. . . . .	.0015-1
2. Alternator Output Low, Unsteady, or Zero. . . . .	.0015-1
<b>Horn and Back-Up Alarm System</b>	
1. Horn Does Not Sound. . . . .	.0016-1
2. Back-up Alarm Does Not Sound. . . . .	.0016-2
<b>Light Systems</b>	
1. Front Floodlights Inoperative. . . . .	.0017-1
2. Front Blackout Light Inoperative. . . . .	.0017-2
3. Blackout Taillights Inoperative. . . . .	.0017-3
4. Service Taillights Inoperative. . . . .	.0017-3
5. Blackout Stop Lights Inoperative. . . . .	.0017-4
6. Service Stop Lights Inoperative. . . . .	.0017-5
7. Rear Floodlights Inoperative. . . . .	.0017-6
8. Gage Lights Inoperative. . . . .	.0017-7
<b>Instrument Panel</b>	
1. Warning Lights Inoperative. . . . .	.0018-1
2. Warning Lights, Back-up Alarm, and Electric Fuel Pump Inoperative. . . . .	.0018-2
<b>Transmission</b>	
1. Foamy Oil. . . . .	.0019-1
2. Slow or Erratic Transmission Shifting. . . . .	.0019-2
3. High Transmission Oil Temperature. . . . .	.0019-2
4. Loss of Drive in All Ranges. . . . .	.0019-3
5. Loss of Power. . . . .	.0019-4
<b>Axles and Drive Shaft Assemblies</b>	
1. Lubricant Leaking From Differential Breather. . . . .	.0020-1
2. Continuous Axle or Wheel Noise. . . . .	.0020-1
3. Differential Carrier Assembly Overheating. . . . .	.0020-1
4. Lubricant Leaking From Differential Carrier Assembly. . . . .	.0020-1
5. Excessive Noise or Vibration in Drive Shaft Assemblies. . . . .	.0020-2
<b>Brake System</b>	
1. Parking Brake Does Not Apply (Will Not Hold). . . . .	.0021-1
2. Uneven or Erratic Service Brakes. . . . .	.0021-1
3. Service Brakes Spongy. . . . .	.0021-2
4. Service Brakes Grab. . . . .	.0021-3
5. Service Brakes Squeak. . . . .	.0021-4
6. Service Brakes Overheat. . . . .	.0021-5

**Malfunction/Symptom**

**Troubleshooting Procedure Page**

**Brake System - Continued**

7. Excessive Service Brake Pedal Travel. . . . .0021-6  
 8. Excessive Service Brake Pedal Effort Required. . . . .0021-7  
 9. Service Brakes Groan at End of Stop. . . . .0021-8  
 10. Scraping Noise From Service Brakes When Applied. . . . .0021-9  
 11. Stop Light Inoperative. . . . .0021-10  
 12. Declutch Pedal Does Not Neutralize Transmission. . . . .0021-10

**Wheels and Tires**

1. Tire Wearing Unevenly. . . . .0022-1  
 2. Noisy or Bumping Sound While Traveling. . . . .0022-1

**Steering System**

1. Vehicle Will Not Turn When Steering Wheel is Turned. . . . .0023-1  
 2. Vehicle Turns Correctly in One Direction But Not in Other Direction. . . . .0023-1  
 3. Steering Wheel Turns Hard or Vehicle Turns Too Slowly. . . . .0023-3  
 4. Effort to Turn in One Direction is More Than Required in Other Direction. . . . .0023-4

**Frame and Towing Attachments**

1. Pintle Hook Stuck. . . . .0024-1  
 2. Loud Clunk Heard When Vehicle Turns. . . . .0024-1  
 3. Tow Bar Does Not Pivot or Latch. . . . .0024-1

**Body, Cab, and Hoot**

1. Side Panel Does Not Latch. . . . .0025-1  
 2. Seat Will Not Adjust. . . . .0025-1

**Hydraulic Lift System**

1. Load Lowers Too Fast. . . . .0026-1  
 2. Load Creeps Downward. . . . .0026-1  
 3. Unable To Lift, Tilt, Shift, or Rotate Load. . . . .0026-2  
 4. Lift, Tilt, Shift, or Rotate Too Slow. . . . .0026-3  
 5. Load Creeps While Tilting. . . . .0026-3

**Gages**

1. Engine Oil Pressure Gage Does Not Indicate Correct Pressure. . . . .0027-1  
 2. Fuel Gage Does Not Register. . . . .0027-2  
 3. Fuel Gage Does Not Indicate Correct Fuel Level. . . . .0027-2

**END OF WORK PACKAGE**





# ORGANIZATIONAL TROUBLESHOOTING PROCEDURES

## ENGINE TROUBLESHOOTING

MALFUNCTION	TEST OR INSPECTION	CORRECTIVE ACTION
-------------	--------------------	-------------------

### 1. ENGINE HARD TO START OR WILL NOT START.



WARNING



If NBC exposure is suspected, all air filter media should be handled by personnel wearing protective equipment. Consult your unit NBC Officer or NBC NCO for appropriate handling or disposal procedures.

- Step 1. Check if air cleaner indicator red flag is in view.
  - a. If in view, depress reset button on tip of indicator and ensure red flag disappears from view. (If red flag does not disappear from view, replace air cleaner indicator as described in WP 0061.) Crank engine and check if red flag is in view; if red flag is in view, service air cleaner (WP 0061) for original vehicle or WP 0062 for replacement vehicle.
  - b. If red flag is not in view, proceed to step 2 below.

- Step 2. Check if fuel shut-off valve is in OFF position (original vehicle).
  - a. If fuel shut-off valve is in OFF position, place in ON position as shown.
  - b. If fuel shut-off valve is in ON position, proceed to step 3.

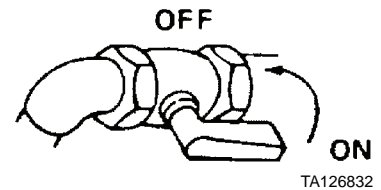

- Step 3. Check if there is fuel in fuel tank.
  - a. If no fuel in fuel tank, fill tank.
  - b. If fuel in fuel tank, proceed to step 4.

- Step 4. Check for air in fuel system (original vehicle).
  - a. Place ignition switch in ON position. Open bleed valve plug on top of secondary fuel filter allowing air to bleed out of both filters. When fuel, free of bubbles, starts to flow, close bleed valve plug and wipe parts free of fuel. Place ignition switch in OFF position.
  - b. If no air in fuel system, proceed to step 5.

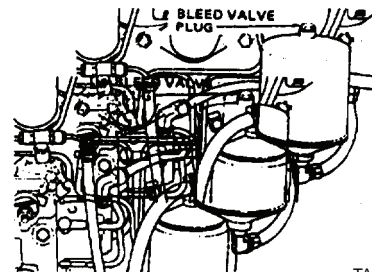

- Step 5. Check for leaks at fittings between fuel tank and fuel injection pump.
  - a. If leaks are observed, tighten or replace fittings (WP 0065 for original vehicle or WP 0066 for replacement vehicle).
  - b. If leaks are not observed, proceed to step 6.

**MALFUNCTION**  
**TEST OR INSPECTION**  
**CORRECTIVE ACTION**

**1. ENGINE HARD TO START OR WILL NOT START (CONTINUED).**

Step 6. Disconnect fuel line at fuel filter head (original vehicle). Place ignition switch in ON position and check if a slight buzz can be heard at electric fuel pump and if fuel is pumped out of disconnected line.

a. If slight buzz indicating electric fuel pump operation is not heard, disconnect wire at terminal on electric fuel pump and check for +24 VDC between wire and chassis ground.

1. If +24 VDC is not obtained, troubleshoot electrical system (WP 0005).
2. If +24 VDC is obtained, replace electric fuel pump (WP 0059).

b. If fuel is not pumped out of disconnected fuel line, remove lines and fittings between fuel tank and fuel filter head and clean/replace lines, in-line fuel filter, and/or fuel strainer (WP 0065, WP 0067, WP 0069, and WP 0070).

c. If fuel is pumped out of disconnected fuel line, proceed to step 7.

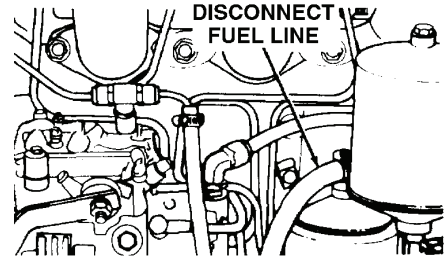

ORIGINAL VEHICLE 444-0026

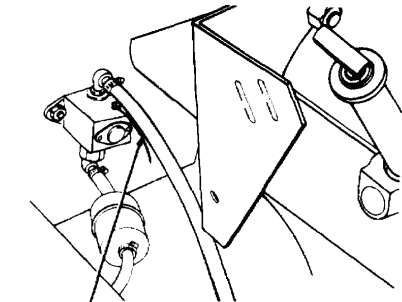

DISCONNECT WIRE  
 ORIGINAL VEHICLE 444-0027

Step 7. Check for clogged fuel filters by disconnecting fuel line between fuel filter head and fuel injection pump at fuel injection pump.

Place ignition switch in ON position and crank engine. Fuel should be pumped out of disconnected line.

a. If fuel is not pumped out of disconnected line, reconnect fuel line and service fuel filters (WP 0067 and WP 0069 for original vehicle or WP 0068 and WP 0072 for replacement vehicle).

b. If fuel is pumped out of disconnected line, reconnect fuel line and proceed to step 8.

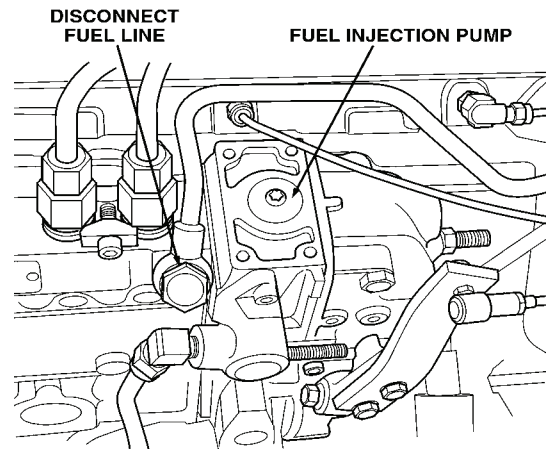

REPLACEMENT VEHICLE 444-0028

---

**MALFUNCTION**  
**TEST OR INSPECTION**  
**CORRECTIVE ACTION**

---

**1. ENGINE HARD TO START OR WILL NOT START (CONTINUED).**

Step 8. Disconnect wire at fuel injection pump terminal (original vehicle). With ignition switch in ON position, check for +24 VDC between wire and chassis ground.

- a. If +24 VDC is obtained, reconnect wire to terminal and crack (open) a fuel injection line at fuel injection pump. Crank engine and check if fuel is pumped through fuel injection pump.
  1. If fuel is pumped, proceed to step 9.
  2. If fuel is not pumped, replace fuel injection pump (notify Direct Support Maintenance).
- b. If +24 VDC is obtained, troubleshoot electrical system (WP 0005).

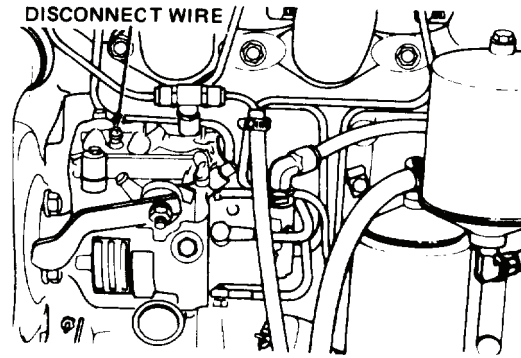

TA126861

Step 9. Check for incorrect or contaminated fuel in fuel tank (if contaminated, fuel will have milky white coloring).

- a. If fuel is contaminated, drain fuel tank, clean and fill with correct fuel (WP 0063 or WP 0064) and replace fuel filters (WP 0067 and WP 0069 for original vehicle or WP 0068 and WP 0072 for replacement vehicle).
- b. If fuel is not contaminated, proceed to step 10.

**MALFUNCTION**  
**TEST OR INSPECTION**  
**CORRECTIVE ACTION**

**1. ENGINE HARD TO START OR WILL NOT START (CONTINUED).**

- Step 10. Check for loose fuel injector nozzle.
- a. If a fuel injector nozzle is loose, tighten clamp or nozzle.
  - b. If fuel injector nozzles are not loose, proceed to step 11.

**FUEL INJECTOR  
NOZZLES AND  
CLAMPS**

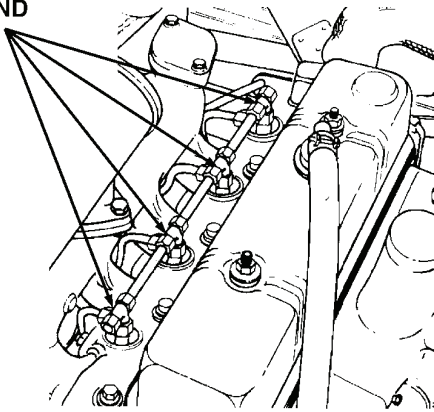

**ORIGINAL VEHICLE**

444-0029

**FUEL INJECTOR  
NOZZLES**

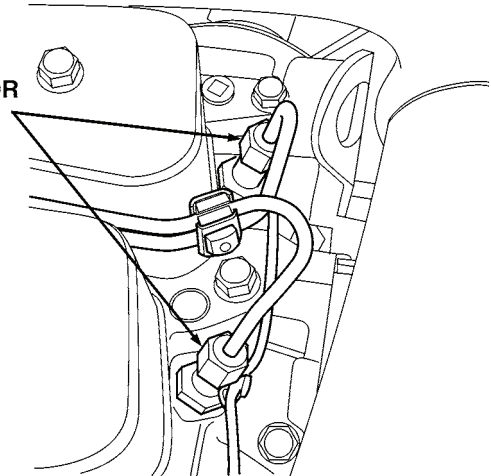

**REPLACEMENT VEHICLE**

444-0030

- Step 11. Check for damaged fuel injector nozzle seal or damaged nozzle (notify Direct Support Maintenance).
- a. If fuel injector nozzle seal or nozzle is damaged, replace (notify Direct Support Maintenance).
  - b. If fuel injector nozzle seal and nozzle are okay, proceed to step 12.

- Step 12. Disconnect ground cable from battery.
- a. Disconnect battery cable from starter B terminal and connect to ammeter. Connect a test cable from ammeter to starter B terminal.
  - b. Connect ground cable to battery.
  - c. Place ignition switch in ON position and depress start pushbutton while observing ammeter.

**B TERMINAL  
DISCONNECT  
BATTERY CABLE**

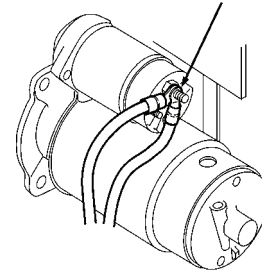

**ORIGINAL VEHICLE**

444-0031

---

**MALFUNCTION**  
**TEST OR INSPECTION**  
**CORRECTIVE ACTION**

---

**1. ENGINE HARD TO START OR WILL NOT START (CONTINUED).**

Ammeter should indicate 75 to 95 amperes.

- a. If ammeter reading is higher than 95 amperes, replace starter (WP 0095 for original vehicle WP 0096 for replacement vehicle).
- b. If ammeter reading is less than 75 amperes, check battery (WP 0010 or WP 0011, MALFUNCTION 1, step 3). If battery checks good, replace battery cables (WP 0133 for original vehicle or WP 0134 for replacement vehicle).
- c. If ammeter reading is 75 to 95 amperes, notify Direct Support Maintenance.

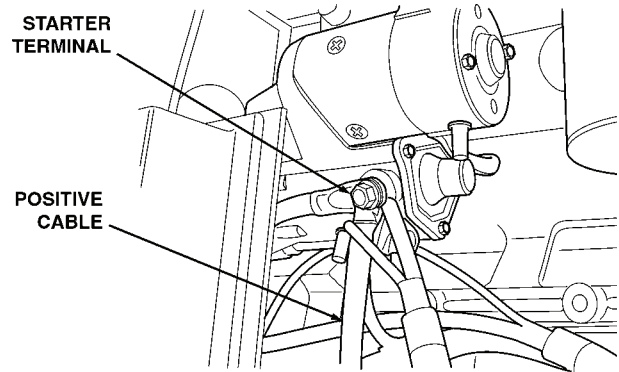

REPLACEMENT VEHICLE

444-0032

**2. ENGINE HARD TO START OR WILL NOT START (EXHAUST SMOKE).**

**NOTE**

Also refer to MALFUNCTION 1, steps 1, 2, 7 through 9, and 11.

- Step 1. Check for fuel leaks at fuel injector lines.
  - a. If fuel leaks are observed, tighten or replace lines (notify Direct Support Maintenance).
  - b. If fuel lines are okay, proceed to step 2.
- Step 2. Remove radiator cap and observe coolant for gas bubbles while cranking engine.
  - a. If gas bubbles rising in coolant are observed, replace cylinder head gasket. Notify Direct Support Maintenance.

**3. ENGINE STARTS BUT WILL NOT RUN.**



**WARNING**



If NBC exposure is suspected, all air filter media should be handled by personnel wearing protective equipment. Consult your unit NBC officer or NBC NCO for appropriate handling or disposal procedures.

- Step 1. Check if air cleaner red flag is in view.
  - a. If in view, depress reset button on top of indicator and ensure red flag disappears from view. (If red flag does not disappear from view, replace air cleaner indicator as described in WP 0061 for original vehicle or WP 0062 for replacement vehicle.)
  - b. If red flag is not in view, proceed to step 2.
- Step 2. Check if there is fuel in fuel tank.
  - a. Fill fuel tank if no fuel in fuel tank.
  - b. If fuel in fuel tank, proceed to step 3.

---

**MALFUNCTION**  
**TEST OR INSPECTION**  
**CORRECTIVE ACTION**

---

**3. ENGINE STARTS BUT WILL NOT RUN (CONTINUED).**



**WARNING**



If NBC exposure is suspected, all air filter media should be handled by personnel wearing protective equipment. Consult your unit NBC officer or NBC NCO for appropriate handling or disposal procedures.

Step 3. Check for air in fuel system (original vehicle).

- a. Place ignition switch in ON position. Open bleed valve plug on top of secondary fuel filter allowing air to bleed out of both filters. When fuel, free of bubbles, starts to flow, close bleed valve plug and wipe parts free of fuel. Turn ignition switch OFF.
- b. If no air in fuel system, proceed to step 4.

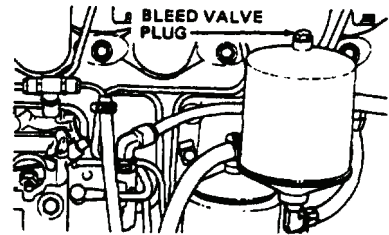

Step 4. Check for clogged fuel filters by disconnecting fuel line between fuel filter head and fuel injection pump at fuel injection pump. Place ignition switch in ON position and crank engine. Fuel should be pumped out of disconnected line.

- a. If fuel is not pumped out of disconnected line, reconnect fuel line and service fuel filters (WP 0065 and WP 0067 for original vehicle or WP 0066 and WP 0068 for replacement vehicle).
- b. If fuel is pumped out of disconnected line, reconnect line and proceed to step 5.

Step 5. Check for incorrect or contaminated fuel in fuel tank (if contaminated, fuel will have a milky white coloring).

- a. If fuel is contaminated, drain fuel tank, clean, and fill with correct fuel (WP 0064) for original vehicle and WP 0065 for replacement vehicle. Replace fuel filters (WP 0067 and WP 0069 for original vehicle or WP 0068 and WP 0072 for updated vehicle).  
Refer to LO 10-3930-638-12 for correct fuel.
- b. If fuel is not contaminated, proceed to step 6.

Step 6. Check throttle cable movement as an assistant depresses and releases accelerator.

- a. If movement is not observed, repair or replace throttle/accelerator pedal linkage (WP 0074 for original vehicle or WP 0075 for replacement vehicle).
- b. If movement is observed, proceed to step 7.

---

**MALFUNCTION**  
**TEST OR INSPECTION**  
**CORRECTIVE ACTION**

---

**3. ENGINE STARTS BUT WILL NOT RUN (CONTINUED).**

- Step 7. Disconnect wire at fuel injection pump terminal (original vehicle). With ignition switch in ON position, check for +24 VDC between wire and chassis ground.
- a. If +24 VDC is obtained, reconnect wire to terminal and crack (open) a fuel injector line at fuel injector pump. Crank engine and check if fuel is pumped through fuel injection pump.
    1. If fuel is pumped through injection pump, proceed to step 8.
    2. If fuel is not pumped through fuel injection pump, replace it (notify Direct Support Maintenance).
  - b. If +24 VDC is not obtained, troubleshoot electrical system (WP 0005).
  - c. If fuel is pumped out of disconnected fuel line, proceed to step 8.

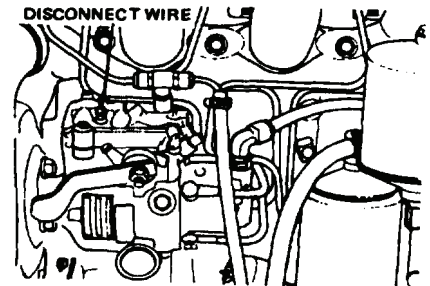

TA2-16b

- Step 8. Check for fuel leaks at fuel injector lines.
- a. If fuel leaks are observed, tighten or replace lines. Notify Direct Support Maintenance.
  - b. If fuel lines are okay, proceed to step 9.

- Step 9. Remove radiator cap, start engine, and observe coolant for gas bubbles.  
 If gas bubbles rising in coolant are observed, replace cylinder head gasket. Notify Direct Support Maintenance.

**4. ENGINE MISFIRES.**

- Step 1. Check for incorrect or contaminated fuel in fuel tank (if contaminated, fuel will have a milky white appearance).
- a. If fuel is contaminated, drain fuel tank, clean and fill with correct fuel (WP 0064 for original vehicle and WP 0065 for replacement vehicle). Replace fuel filters (WP 0067 and WP 0069 for non-updated vehicle or WP 0068 and WP 0072 for updated vehicle).
  - b. If fuel is not contaminated, proceed to step 2.
- Step 2. Operate engine for 15 minutes at idle speed.
- a. Carefully and slowly remove radiator cap.
  - b. Check coolant temperature using a thermometer. Be sure thermometer does not touch any metal parts of radiator.
  - c. Coolant temperature should be 175 to 200°F (79 to 93°C).
    1. If coolant temperature is not 175 to 200°F (79 to 93°C), remove and test thermostat.
    2. If coolant temperature is 175 to 200°F (79 to 93°C), proceed to step 3.

---

MALFUNCTION	TEST OR INSPECTION	CORRECTIVE ACTION
-------------	--------------------	-------------------

---

#### 4. ENGINE MISFIRES (CONTINUED).

- Step 3. Check for fuel leaks at fuel injector lines.
- If fuel leaks are observed, tighten or replace lines. Notify Direct Support Maintenance.
  - If fuel lines are okay, proceed to step 4.

- Step 4. Check for loose fuel injector nozzle.
- If a fuel injector nozzle is loose, tighten clamp or nozzle.
  - If fuel injector nozzles are not loose, proceed to step 5.

**FUEL INJECTOR  
NOZZLES AND  
CLAMPS**

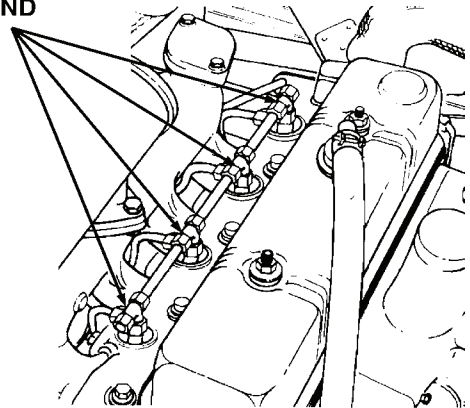

**ORIGINAL VEHICLE**

444-0029

- Step 5. Disconnect wire at fuel injection pump terminal (original vehicle). With ignition switch in ON position, check for +24 VDC between wire and chassis ground.
- If +24 VDC is obtained, reconnect wire to terminal and crack (open) a fuel injector line at fuel injection pump.
  - Crank engine and check if fuel is pumped through fuel injection pump.
    - If fuel is pumped through injection pump, notify Direct Support Maintenance.
    - If fuel is not pumped through fuel injection pump, replace pump (notify Direct Support Maintenance).
  - If +24 VDC is not obtained, troubleshoot electrical system (WP 0005).

**FUEL INJECTOR  
NOZZLES**

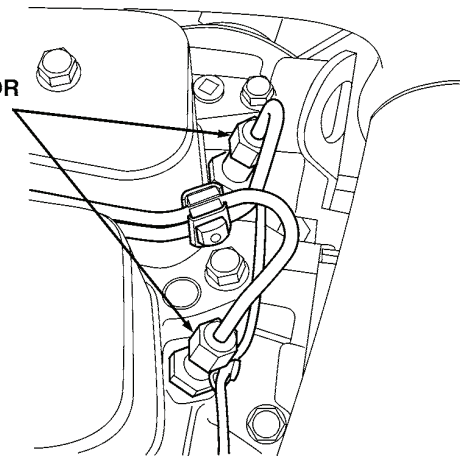

**REPLACEMENT VEHICLE**

444-0030



---

**MALFUNCTION**  
**TEST OR INSPECTION**  
**CORRECTIVE ACTION**

---

**5. ENGINE STALLS FREQUENTLY OR DOES NOT DEVELOP FULL POWER.**



**WARNING**



If NBC exposure is suspected, all air filter media should be handled by personnel wearing protective equipment. Consult your unit NBC officer or NBC NCO for appropriate handling or disposal procedures.

- Step 1. Check if air cleaner indicator red flag is in view.
- If in view, depress reset button on top of indicator and ensure red flag disappears from view. (If red flag does not disappear from view, replace air cleaner indicator as described in WP 0061 for original vehicle or WP 0062 for replacement vehicle.) Crank engine and check if red flag is in view; if in view, service air cleaner (WP 0061 or WP 0062).
  - If red flag is not in view, proceed to step 2.

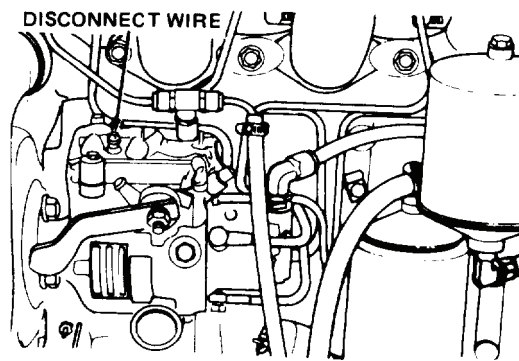

TA126861

- Step 2. With engine operating at idle speed, squirt small amount of oil on intake manifold where it contacts cylinder head.
- Check if oil is drawn into intake manifold indicating intake manifold gasket is damaged.
- If oil is drawn into intake manifold, remove and replace intake manifold gasket (WP 0053 for original vehicle or WP 0054 for replacement vehicle).
  - If oil is not drawn into intake manifold, proceed to step 3.
- Step 3. Check engine oil level dipstick for overfilled engine crankcase.
- If engine crankcase is overfilled as indicated by dipstick, drain excess oil until level is just below FULL mark on dipstick (WP 0049 for original vehicle or WP 0050 for replacement vehicle).
  - If engine oil level is okay, proceed to step 4.

---

**MALFUNCTION**  
**TEST OR INSPECTION**  
**CORRECTIVE ACTION**

---

**5. ENGINE STALLS FREQUENTLY OR DOES NOT DEVELOP FULL POWER (CONTINUED).**

Step 4. Check for air in fuel system (original vehicle).

- a. Place ignition switch in ON position. Open bleed valve plug on top of secondary fuel filter allowing air to bleed out of both filters. When fuel, free of bubbles, starts to flow, close bleed valve plug and wipe parts free of fuel. Turn ignition switch OFF.
- b. If no air in fuel system, proceed to step 5.

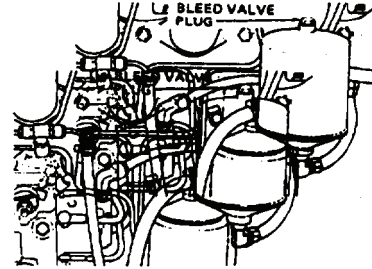

TA126858

Step 5. Check for incorrect or contaminated fuel in fuel tank (if contaminated, fuel will have a milky white coloring).

- a. If fuel is contaminated, drain fuel tank, clean and fill with correct fuel (WP 0064 for original vehicle and WP 0065 for replacement vehicle). Replace fuel filters (WP 0067 and WP 0069 for original vehicle or WP 0068 and WP 0072 for replacement vehicle). (Refer to LO 10-3930-638-12 for correct fuel.)
- b. If fuel is not contaminated, proceed to step 6.

Step 6. Check for clogged fuel filters by disconnecting fuel line between fuel filter head and fuel injection pump at fuel injection pump.

- a. Place ignition switch in ON position and crank engine.
- b. Fuel should be pumped out of disconnected line.
  1. If fuel is not pumped out of disconnected line, reconnect fuel line and service fuel filters (WP 0067 and WP 0069 for original vehicle or WP 0068 and WP 0072 for replacement vehicle).
  2. If fuel is pumped out of disconnected line, reconnect fuel line and proceed to step 7.

**MALFUNCTION**  
**TEST OR INSPECTION**  
**CORRECTIVE ACTION**

**5. ENGINE STALLS FREQUENTLY OR DOES NOT DEVELOP FULL POWER (CONTINUED).**

Step 7. Disconnect fuel line at fuel filter head (original vehicle). Place ignition switch in ON position and check if a slight buzz can be heard at electric fuel pump and if fuel is pumped out of disconnected line.

a. If slight buzz indicating electric fuel pump operation is not heard, disconnect wire at terminal on electric fuel pump and check for +24 VDC between wire and chassis ground.

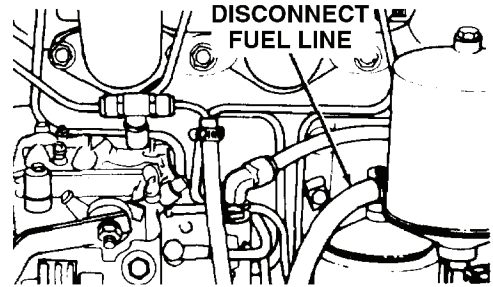

ORIGINAL VEHICLE

444-0026

1. If +24 VDC is not obtained, troubleshoot electrical system (WP 0005).
2. IF +24 VDC is obtained, replace electric fuel pump (WP 0059).

- b. If fuel is not pumped out of disconnected fuel line, remove lines and fittings between fuel tank and fuel filter head and clean/replace lines, in-line fuel filter, and/or fuel strainer (WP 0005).
- c. If fuel is pumped out of line, reconnect line and proceed to step 8.

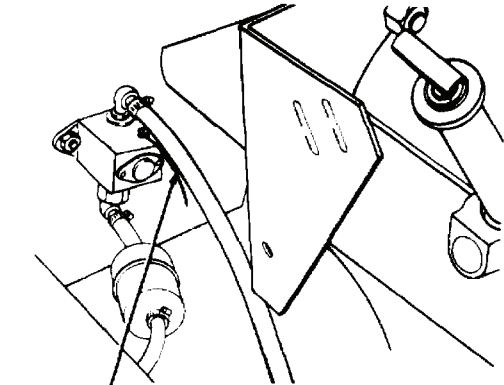

DISCONNECT WIRE

ORIGINAL VEHICLE

444-0027

Step 8. Operate engine for 15 minutes at idle speed.

- a. Carefully and slowly remove radiator cap.
- b. Check coolant temperature using a thermometer; be sure thermometer does not touch any metal parts of radiator.
- c. Coolant temperature should be 175 to 200°F (79 to 93°C).
  1. If coolant temperature is not between 175 to 200°F (79 to 93°C), remove and test thermostat (WP 0084).
  2. If coolant temperature is 175 to 200°F (79 to 93°C), proceed to step 9.

---

**MALFUNCTION**  
**TEST OR INSPECTION**  
**CORRECTIVE ACTION**

---

**5. ENGINE STALLS FREQUENTLY OR DOES NOT DEVELOP FULL POWER (CONTINUED).**

- Step 9. Check for correct adjustment of accelerator/throttle control (WP 0074 for original vehicle or WP 0075 for replacement vehicle).
- If adjustment of accelerator/throttle control is not correct, adjust (WP 0074 or WP 0075).
  - If accelerator/throttle control adjustment is okay, proceed to step 10.
- Step 10. Remove drive belt from engine water pump (WP 0088 for original vehicle or WP 0089 for replacement vehicle).
- Start engine and operate at idle speed for 5 minutes maximum.
  - Check if engine power increases.
  - If engine power increases, replace water pump (WP 0086 for original vehicle or WP 0087 for replacement vehicle) and reinstall drive belt on water pump.

**6. ENGINE CRANKS BUT DOES NOT START WHEN QUICK START IS ACTIVATED.**

- Step 1. Ensure quick start cylinder is hand tight.
- If cylinder is not hand tight, tighten.
  - If cylinder is hand tight, proceed to step 2.
- Step 2. Check ether supply; press lever against valve and listen for hissing.
- If hissing sound is not heard, replace empty cylinder (WP 0073).
  - If hissing sound is heard, proceed to step 3.
- Step 3. Check tubing for leaks or damage; listen for hissing sound when lever is pressed against valve.
- If hissing sound is heard, replace tubing (WP 0073).
  - If hissing sound is not heard, proceed to step 4.
- Step 4. Check valve for damage.  
Replace valve (WP 0073).

---

<b>MALFUNCTION</b>
<b>TEST OR INSPECTION</b>
<b>CORRECTIVE ACTION</b>

---

**7. EXCESSIVE OIL CONSUMPTION.**

- Step 1. Check for engine oil leaks at cylinder head cover gasket, oil pan gasket, timing gear cover gasket, engine oil filter, and oil drain plug gasket.
- If oil leaks are observed by engine oil filter and oil drain plug, tighten oil filter and replace oil drain plug gasket (WP 0049 for original vehicle or WP 0050 for replacement vehicle). If leaks are observed at other areas, notify Direct Support Maintenance.
  - If oil leaks are not observed, proceed to step 2.
- Step 2. Check if too light an engine oil was used.
- If engine oil is too light, drain engine oil and replace engine oil filter (WP 0049 for original vehicle or WP 0050 for replacement vehicle). Refer to LO 10-3930-638-12 for correct weight engine oil.
  - If engine oil is okay, proceed to step 3.
- Step 3. With engine operating, check oil pressure gage for excessively high pressure indication (normal oil pressure indication is 50 to 70 PSI (343 to 483 kPa).
- If oil pressure gage indication is excessively high, notify Direct Support Maintenance.

**8. LOW ENGINE OIL PRESSURE.**

- Step 1. Check for engine oil leaks at engine oil filter and oil pan drain plug.
- If leaks are observed, tighten oil filter; replace oil pan drain plug gasket.
  - If no leaks are observed, proceed to step 2.
- Step 2. Check engine oil for dirty condition. Remove dipstick, wipe it between thumb and forefinger, and note if oil feels gritty and looks dirty.
- If oil feels gritty and looks dirty, drain engine oil and replace engine oil filter (WP 0049 original vehicle or WP 0050 for replacement vehicle). Refer to LO 10-3930-638-12 for correct weight oil.
  - If engine oil is not dirty, proceed to step 3.
- Step 3. Check if too light an engine oil was used.
- If engine oil is too light, drain engine oil and replace engine oil filter (WP 0049 for original vehicle or WP 0050 for replacement vehicle). Refer to LO 10-3930-638-12 for correct weight oil.
  - If engine oil is not too light, proceed to step 4.
- Step 4. Check if oil pressure indicator light is illuminated when oil pressure gage indicates low oil pressure.
- If oil pressure indicator is illuminated, notify Direct Support Maintenance.
  - If oil pressure indicator is not illuminated, refer to gages troubleshooting (WP 0027).
- Step 5. Check if oil pressure gage indicates normal oil pressure when oil pressure indicator is illuminated.
- If oil pressure gage indicates normal oil pressure, troubleshoot electrical system (WP 0005).
  - If oil pressure gage indicates low oil pressure, notify Direct Support Maintenance.

---

**MALFUNCTION**  
**TEST OR INSPECTION**  
**CORRECTIVE ACTION**

---

**8. LOW ENGINE OIL PRESSURE (CONTINUED).**

- Step 1. Check for engine oil leaks at engine oil filter and oil pan drain plug.
- If leaks are observed, tighten oil filter; replace oil pan drain plug gasket.
  - If no leaks are observed, proceed to step 2.
- Step 2. Check engine oil for dirty condition. Remove dipstick, wipe it between thumb and forefinger, and note if oil feels gritty and looks dirty.
- If oil feels gritty and looks dirty, drain engine oil and replace engine oil filter (WP 0049 original vehicle or WP 0050 for replacement vehicle). Refer to LO 10-3930-638-12 for correct weight oil.
  - If engine oil is not dirty, proceed to step 4.
- Step 3. Check if too light an engine oil was used.
- If engine oil is too light, drain engine oil and replace engine oil filter (WP 0049 for original vehicle or WP 0050 for replacement vehicle). Refer to LO 10-3930-638-12 for correct weight oil.
  - If engine oil is not too light, proceed to step 4.
- Step 4. Check if oil pressure indicator light is illuminated when oil pressure gage indicates low oil pressure.
- If oil pressure indicator is illuminated, notify Direct Support Maintenance.
  - If oil pressure indicator is not illuminated, refer to gages troubleshooting (WP 0027).
- Step 5. Check if oil pressure gage indicates normal oil pressure when oil pressure indicator is illuminated.
- If oil pressure gage indicates normal oil pressure, troubleshoot electrical system (WP 0005).
  - If oil pressure gage indicates low oil pressure, notify Direct Support Maintenance.

**9. ENGINE WILL NOT SHUT DOWN.**

Place ignition switch in OFF position. Disconnect wire at fuel injection pump terminal (original vehicle).

- If engine stops, replace ignition switch.
- If engine does not stop, place fuel shut-off valve in OFF position and replace fuel injection pump (notify Direct Support Maintenance).

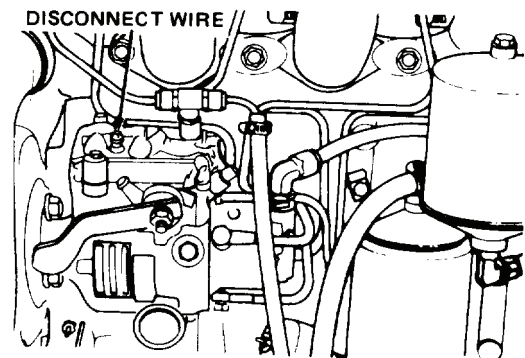

TA126861

**END OF WORK PACKAGE**

# ORGANIZATIONAL TROUBLESHOOTING PROCEDURES

## FUEL SYSTEM TROUBLESHOOTING

MALFUNCTION	TEST OR INSPECTION	CORRECTIVE ACTION
-------------	--------------------	-------------------

### 1. LOW FUEL PRESSURE.

- Step 1. Check for air in fuel system (original vehicle).
- Place ignition switch in ON position. Open bleed valve plug on top of secondary fuel filter allowing air to bleed out of both filters. When fuel, free of bubbles, starts to flow, close bleed valve plug and wipe parts free of fuel. Turn ignition switch OFF.
  - If no air in fuel system, proceed to step 2.

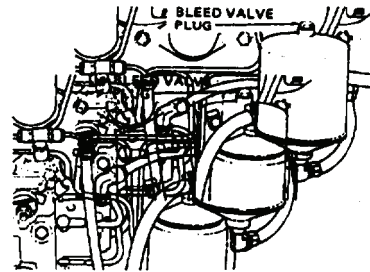

TA126858

- Step 2. Check if fuel shut-off valve is in OFF position (original vehicle).
- If in OFF position, place in full ON position as shown.
  - If in ON position, proceed to step 3.

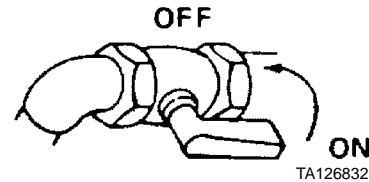

TA126832

- Step 3. Check for leaks at fittings between fuel tank and fuel injection pump.
- If leaks are observed, tighten or replace fittings (WP 0065 for original vehicle or WP 0066 for replacement vehicle).
  - If leaks are not observed, proceed to step 4.
- Step 4. Check fuel tank strainer, in-line fuel filter, and/or lines for clogged condition (WP 0065, WP 0067, WP 0070 for original vehicle or WP 0066, WP 0068, and WP 0071 for replacement vehicle).
- If strainer, fuel filter and/or lines are clogged, replace part (WP 0065, WP 0067, WP 0070 for original vehicle or WP 0066, WP 0068, and WP 0071 for replacement vehicle).
  - If strainer, fuel filter, and lines are okay, proceed to step 5.

---

**MALFUNCTION**  
**TEST OR INSPECTION**  
**CORRECTIVE ACTION**

---

**1. LOW FUEL PRESSURE (CONTINUED).**

- Step 5. Check for clogged fuel filters by disconnecting line between fuel filter head and fuel injection pump at fuel injection pump.
- a. Place ignition switch in ON position and crank engine.
  - b. Fuel should be pumped out of disconnected line.
    1. If fuel is not pumped out of disconnected line, reconnect fuel line and service fuel filters (WP 0067 and WP 0069 for original vehicle or WP 0068 and WP 0072 for replacement vehicle).
    2. If fuel is pumped out of disconnected line, reconnect fuel line and proceed to step 6.
- Step 6. Disconnect fuel line at fuel filter head and connect to a tee fitting.
- a. Connect a hose between other end of tee fitting and fuel filter head.
  - b. Connect pressure gage to tee fitting.
  - c. Place IGNITION switch in ON position.
  - d. Pressure gage should indicate 4.5 to 6 PSI (31 to 41 kPa).

If pressure gage does not indicate 4.5 to 6 PSI, replace electric fuel pump (WP 0059 for original vehicle or WP 0060 for replacement vehicle).

**NOTE**

If fuel injection pump is suspected to be cause of problem, perform WP 0057 for original vehicle or WP 0058 for replacement vehicle.

**2. EXCESSIVE FUEL USAGE.**

- Step 1. Check fuel lines for leakage or damage.
- a. If fuel lines are leaking or damaged, repair or replace (WP 0065 for original vehicle or WP 0066 for replacement vehicle).
  - b. If fuel lines are okay, proceed to step 2.
- Step 2. Check fuel tank for leakage or damage.
- a. If fuel tank leaks or is damaged, notify Direct Support Maintenance.
  - b. If fuel tank is okay, proceed to step 3.



---

**MALFUNCTION**  
**TEST OR INSPECTION**  
**CORRECTIVE ACTION**

---

**2. EXCESSIVE FUEL USAGE (CONTINUED).**

If NBC exposure is suspected, all air filter media should be handled by personnel wearing protective equipment. Consult your unit NBC officer or NBC NCO for appropriate handling or disposal procedures.

Step 3. Check if air cleaner indicator red flag is in view.

- a. If in view, depress reset button on top of indicator and ensure red flag disappears from view. (If red flag does not disappear from view, replace air cleaner indicator as described in WP 0061 for original vehicle or WP 0062 for replacement vehicle). Crank engine and check if red flag is in view; if red flag is in view, service air cleaner (WP 0062).
- b. If red flag is not in view, notify Direct Support Maintenance.

**END OF WORK PACKAGE**



---

## ORGANIZATIONAL TROUBLESHOOTING PROCEDURES

### EXHAUST SYSTEM TROUBLESHOOTING

---

MALFUNCTION
TEST OR INSPECTION
CORRECTIVE ACTION
<p><b>1. Excessive Exhaust Noise.</b></p> <p>Step 1. Check muffler and exhaust pipe for cracks and holes.</p> <p style="padding-left: 20px;">a. If muffler or exhaust pipe are cracked or holes are observed, replace (WP 0076 for original vehicle or WP 0077 for replacement vehicle).</p> <p style="padding-left: 20px;">b. If muffler and exhaust pipe check okay, proceed to step 2.</p> <p>Step 2. Squirt small amount of oil on muffler gasket area where muffler connects to exhaust manifold. With engine idling, check if air bubbles can be seen, indicating damaged gasket.</p> <p style="padding-left: 20px;">a. If air bubbles are seen, replace gasket (WP 0076 for original vehicle or WP 0077 for replacement vehicle).</p> <p style="padding-left: 20px;">b. If air bubbles are not seen, proceed to step 3.</p> <p>Step 3. Squirt small amount of oil on exhaust manifold in gasket area where exhaust manifold is mounted on cylinder head. When engine idling, check if air bubbles can be seen, indicating damaged gasket.</p> <p style="padding-left: 20px;">a. If air bubbles are seen, replace gasket (WP 0055 for original vehicle or WP 0056 for replacement vehicle).</p> <p style="padding-left: 20px;">b. If muffler and exhaust pipe check okay, proceed to step 4.</p> <p>Step 4. Check exhaust manifold for cracks or holes.</p> <p style="padding-left: 20px;">Replace exhaust manifold (WP 0055 for original vehicle or WP 0056 for replacement vehicle).</p> <p><b>2. EXCESSIVE EXHAUST SMOKE.</b></p> <p>Check if muffler requires cleaning.</p> <p style="padding-left: 20px;">a. Clean (WP 0076 for original vehicle or WP 0077 for replacement vehicle).</p> <p style="padding-left: 20px;">b. If problem is not corrected, notify Direct Support Maintenance.</p>

**END OF WORK PACKAGE**



---

# ORGANIZATIONAL TROUBLESHOOTING PROCEDURES

## COOLING SYSTEM TROUBLESHOOTING

---

### MALFUNCTION

### TEST OR INSPECTION

### CORRECTIVE ACTION

---

#### 1. Engine Overheats.

- Step 1. Check fan belt for proper tension (original vehicle).
- a. Depress fan belt midway between fan pulley and crankshaft pulley.
  - b. Fan belt should be deflected approximately 1/2 in.
    1. If fan belt does not deflect approximately 1/2 in. (1.3 cm), adjust it (WP 0088).
    2. If fan belt deflects approximately 1/2 in. (1.3 cm) proceed to step 2.
- Step 2. Inspect fan belt for damage, wear, oil covered condition, or riding deeply in pulley groove.
- a. If any of the above conditions are observed, replace fan belt (WP 0088 for original vehicle or WP 0089 for replacement vehicle).
  - b. If none of the above conditions are observed, proceed to step 3.
- Step 3. Check radiator and hoses for leakage or damage.
- a. If radiator and/or hoses are leaking or damaged, replace (WP 0080 and WP 0082 for original vehicle or WP 0081 and WP 0083 for replacement vehicle).
  - b. If radiator and hoses are okay, proceed to step 4.
- Step 4. With engine idling, remove radiator cap and observe coolant to see if it moves indicating water pump is operating.
- a. If coolant movement is not observed, replace water pump (WP 0086 for original vehicle or WP 0087 for replacement vehicle).
  - b. If coolant movement is observed, proceed to step 5.
- Step 5. Check fan blade assembly for damage.
- a. If fan blade assembly is damaged, replace (WP 0088 for original vehicle or WP 0089 for replacement vehicle).
  - b. If fan blade assembly checks okay, proceed to step 6.
- Step 6. Check thermostat (WP 0084 for original vehicle or WP 0085 for original vehicle).  
Replace thermostat (WP 0084 or WP 0085).

#### 2. ENGINE DOES NOT REACH OPERATING TEMPERATURE.

Check thermostat (WP 0085 for original vehicle or WP 0085 for replacement vehicle).

Replace thermostat (WP 0085 or WP 0085).

---

**MALFUNCTION**  
**TEST OR INSPECTION**  
**CORRECTIVE ACTION**

---

**3. COOLING SYSTEM NOT PRESSURIZED.**

**NOTE**

With engine at normal operating temperature, run engine at high speed for 2 minutes and return to idle speed. Carefully cover radiator cap with a rag and rotate counterclockwise to first detent. A hissing noise from cap and filler neck indicates that system is pressurized.

- Step 1. Allow engine to cool and remove radiator cap (WP 0078 for original vehicle or WP 0079 for replacement vehicle).

**NOTE**

It may be necessary to reinstall radiator cap several times to ensure tight seal.

- a. Operate pressure tester pump and observe meter reading at its highest point.
- b. Cap release pressure should be 6 to 9 lb, and should remain steady for at least 30 seconds.
  1. If radiator cap pressure is 6 to 9 lb, and remains steady for at least 30 seconds before dropping, proceed to step 2.
  2. If radiator cap pressure is not 6 to 9 lb, or if pressure drops rapidly, replace radiator cap.

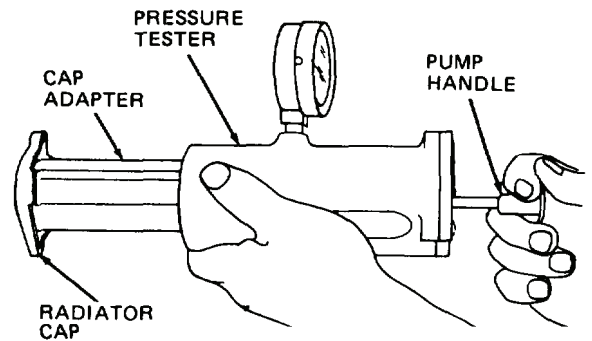

TA126864

- Step 2. Disconnect cap adapter from pressure tester.
- a. Attach pressure tester to radiator filler neck, with locking ears stopped by stop lugs on radiator filler neck.
  - b. Press down on tester and rotate clockwise until locking ears are stopped by stop lugs on radiator filler neck.
  - c. Clamp radiator inlet and outlet hoses, or block hose flanges.
  - d. Operate pressure test pump until meter indicates 9 lb pressure, and observe meter.
    1. If pressure drops quickly, radiator has serious leakage. Replace radiator (WP 0082 for original vehicle or WP 0083 for replacement vehicle).
    2. If pressure holds steady for two or more minutes, radiator check is satisfactory.
    3. If pressure drops slowly, radiator has seepage or slight leakage. Replace radiator (WP 0082 or WP 0083).

**END OF WORK PACKAGE**

# ORGANIZATIONAL TROUBLESHOOTING PROCEDURES

## BATTERY SYSTEM TROUBLESHOOTING (MODEL 207)

MALFUNCTION	TEST OR INSPECTION	CORRECTIVE ACTION
-------------	--------------------	-------------------

### 1. ALL ELECTRICAL SYSTEMS ARE WEAK.

- Step 1. Connect voltmeter leads to connectors of negative battery cable at battery post and starter ground.  
 Note voltmeter indication while an assistant cranks engine.
- If voltmeter indicates less than 0.5 VDC, proceed to step 2.
  - If voltmeter indicates more than 0.5 VDC, replace the negative battery cable (WP 0133).
- Step 2. Connect voltmeter leads to connectors of positive battery cable at battery post and starter B terminal.  
 Note voltmeter indication while an assistant cranks engine.
- If voltmeter indicates less than 0.5 VDC, proceed to step 3.
  - If voltmeter indicates more than 0.5 VDC, replace positive battery cable (WP 0133).
- Step 3. Connect voltmeter leads to positive and negative posts of one battery.
- Note voltmeter indication while an assistant cranks engine.
  - Repeat for remaining battery.
  - If voltmeter indicates less than 9.5 VDC, check specific gravity of each battery cell. If there is more than 25 points variation (0.025) between individual cells, replace battery (WP 0133).

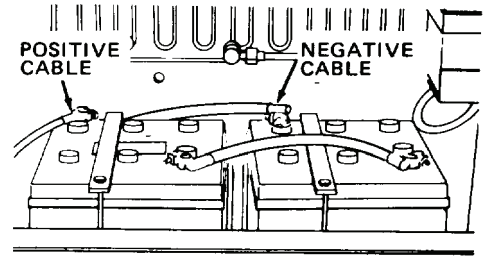

TA126894

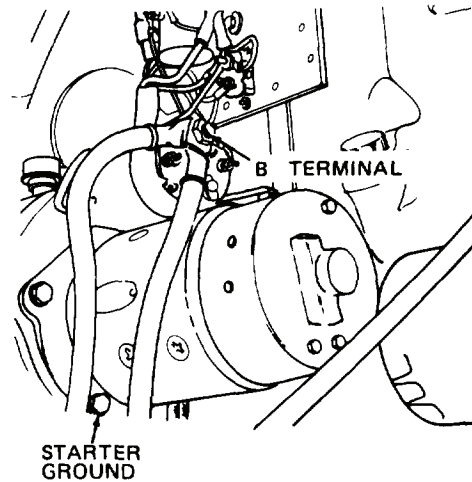

TA126895

---

**MALFUNCTION**  
**TEST OR INSPECTION**  
**CORRECTIVE ACTION**

---

**2. BATTERIES ARE HOT OR USE EXCESSIVE WATER.**

Step 1. Connect voltmeter leads to alternator BAT terminal and case (ground).

Step 2. With all accessories turned off, operate engine at 1,800 RPM and note voltmeter indication.

If voltmeter indicates more than 31 VDC, replace alternator (WP 0093).

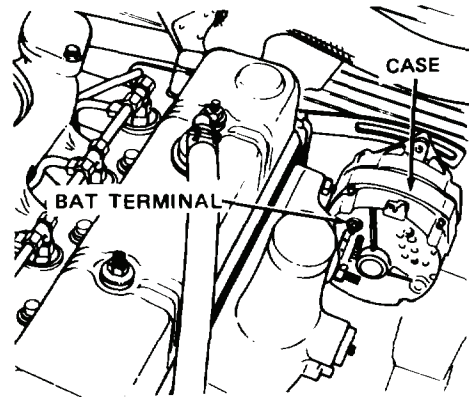

TA126896

**END OF WORK PACKAGE**



## ORGANIZATIONAL TROUBLESHOOTING PROCEDURES

### BATTERY SYSTEM TROUBLESHOOTING (MODEL 4-390)

---

#### MALFUNCTION

#### TEST OR INSPECTION

#### CORRECTIVE ACTION

---

#### 1. ALL ELECTRICAL SYSTEMS ARE WEAK.

- Step 1. Connect voltmeter leads to connectors of negative battery cable at battery post and starter ground. Note voltmeter indication while assistant cranks engine.
- a. If voltmeter indicates less than 0.5 VDC, proceed to step 2.
  - b. If voltmeter indicates more than 0.5 VDC, replace negative battery cable (WP 0134).

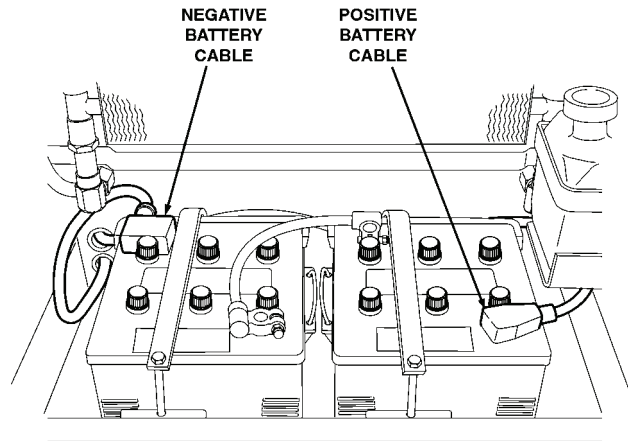

444-0086

- Step 2. Connect voltmeter leads to connectors of positive battery cable at battery post and starter B terminal. Note voltmeter indication while an assistant cranks engine.
- a. If voltmeter indicates less than 0.5 VDC, proceed to step 3.
  - b. If voltmeter indicates more than 0.5 VDC, replace the positive battery cable (WP 0134).

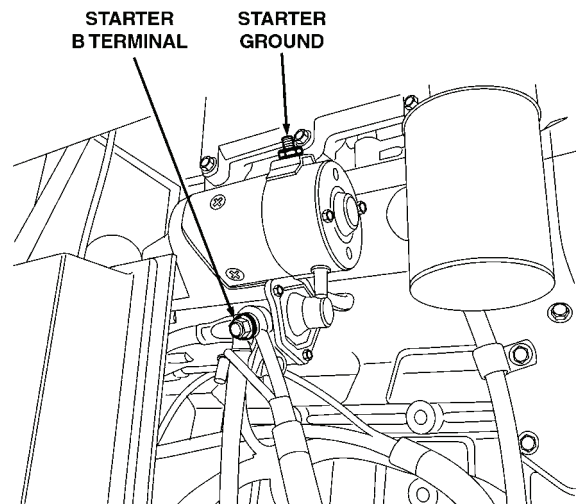

444-0087

---

**MALFUNCTION**  
**TEST OR INSPECTION**  
**CORRECTIVE ACTION**

---

**1. ALL ELECTRICAL SYSTEMS ARE WEAK (CONTINUED).**

Step 3. Connect voltmeter leads to positive and negative posts of one battery.

Note voltmeter indication while an assistant cranks engine.

Repeat for remaining battery.

If voltmeter indicates less than 9.6 VDC, check specific gravity of each battery cell. If there is more than 25 points variation (0.025) between individual cells, replace battery (WP 0134).

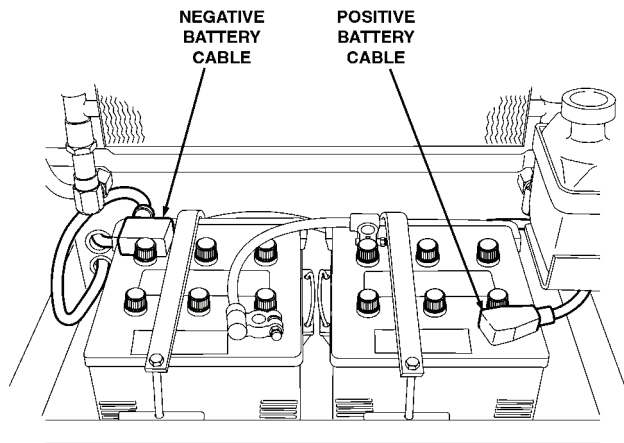

444-0086

**2. BATTERIES ARE HOT OR USE EXCESSIVE WATER.**

Connect voltmeter leads to alternator BAT terminal and case (ground).

With all accessories turned OFF, operate engine at 1,800 RPM and note voltmeter indication.

If voltmeter indicates more than 31 VDC, replace alternator (WP 0094).

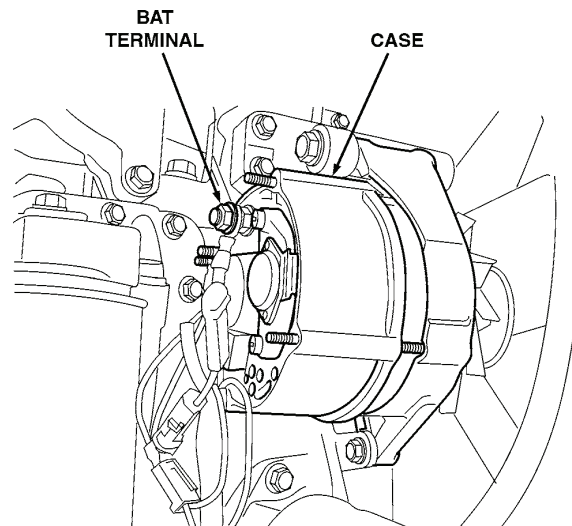

444-0088

**END OF WORK PACKAGE**

# ORGANIZATIONAL TROUBLESHOOTING PROCEDURES

## STARTING SYSTEM TROUBLESHOOTING (MODEL 207)

MALFUNCTION	TEST OR INSPECTION	CORRECTIVE ACTION
-------------	--------------------	-------------------

### 1. STARTER CRANKS TOO SLOWLY.

Step 1. Connect positive voltmeter lead to solenoid B terminal and negative voltmeter lead to solenoid M terminal.

Note voltmeter indication while assistant cranks engine.

- a. If voltmeter indicates less than 0.3 VDC, proceed to step 2.
- b. If voltmeter indicates more than 0.3 VDC, replace starter assembly (WP 0095).

Step 2. Remove starter assembly from engine (WP 0095).

Connect no-load test setup to starter as shown, and adjust carbon pile for 20 VDC indication on voltmeter.

- a. If ammeter indicates 52 to 90 amperes and RPM indicator indicates 8,000 to 13,000 RPM, disconnect starter from test setup and reinstall on engine (WP 0095).
- b. If ammeter does not indicate 52 to 90 amperes, or RPM indicator does not indicate 8000 to 13,000 RPM, record voltage, current and RPM, and replace starter assembly (WP 0095). Forward test results to Direct Support Maintenance with defective starter.

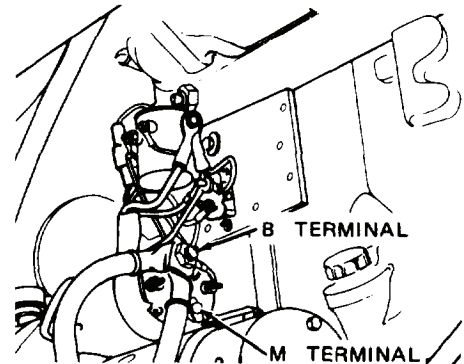

TA128697

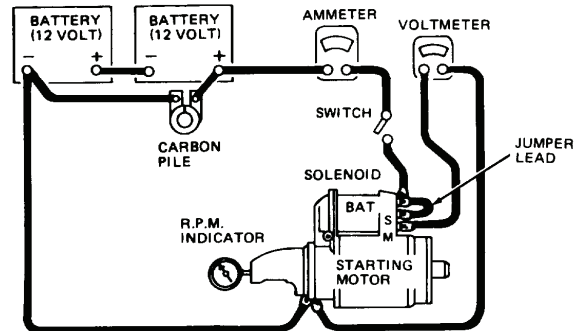

TA128698

**MALFUNCTION**  
**TEST OR INSPECTION**  
**CORRECTIVE ACTION**

**2. STARTER FAILS TO CRANK.**

Step 1. Connect voltmeter leads to S terminal of starter solenoid and ground.

Note voltmeter indication while an assistant depresses start switch.

- a. If voltmeter indicates 24 VDC, replace starter assembly (WP 0095).
- b. If voltmeter indicates less than 24 VDC, or zero, proceed to step 2.

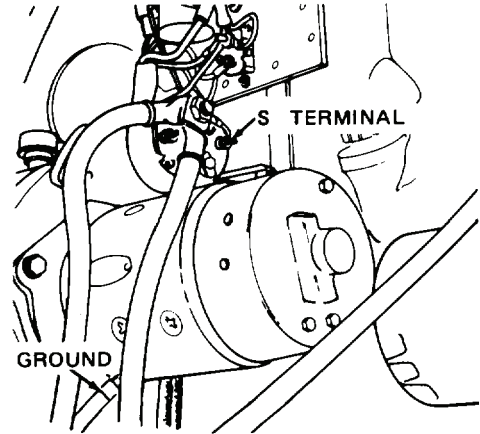

TA128699

Step 2. Connect voltmeter leads to center terminal of starter relay and ground.

Note voltmeter indication while an assistant depresses start switch.

- a. If voltmeter indicates 24 VDC, replace starter relay (WP 0096).
- b. If voltmeter indicates zero Volts, proceed to step 3.

Step 3. Connect voltmeter leads to terminals of neutral start switch.

Note voltmeter indication while an assistant depresses start switch.

- a. If voltmeter indication is a constant 24 VDC, replace neutral start switch (WP 0118).
- b. If voltmeter indication is a constant zero Volts, proceed to step 4.

Step 4. Tag and disconnect wires from lockout relay located at bottom center of instrument panel.

Connect ohmmeter leads to B and H terminals of lockout relay.

- a. If ohmmeter indicates more than 0.1 Ohm, replace lockout relay (WP 0107).
- b. If ohmmeter indicates less than 0.1 Ohm, reconnect wires to lockout relay and proceed to step 5.

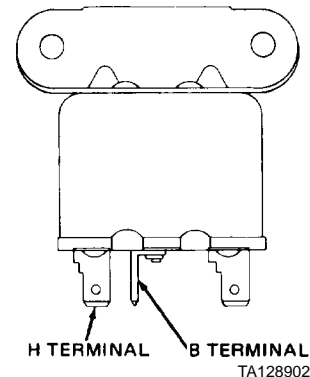

TA128902

---

MALFUNCTION	TEST OR INSPECTION	CORRECTIVE ACTION
-------------	--------------------	-------------------

---

## 2. STARTER FAILS TO CRANK (CONTINUED).

- Step 5. Connect voltmeter leads to IGN and GRD terminals of ignition switch. With ignition switch set to ON, voltmeter should indicate 24 VDC.
- If voltmeter does not indicate 24 VDC, proceed to step 6.
  - If voltmeter indicates 24 VDC, proceed to step 7.
- Step 6. Turn ignition switch to OFF and remove key. Connect ohmmeter leads to terminals of 25 ampere circuit breaker and note ohmmeter indication.
- If ohmmeter indicates more than 0.1 Ohm, replace 25 ampere circuit breaker (WP 0097).
- Step 7. Tag and disconnect wires from start switch located at left of steering column. Connect ohmmeter leads to terminals of start switch, and note ohmmeter indication while depressing start switch.
- If ohmmeter indicates more than 0.1 Ohm, replace start switch (WP 0105).

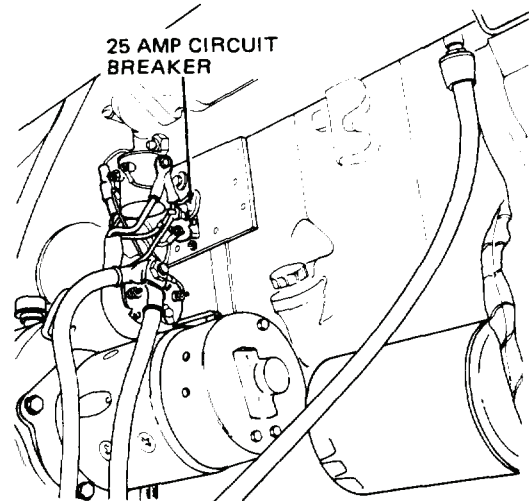

TA128903

## 3. STARTER CRANKS CONTINUOUSLY.

- Step 1. Connect voltmeter leads to S terminal of starter solenoid and ground, and turn ignition switch to ON.
- If voltmeter indicates zero Volts, replace starter assembly (WP 0095).
  - If voltmeter indicates 24 VDC, proceed to step 2.
- Step 2. Connect voltmeter leads to terminal 1 of starter relay and ground, and turn ignition switch to ON.
- If voltmeter indicates 24 VDC, replace start switch (WP 0105).
  - If voltmeter does not indicate 24 VDC, replace starter relay (WP 0097).



---

## ORGANIZATIONAL TROUBLESHOOTING PROCEDURES

### STARTING SYSTEM TROUBLESHOOTING (MODEL 4-390)

---

MALFUNCTION
TEST OR INSPECTION
CORRECTIVE ACTION
<p><b>1. STARTER FAILS TO CRANK.</b></p> <p>Step 1. Ensure direction selection lever is in N (Neutral) position (TM 10-3930-638-10).</p> <p>Step 2. Use multimeter to check battery voltage. Voltage should be 24 VDC. Charge batteries if voltage is less than 24 VDC. Replace batteries if batteries will not take and hold a charge (WP 0134).</p> <p>Step 3. Check for loose or corroded battery cable connections. Clean and tighten connections. Replace battery cables if defective (WP 0134).</p> <p>Step 4. Connect multimeter leads to terminal of ignition switch. If no continuity when ignition switch is ON, replace ignition switch (WP 0106).</p> <p>Step 5. Connect multimeter leads to terminals of start switch. If no continuity when start switch is pressed, replace start switch (WP 0105).</p> <p>Step 6. Connect multimeter leads to terminals of neutral start switch. If no continuity when direction selector lever is in N (Neutral) position, replace neutral start switch (WP 0134).</p> <p>Step 7. Connect multimeter leads to terminals of starter relay. If no continuity when starter relay is activated, replace starter relay (WP 0106).</p> <p><b>2. STARTER CRANKS TOO SLOWLY.</b></p> <p>Step 1. Use multimeter to check battery voltage. Voltage should be 24 VDC. Charge batteries if voltage is less than 24 VDC. Replace batteries if batteries will not take and hold a charge (WP 0134).</p> <p>Step 2. Check for loose or corroded battery cable connections. Clean and tighten connections. Replace battery cables if defective (WP 0134).</p>





**END OF WORK PACKAGE**





## ORGANIZATIONAL TROUBLESHOOTING PROCEDURES

### CHARGING SYSTEM TROUBLESHOOTING (MODEL 207)

#### MALFUNCTION

#### TEST OR INSPECTION

#### CORRECTIVE ACTION

#### 1. ABNORMAL ALTERNATOR LIGHT OPERATION.

Step 1. Place ignition switch in OFF position.

Alternator light should be off.

- a. If alternator light is off, proceed to step 2.
- b. If alternator light is on, grasp and pull connector from alternator terminals 1 and 2. If the alternator light goes out, replace the alternator (WP 0093).

If alternator light stays on, check for a short between these wires, then install connector on alternator terminals 1 and 2.

Step 2. Place ignition switch in ON position with engine stopped. Alternator light should be on. With engine running, alternator light should be off.

- a. If alternator light is off with engine stopped, or on with engine running, check for an open circuit between alternator terminal 1 and alternator light. Use an ohmmeter to check diode and 40 Ohm resistor in alternator light circuit.
- b. If circuit tests are satisfactory, troubleshoot alternator (MALFUNCTION 2 in this work package).

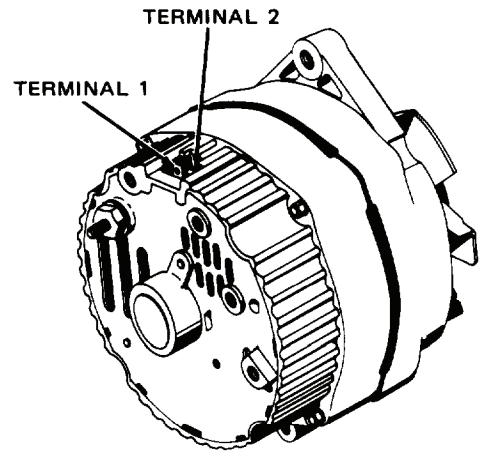

TA126904

---

**MALFUNCTION**  
**TEST OR INSPECTION**  
**CORRECTIVE ACTION**

---

**2. ALTERNATOR OUTPUT LOW, UNSTEADY, OR ZERO.**

- Step 1. Turn ignition switch to ON position and alternately connect voltmeter leads from ground to alternator terminal 1, terminal 2, and B terminal.
- If voltmeter indicates 24 VDC at all three terminals, proceed to step 2.
  - If voltmeter does not indicate 24 VDC at one or more terminals, check for an open circuit between battery positive post and affected alternator terminal.

- Step 2. Disconnect battery ground cable and connect an ammeter between alternator B terminal and starter relay terminal 3.

Reconnect battery ground cable, and connect a carbon pile across batteries. Turn all vehicle lights on to increase load on batteries, and operate engine at 1,800 RPM.

- If ammeter indicates 27 to 47 amperes, but alternator light stays on, check for open circuit from alternator terminal 1 in wiring, diode, and 40 Ohm resistor.
- If ammeter does not indicate 27 to 47 amperes, replace alternator (WP 0093).

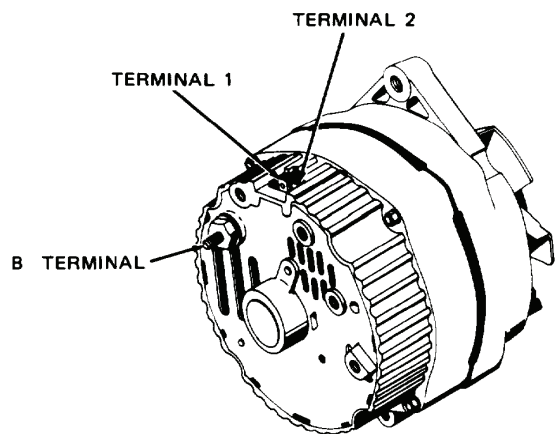

TA126905

**END OF WORK PACKAGE**

---

## ORGANIZATIONAL TROUBLESHOOTING PROCEDURES

### CHARGING SYSTEM TROUBLESHOOTING (MODEL 4-390)

---

MALFUNCTION
-------------

---

TEST OR INSPECTION
--------------------

CORRECTIVE ACTION
-------------------

---

**1. INSTRUMENT PANEL LIGHT FOR ALTERNATOR COMES ON WHEN ENGINE IS RUNNING.**

Step 1. Check for loose or corroded wire connections to alternator. Clean and tighten connections. Replace terminals and connectors of rear wiring harness if defective (WP 0138).

Step 2. Check for loose or corroded battery cable connections. Clean and tighten connections. Replace battery cables if defective (WP 0134).

**2. ALTERNATOR OUTPUT LOW, UNSTEADY, OR ZERO.**

Step 1. Test alternator (WP 0034).

Step 2. Replace alternator if testing indicates alternator if defective (WP 0094).

**END OF WORK PACKAGE**



# ORGANIZATIONAL TROUBLESHOOTING PROCEDURES

## HORN AND BACK-UP ALARM SYSTEM TROUBLESHOOTING

MALFUNCTION	TEST OR INSPECTION	CORRECTIVE ACTION
-------------	--------------------	-------------------

### 1. HORN DOES NOT SOUND.

- Step 1. Disconnect positive wire from side of horn. Connect positive voltmeter lead to connector on positive wire, and negative voltmeter lead to vehicle ground.
- If voltmeter indicates 24 VDC, reconnect positive wire to side of horn and proceed to step 2.
  - If voltmeter does not indicate 24 VDC, troubleshoot 25 ampere circuit breaker (WP 0012, MALFUNCTION 2, step 6). If 25 ampere circuit breaker test is satisfactory, check for open circuit in wiring between battery positive post and connector on horn positive wire.

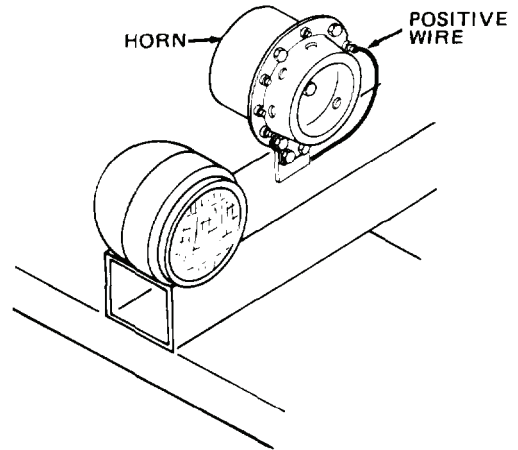

TA126906

- Step 2. Disconnect horn button wire from bottom of horn. Temporarily connect jumper wire from terminal on bottom of horn to vehicle ground.
- If horn sounds, reconnect horn button wire to bottom of horn and proceed to step 3.
  - If horn does not sound, replace horn (WP 0127).

- Step 3. Disconnect horn button wire from terminal on steering column. Temporarily connect jumper wire from connector on horn button wire to vehicle ground.
- If horn does not sound, check for open circuit in wire between steering column and horn.
  - If horn sounds, replace horn switch (WP 0129).

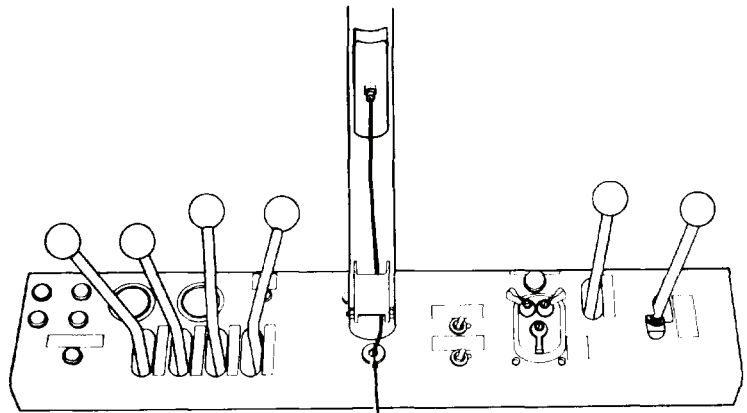

TA126907

---

**MALFUNCTION**  
**TEST OR INSPECTION**  
**CORRECTIVE ACTION**

---

**2. BACK-UP ALARM DOES NOT SOUND.**

- Step 1. Turn ignition switch to ON position and temporarily connect a jumper wire to terminals of back-up alarm switch.
- If back-up alarm sounds, replace back-up alarm switch (WP 0118).
  - If back-up alarm does not sound, proceed to step 2.
- Step 2. Disconnect wire from positive terminals of back-up alarm.
- Temporarily connect a jumper wire between positive battery cable and positive terminal of back-up alarm.
- If back-up alarm sounds, reconnect wire to positive alarm terminal and proceed to step 3.
  - If back-up alarm does not sound, connect a jumper wire to vehicle ground and back-up alarm negative terminal. If alarm does not sound with ground jumper at negative terminal and battery positive jumper at positive terminal, replace back-up alarm (WP 0130).
- Step 3. Turn and hold ignition switch at LAMP TEST position.
- If at least one warning indicator (transmission temperature, hydraulic filter, or engine temperature) is on, check for open circuit in wiring between back-up alarm, back-up alarm switch, and 6 ampere circuit breaker.
  - If at least one warning indicator is not on, turn ignition switch to ON position and check if a slight buzz can be heard at electric fuel pump. If slight buzz indicating electric fuel pump operation is not heard, troubleshoot ignition switch (WP 0018).

**NOTE**

If floodlights, taillights, stop lights, and gage lights are all inoperative, turn ignition switch to OFF position. Connect positive voltmeter lead to terminal F of vehicle lights switch cable connector and negative voltmeter lead to vehicle ground. If voltmeter does not indicate 24 VDC with ignition switch set at ON position, check for open circuit in wiring between terminal F of cable connector and ignition switch. If wiring check is satisfactory, replace ignition switch (WP 0106).

**END OF WORK PACKAGE**

# ORGANIZATIONAL TROUBLESHOOTING PROCEDURES

## LIGHT SYSTEMS TROUBLESHOOTING

---

<b>MALFUNCTION</b>
<b>TEST OR INSPECTION</b>
<b>CORRECTIVE ACTION</b>

---

### 1. FRONT FLOODLIGHTS INOPERATIVE.

#### NOTE

If one or more front floodlights operates normally, replace bulb in affected floodlight (WP 0111). If floodlight is still inoperative, check for open circuit in wire between inoperative floodlight and front flood switch.

- Step 1. Turn ignition switch to OFF and remove key.
- Disconnect 10 ampere circuit breaker wire from terminal on front flood switch.
  - Connect ohmmeter leads to leads of 10 ampere circuit breaker.
    - If ohmmeter indicates less than 0.1 Ohm, proceed to step 2.
    - If ohmmeter indicates more than 0.1 Ohm, connect ohmmeter leads to vehicle ground and 4-wire terminal of front flood switch. If ohmmeter indicates less than 2 Ohms, check for short in wiring between front flood switch and front floodlights. Replace 10 ampere circuit breaker after short is removed (WP 0104).
- Step 2. Connect ohmmeter leads to terminals of front flood switch and set front flood switch at ON position.
- If ohmmeter indicates less than 0.1 Ohm, reconnect lead of 10 ampere circuit breaker to terminal of front flood switch and proceed to step 3.
  - If ohmmeter indicates more than 0.1 Ohm, replace front flood switch (WP 0104).
- Step 3. Unscrew and remove cable connector from bottom of vehicle lights switch.
- Place main switch lever on vehicle lights switch in SER. DRIVE position.
  - Connect ohmmeter leads to pins F and M of vehicle lights switch.
- If ohmmeter indicates more than 0.1 Ohm, replace vehicle lights switch (WP 0105).

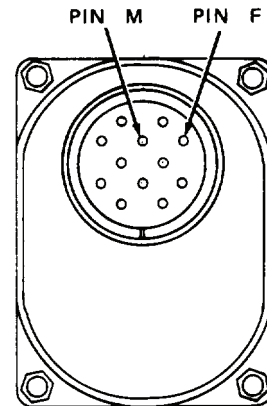

TA126910

---

MALFUNCTION	TEST OR INSPECTION	CORRECTIVE ACTION
-------------	--------------------	-------------------

---

## 2. FRONT BLACKOUT LIGHT INOPERATIVE.

- Step 1. Unplug wire connector from front blackout terminal. Set ignition switch to ON position and place main switch lever on vehicle lights switch in B.O. DRIVE position.

Connect positive voltmeter lead to vehicle ground.

- If voltmeter indicates 24 VDC, place ignition switch and vehicle lights switch in OFF position and place bulb in front blackout light (WP 0113).
- If voltmeter does not indicate 24 VDC, place ignition switch in OFF position, reconnect wire connector to terminal on front blackout light, and proceed to step 2.

- Step 2. Unscrew and remove cable connector from bottom of vehicle lights switch. With main switch lever on vehicle lights switch in B.O. DRIVE position, connect ohmmeter leads to pins D and F of vehicle lights switch.

- If ohmmeter indicates more than 0.1 Ohm, replace vehicle lights switch (WP 0105).
- If ohmmeter indicates less than 0.1 Ohm, check for open circuit in wire between terminal D of cable connector and front blackout light.

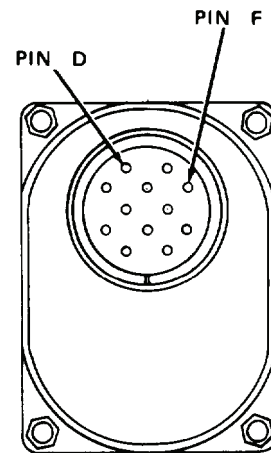

TA126911



**MALFUNCTION**  
**TEST OR INSPECTION**  
**CORRECTIVE ACTION**

**3. BLACKOUT TAILLIGHTS INOPERATIVE.**

**NOTE**

If one blackout taillight operates normally, replace bulb in affected taillight (WP 0114). If taillight is still inoperative, check for open circuit in wire between inoperative taillight and operating taillight.

Unscrew and remove cable connector from bottom of VEHICLE LIGHTS switch.

- a. Place main switch lever on vehicle lights switch in SER. DRIVE position.
- b. Connect ohmmeter leads to pins E and F of vehicle lights switch.
  - 1. If ohmmeter indicates more than 0.1 Ohm, replace vehicle lights switch (WP 0105).
  - 2. If ohmmeter indicates less than 0.1 Ohm, check for open circuit in wire between terminal E of cable connector and blackout taillights.

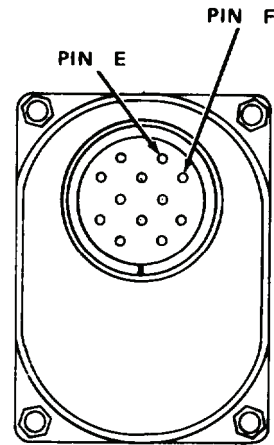

TA126912

**4. SERVICE TAILLIGHTS INOPERATIVE.**

**NOTE**

If one service taillight operates normally, replace bulb in affected taillight (WP 0115). If taillight is still inoperative, check for open circuit in wire between inoperative taillight and operating taillight.

Unscrew and remove cable connector from bottom of VEHICLE LIGHTS switch.

- a. Place main switch lever on vehicle lights switch in SER. DRIVE position.
- b. Connect ohmmeter leads to pins H and F of vehicle lights switch.
  - 1. If ohmmeter indicates more than 0.1 Ohm, replace vehicle lights switch (WP 0105).
  - 2. If ohmmeter indicates less than 0.1 Ohm, check for open circuit in wire between terminal H of cable connector and service taillights.

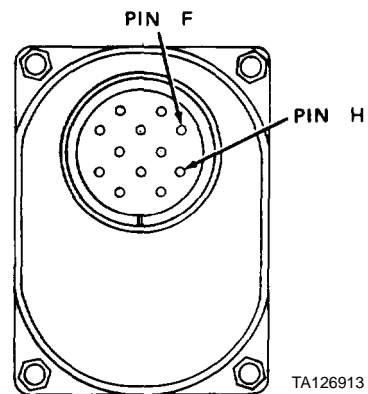

TA126913

---

MALFUNCTION	TEST OR INSPECTION	CORRECTIVE ACTION
-------------	--------------------	-------------------

---

### 5. BLACKOUT STOP LIGHTS INOPERATIVE.

#### NOTE

If one stop light operates normally, replace bulb in affected stop light (WP 0114). If stop light is still inoperative, check for open circuit in wire between inoperative stop light and operating stop light.

Step 1. Place ignition switch in ON position, vehicle lights switch in SER. DRIVE position, and depress brake pedal.

Step 2. Unscrew and remove cable connector from bottom of vehicle lights switch.

Place main switch lever on vehicle lights switch in B.O. MARKER or B.O. DRIVE position.

Connect ohmmeter leads to pins A and F of vehicle lights switch and check for less than 0.1 Ohm, then connect ohmmeter leads to pins K and N and check for less than 0.1 Ohm

- a. If ohmmeter indicates more than 0.1 Ohm for either test, replace vehicle lights switch (WP 0105).
- b. If ohmmeter indicates less than 0.1 Ohm for both tests, check for open circuit in wire between terminal N of cable connector and blackout stop lights.

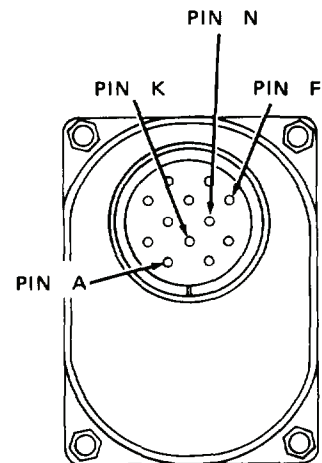

TA126914

**MALFUNCTION**  
**TEST OR INSPECTION**  
**CORRECTIVE ACTION**

**6. SERVICE STOP LIGHTS INOPERATIVE.**

**NOTE**

If one stop light operates normally, replace bulb in affected stop light (WP 0115). If stop light is still inoperative, check for open circuit in wire between inoperative stop light and operating stop light.

- Step 1. Unscrew and remove cable connector from bottom of vehicle lights switch.
- a. Place main switch lever on vehicle lights switch in STOP LIGHT or SER. DRIVE position.
  - b. Connect ohmmeter leads to pins A and F of vehicle lights switch and check for less than 0.1 Ohm, then connect ohmmeter leads to pins K and C and check for less than 0.1 Ohm.
    - 1. If ohmmeter indicates more than 0.1 Ohm for either test, replace vehicle lights switch (WP 0105).
    - 2. If ohmmeter indicates less than 0.1 Ohm for both tests, check for open circuit in wire between terminal C of cable connector and service stop lights. If continuity test of wire is satisfactory, proceed to step 2.

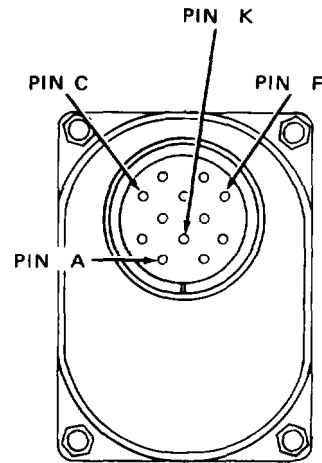

TA126915

- Step 2. Disconnect wires from stop light switch and connect ohmmeter leads to terminals of stop light switch. Note ohmmeter indication while an assistant depresses brake pedal.
- a. If ohmmeter does not indicate less than 0.2 Ohm, replace stop light switch (WP 0126).
  - b. If ohmmeter indicates less than 0.2 Ohm with brake pedal depressed, check for open circuit in wiring between stop light switch and terminals A and K of cable connector.

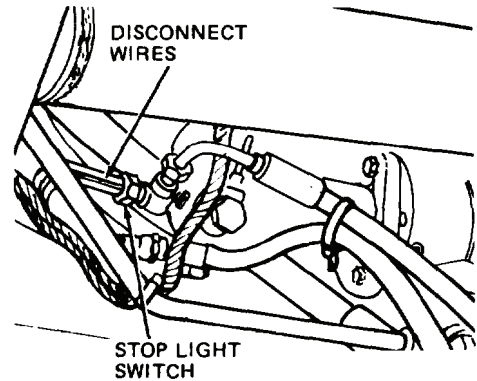

TA126916

---

**MALFUNCTION**  
**TEST OR INSPECTION**  
**CORRECTIVE ACTION**

---

**7. REAR FLOODLIGHTS INOPERATIVE.****NOTE**

If one rear floodlight operates normally, replace bulb in affected floodlight (WP 0111). If floodlight is still inoperative, check for open circuit in wire between inoperative floodlight and rear flood switch.

- Step 1. Turn ignition switch to OFF and remove key.
- a. Disconnect 6 ampere circuit breaker wire from terminal on rear flood switch.
  - b. Connect ohmmeter leads to leads of 6 ampere circuit breaker.
    1. If ohmmeter indicates less than 0.1 Ohm, proceed to step 2.
    2. If ohmmeter indicates more than 0.1 Ohm, connect ohmmeter leads to vehicle ground and wire on terminal of rear flood switch. If ohmmeter indicates less than 4.5 Ohms, check for short in wiring between rear flood switch and rear floodlights. Replace 6 ampere circuit breaker after short is removed (WP 0104).
- Step 2. Connect ohmmeter leads to terminals of rear flood switch and set rear flood switch at ON position.
- a. If ohmmeter indicates less than 0.1 Ohm, reconnect lead of 6 ampere circuit breaker to terminal of rear flood switch and troubleshoot vehicle lights switch (MALFUNCTION 1 in this work package).
  - b. If ohmmeter indicates more than 0.1 Ohm, replace rear flood switch (WP 0104).

---

MALFUNCTION	TEST OR INSPECTION	CORRECTIVE ACTION
-------------	--------------------	-------------------

---

## 8. GAGE LIGHTS INOPERATIVE.

### NOTE

If one gage light operates normally, replace bulb in affected gage light (WP 0202). If gage light is still inoperative, check for open circuit in wire between inoperative gage light and operating gage light.

Unscrew and remove cable connector from bottom of VEHICLE LIGHTS switch.

- a. Place main switch lever in any position other than OFF, and place auxiliary switch lever in PARK or DIM position.
- b. Connect ohmmeter leads to pins B and F of vehicle lights switch and check for 20 to 30 Ohms indication on ohmmeter, then place auxiliary switch lever in PANEL BRT. position and check for less than 0.1 Ohm indication on ohmmeter.
  1. If ohmmeter indicates more than 0.1 Ohm in PANEL BRT. position, or does not indicate 20 to 30 Ohms in PARK and DIM positions, replace vehicle lights switch (WP 0105).
  2. If vehicle lights switch resistance tests are satisfactory, check for open circuit in wire or 40 Ohm resistor between terminal B of cable connector and gage lights.

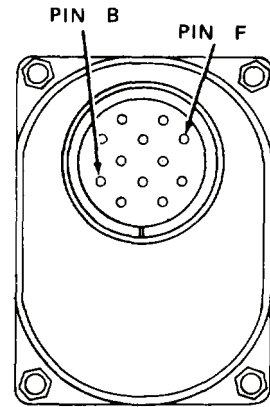

TA126917

**END OF WORK PACKAGE**



# ORGANIZATIONAL TROUBLESHOOTING PROCEDURES

## INSTRUMENT PANEL TROUBLESHOOTING

MALFUNCTION	TEST OR INSPECTION	CORRECTIVE ACTION
-------------	--------------------	-------------------

### NOTE

Refer to WP 0027 for oil pressure gage and fuel level gage troubleshooting, and WP 0014 for alternator warning light troubleshooting. Other switches and lights are covered in the paragraphs that cover the systems of which they are a part.

#### 1. WARNING LIGHTS INOPERATIVE.

- Step 1. Turn and hold ignition switch at LAMP TEST position.
- If at least one warning indicator (engine temperature, transmission temperature, or hydraulic filter) is on, check for open circuit in wiring, connector, or isolation diode between inoperative warning light and ignition switch. If circuit check is satisfactory, replace warning light (WP 0108).
  - If at least one warning indicator is not on, turn ignition switch to ON position and check if a slight buzz can be heard at electric fuel pump. If slight buzz indicating electric fuel pump operation is not heard, troubleshoot ignition switch (WP 0018, MALFUNCTION 2). If slight buzz is heard, check for open circuit in wiring between transmission temperature warning light and 6 ampere circuit breaker. If circuit check is satisfactory, proceed to step 2.
- Step 2. Disconnect wires from engine temperature, transmission temperature, oil pressure, and hydraulic filter switches.
- Temporarily connect a jumper from each wire to vehicle ground and turn ignition switch to ON position.
  - Engine temperature, transmission temperature, oil pressure, and hydraulic filter warning lights should be on.

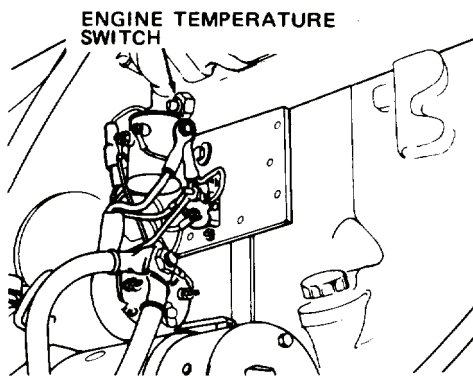

TA126918

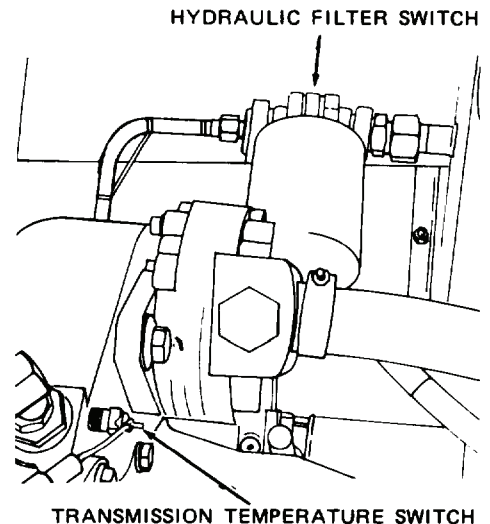

TA126919

---

**MALFUNCTION**  
**TEST OR INSPECTION**  
**CORRECTIVE ACTION**

---

**1. WARNING LIGHTS INOPERATIVE (CONTINUED).**

1. If warning light is on during test, and inoperative during high temperature or low oil pressure vehicle operation, replace associated warning light switch (WP 0108).
2. If warning light is not on, check for open circuit in wiring or 40 Ohm resistor between inoperative warning light and associated warning light switch.

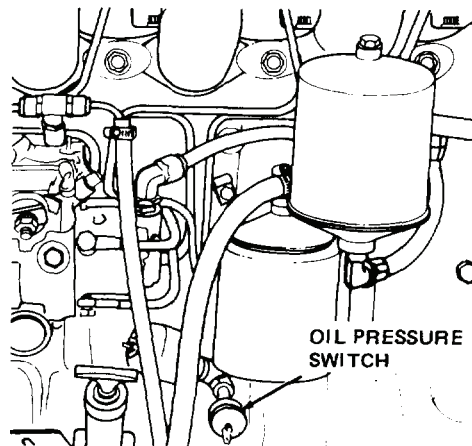

TA126920

**2. WARNING LIGHTS, BACK-UP ALARM, AND ELECTRIC FUEL PUMP INOPERATIVE.**

Turn ignition switch to ON position and depress start switch.

- a. If starter cranks engine, replace 6 ampere circuit breaker at IGN terminal of ignition switch.
- b. If starter does not crank engine, connect voltmeter leads to BATT terminal of ignition switch and vehicle ground. If voltmeter indicates 24 VDC, replace ignition switch (WP 0106). If voltmeter does not indicate 24 VDC, check for open circuit in wiring between ignition switch BATT terminal and 25 ampere circuit breaker.

**END OF WORK PACKAGE**



# ORGANIZATIONAL TROUBLESHOOTING PROCEDURES

## TRANSMISSION TROUBLESHOOTING

MALFUNCTION	TEST OR INSPECTION	CORRECTIVE ACTION
-------------	--------------------	-------------------

### 1. FOAMY OIL.

- |         |   |  |
|---------|---|--|
| Step 1. | Check oil level with transmission at operating temperature and engine operating.  |  |
|         | a. If oil level is not between FULL and ADD marks, add oil (refer to LO 10-3930-638-12).  |  |
|         | b. If oil level is between FULL and ADD marks, proceed to step 2.   |  |
| Step 2. | Check source of oil and ensure oil is correct grade and type.   |  |
|         | a. If oil is not correct grade and type, drain oil, replace oil filter, and add new oil (WP 0143) (refer to LO 10-3930-638-12). |  |
|         | b. If oil is correct grade and type, proceed to step 3.   |  |
| Step 3. | Remove transmission oil level dipstick and check for water on dipstick.   |  |
|         | a. If water is on dipstick, drain oil, replace oil filter, and add new oil (WP 0143) (refer to LO 10-3930-638-12).              |  |
|         | b. If water is not on dipstick, proceed to step 4.  |  |
| Step 4. | Check if charging pump mounting bolts are loose.  |  |
|         | If charging pump mounting bolts are loose, tighten them.  |  |

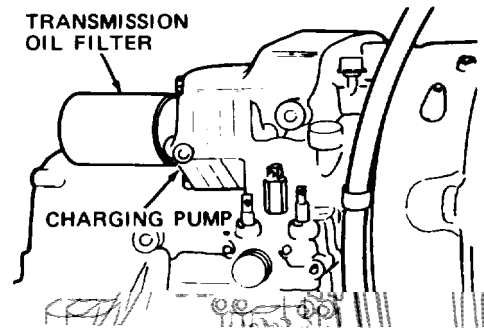

TA126952

---

**MALFUNCTION**  
**TEST OR INSPECTION**  
**CORRECTIVE ACTION**

---

**2. SLOW OR ERRATIC TRANSMISSION SHIFTING.**

- Step 1. Check oil level with transmission at operating temperature and engine operating.
- If oil level is not between FULL and ADD marks, add oil (refer to LO 10-3930-638-12).
  - If oil level is between FULL AND ADD marks, proceed to step 2.
- Step 2. Check oil filter for leakage and/or damage.
- If oil filter is leaking, tighten; if damaged, replace (WP 0146).
  - If oil filter is not leaking or damaged, proceed to step 3.
- Step 3. Remove screen assembly and check if dirty or damaged (WP 0144).
- If screen assembly is dirty, clean; if damaged, replace (WP 0144).
  - If screen assembly checks okay, proceed to step 4.
- Step 4. Check transmission linkage for proper adjustment or damage (WP 0148).
- If transmission linkage is not adjusted properly, adjust; if damaged, repair by replacing damaged part or parts (WP 0148).
  - If transmission linkage is okay, check speed control cable for damage; replace if necessary (WP 0148).

**3. HIGH TRANSMISSION OIL TEMPERATURE.**

- Step 1. Check oil level with transmission at operating temperature and engine operating.
- If oil level is not between FULL and ADD marks, add oil (refer to LO 10-3930-638-12).
  - If oil level is between FULL and ADD marks, proceed to step 2.
- Step 2. Check transmission oil cooler for clogged fins or obstruction, leakage, or damage.
- If oil cooler fins are clogged, clean; if fins are obstructed, remove obstructions. If oil cooler is leaking or damaged, replace oil cooler (WP 0153).
  - If oil cooler is okay, proceed to step 3.
- Step 3. Check hoses and lines between transmission and oil cooler for leakage or damage.
- If hoses and lines between transmission and oil cooler are leaking or damaged, replace (WP 0152).
  - If hoses and lines between transmission and oil cooler are okay, proceed to step 4.
- Step 4. Check transmission temperature indicator and switch (electrical system) (WP 0018 and WP 0121, respectively).
- If transmission temperature indicator is defective, replace it (WP 0108); if transmission temperature switch is defective, replace it (WP 0121).
  - If transmission temperature indicator and switch are okay, proceed to step 6.
- Step 5. Check oil filter for leakage or damage.
- If oil filter is leaking, tighten it; if damaged, replace it (WP 0146).
  - If oil filter is okay, remove screen assembly (WP 0144) and check it for damage or clogged condition. Replace screen assembly if damaged; clean if clogged (WP 0144).

---

**MALFUNCTION**  
**TEST OR INSPECTION**  
**CORRECTIVE ACTION**

---

**4. LOSS OF DRIVE IN ALL RANGES.**

- Step 1. Check oil level with transmission at operating temperature and engine operating.
- If oil level is not between FULL and ADD marks, add oil (refer to LO 10-3930-638-12).
  - If oil level is between FULL and ADD marks, proceed to step 2.
- Step 2. Check if axle disconnect lever is in disengaged position (pulled outward).
- If axle disconnect lever is in disengaged position (pulled outward), place in engaged position.
  - If axle disconnect lever is in engaged position, proceed to step 3.

- Step 3. Observe control valve assembly linkage while an assistant moves direction selector and speed selector through their entire range.

Movement of control valve assembly forward and reverse and speed selector spools should be observed.

- If movement is not observed, replace/repair cables/linkages (WP 0148).
- If movement is observed, proceed to step 4.

- Step 4. Disconnect linkage at control valve assembly valve spools.
- Start engine, operate at idle speed, and set parking brake.

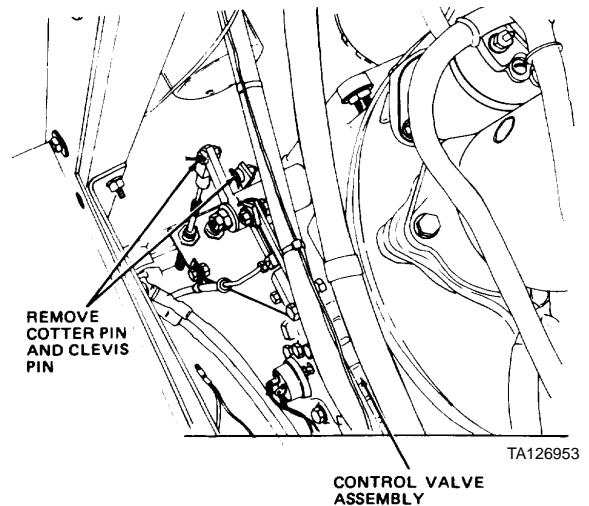

**NOTE**

Do not depress service brake pedal. Depressing service brake pedal activates declutch valve in turn, neutralizing transmission.

- With an assistant in operator's seat, move control valve assembly direction selector spool and speed selector spool slowly through their entire range of travel.
- Movement of vehicle should be observed.
  - If vehicle moves, adjust transmission linkage controls (WP 0148).
  - If vehicle does not move, proceed to step 5.

---

**MALFUNCTION**  
**TEST OR INSPECTION**  
**CORRECTIVE ACTION**

---

#### 4. LOSS OF DRIVE IN ALL RANGES (CONTINUED).

- Step 5. Disconnect and cap hose connected to control valve assembly hydraulic actuator assembly.
- Start engine and operate at idle speed and set parking brake.
  - With an assistant in operator's seat, move control valve assembly direction selector spool and speed selector spool slowly through their entire range of travel.
  - Movement of vehicle should be observed.
    - If vehicle does not move, replace control valve assembly (notify Direct Support Maintenance).
    - If vehicle moves, replace or adjust declutch valve (WP 0167).

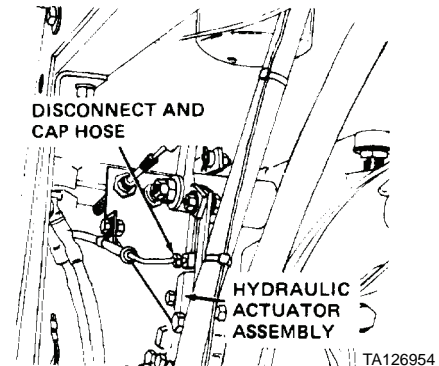

#### 5. LOSS OF POWER.

- Step 1. Check for foamy oil (MALFUNCTION 1 in this work package).
- Step 2. Remove parking brake drum (WP 0162) and check for locked parking brake linings.
- If linings are locked in position, disassemble parking brake and inspect parts (WP 0162); replace defective parts (WP 0162).
  - If linings are not locked in position, reinstall parking brake drum (WP 0162) and proceed to step 3.
- Step 3. Place blocks (6 x 6 x 18 in. wood blocks) at each wheel to prevent vehicle from moving.
- Install shipping lock pin (WP 0044).
  - Ensure that parking brake lever is in released position.



#### WARNING

Before raising wheel off ground, ensure shipping lock pin is installed. Failure to do so may cause vehicle to turn and slip off jack or jack stands causing serious injury or death. If you are injured by falling equipment, obtain medical aid immediately.

- Raise one axle off ground.
- Rotate wheel by hand and ensure wheel rotates freely without excessive drag.
- Repeat for remaining wheel.
- Repeat for remaining axle.
  - If a wheel does not rotate freely without excessive drag or is locked, adjust brakes (WP 0163).
  - If wheels rotate freely, lower axle to ground, remove shipping lock pin and blocks. Check drive shafts and universal joints for damage (WP 0154, WP 0155, and WP 0156); repair or replace as necessary (WP 0154, WP 0155, and WP 0156).

**END OF WORK PACKAGE**

# ORGANIZATIONAL TROUBLESHOOTING PROCEDURES

## AXLES AND DRIVE SHAFT ASSEMBLIES TROUBLESHOOTING

### MALFUNCTION

### TEST OR INSPECTION

### CORRECTIVE ACTION

#### 1. LUBRICANT LEAKING FROM DIFFERENTIAL BREATHER.

Check oil level (WP 0157).

Drain to proper level (WP 0157).

#### 2. CONTINUOUS AXLE OR WHEEL NOISE.

Step 1. Check lubricant level (WP 0157).

- a. If lubricant level is below fill plug opening, add lubricant (refer to LO 10-3930-638-12) to fill plug opening then reinstall fill plug.
- b. If lubricant level is okay, proceed to step 2.



### WARNING

Before raising wheel off ground, ensure shipping lock pin is installed. Failure to do so may cause vehicle to turn and slip off jack or jack stands causing serious injury or death. If you are injured by falling equipment, obtain medical aid immediately.

Step 2. Check wheel bearing for proper adjustment (raise wheel and use pry bar to check any noticeable end play) or damage.

Repeat for other wheels.

- a. If end play is noticeable, adjust or replace wheel bearing (WP 0160).
- b. If end play is okay, proceed to step 3.

Step 3. Check axle shafts for damage (WP 0160).

- a. If axle shafts damaged, replace (WP 0160).
- b. If axle shafts are not damaged, notify Direct Support Maintenance.

#### 3. DIFFERENTIAL CARRIER ASSEMBLY OVERHEATING.

Check lubricant level (WP 0157).

Add lubricant (WP 0157).

#### 4. LUBRICANT LEAKING FROM DIFFERENTIAL CARRIER ASSEMBLY.

Check axle breather for damage or clogged condition (WP 0158 and WP 0159).

- a. If axle breather is damaged or clogged, clean or replace it (WP 0158 and WP 0159).
- b. If axle breather is okay, notify Direct Support Maintenance.

---

**MALFUNCTION**  
**TEST OR INSPECTION**  
**CORRECTIVE ACTION**

---

**5. EXCESSIVE NOISE OR VIBRATION IN DRIVE SHAFT ASSEMBLIES.**

- Step 1. Check for loose universal joint mounting bolts (WP 0154, WP 0155, and WP 0156).
- a. If universal joint mounting bolts are loose, tighten (WP 0154, WP 0155, and WP 0156).
  - b. If universal joint mounting bolts are tight, proceed to step 2.
- Step 2. Check drive shaft assemblies for insufficient lubrication, wear, or damage (indicated by excessive movement between universal joint and drive shaft assembly in any direction).
- a. If drive shaft assemblies are insufficiently lubricated, lubricate (WP 0154, WP 0155, and WP 0156); if worn or damaged, repair or replace drive shaft assembly (WP 0154, WP 0155, and WP 0156).
  - b. If drive shaft assemblies are lubricated and are not worn or damaged, check for a bent drive shaft assembly (WP 0159, WP 0160, and WP 0161). Replace a bent drive shaft assembly (WP 0154, WP 0155, and WP 0156).

**END OF WORK PACKAGE**

# ORGANIZATIONAL TROUBLESHOOTING PROCEDURES

## BRAKE SYSTEM TROUBLESHOOTING

MALFUNCTION	TEST OR INSPECTION	CORRECTIVE ACTION
-------------	--------------------	-------------------

### 1. PARKING BRAKE DOES NOT APPLY (WILL NOT HOLD).

Step 1. Release parking brake lever and turn knob on top of lever clockwise to adjust cable. Pull parking brake lever up while observing actuating lever. Actuating lever should move.

- a. If actuating lever moves, proceed to step 3.
- b. If actuating lever does not move, proceed to step 2.

Step 2. Check for missing or loose clamps, and missing hardware at parking brake cable connections to parking brake lever and actuating lever (WP 0161).

- a. Install missing parts, tighten loose parts, and/or adjust parking brake linkage (WP 0161).
- b. If parts are not missing or loose, or do not require adjustment, replace parking brake cable (WP 0161).

Step 3. Remove six capscrews and lockwashers securing brake drum to brake flange (WP 0162). Inspect brake linings for worn condition and actuating lever for damage (WP 0162).

Replace worn brake linings and/or damaged actuating lever (WP 0162).

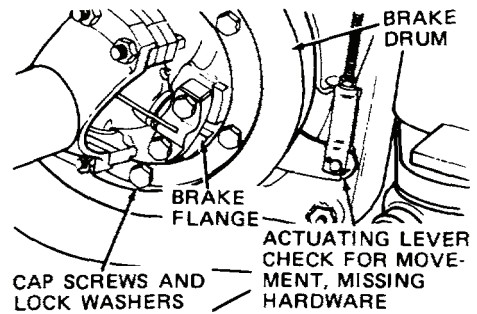

TA126985

### 2. UNEVEN OR ERRATIC SERVICE BRAKES.

Step 1. Check if air pressure is the same in each tire (should be 45 PSI).

- a. If air pressure in each tire is not 45 PSI, adjust tire pressure.
- b. If air pressure is okay, proceed to step 2.

Step 2. Check hydraulic brake valve for leaking condition (WP 0166).

- a. If hydraulic brake valve is leaking, replace it (WP 0166).
- b. If hydraulic brake valve is okay, proceed to step 3.

Step 3. Place blocks (6 x 6 x 18 in. wood blocks) at each wheel to prevent vehicle from moving. Remove shipping lock pin from storage area under operator's seat (WP 0044) and install in chassis. Ensure parking brake is applied.

---

**MALFUNCTION**  
**TEST OR INSPECTION**  
**CORRECTIVE ACTION**

---

**2. UNEVEN OR ERRATIC SERVICE BRAKES (CONTINUED).**



**WARNING**

Before raising wheel off ground, ensure shipping lock pin is installed. Failure to do so may cause vehicle to turn and slip off jack or jack stands causing serious injury or death. If you are injured by falling equipment, obtain medical aid immediately.

- a. Raise one axle and wheels from ground.
  - b. Remove both wheel axle shafts and hub and drum assemblies (WP 0160).
  - c. Check wheel cylinders for leaking condition or sticking piston (WP 0163, step 1).
  - d. Repeat for other axle and wheels.
    1. If wheel cylinder is leaking or piston is sticking, replace wheel cylinder (WP 0163).
    2. If wheel cylinder is okay, proceed to step 4.
- Step 4. Check brake linings for wear, uneven wear, glaze, brake fluid or lubricant contamination, or excessive dust.
- a. Replace brake linings if worn, glazed, or contaminated; remove excessive dust (WP 0163).
  - b. If brake linings are okay, proceed to step 5.
- Step 5. Check hub and drum assemblies for scored or cracked condition (WP 0160).
- a. Replace brake drums if scored or cracked (WP 0160).
  - b. If hub and drum assemblies are okay, proceed to step 6.
- Step 6. Check for loose, missing, or damaged brake shoe mounting hardware (WP 0163).  
 Replace missing or damaged brake shoe mounting hardware; install new hardware if missing.

**3. SERVICE BRAKES SPONGY.**

**NOTE**

If service brakes are spongy, bleed air from brake system as described in WP 0163. If brakes are still spongy, then proceed to step 1.

- Step 1. Check brake lines and connections between hydraulic brake valve and wheel cylinders for brake fluid leaks (WP 0164).
- a. If connections are leaking fluid, tighten; if brake lines are leaking fluid, replace (WP 0164).
  - b. If brake lines and connections are okay, proceed to step 2.
- Step 2. Check hydraulic brake valve for leaking condition (WP 0166).
- a. If hydraulic brake valve master cylinder is leaking fluid, replace it (WP 0166).
  - b. If hydraulic brake valve is okay, proceed to step 3.
- Step 3. Place blocks (6 x 6 x 18 in. wood blocks) at each wheel to prevent vehicle from moving. Remove shipping lock pin from storage area under operator's seat (WP 0044) and install in chassis. Ensure parking brake is applied.



---

**MALFUNCTION**  
**TEST OR INSPECTION**  
**CORRECTIVE ACTION**

---

**3. SERVICE BRAKES SPONGY (CONTINUED).**



**WARNING**

Before raising axle off ground, ensure shipping lock pin is installed. Failure to do so may cause vehicle to turn and slip off jack or jack stands causing serious injury or death. If you are injured by falling equipment, obtain medical aid immediately.

- a. Raise one axle and wheels from ground.
- b. Remove both wheel axle shafts and hub and drum assemblies (WP 0160).
- c. Check wheel cylinders for leaking condition or sticking piston (WP 0163, step 1).
- d. Repeat for other axle and wheels.
  1. If wheel cylinder is leaking or piston is sticking, replace wheel cylinder (WP 0163).
  2. If wheel cylinder is okay, reinstall hub and drum assemblies and axle shafts (WP 0160), lower axle and wheels to ground, remove shipping lock pin (store under operator's seat), and remove blocks from wheels. Replace or repair hydraulic brake valve master cylinder (WP 0165).

**4. SERVICE BRAKES GRAB.**

- Step 1. Check source of brake fluid to ensure brake fluid is correct type; also check for contaminated brake fluid.
  - a. If incorrect brake fluid was used or if brake fluid is contaminated, drain brake system of brake fluid and refill using correct brake fluid (refer to LO 10-3930-638-12) (WP 0163).
  - b. If brake fluid is okay, proceed to step 2.
- Step 2. Check brake pedal/return spring linkage for binding, interference, missing parts, or damage (WP 0168).
  - a. If brake pedal/return spring linkage is binding, has interference, is missing parts, or is damaged, repair or replace (WP 0168).
  - b. If brake pedal/return spring are okay, proceed to step 3.
- Step 3. Check hydraulic brake valve for damage/leaking condition (WP 0166).
  - a. If hydraulic brake valve is damaged or leaking, repair or replace it (WP 0166).
  - b. If hydraulic brake valve is okay, proceed to step 4.
- Step 4. Place blocks (6 x 6 x 18 in. wood blocks) at each wheel to prevent vehicle from moving. Remove shipping lock pin from storage area under operator's seat (WP 0044) and install in chassis. Ensure parking brake is in released position.

---

**MALFUNCTION**  
**TEST OR INSPECTION**  
**CORRECTIVE ACTION**

---

**4. SERVICE BRAKES GRAB (CONTINUED).**



**WARNING**

Before raising axle off ground, ensure shipping lock pin is installed. Failure to do so may cause vehicle to turn and slip off jack or jack stands causing serious injury or death. If you are injured by falling equipment, obtain medical aid immediately.

- a. Raise one axle and wheels off ground.
  - b. Rotate wheel by hand; there should be a very slight drag on wheel.
  - c. Repeat above for remaining wheel and axle.
    1. If there is a very slight drag on wheels, proceed to step 5.
    2. If there is excessive drag on wheels, adjust brakes (WP 0163).
- Step 5. Remove axle shafts and hub and drum assemblies from one axle (WP 0160). Check brake shoe return spring (WP 0163). Repeat above for remaining axle.
- a. If brake shoe return spring is permanently set, replace (WP 0163).
  - b. If brake shoe return spring is okay, proceed to step 6.
- Step 6. Check wheel cylinders for leaking condition or sticking piston (WP 0163 step 1).
- a. If wheel cylinder is leaking or piston is sticking, replace wheel cylinder (WP 0163).
  - b. If wheel cylinder is okay, reinstall hub and drum assemblies and axle shafts (WP 0160), lower axle and wheels to ground, remove shipping lock pin (store under operator's seat) and remove blocks from wheels. Replace or repair hydraulic brake valve (WP 0166).

**5. SERVICE BRAKES SQUEAK.**

- Step 1. Place blocks (6 x 6 x 18 in. wood blocks) at each wheel to prevent vehicle from moving. Remove shipping lock pin from storage area under operator's seat (WP 0044) and install in chassis. Ensure parking brake is in applied position.



**WARNING**

Before raising axle off ground, ensure shipping lock pin is installed. Failure to do so may cause vehicle to turn and slip off jack or jack stands causing serious injury or death. If you are injured by falling equipment, obtain medical aid immediately.

- a. Raise one axle and wheels off ground.
- b. Remove axle shafts and hub drum assemblies (WP 0160).
- c. Check brake linings for wear, uneven wear, glaze, brake fluid or lubricant contamination, and/or excessive dust.
- d. Repeat for other axle and wheels.
  1. Replace brake linings that are worn, glazed, or contaminated; remove excessive dust (WP 0163).
  2. If brake linings are okay and there is no excessive dust, proceed to step 2.

---

**MALFUNCTION**  
**TEST OR INSPECTION**  
**CORRECTIVE ACTION**

---

**5. SERVICE BRAKES SQUEAK (CONTINUED).**

- Step 2. Check hub and drum assembly for scored condition (WP 0163).
- a. If hub and drum assembly is scored, replace brake drum (WP 0163).
  - b. If hub and drum assembly is okay, check for damaged brake shoe return spring (WP 0161); replace brake shoe return spring (WP 0161).

**6. SERVICE BRAKES OVERHEAT.**

- Step 1. Check brake pedal/return spring linkage for binding, interference, missing parts, or damage (WP 0168).
- a. If brake pedal/return spring linkage is binding, has interference, is missing parts or damaged, repair or replace (WP 0168).
  - b. If brake pedal/return spring are okay, proceed to step 2.
- Step 2. Place blocks (6 x 6 x 18 in. wood blocks) at each wheel to prevent vehicle from moving. Remove shipping lock pin from storage area under operator's seat (WP 0044) and install in chassis. Ensure parking brake is in released position.



**WARNING**

Before raising axle off ground, ensure shipping lock pin is installed. Failure to do so may cause vehicle to turn and slip off jack or jack stands causing serious injury or death. If you are injured by falling equipment, obtain medical aid immediately.

- a. Raise one axle and wheels off ground.
  - b. Rotate wheel by hand: there should be a very slight drag on wheel.
  - c. Repeat above for remaining wheel and axle.
    1. If there is a very slight drag on wheels, proceed to step 3.
    2. If there is excessive drag on wheels, adjust brakes (WP 0163).
- Step 3. Remove axle shafts and hub and drum assemblies from one axle (WP 0160). Check brake shoe return spring (WP 0161). Repeat above for remaining axle.
- a. If brake shoe return spring is permanently set, replace (WP 0163).
  - b. If brake shoe return spring is okay, proceed to step 4.
- Step 4. Check wheel cylinders for leaking condition or sticking piston (WP 0163, step 1).  
 If wheel cylinder is leaking or piston is sticking, replace wheel cylinder (WP 0163).

---

<b>MALFUNCTION</b>
<b>TEST OR INSPECTION</b>
<b>CORRECTIVE ACTION</b>

---

**7. EXCESSIVE SERVICE BRAKE PEDAL TRAVEL.****NOTE**

If there is excessive brake pedal travel, add brake fluid to master cylinder (WP 0165) and bleed air from brake system as described in WP 0163. If brake pedal travel is still excessive proceed to step 1 below.

- Step 1. Check adjustment of service brake pedal free travel (WP 0168).
- If service brake pedal is not adjusted properly, adjust (WP 0166).
  - If adjustment is okay, proceed to step 2.
- Step 2. Check hydraulic brake valve for damage/leaking condition (WP 0166).
- If hydraulic brake valve is damaged or leaking, repair or replace it (WP 0166).
  - If hydraulic brake valve is okay, proceed to step 3.
- Step 3. Check brake lines and connections between hydraulic brake valve and wheel cylinders for brake fluid leaks (WP 0164).
- If connections are leaking fluid, tighten; if brake lines are leaking fluid, replace (WP 0164).
  - If brake lines and connections are okay, proceed to step 4.
- Step 4. Place blocks (6 x 6 x 18 in. wood blocks) at each wheel to prevent vehicle from moving. Remove shipping lock pin from storage area under operator's seat (WP 0044) and install in chassis. Ensure that parking brake is applied.

**WARNING**

Before raising axle off ground, be sure that shipping lock pin is installed. Failure to do so may cause vehicle to turn and slip off jack or jack stands causing serious injury or death. If you are injured by falling equipment, obtain medical aid immediately.

- Raise one axle and wheels from ground.
  - Remove both axle shafts and hub and drum assemblies (WP 0160).
  - Check wheel cylinders for leaking condition or sticking piston (WP 0163).
  - Repeat for other axle and wheels.
    - If wheel cylinder is leaking or piston is sticking, replace wheel cylinder (WP 0163).
    - If wheel cylinder is okay, proceed to step 5.
- Step 5. Check brake linings for excessive wear (WP 0163).
- Step 6. If brake linings are worn excessively, replace (WP 0163).
- If brake linings are not worn excessively, adjust brakes (WP 0163).

---

**MALFUNCTION**  
**TEST OR INSPECTION**  
**CORRECTIVE ACTION**

---

**8. EXCESSIVE SERVICE BRAKE PEDAL EFFORT REQUIRED.**

- Step 1. Check brake lines and connections between hydraulic brake valve and wheel cylinders for brake fluid leaks (WP 0162).
- If connections are leaking fluid, tighten; if brake lines are leaking fluid, replace (WP 0162).
  - If brake lines and connections are okay, proceed to step 2.
- Step 2. Check brake pedal/return spring linkage for binding, interference, missing parts, or damage (WP 0168).
- If brake pedal/return spring linkage is binding, has interference, is missing parts or damaged, repair or replace (WP 0168).
  - If brake pedal/return are okay, proceed to step 3.
- Step 3. Place blocks (6 x 6 x 18 in. wood blocks) at each wheel to prevent vehicle from moving. Remove shipping lock pin from storage area under operator's seat (WP 0044) and install in chassis. Ensure that parking brake is applied.



**WARNING**

Before raising axle off ground, ensure shipping lock pin is installed. Failure to do so may cause vehicle to turn and slip off jack or jack stands causing serious injury or death. If you are injured by falling equipment, obtain medical aid immediately.

- Raise one axle and wheels from ground.
  - Remove both axle shafts and hub and drum assemblies (WP 0160).
  - Check wheel cylinders for leaking condition or sticking piston (WP 0163, step 1).
  - Repeat for other axle and wheels.
  - If wheel cylinder is leaking or piston is sticking, replace wheel cylinder (WP 0163).
  - If wheel cylinder is okay, proceed to step 4.
- Check brake linings for wear, glaze, and excessive dust (WP 0163).
  - Replace brake linings if worn, or glazed; remove excessive dust (WP 0163).
  - If brake linings are okay, reinstall hub and drum assemblies, axle shafts (WP 0160), lower axle and wheels to ground, remove shipping lock pin (store under operator's seat), and remove blocks from wheels. Proceed to step 5.
- Operate all control levers several times with engine off to relieve hydraulic pressure. Depress service brake pedal and note pedal effort required. Start engine, depress service brake pedal and note pedal effort required.
  - If required pedal effort is the same with engine off or on, proceed to step 6.
  - If less pedal effort is required with engine running, proceed to step 7.

**MALFUNCTION**  
**TEST OR INSPECTION**  
**CORRECTIVE ACTION**

**8. EXCESSIVE SERVICE BRAKE PEDAL EFFORT REQUIRED (CONTINUED).**

- Step 6. Operate lift control lever with engine at full throttle. Ensure mast assembly operates normally.
- a. If mast assembly operates normally, proceed to step 7.
  - b. If mast assembly does not operate normally, troubleshoot hydraulic system (WP 0023, MALFUNCTION 1).

Step 7. Operate all levers several times with engine off. Remove plug or cap from hydraulic pump and install 0 to 3,000 PSI pressure gage.

- a. Start engine and, with transmission in Neutral, operate at fast idle.
- b. Operate and hold lift control lever towards you until tube assembly is warm to touch (mast assembly will be at full height).
- c. Operate engine at 1,700 to 1,900 RPM. With lift control lever held towards you, note and record pressure gage reading; then pump service brake pedal several times.
- d. Depress service brake pedal and record new pressure gage reading.
- e. Compare difference between pressure gage readings (relief pressure).
- f. If difference between pressure gage readings is not 245 to 255 PSI, replace or repair power assist unit (WP 0166).

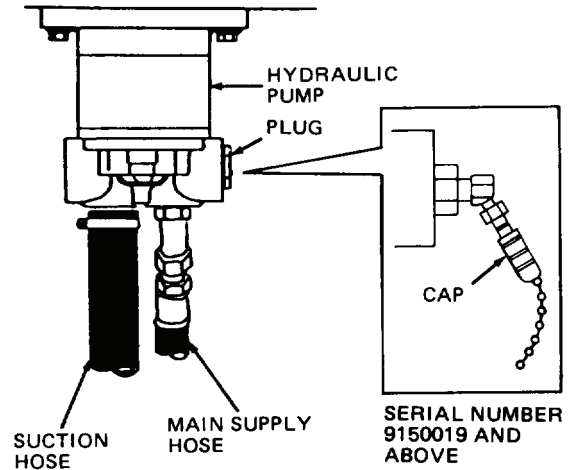

TA301524

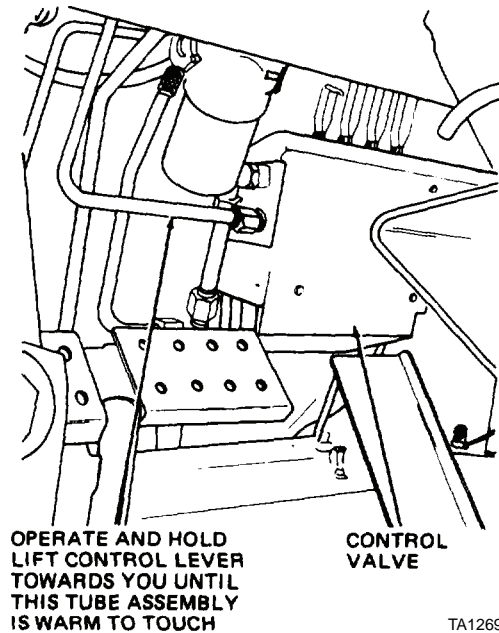

TA126987

**9. SERVICE BRAKES GROAN AT END OF STOP.**

- Step 1. Place blocks (6 x 6 x 18 in. wood blocks) at each wheel to prevent vehicle from moving. Remove shipping lock pin from storage area under operator's seat (WP 0044) and install in chassis. Ensure parking brake is applied.

---

**MALFUNCTION**  
**TEST OR INSPECTION**  
**CORRECTIVE ACTION**

---

**9. SERVICE BRAKES GROAN AT END OF STOP (CONTINUED).**



**WARNING**

Before raising wheel off ground, ensure shipping lock pin is installed. Failure to do so may cause vehicle to turn and slip off jack or jack stands causing serious injury or death. If you are injured by falling equipment, obtain medical aid immediately.

- a. Raise one axle and wheels from ground.
  - b. Remove both axle shafts and hub and drum assemblies (WP 0160).
  - c. Check brake linings for wear, uneven wear, brake fluid/lubricant contamination, or excessive dust (WP 0163).
  - d. Repeat for other axle.
    1. Replace brake linings if worn or contaminated: remove excessive dust (WP 0163).
    2. If brake linings are okay, proceed to step 2.
- Step 2. Check hub and drum assemblies for scored or cracked condition (WP 0160).
- a. Replace brake drums if scored or cracked (WP 0160).
  - b. If hub and drum assemblies are okay, proceed to step 3.
- Step 3. Check for loose, missing, or damaged brake shoe mounting hardware (WP 0163).
- Replace missing or damaged brake shoe mounting hardware; install new hardware if missing.

**10. SCRAPING NOISE FROM SERVICE BRAKES WHEN APPLIED.**

- Step 1. Place blocks (6 x 6 x 18 in. wood blocks) at each wheel to prevent vehicle from moving. Remove shipping lock pin from storage area under operator's seat (WP 0044) and install in chassis. Ensure parking brake is applied.



**WARNING**

Before raising axle off ground, ensure shipping lock pin is installed. Failure to do so may cause vehicle to slip off jack or jack stands causing serious injury or death. If you are injured by falling equipment, obtain medical aid immediately.

- a. Raise one axle and wheels off ground.
- b. Remove both axle shafts and hub and drum assemblies (WP 0160).
- c. Check brake linings for wear, uneven wear, brake fluid/lubricant contamination (WP 0163). Repeat for other axle.
  1. Replace brake linings if worn or contaminated (WP 0163).
  2. If brake linings are okay, proceed to step 2.

---

**MALFUNCTION**  
**TEST OR INSPECTION**  
**CORRECTIVE ACTION**

---

**10. SCRAPING NOISE FROM SERVICE BRAKES WHEN APPLIED (CONTINUED).**

- Step 2. Check brake shoe return springs for damage (WP 0163).
- a. Replace spring if damaged (WP 0163).
  - b. If spring is okay, check brake assemblies for loose or missing brake shoe mounting hardware; tighten/replace brake shoe mounting hardware (WP 0163).

**11. STOP LIGHT INOPERATIVE.**

Refer to WP 0017, MALFUNCTION 4 for troubleshooting procedures.

**12. DECLUTCH PEDAL DOES NOT NEUTRALIZE TRANSMISSION.**

Disconnect center propeller shaft from brake flange (WP 0155). Block wheels, lightly apply parking brake, and idle engine. Observe transmission output shaft (brake flange) while an assistant depresses service brake pedal.

- a. If brake flange stops rotating, check adjustment of declutch valve (WP 0167). If adjustment is correct, replace declutch valve (WP 0167).
- b. If brake flange does not stop rotating, replace transmission control valve assembly (notify Direct Support Maintenance).

**END OF WORK PACKAGE**



# ORGANIZATIONAL TROUBLESHOOTING PROCEDURES

## WHEELS AND TIRES TROUBLESHOOTING

### MALFUNCTION

### TEST OR INSPECTION

### CORRECTIVE ACTION

#### 1. TIRE WEARING UNEVENLY.

- Step 1. Place blocks (6 x 6 x 18 in. wood blocks) at each wheel to prevent vehicle from moving. Remove shipping lock pin from storage area under operator's seat (WP 0044) and install in chassis. Ensure parking brake is in released position.



#### WARNING

Before raising axle off ground, ensure shipping lock pin is installed. Failure to do so may cause vehicle to turn and slip off jack or jack stands causing serious injury or death. If you are injured by falling equipment, obtain medical aid immediately.

- a. Raise one axle and wheels off ground.
  - b. Rotate wheel by hand; there should be a very slight drag on wheel.
  - c. Repeat above for remaining wheel and axle.
    1. If there is excessive drag on wheels, adjust brakes (WP 0163).
    2. If there is a very slight drag on wheels, proceed to step 2.
- Step 2. With wheel off ground (step 1), check wheel bearing adjustment (use pry bar to check for any noticeable end play).
- a. If there is any noticeable end play, adjust wheel bearing (WP 0160).
  - b. If there is no noticeable end play, remove axle shaft (WP 0160) and ensure wheel bearing is lubricated. If wheel bearing is lubricated, check it for damage (WP 0160); replace wheel bearing if necessary.

#### 2. NOISY OR BUMPING SOUND WHILE TRAVELING.

- Step 1. Check wheel lug nuts for tightness (should be tightened to 240 to 260 lb-ft [325 to 353 Nm]).
- a. If lug nuts are loose, tighten to 240 to 260 lb-ft (325 to 353 Nm).
  - b. If lug nuts are tight, proceed to step 2.
- Step 2. Place blocks (6 x 6 x 18 in. wood blocks) at each wheel to prevent vehicle from moving. Remove shipping lock pin from storage area under operator's seat (WP 0044) and install in chassis. Ensure parking brake is in released position.

---

**MALFUNCTION**  
**TEST OR INSPECTION**  
**CORRECTIVE ACTION**

---

**2. NOISY OR BUMPING SOUND WHILE TRAVELING (CONTINUED).****WARNING**

Before raising axle off ground, ensure shipping lock pin is installed. Failure to do so may cause vehicle to turn and slip off jack or jack stands causing serious injury or death. If you are injured by falling equipment, obtain medical aid immediately.

- a. Raise one axle and wheels off ground.
  - b. Rotate wheel by hand while listening for a rumbling or grinding sound within axle.
  - c. Repeat for other wheel and axle.
    1. If rumbling or grinding sound is heard, replace axle shaft (WP 0160).
    2. If rumbling or grinding sound is not heard, proceed to step 3.
- Step 3. With wheel off ground (step 2), check wheel bearing adjustment (use pry bar to check for any noticeable end play).
- a. If there is noticeable end play, adjust wheel bearing (WP 0160).
  - b. If there is no noticeable end play, proceed to step 4.
- Step 4. Remove axle shaft (WP 0160) and check wheel bearing for damage and insufficient lubricant (WP 0160).
- a. If insufficient lubricant, lubricate wheel bearing (WP 0165); if wheel bearing is damaged, replace (WP 0160).
  - b. If wheel bearing is okay, reinstall hub and drum assembly and axle shaft (WP 0169), and remove wheels and tires (WP 0169). Disassemble tire from wheel and check for foreign material or damage (WP 0169); remove foreign material or replace tire if damaged (WP 0169).

**END OF WORK PACKAGE**

---

## ORGANIZATIONAL TROUBLESHOOTING PROCEDURES

### STEERING SYSTEM TROUBLESHOOTING

---

MALFUNCTION
TEST OR INSPECTION
CORRECTIVE ACTION
<p><b>1. VEHICLE WILL NOT TURN WHEN STEERING WHEEL IS TURNED.</b></p> <p>Step 1. Check oil level in hydraulic reservoir. Oil level should be between FULL and ADD marks with mast lowered.</p> <p style="padding-left: 20px;">a. If oil level is not between FULL and ADD marks on dipstick with mast lowered, add oil (refer to LO 10-3930-638-12).</p> <p style="padding-left: 20px;">b. If oil level is okay, proceed to step 2.</p> <p>Step 2. Ensure steering bypass valve is closed (extreme clockwise position).</p> <p style="padding-left: 20px;">a. If steering bypass valve is not in closed position, turn to extreme clockwise position.</p> <p style="padding-left: 20px;">b. If steering bypass valve is closed, proceed to step 3.</p> <p>Step 3. Check for oil leaks at connections to steering cylinders.</p> <p style="padding-left: 20px;">a. If oil leaks are observed, tighten fittings or replace hoses (WP 0171).</p> <p style="padding-left: 20px;">b. If oil leaks are not observed, proceed to step 4.</p> <p>Step 4. Start engine and operate at full throttle.</p> <p style="padding-left: 20px;">a. Operate lift control lever, tilt control lever, and shift control lever.</p> <p style="padding-left: 20px;">b. Ensure mast assembly operates normally when levers are actuated.</p> <p style="padding-left: 40px;">1. If mast assembly does not operate normally, proceed to step 5.</p> <p style="padding-left: 40px;">2. If mast operates normally, replace steering gear (notify Direct Support Maintenance).</p> <p>Step 5. Check setting of relief valve (WP 0172, step 22).</p> <p style="padding-left: 20px;">a. If pressure indication is not 2,500 to 2,550 PSI (17,237 to 17,582 kPa), adjust relief valve (WP 0172, step 23).</p> <p style="padding-left: 20px;">b. If pressure indication is 2,500 to 2,550 PSI (17,237 to 17,582 kPa), replace steering gear (notify Direct Support Maintenance).</p> <p><b>2. VEHICLE TURNS CORRECTLY IN ONE DIRECTION BUT NOT IN OTHER DIRECTION.</b></p> <p>Step 1. Check hoses, lines, and fittings between steering gear and steering cylinders for oil leaks (WP 0171).</p> <p style="padding-left: 20px;">a. If oil leaks are observed, tighten fittings or replace hoses (WP 0171).</p> <p style="padding-left: 20px;">b. If oil leaks are not observed, proceed to step 2.</p> <p>Step 2. Check steering cylinders for oil leaks at rod end.</p> <p style="padding-left: 20px;">a. If oil leaks are observed, replace steering cylinder.</p> <p style="padding-left: 20px;">b. If oil leaks are not observed, proceed to step 3.</p>

---

**MALFUNCTION**  
**TEST OR INSPECTION**  
**CORRECTIVE ACTION**

---

**2. VEHICLE TURNS CORRECTLY IN ONE DIRECTION BUT NOT IN OTHER DIRECTION (CONTINUED).**

- Step 3. Check steering gear for oil leaks at fittings.
- If oil leaks are observed, tighten fittings.
  - If oil leaks are not observed, proceed to step 4.
- Step 4. Rotate steering wheel until vehicle is fully turned (articulated) left.
- With engine off, loosen two clamps and slide cylinder guard toward front of vehicle, and disconnect hose from elbow as shown.



**WARNING**

Keep hands and feet clear of steering cylinder assembly while checking for leakage. Failure to do so may cause serious injury.

- Start engine and hold steering wheel at full left turn position.
  - Check for hydraulic oil leakage from open steering cylinder elbow, then stop engine.
    - Hydraulic oil coming from open steering cylinder elbow indicates internal steering cylinder leakage. Replace steering cylinder assembly (WP 0173).
    - If hydraulic oil does not leak from open steering cylinder elbow, reconnect hose to elbow, reinstall clamps and cylinder guard, and proceed to step 5.
- Step 5. Rotate steering wheel until vehicle is fully turned (articulated) right.
- With engine off, loosen two clamps and slide cylinder guard toward front of vehicle, and disconnect hose from elbow as shown.

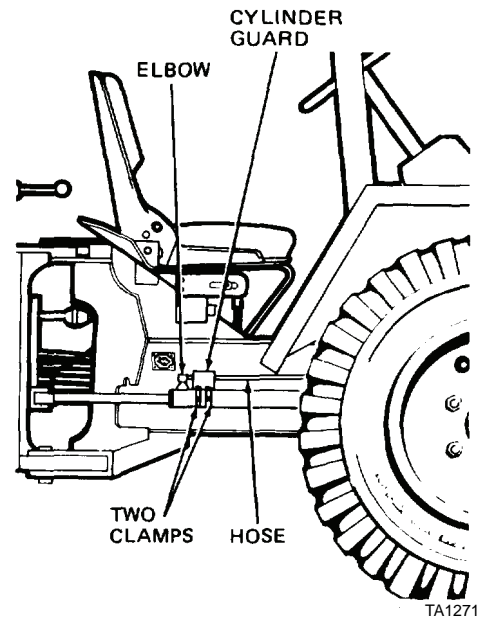

---

**MALFUNCTION**  
**TEST OR INSPECTION**  
**CORRECTIVE ACTION**

---

**2. VEHICLE TURNS CORRECTLY IN ONE DIRECTION BUT NOT IN OTHER DIRECTION (CONTINUED).**



**WARNING**

Keep hands and feet clear of steering cylinder assembly while checking for leakage. Failure to do so may cause serious injury.

- b. Start engine and hold steering wheel at full right turn position.
- c. Check for hydraulic oil leakage from open steering cylinder elbow, then stop engine.
  1. Hydraulic oil coming from open steering cylinder indicates internal steering cylinder leakage. Replace steering cylinder assembly (WP 0173).
  2. If hydraulic oil does not leak from open steering cylinder elbow, replace steering gear (notify Direct Support Maintenance).

**3. STEERING WHEEL TURNS HARD OR VEHICLE TURNS TOO SLOWLY.**

- Step 1. Check pressure in all tires (should be 45 PSI).
  - a. If tire pressure is not 45 PSI in all tires, adjust to 45 PSI.
  - b. If tire pressure is okay in all tires, proceed to step 2.
- Step 2. Check oil level in hydraulic reservoir. Oil level should be between FULL and ADD marks with mast lowered.
  - a. If oil level is not between FULL and ADD marks on dipstick with mast lowered, add oil (refer to LO 10-3930-638-12).
  - b. If oil level is okay, proceed to step 3.
- Step 3. Check steering cylinders for oil leaks at rod end.
  - a. If oil leaks are observed, replace steering cylinder.
  - b. If oil leaks are not observed, proceed to step 4.
- Step 4. Perform step 4 of MALFUNCTION 2 in this work package.
  - a. If hydraulic oil leaks from open steering cylinder elbow, replace steering cylinder assembly (WP 0173).
  - b. If hydraulic oil does not leak from open steering cylinder elbow, proceed to step 5.
- Step 5. Perform step 5 of MALFUNCTION 2 in this work package.
  - a. If hydraulic oil leaks from open steering cylinder elbow, replace steering cylinder assembly (WP 0173).
  - b. If hydraulic oil does not leak from open steering cylinder elbow, proceed to step 6.

---

**MALFUNCTION**  
**TEST OR INSPECTION**  
**CORRECTIVE ACTION**

---

**3. STEERING WHEEL TURNS HARD OR VEHICLE TURNS TOO SLOWLY (CONTINUED).**

- Step 6. Check pressure setting of relief valve (WP 0172, step 22).
- a. If pressure indication is not 2,500 to 2,550 PSI (17,237 to 17,582 kPa), adjust relief valve (WP 0172, step 23).
  - b. If pressure indication is 2,500 to 2,550 PSI (17,237 to 17,582 kPa), replace steering gear (notify Direct Support Maintenance).

**4. EFFORT TO TURN IN ONE DIRECTION IS MORE THAN REQUIRED IN OTHER DIRECTION.**

Check steering gear for internal wear/damage (notify Direct Support Maintenance).

Replace steering gear (notify Direct Support Maintenance).

**END OF WORK PACKAGE**

---

## ORGANIZATIONAL TROUBLESHOOTING PROCEDURES

### FRAME AND TOWING ATTACHMENTS TROUBLESHOOTING

---

MALFUNCTION
-------------

TEST OR INSPECTION
--------------------

CORRECTIVE ACTION
-------------------

---

#### 1. PINTLE HOOK STUCK.

Check pintle hook for obstruction, damage, or wear.

Replace pintle hook (WP 0176).

#### 2. LOUD CLUNK HEARD WHEN VEHICLE TURNS.

Inspect chassis stop bumper for damage or wear.

Replace chassis stop bumper (WP 0176).

#### 3. TOW BAR DOES NOT PIVOT OR LATCH.

Step 1. Check chassis where tow bar is attached for obstructions.

a. If obstructed, remove obstruction.

b. If not obstructed, proceed to step 2.

Step 2. Check chassis, tow bar, and mounting hardware for cracks or dents.

a. If tow bar is dented or cracked, replace (WP 0176).

b. If tow bar is okay, proceed to step 3.

Step 3. Check tow bar bracket for loose mounting, dents, or cracks.

Tighten mounting hardware; replace bracket if cracked or dented (WP 0176).

**END OF WORK PACKAGE**





---

# ORGANIZATIONAL TROUBLESHOOTING PROCEDURES

## BODY, CAB, AND HOOD TROUBLESHOOTING

---

### MALFUNCTION

### TEST OR INSPECTION

### CORRECTIVE ACTION

---

#### 1. SIDE PANEL DOES NOT LATCH.

- Step 1. Inspect side panel lock bracket on chassis for damage, dents, or missing condition. Check for loose mounting hardware.
- Replace side panel lock bracket (WP 0179), if damaged or dented; tighten loose mounting hardware.
  - If bracket is okay and hardware is tight, proceed to step 2.
- Step 2. Check side panel hook for damage, cracks, or missing condition. Check hook for unrestricted movement.
- If side panel hook is damaged, cracked, or missing, replace (WP 0179).
  - If side panel hook is okay, proceed to step 3 below.
- Step 3. Check side panels for damage or dents.  
Replace side panels if damaged or dented (WP 0179).

#### 2. SEAT WILL NOT ADJUST.

- Step 1. Check seat adjuster and immediate area for obstructions.
- If obstructions are present, remove.
  - If no obstructions are present, proceed to step 2.
- Step 2. Inspect adjuster lever and spring for cracks, damage, or missing condition.
- If adjuster lever and spring are cracked, missing, or damaged, replace (WP 0185) (Model 207).
  - If adjuster lever and spring are okay, proceed to step 3.
- Step 3. Inspect seat adjusters for distortion, damage, or misalignment.
- Replace if distorted, damaged, or misaligned (WP 0185) (Model 207).
  - Replace seat if distorted, damaged, or misaligned (WP 0186) (Model 4-390).
  - If seat adjusters are okay, check seat adjuster mounting hardware for looseness or missing condition. Tighten or replace mounting hardware (WP 0185 or WP 0186).

**END OF WORK PACKAGE**



---

## ORGANIZATIONAL TROUBLESHOOTING PROCEDURES

### HYDRAULIC LIFT SYSTEM TROUBLESHOOTING

---

MALFUNCTION
TEST OR INSPECTION
CORRECTIVE ACTION

---

#### NOTE

Also refer to WP 0190, *Hydraulic Lift System Operational Test*, for additional troubleshooting data.

#### 1. LOAD LOWERS TOO FAST.

- Step 1. Check hoses, lines, and fittings between control valve and lift cylinder assembly for oil leaks.
  - a. If oil leakage is observed, tighten fittings; if hoses or lines are damaged, replace (WP 0195).
  - b. If oil leakage is not observed, proceed to step 2.
  
- Step 2. Lower mast assembly to ground.
  - a. Turn engine off and relieve hydraulic pressure by operating control levers several times.
  - b. Place container under lift cylinder to catch hydraulic oil.
  - c. Loosen and disconnect fitting at lift cylinder port; remove elbow.
  - d. Ensure restrictor is properly installed: FLOW arrow marked on restrictor pointing towards lift cylinder assembly.
    - 1. If restrictor is not installed properly, install properly.
    - 2. If restrictor is installed properly and problem still exists, replace restrictor.

#### 2. LOAD CREEPS DOWNWARD.

- Step 1. Check hoses, lines, and fittings between control valve and lift cylinder assembly for oil leaks.
  - a. If oil leakage is observed, tighten fittings; if hoses or lines are damaged, replace (WP 0195).
  - b. If oil leakage is not observed, proceed to step 2.
  
- Step 2. Check if lift cylinder assembly requires bleeding of air (WP 0195, step 27).
  - a. Bleed air from lift cylinder assembly (WP 0195, step 27).
  - b. If lift cylinder does not require bleeding of air, proceed to step 3.
  
- Step 3. Perform step 2 of MALFUNCTION 1 in this work package.
 

Same as step 2 of MALFUNCTION 1 in this work package.

---

MALFUNCTION	TEST OR INSPECTION	CORRECTIVE ACTION
-------------	--------------------	-------------------

---

### 3. UNABLE TO LIFT, TILT, SHIFT, OR ROTATE LOAD.

- Step 1. Check hydraulic reservoir oil level.
- If oil level is not between FULL and ADD marks on dipstick with mast lowered, add hydraulic oil (refer to LO 10-3930-698-12).
  - If oil level is okay, proceed to step 2.
- Step 2. Start engine and operate control levers while observing hydraulic filter indicator light on instrument panel.
- If hydraulic filter indicator is lit, replace hydraulic oil filter (WP 0199).
  - If hydraulic indicator is not lit, turn engine off, place ignition switch in lamp test position and ensure hydraulic filter indicator is on. If hydraulic filter indicator is on, proceed to step 3. If hydraulic filter indicator is not on, replace bulb (WP 0108), and repeat this step.
- Step 3. Remove strainer from hydraulic reservoir and check for blockage (WP 0200).
- If hydraulic reservoir strainer is clogged, clean (WP 0200).
  - If hydraulic reservoir strainer is okay, proceed to step 4.
- Step 4. Check setting of relief valve (WP 0172, step 20).
- Adjust pressure relief valve if setting is not 2,500 to 2,550 PSI (17,237 to 17,582 kPa) (WP 0172, step 23).
  - If pressure relief valve setting is okay, proceed to step 5.
- Step 5. Check for contaminated oil.
- Start engine and operate at idle speed.
  - Place lift control lever in RAISE position and hold until tube located as shown feels warm to touch (mast will be at full height).
  - Remove hydraulic reservoir oil filter and take an oil sample:
- If hydraulic oil is contaminated as indicated by oil feeling gritty, having a milky color, or oil being dark and thick or smelling scorched, drain and flush hydraulic system, clean strainer, and replace oil filter (WP 0198, WP 0199, and WP 0200).

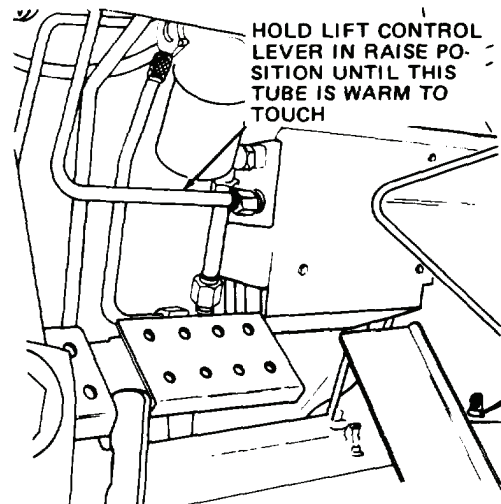

TA127040

---

**MALFUNCTION**  
**TEST OR INSPECTION**  
**CORRECTIVE ACTION**

---

**4. LIFT, TILT, SHIFT, OR ROTATE TOO SLOW.**

- Step 1. Check hoses, lines, and fittings between hydraulic reservoir, pump, and control valve for oil leaks.
- If oil leakage is observed, tighten fittings; if hoses or lines are damaged, replace (WP 0195).
  - If oil leakage is not observed, proceed to step 2.
- Step 2. Check setting of relief valve (WP 0172, step 20).
- Adjust pressure relief valve if setting is not 2,500 to 2,550 PSI (17,237 to 17,582 kPa) (WP 0172, step 23).
  - If pressure relief valve setting is okay, proceed to step 3.
- Step 3. Check hydraulic reservoir oil level.
- If oil level is not between FULL and ADD marks on dipstick with mast lowered, add hydraulic oil (refer to LO 10-3930-698-12).
  - If oil level is okay, proceed to step 4.
- Step 4. Perform WP 0190.  
Same as in WP 0190.

**5. LOAD CREEPS WHILE TILTING.**

- Step 1. Check hoses, lines, and fittings between control valve and tilt cylinder assembly for oil leaks.
- If oil leakage is observed, tighten fittings; if hoses or lines are damaged, replace (WP 0195).
  - If oil leakage is not observed, proceed to step 2.
- Step 2. Perform step 4 of WP 0190.  
Same as steps 5 and 6 of WP 0190.

**END OF WORK PACKAGE**



---

# ORGANIZATIONAL TROUBLESHOOTING PROCEDURES

## GAGES TROUBLESHOOTING

---

### MALFUNCTION

### TEST OR INSPECTION

### CORRECTIVE ACTION

---

#### 1. ENGINE OIL PRESSURE GAGE DOES NOT INDICATE CORRECT PRESSURE.

- Step 1. Place ignition switch in ON position.  
Oil pressure gage should indicate zero.
- a. If zero indication not obtained, proceed to step 2.
  - b. If zero indication obtained, proceed to step 3.
- Step 2. Disconnect wire from oil pressure sender.  
Oil pressure gage should indicate zero.
- a. If oil pressure gage indicates 80 (full scale), repair or replace short circuited wire. Proceed to step 3.
  - b. If oil pressure gage indicates zero, replace oil pressure sender.
  - c. If oil pressure gage indicates other than zero or 80 (full scale), replace oil pressure gage (WP 0203).
- Step 3. Temporarily connect jumper wire between oil pressure gage SENDER terminal and chassis ground.  
Place ignition switch in ON position.  
Oil pressure gage should indicate 80 (full scale).
- a. If 80 (full scale) indication not obtained, proceed to step 4.
  - b. If 80 (full scale) indication obtained, disconnect wire and proceed to step 5.
  - c. If oil pressure gage indicates other than zero or 80 (full scale), replace oil pressure gage (WP 0203).
- Step 4. Check for +24 VDC between oil pressure gage IGN terminal and ground (ignition switch in ON position).
- a. If +24 VDC not obtained, troubleshoot electrical system (WP 0005).
  - b. If +24 VDC obtained, disconnect jumper wire between oil pressure gage SENDER terminal and ground, and replace oil pressure gage (WP 0203).
- Step 5. Disconnect wire from oil pressure sending unit.
- a. Temporarily ground wire while assistant observes oil pressure gage.
  - b. Oil pressure gage should indicate 80 (full scale).
- Repair or replace broken wire (notify Direct Support Maintenance).

---

**MALFUNCTION**  
**TEST OR INSPECTION**  
**CORRECTIVE ACTION**

---

**2. FUEL GAGE DOES NOT REGISTER.**

Step 1. If fuel gage indicates E, disconnect wire at fuel gage sender and ground wire to chassis.

- a. Place ignition switch in ON position.
- b. Fuel gage should indicate F.
- c. Temporarily ground wire while assistant observes oil pressure gage.
- d. Oil pressure gage should indicate 80 (full scale).
  1. If fuel gage indicates F, replace fuel gage sender (WP 0117).
  2. If fuel gage indicates E, proceed to step 2.
  3. If fuel gage indicates other than F or E, replace (WP 0203).

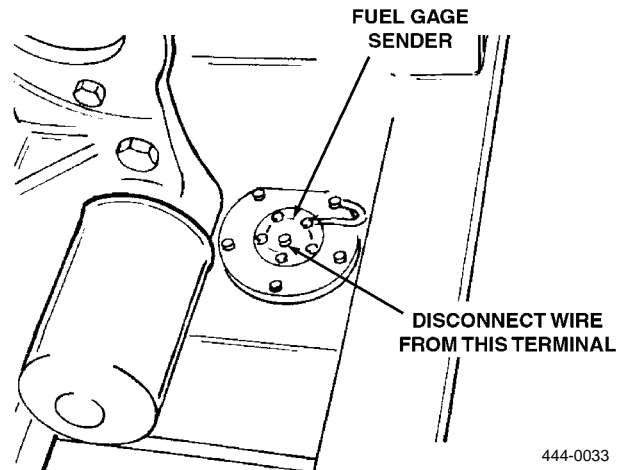

444-0033

Step 2. Check for +24 VDC at fuel gage IGN terminal (ignition switch in ON position).

- a. If +24 VDC not obtained, troubleshoot electrical system (WP 0008).
- b. If +24 VDC obtained, replace fuel gage (WP 0203).

Step 3. If fuel gage indicates F, disconnect wire at fuel gage sender.

Repair or replace broken wire (notify Direct Support Maintenance).

- a. If +24 VDC not obtained, troubleshoot electrical system (WP 0008).
- b. If +24 VDC obtained, replace fuel gage (WP 0203).

**3. FUEL GAGE DOES NOT INDICATE CORRECT FUEL LEVEL.**

Disconnect wire at fuel gage SENDER terminal and connect a 2-foot length of no. 22 AWG insulated wire to this terminal.

- a. Obtain a 1K Ohm variable resistor and connect one end to other end of wire connected to fuel gage SENDER terminal.
- b. Connect center terminal of 1K Ohm variable resistor to ground.
- c. Place ignition switch in ON position.
- d. Adjust variable resistor until fuel gage indicates 1/4 E, turn ignition switch OFF, and measure and note resistance of variable resistor using an ohmmeter.
- e. Turn ignition switch ON and repeat this procedure for 1/2 and 3/4 F fuel gage indications.
  1. Replace fuel gage if resistance readings are not within  $22 \pm 2$ ,  $44 \pm 4$ ,  $66 \pm 6$  Ohms for 1/4 E, 1/2, and 3/4 fuel gage indications.
  2. Replace fuel gage sender if resistance readings are within above values.

**END OF WORK PACKAGE**



**CHAPTER 3**  
**DIRECT SUPPORT TROUBLESHOOTING PROCEDURES**



---

# DIRECT SUPPORT TROUBLESHOOTING PROCEDURES

## DIRECT SUPPORT TROUBLESHOOTING INTRODUCTION

---

### INTRODUCTION

1. Troubleshooting procedures in this chapter contain information you need to locate fault malfunctions on the MHE 237 Forklift Truck and its components.
2. A *Troubleshooting Symptom Index* in WP 0029 is provided to aid in locating a malfunction or symptom and directs you to the appropriate troubleshooting procedure.
3. Troubleshooting procedures in this manual cannot provide all the answers or correct all malfunctions encountered. However, these procedures are an organized step-by-step approach to a problem that provide tests and inspections toward the source of the problem and its successful resolution.
4. If a malfunction is not listed in the *Troubleshooting Symptom Index* in WP 0029, or stated tests or inspections and corrective actions do not correct the problem, notify your supervisor.
5. Before performing troubleshooting, read and follow all safety instructions found in the *Warning Summary* at the front of this manual.

### EXPLANATION OF TROUBLESHOOTING TABLE COLUMNS

The columns in the tables in each troubleshooting work package are defined as follows:

1. **MALFUNCTION**. A visual or operational indication that something is wrong with the equipment.
2. **TEST OR INSPECTION**. A procedure to isolate the problem in a system or component.
3. **CORRECTIVE ACTION**. A procedure to correct the problem.

### END OF WORK PACKAGE



# DIRECT SUPPORT TROUBLESHOOTING PROCEDURES

## DIRECT SUPPORT TROUBLESHOOTING SYMPTOM INDEX

<u>Malfunction/Symptom</u>	<u>Troubleshooting Procedure Page</u>
<b>Engine (Model 207)</b>	
1 Engine Hard to Start or Will Not Start. . . . .	.0030-1
2 Engine Hard to Start or Will Not Start (Exhaust Smoke). . . . .	.0030-1
3 Engine Starts But Will Not Run. . . . .	.0030-2
4 Engine Misfires. . . . .	.0030-2
5 Engine Stalls Frequently or Does Not Develop Full Power. . . . .	.0030-3
6 Engine Knocks. . . . .	.0030-3
7 Engine Compression Test. . . . .	.0030-4
<b>Engine (Model 4-390)</b>	
1 Engine Hard to Start or Will Not Start. . . . .	.0031-1
2 Engine Hard to Start or Will Not Start (Exhaust Smoke). . . . .	.0031-1
3 Engine Starts But Will Not Run. . . . .	.0031-1
4 Engine Misfires. . . . .	.0031-2
5 Engine Stalls Frequently or Does Not Develop Full Power. . . . .	.0031-2
6 Engine Knocks. . . . .	.0031-3
7 Engine Compression Test. . . . .	.0031-4
<b>Fuel System (Model 207)</b>	
1 Engine Idle Speed Incorrect. . . . .	.0032-1
2 Engine No-load Governed Speed Incorrect. . . . .	.0032-1
3 Engine Hard to Start. . . . .	.0032-1
4 Engine Starts and Stops. . . . .	.0032-4
5 Erratic Engine Operation (Surge, Misfiring, Poor Governor Regulation). . . . .	.0032-5
6 Engine Idles Imperfectly. . . . .	.0032-7
7 Engine Does Not Develop Full Power or Speed. . . . .	.0032-9
8 Engine Smokes Black. . . . .	.0032-12
9 Engine Smokes Blue or White. . . . .	.0032-12
10 Fuel Not Reaching Fuel Injection Pump. . . . .	.0032-13
11 Fuel Delivered From Transfer Pump But Not to Fuel Injectors. . . . .	.0032-13
12 Fuel Reaching Fuel Injectors but Engine Will Not Start. . . . .	.0032-15
<b>Fuel System (Model 4-390)</b>	
1 Engine Idle Speed Incorrect. . . . .	.0033-1
2 Engine No-load Governed Speed Incorrect. . . . .	.0033-1
3 Engine Hard To Start. . . . .	.0033-1
4 Engine Starts And Stops. . . . .	.0033-1
5 Erratic Engine Operation (Surge, Misfiring, Poor Governor Regulation). . . . .	.0033-2
6 Engine Idles Imperfectly. . . . .	.0033-2
7 Engine Does Not Develop Full Power or Speed. . . . .	.0033-2

8 Engine Smokes Black.....0033-2

**Malfunction/Symptom** **Troubleshooting Procedure Page**

**Fuel System (Model 4-390) - Continued**

9 Engine Smokes Blue or White.....0033-3  
 10 Fuel Reaching Fuel Injectors but Engine Will Not Start.....0033-3

**Alternator**

1 Improper Output Voltage.....0034-1  
 2 Improper Output Current.....0034-3

**Starter and Solenoid**

1 Starter Troubleshooting.....0035-1  
 2 Starter Fails to Crank.....0035-2

**Wiring Harness (Model 207)**

1 Major Portion of Electrical System Inoperative.....0036-1  
 2 One Electrical Circuit Inoperative.....0036-1

**Wiring Harness (Model 4-390)**

1 Major Portion of Electrical System Inoperative.....0037-1  
 2 One Electrical Circuit Inoperative.....0037-1

**Transmission**

1 High Transmission Oil Temperature.....0038-1  
 2 Loss of Drive in All Ranges.....0038-1  
 3 Loss of Power and/or Loss of Drive in Any One Range.....0038-2

**Axes and Differential Carrier Assemblies**

1 Continuous Axle or Wheel Noise.....0039-1  
 2 Lubricant Leaking From Differential Carrier Assembly.....0039-1

**Hydraulic Pump**

1 Vehicle Will Not Turn When Steering Wheel is Turned.....0040-1  
 2 Hydraulic Oil Foaming.....0040-1  
 3 Excessive Hydraulic Pump Noise.....0040-1

**Steering Column and Cylinder**

1 Effort to Turn in One Direction is More Than Required in Other Direction.....0041-1  
 2 Steering Wheel Turns Hard in Both Directions.....0041-1

**Chassis**

1 Excessive Noise at Chassis Pivot Point When Turning.....0042-1  
 2 Excessive Play at Chassis Pivot Point When Turning.....0042-1

**Malfunction/Symptom**

**Troubleshooting Procedure Page**

**Hydraulic Lift System**

1	Unable to Lift a Load (All Other Functions Normal).....	.0043-1
2	Load Drifts Down.....	.0043-4
3	Unable to Sideshift Load (All Other Functions Normal).....	.0043-4
4	Sideshift Cylinder Assembly Operation Sluggish.....	.0043-6
5	Unable to Tilt Load (All Other Functions Normal).....	.0043-7
6	Tilt Cylinder Assemblies Operation Sluggish.....	.0043-9
7	Unable to Rotate Load (All Other Functions Normal).....	.0043-9
8	Rotation Operation Sluggish.....	.0043-11

**END OF WORK PACKAGE**





---

## DIRECT SUPPORT TROUBLESHOOTING PROCEDURES

### ENGINE TROUBLESHOOTING (MODEL 207)

---

**MALFUNCTION****TEST OR INSPECTION****CORRECTIVE ACTION**

---

**1. ENGINE HARD TO START OR WILL NOT START.**

- Step 1. Check for correct valve timing in reference to crankshaft timing marks with dial indicator (WP 0204, step 2).
- If valve timing is correct, proceed to step 2.
  - If valve timing is not correct, check for sheared key in cam drive gear or a broken camshaft (notify General Support Maintenance) (WP 0282).
- Step 2. Perform compression test of each cylinder (MALFUNCTION 7 in this work package).
- If compression test is satisfactory, check for sheared roll pin on fuel injection pump drive shaft (WP 0233) or defective fuel injection pump (notify General Support Maintenance) (WP 0289).

**2. ENGINE HARD TO START OR WILL NOT START (EXHAUST SMOKE).**

- Step 1. Check for proper engine timing (WP 0204).
- If engine timing is correct, proceed to step 2.
  - If engine timing is not correct, adjust timing (WP 0204).
- Step 2. Perform compression test of each cylinder (MALFUNCTION 7 in this work package).
- If compression test is satisfactory, test fuel injector nozzles before reinstalling on engine (notify General Support Maintenance) (WP 0288). If fuel injector test is satisfactory, proceed to step 3.
- Step 3. Start engine and listen for excessive valve tappet noise.
- If excessive valve tappet noise is heard, stop engine and check for bent push rods (WP 0224).

---

**MALFUNCTION**  
**TEST OR INSPECTION**  
**CORRECTIVE ACTION**

---

**3. ENGINE STARTS BUT WILL NOT RUN.**

- Step 1. Check for proper fuel injection pump timing (WP 0208).
- If fuel injection pump timing is not correct, adjust timing (WP 0208).
  - If fuel injection pump timing is okay, proceed to step 2.
- Step 2. Check for correct valve timing in reference to crankshaft timing marks with dial indicator (WP 0204, step 2).
- If correct valve timing in reference to crankshaft timing marks is not obtained, check for sheared key in cam drive gear or a broken camshaft (notify General Support Maintenance) (WP 0282).
  - If correct valve timing in reference to crankshaft timing marks is obtained, proceed to step 3.
- Step 3. Perform compression test of each cylinder (MALFUNCTION 7 in this work package).
- If compression test is satisfactory, test fuel injector nozzles before reinstalling on engine (notify General Support Maintenance) (WP 0289). If fuel injector test is satisfactory, proceed to step 4.
- Step 4. Start engine and listen for excessive valve tappet noise.
- If excessive valve tappet noise is heard, stop engine and check for bent push rods (WP 0224).

**4. ENGINE MISFIRES.**

- Step 1. Remove fuel injectors (WP 0231) and check for damaged fuel injector nozzle seal.
- If fuel injector nozzle seal is damaged, replace (notify General Support Maintenance) (WP 0288).
  - If fuel injection seals are okay, proceed to step 2.
- Step 2. Check for proper fuel injection pump timing (WP 0208).
- If fuel injection pump timing is not correct, adjust timing (WP 0208).
  - If fuel injection pump timing is okay, proceed to step 3.
- Step 3. Check for correct valve timing in reference to crankshaft timing marks with dial indicator (WP 0204, step 2).
- If correct valve timing in reference to crankshaft timing marks is not obtained, check for sheared key in cam drive gear or a broken camshaft (notify General Support Maintenance) (WP 0282).
  - If correct valve timing in reference to crankshaft timing marks is obtained, proceed to step 4.
- Step 4. Perform compression test of each cylinder (MALFUNCTION 7 in this work package).
- If compression test is satisfactory, test fuel injector nozzle before reinstalling on engine (notify General Support Maintenance) (WP 0288). If fuel injector test is satisfactory, proceed to step 5.
- Step 5. Start engine and listen for excessive valve tappet noise.
- If excessive valve tappet noise is heard, stop engine and check for bent push rods (WP 0224).

---

**MALFUNCTION**  
**TEST OR INSPECTION**  
**CORRECTIVE ACTION**

---

**5. ENGINE STALLS FREQUENTLY OR DOES NOT DEVELOP FULL POWER.**

- Step 1. Check for proper engine timing and valve tappet clearance adjustment (WP 0204).
- a. If engine timing and valve tappet clearance adjustment is not okay, adjust (WP 0204).
  - b. If engine timing and valve tappet clearance adjustment is okay, proceed to step 2.
- Step 2. Check fuel injection pump timing and speed adjustments (WP 0208).
- a. If fuel injection pump timing and speed adjustments are not okay, adjust (WP 0208).
  - b. If fuel injection pump timing and speed adjustments are okay, proceed to step 3.
- Step 3. Perform compression test of each cylinder (MALFUNCTION 7 in this work package).
- If compression test is satisfactory, test fuel injector nozzles before reinstalling on engine (notify General Support Maintenance) (WP 0288). If fuel injector test is satisfactory, check for camshaft installed one tooth out of time or a defective fuel injection pump (notify General Support Maintenance) (WP 0282 or WP 0289).

**6. ENGINE KNOCKS.**

- Step 1. Start engine and listen for chucking or pounding sound at low speed, which disappears as engine speed is increased.
- a. If chucking or pounding sound is heard at low speed and disappears as engine speed is increased, check flywheel for looseness or damage (notify General Support Maintenance) (WP 0278).
  - b. If chucking or pounding sound is not heard, proceed to step 2.
- Step 2. Start engine and listen for a sharp metallic sound which increases as engine speed increases. Crack (open) injector line to each cylinder, one at a time, to check if knock stops or decreases.
- a. If the knock stops or decreases, check for defective rod bearing on affected cylinder (notify General Support Maintenance) (WP 0280).
  - b. If the knock increases, check for defective piston pin (notify General Support Maintenance) (WP 0288).
  - c. If knock is not heard, proceed to step 3.
- Step 3. Start engine and listen for a thudding sound which increases as engine speed increases.
- a. If thudding sound is heard which increases as engine speed increases, check main bearings for wear or damage (notify General Support Maintenance) (WP 0283).
  - b. If thudding sound is not heard, proceed to step 4.
- Step 4. Start engine and listen for one thudding sound when increasing engine speed and one thud when decreasing speed.
- Check camshaft and crankshaft for excessive end play (notify General Support Maintenance) (WP 0282 and WP 0276).

---

MALFUNCTION	TEST OR INSPECTION	CORRECTIVE ACTION
-------------	--------------------	-------------------

---

### 7. ENGINE COMPRESSION TEST.

Remove fuel injectors, and clean fuel injector bores in cylinder head (WP 0276).

- a. Install D-558 compression gage adapter (FSCM 05083 P/N 70-314) in fuel injector bore at No. 4 cylinder, and secure with clamp assembly and spacer as shown.
- b. Connect compression gage (FSCM 10988 P/N CD-504) to adapter, crank engine with starter, and record gage reading.
- c. Depress vent button to relieve gage pressure and repeat test.

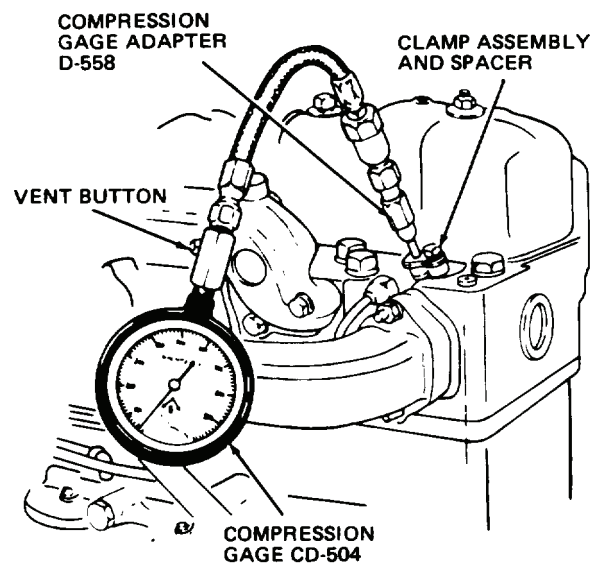

TA127078

### NOTE

Engine cranking speed must be approximately 200 RPM for reliable test results. If necessary, charge batteries to maintain proper cranking speed.

- d. Disconnect compression gage and adapter from No. 4 cylinder and repeat above test at remaining three cylinders.
- e. The gage reading for any one cylinder at a given altitude above sea level must not be less than the minimum listed in Table 1.
- f. In addition, the difference between gage readings for the highest and lowest cylinders should not exceed 25 PSI (172 kPa).

**MALFUNCTION**  
**TEST OR INSPECTION**  
**CORRECTIVE ACTION**

**7. ENGINE COMPRESSION TEST (CONTINUED).**

**Table 1. Cylinder Compression Test Chart.**

<b>MINIMUM COMPRESSION PRESSURE AT 200 RPM (PSI)</b>	<b>ALTITUDE ABOVE SEAL LEVEL (FEET)</b>
400	0
384	1000
360	2500
320	5000
280	7500
240	10000

1. If compression is high, remove cylinder head and check for carbon deposits on cylinder head and piston crown (WP 0218). Also, check (using micrometer) if too much material was removed from resurfaced cylinder head (cylinder head minimum thickness is 3.968 inches) (notify General Support Maintenance) (WP 0272).
2. If compression is low, squirt a teaspoon of engine oil into the affected cylinder and repeat compression test. If compression gage reading increases to near normal, remove cylinder head (WP 0218) and check piston rings and sleeves (notify General Support Maintenance) (WP 0280 and WP 0270).
3. If compression gage reading remains low after squirting oil in cylinder, remove cylinder head (WP 0218) and check for blown head gasket. If gasket is not damaged, check for burned or damaged valves and valve seats (notify General Support Maintenance) (WP 0289).
4. If compression is low, and items in steps (2) and (3) above check satisfactorily, check for head gasket leakage due to excessive piston sleeve protrusion (notify General Support Maintenance) (WP 0290).

**END OF WORK PACKAGE**



---

## DIRECT SUPPORT TROUBLESHOOTING PROCEDURES

### ENGINE TROUBLESHOOTING (MODEL 4-390)

---

MALFUNCTION
TEST OR INSPECTION
CORRECTIVE ACTION

#### 1. ENGINE HARD TO START OR WILL NOT START.

- Step 1. Check for correct engine timing (WP 0205).
- a. If engine timing is correct, proceed to step 2.
  - b. If engine timing is not correct, check for sheared key in the cam drive gear or a broken camshaft (WP 0283) (notify General Support Maintenance).
- Step 2. Perform compression test of each cylinder (MALFUNCTION 7 in this work package).  
If compression test is satisfactory, replace fuel injection pump (WP 0234).

#### 2. ENGINE HARD TO START OR WILL NOT START (EXHAUST SMOKE).

- Step 1. Check for correct engine timing (WP 0205).
- a. If engine timing is correct, proceed to step 2.
  - b. If engine timing is not correct, adjust timing (WP 0205).
- Step 2. Perform compression test of each cylinder (MALFUNCTION 7 in this work package).  
If compression test is satisfactory, replace fuel injectors (WP 0232).
- Step 3. Again attempt to start engine. If engine starts, listen for excessive valve tappet noise.  
If excessive valve tappet noise is heard, stop engine and check for bent push rods (WP 0225).

#### 3. ENGINE STARTS BUT WILL NOT RUN.

- Step 1. Check for correct fuel injection pump timing (WP 0234).
- a. If fuel injection pump timing is not correct, adjust timing (WP 0234).
  - b. If fuel injection pump timing is correct, proceed to step 2.
- Step 2. Check for correct engine timing (WP 0205).
- a. If engine timing is not correct, check for sheared key in cam drive gear or a broken camshaft (WP 0283) (notify General Support Maintenance).
  - b. If engine timing is correct, proceed to step 3.
- Step 3. Perform compression test of each cylinder (MALFUNCTION 7 in this work package).  
If compression test is satisfactory, replace fuel injectors (WP 0232).
- Step 4. Start engine and listen for excessive valve tappet noise.  
If excessive valve tappet noise is heard, stop engine and check for bent push rods (WP 0232).

---

**MALFUNCTION**  
**TEST OR INSPECTION**  
**CORRECTIVE ACTION**

---

**4. ENGINE MISFIRES.**

- Step 1. Remove fuel injectors (WP 0232) and check for damaged fuel injector nozzle seal.
- If fuel injector nozzle seal is damaged, replace fuel injector (WP 0232).
  - If fuel injection seals are okay, proceed to step 2.
- Step 2. Check for proper fuel injection pump timing (WP 0234).
- If fuel injection pump timing is not correct, adjust timing (WP 0234).
  - If fuel injection pump timing is correct, proceed to step 3.
- Step 3. Check for correct engine timing (WP 0205).
- If engine timing is not correct, check for sheared key in cam drive gear or a broken camshaft (WP 0283) (notify General Support Maintenance).
  - If engine timing is correct, proceed to step 4.
- Step 4. Perform compression test of each cylinder (MALFUNCTION 7 in this work package).  
If compression test is satisfactory, replace fuel injectors (WP 0232).
- Step 5. Start engine and listen for excessive valve tappet noise.  
If excessive valve tappet noise is heard, stop engine and check for bent push rods (WP 0225).

**5. ENGINE STALLS FREQUENTLY OR DOES NOT DEVELOP FULL POWER.**

- Step 1. Check for correct engine timing and valve tappet clearance adjustment (WP 0205 and WP 0206).
- If engine timing and valve tappet clearance adjustment is not correct, adjust (WP 0205 and WP 0206).
  - If engine timing and valve tappet clearance adjustment is correct, proceed to step 2.
- Step 2. Check fuel injection pump timing (WP 0234).
- If fuel injection pump timing and is not correct, adjust (WP 0234).
  - If fuel injection pump timing is correct, proceed to step 3.
- Step 3. Perform compression test of each cylinder (MALFUNCTION 7 in this work package).
- If compression test is satisfactory, replace fuel injectors (WP 0232).
  - If condition is not corrected, check for camshaft installed one tooth out of time (WP 0273) or replace defective fuel injection pump (WP 0234).



---

**MALFUNCTION**  
**TEST OR INSPECTION**  
**CORRECTIVE ACTION**

---

**6. ENGINE KNOCKS.**

- Step 1. Start engine and listen for chucking or pounding sound at low speed, which disappears as engine speed is increased.
- If chucking or pounding sound is heard at low speed and disappears as engine speed is increased, check flywheel for looseness or damage (WP 0275) (notify General Support Maintenance).
  - If chucking or pounding sound is not heard, proceed to step 2.
- Step 2. Start engine and listen for a sharp metallic knock sound which increases as engine speed increases. Crack (open) injector line to each cylinder, one at a time, to check if knock stops or decreases.
- If knock stops or decreases, check for defective rod bearing on affected cylinder (WP 0281) (notify General Support Maintenance).
  - If the knock increases, check for defective piston pin (WP 0281) (notify General Support Maintenance).
  - If knock is not heard, proceed to step 3.
- Step 3. Start engine and listen for a thudding sound which increases as engine speed increases.
- If thudding sound is heard which increases as engine speed increases, check main bearing for wear or damage (WP 0277) (notify General Support Maintenance).
  - If thudding sound is not heard, proceed to step 4.
- Step 4. Start engine and listen for one thudding sound when increasing engine speed and one thud when decreasing speed.
- Check camshaft and crankshaft for excessive end play (WP 0283) (notify General Support Maintenance).

**MALFUNCTION**  
**TEST OR INSPECTION**  
**CORRECTIVE ACTION**

**7. ENGINE COMPRESSION TEST.**

Remove fuel injectors and clean fuel injector bores in cylinder head (WP 0232).

- a. Install D-5587 compression gage adapter (FSCM 05083 P/N 70-314) in fuel injector bore at No. 4 cylinder, and secure with clamp assembly and spacer as shown.
- b. Connect compression gage (FSCM 10988 P/N CD-504) to adapter, crank engine with starter, and record gage reading.
- c. Depress vent button to relieve gage pressure and repeat test.

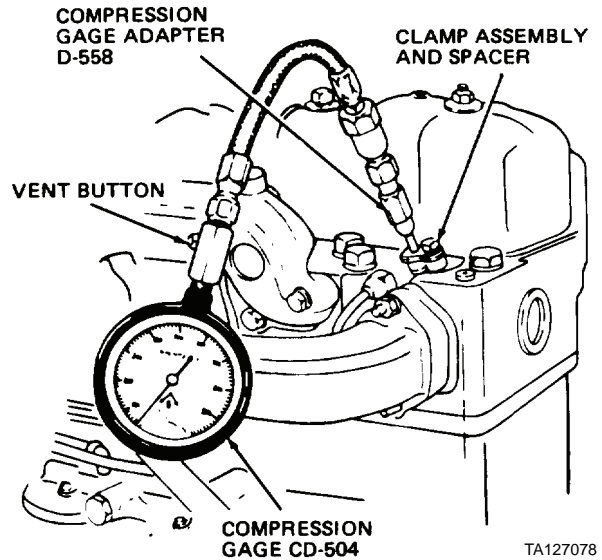

**NOTE**

- Engine cranking speed must be approximately 200 RPM for reliable test results. If necessary, charge batteries to maintain proper cranking speed.
- Disconnect compression gage and adapter from No. 4 cylinder and repeat above test at remaining three cylinders.
- The gage reading for any one cylinder at a given altitude above sea level must not be less than the minimum listed in Table 1. The difference between gage readings for the highest and lowest cylinders should not exceed 25 PSI.

**Table 1. Cylinder Compression Test Chart.**

MINIMUM COMPRESSION PRESSURE AT 200 RPM (PSI)	ALTITUDE ABOVE SEA LEVEL (FEET)
400	0
384	1000
360	2500
320	5000
280	7500
240	10000

---

**MALFUNCTION**  
**TEST OR INSPECTION**  
**CORRECTIVE ACTION**

---

**7. ENGINE COMPRESSION TEST (CONTINUED).**

1. If compression is high, remove cylinder head and check for carbon deposits on cylinder head and piston crown (WP 0219). Also, check (using micrometer) if too much material was removed from resurfaced cylinder head. Cylinder head minimum thickness is 3.691 in. Refer to WP 0273 (notify General Support Maintenance).
2. If compression is low, squirt a teaspoon of engine oil into the affected cylinder and repeat compression test. If compression gage reading increases to near normal, remove cylinder head (WP 0219) and check piston rings and sleeves (WP 0281) (notify General Support Maintenance).
3. If compression gage reading remains low after squirting oil in cylinder, remove cylinder head (WP 0219) and check for blown head gasket. If gasket is not damaged, check for burned or damaged valves and valve seats (WP 0273) (notify General Support Maintenance).
4. If compression is low, and items in steps (2) and (3) above check satisfactorily, check for head gasket leakage due to excessive piston sleeve protrusion (WP 0271) (notify General Support Maintenance).

**END OF WORK PACKAGE**



---

## DIRECT SUPPORT TROUBLESHOOTING PROCEDURES

### FUEL SYSTEM TROUBLESHOOTING (MODEL 207)

---

**MALFUNCTION****TEST OR INSPECTION****CORRECTIVE ACTION**

---

**1. ENGINE IDLE SPEED INCORRECT.**

Perform fuel injection pump timing and idle speed adjustments (WP 0208).

- a. If idle speed screw on injection pump does not vary engine speed, replace fuel injection pump (WP 0233).
- b. If idle speed screw on injection pump changes engine speed, but will not adjust to correct value, check accelerator linkage (WP 0074). If accelerator linkage checks satisfactory, check fuel pressure (WP 0007) and fuel injectors (WP 0231). If above checks are satisfactory, replace fuel injection pump (WP 0233).

**2. ENGINE NO-LOAD GOVERNED SPEED INCORRECT.**

Perform fuel injection pump timing and no-load governed speed adjustments (WP 0208).

- a. If high speed screw on injection pump does not vary engine speed, replace fuel injection pump (WP 0233).
- b. If high speed screw on injection pump varies engine speed, but will not reduce speed to correct value (no-load speed too high), replace fuel injection pump (WP 0233).
- c. If high speed screw on injection pump varies engine speed, but will not increase speed to correct value (no-load speed too low), check accelerator linkage (WP 0074), fuel pressure (WP 0007), and fuel injectors WP 0231). If above checks are satisfactory, replace fuel injection pump (WP 0233).

**3. ENGINE HARD TO START.**

Step 1. Check fuel injection pump timing (WP 0208).

- a. If fuel injection pump timing is not correct, adjust timing as described in WP 0208.
- b. If fuel injection pump timing is okay, proceed to step 2.

Step 2. Disconnect fuel lines from fuel injection pump at fuel injectors (WP 0229) one at a time, crank engine and ensure fuel is pumped out of disconnected line.

- a. If fuel is not pumped out of any one disconnected line when engine is cranked, replace associated connector screw (WP 0289; notify General Support Maintenance). If fuel is not pumped out of any line when disconnected, replace/clean inlet strainer (WP 0289; notify General Support Maintenance).
- b. If fuel is cranked out of all lines when disconnected, proceed to step 3.

Step 3. Disassemble fuel injection pump and check transfer pump blades for wear or damage (WP 0289, notify General Support Maintenance).

- a. If transfer pump blades are worn or damaged, replace (WP 0289).
- b. If transfer pump blades check okay, proceed to step 4.

---

**MALFUNCTION**  
**TEST OR INSPECTION**  
**CORRECTIVE ACTION**

---

**3. ENGINE HARD TO START (CONTINUED).**

- Step 4. Disassemble fuel injection pump and check transfer pump parts for wear or damage (WP 0289; notify General Support Maintenance).
- If transfer pump parts are worn or damaged, replace (WP 0289).
  - If transfer pump parts check okay, proceed to step 5.
- Step 5. Disassemble fuel injection pump and check end plate regulating piston and sleeve and inspect for burrs, corrosion, or varnishes (WP 0289; notify General Support Maintenance).
- If regulating piston and sleeve are burred, corroded, or varnish accumulation is present, replace (WP 0289).
  - If regulating piston and sleeve check okay, proceed to step 6.
- Step 6. Disassemble fuel injection pump and check governor linkage for binding, foreign matter, and burrs; check metering valve for sticking condition (WP 0289; notify General Support Maintenance).
- If linkage is binding or burred, replace (WP 0289); if foreign matter is present, remove; if metering valve is sticking, replace (WP 0289).
  - If linkage and metering valve check okay and no foreign matter present, proceed to step 7.
- Step 7. Check governor linkage for proper adjustment (WP 0289; notify General Support Maintenance).
- Adjust governor linkage (WP 0289).
  - If governor linkage adjustment is okay, proceed to step 8.
- Step 8. Check governor linkage hook for proper adjustment (WP 0289; notify General Support Maintenance).
- If governor hook is not properly adjusted, adjust (WP 0289).
  - If governor hook is properly adjusted, proceed to step 9.
- Step 9. Disassemble fuel injection pump and check governor parts and linkage for wear, sticking condition, or binding (WP 0289; notify General Support Maintenance).
- If governor parts and linkage are worn, sticking, or binding, replace (WP 0289).
  - If governor parts and linkage are okay, proceed to step 10.
- Step 10. Check fuel injection pump maximum fuel setting on test set-up (WP 0289; notify General Support Maintenance).
- If fuel injection pump maximum fuel setting is not correct, adjust (WP 0289).
  - If fuel injection pump maximum fuel setting is okay, proceed to step 11.

---

<b>MALFUNCTION</b>
<b>TEST OR INSPECTION</b>
<b>CORRECTIVE ACTION</b>

---

**3. ENGINE HARD TO START (CONTINUED).**

- Step 11. Remove delivery valve and inspect for dirt or improper installation (WP 0289; notify General Support Maintenance).
- If delivery valve is dirty, clean or replace it; if improperly installed, install correctly (WP 0289).
  - If delivery valve is clean and properly installed, proceed to step 12.
- Step 12. Remove cam, shoes, and rollers and inspect for wear (WP 0289; notify General Support Maintenance).
- If cam, shoes, or rollers are worn, replace (WP 0289).
  - If cam, shoes, and rollers are okay, proceed to step 13.
- Step 13. Remove plungers and inspect for burrs, corrosion, or varnishes (WP 0289; notify General Support Maintenance).
- If plungers are burred, corroded, or varnish accumulation is present, replace (WP 0289).
  - If plungers are okay, proceed to step 14.
- Step 14. Check rotor and hydraulic head assembly (in plunger area) for wear (WP 0289; notify General Support Maintenance).
- If rotor and hydraulic head are worn in plunger area, replace (WP 0289).
  - If rotor and hydraulic head are okay, proceed to step 15.
- Step 15. Check adjustment of torque screw (WP 0289; notify General Support Maintenance).
- If torque screw out of adjustment, adjust (WP 0289).
  - If torque screw adjustment is okay, proceed to step 16.
- Step 16. Disassemble automatic advance components and inspect (WP 0289; notify General Support Maintenance).
- If automatic advance components are worn or damaged, replace and adjust (WP 0289).
  - If automatic advance components are okay, proceed to step 17.
- Step 17. Check delivery valve screw for tightness (WP 0289; notify General Support Maintenance).
- If delivery valve screw is loose, tighten (WP 0289).
  - If delivery valve screw is tight, remove it. Then, remove delivery valve and inspect seat for erosion (WP 0289).
    - If seat is eroded, replace delivery valve (WP 0289).
    - If seat is okay, reinstall, tighten delivery valve screw (WP 0289), and proceed to step 18.
- Step 18. Check rotor for scores (WP 0289; notify General Support Maintenance).  
Replace rotor (WP 0289).

---

**MALFUNCTION**  
**TEST OR INSPECTION**  
**CORRECTIVE ACTION**

---

**4. ENGINE STARTS AND STOPS.**

- Step 1. Check fuel injection pump timing (WP 0208).
- If fuel injection pump timing is not correct, adjust timing (WP 0208).
  - If fuel injection pump timing is okay, proceed to step 2.
- Step 2. Disconnect fuel lines from fuel injection pump at fuel injectors (WP 0229) one at a time, crank engine, and ensure fuel is pumped out of disconnected line.
- If fuel is not pumped out of any one disconnected fuel line when engine is cranked, replace associated connector screw; (WP 0289; notify General Support Maintenance). If fuel is not pumped out of any and all lines when disconnected, replace/clean inlet strainer (WP 0289; notify General Support Maintenance).
  - If fuel is cranked out of all lines when disconnected, proceed to step 3.
- Step 3. Remove governor control cover (notify General Support Maintenance) and check solenoid frame and arm assembly for cracks and swelling in encapsulated material and looseness of screw terminals. Check continuity using an ohmmeter (notify General Support Maintenance).
- If cracks, swelling, or loose screw terminals are observed, replace solenoid frame and arm assembly (WP 0289); if continuity is not obtained, replace solenoid frame and arm assembly (WP 0289).
  - If solenoid frame and arm assembly checks okay, proceed to step 4.
- Step 4. Disassemble fuel injection pump and check governor linkage for binding, foreign matter, and burrs; check metering valve for sticking condition (WP 0289; notify General Support Maintenance).
- If linkage is binding or burred, replace (WP 0289; if foreign matter is present, remove; if metering valve is sticking, replace (WP 0289).
  - If linkage and metering valve check okay and no foreign matter is present, proceed to step 5.
- Step 5. Disassemble fuel injection pump and check transfer pump parts for wear or damage (WP 0289; notify General Support Maintenance).
- If transfer pump parts are worn or damaged, replace (WP 0289).
  - If transfer pump parts check okay, proceed to step 6.
- Step 6. Disassemble fuel injection pump and check cam roller shoes for burrs; also check for freedom of rotation, chipping, and abrasive wear patterns (WP 0289; notify General Support Maintenance).
- Replace cam roller shoes if burred, sticking, chipped, or abrasive wear pattern observed (WP 0289).
  - If cam roller shoes check okay, proceed to step 7.
- Step 7. Remove plungers and inspect for burrs, corrosion, or varnishes (WP 0289; notify General Support Maintenance).
- If plungers are burred, corroded, or varnish accumulation is present, replace (WP 0289).



---

**MALFUNCTION**  
**TEST OR INSPECTION**  
**CORRECTIVE ACTION**

---

**5. ERRATIC ENGINE OPERATION (SURGE, MISFIRING, POOR GOVERNOR REGULATION).**

- Step 1. Check fuel injection pump timing (WP 0208).
- If fuel injection pump timing is not correct, adjust timing as described in WP 0208.
  - If fuel injection pump timing is okay, proceed to step 2.
- Step 2. Remove inlet strainer and check for clogged condition (WP 0289; notify General Support Maintenance).
- If inlet strainer is clogged, either clean or replace strainer (WP 0289).
  - If inlet strainer is not clogged, proceed to step 3.
- Step 3. Disconnect and remove fuel injector return lines (WP 0289). Check return lines for clogged condition.
- If fuel injector return lines are clogged, clean as described in WP 0229. After cleaning return lines, recheck to ensure all foreign matter has been removed, then reinstall (WP 0229).
  - If fuel injector return lines are not clogged, proceed to step 4.
- Step 4. Disassemble fuel injection pump and check automatic advance components (WP 0289; notify General Support Maintenance).
- If automatic advance components are worn or damaged, replace and adjust (WP 0289).
  - If automatic advance components are okay, proceed to step 5.
- Step 5. Disassemble fuel injection pump and check governor linkage for binding, foreign matter, and burrs; check metering valve for sticking condition (WP 0289; notify General Support Maintenance).
- If linkage is binding or burred, replace (WP 0289); if foreign matter is present, remove; if metering valve is sticking, replace (WP 0289).
  - If linkage and metering valve check okay and no foreign matter is present, proceed to step 6.
- Step 6. Check that metering valve spring shim is installed (WP 0289; notify General Support Maintenance).
- If metering valve spring shim is not installed, install (WP 0289).
  - If metering valve spring shim is installed, proceed to step 7.
- Step 7. Disassemble fuel injection pump and check governor parts and linkage for wear, sticking condition, or binding (WP 0289; notify General Support Maintenance).
- If governor parts and linkage are worn, sticking, or binding, replace (WP 0289).
  - If governor parts and linkage are okay, proceed to step 8.
- Step 8. Remove governor spring and inspect (WP 0289; notify General Support Maintenance).
- If governor spring is broken or permanently set, replace (WP 0289).
  - If governor spring checks okay, proceed to step 9.
- Step 9. Check governor linkage hook for correct adjustment (WP 0289; notify General Support Maintenance).
- If governor linkage hook is not adjusted properly, adjust as described in WP 0289.
  - If governor linkage hook is adjusted properly, proceed to step 10.

---

**MALFUNCTION**  
**TEST OR INSPECTION**  
**CORRECTIVE ACTION**

---

**5. ERRATIC ENGINE OPERATION (SURGE, MISFIRING, POOR GOVERNOR REGULATION) (CONTINUED).**

- Step 10. Remove and inspect idle spring (WP 0289; notify General Support Maintenance).
- If idle spring is broken or permanently set, replace (WP 0289).
  - If idle spring is okay, proceed to step 11.
- Step 11. Remove governor thrust sleeve and check for burrs and dirt (WP 0289; notify General Support Maintenance).
- Remove burrs using crocus cloth; clean governor thrust sleeve as described in (WP 0289).
  - If governor thrust sleeve checks okay, proceed to step 12.
- Step 12. Check transfer pump parts for wear or damage (WP 0289; notify General Support Maintenance).
- If transfer pump parts are worn or damaged, replace (WP 0289).
  - If transfer pump parts check okay, proceed to step 13.
- Step 13. Remove fuel injection pump regulating piston and sleeve and inspect for burrs, corrosion, and varnish accumulation (WP 0289; notify General Support Maintenance).
- If piston and sleeve are burred, corroded, or varnish accumulation is present, replace (WP 0289).
  - If piston and sleeve check okay, proceed to step 14.
- Step 14. Check delivery valve screw for tightness (WP 0289; notify General Support Maintenance).
- If delivery valve screw is loose, tighten (WP 0289).
  - If delivery valve screw is tight, remove it. Then, remove delivery valve and inspect seat for erosion (WP 0289).
    - If seat is eroded, replace delivery valve (WP 0289).
    - If seat is okay, reinstall and tighten delivery valve screw (WP 0289) and proceed to step 15.
- Step 15. Ensure valve for cleanliness or improper installation (WP 0289; notify General Support Maintenance).
- If delivery valve is dirty, clean or replace it (WP 0289); if improperly installed, install correctly (WP 0289).
  - If delivery valve is clean and properly installed, proceed to step 16.
- Step 16. Disassemble fuel injection pump and check cam roller shoes for burrs; also check for freedom of rotation, chipping, and abrasive wear patterns (WP 0289; notify General Support Maintenance).
- Replace cam roller shoes if burred, sticking, chipped, or abrasive wear pattern observed (WP 0289).
  - If cam roller shoes check okay, proceed to step 17.

---

**MALFUNCTION**  
**TEST OR INSPECTION**  
**CORRECTIVE ACTION**

---

**5. ERRATIC ENGINE OPERATION (SURGE, MISFIRING, POOR GOVERNOR REGULATION) (CONTINUED).**

- Step 17. Ensure hydraulic head screws are tight and not missing (WP 0289; notify General Support Maintenance).
- If hydraulic head screws are not tight or are missing, tighten and/or install (WP 0289).
  - If hydraulic head screws are tight and not missing, proceed to step 18.
- Step 18. Remove plungers and inspect for burrs, corrosion, or varnishes (WP 0289; notify General Support Maintenance).
- If plungers are burred, corroded, or varnish accumulation is present, replace (WP 0289).
  - If plungers are okay, proceed to step 19.
- Step 19. Check drive shaft tang dimension (should not be less than 0.305 in.) (WP 0289; notify General Support Maintenance).
- If drive shaft tang measures less than 0.305 in., replace drive shaft (WP 0289).
  - If drive shaft tang measures more than 0.305 in., replace head and rotor assembly (WP 0289).

**6. ENGINE IDLES IMPERFECTLY.**

- Step 1. Check fuel injection pump timing (WP 0208).
- If fuel injection pump timing is not correct, adjust timing as described in paragraph (WP 0208).
  - If fuel injection pump timing is okay, proceed to step 2.
- Step 2. Disassemble fuel injection pump and check transfer pump parts for wear or damage (WP 0289; notify General Support Maintenance).
- If transfer pump parts are worn or damaged, replace (WP 0289).
  - If transfer pump parts check okay, proceed to step 3.
- Step 3. Disassemble fuel injection pump and check governor parts and linkage for wear, sticking condition, or binding (WP 0289; notify General Support Maintenance).
- If governor parts and linkage are worn, sticking, or binding, replace (WP 0289).
  - If governor parts and linkage are okay, proceed to step 4.
- Step 4. Disassemble fuel injection pump and check governor linkage and metering valve for binding, foreign matter and burrs; check metering valve for sticking condition (WP 0289; notify General Support Maintenance).
- If linkage is binding or burred, replace (WP 0289); if foreign matter is present, remove; if metering valve is sticking, replace (WP 0289).
  - If linkage and metering valve check okay, proceed to step 5.

---

**MALFUNCTION**  
**TEST OR INSPECTION**  
**CORRECTIVE ACTION**

---

**6. ENGINE IDLES IMPERFECTLY (CONTINUED).**

- Step 5. Check that metering valve spring shim is installed (WP 0289; notify General Support Maintenance).
- If metering valve spring shim is not installed, install (WP 0289).
  - If metering valve spring shim is installed, proceed to step 6.
- Step 6. Remove and inspect idle spring (WP 0289; notify General Support Maintenance).
- If idle spring is broken or permanently set, replace (WP 0289).
  - If idle spring is okay, proceed to step 7.
- Step 7. Check governor linkage hook for proper adjustment (WP 0289; notify General Support Maintenance).
- If governor hook is not properly adjusted, adjust (WP 0289).
  - If governor hook is properly adjusted, proceed to step 8.
- Step 8. Disassemble automatic advance components and inspect (WP 0289; notify General Maintenance Support Maintenance).
- If automatic advance components are worn or damaged, replace and adjust (WP 0289).
  - If automatic advance components are okay, proceed to step 9.
- Step 9. Remove fuel injection pump regulating piston and sleeve and inspect for burrs, corrosion, and varnish accumulation (WP 0289; notify General Support Maintenance).
- If piston and sleeve are burred, corroded, or varnish accumulation is present, replace (WP 0289).
  - If piston and sleeve check okay, proceed to step 10.
- Step 10. Remove governor spring and inspect (WP 0289; notify General Support Maintenance).
- If governor spring is broken or permanently set, replace (WP 0289).
  - If governor spring checks okay, proceed to step 11.
- Step 11. Inspect governor linkage for breaks or cracks (WP 0289; notify General Support Maintenance).
- If governor linkage is broken or cracked, replace and adjust WP 0289.
  - If governor linkage checks okay, proceed to step 12.
- Step 12. Check that hydraulic head screws are tight or are not missing (WP 0289; notify General Support Maintenance).
- If hydraulic head screws are not tight or are missing, tighten and/or install (WP 0289).
  - If hydraulic head screws are tight and not missing, proceed to step 13.
- Step 13. Check rotor and hydraulic head assembly (in plunger area) for wear (WP 0289; notify General Support Maintenance).
- If rotor and hydraulic head are worn in plunger area, replace (WP 0289).
  - If rotor and head are okay, proceed to step 14.

---

**MALFUNCTION**  
**TEST OR INSPECTION**  
**CORRECTIVE ACTION**

---

**6. ENGINE IDLES IMPERFECTLY (CONTINUED).**

- Step 14. Remove delivery valve and inspect for dirt or improper installation (WP 0289; notify General Support Maintenance).
- If delivery valve is dirty, clean or replace it; if improperly installed, install correctly (WP 0289).
  - If delivery valve is clean and properly installed, proceed to step 15.
- Step 15. Remove plungers and inspect for burrs, corrosion or varnish accumulation (WP 0289; notify General Support Maintenance).
- Replace plungers if burred, corroded, or varnish accumulation is present (WP 0289).

**7. ENGINE DOES NOT DEVELOP FULL POWER OR SPEED.**

- Step 1. Check throttle arm installation and adjustment (WP 0074).
- If throttle arm installation is not correct or if adjustment is not correct, correct installation and adjust as described in paragraph (WP 0074).
  - If throttle arm installation is correct and if adjustment is correct, proceed to step 2.
- Step 2. Check governor linkage for proper adjustment (WP 0289; notify General Support Maintenance).
- Adjust governor linkage (WP 0289).
  - If governor linkage adjustment is okay, proceed to step 3.
- Step 3. Check governor no-load governed speed for proper adjustment (WP 0208).
- If governor no-load governed speed is not adjusted properly, adjust as described in WP 0208.
  - If governor no-load governed speed is adjusted properly, proceed to step 4.
- Step 4. Remove inlet strainer and check for clogged condition (WP 0289; notify General Support Maintenance).
- If inlet strainer is clogged, either clean or replace strainer (WP 0289).
  - If inlet strainer is not clogged, proceed to step 5.
- Step 5. Check fuel injection pump timing (WP 0208).
- If fuel injection pump timing is not correct, adjust timing as described in (WP 0208).
  - If fuel injection pump timing is okay, proceed to step 6.
- Step 6. Disconnect and remove fuel injector return lines (WP 0229).
- If fuel injector return lines are clogged, clean as described in WP 0229. After cleaning return lines, recheck to ensure that all foreign matter has been removed, then reinstall (WP 0229).
  - If fuel injector return lines are not clogged, proceed to step 7.

---

**MALFUNCTION**  
**TEST OR INSPECTION**  
**CORRECTIVE ACTION**

---

**7. ENGINE DOES NOT DEVELOP FULL POWER OR SPEED (CONTINUED).**

- Step 7. Disconnect fuel lines from fuel injection pump at fuel injectors (WP 0229) one at a time, crank engine and check that fuel is pumped out of disconnected fuel line.
- If fuel is not pumped out of disconnected fuel line when engine is cranked, replace associated connector screw (WP 0289; notify General Support Maintenance).
  - If fuel is pumped out of disconnected fuel line, proceed to step 8.
- Step 8. Disassemble fuel injection pump and check governor parts and linkage for wear, sticking condition, or binding (WP 0289; notify General Support Maintenance).
- If governor parts and linkage worn, sticking, or binding replace (WP 0289).
  - If governor parts and linkage are okay, proceed to step 9.
- Step 9. Disassemble fuel injection pump and check governor linkage and metering valve for binding, foreign matter and burrs; check metering valve for sticking condition (WP 0289; notify General Support Maintenance).
- If linkage is binding or burred, replace (WP 0289; if foreign matter is present, remove; if metering valve is sticking, replace (WP 0289).
  - If linkage and metering valve check okay, proceed to step 10.
- Step 10. Check governor linkage hook for proper adjustment (WP 0289; notify General Support Maintenance).
- If governor hook is not properly adjusted, adjust (WP 0289).
  - If governor hook is properly adjusted, proceed to step 11.
- Step 11. Disassemble automatic advance components and inspect (WP 0289; notify General Support Maintenance).
- If automatic advance components are worn or damaged, replace and adjust (WP 0289).
  - If automatic advance components are okay, proceed to step 12.
- Step 12. Disassemble fuel injection pump and check transfer pump parts for wear or damage (WP 0289; notify General Support Maintenance).
- If transfer pump parts are worn or damaged, replace (WP 0289).
  - If transfer pump parts check okay, proceed to step 13.
- Step 13. Check fuel injection pump maximum fuel setting on test set-up (WP 0289; notify General Support Maintenance).
- If fuel injection pump maximum fuel setting is not correct, adjust (WP 0289).
  - If fuel injection pump maximum fuel setting is okay, proceed to step 14.
- Step 14. Remove delivery valve and inspect for dirt or improper installation (WP 0289; notify General Support Maintenance).
- If delivery valve is dirty, clean or replace it; if improperly installed, install correctly (WP 0289).
  - If delivery valve is clean and properly installed, proceed to step 15.

---

**MALFUNCTION**  
**TEST OR INSPECTION**  
**CORRECTIVE ACTION**

---

**7. ENGINE DOES NOT DEVELOP FULL POWER OR SPEED (CONTINUED).**

- Step 15. Remove cam, shoes, and rollers and inspect for wear (WP 0289; notify General Support Maintenance).
- If cam, shoes, or rollers are worn, replace (WP 0289).
  - If cam, shoes, and rollers are okay, proceed to step 16.
- Step 16. Remove plungers and inspect for burrs, corrosion or varnishes (WP 0289; notify General Support Maintenance).
- If plungers are burred, corroded, or varnish accumulation is present, replace (WP 0289).
  - If plungers are okay, proceed to step 17.
- Step 17. Check rotor and hydraulic head assembly (in plunger area) for wear (WP 0289; notify General Support Maintenance).
- If rotor and hydraulic head are worn in plunger area, replace (WP 0289).
  - If rotor and hydraulic head are okay, proceed to step 18.
- Step 18. Check drive shaft tang dimension (should be not less than 0.305 inch) (7.75 mm) (WP 0289; notify General Support Maintenance).
- If drive shaft tang measures less than 0.305 inch, replace drive shaft (WP 0289).
  - If drive shaft tang measures more than 0.305 inch, proceed to step 19.
- Step 19. Check that hydraulic head screws are tight or are not missing (WP 0289; notify General Support Maintenance).
- If hydraulic head screws are not tight or are missing, tighten and/or install (WP 0289).
  - If hydraulic head screws are tight and not missing, proceed to step 20.
- Step 20. Check rotor for scores (WP 0289; notify General Support Maintenance).
- If rotor is scored, replace it (WP 0289).
  - If rotor is okay, proceed to step 21.
- Step 21. Check delivery valve screw for tightness (WP 0289; notify General Support Maintenance).
- If delivery valve screw is loose, tighten (WP 0289).
  - If delivery valve screw is tight, remove it. Then, remove delivery valve and inspect seat for erosion (WP 0289).
    - If seat is eroded, replace delivery valve (WP 0289).
    - If seat is okay, reinstall, tighten delivery valve screw (WP 0289) and proceed to step 22.
- Step 22. Check adjustment of torque screw (WP 0289; notify General Support Maintenance).
- If torque screw out of adjustment, adjust (WP 0289).
  - If torque screw adjustment is okay, proceed to step 23.

---

**MALFUNCTION**  
**TEST OR INSPECTION**  
**CORRECTIVE ACTION**

---

**7. ENGINE DOES NOT DEVELOP FULL POWER OR SPEED (CONTINUED).**

- Step 23. Check if hydraulic vent head wires are missing (WP 0289; notify General Support Maintenance).  
Install vent head wires (WP 0289).

**8. ENGINE SMOKES BLACK.**

- Step 1. Check fuel injection pump timing (WP 0208).
- If fuel injection pump timing is not correct, adjust timing as described in paragraph (WP 0208).
  - If fuel injection pump timing is okay, proceed to step 2.
- Step 2. Disassemble automatic advance components and inspect (WP 0289; notify General Support Maintenance).
- If automatic advance components are worn or damaged, replace and adjust (WP 0289).
  - If automatic advance components are okay, proceed to step 3.
- Step 3. Remove cam, shoes, and rollers and inspect for wear (WP 0289; notify General Support Maintenance).
- If cam, shoes, or rollers are worn, replace (WP 0289).
  - If cam, shoes, and rollers are okay, adjust torque screw (WP 0289).

**9. ENGINE SMOKES BLUE OR WHITE.**

- Step 1. Check fuel injection pump timing (WP 0208).
- If fuel injection pump timing is not correct, adjust timing as described in WP 0208.
  - If fuel injection pump timing is okay, proceed to step 2.
- Step 2. Disassemble automatic advance components and inspect (WP 0289; notify General Support Maintenance).
- If automatic advance components are worn or damaged, replace and adjust (WP 0289).
  - If automatic advance components are okay, proceed to step 3.
- Step 3. Check rotor for scores (WP 0289; notify General Support Maintenance).  
Replace rotor (WP 0289).



---

**MALFUNCTION**  
**TEST OR INSPECTION**  
**CORRECTIVE ACTION**

---

**10. FUEL NOT REACHING FUEL INJECTION PUMP.**

- Step 1. Disassemble fuel injection pump and check for cause of seizure of rotor assembly (WP 0289; notify General Support Maintenance).
- Replace hydraulic head and rotor assembly (WP 0289).
  - If hydraulic head and rotor assembly are okay, proceed to step 2.
- Step 2. Remove inlet strainer and check for clogged condition (WP 0289; notify General Support Maintenance).
- If inlet strainer is clogged, either clean or replace strainer (WP 0289).
  - If strainer is not clogged, proceed to step 3.
- Step 3. Disassemble transfer pump and check that transfer pump liner locating pin is in correct hole (WP 0289; notify General Support Maintenance).
- If locating pin is in wrong hole, remove and install in correct hole (WP 0289).
  - If locating pin is in correct hole, proceed to step 4.
- Step 4. Disassemble fuel injection pump and check transfer pump parts for wear or damage (WP 0289; notify General Support Maintenance).
- If transfer pump parts are worn or damaged, replace (WP 0289).
  - If transfer pump parts check okay, replace end plate regulating piston and sleeve (WP 0289).

**11. FUEL DELIVERED FROM TRANSFER PUMP BUT NOT TO FUEL INJECTORS.**

- Step 1. Remove governor control cover (WP 0289; notify General Support Maintenance) and check solenoid frame and arm assembly for cracks and swelling in encapsulated material and looseness of screw terminals. Check continuity using an ohmmeter (WP 0289; notify General Support Maintenance).
- If cracks, swelling or loose screw terminals are observed, replace solenoid frame and arm assembly (WP 0289); if continuity not obtained, replace solenoid frame and arm assembly (WP 0289).
  - If solenoid frame and arm assembly checks okay, proceed to step 2.
- Step 2. Disconnect fuel lines from fuel injection pump at fuel injectors (WP 0229) one at a time, crank engine and check that fuel is pumped out of disconnected fuel line.
- If fuel is not pumped out of disconnected fuel line when engine is cranked, replace associated connector screw (WP 0289; notify General Support Maintenance).
  - If fuel is pumped out of disconnected fuel line, proceed to step 3.
- Step 3. Disassemble fuel injection pump and check governor linkage for binding, foreign matter, and burrs; check metering valve for sticking condition (WP 0289; notify General Support Maintenance).
- If linkage is binding or burred, replace (WP 0289); if foreign matter is present, remove; if metering valve is sticking, replace (WP 0289).
  - If linkage and metering valve check okay and no foreign matter present, proceed to step 4.

---

**MALFUNCTION**  
**TEST OR INSPECTION**  
**CORRECTIVE ACTION**

---

**11. FUEL DELIVERED FROM TRANSFER PUMP BUT NOT TO FUEL INJECTORS (CONTINUED).**

- Step 4. Remove plungers and inspect for burrs, corrosion or varnishes (WP 0289; notify General Support Maintenance).
- If plungers are burred, corroded, or varnish accumulation is present, replace (WP 0289).
  - If plungers are okay, proceed to step 5.
- Step 5. Inspect governor linkage for breaks or cracks (WP 0289; notify General Support Maintenance).
- If governor linkage is broken or cracked, replace and adjust (WP 0289).
  - If governor linkage checks okay, proceed to step 6.
- Step 6. Disassemble fuel injection pump and check governor parts and linkage for wear, sticking condition, or binding (WP 0289; notify General Support Maintenance).
- If governor parts and linkage are worn, sticking, or binding replace (WP 0289).
  - If governor parts and linkage are okay, proceed to step 7.
- Step 7. Check adjustment of torque screw (WP 0289; notify General Support Maintenance).
- If torque screw out of adjustment, adjust (WP 0289).
  - If torque screw adjustment is okay, proceed to step 8.
- Step 8. Disassemble fuel injection pump and check that metering valve is assembled correctly to metering valve arm (WP 0289; notify General Support Maintenance).
- If metering valve is incorrectly assembled to metering valve arm, remove and install correctly (WP 0289).
  - If metering valve is correctly assembled to metering valve arm, proceed to step 9.
- Step 9. Disassemble fuel injection pump and check that cam is not installed backwards (WP 0289; notify General Support Maintenance).
- If cam is installed backwards, remove and install properly (WP 0289).
  - If cam is installed correctly, proceed to step 10.
- Step 10. Disassemble fuel injection pump and check cam roller shoes for burrs; also check for freedom of rotation, chipping, and abrasive wear patterns (WP 0289; notify General Support Maintenance).
- Replace cam roller shoes if burred, sticking, chipped, or abrasive wear pattern observed (WP 0289).
  - If cam roller shoes check okay, proceed to step 11.
- Step 11. Check that thrust plunger is installed (WP 0289; notify General Support Maintenance).
- If thrust plunger is missing, install (WP 0289).
  - If thrust plunger is installed, proceed to step 12.

---

**MALFUNCTION**  
**TEST OR INSPECTION**  
**CORRECTIVE ACTION**

---

**11. FUEL DELIVERED FROM TRANSFER PUMP BUT NOT TO FUEL INJECTORS (CONTINUED).**

- Step 12. Disassemble fuel injection pump and check transfer pump blades for wear or damage (WP 0289; notify General Support Maintenance).
- If transfer pump blades are worn or damaged, replace (WP 0289).
  - If transfer pump blades check okay, proceed to step 13.
- Step 13. Disassemble fuel injection pump and check for foreign matter in passage from transfer pump to metering valve (WP 0289; notify General Support Maintenance).
- Remove foreign matter (WP 0289).
  - If no foreign matter is present, proceed to step 14.
- Step 14. Check rotor for scores (WP 0289; notify General Support Maintenance).
- If rotor is scored, replace it (WP 0289).
  - If rotor is not scored, proceed to step 15.
- Step 15. Check that hydraulic head screws are tight or are not missing (WP 0289; notify General Support Maintenance).
- If hydraulic head screws are not tight or are missing, tighten and/or install (WP 0289).
  - If hydraulic head screws are tight and not missing, proceed to step 16.
- Step 16. Check if hydraulic head vent wires are missing (WP 0289; notify General Support Maintenance).
- If vent wires are missing, install (WP 0289).
  - If vent wires are installed, check and replace metering valve spring shim (WP 0289).

**12. FUEL REACHING FUEL INJECTORS BUT ENGINE WILL NOT START.**

- Step 1. Check fuel injection pump timing (WP 0208).
- If fuel injection pump timing is not correct, adjust timing as described in (WP 0208).
  - If fuel injection pump timing is okay, proceed to step 2.
- Step 2. Check throttle arm installation and adjustment (WP 0074).
- If throttle arm installation is not correct or if adjustment is not correct, correct installation and adjustment as described in WP 0074.
  - If throttle arm installation is correct and if adjustment is correct, proceed to step 3.
- Step 3. Check governor linkage for proper adjustment (WP 0289; notify General Support Maintenance).
- Adjust governor linkage (WP 0289).
  - If governor linkage adjustment is okay, proceed to step 4.

---

**MALFUNCTION**  
**TEST OR INSPECTION**  
**CORRECTIVE ACTION**

---

**12. FUEL REACHING FUEL INJECTORS BUT ENGINE WILL NOT START (CONTINUED).**

- Step 4. Check adjustment of torque screw (WP 0289; notify General Support Maintenance).
- If torque screw out of adjustment, adjust (WP 0289).
  - If torque screw adjustment is okay, proceed to step 5.
- Step 5. Disassemble automatic advance components and inspect (WP 0289; notify General Support Maintenance).
- If automatic advance components are worn or damaged, replace and adjust (WP 0289).
  - If automatic advance components are okay, proceed to step 6.
- Step 6. Check fuel injection pump maximum fuel setting on test set-up (WP 0289; notify General Support Maintenance).
- If fuel injection pump maximum fuel setting is not correct, adjust (WP 0289).
  - If fuel injection pump maximum fuel setting is okay, proceed to step 7.
- Step 7. Remove cam, shoes, and rollers and inspect for wear (WP 0289; notify General Support Maintenance).
- If cam, shoes, or rollers are worn, replace (WP 0289).
  - If cam, shoes, and rollers are okay, proceed to step 8.
- Step 8. Check rotor and hydraulic head assembly (in plunger area) for wear (WP 0289; notify General Support Maintenance).
- If rotor and hydraulic head are worn in plunger area, replace (WP 0289).
  - If rotor and hydraulic head are okay, proceed to step 9.
- Step 9. Check that hydraulic head screws are tight or are not missing (WP 0289; notify General Support Maintenance).
- If hydraulic head screws are not tight or are missing, tighten and/or install (WP 0289).
  - If hydraulic head screws are tight and not missing, proceed to step 10.
- Step 10. Check rotor for scores (WP 0289; notify General Support Maintenance).  
Replace rotor (WP 0289).

**END OF WORK PACKAGE**

# DIRECT SUPPORT TROUBLESHOOTING PROCEDURES

## FUEL SYSTEM TROUBLESHOOTING (MODEL 4-390)

---

### MALFUNCTION

### TEST OR INSPECTION

### CORRECTIVE ACTION

---

#### 1. ENGINE IDLE SPEED INCORRECT.

Perform fuel injection pump timing and idle speed adjustments (WP 0243).

- a. If idle speed screw on injection pump does not vary engine speed, replace fuel injection pump (WP 0234).
- b. If idle speed screw on injection pump changes engine speed, but will not adjust to correct value, check accelerator linkage (WP 0075). If accelerator linkage checks satisfactory, check fuel pressure (WP 0007) and fuel injectors (WP 0232). If above checks are satisfactory, replace fuel injection pump (WP 0234).

#### 2. ENGINE NO-LOAD GOVERNED SPEED INCORRECT.

Perform fuel injection pump timing and no-load governed speed adjustments (WP 0234).

- a. If high speed screw on injection pump does not vary engine speed, replace fuel injection pump (WP 0234).
- b. If high speed screw on injection pump varies engine speed, but will not reduce speed to correct value (no-load speed too high), replace fuel injection pump (WP 0234).
- c. If high speed screw on injection pump varies engine speed, but will not increase speed to correct value (no-load speed too low), check accelerator linkage (WP 0075), fuel pressure (WP 0007) and fuel injectors (WP 0232). If above checks are satisfactory, replace fuel injection pump (WP 0234).

#### 3. ENGINE HARD TO START.

Step 1. Check fuel injection pump timing (WP 0234).

- a. If fuel injection pump timing is not correct, adjust timing (WP 0234).
- b. If fuel injection pump timing is correct, proceed to step 2.

Step 2. Disconnect fuel lines from fuel injection pump at fuel injectors (WP 0230) one at a time, crank engine, and ensure fuel is pumped out of disconnected line.

If fuel is not pumped out of any one disconnected line when engine is cranked, replace fuel injector pump (WP 0234) (notify General Support Maintenance).

#### 4. ENGINE STARTS AND STOPS.

Step 1. Check fuel injection pump timing (WP 0234).

- a. If fuel injection pump timing is not correct, adjust timing (WP 0234).
- b. If fuel injection pump timing is correct, proceed to step 2.

Step 2. Disconnect fuel lines from fuel injection pump at fuel injectors (WP 0230) one at a time, crank engine and check that fuel is pumped out of disconnected line.

If fuel is not pumped out of any one disconnected fuel line when engine is cranked, replace fuel injector pump (WP 0234) (notify General Support Maintenance).

---

**MALFUNCTION**  
**TEST OR INSPECTION**  
**CORRECTIVE ACTION**

---

**5. ERRATIC ENGINE OPERATION (SURGE, MISFIRING, POOR GOVERNOR REGULATION).**

- Step 1. Check fuel injection pump timing (WP 0234).
- If fuel injection pump timing is not correct, adjust timing (WP 0234).
  - If fuel injection pump timing is correct, proceed to step 2.
- Step 2. Disconnect and remove fuel injector return lines (WP 0230). Check return lines for clogged condition.
- If fuel injector return lines are clogged, clean as described in WP 0230. After cleaning return lines, recheck to ensure all foreign matter has been removed, then reinstall (WP 0234).
  - If fuel injector return lines are not clogged, replace fuel injector pump (WP 0234).

**6. ENGINE IDLES IMPERFECTLY.**

- Check fuel injection pump timing (WP 0234).
- If fuel injection pump timing is not correct, adjust timing (WP 0234).
  - If fuel injection pump timing is correct, replace fuel injection pump (WP 0234).

**7. ENGINE DOES NOT DEVELOP FULL POWER OR SPEED.**

- Step 1. Check accelerator/throttle control installation and adjustment (WP 0075).
- If accelerator/throttle control installation is not correct or if adjustment is not correct, correct installation and adjust (WP 0075).
  - If accelerator/throttle control installation is correct and if adjustment is correct, proceed to step 2.
- Step 2. Check fuel injection pump timing (WP 0234).
- If fuel injection pump timing is not correct, adjust timing (WP 0234).
  - If fuel injection pump timing is correct, proceed to step 3.
- Step 3. Disconnect and remove fuel injector return lines (WP 0234). Check return lines for clogged condition.
- If fuel injector return lines are clogged, clean (WP 0234). After cleaning return lines, recheck to ensure that all foreign matter has been removed, then reinstall (WP 0230).
  - If fuel injector return lines are not clogged, proceed to step 4.
- Step 4. Disconnect fuel lines from fuel injection pump at fuel injectors (WP 0230) one at a time, crank engine and check that fuel is pumped out of disconnected fuel line.
- If fuel is not pumped out of disconnected fuel line when engine is cranked, replace fuel injector pump (WP 0234) (notify General Support Maintenance).

**8. ENGINE SMOKES BLACK.**

- Check fuel injection pump timing (WP 0234).
- If fuel injection pump timing is not correct, adjust timing (WP 0234).
  - If fuel injection pump timing is correct, replace fuel injection pump (WP 0234).

---

<b>MALFUNCTION</b>
<b>TEST OR INSPECTION</b>
<b>CORRECTIVE ACTION</b>

---

**9. ENGINE SMOKES BLUE OR WHITE.**

Check fuel injection pump timing (WP 0234).

- a. If fuel injection pump timing is not correct, adjust timing (WP 0234).
- b. If fuel injection pump timing is correct, replace fuel injection pump (WP 0234).

**10. FUEL REACHING FUEL INJECTORS BUT ENGINE WILL NOT START.**

Step 1. Check fuel injection pump timing (WP 0234).

- a. If fuel injection pump timing is not correct, adjust timing (WP 0234).
- b. If fuel injection pump timing is correct, proceed to step 2.

Step 2. Check accelerator/throttle control installation and adjustment (WP 0075).

- a. If accelerator/throttle control installation is not correct or if adjustment is not correct, reinstall and adjust (WP 0075).
- b. If accelerator/throttle control installation is correct and if adjustment is correct, replace fuel injection pump (WP 0234).

**END OF WORK PACKAGE**





# DIRECT SUPPORT TROUBLESHOOTING PROCEDURES

## ALTERNATOR TROUBLESHOOTING (MODEL 207)

---

### MALFUNCTION

### TEST OR INSPECTION

### CORRECTIVE ACTION

---

#### 1. IMPROPER OUTPUT VOLTAGE.

- Step 1. Connect test setup to alternator as shown. Slowly increase alternator speed and observe voltmeter reading.
- If voltmeter reading is uncontrolled with speed, and increases above 31 VDC, check alternator field winding and regulator (WP 0237).
  - If voltmeter indicates battery voltage (no increase in voltage), proceed to step 2.
  - If voltmeter reading increases (greater than battery voltage and less than 31 VDC), proceed to MALFUNCTION 2.

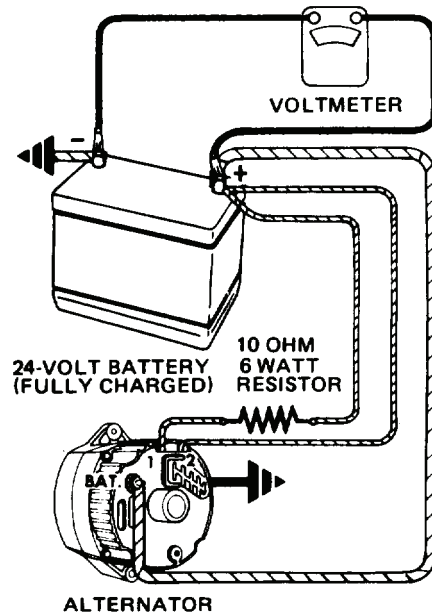

TA127129

---

MALFUNCTION
TEST OR INSPECTION
CORRECTIVE ACTION

---

**1. IMPROPER OUTPUT VOLTAGE (CONTINUED).****CAUTION**

Tab is within 3/4 in. (19 mm) of casting surface. Do not force screwdriver deeper than 1 in. (25 mm) into alternator end frame.

- Step 2. Insert screwdriver into test hole in end frame and ground as shown; then repeat step 1.
- If voltmeter indicates battery voltage (no increase in voltage), check rotor, stator, diode trio, rectifier bridge, and regulator mounting screws (WP 0237).
  - If voltmeter reading increases, replace regulator (WP 0237).

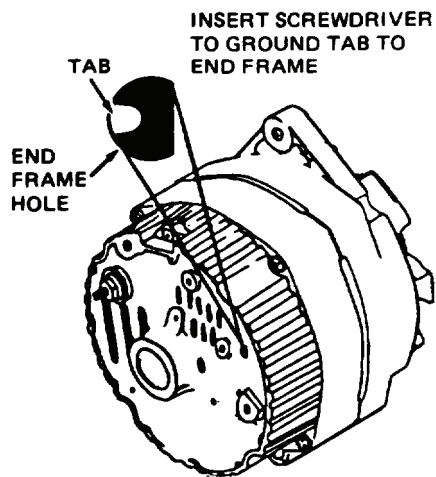

TA127130

---

MALFUNCTION	TEST OR INSPECTION	CORRECTIVE ACTION
-------------	--------------------	-------------------

---

## 2. IMPROPER OUTPUT CURRENT.

- Step 1. Connect test setup to alternator as shown. Operate alternator at moderate speed and adjust carbon pile for maximum indication on ammeter. Note ammeter indication.
- If ammeter indicates 27 to 47 amperes, and voltmeter indicates less than 31 VDC, alternator operation is normal.
  - If ammeter does not indicate 27 to 47 amperes, proceed to step 2.

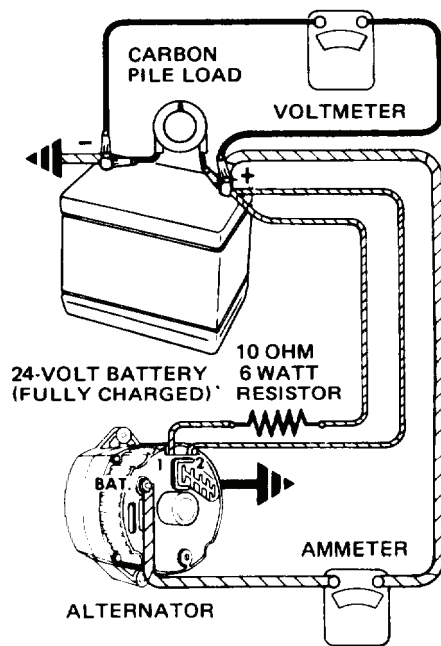

---

MALFUNCTION
TEST OR INSPECTION
CORRECTIVE ACTION

---

**2. IMPROPER OUTPUT CURRENT (CONTINUED).****CAUTION**

Tab is within 3/4 in. (19 mm) of casting surface. Do not force screwdriver deeper than 1 in. (25 mm) into alternator end frame.

- Step 2. Insert screwdriver into test hole in end frame and ground tab as shown; then repeat step 1.
- If ammeter indicates 27 to 47 amperes, check field winding and regulator (WP 0237).
  - If ammeter indicates 27 to 47 amperes, check alternator field winding, diode trio, rectifier bridge, and stator (WP 0237).

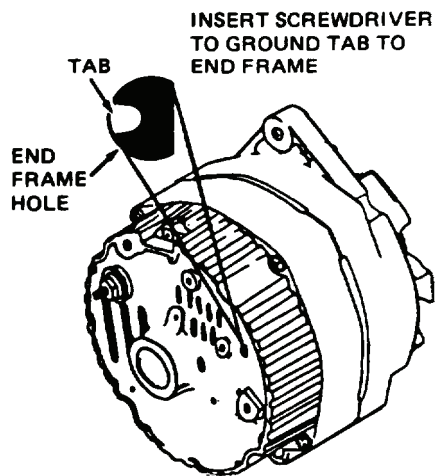

TA127130

**END OF WORK PACKAGE**

# DIRECT SUPPORT TROUBLESHOOTING PROCEDURES

## STARTER AND SOLENOID TROUBLESHOOTING (MODEL 207)

**MALFUNCTION**  
**TEST OR INSPECTION**  
**CORRECTIVE ACTION**

**1. STARTER TROUBLESHOOTING.**

**NOTE**

Compare results of starter no-load test (WP 0012, STARTER CRANKS TOO SLOWLY) with the following table, then refer to WP 0238.

<b>ARMATURE SPEED</b>	<b>CURRENT DRAW</b>	<b>PROBABLE CAUSE</b>	<b>INSPECTION DATA</b>
Zero	Zero	Open field circuit.	Check internal connections and field coils for open condition.
		Open armature coils.	Inspect commutator for badly burned bars after disassembly.
		Poor brush contact.	Check for broken brush springs, worn brushes, and high insulation between commutator bars.
Zero	High	Grounded terminals or fields.	Disconnect field coil ground connections and check for grounded condition.
		Frozen bearings.	Rotate armature by prying pinion with a screwdriver.
Low	Low	High internal resistance.	Check for poor connections, defective leads, and dirty commutator.
Low	High	Excessive friction.	Check for tight, dirty, or worn bearings, bent armature shaft or loose pole shoes allowing armature to drag.
		Shorted armature. Grounded field coils or armature.	Check armature in a growler after disassembly. Disconnect field coil ground connections and check for grounded condition.
High	High	Shorted field coils.	Replace field coils and repeat bench test.

---

MALFUNCTION	TEST OR INSPECTION	CORRECTIVE ACTION
-------------	--------------------	-------------------

---

## 2. STARTER FAILS TO CRANK.

- Step 1. Disconnect and tape field coil lead at solenoid M terminal. Connect solenoid terminals to test setup as shown. Close switch, adjust carbon pile for 9 VDC indication on voltmeter, and note ammeter reading.
- If ammeter indicates 6.5 to 7.0 amperes, proceed to step 2.
  - If ammeter does not indicate 6.5 to 7.0 amperes, replace solenoid switch (WP 0238).

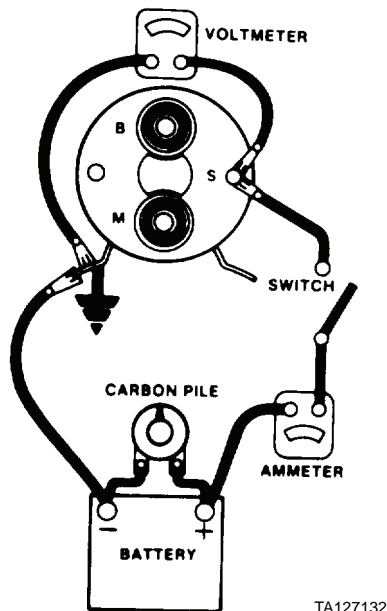

- Step 2. Reconnect solenoid terminals to pull-in winding test setup as shown.

### CAUTION

To prevent overheating solenoid, do not close switch for more than 15 seconds at a time.

Close switch and adjust carbon pile for 20 VDC indication on voltmeter. Note ammeter reading and open switch.

- If ammeter indicates 6.5 to 7.0 amperes, remove solenoid (WP 0238) and check for binding plunger or defective spring.
- If ammeter indicates more than 7.0 amperes, winding is shorted or grounded. Replace solenoid (WP 0238).
- If ammeter indicates less than 6.5 amperes, winding has excessive resistance. Clean solenoid terminals and repeat pull-in winding test. If ammeter still indicates less than 6.5 amperes, replace solenoid (WP 0238).

**END OF WORK PACKAGE**

---

## DIRECT SUPPORT TROUBLESHOOTING PROCEDURES

### WIRING HARNESS TROUBLESHOOTING (MODEL 207)

---

MALFUNCTION
TEST OR INSPECTION
CORRECTIVE ACTION

---

**1. MAJOR PORTION OF ELECTRICAL SYSTEM INOPERATIVE.**

#### NOTE

Refer to electrical system wiring schematic (WP 0306), front wiring harness illustration (WP 0240 ), and rear wiring harness illustration (WP 0242).

Check for improper connection or defective connectors between front and rear wiring harness, ignition switch and connector, and vehicle lights switch and connector.

If connections are correct, replace front wiring harness (WP 0240) or rear wiring harness (WP 0242).

**2. ONE ELECTRICAL CIRCUIT INOPERATIVE.**

- Step 1.     Disconnect harness lead(s) from affected component, and use an ohmmeter to check for open circuit caused by breaks in wiring or faulty connectors.
  - a.     If harness wire is broken, and wire is not accessible, replace wiring harness (WP 0240 or WP 0242).
  - b.     If harness wire is not broken, proceed to step 2.
- Step 2.     Use an ohmmeter to check for short circuit caused by damaged insulation, screw driven through wire, or wires from different circuits making contact.
  - a.     If harness wire is shorted or grounded, and not accessible for repair, replace wiring harness (WP 0240 or WP 0242).
  - b.     If harness wire is not shorted, test electrical component in affected circuit (refer to Organizational Maintenance).

**END OF WORK PACKAGE**





---

## DIRECT SUPPORT TROUBLESHOOTING PROCEDURES

### WIRING HARNESS TROUBLESHOOTING (MODEL 4-390)

---

MALFUNCTION
TEST OR INSPECTION
CORRECTIVE ACTION

---

#### NOTE

Refer to electrical system wiring schematic (appendix F), front wiring harness illustration (WP 0241), and rear wiring harness illustration (WP 0243).

#### 1. MAJOR PORTION OF ELECTRICAL SYSTEM INOPERATIVE.

Check for improper connection or defective connectors between front and rear wiring harnesses, ignition switch and connector, and vehicle lights switch and connector.

If connections are correct, replace front wiring harness (WP 0241) or rear wiring harness (WP 0243).

#### 2. ONE ELECTRICAL CIRCUIT INOPERATIVE.

Step 1. Disconnect harness lead(s) from affected component, and use an ohmmeter to check for open circuit caused by breaks in wiring or faulty connectors.

- a. If harness wire is broken, and wire is not accessible, replace wiring harness (WP 0241 and WP 0243).
- b. If harness wire is not broken, proceed to step 2.

Step 2. Use an ohmmeter to check for short circuit caused by damaged insulation, screw driven through wire, or wires from different circuits making contact.

- a. If harness wire is shorted or grounded, and not accessible for repair, replace wiring harness (WP 0241 and WP 0243).
- b. If harness wire is not shorted, test electrical component in affected circuit (refer to Organizational Maintenance).

**END OF WORK PACKAGE**



---

## DIRECT SUPPORT TROUBLESHOOTING PROCEDURES

### TRANSMISSION TROUBLESHOOTING

---

MALFUNCTION
TEST OR INSPECTION
CORRECTIVE ACTION
<p><b>1. HIGH TRANSMISSION OIL TEMPERATURE.</b></p> <p>Check transmission lube pressure at lube pressure port (WP 0248, steps 6 through 8).</p> <ol style="list-style-type: none"> <li>a. If lube pressure is low, replace charging pump assembly (WP 0251).</li> <li>b. If lube pressure is normal, replace transmission (WP 0211 and WP 0213 for original vehicle or WP 0212 and WP 0214 for replacement vehicle) (torque converter oil sealing rings worn and require replacement) and notify General Support Maintenance.</li> </ol> <p><b>2. LOSS OF DRIVE IN ALL RANGES.</b></p> <p>Step 1. Perform step 5 of WP 0019, MALFUNCTION 4. Replace control valve assembly (WP 0250); if replacement of control valve does not help, proceed to step 2.</p> <p>Step 2. Perform steps 1, 3, 4, and 5a through 5f of WP 0248.</p> <ol style="list-style-type: none"> <li>a. If pressure gage indication is abnormal, proceed to step 3.</li> <li>b. If pressure gage indication is normal, proceed to step 3.</li> </ol> <p>Step 3. Perform steps 6 through 8 of WP 0248. If lube pressure indication is abnormal, replace charging pump assembly (WP 0208) and repeat step 2 above. If pressure gage indication obtained in step 2 is still abnormal, replace transmission (WP 0211 and WP 0213 for original vehicle or WP 0212 and WP 0214 for replacement vehicle) (torque converter oil sealing rings worn and require replacement) and Notify General Support Maintenance.</p>

---

**MALFUNCTION**  
**TEST OR INSPECTION**  
**CORRECTIVE ACTION**

---

**3. LOSS OF POWER AND/OR LOSS OF DRIVE IN ANY ONE RANGE.**

Step 1. Perform steps 1, 3, 4, and 5a through 5f of WP 0248.

- a. If pressure gage indication is abnormal, proceed to step 2.
- b. If pressure gage indication is normal, proceed to step 3.

Step 2. Perform steps 6 through 8 of WP 0248.

If lube pressure indication is abnormal, replace charging pump assembly (WP 0208) and repeat step 1 above. If pressure gage indication obtained in step 1 is still abnormal, replace transmission (WP 0212 and WP 0214) (torque converter oil sealing rings worn and require replacement) and notify General Support Maintenance.

Step 3. Perform steps 1, 3, 4, and 5 of WP 0248.

- a. If pressure indications normal in F (forward) but abnormal in R (reverse), replace transmission (WP 0208) (reverse and second clutch group require repair) and notify General Support Maintenance.
- b. If pressure indications normal in R (reverse) but abnormal in F (forward), replace transmission (WP 0211 and WP 0213 for original vehicle or WP 0212 and WP 0214 for replacement vehicle) (forward clutch group requires repair) and notify General Support Maintenance.
- c. If pressure indication in any one position of speed selector varies more than 5 PSI (34 kPa) from other indications, replace transmission (WP 0211 and WP 0213 for original vehicle or WP 0212 and WP 0214 for replacement vehicle) (clutch group associated with speed selector position in which pressure indication varied more than 5 PSI (34 kPa) requires repair) and notify General Support Maintenance.

**END OF WORK PACKAGE**

---

# DIRECT SUPPORT TROUBLESHOOTING PROCEDURES

## AXLES AND DIFFERENTIAL CARRIER ASSEMBLIES TROUBLESHOOTING

---

MALFUNCTION
TEST OR INSPECTION
CORRECTIVE ACTION

---

**1. CONTINUOUS AXLE OR WHEEL NOISE.**



**WARNING**

Before raising wheel off ground, ensure shipping lock pin is installed. Failure to do so may cause vehicle to turn and slip off jack or jack stands causing serious injury or death. If you are injured by failing equipment, obtain medical aid immediately.

Check axle shafts for damage (WP 0160).

If axle shafts are not damaged, replace differential carrier assembly WP 0255 or WP 0256 and notify General Support Maintenance.

**2. LUBRICANT LEAKING FROM DIFFERENTIAL CARRIER ASSEMBLY.**

Step 1. Check if lubricant is leaking between axle housing and differential carrier assembly.

If lubricant is leaking between axle housing and differential carrier assembly, remove differential carrier assembly, clean mating surfaces, apply sealer, and reinstall (WP 0255 or WP 0256).

Step 2. Check if lubricant is leaking from differential carrier assembly housing (indicating cracked housing) or from area near yoke.

Step 3. Remove and replace differential carrier assembly (WP 0255 or WP 0256) and notify General Support Maintenance.

**END OF WORK PACKAGE**



---

# DIRECT SUPPORT TROUBLESHOOTING PROCEDURES

## HYDRAULIC PUMP TROUBLESHOOTING

---

### MALFUNCTION

### TEST OR INSPECTION

### CORRECTIVE ACTION

---

#### 1. VEHICLE WILL NOT TURN WHEN STEERING WHEEL IS TURNED.

- Step 1. Ensure steering bypass valve is closed (extreme clockwise position) and hydraulic reservoir is filled with oil (refer to LO 10-3930-638-12).
- a. Start engine and run at full throttle while operating lift and tilt control levers.
  - b. Ensure mast assembly operates normally when levers are actuated; then stop engine.
    1. If mast assembly does not operate normally, proceed to step 2.
    2. If mast assembly operates normally, proceed to MALFUNCTION 2 in this work package.
- Step 2. Check setting of hydraulic relief valve.
- a. If pressure indication is 2,500 to 2,550 PSI (17,237 to 17,582 kPa), proceed to MALFUNCTION 2 in this work package.
  - b. If pressure indication is not 2,500 to 2,500 PSI, adjust relief valve. If adjusting relief valve does not change pressure indication, replace relief valve. If adjusting relief valve changes pressure indication, but will not adjust to 2,500 to 2,500 PSI (17,237 to 17,582 kPa), repair hydraulic pump.

#### 2. HYDRAULIC OIL FOAMING.

- Step 1. Check for air leakage in suction hose, clamps, and fittings to hydraulic pump.
- a. If air is leaking into suction hose, tighten clamps or replace fittings or hose.
  - b. If air is not leaking into suction hose, proceed to MALFUNCTION 3 in this work package.
- Step 2. Replace alternator if testing indicates alternator if defective (WP 0094).

#### 3. EXCESSIVE HYDRAULIC PUMP NOISE.

- Step 1. Check for illuminated hydraulic filter indicator light.
- a. If hydraulic filter light is on, replace hydraulic oil filter. If hydraulic filter light remains on after changing oil filter, check for clogged hoses and fittings.
  - b. If hydraulic filter indicator light is not on, proceed to step 2.
- Step 2. Check for plugged hydraulic reservoir strainer.
- a. Clean strainer to remove obstructions.
  - b. If strainer is clean and hydraulic pump operation is still noisy, proceed to step 3.
- Step 3. Check for plugged suction hose and fittings.
- a. Replace obstructed suction hose and fittings.
  - b. If suction hose and fittings are not obstructed, repair hydraulic pump.

**END OF WORK PACKAGE**





---

## DIRECT SUPPORT TROUBLESHOOTING PROCEDURES

### STEERING COLUMN AND CYLINDER TROUBLESHOOTING

---

MALFUNCTION
TEST OR INSPECTION
CORRECTIVE ACTION
<p><b>1. EFFORT TO TURN IN ONE DIRECTION IS MORE THAN REQUIRED IN OTHER DIRECTION.</b></p> <p style="margin-left: 20px;">a. Disconnect horn switch to gain access to steering wheel retaining nut. Park vehicle on dry pavement and center steering wheel. Start engine and operate at a fast idle. Using a torque wrench on steering wheel retaining nut, measure and record effort required to turn steering wheel right. Then, center steering wheel and measure and record effort required to turn steering wheel left. Difference between two torque readings should be less than 2 lb-in.</p> <p style="margin-left: 20px;">b. If difference between torque readings for left turn and right turn is more than 2 lb-in., steering gear is damaged or has incorrect shims installed. Repair steering gear.</p> <p><b>2. STEERING WHEEL TURNS HARD IN BOTH DIRECTIONS.</b></p> <p style="margin-left: 20px;">Step 1. Park vehicle on dry pavement with engine off. Turn steering wheel in both directions and check for binding or unusual noises at steering column.</p> <p style="margin-left: 40px;">a. If binding or unusual noises are detected, repair steering column.</p> <p style="margin-left: 40px;">b. If steering wheel turns smoothly, without binding or unusual noises, proceed to step 2.</p> <p style="margin-left: 20px;">Step 2. Rotate steering wheel until vehicle is fully turned (articulated) left. With engine off, loosen two clamps and slide cylinder guard toward front of vehicle, and disconnect hose from elbow as shown.</p>

---

**MALFUNCTION**  
**TEST OR INSPECTION**  
**CORRECTIVE ACTION**

---

**2. STEERING WHEEL TURNS HARD IN BOTH DIRECTIONS (CONTINUED).****WARNING**

Keep hands and feet clear of steering cylinder assembly while checking for leakage. Failure to do so could cause bodily injury.

Start engine and hold steering wheel at the full right turn position. Check for hydraulic oil leakage from the open steering cylinder elbow, then stop engine.

- a. Hydraulic oil coming from open steering cylinder elbow indicates internal steering cylinder leakage. Repair steering cylinder (WP 0260).
- b. If hydraulic oil does not leak from open steering cylinder elbow, proceed to step 3.

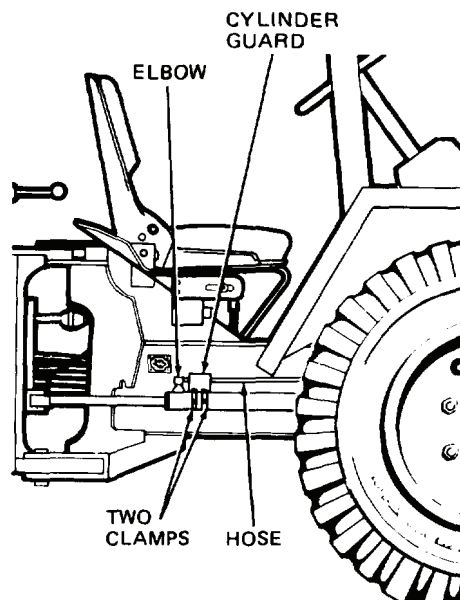

TA127156

---

MALFUNCTION	TEST OR INSPECTION	CORRECTIVE ACTION
-------------	--------------------	-------------------

---

## 2. STEERING WHEEL TURNS HARD IN BOTH DIRECTIONS (CONTINUED).

- Step 3. Rotate steering wheel until vehicle is fully turned (articulated) to the right. With engine off, loosen two clamps and slide cylinder guard toward front of vehicle, and disconnect hose from elbow as shown.



### WARNING

Keep hands and feet clear of steering cylinder assembly while checking for leakage. Failure to do so could cause bodily injury.

Start engine and hold steering wheel at the full right turn position. Check for hydraulic oil leakage from the open steering cylinder elbow, then stop engine.

- Hydraulic oil coming from open steering cylinder elbow indicates internal steering cylinder leakage. Repair steering cylinder (WP 0260).
- If hydraulic oil does not leak from open steering cylinder elbow, replace steering gear (WP 0258).

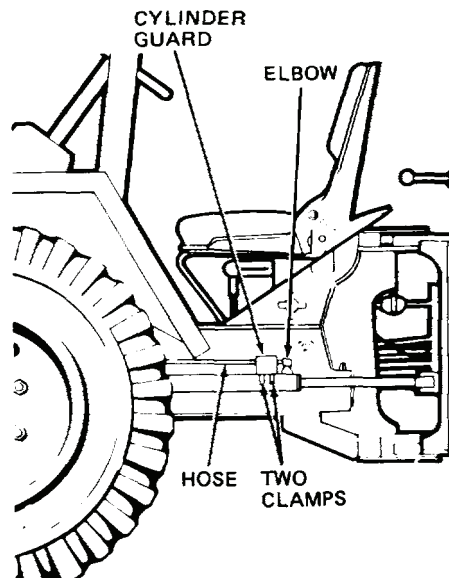

TA127157

END OF WORK PACKAGE



---

## DIRECT SUPPORT TROUBLESHOOTING PROCEDURES

### CHASSIS TROUBLESHOOTING

---

**MALFUNCTION****TEST OR INSPECTION****CORRECTIVE ACTION**

---

**1. EXCESSIVE NOISE AT CHASSIS PIVOT POINT WHEN TURNING.**

Lubricate two grease fittings at chassis pivot points (refer to LO 10-3930-638-12).

If lubrication does not reduce noise at pivot points, remove and check grease fittings for damage (WP 0261).

**2. EXCESSIVE PLAY AT CHASSIS PIVOT POINT WHEN TURNING.**

Carefully observe chassis pivot points while an assistant slowly drives vehicle over rough terrain.

If excessive play is observed at chassis pivot points, replace pivot bushing, bearing, or pin (WP 0261).

**END OF WORK PACKAGE**



---

## DIRECT SUPPORT TROUBLESHOOTING PROCEDURES

### HYDRAULIC LIFT SYSTEM TROUBLESHOOTING

---

**MALFUNCTION****TEST OR INSPECTION****CORRECTIVE ACTION**

---

**1. UNABLE TO LIFT A LOAD (ALL OTHER FUNCTIONS NORMAL).****NOTE**

After completion of each check, lower forks until resting on ground. Then, turn engine off.

Step 1. Start engine and operate at idle speed.

**NOTE**

Increase engine speed as necessary in the following steps to prevent engine stall.

- a. With no load on forks, place lift control lever in RAISE position until tube assembly shown is warm to touch (mast assembly will be at full height).

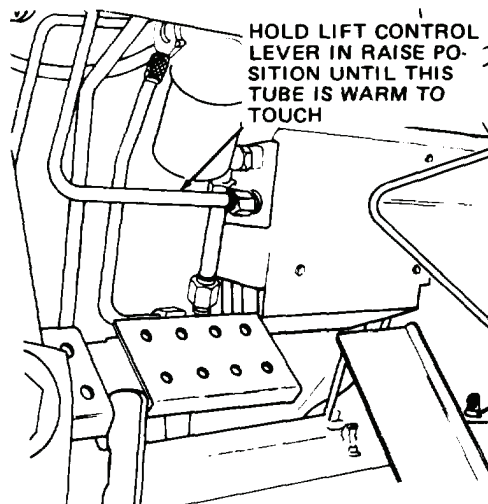

TA127040

---

**MALFUNCTION**  
**TEST OR INSPECTION**  
**CORRECTIVE ACTION**

---

**1. UNABLE TO LIFT A LOAD (ALL OTHER FUNCTIONS NORMAL) (CONTINUED).**



**WARNING**

Do not look directly down at fitting when performing the following steps; hydraulic oil is under pressure. Serious injury may result.

- b. Loosen bleed fitting at top of lift cylinder assembly.

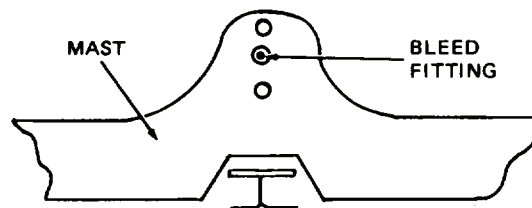

TA127051

**NOTE**

While an assistant places lift control lever in RAISE position, observe fitting at top of lift cylinder assembly for hydraulic oil leakage. (Slight weeping of oil is permissible.)

- c. If hydraulic oil leakage (other than slight weeping) is observed, remove lift cylinder assembly (WP 0266) and check piston assembly and wear rings (WP 0266); repair/replace as necessary.
  - d. If hydraulic oil leakage is not observed, tighten bleed fitting and proceed to step 2.
- Step 2. With engine at idle speed and lift control lever in RAISE position (mast assembly will be at full height), check for hydraulic oil leakage at gland assembly (located at bottom of lift cylinder assembly) and at ring assembly (located at bottom of lift cylinder body).

**NOTE**

Increase engine speed as necessary to prevent engine stall.

- a. If hydraulic oil leakage is observed, remove lift cylinder assembly (WP 0266), and repair or replace gland assembly or ring assembly (WP 0266).
- b. If hydraulic oil leakage is not observed, proceed to step 4.



---

**MALFUNCTION**  
**TEST OR INSPECTION**  
**CORRECTIVE ACTION**

---

**1. UNABLE TO LIFT A LOAD (ALL OTHER FUNCTIONS NORMAL) (CONTINUED).**

- Step 3. With engine at idle speed and lift control lever in RAISE position (mast assembly will be at full height), check for hydraulic oil leakage at gland assembly (located at bottom of lift cylinder assembly) and at ring assembly (located at bottom of lift cylinder body).
- If hydraulic oil leakage is observed, remove lift cylinder assembly (WP 0266), and repair or replace gland assembly or ring assembly (WP 0266).
  - If hydraulic oil leakage is not observed, proceed to step 4.
- Step 4. Start engine and operate at idle speed.

**NOTE**

Increase engine speed as necessary to prevent engine stall.

- Replace or repair control valve (WP 0262) if hydraulic oil leakage is observed.
  - If hydraulic oil leakage is not observed, proceed to step 5.
- Step 5. With engine off, operate control levers several times to relieve hydraulic pressure. Disconnect hose assembly connected between control valve and lift cylinder assembly at control valve as shown. Connect a 3,000 PSI (207 bar) pressure gage between elbow on control valve and hose assembly.

**NOTE**

Increase engine speed as necessary to prevent engine stall.

- Start engine and place lift control lever in RAISE position until mast assembly is at full height; continue to hold lever in RAISE position.
- Pressure gage should indicate 2,500 to 2,550 PSI (17,237 to 17,582 kPa) with engine at full throttle.

**DISCONNECT HOSE ASSEMBLY.  
CONNECT PRESSURE GAGE  
BETWEEN HOSE ASSEMBLY  
AND ELBOW**

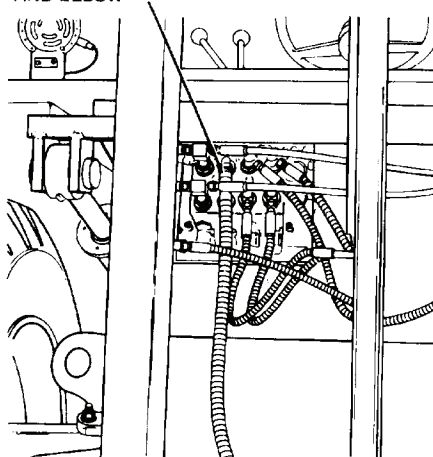

TA127170

---

MALFUNCTION	TEST OR INSPECTION	CORRECTIVE ACTION
-------------	--------------------	-------------------

---

**1. UNABLE TO LIFT A LOAD (ALL OTHER FUNCTIONS NORMAL) (CONTINUED).**

- c. If pressure gage indication is above or below 2,500 to 2,550 PSI (17,237 to 17,582 kPa), adjust pressure relief valve (WP 0172, step 23).
- d. If pressure gage indication is between 2,500 to 2,550 PSI (17,237 to 17,582 kPa), remove and repair lift cylinder assembly (WP 0266).

**2. LOAD DRIFTS DOWN.****NOTE**

After completion of each check, lower forks until resting on ground. Then turn engine off.

With engine off, operate control levers several times to relieve hydraulic pressure. Disconnect hose assembly connected between control valve and lift cylinder assembly at control valve (as shown).

**NOTE**

Increase engine speed as necessary to prevent engine stall.

- a. Connect a 3,000 PSI (207 bar) pressure gage between elbow on control valve and hose assembly.
- b. Start engine and place lift control lever in RAISE position until mast assembly is at full height; continue to hold lever in RAISE position until pressure gage indicates 2,500 to 2,550 PSI (17,237 to 17,582 kPa) with engine at full throttle. With lift control lever in NEUTRAL position, observe pressure gage and mast assembly.
  - 1. If mast assembly drifts down and pressure gage indication does not decrease, remove and repair lift cylinder assembly (WP 0266).
  - 2. If pressure gage indication decreases, replace or repair control valve (WP 0262).

**3. UNABLE TO SIDESHIFT LOAD (ALL OTHER FUNCTIONS NORMAL).****NOTE**

After completion of each check, turn engine off.

- Step 1. Check sideshift cylinder assembly for hydraulic oil leakage.
  - a. If hydraulic oil leakage is observed, remove and repair sideshift cylinder assembly (WP 0264).
  - b. If hydraulic oil leakage is not observed, proceed to step 2.
- Step 2. Check hose assemblies between sideshift cylinder assembly and control valve for hydraulic oil leakage.
  - a. If hydraulic oil leakage is observed at hose assemblies, replace leaking hose assembly (WP 0195, WP 0196, and WP 0197).
  - b. If hydraulic oil leakage is not observed at hose assemblies, proceed to step 3.
- Step 3. Check control valve for hydraulic oil leakage.
  - a. If hydraulic oil leakage is observed at control valve, remove and repair (WP 0262).
  - b. If hydraulic oil leakage is not observed at control valve, proceed to step 4.

---

**MALFUNCTION**  
**TEST OR INSPECTION**  
**CORRECTIVE ACTION**

---

**3. UNABLE TO SIDESHIFT LOAD (ALL OTHER FUNCTIONS NORMAL) (CONTINUED).**

- Step 4. Crack (loosen) fittings shown. Start engine and operate at idle speed. Place shift control lever in left position and check if hydraulic oil flows from fittings; place shift control lever in RIGHT position and check if hydraulic oil flows from fittings.
- If hydraulic oil does not flow from fittings, replace control valve (WP 0262).
  - If hydraulic oil flows from fittings, remove and repair sideshift cylinder assembly (WP 0264) (tighten fittings).

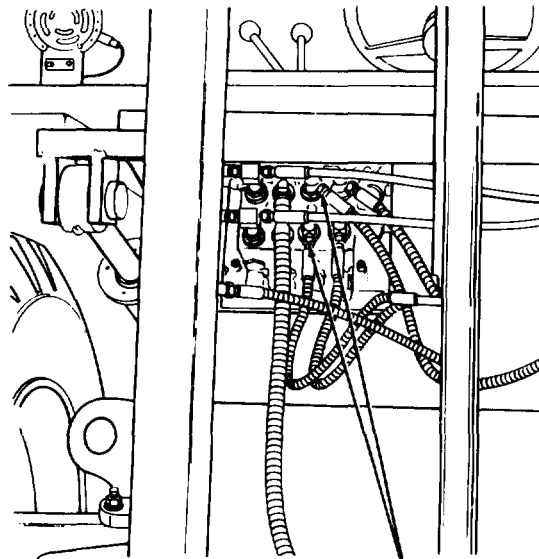

**LOOSEN THESE TWO HOSE  
FITTINGS (TIGHTEN AFTER  
COMPLETION OF CHECKS)**

TA127171

---

<b>MALFUNCTION</b>
<b>TEST OR INSPECTION</b>
<b>CORRECTIVE ACTION</b>

---

**4. SIDESHIFT CYLINDER ASSEMBLY OPERATION SLUGGISH.****NOTE**

After completion of each check, turn engine off.

- Step 1. Check pressure relief valve setting (WP 0172, steps 20 through 22).
- If pressure relief valve setting is not correct, adjust for proper setting (WP 0172, step 23).
  - If pressure relief valve setting is okay, proceed to step 2.
- Step 2. Start engine and operate at idle speed.
- Place shift control lever in LEFT position until forks are in extreme LEFT position. Turn engine off and operate control levers several times to relieve hydraulic pressure. Disconnect and cap hose fitting connected to rod end of sideshift cylinder assembly.

**CAUTION**

Do not place shift control lever in RIGHT position in the following steps; hydraulic oil will flow out of disconnected hose fitting.

- Start engine and operate at idle speed.
- Place SHIFT control lever in LEFT position and hold while an assistant checks for hydraulic oil leakage at side shift cylinder assembly port from which fitting was disconnected.
  - Remove sideshift cylinder assembly and repair piston assembly (WP 0264) if hydraulic oil leakage is observed.
  - If hydraulic oil leakage is not observed at sideshift cylinder assembly port, remove and repair control valve (WP 0262).

---

<b>MALFUNCTION</b>
<b>TEST OR INSPECTION</b>
<b>CORRECTIVE ACTION</b>

---

**5. UNABLE TO TILT LOAD (ALL OTHER FUNCTIONS NORMAL).****NOTE**

After completion of each check, turn engine off.

- Step 1. Check tilt cylinder assemblies for hydraulic oil leakage.
- If hydraulic oil leakage at tilt cylinder assemblies is observed, remove and repair it (WP 0263).
  - If hydraulic oil leakage is not observed at tilt cylinder assemblies, proceed to step 2.
- Step 2. Check hose assemblies between tilt cylinder assemblies and control valve for hydraulic oil leakage.
- If hydraulic oil leakage is observed at hose assemblies, replace leaking hose assemblies (WP 0195, WP 0196, and WP 0197).
  - If hydraulic oil leakage is not observed, proceed to step 3.
- Step 3. Check control valve for hydraulic oil leakage.
- If hydraulic oil leakage is observed at control valve, remove and repair it (WP 0262).
  - If hydraulic oil leakage is not observed, proceed to step 4.
- Step 4. Crack (loosen) fittings shown at side. Start engine and operate at idle speed. Place lift control lever in RAISE position until forks are three feet from ground. Place tilt control lever in FWD position and check if hydraulic oil flows from loosened fittings; place tilt control lever in REAR position and check if hydraulic oil flows from loosened fittings.
- If hydraulic oil does not flow from loosened fittings, replace control valve (WP 0262).
  - If hydraulic oil flows from fittings, proceed to step 5 (tighten fittings loosened above).

---

MALFUNCTION
TEST OR INSPECTION
CORRECTIVE ACTION

---

**5. UNABLE TO TILT LOAD (ALL OTHER FUNCTIONS NORMAL) (CONTINUED).**

- Step 5. Start engine and operate at idle speed. Place tilt control lever in FWD position until mast assembly is tilted fully forward. Turn engine off and operate control levers several times to relieve hydraulic pressure. Disconnect and cap hose fitting connected to rod end of tilt cylinder assembly.

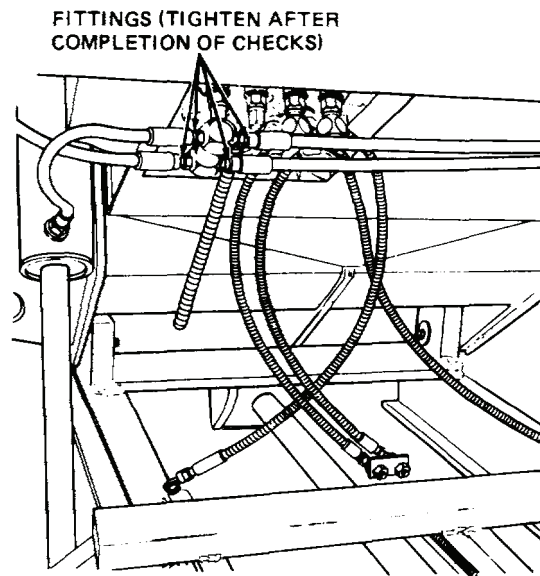

TA127501

**CAUTION**

Do not place tilt control lever in REAR position in the following steps. Hydraulic oil will flow out of disconnected hose fitting.

- Start engine and operate at idle speed.
- Place tilt control lever in FWD position and hold while an assistant checks for hydraulic oil leakage at tilt cylinder assembly port from which fitting was disconnected.
- Repeat for other tilt cylinder assembly.
  - Remove tilt cylinder assembly and repair piston assembly (WP 0263) if hydraulic oil leakage is observed.
  - If hydraulic oil leakage is not observed, remove and repair control valve (WP 0262).

---

**MALFUNCTION**  
**TEST OR INSPECTION**  
**CORRECTIVE ACTION**

---

**6. TILT CYLINDER ASSEMBLIES OPERATION SLUGGISH.****NOTE**

After completion of each check, turn engine off.

- Step 1. Check pressure relief valve setting (WP 0172, steps 20 through 22).
- If pressure relief valve setting is not correct, adjust for proper setting (WP 0172, step 23).
  - If pressure relief valve setting is okay, proceed to step 2.
- Step 2. Perform step 5 of MALFUNCTION 5 in this work package.  
Same as step 5 of MALFUNCTION 5 in this work package.

**7. UNABLE TO ROTATE LOAD (ALL OTHER FUNCTIONS NORMAL).****NOTE**

After completion of each check, turn engine off.

- Step 1. Check rotation cylinder assembly for hydraulic oil leakage.
- If rotation cylinder assembly is leaking hydraulic oil, remove and repair (WP 0265).
  - If rotation cylinder assembly is not leaking hydraulic oil, proceed to step 2.
- Step 2. Check hose assemblies between rotation cylinder assembly and control valve for hydraulic oil leakage.
- If hose assemblies are leaking hydraulic oil, replace (WP 0195, WP 0196, and WP 0197).
  - If hose assemblies are okay, proceed to step 3.

---

**MALFUNCTION**  
**TEST OR INSPECTION**  
**CORRECTIVE ACTION**

---

**7. UNABLE TO ROTATE LOAD (ALL OTHER FUNCTIONS NORMAL) (CONTINUED).**

- Step 3. Check control valve for hydraulic oil leakage.
- If control valve is leaking hydraulic oil, remove and repair it (WP 0262).
  - If control valve is okay, proceed to step 4.
- Step 4. Crack (loosen) fittings shown.
- Start engine and operate at idle speed.
  - Place lift control lever in RAISE position until forks are three feet from ground.
  - Place rotate control lever in CCW position and check if hydraulic oil flows from fittings; place rotate control lever in CW position and check if hydraulic oil flows from fittings.

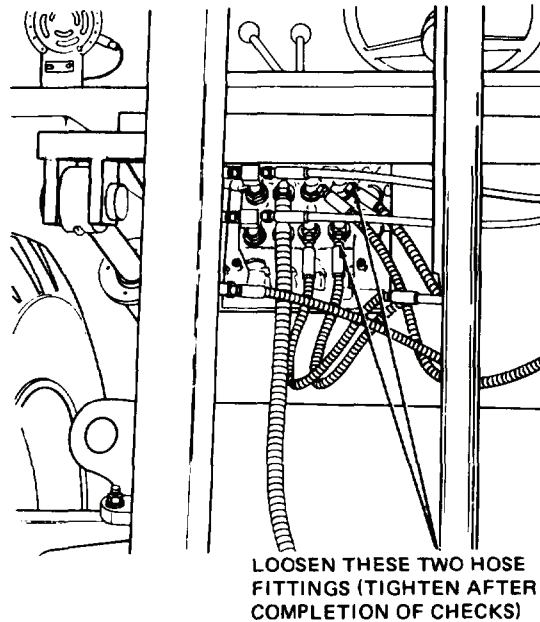

- If hydraulic oil does not flow from fittings, remove and repair control valve (WP 0265).
- If hydraulic oil flows from fittings, remove and repair rotation cylinder assembly (WP 0265) (tighten fittings loosened above).



---

<b>MALFUNCTION</b>
<b>TEST OR INSPECTION</b>
<b>CORRECTIVE ACTION</b>

---

**8. ROTATION OPERATION SLUGGISH.****NOTE**

After completion of each check, lower forks until resting on ground. Then, turn engine off.

- Step 1. Check pressure relief valve setting (WP 0172, steps 20 through 22).
- a. If pressure relief valve setting is not correct, adjust for proper setting (WP 0172, step 23).
  - b. If pressure relief valve setting is okay, proceed to step 2.
- Step 2. Start engine and operate at idle speed.
- a. Place lift control lever in RAISE position until forks are three feet from ground.
  - b. Place rotate control lever in CCW position until forks are in extreme CCW position.
  - c. Turn engine off and operate control levers several times to relieve hydraulic pressure.
  - d. Disconnect and cap hose fitting connected to rod end of rotation cylinder assembly.

**CAUTION**

Do not place rotate control lever in CW position in following steps; hydraulic oil will flow out of disconnected hose fitting.

- e. Start engine and operate at idle speed.
- f. Place rotate control lever in CCW position and hold while an assistant checks for hydraulic oil leakage at rotation cylinder assembly port from which fitting was disconnected.
- g. Remove and repair rotation cylinder assembly (repair or replace piston assembly) (WP 0265) if hydraulic oil leakage is observed.
- h. If hydraulic oil leakage is not observed, remove and repair control valve (WP 0265).

**END OF WORK PACKAGE**



**CHAPTER 4**  
**ORGANIZATIONAL MAINTENANCE INSTRUCTIONS**



---

## ORGANIZATIONAL MAINTENANCE INSTRUCTIONS

### SERVICE UPON RECEIPT

#### Handling New Equipment, Servicing New Equipment, Initial Checkout and Adjustment, Movement to New Site

---

#### HANDLING NEW EQUIPMENT

1. Unloading Instructions. Vehicle is shipped unboxed and mobile on railcar with tiedowns over front and rear axles.
  - a. Remove blocking from front, rear, and sides of vehicle.
  - b. Perform unpacking (step 2), lubrication (step 3 in *Servicing New Equipment* in this work package), and service check (step 2a in *Initial Checkout and Adjustment* in this work package).
  - c. Remove tiedowns and remove vehicle from railcar.
2. Unpacking. Remove tape, banding, paper, and other packing materials. If necessary, remove tape from exhaust pipe.

#### END OF TASK

#### SERVICING NEW EQUIPMENT



WARNING



Solvent cleaning compound MIL-PRF-680 Type III is an environmentally compliant and low toxic material. However, it may be irritating to the eyes and skin. Use protective gloves and goggles. Use in well-ventilated areas. Keep away from open flames and other sources of ignition. Failure to do so may result in injury or death to personnel.

1. Removal of Protective Compounds. Remove preservative compounds from metal surfaces with solvent cleaning compound. Check and ensure that all fill openings are clear.
2. Cleaning. Clean all dust and dirt from seat, instrument panel, wiring, engine, and radiator.
3. Lubrication. Lubricate vehicle in accordance with LO 10-3930-638-12.

#### END OF TASK

**INITIAL CHECKOUT AND ADJUSTMENT**

1. Inspection.
  - a. Inspect equipment for damage incurred during shipment. If equipment has been damaged, report the damage on DD Form 361, *Packaging Improvement Report*.
  - b. Check equipment against packing slip to see if shipment is complete. Report all discrepancies in accordance with instructions of PAM 750-8.
  - c. Check to see whether equipment has been modified.



If NBC exposure is suspected, all air filter media should be handled by personnel wearing protective equipment. Consult your unit NBC Officer or NBC NCO for appropriate handling and disposal procedures.

- d. Check air cleaner for damage.
  - e. Check gages and instruments on instrument panel for broken glass and other damage.
  - f. Check control levers for bent or broken condition.
  - g. Check engine accessories for loose connections and insecure mounting.
  - h. Check wiring for loose connections, damaged insulation, and broken wires.
  - i. Check fittings, lines, and hoses for cracks, loose connections, and broken or missing parts.
  - j. Ensure all drain plugs are securely tightened.
2. Service Check.
    - a. Remove shipping klik pin and shipping lock pin from holes in front and rear chassis and stow in storage area as shown in Figure 1.

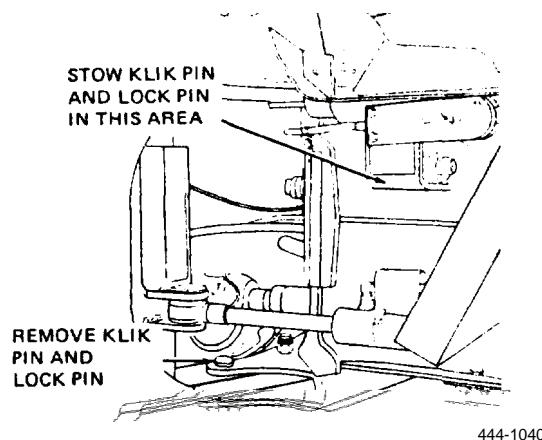

Figure 1. Service Check.

- b. Perform *Before Operation PMCS* (TM 10-3930-638-10).

**END OF TASK**

**MOVEMENT TO NEW SITE**

1. Driving. The vehicle may be moved under its own power without any special preparation or may be transported by a suitable truck and flatbed trailer. If transported on a flatbed trailer:

**WARNING**

Be sure ramp is securely fastened to flatbed trailer to prevent injury to personnel or damage to equipment.

- a. Place ramps between flatbed trailer and ground.

**NOTE**

Ramps should not provide a grade of more than 40 percent.

- b. Drive vehicle up ramps and position on flatbed trailer. Turn engine off and apply parking brake.
  - c. Install blocking at front, rear, and sides of vehicle.
  - d. Install tiedowns at front and rear axles (refer to data plate number 20, WP 0002).
2. Towing. Vehicle is towed rearward using tow bar and chains located on rear. Special procedures shall be performed prior to towing operation. Refer to TM 10-3930-638-10, *Preparation for Movement*, for these procedures.

**END OF TASK****END OF WORK PACKAGE**





---

## ORGANIZATIONAL MAINTENANCE INSTRUCTIONS

### PREVENTIVE MAINTENANCE CHECKS AND SERVICES (PMCS) INTRODUCTION

---

#### GENERAL

To ensure the forklift truck is ready for operation at all times, it must be inspected within designated intervals so defects may be discovered and corrected before they result in serious damage or failure. All deficiencies and shortcomings as well as the corrective action taken, will be recorded, on DA Form 2404 at the earliest possible opportunity.

#### EXPLANATION OF TABLE ENTRIES

1. **Item Number (Item No.) Column.** Numbers in this column are for reference. When completing DA Form 2404 or DA Form 5988-E (*Equipment Inspection and Maintenance Worksheet*), include the item number for the check/service indicating a fault. Item numbers also appear in the order that you must perform checks and services for the interval listed.
2. **Interval Column.** This column tells you when you must perform the procedure in the Procedure column.
  - a. *Before* procedures must be done immediately before you operate the forklift truck.
  - b. *During* procedures must be done while you are operating the forklift truck.
  - c. *After* procedures must be done immediately after you have operated the forklift truck.
  - d. *Weekly* procedures must be done once each week.
  - e. *Monthly* procedures must be done once each month.
3. **Man Hours.** Not applicable.
4. **Location, Item to Check/Service Column.** This column provides the location and item to be checked or serviced.

#### NOTE

The WARNINGS and CAUTIONS appearing in your PMCS table should always be observed. WARNINGS and CAUTIONS appear before applicable procedures. You must observe these WARNINGS to prevent serious injury to yourself and others, and CAUTIONS to prevent your equipment from being damaged.

5. **Procedure Column.** This column gives the procedure you must perform to check or service the item listed in the Item to Check/Service column, to know if the equipment is ready or available for its intended mission. You must perform the procedure at the time stated in the interval column.

## GENERAL PMCS PROCEDURES

- a. Always perform PMCS in the same order so it gets to be a habit. Once you have had some practice, you will spot anything wrong in a hurry. If the vehicle does not perform as required, refer to the appropriate troubleshooting procedure in Chapter 2.
- b. If anything looks wrong and you cannot fix it, write it on your DA Form 2404 or DA Form 5988-E. If you find something seriously wrong, IMMEDIATELY report it to your supervisor.
- c. Before performing preventive maintenance, read all the checks required for the applicable interval and prepare all that is needed to make all the checks. You will always need a rag or two.



WARNING



- Solvent cleaning compound MIL-PRF-680 Type III is an environmentally compliant and low toxic material. However, it may be irritating to the eyes and skin. Use protective gloves and goggles. Use in well-ventilated areas. Keep away from open flames and other sources of ignition. Failure to do so may result in injury or death to personnel.
  - Particles blown by compressed air are hazardous. DO NOT exceed 15 PSI (103 kPa) nozzle pressure when drying parts with compressed air. Use a maximum of 30 PSI (207 kPa) when cleaning components. DO NOT direct compressed air against human skin. Make sure air stream is directed away from user and other personnel in the area. To prevent injury, user must wear protective goggles or face shield. Failure to follow this warning may result in injury to personnel.
- d. **Keep It Clean.** Dirt, grease, oil, and debris get in the way and may cover up a serious problem. Clean as you work and as needed. Use solvent cleaning compound to clean metal surfaces. Use soap and water when you clean rubber or plastic material.
  - e. **Bolts, Nuts, and Screws.** Check bolts, nuts, and screws for obvious looseness, missing, bent, or broken condition. You cannot try them all with a tool, but look for chipped paint, bare metal, or rust around bolt heads. Tighten any that you find loose.
  - f. **Welds.** Look for loose or chipped paint, rust, or gaps where parts are welded together. If you find a bad weld, report it to your supervisor.
  - g. **Electric Wires and Connectors.** Look for cracked or broken insulation, bare wires, and loose or broken connectors. Reconnect loose connectors. Ensure that wires are in good condition.
  - h. **Hoses and Fluid Lines.** Look for wear, damage, and signs of leaks. Check for loose clamps and fittings. Wet spots indicate leaks, but a stain around a fitting or connector can also mean a leak. If a leak comes from a loose fitting or connector, notify your supervisor. If something is broken or worn out, either correct it or report it to Direct Support Maintenance.
  - i. **Fluid Leakage.** It is necessary for you to know how fluid leakage affects the status of your vehicle. The following are definitions of the types/classes of leakage you need to know to be able to determine the status of your vehicle. Learn and be familiar with them, and remember: when in doubt, notify your supervisor.

**GENERAL PMCS PROCEDURES - CONTINUED****CAUTION**

Operation is allowable with Class I and Class II leakage, EXCEPT for fuel, where NO leaks are allowed. WHEN IN DOUBT, NOTIFY YOUR SUPERVISOR. When operating with Class I or Class II leaks, check fluid levels more frequently. Class III leaks must be reported immediately to your supervisor. Failure to do this will result in damage to vehicle and/or components.

**NOTE**

Notify your supervisor of any leaks you cannot fix.

**Leakage Definitions for PMCS**

Class I	Leakage indicated by wetness or discoloration, but not great enough to form drops.
Class II	Leakage great enough to form drops, but not enough to cause drops to drip from the item being checked/inspected.
Class III	Leakage great enough to form drops that fall from the item being checked/inspected.





**END OF WORK PACKAGE**



## ORGANIZATIONAL MAINTENANCE INSTRUCTIONS

### PREVENTIVE MAINTENANCE CHECKS AND SERVICES (PMCS) PROCEDURES

ITEM NO.	INTERVAL	MAN-HOURS	LOCATION	PROCEDURE
			ITEM TO CHECK/SERVICE	
<b>NOTE</b>				
				<ul style="list-style-type: none"> <li>Review all WARNINGS, CAUTIONS, and NOTES before performing PMCS and operating the vehicle.</li> <li>Perform Operator PMCS prior to or in conjunction with Organizational PMCS if:                             <ol style="list-style-type: none"> <li>There is a delay between daily operation of the vehicle and Organizational PMCS.</li> <li>The regular operator is not assisting.</li> </ol> </li> <li>Unless otherwise indicated, perform PMCS with vehicle parked on level ground, parking brake applied, transmission in neutral, forks lowered to ground, wheels blocked, and engine shut down.</li> <li>If leakage is detected during performance of PMCS, further investigation is required to determine location and cause of leak.</li> </ul>
1	Weekly		Brake Master Cylinder	<ol style="list-style-type: none"> <li>Check brake fluid level. Add brake fluid (Item 23, WP 0309) to within 1/2 in. (13 mm) of fill plug opening.</li> <li>Check interior of master cylinder cap for rust. Clean as necessary and coat with brake fluid.</li> </ol>
2	Quarterly		Air Cleaner	<div style="display: flex; align-items: center; justify-content: center; margin-bottom: 10px;"> <div style="margin-right: 5px;"><b>WARNING</b></div> </div> <ul style="list-style-type: none"> <li>If NBC exposure is suspected, all air filter media should be handled by personnel wearing protective equipment. Consult your NBC Officer or NBC NCO for appropriate handling or disposal procedures.</li> <li>Particles blown by compressed air are hazardous. DO NOT exceed 30 PSI (207 kPa) nozzle pressure when cleaning parts with compressed air. DO NOT direct compressed air against human skin. Failure to follow this warning may result in injury to personnel. Make sure air stream is directed away from user and other personnel in the area. To prevent injury, user must wear protective goggles or face shield.</li> </ul> <p>Remove elements and blow from inside out with low-pressure air. Replace if defective. Reset contamination indicator.</p>
3	Quarterly		Parking Brake Linkage	<p>Check linkage for loose or missing hardware. If adjusting knob does not tighten enough, adjust linkage.</p>

ITEM NO.	INTERVAL	MAN-HOURS	LOCATION ITEM TO CHECK/ SERVICE	PROCEDURE
4	Quarterly		Service Brakes	a. Inspect brake pads. If thickness is 3/32 in. (2.4 mm) or less, or if brake pads are contaminated, replace (WP 0163). b. Ensure brake pedal has 1/4 to 1 in. (6.4 to 25.4 mm) free travel and is at least 2 in. (50 mm) from floor when fully applied. c. Inspect wheel cylinders for cracks, leaks, and broken end. Inspect brake shoe for cracks. Inspect backing plates for bends, cracks, and loose rivets (WP 0163). d. Inspect entire hydraulic brake system for leaks, cracked lines, and worn hoses (WP 0164). Replace all defective parts as required. e. Adjust service brakes (WP 0163).
5	Quarterly		Axles	<div style="display: flex; align-items: center; margin-bottom: 10px;">   <div style="margin: 0 10px;"><b>WARNING</b></div>   </div> <ul style="list-style-type: none"> <li>Solvent cleaning compound MIL-PRF-680 Type III is an environmentally compliant and low toxic material. However, it may be irritating to the eyes and skin. Use protective gloves and goggles. Use in well-ventilated areas. Keep away from open flames and other sources of ignition. Failure to do so may result in injury or death to personnel.</li> <li>Particles blown by compressed air are hazardous. DO NOT exceed 15 PSI (103 kPa) nozzle pressure when drying parts with compressed air. DO NOT direct compressed air against human skin. Failure to follow this warning may result in injury to personnel. Make sure air stream is directed away from user and other personnel in the area. To prevent injury, user must wear protective goggles or face shield.</li> </ul> <p>Service breathers. Remove and immerse in solvent cleaning compound and dry with compressed air.</p>
6	Quarterly		Chassis	Check chassis, brackets, and mounting and ensure that they are in good condition and secure.
7	Quarterly		Sideshift Frame	Ensure chain pulleys are securely fastened. Check sideshift bars for excessive wear, deformation, and bent condition.
8	Quarterly		Spark Arresting Muffler	Blow carbon and soot from muffler (WP 0076 or WP 0077).

ITEM NO.	INTERVAL	MAN-HOURS	LOCATION	PROCEDURE
			ITEM TO CHECK/SERVICE	
9	Quarterly		Batteries	<div style="display: flex; align-items: center; justify-content: center;">  </div> <p><b>WARNING</b></p> <ul style="list-style-type: none"> <li>• To avoid injury, eye protection and acid-resistant gloves must be worn when working around batteries. DO NOT smoke, use open flame, make sparks, or create other ignition sources around batteries. If a battery is giving off gases, it can explode and cause injury to personnel. Remove all jewelry such as rings, ID tags, watches, and bracelets. If jewelry or a tool contacts a battery terminal, a direct short will result in instant heating or electric shock, damage to equipment, and injury to personnel.</li> <li>• Sulfuric acid contained in batteries can cause serious burns. If battery corrosion or electrolyte makes contact with skin, eyes or clothing, take immediate action to stop the corrosive burning effects. Failure to follow these procedures may result in injury or death to personnel.             <ol style="list-style-type: none"> <li>a. <u>Eyes</u>. Flush with cold water for no less than 15 minutes and seek medical attention immediately.</li> <li>b. <u>Skin</u>. Flush with large amounts of cold water until all acid is removed. Seek medical attention as required.</li> <li>c. <u>Internal</u>. If corrosion or electrolyte is ingested, drink large amounts of water or milk. Follow with milk of magnesia, beaten egg, or vegetable oil. Seek medical attention immediately.</li> <li>d. <u>Clothing/Equipment</u>. Wash area with large amounts of cold water. Neutralize acid with baking soda or household ammonia.</li> </ol> </li> </ul> <p style="text-align: center;"><b>CAUTION</b></p> <p>In cold weather operations, charge battery immediately after adding water to combine the water with battery electrolyte to prevent freezing. Be careful not to overfill when servicing batteries.</p> <ol style="list-style-type: none"> <li>a. Test battery to determine cell condition (TM 9-6140-200-14).</li> <li>b. Clean battery top and terminals. Ensure all connections are tight.</li> </ol>
10	Semi-Annually		Fuel Filters	Replace in-line, primary, secondary, and injection pump inlet filters.
11	Annually		Fuel Strainer	Remove strainer from fuel tank. Clean, inspect, and replace if clogged, torn, or deformed.
12	Annually		Cooling System	Drain, flush, and refill radiator in accordance with TB 750-651.
13	Annually		Parking Brake Assembly	Check linings. If thickness is 1/8 in. (3 mm) or less, replace.

END OF WORK PACKAGE





## ORGANIZATIONAL MAINTENANCE INSTRUCTIONS

### FLYWHEEL INSPECTION (MODEL 207)

#### Inspection

#### INITIAL SETUP

##### Maintenance Level

Organizational

##### Materials/Parts

None

##### Tools and Special Tools

Tool kit, general mechanic's (Item 15, WP 0309)

##### Equipment Condition

Engine OFF

Left side panel removed (WP 0179)

#### INSPECTION

1. Position dust cover away from access hole of flywheel housing (Figure 1).
2. Inspect teeth of ring gear.
3. Notify General Support Maintenance if any ring gear teeth are missing or broken.
4. Using screwdriver inserted in access hole, rotate ring gear to check all gear teeth.

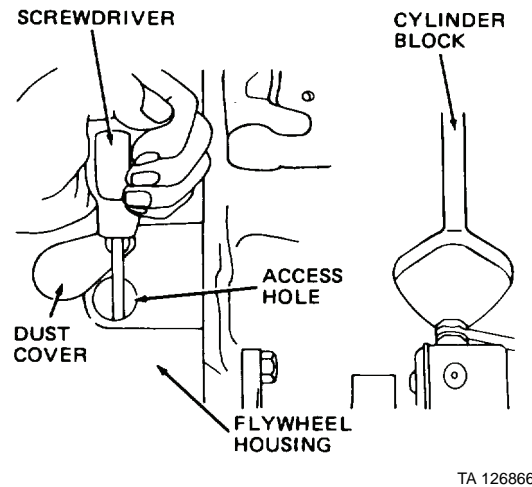

Figure 1. Flywheel Housing.

5. Position dust cover over access hole.

#### END OF TASK

#### END OF WORK PACKAGE



# ORGANIZATIONAL MAINTENANCE INSTRUCTIONS

## FLYWHEEL INSPECTION (MODEL 4-390)

### Inspection

#### INITIAL SETUP

**Maintenance Level**

Organizational

**Materials/Parts**

Rag, wiping (Item 26, WP 0310)

**Tools and Special Tools**

Tool kit, general mechanic's (Item 15, WP 0309)  
 Shop equipment, common no. 1 (Item 2, WP 0309)  
 Engine turn-over tool

**Equipment Condition**

Vehicle parked on level surface  
 Engine OFF  
 Parking brake applied  
 Right side panel removed (WP 0179)

#### INSPECTION

1. Remove two plastic plugs from flywheel housing (Figure 1).

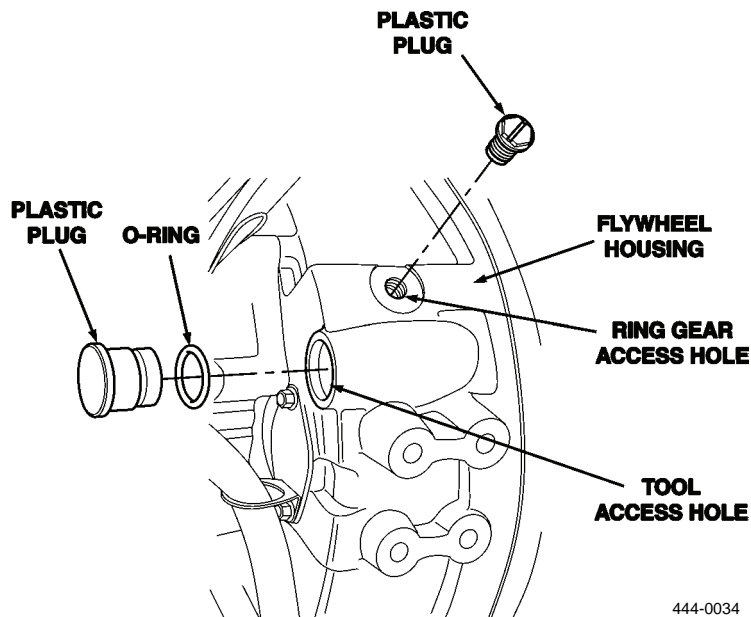
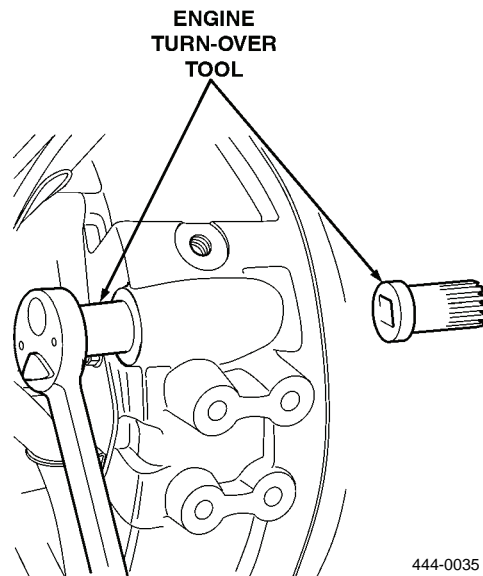

Figure 1. Flywheel Housing.

**INSPECTION - CONTINUED**

2. Use engine turn-over tool with socket wrench and insert into tool access hole to mesh with teeth of ring gear (Figure 2).
3. Rotate engine turn-over tool to inspect condition of all ring gear teeth. Notify General Support Maintenance if ring gear teeth are broken or missing.

**Figure 2. Engine Turn-Over Tool.**

4. Remove engine turn-over tool from flywheel housing.
5. Install two plastic plugs on flywheel housing (Figure 3).

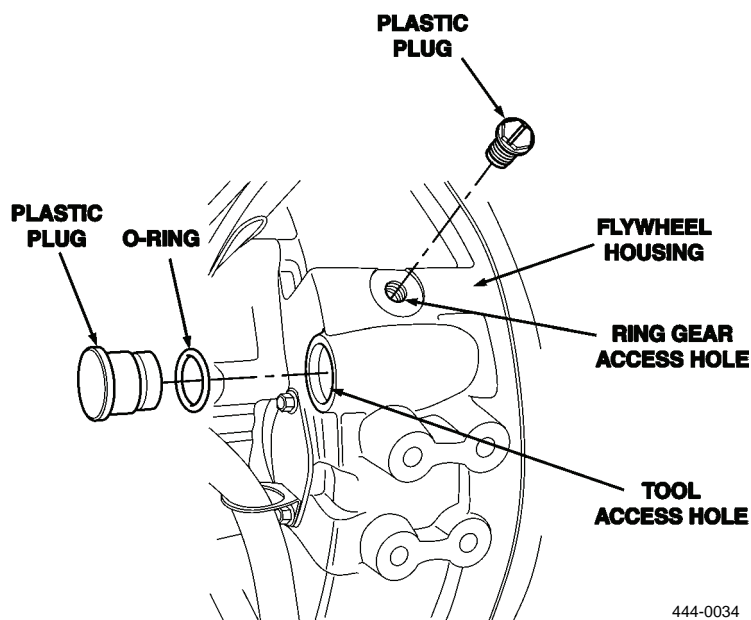
**Figure 3. Plastic Plugs.****END OF TASK****END OF WORK PACKAGE**

# ORGANIZATIONAL MAINTENANCE INSTRUCTIONS

## DRAINING AND FILLING ENGINE CRANKCASE (MODEL 207)

### Draining, Filling

#### INITIAL SETUP

##### Maintenance Level

Organizational

##### Tools and Special Tools

Tool kit, general mechanic's (Item 15, WP 0309)

Container

##### Materials/Parts

Rag, wiping (Item 26, WP 0310)

Lubricating oil, 7 qt (LO 10-3930-638-12)

##### Materials/Parts - Continued

Gasket

##### References

WP 0051

##### Equipment Condition

Engine OFF

Left side panel removed (WP 0179)

#### DRAINING

1. Remove drain plug and gasket from engine oil pan and allow oil to drain into container (Figure 1). Discard gasket if damaged.

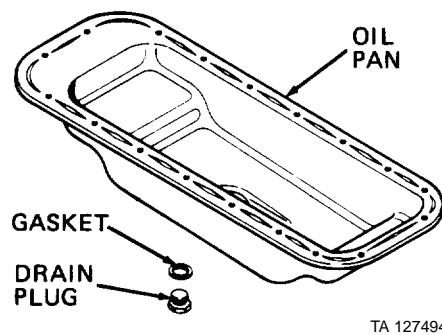

**Figure 1. Engine Oil Pan.**

2. Install drain plug and gasket in engine oil pan. Tighten drain plug.
3. To replace engine oil filter, refer to WP 0051.

#### END OF TASK

**FILLING**

1. Remove engine oil level dipstick from right side of engine (Figure 2).

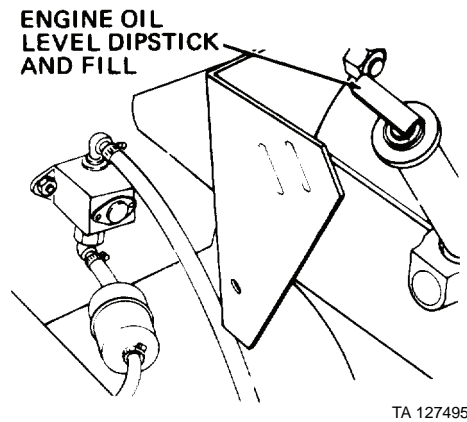

**Figure 2. Dipstick.**

2. Add engine oil to engine. Refer to LO 10-3930-638-12.
3. Start engine and allow engine to run for several minutes. Stop engine and check for proper oil level using dipstick. Add oil if necessary.
4. Check for oil leaks at drain plug. Tighten drain plug if necessary.
5. Install dipstick.

**END OF TASK****END OF WORK PACKAGE**

## ORGANIZATIONAL MAINTENANCE INSTRUCTIONS

### DRAINING AND FILLING ENGINE CRANKCASE (MODEL 4-390)

#### Draining, Filling

#### INITIAL SETUP

##### Maintenance Level

Organizational

##### References

WP 0052

##### Tools and Special Tools

Tool kit, general mechanic's (Item 15, WP 0309)

Container

##### Equipment Condition

Engine OFF

Oil hot from engine operation

Right side panel removed (WP 0179)

##### Materials/Parts

Rag, wiping (Item 26, WP 0310)

Lubricating, oil, 10 qt (LO 10-3930-638-12)

#### DRAINING

#### NOTE

Consult your unit/local hazardous waste disposal center or safety office for local regulatory guidance for disposal of oil. If further information is needed, please contact the Army Environmental Hotline at 1-800-872-2845.

1. Remove drain plug and gasket from engine oil pan and allow oil to drain into container (Figure 1). Discard seal if damaged.
2. Install drain plug and gasket in engine oil pan. Tighten drain plug.

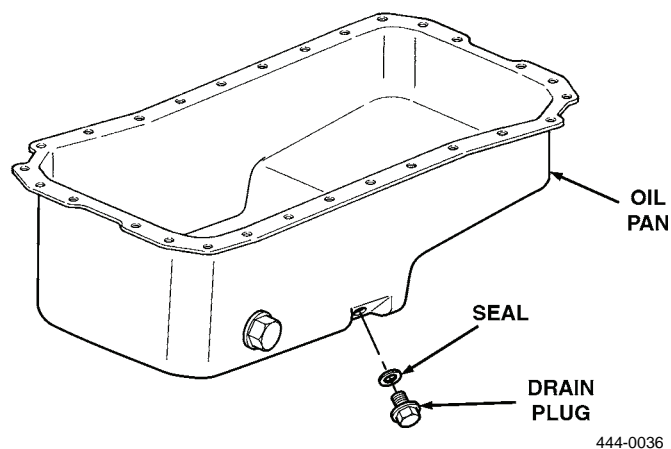

Figure 1. Engine Oil Pan.

3. To replace engine oil filter, refer to WP 0052.

#### END OF TASK

**FILLING**

1. Remove engine oil level dipstick from right side of engine (Figure 2).

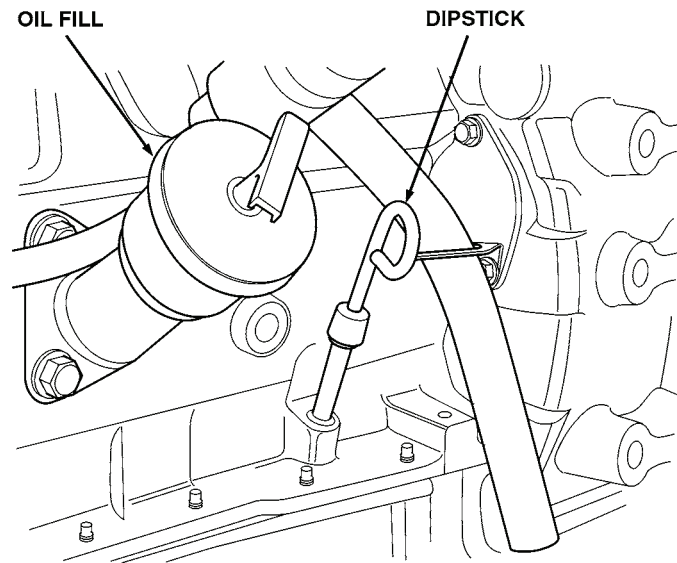

444-0037

**Figure 2. Dipstick.**

2. Add engine oil to engine. Refer to LO 10-3930-638-12.
3. Start engine and allow engine to run for several minutes. Stop engine and check for proper oil level using dipstick. Add oil if necessary.
4. Check for oil leaks at drain plug. Tighten drain plug if necessary.
5. Install dipstick.

**END OF TASK****END OF WORK PACKAGE**



---

## ORGANIZATIONAL MAINTENANCE INSTRUCTIONS

### OIL FILTER REPLACEMENT (MODEL 207)

#### Removal, Installation

---

#### INITIAL SETUP

**Maintenance Level**

Organizational

**Tools and Special Tools**

Tool kit, general mechanic's (Item 15, WP 0309)

Shop equipment, common no. 1 (Item 2, WP 0309)

**Materials/Parts**

Rag, wiping (Item 26, WP 0310)

Oil filter

**Equipment Condition**

Engine OFF

Engine crankcase drained (WP 0049)

---

#### REMOVAL

Remove engine oil filter from left rear of engine (Figure 1). Discard oil filter.

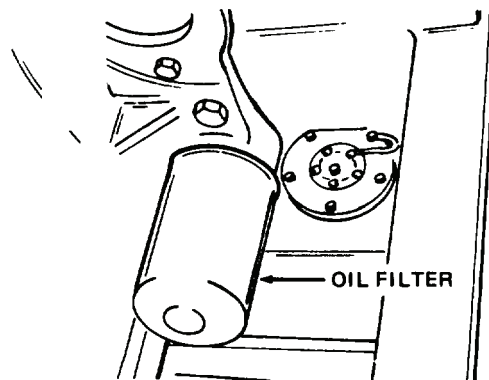

TA 126867

Figure 1. Engine Oil Filter.

#### END OF TASK

#### INSTALLATION

1. Apply thin coat of clean engine oil to gasket of new oil filter.
2. Install new oil filter on engine until gasket of oil filter contacts engine.
3. Tighten oil filter an additional one-half to three-quarters of a turn.
4. Fill engine crankcase with engine oil (WP 0049).
5. Check for oil leak at gasket of oil filter.

#### END OF TASK

#### END OF WORK PACKAGE



---

## ORGANIZATIONAL MAINTENANCE INSTRUCTIONS

### OIL FILTER REPLACEMENT (MODEL 4-390)

#### Removal/Installation

---

#### INITIAL SETUP

**Maintenance Level**

Organizational

**Tools and Special Tools**

Tool kit, general mechanic's (Item 15, WP 0309)

Clamping-type oil filter wrench

**Materials/Parts**

Rag, wiping (Item 26, WP 0310)

Oil filter

**References**

LO 10-3930-638-12

**Equipment Condition**Engine crankcase drained (WP 0050)

---

#### REMOVAL/INSTALLATION

1. Use filter wrench and turn oil filter counterclockwise to remove oil filter (Figure 1). Discard oil filter.
2. Install new oil filter. Apply thin coat of clean engine oil to gasket of new oil filter. Install until gasket contacts base, then turn one-half to three quarters of a turn to obtain proper seal.

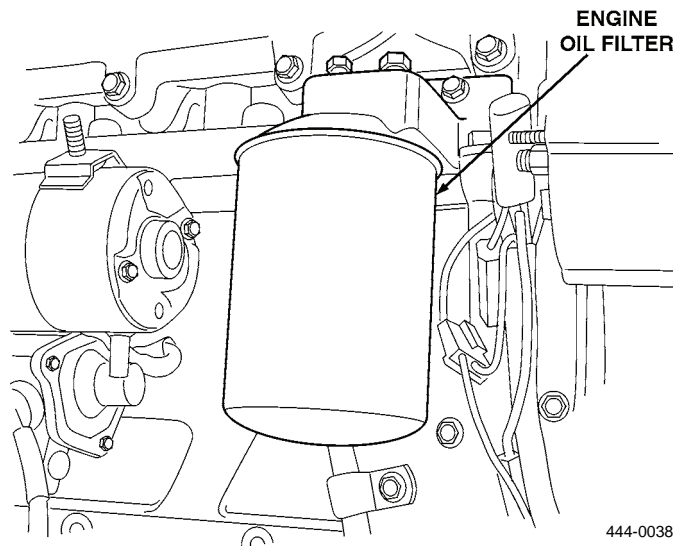

**Figure 1. Engine Oil Filter.**

3. Install drain plug on engine oil pan and tighten securely.
4. Fill engine with engine oil (LO 10-3930-638-12). Start engine and run for several minutes to charge lubrication system. Check for oil leaks at oil filter base.

#### END OF TASK

#### END OF WORK PACKAGE



---

## ORGANIZATIONAL MAINTENANCE INSTRUCTIONS

### INTAKE MANIFOLD REPLACEMENT (MODEL 207)

#### Removal, Cleaning, Inspection, Installation

---

#### INITIAL SETUP

**Maintenance Level**

Organizational

**Tools and Special Tools**

Tool kit, general mechanic's (Item 15, WP 0309)

Shop equipment, common no. 1 (Item 2, WP 0309)

**Materials/Parts**

Brush, wire (Item 8, WP 0310)

Cleaning compound, solvent (Item 10, WP 0310)

Rag, wiping (Item 26, WP 0310)

Gasket

Intake manifold gasket

**References**

FM 3-3

FM 3-3-1

FM 3-5

**Equipment Condition**

Engine OFF

Left side panel removed (WP 0179)

Air cleaner hose disconnected from air cleaner  
(WP 0061)

Left-rear fender removed (WP 0178)

Left hood panel removed (WP 0182)

---

**REMOVAL**

1. Disconnect tube (Figure 1, Item 1) from elbow (Figure 1, Item 2) at left side of engine.
2. Remove elbow (Figure 1, Item 2) and filter fitting (Figure 1, Item 3) from intake manifold (Figure 1, Item 14)

**WARNING**

- If NBC exposure is suspected, personnel wearing protective equipment must handle all air cleaner media. Consult your NBC Officer or NBC NCO for appropriate handling or disposal procedures.
  - Refer to FM 3-3, *Chemical and Biological Contamination Avoidance*, FM 3-5, *NBC Decontamination*, and FM 3-3-1, *Nuclear Contamination Avoidance*.
  - NBC contaminated filters must be handled using adequate precautions and must be disposed of by trained personnel.
  - Failure to follow these warnings may cause injury or death to personnel.
3. Loosen hose clamp (Figure 1, Item 4) and disconnect air cleaner hose (Figure 1, Item 5) from intake manifold (Figure 1, Item 14).
  4. Disconnect delivery tube (Figure 1, Item 6) from spray nozzle (Figure 1, Item 7).
  5. Remove spray nozzle (Figure 1, Item 7), washer (Figure 1, Item 8), adapter (Figure 1, Item 9), and gasket (Figure 1, Item 10) from intake manifold (Figure 1, Item 14). Discard gasket.

**CAUTION**

When removing gasket, ensure gasket material does not fall into cylinder head ports. Damage to engine may result from foreign material falling into ports.

6. Remove five nuts (Figure 1, Item 11), three washers (Figure 1, Item 12), two washers (Figure 1, Item 13), intake manifold (Figure 1, Item 14), and gasket (Figure 1, Item 15) from engine. Discard gasket.

REMOVAL - CONTINUED

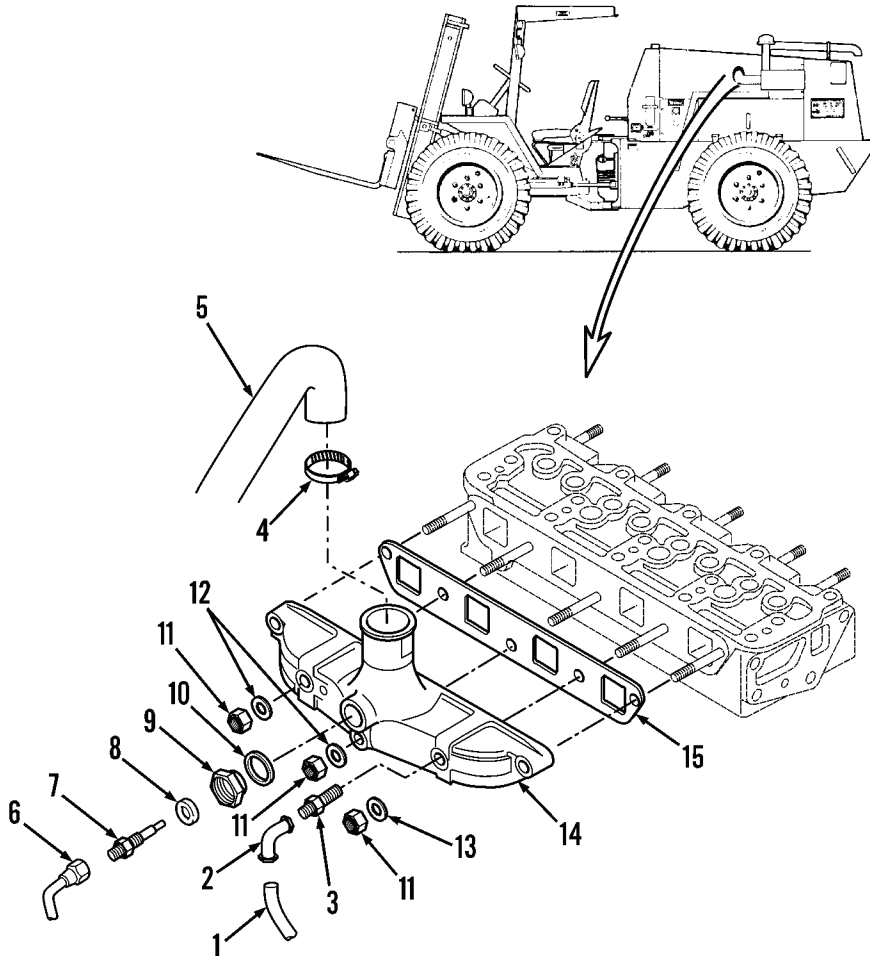

444-1022

Figure 1. Intake Manifold.

END OF TASK

**CLEANING****WARNING**

- Solvent cleaning compound MIL-PRF-680 Type III is an environmentally compliant and low toxic material. However, it may be irritating to the eyes and skin. Use protective gloves and goggles. Use in well-ventilated areas. Keep away from open flames and other sources of ignition. Failure to do so may result in injury or death to personnel.
  - Particles blown by compressed air are hazardous. DO NOT exceed 15 PSI (103 kPa) nozzle pressure when drying parts with compressed air. DO NOT direct compressed air against human skin. Make sure air stream is directed away from user and other personnel in the area. To prevent injury, user must wear protective goggles or face shield. Failure to follow this warning may result in injury to personnel.
1. Clean all parts, except intake manifold, with solvent cleaning compound. Dry thoroughly with compressed air.
  2. Clean intake manifold with wire brush to remove all rust, carbon, and oxidized material. Ensure all traces of gasket material are removed.
  3. Cleaning mating surface and studs of engine cylinder head with solvent cleaning compound. Remove all traces of gasket material. Dry thoroughly with clean rags.

**END OF TASK****INSPECTION**

1. Inspect intake manifold (Figure 2, Item 14). Replace if cracked or damaged.
2. Inspect adapter (Figure 2, Item 9). Replace if internal threads are damaged.
3. Inspect cylinder head studs. If studs are broken or have damaged threads, notify Direct Support Maintenance.

**WARNING**

- If NBC exposure is suspected, personnel wearing protective equipment must handle all air cleaner media. Consult your NBC Officer or NBC NCO for appropriate handling or disposal procedures.
  - Refer to FM 3-3, *Chemical and Biological Contamination Avoidance*, FM 3-5, *NBC Decontamination*, and FM 3-3-1, *Nuclear Contamination Avoidance*.
  - NBC contaminated filters must be handled using adequate precautions and must be disposed of by trained personnel.
  - Failure to follow these warnings may cause injury or death to personnel.
4. Inspect air cleaner hose (Figure 2, Item 5). Replace if cracked or worn. Refer to WP 0061.
  5. Inspect all other parts. Replace if cracked or worn.

**END OF TASK**



**INSTALLATION**

1. Position new gasket (Figure 2, Item 15) and intake manifold (Figure 2, Item 14) on engine.
2. Install two washers (Figure 2, Item 13), three washers (Figure 2, Item 12), and five nuts (Figure 2, Item 11). Tighten nuts to 30 to 35 lb-ft (41 to 47 Nm).
3. Install new gasket (Figure 2, Item 10), adapter (Figure 2, Item 9), washer (Figure 2, Item 8), and spray nozzle (Figure 2, Item 7).
4. Connect delivery tube (Figure 2, Item 6) to spray nozzle (Figure 2, Item 7).
5. Connect air cleaner hose (Figure 2, Item 5) to intake manifold (Figure 2, Item 14). Tighten hose clamp (Figure 2, Item 4).
6. Install filter fitting (Figure 2, Item 3) and elbow (Figure 2, Item 2) on intake manifold (Figure 2, Item 14).
7. Connect tube (Figure 2, Item 1) to elbow (Figure 2, Item 2).

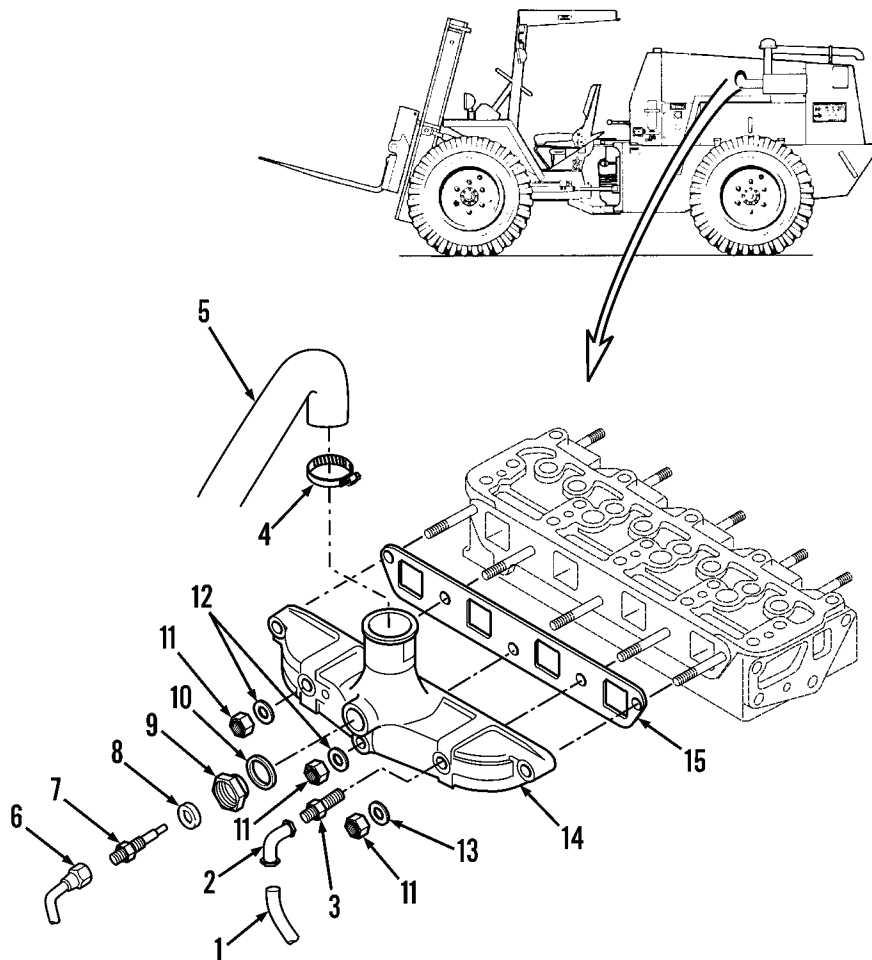

444-1022

**Figure 2. Intake Manifold.****END OF TASK****END OF WORK PACKAGE**



---

## ORGANIZATIONAL MAINTENANCE INSTRUCTIONS

### INTAKE MANIFOLD REPLACEMENT (MODEL 4-390)

Removal, Cleaning, Inspection, Installation/Replacement

---

#### INITIAL SETUP

##### Maintenance Level

Organizational

##### Tools and Special Tools

Tool kit, general mechanic's (Item 15, WP 0309)  
Shop equipment, common no. 1 (Item 2, WP 0309)

##### Materials/Parts

Cleaning compound, solvent (Item 10, WP 0310)  
Rag, wiping (Item 26, WP 0310)

##### Materials/Parts - Continued

Intake manifold gasket  
Sealing washer

##### Equipment Condition

Right side panel removed (WP 0179)  
Right fender removed (WP 0178)  
Top hood removed (WP 0181)  
Right hood support plate removed (WP 0183)  
Fuel injection lines and fittings removed (WP 0230)

---

**REMOVAL**

1. Loosen clamp (Figure 1, Item 1) on air cleaner hose (Figure 1, Item 2).

**WARNING**

If NBC exposure is suspected, all air filter media should be handled by personnel wearing protective equipment. Consult your unit NBC Officer or NBC NCO for appropriate handling or disposal procedures.

2. Disconnect air cleaner hose (Figure 1, Item 2) from intake manifold (Figure 1, Item 4) and remove hose clamp (Figure 1, Item 1).
3. Remove seven capscrews (Figure 1, Item 3) from intake manifold (Figure 1, Item 4).

**CAUTION**

When removing gasket, ensure gasket material does not fall into cylinder head ports. Damage to engine may result from foreign material falling into ports.

4. Remove intake manifold (Figure 1, Item 4) and gasket (Figure 1, Item 5) from cylinder block. Discard gasket.
5. Remove plug (Figure 1, Item 6) and sealing washer (Figure 1, Item 7) from intake manifold (Figure 1, Item 4). Discard sealing washer.

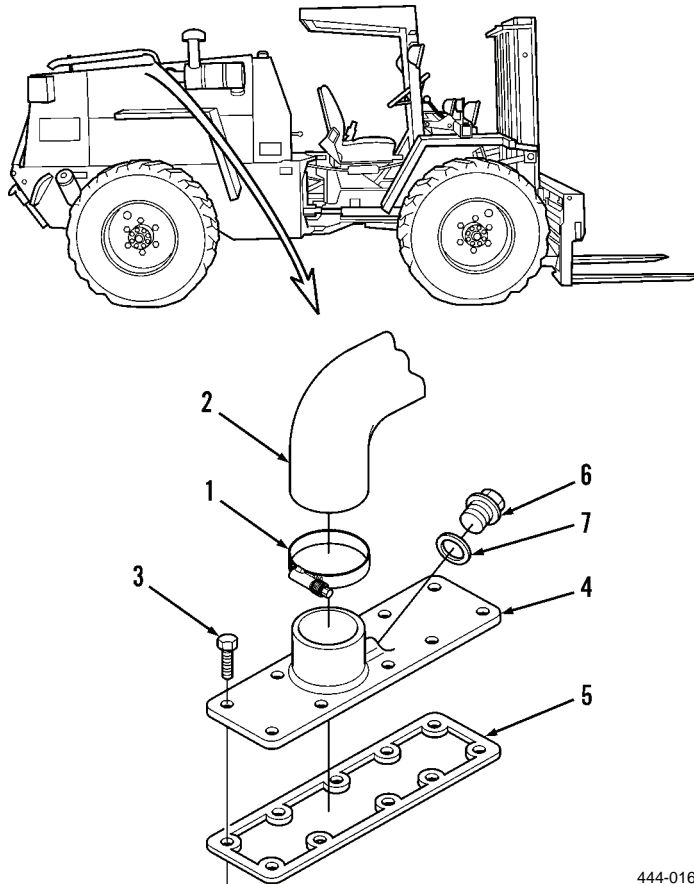

444-0169

**Figure 1. Intake Manifold.****END OF TASK**

**CLEANING****WARNING**

- Solvent cleaning compound MIL-PRF-680 Type III is an environmentally compliant and low toxic material. However, it may be irritating to the eyes and skin. Use protective gloves and goggles. Use in well-ventilated areas. Keep away from open flames and other sources of ignition. Failure to do so may result in injury or death to personnel.
  - Particles blown by compressed air are hazardous. DO NOT exceed 15 PSI (103 kPa) nozzle pressure when drying parts with compressed air. DO NOT direct compressed air against human skin. Make sure air stream is directed away from user and other personnel in the area. To prevent injury, user must wear protective goggles or face shield. Failure to follow this warning may result in injury to personnel.
1. Clean all parts using solvent cleaning compound. Dry thoroughly with compressed air.
  2. Clean intake manifold using wire brush; remove all rust, carbon, and oxidized material. Ensure all traces of gasket material are removed.

**CAUTION**

When cleaning cylinder head mating surface, ensure gasket material does not fall into cylinder head ports. Damage to engine may result from foreign material falling into ports.

3. Clean cylinder head mating surface with solvent cleaning compound. Remove all traces of gasket material.
4. Inspect intake manifold (Figure 1, Item 4). Replace if cracked or damaged.

**WARNING**

If NBC exposure is suspected, all air filter media should be handled by personnel wearing protective equipment. Consult your unit NBC Officer or NBC NCO for appropriate handling or disposal procedures.

5. Inspect air cleaner hose (Figure 1, Item 2). Replace if cracked or worn.
6. Inspect all other parts. Replace if damaged.

**END OF TASK**

**INSTALLATION/REPLACEMENT**

1. Position new sealing washer (Figure 3, Item 7) on intake manifold (Figure 3, Item 4).
2. Install plug (Figure 3, Item 6) on intake manifold (Figure 3, Item 4).
3. Position new gasket (Figure 3, Item 5) on cylinder block.
4. Position intake manifold (Figure 3, Item 4) on cylinder head.

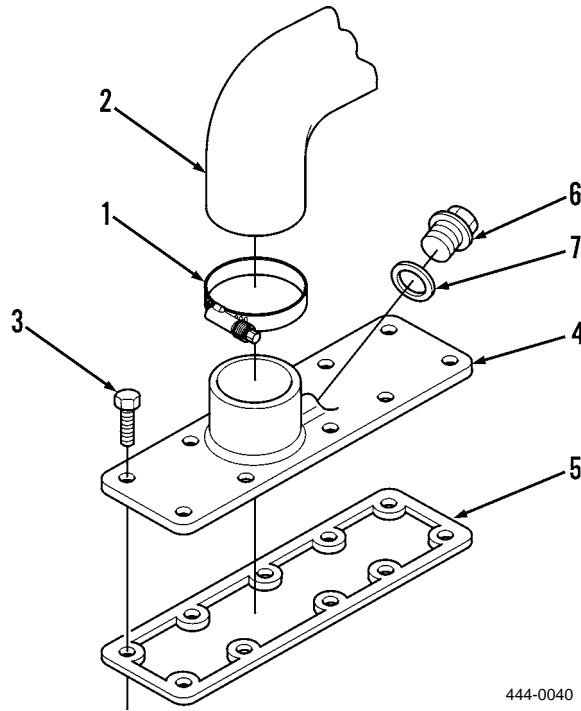

444-0040

**Figure 2. Intake Manifold Assembly.**

5. Install seven capscrews on intake manifold (Figure 2, Item 4) and tighten to 18 lb-ft (24 Nm). Tighten all 10 capscrews to 18 lb-ft (24 Nm) in pattern shown (Figure 3) when fuel injection lines and fittings are installed.

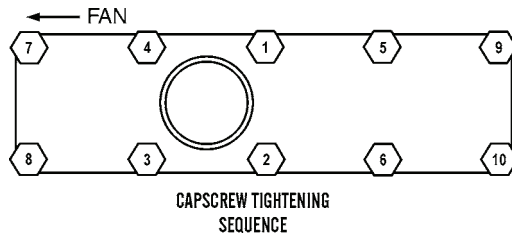

444-0041

**Figure 3. Tightening Sequence.**

6. Position hose clamp (Figure 2, Item 1) on air cleaner hose (Figure 2, Item 2).
7. Connect air cleaner hose (Figure 2, Item 2) to intake manifold (Figure 2, Item 4) and tighten hose clamp (Figure 2, Item 1).

**END OF TASK**

**END OF WORK PACKAGE**

---

## ORGANIZATIONAL MAINTENANCE INSTRUCTIONS

### EXHAUST MANIFOLD MAINTENANCE (MODEL 207)

Removal, Disassembly, Cleaning, Inspection, Assembly, Installation

---

#### INITIAL SETUP

##### Maintenance Level

Organizational

##### Tools and Special Tools

Tool kit, general mechanic's (Item 15, WP 0309)

Shop equipment, common no. 1 (Item 2, WP 0309)

##### Materials/Parts

Cleaning compound, solvent (Item 10, WP 0310)

##### Materials/Parts - Continued

Rag, wiping (Item 26, WP 0310)

Exhaust manifold gasket

Gasket (2)

##### Equipment Condition

Right side panel removed (WP 0179)

Right-rear fender removed (WP 0178)

Spark arresting muffler and exhaust pipe removed  
(WP 0076)

Left hood panel removed (WP 0182)

---

**REMOVAL**

1. Remove five nuts (Figure 1, Item 1), washers (Figure 1, Item 2), and three clamps (Figure 1, Item 3) from exhaust manifold (Figure 1, Item 4).

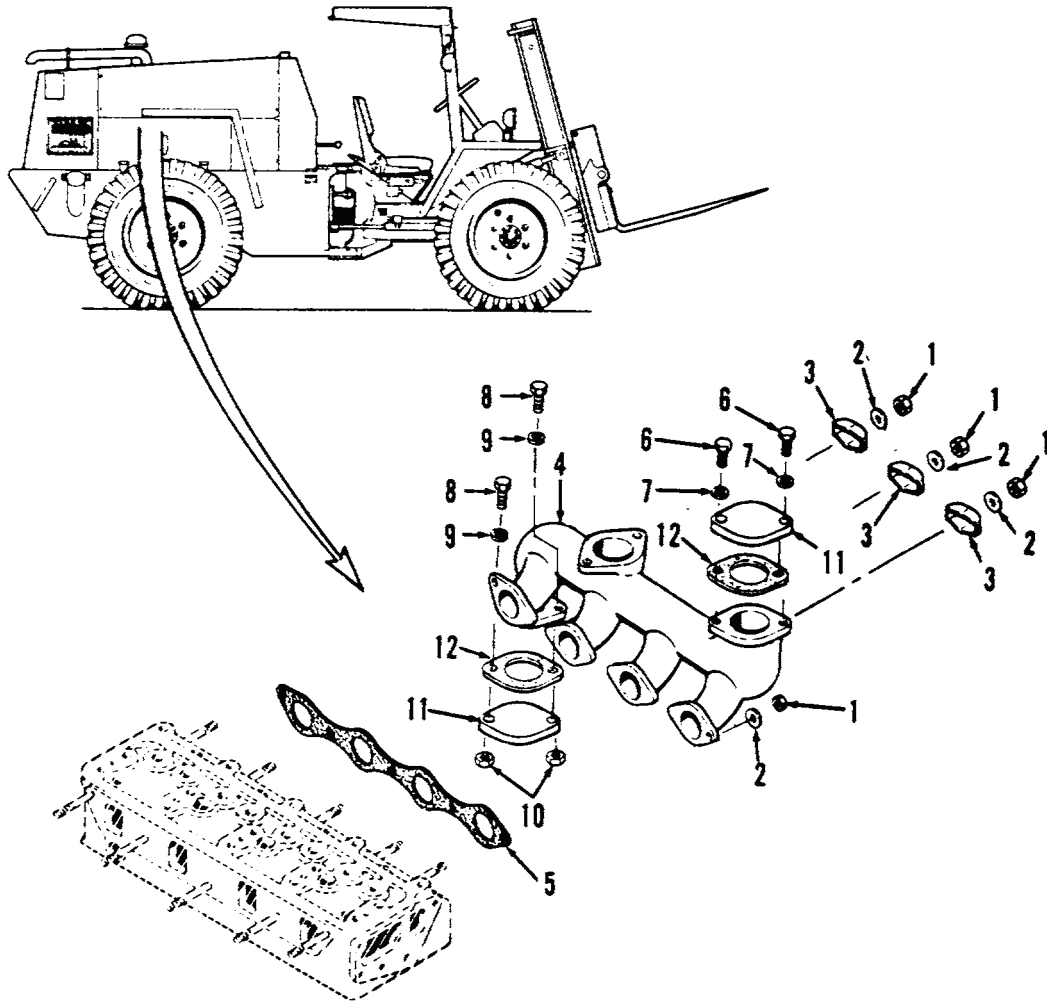

TA 126869

**Figure 1. Exhaust Manifold.**



**REMOVAL - CONTINUED**

- Pull front of exhaust manifold from front cylinder head stud (Figure 2). Swing manifold upward and remove from rear cylinder head stud.

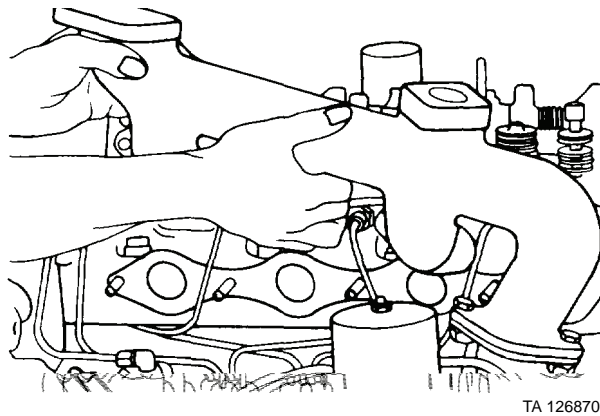

**Figure 2. Exhaust Manifold and Stud.**

- Remove and discard exhaust manifold gasket (Figure 1, Item 5).

**END OF TASK****DISASSEMBLY**

- Remove two screws (Figure 1, Item 6), washers (Figure 1, Item 7), outlet cover plate (Figure 1, Item 11), and gasket (Figure 1, Item 12) from exhaust manifold (Figure 1, Item 4). Discard gasket.
- At other end of exhaust manifold (Figure 1, Item 4), remove two screws (Figure 1, Item 8), washers (Figure 1, Item 9), nuts (Figure 1, Item 10), outlet cover plate (Figure 1, Item 11), and gasket (Figure 1, Item 12). Discard gasket.

**END OF TASK****CLEANING****WARNING**

- Solvent cleaning compound MIL-PRF-680 Type III is an environmentally compliant and low toxic material. However, it may be irritating to the eyes and skin. Use protective gloves and goggles. Use in well-ventilated areas. Keep away from open flames and other sources of ignition. Failure to do so may result in injury or death to personnel.
  - Particles blown by compressed air are hazardous. DO NOT exceed 15 PSI (103 kPa) nozzle pressure when drying parts with compressed air. DO NOT direct compressed air against human skin. Make sure air stream is directed away from user and other personnel in the area. To prevent injury, user must wear protective goggles or face shield. Failure to follow this warning may result in injury to personnel.
- Clean all parts, except exhaust manifold, with solvent cleaning compound. Dry thoroughly with compressed air.
  - Clean exhaust manifold with wire brush to remove all rust, carbon, and oxidized material. Ensure all traces of gasket material are removed.
  - Clean mating surface and studs of engine cylinder head with solvent cleaning compound.

**END OF TASK**

**INSPECTION**

1. Inspect exhaust manifold. Replace if cracked or damaged or if threads are damaged.
2. Inspect all other parts. Replace if damaged.
3. Inspect cylinder head studs. If studs are broken or have damaged threads, notify Direct Support Maintenance.

**END OF TASK****ASSEMBLY**

1. Install new gasket (Figure 3, Item 12) and outlet cover plate (Figure 3, Item 11) on exhaust manifold (Figure 3, Item 4) with two nuts (Figure 3, Item 10), washers (Figure 3, Item 9), and screws (Figure 3, Item 8).
2. At other end of exhaust manifold (Figure 3, Item 4), install new gasket (Figure 3, Item 12) and outlet cover plate (Figure 3, Item 11) with two washers (Figure 3, Item 7) and screws (Figure 3, Item 6).

**END OF TASK**

**INSTALLATION**

1. Position new exhaust manifold gasket (Figure 3, Item 5) on cylinder head.
2. Hold front of exhaust manifold (Figure 3, Item 4) in raised position and position rear of exhaust manifold on rear cylinder head stud. Lower manifold and position front of exhaust manifold on front cylinder head stud.
3. Install exhaust manifold (Figure 3, Item 4) with three clamps (Figure 3, Item 3), five washers (Figure 3, Item 2), and nuts (Figure 3, Item 1). Tighten nuts to 25-30 lb-ft (34-41 Nm).

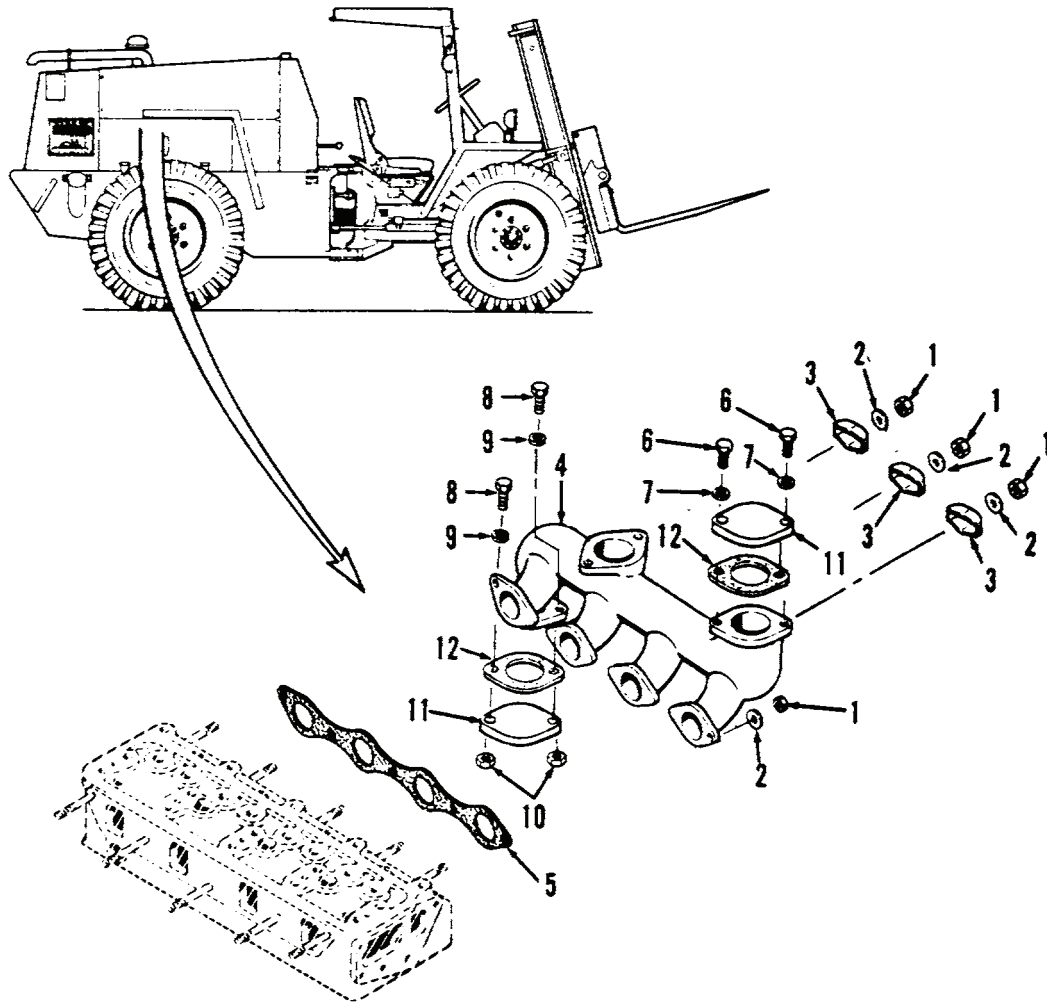

TA 126869

**Figure 3. Exhaust Manifold.****END OF TASK****END OF WORK PACKAGE**



---

## ORGANIZATIONAL MAINTENANCE INSTRUCTIONS

### EXHAUST MANIFOLD REPLACEMENT (MODEL 4-390)

Removal, Cleaning, Inspection, Installation/Replacement

---

#### INITIAL SETUP

##### Maintenance Level

Organizational

##### Tools and Special Tools

Tool kit, general mechanic's (Item 15, WP 0309)

Shop equipment, common no. 1 (Item 2, WP 0309)

##### Materials/Parts

Brush, wire (Item 8, WP 0310)

Cleaning compound, solvent (Item 10, WP 0310)

##### Materials/Parts - Continued

Rag, wiping (Item 26, WP 0310)

Exhaust manifold gasket (4)

##### Equipment Condition

Air cleaner hose disconnected from air cleaner  
(WP 0062)

Left side panel removed (WP 0179)

Left fender removed (WP 0178)

Left hood support plate removed (WP 0183)

Spark arresting muffler removed (WP 0077)

---

**REMOVAL**

1. Remove eight capscrews (Figure 1, Item 1) from exhaust manifold (Figure 1, Item 2).
2. Remove exhaust manifold (Figure 1, Item 2) from cylinder head.
3. Remove and discard four gaskets (Figure 1, Item 3).

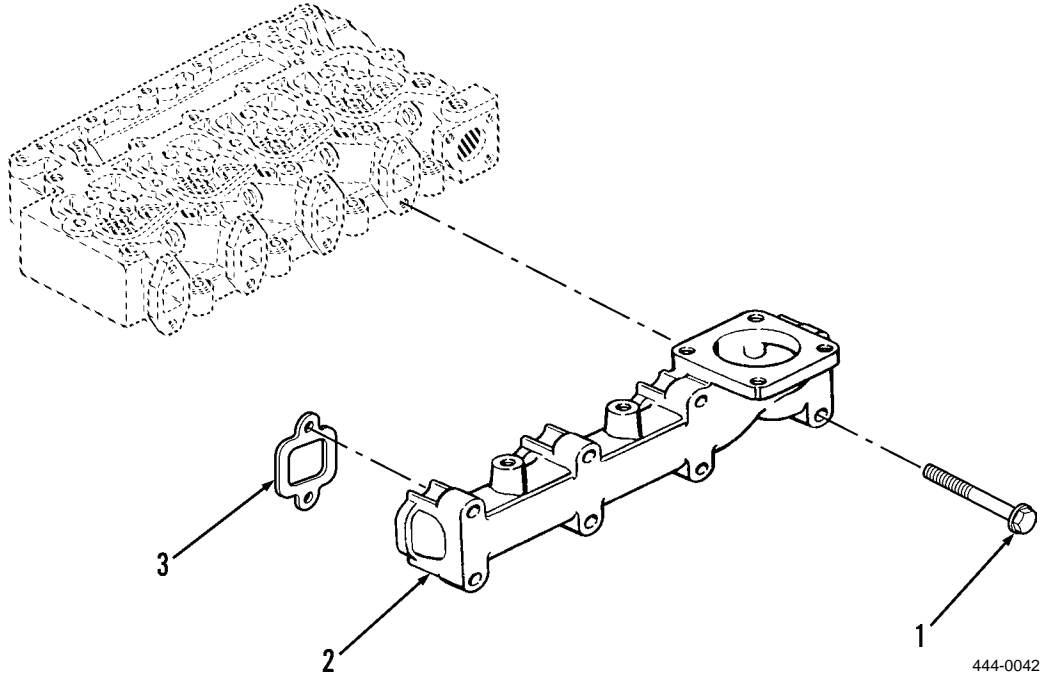

Figure 1. Exhaust Manifold.

**END OF TASK****CLEANING**

1. Use wire brush to clean exhaust manifold (Figure 2, Item 2). Remove all rust, carbon, oxidized material, and gasket material.



**WARNING**



- Solvent cleaning compound MIL-PRF-680 Type III is an environmentally compliant and low toxic material. However, it may be irritating to the eyes and skin. Use protective gloves and goggles. Use in well-ventilated areas. Keep away from open flames and other sources of ignition. Failure to do so may result in injury or death to personnel.
  - Particles blown by compressed air are hazardous. DO NOT exceed 15 PSI (103 kPa) nozzle pressure when drying parts with compressed air. DO NOT direct compressed air against human skin. Make sure air stream is directed away from user and other personnel in the area. To prevent injury, user must wear protective goggles or face shield. Failure to follow this warning may result in injury to personnel.
2. Use solvent cleaning compound to clean all parts. Dry parts thoroughly with compressed air.
  3. Clean cylinder head mating surface with solvent cleaning compound. Ensure all traces of gasket material are removed.

**END OF TASK**

**INSPECTION**

1. Inspect exhaust manifold (Figure 1, Item 2). Replace if cracked or damaged
2. Inspect all other parts. Replace if cracked or damaged.

**END OF TASK****INSTALLATION/REPLACEMENT**

1. Position four new gaskets (Figure 1, Item 3) on cylinder head.
2. Position exhaust manifold (Figure 1, Item 2) on cylinder head and install eight capscrews (Figure 1, Item 1). Tighten capscrews to 32 lb-ft (43 Nm) using tightening sequence in Figure 2.

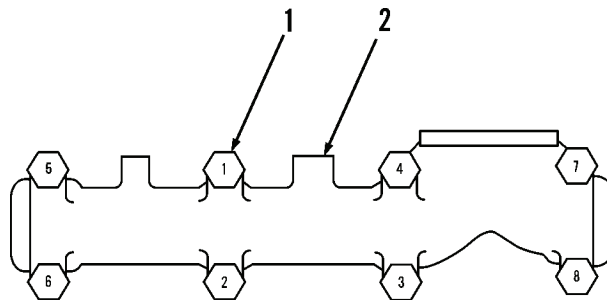

**CAPSCREW TIGHTENING  
SEQUENCE**

444-0043

**Figure 2. Tightening Sequence.**

**END OF TASK****END OF WORK PACKAGE**





# ORGANIZATIONAL MAINTENANCE INSTRUCTIONS

## FUEL INJECTION PUMP TESTING (MODEL 207)

### Testing

#### INITIAL SETUP

##### Maintenance Level

Organizational

##### Tools and Special Tools

Tool kit, general mechanic's (Item 15, WP 0309)

##### Materials/Parts

Rag, wiping (Item 26, WP 0310)

##### Personnel Required

Two

##### References

TM 10-3930-638-10

##### Equipment Condition

Vehicle parked on level surface

Engine OFF

Transmission direction selector in N (Neutral) position

Parking brake applied

Right side panel removed (WP 0179)

#### TESTING

1. At top of engine, loosen four fuel injector nozzle fittings (Figure 1).

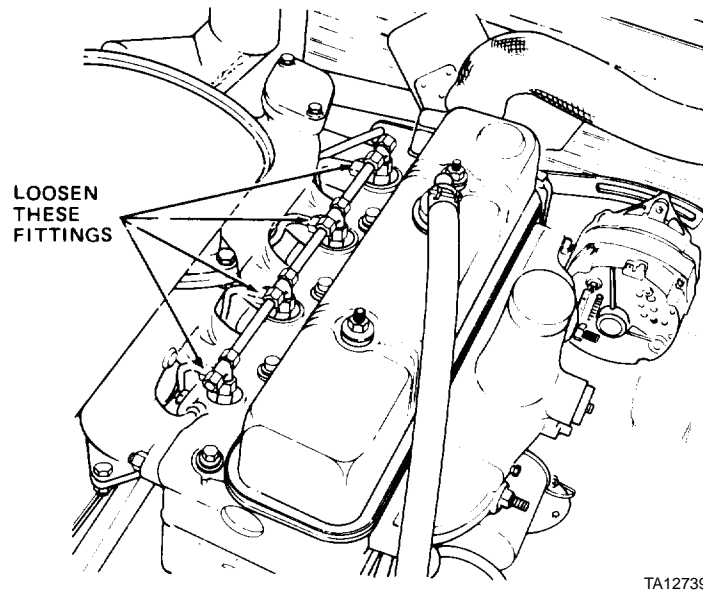

Figure 1. Top of Engine.

2. Place ignition switch in ON position (TM 10-3930-638-10).

---

**TESTING - CONTINUED****WARNING**

DO NOT perform fuel system checks while smoking or near fire, flames, or sparks. Fuel may ignite, causing damage to machine and injury or death to personnel.

3. Press start switch. As engine is cranking, ensure fuel flows out of loosened fuel injector nozzle fittings.
4. Release start switch and place ignition switch in OFF position (TM 10-3930-638-10).
5. At top of engine, tighten four fuel injector nozzle fittings.

**END OF TASK****END OF WORK PACKAGE**

# ORGANIZATIONAL MAINTENANCE INSTRUCTIONS

## FUEL INJECTION PUMP TESTING (MODEL 4-390)

### Testing

#### INITIAL SETUP

##### Maintenance Level

Organizational

##### Tools and Special Tools

Tool kit, general mechanic's (Item 15, WP 0309)

Shop equipment, common no. 1 (Item 2, WP 0309)

##### Materials/Parts

Rag, wiping (Item 26, WP 0310)

##### Personnel Required

Two

##### References

TM 10-3930-638-10

##### Equipment Condition

Vehicle parked on level surface

Engine OFF

Transmission direction selector in N (Neutral) position

Parking brake applied

Top hood removed (WP 0181)

#### TESTING

1. In engine compartment, loosen four fuel injector nozzle fittings at top of engine (Figure 1).
2. In operator's compartment, place ignition switch in ON position (TM 10-3930-638-10).

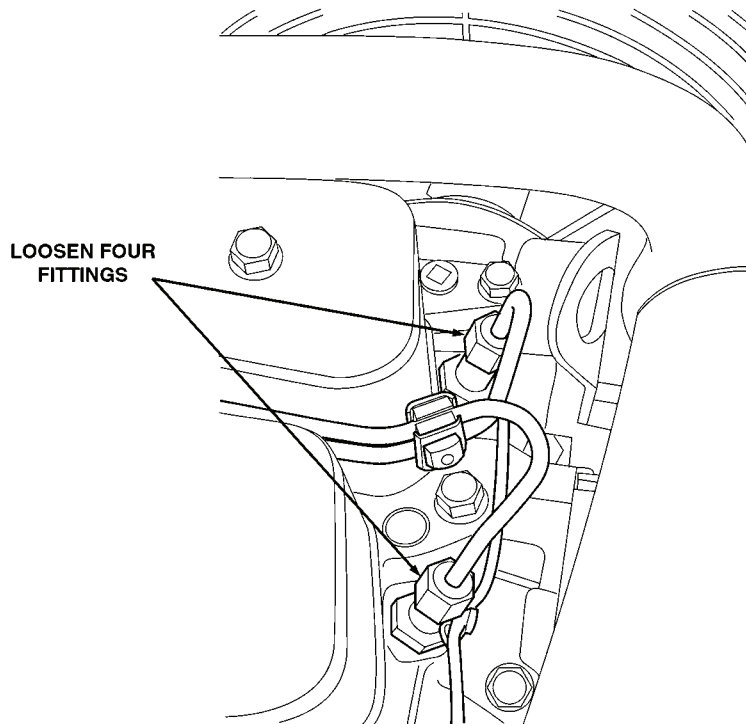

444-0044

Figure 1. Fuel Injector Fittings.

**TESTING - CONTINUED**

3. Depress start switch. While engine is cranking, ensure fuel is pumped out of all four fuel injection nozzle fittings loosened in step 1.
4. Place ignition switch in OFF position (TM 10-3930-638-10).
5. In engine compartment, tighten four fuel injector nozzle fittings.

**END OF TASK****END OF WORK PACKAGE**

---

## ORGANIZATIONAL MAINTENANCE INSTRUCTIONS

### ELECTRIC FUEL PUMP AND LINES MAINTENANCE (MODEL 207)

#### Removal, Cleaning, Inspection, Installation, Testing

---

#### INITIAL SETUP

**Maintenance Level**

Organizational

**Tools and Special Tools**

Tool kit, general mechanic's (Item 15, WP 0309)

Container, 1-gal. capacity

Fuel pressure gage

Tee

**Materials/Parts**

Cleaning compound, solvent (Item 10, WP 0310)

Diesel fuel, arctic (Item 14, WP 0310)

**Materials/Parts - Continued**

Diesel fuel, DF-2 (Item 15, WP 0310)

Rag, wiping (Item 26, WP 0310)

Lockwasher (2)

**Personnel Required**

Two

**References**

TM 10-3930-638-10

**Equipment Condition**

Engine OFF

Right side panel removed (WP 0179)

---

**REMOVAL****WARNING**

DO NOT smoke or permit any open flame in area of machine while you are servicing fuel system. Failure to follow this warning may result in injury or death to personnel, or damage to equipment.

**NOTE**

Perform step 1 for vehicle with serial number 9150018 and below.

1. At right rear of engine compartment, loosen screw terminal (Figure 1, Item 5) and disconnect lead of rear wiring harness from electric fuel pump (Figure 1, Item 12).

**NOTE**

Perform step 2 for vehicle with serial number 9150019 and above.

2. At right rear of engine compartment, disconnect wire lead (Figure 1, Item 5A) from lead of rear wiring harness.
3. Loosen two hose clamps (Figure 1, Item 1) and remove filter supply hose (Figure 1, Item 2) from between electric fuel pump (Figure 1, Item 12) and fuel filter head.
4. Loosen two hose clamps (Figure 1, Item 3) and remove fuel filter hose (Figure 1, Item 4) from between electric fuel pump (Figure 1, Item 12) and in-line fuel filter.
5. Remove two hose barbs (Figure 1, Items 6 and 7) from electric fuel pump (Figure 1, Item 12).
6. Remove two nuts (Figure 1, Item 8), lockwashers (Figure 1, Item 9), washers (Figure 1, Item 10), capscrews (Figure 1, Item 11), and electric fuel pump (Figure 1, Item 12) from vehicle. Discard lockwashers.

**END OF TASK****CLEANING****WARNING**

DO NOT clean using fuel while smoking or near fire, flames, or sparks. Fuel may ignite, causing damage to machine and injury or death to personnel.

1. Clean filter supply hose (Figure 1, Item 2) and fuel filter hose (Figure 1, Item 4) with clean diesel fuel. Dry with clean rags.

**WARNING**

Solvent cleaning compound MIL-PRF-690 Type III is an environmentally complaint and low toxic material. However, it may be irritating to the eyes and skin. Use protective gloves and goggles. Use in well-ventilated areas. Keep away from open flames and other sources of ignition. Failure to do so may result in injury or death to personnel.

2. Clean all other parts with solvent cleaning compound. Dry with clean rags.

**END OF TASK**

**INSPECTION - CONTINUED**

1. Inspect hose clamps (Figure 1, Items 1 and 3). Replace if damaged.
2. Inspect filter supply hose (Figure 1, Item 2) and fuel filter hose (Figure 1, Item 4). Replace if cracked or split.
3. Inspect hose barbs (Figure 1, Items 6 and 7). Replace if cracked or threads are damaged.
4. Inspect all other parts. Replace if damaged.

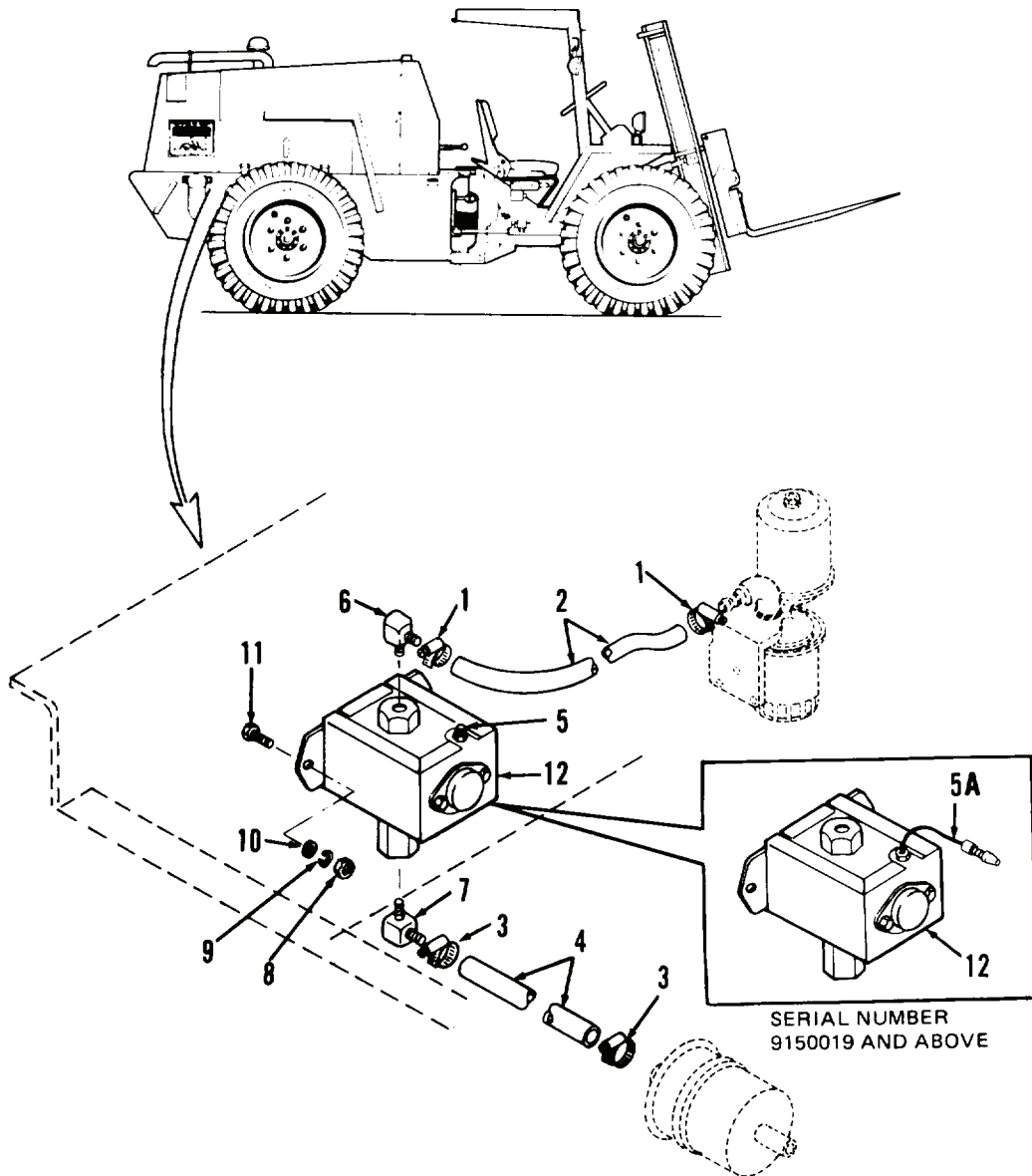

TA301519

**Figure 1. Electric Fuel Pump.****END OF TASK**

**INSTALLATION**

1. Install electric fuel pump (Figure 2, Item 12) on vehicle with two capscrews (Figure 2, Item 11), washers (Figure 2, Item 10), new lockwashers (Figure 2, Item 9), and nuts (Figure 2, Item 8).
2. Install two hose barbs (Figure 2, Items 7 and 6) on electric fuel pump (Figure 2, Item 12).
3. Install fuel filter hose (Figure 2, Item 4) between in-line fuel filter and electric fuel pump (Figure 2, Item 12). Tighten two hose clamps (Figure 2, Item 3).
4. Install filter supply hose (Figure 2, Item 2) between fuel filter head and electric fuel pump (Figure 2, Item 12). Tighten two hose clamps (Figure 2, Item 1).

**NOTE**

Perform step 5 for vehicle with serial number 9150019 and above.

5. Connect wire lead (Figure 2, Item 5A) of electric fuel pump (Figure 2, Item 12) to lead of rear wiring harness.

**NOTE**

Perform step 6 for vehicle with serial number 9150018 and below.

6. Connect lead of rear wiring harness to electric fuel pump (Figure 2, Item 12) and tighten screw terminal (Figure 2, Item 5).

**END OF TASK****TESTING**

1. Loosen hose clamp (Figure 2, Item 1) on fuel supply hose (Figure 2, Item 2) at fuel filter head.
2. Disconnect fuel supply hose (Figure 2, Item 2) from fuel filter head and place end of fuel supply hose into a 1-gal. (3.8-L) container.
3. Place ignition switch in ON position (TM 10-3930-638-10).

**NOTE**

If fuel does not pump out of fuel supply hose, replace electric fuel pump.

4. Listen for buzzing sound from electric fuel pump (Figure 2, Item 12) and verify that fuel is being pumped out of fuel supply hose (Figure 2, Item 2) into container. Place ignition switch in OFF position (TM 10-3930-638-10).
5. Install tee between fuel supply hose (Figure 2, Item 2) and fuel filter head. Tighten hose clamp (Figure 2, Item 1).
6. Install a fuel pressure gage on tee.
7. Place ignition switch in ON position (TM 10-3930-638-10).

**NOTE**

If pressure of fuel is not as specified, replace electric fuel pump.

8. Observe fuel pressure gage. Gage should indicate 4.5 to 6 PSI (31 to 41 kPa).
9. Remove fuel pressure gage and tee.
10. Connect fuel supply hose (Figure 2, Item 2) to fuel filter head. Tighten hose clamp (Figure 2, Item 1).



TESTING - CONTINUED

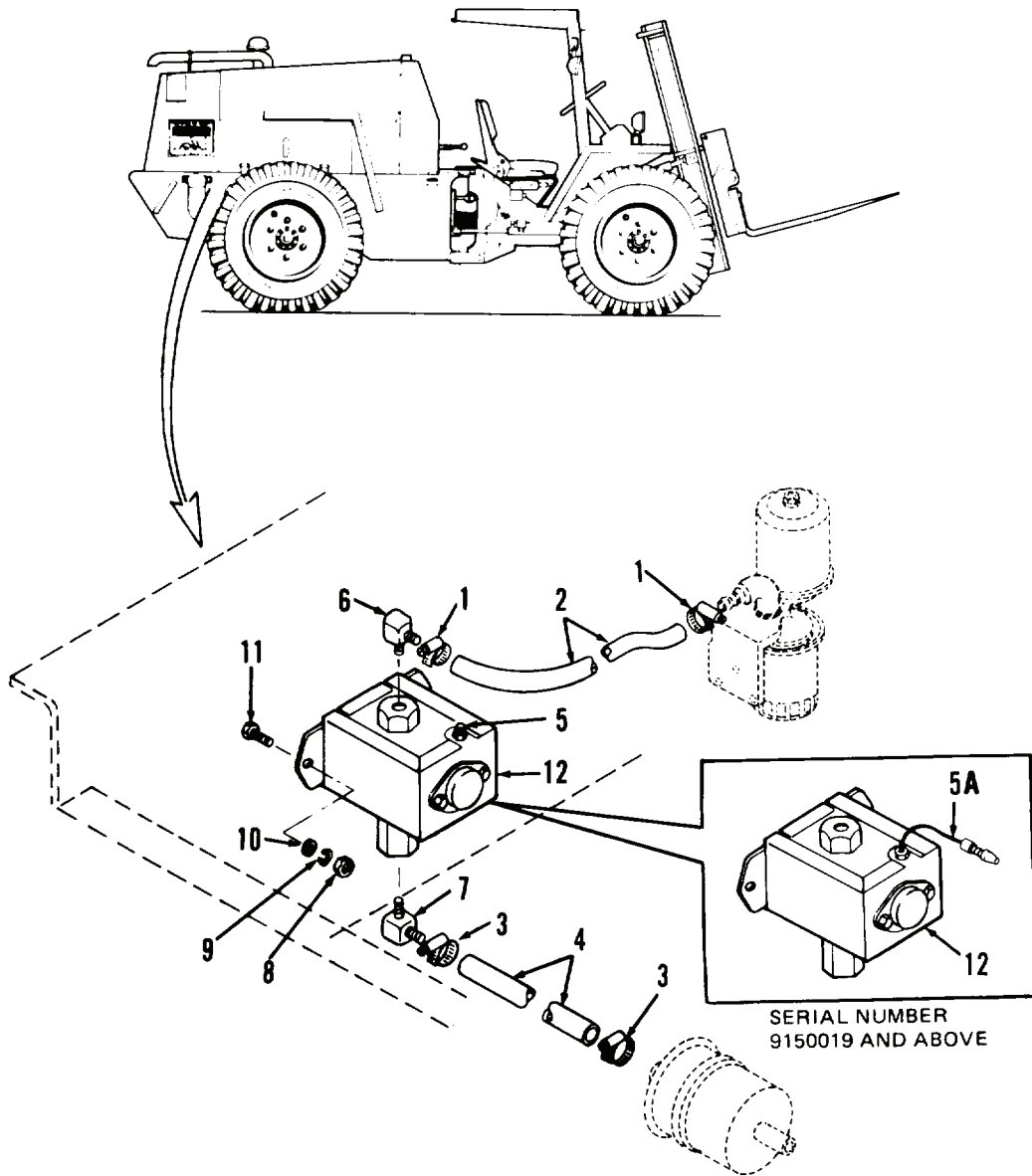

TA301519

Figure 2. Electric Fuel Pump.

END OF TASK

END OF WORK PACKAGE



---

## ORGANIZATIONAL MAINTENANCE INSTRUCTIONS

### FUEL PUMP AND LINES MAINTENANCE (MODEL 4-390)

Removal, Cleaning, Inspection, Installation, Testing

---

#### INITIAL SETUP

##### Maintenance Level

Organizational

##### Tools and Special Tools

Tool kit, general mechanic's (Item 15, WP 0309)

Shop equipment, common no. 1 (Item 2, WP 0309)

##### Materials/Parts

Cleaning compound, solvent (Item 10, WP 0310)

Diesel fuel, arctic (Item 14, WP 0310)

Diesel fuel, DF-2 (Item 15, WP 0310)

##### Materials/Parts - Continued

Rag, wiping (Item 26, WP 0310)

Gasket (2)

##### Personnel Required

Two

##### References

TM 10-3930-638-10

##### Equipment Condition

Engine OFF

Right side panel removed (WP 0179)

In-line fuel filter removed (WP 0068)

---

**REMOVAL**

1. At right rear of engine compartment, loosen hose clamp (Figure 1, Item 1) and remove fuel hose (Figure 1, Item 2) from hose barb (Figure 1, Item 3).
2. Remove hose clamp (Figure 1, Item 1) from fuel hose (Figure 1, Item 2).
3. Remove hose barb (Figure 1, Item 3) and elbow (Figure 1, Item 4) from top of fuel tank.
4. At right side of engine, remove bolt (Figure 1, Item 5) and clamp (Figure 1, Item 6) from fuel hose (Figure 1, Item 7).

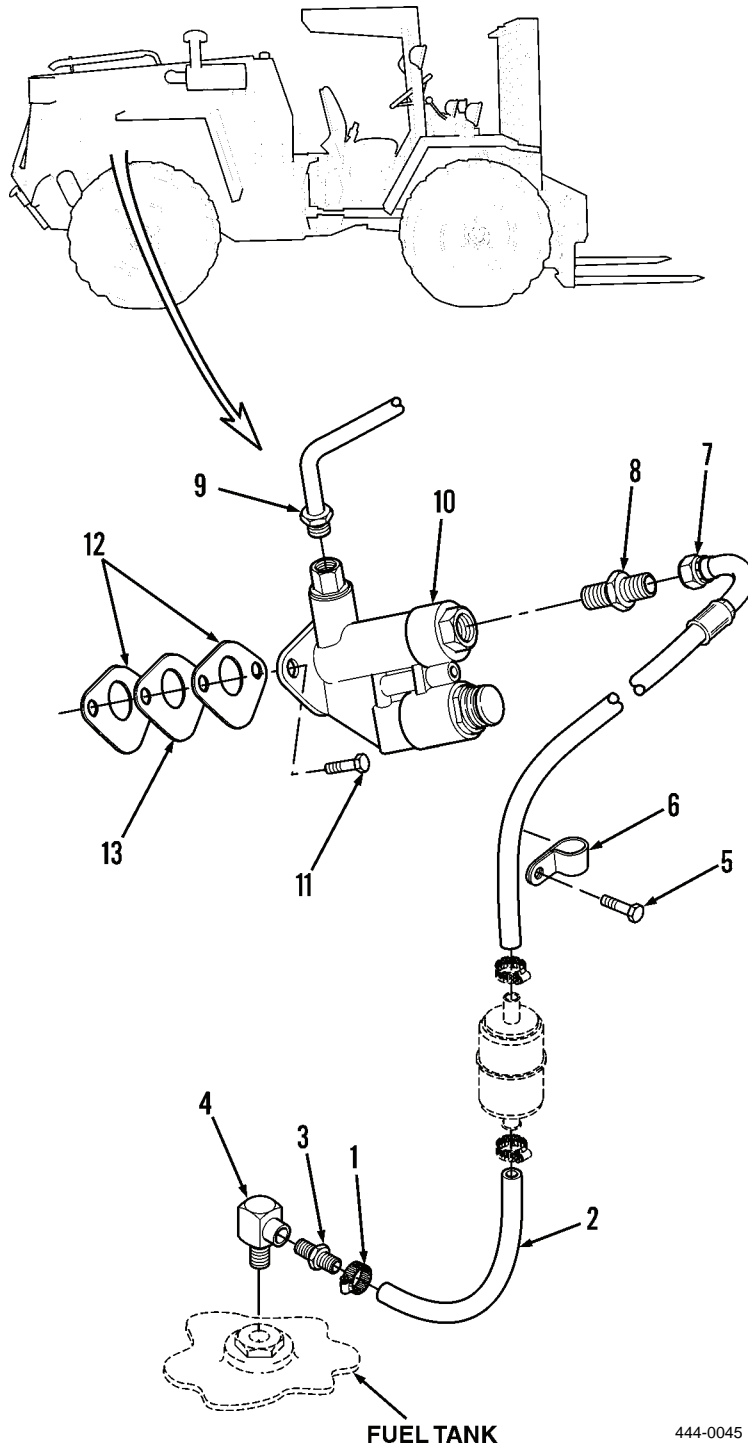

444-0045

**Figure 1. Fuel Pump and Lines.**

**REMOVAL - CONTINUED**

5. At fuel pump (Figure 1, Item 10), remove fuel hose (Figure 1, Item 7) from fuel pump fitting (Figure 1, Item 8).
6. Remove fuel pump fitting (Figure 1, Item 8) from fuel pump (Figure 1, Item 10) adapter.
7. Disconnect fuel tube (Figure 1, Item 9) from top of fuel pump (Figure 1, Item 10).
8. Remove two bolts (Figure 1, Item 11), fuel pump (Figure 1, Item 10), two gaskets (Figure 1, Item 12) and spacer (Figure 1, Item 13) from side of engine. Discard gaskets.

**END OF TASK****CLEANING**

1. Clean fuel hose (Figure 1, Items 2 and 7) inside and outside with clean diesel fuel.

**WARNING**

- Solvent cleaning compound MIL-PRF-680 Type III is an environmentally compliant and low toxic material. However, it may be irritating to the eyes and skin. Use protective gloves and goggles. Use in well-ventilated areas. Keep away from open flames and other sources of ignition. Failure to do so may result in injury or death to personnel.
  - Particles blown by compressed air are hazardous. **DO NOT** exceed 15 PSI (103 kPa) nozzle pressure when drying parts with compressed air. **DO NOT** direct compressed air against human skin. Failure to follow this warning may result in injury to personnel. Make sure air stream is directed away from user and other personnel in the area. To prevent injury, user must wear protective goggles or face shield.
2. Clean all other parts with solvent cleaning compound. Dry thoroughly with compressed air.

**END OF TASK****INSPECTION**

1. Inspect fuel hoses (Figure 1, Items 2 and 7). Replace if cracked or split.
2. Inspect all other parts. Replace if damaged.

**END OF TASK****INSTALLATION**

1. At right side of engine, install spacer (Figure 1, Item 13), two new gaskets (Figure 1, Item 12), and fuel pump (Figure 1, Item 10) with two bolts (Figure 1, Item 11). Tighten bolts to 15 to 20 lb-ft (20 to 27 Nm).
2. Connect fuel tube (Figure 1, Item 9) to top of fuel pump (Figure 1, Item 10). Tighten nut of fuel tube to 10 to 20 lb-ft (14 to 27 Nm).
3. Install fuel pump fitting (Figure 1, Item 8) on fuel pump (Figure 1, Item 10) adapter.
4. Connect fuel hose (Figure 1, Item 7) to fuel pump fitting (Figure 1, Item 8). Tighten nut of fuel hose to 10 to 20 lb-ft (14 to 27 Nm).

**INSTALLATION - CONTINUED**

5. Install clamp (Figure 2, Item 6) on right side of engine with bolt (Figure 2, Item 5).
6. Install elbow (Figure 2, Item 4) and hose barb (Figure 2, Item 3) on top of fuel tank.
7. Position hose clamp (Figure 2, Item 1) on fuel hose (Figure 2, Item 2).
8. Connect fuel hose (Figure 2, Item 2) to hose barb (Figure 2, Item 3) and tighten hose clamp (Figure 2, Item 1).

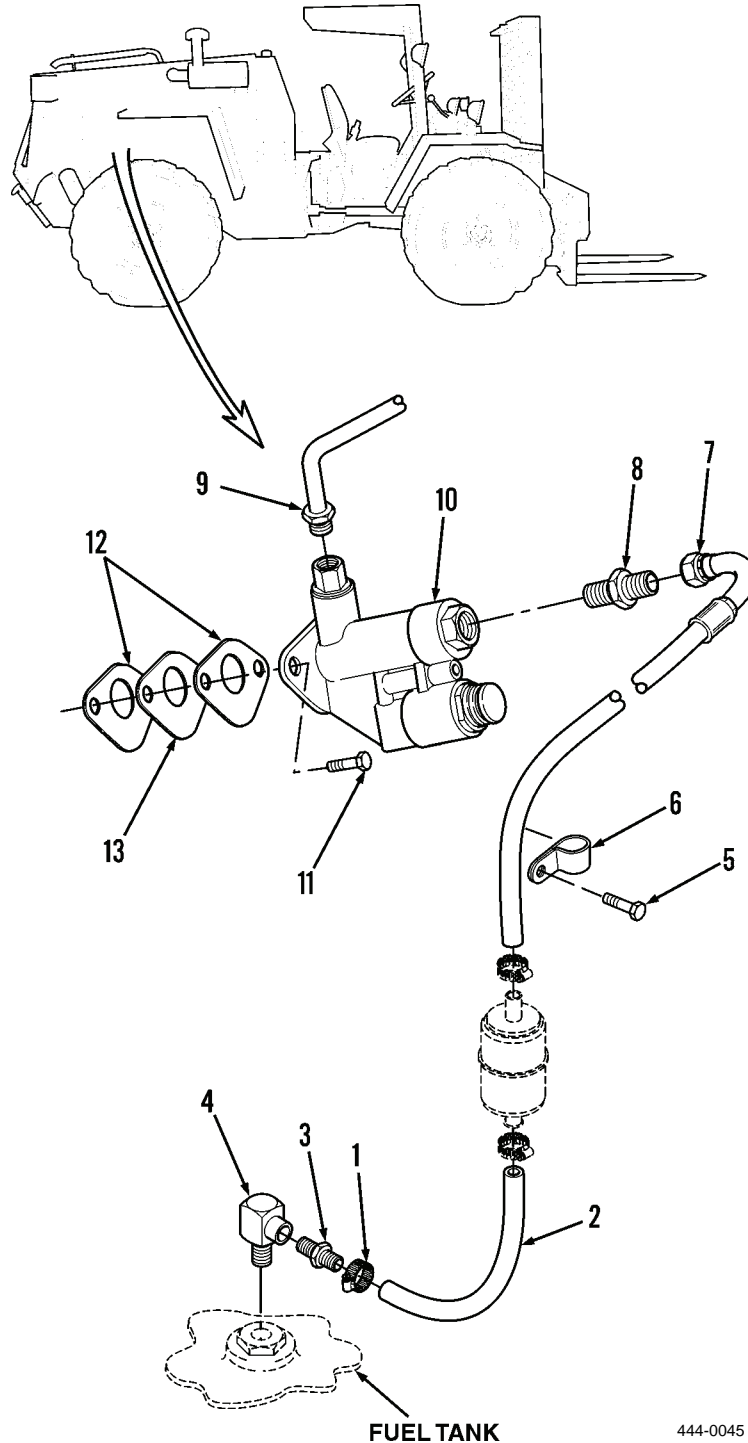

444-0045

**Figure 2. Fuel Pump and Lines.****END OF TASK**

**TESTING**

1. At right side of engine compartment, loosen connecting bolt (Figure 3, Item 14) on fuel injection pump.
2. In operator's compartment, place ignition switch in ON position (TM 10-3930-638-10).
3. Press start switch. While engine is cranking, ensure fuel is pumped out of fuel line at connecting bolt (Figure 3, Item 14).
4. If fuel is NOT pumped out of fuel line at connecting bolt (Figure 3, Item 14), replace fuel pump.
5. Tighten connecting bolt (Figure 3, Item 14).

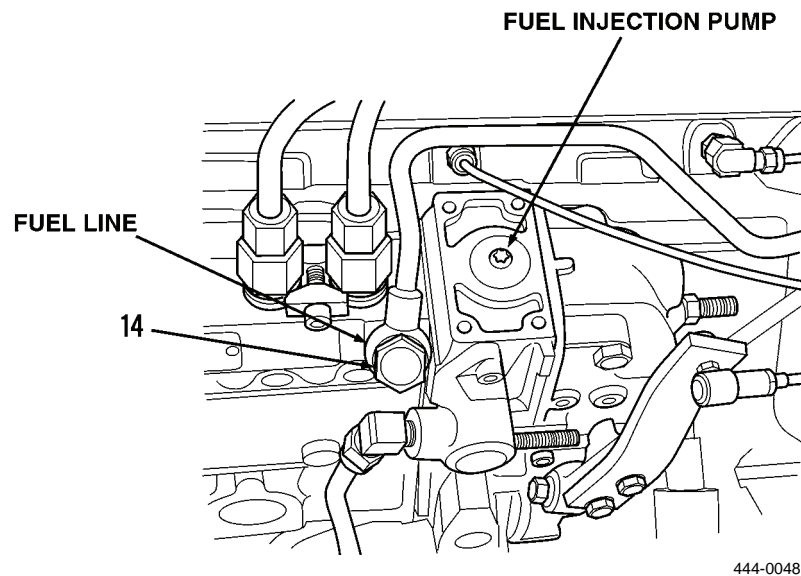

444-0048

**Figure 3. Fuel Line.****END OF TASK****END OF WORK PACKAGE**





# ORGANIZATIONAL MAINTENANCE INSTRUCTIONS

## AIR CLEANER MAINTENANCE (MODEL 207)

Removal, Disassembly, Cleaning, Inspection, Assembly, Installation

### INITIAL SETUP

#### Maintenance Level

Organizational

#### Personnel Required

Two

#### Tools and Special Tools

Tool kit, general mechanic's (Item 15, WP 0309)  
Shop equipment, common no. 1 (Item 2, WP 0309)

#### References

FM 3-3  
FM 3-3-1  
FM 3-5

#### Materials/Parts

Cleaning compound, solvent (Item 10, WP 0310)  
Rag, wiping (Item 26, WP 0310)  
Lockwasher (4)

#### Equipment Condition

Engine OFF  
Left side panel removed (WP 0179)  
Front cover panel removed (WP 0184)

### REMOVAL



WARNING



- If NBC exposure is suspected, personnel wearing protective equipment must handle all air cleaner media. Consult your NBC Officer or NBC NCO for appropriate handling or disposal procedures.
- Refer to FM 3-3, *Chemical and Biological Contamination Avoidance*, FM 3-5, *NBC Decontamination*, and FM 3-3-1, *Nuclear Contamination Avoidance*.
- NBC contaminated filters must be handled using adequate precautions and must be disposed of by trained personnel.
- Failure to follow these warnings may cause injury or death to personnel.

**REMOVAL - CONTINUED**

1. Loosen two hose clamps (Figure 1, Item 1) and remove hose (Figure 1, Item 2) from between intake manifold and air cleaner body (Figure 1, Item 25).
2. Remove four nuts (Figure 1, Item 3), lockwashers (Figure 1, Item 8), capscrews (Figure 1, Item 7), and air cleaner assembly (Figure 1, Item 6) from left hood panel. Discard lockwashers.
3. Remove two screws (Figure 1, Item 5) and two mounting clamps (Figure 1, Item 4) from body (Figure 1, Item 25) of air cleaner assembly (Figure 1, Item 6).

**NOTE**

Perform the following steps to remove air restriction indicator and fittings from vehicle.

4. Loosen nuts of two elbows (Figure 1, Item 9) and remove tube (Figure 1, Item 10) from elbows.
5. Remove elbow (Figure 1, Item 9) from pipe nipple (Figure 1, Item 12).
6. Remove other elbow (Figure 1, Item 9) from filtered fitting (Figure 1, Item 11) at intake manifold.
7. Remove filtered fitting (Figure 1, Item 11) from intake manifold.
8. Loosen nut (Figure 1, Item 13) and remove pipe nipple (Figure 1, Item 12), elbow (Figure 1, Item 15), and indicator (Figure 1, Item 14) from vehicle.

**END OF TASK****DISASSEMBLY**

1. Remove clamp (Figure 1, Item 16) and dust cap (Figure 1, Item 17) from body (Figure 1, Item 25).
2. Remove evacuator (Figure 1, Item 19) and baffle (Figure 1, Item 18) from dust cap (Figure 1, Item 17).
3. Remove wing nut (Figure 1, Item 20) and filter element (Figure 1, Item 21) from body (Figure 1, Item 25).
4. Remove clamp assembly (Figure 1, Item 23), cap (Figure 1, Item 22), and tube (Figure 1, Item 24) from body (Figure 1, Item 25).

**END OF TASK****CLEANING****WARNING**

- Solvent cleaning compound MIL-PRF-680 Type III is an environmentally compliant and low toxic material. However, it may be irritating to the eyes and skin. Use protective gloves and goggles. Use in well-ventilated areas. Keep away from open flames and other sources of ignition. Failure to do so may result in injury or death to personnel.
  - Particles blown by compressed air are hazardous. DO NOT exceed 15 PSI (103 kPa) nozzle pressure when drying parts with compressed air. Use a maximum of 30 PSI (207 kPa) when cleaning components. DO NOT direct compressed air against human skin. Make sure air stream is directed away from user and other personnel in the area. To prevent injury, user must wear protective goggles or face shield. Failure to follow this warning may result in injury to personnel.
1. Clean filter element by directing stream of compressed air at inside of filter element.
  2. Clean baffle and evacuator by rinsing with water. Dry with compressed air.
  3. Clean all other parts with solvent cleaning compound. Dry with compressed air.

**END OF TASK**

**INSPECTION**

1. Inspect filter element by placing a light inside filter element and checking condition of element. Replace if element is clogged, torn, has holes, or if gasket on end of element is damaged.
2. Inspect all other parts. Replace if cracked, dented, distorted, or clogged.

**END OF TASK****ASSEMBLY**

1. Install tube (Figure 1, Item 24), cap (Figure 1, Item 22), and clamp assembly (Figure 1, Item 23) on body (Figure 1, Item 25).
2. Install filter element (Figure 1, Item 21) and wing nut (Figure 1, Item 20) on body (Figure 1, Item 25).
3. Install baffle (Figure 1, Item 18) and evacuator (Figure 1, Item 19) on dust cap (Figure 1, Item 17).
4. Install dust cap (Figure 1, Item 17) on body (Figure 1, Item 25) with clamp (Figure 1, Item 16).

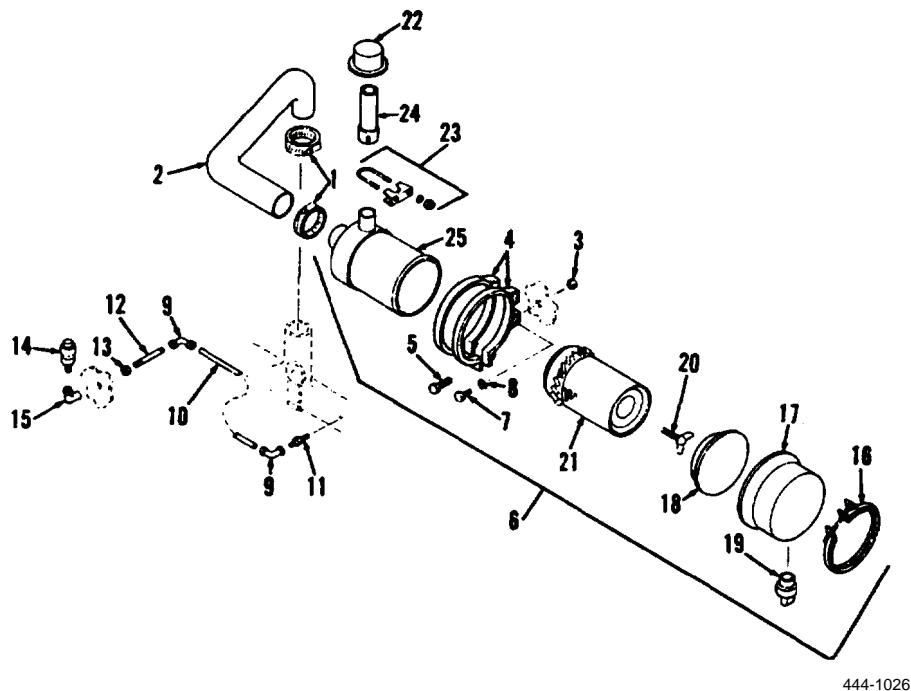

Figure 1. Air Cleaner.

**END OF TASK**

**INSTALLATION****WARNING**

- If NBC exposure is suspected, personnel wearing protective equipment must handle all air cleaner media. Consult your NBC Officer or NBC NCO for appropriate handling or disposal procedures.
- Refer to FM 3-3, *Chemical and Biological Contamination Avoidance*, FM 3-5, *NBC Decontamination*, and FM 3-3-1, *Nuclear Contamination Avoidance*.
- NBC contaminated filters must be handled using adequate precautions and must be disposed of by trained personnel.
- Failure to follow these warnings may cause injury or death to personnel.

**NOTE**

Perform steps 1 through 5 to install air restriction indicator and fittings on vehicle.

1. Position indicator (Figure 2, Item 14) and elbow (Figure 2, Item 15) on vehicle and install pipe nipple (Figure 2, Item 12). Tighten nut (Figure 2, Item 13).
2. Install filtered fitting (Figure 2, Item 11) on intake manifold.
3. Install elbow (Figure 2, Item 9) to filtered fitting (Figure 2, Item 11).
4. Install other elbow (Figure 2, Item 9) on pipe nipple (Figure 2, Item 12).
5. Install tube (Figure 2, Item 10) between two elbows (Figure 2, Item 9) and tighten nuts of elbows.
6. Loosely install two mounting clamps (Figure 2, Item 4) and two screws (Figure 2, Item 5) on body (Figure 2, Item 25) of air cleaner assembly (Figure 2, Item 6).
7. Install air cleaner assembly (Figure 2, Item 6) on left hood panel with four capscrews (Figure 2, Item 7), new lockwashers (Figure 2, Item 8), and four nuts (Figure 2, Item 3). Tighten two screws (Figure 2, Item 5).
8. Install hose (Figure 2, Item 2) between air cleaner body (Figure 2, Item 25) and intake manifold. Tighten two hose clamps (Figure 2, Item 1).

INSTALLATION - CONTINUED

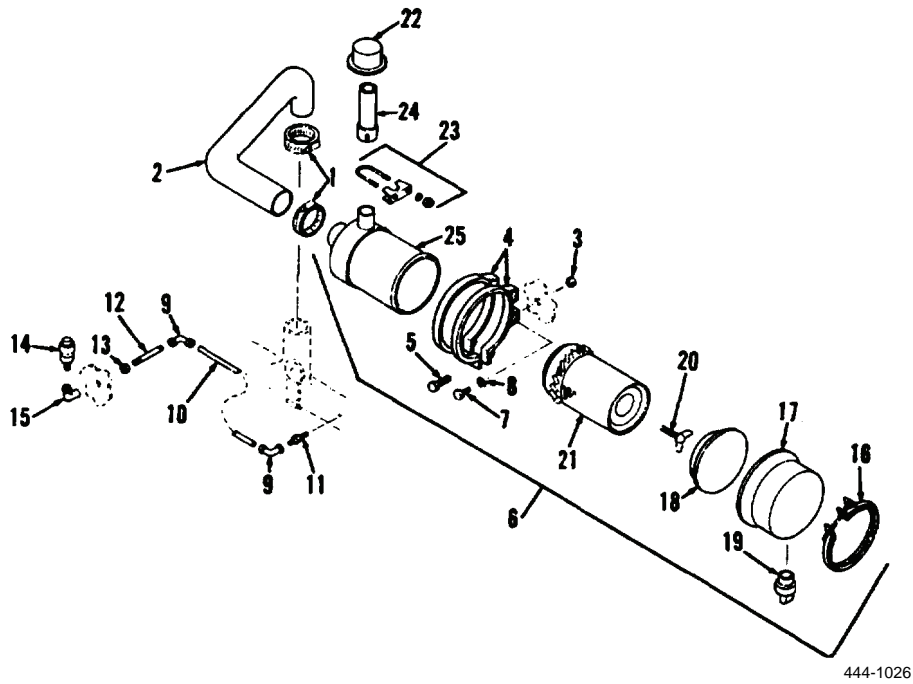

Figure 2. Air Cleaner.

END OF TASK

END OF WORK PACKAGE



---

## ORGANIZATIONAL MAINTENANCE INSTRUCTIONS

### AIR CLEANER MAINTENANCE (MODEL 4-390)

Removal, Disassembly, Cleaning, Inspection, Assembly, Installation

---

#### INITIAL SETUP

##### Maintenance Level

Organizational

##### Tools and Special Tools

Tool kit, general mechanic's (Item 15, WP 0309)

Shop equipment, common no. 1 (Item 2, WP 0309)

##### Materials/Parts

Cleaning compound, solvent (Item 10, WP 0310)

Rag, wiping (Item 26, WP 0310)

##### Materials/Parts - Continued

Strap, tiedown (Item 32, WP 0310)

Lockwasher (4)

Warm water

##### Equipment Condition

Engine OFF

Right side panel removed (WP 0179)

Top hood removed (WP 0181)

Front cover panel removed (WP 0184)

---

## REMOVAL



If NBC exposure is suspected, all air filter media should be handled by personnel wearing protective equipment. Consult your unit NBC Officer or NBC NCO for appropriate handling or disposal procedures. Failure to do so may result in injury or death to personnel.

1. At air cleaner assembly (Figure 1, Item 6) and engine intake manifold, loosen two hose clamps (Figure 1, Item 1).
2. Remove hose (Figure 1, Item 2) from air cleaner assembly and engine intake manifold.
3. Remove two hose clamps (Figure 1, Item 1) from hose (Figure 1, Item 2).
4. Behind right hood panel, remove four nuts (Figure 1, Item 3) and lockwashers (Figure 1, Item 4). Discard lockwashers.
5. Remove air cleaner assembly (Figure 1, Item 6) with two mounting clamps (Figure 1, Item 5) from vehicle.
6. Remove four screws (Figure 1, Item 7) from two mounting clamps (Figure 1, Item 5).
7. Remove two nuts (Figure 1, Item 8), screws (Figure 1, Item 9), and mounting clamps (Figure 1, Item 5) from air cleaner assembly (Figure 1, Item 6).

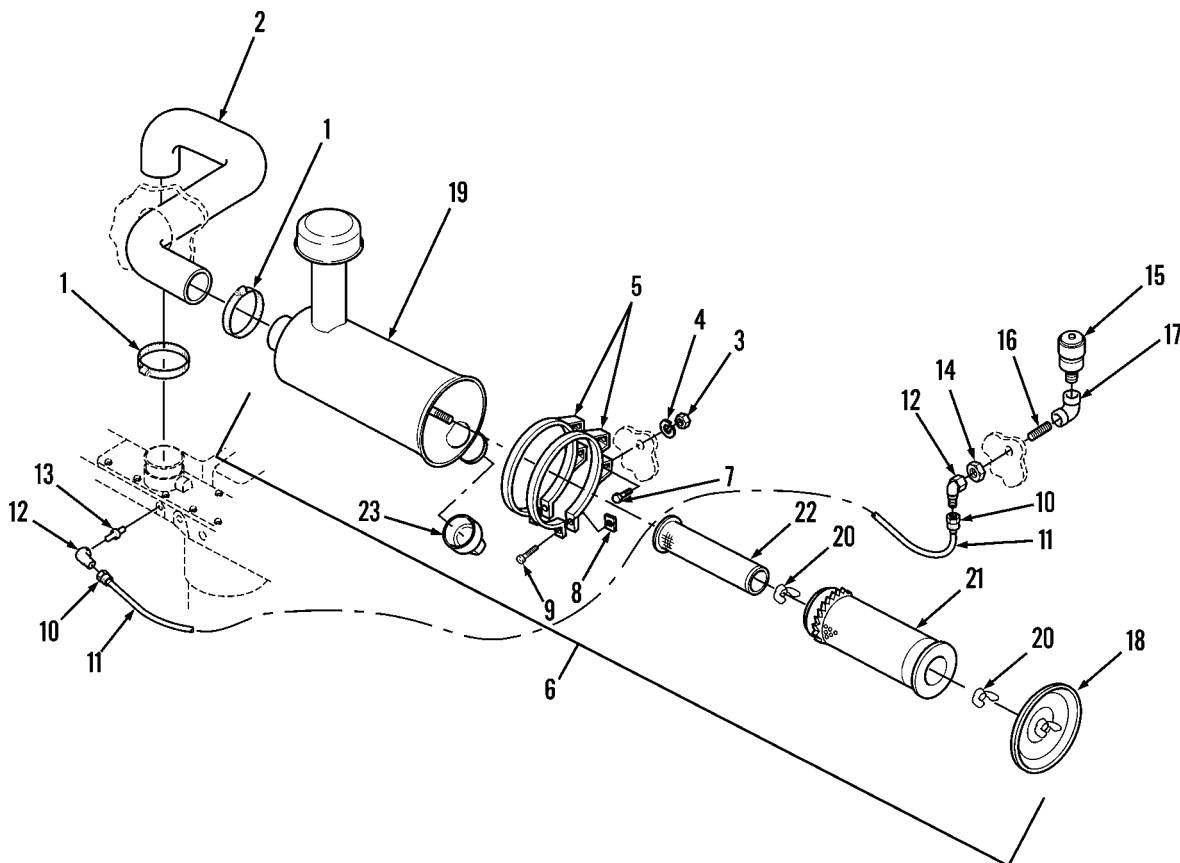

444-0049

Figure 1. Air Cleaner.



**REMOVAL - CONTINUED**

8. At engine cylinder head and hydraulic reservoir, left side, cut tiedown straps of tube (Figure 1, Item 11). Discard tiedown straps.
9. Disconnect two connectors (Figure 1, Item 10) of tube (Figure 1, Item 11) and remove tube from vehicle.
10. Remove two elbows (Figure 1, Item 12).
11. Remove filtered fitting (Figure 1, Item 13) from engine cylinder head.
12. Support indicator (Figure 1, Item 15) and remove nut (Figure 1, Item 14), pipe nipple (Figure 1, Item 16), and elbow (Figure 1, Item 17) from indicator.

**END OF TASK****DISASSEMBLY**

1. At air cleaner assembly (Figure 1, Item 6), loosen wing nut of end cap (Figure 1, Item 18) and remove end cap from body (Figure 1, Item 19).
2. Remove wing nut (Figure 1, Item 20) and filter element (Figure 1, Item 21) from body (Figure 1, Item 19).
3. Remove another wing nut (Figure 1, Item 20) and filter element (Figure 1, Item 22) from body (Figure 1, Item 19).
4. Remove evacuator (Figure 1, Item 23) from body (Figure 1, Item 19).

**END OF TASK****CLEANING****WARNING**

- Solvent cleaning compound MIL-PRF-680 Type III is an environmentally compliant and low toxic material. However, it may be irritating to the eyes and skin. Use protective gloves and goggles. Use in well-ventilated areas. Keep away from open flames and other sources of ignition. Failure to do so may result in injury or death to personnel.
  - Particles blown by compressed air are hazardous. **DO NOT** exceed 15 PSI (103 kPa) nozzle pressure when drying parts with compressed air. **DO NOT** exceed 30 PSI (207 kPa) nozzle pressure when cleaning parts with compressed air. **DO NOT** direct compressed air against human skin. Make sure air stream is directed away from user and other personnel in the area. To prevent injury, user must wear protective goggles or face shield. Failure to follow this warning may result in injury to personnel.
1. Clean filter elements (Figure 1, Items 21 and 22) by directing compressed air from **INSIDE** elements.
  2. Clean evacuator (Figure 1, Item 23) by rinsing with water. Dry thoroughly with compressed air.
  3. Clean all other parts with solvent cleaning compound. Dry thoroughly with compressed air.

**END OF TASK**

**INSPECTION**

1. Inspect filter elements (Figure 2, Items 21 and 22) by placing a light inside filter element. Replace element if clogged, damaged, has holes, or if gasket on end of element is damaged.
2. Inspect all other parts. Replace if cracked, dented, or damaged or threads are damaged.

**END OF TASK****ASSEMBLY**

1. Install evacuator (Figure 2, Item 23) on body (Figure 2, Item 19).
2. Install filter element (Figure 2, Item 22) and wing nut (Figure 2, Item 20) on body (Figure 2, Item 19).
3. Install filter element (Figure 2, Item 21) and other wing nut (Figure 2, Item 20) on body (Figure 2, Item 19).
4. Install end cap (Figure 2, Item 18) on body (Figure 2, Item 19) and tighten wing nut of end cap.

**END OF TASK****INSTALLATION**

1. At hydraulic reservoir, left side, and engine cylinder head, install elbow (Figure 2, Item 17) and pipe nipple (Figure 2, Item 16) on indicator (Figure 2, Item 15).
2. Install pipe nipple (Figure 2, Item 16) on vehicle with nut (Figure 2, Item 14).
3. At engine cylinder head, install filtered fitting (Figure 2, Item 13) on cylinder head.
4. Position tube (Figure 2, Item 11) on vehicle.
5. Connect two connectors (Figure 2, Item 10) of tube (Figure 2, Item 11) to two elbows (Figure 2, Item 12). Secure tube with new tiedown straps.
6. Position two mounting clamps (Figure 2, Item 5) on air cleaner assembly (Figure 2, Item 6).
7. Install two screws (Figure 2, Item 9) and two nuts (Figure 2, Item 8) on two mounting clamps (Figure 2, Item 5). Do not fully tighten nuts.
8. Position four screws (Figure 2, Item 7) and two mounting clamps (Figure 2, Item 5) on hood panel.
9. Install four new lockwashers (Figure 2, Item 4) and nuts (Figure 2, Item 3) on screws (Figure 2, Item 7).
10. Align air cleaner assembly (Figure 2, Item 6) so intake stack is pointing straight up. Tighten two nuts (Figure 2, Item 8).
11. Position two hose clamps (Figure 2, Item 1) on hose (Figure 2, Item 2).
12. Install hose (Figure 2, Item 2) on air cleaner assembly (Figure 2, Item 6) and engine intake manifold.
13. Tighten two hose clamps (Figure 2, Item 1).

INSTALLATION - CONTINUED

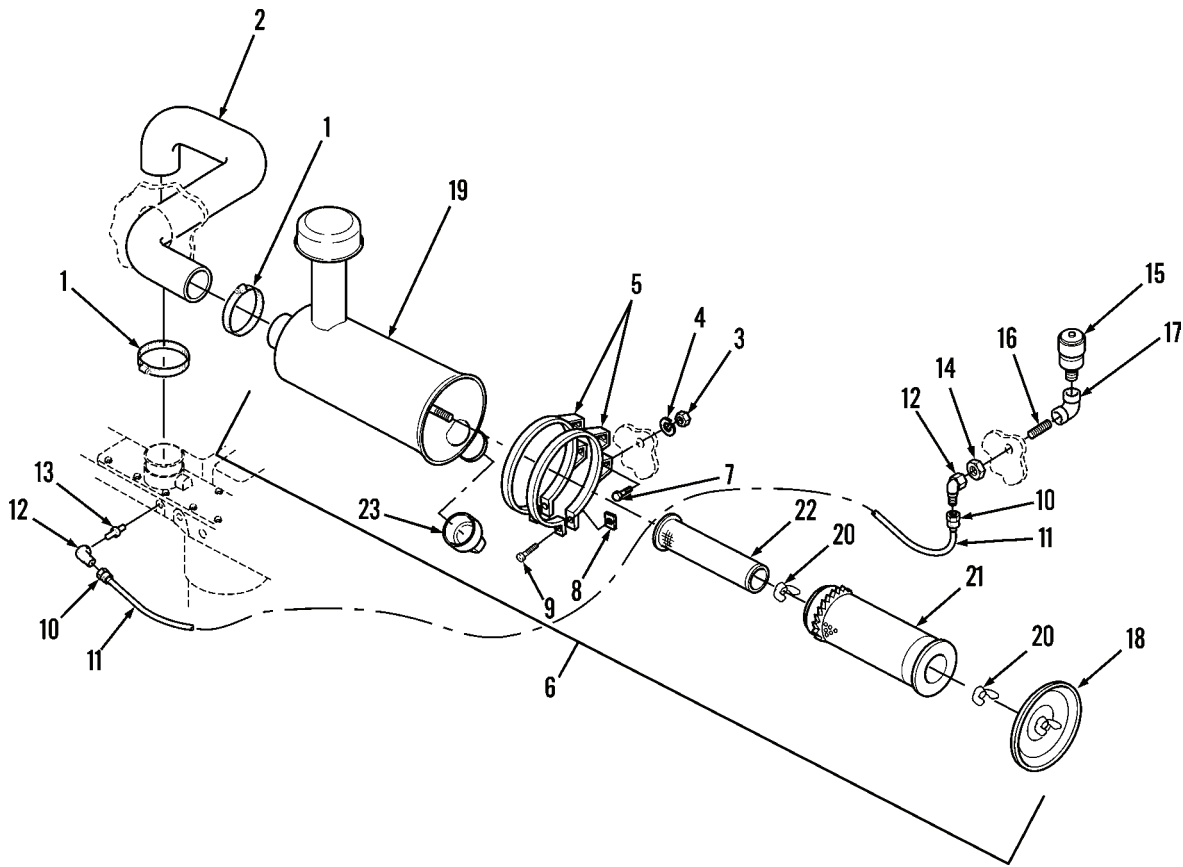

444-0049

Figure 2. Air Cleaner.

END OF TASK

END OF WORK PACKAGE



---

## ORGANIZATIONAL MAINTENANCE INSTRUCTIONS

### FUEL TANK SERVICING (MODEL 207)

Draining, Cleaning, Inspection, Filling

---

#### INITIAL SETUP

##### Maintenance Level

Organizational

##### Tools and Special Tools

Tool kit, general mechanic's (Item 15, WP 0309)  
Shop equipment, common no. 1 (Item 2, WP 0309)  
Container, 30-gal. capacity

##### Materials/Parts

Cleaning compound, solvent (Item 10, WP 0310)  
Rag, wiping (Item 26, WP 0310)

##### Materials/Parts - Continued

Strap, tiedown (Item 32, WP 0310)  
Gasket  
Lockwasher (5)

##### References

TM 10-3930-638-10

##### Equipment Condition

Left side panel removed (WP 0179)  
Fuel gage sending unit removed (WP 0117)

---

**DRAINING**

1. Remove fuel filler cap (Figure 1, Item 1).

**WARNING**

DO NOT smoke or permit any open flame in area of machine while you are servicing fuel system. Failure to follow this warning may result in injury or death to personnel or damage to equipment.

2. Position 30-gal. (114-L) container under drain plug (Figure 1, Item 2) of fuel tank.
3. Remove drain plug (Figure 1, Item 2) from bottom of fuel tank and allow fuel to drain into container.
4. Install drain plug (Figure 1, Item 2).

**NOTE**

- Perform step 5 if fuel tank is to be cleaned.
  - Remove rivnuts (Figure 1, Item 7) only if damaged.
5. At top of fuel tank, remove five capscrews (Figure 1, Item 3), lockwashers (Figure 1, Item 4), hand hole plate (Figure 1, Item 5), and gasket (Figure 1, Item 6). Discard lockwashers and gasket.

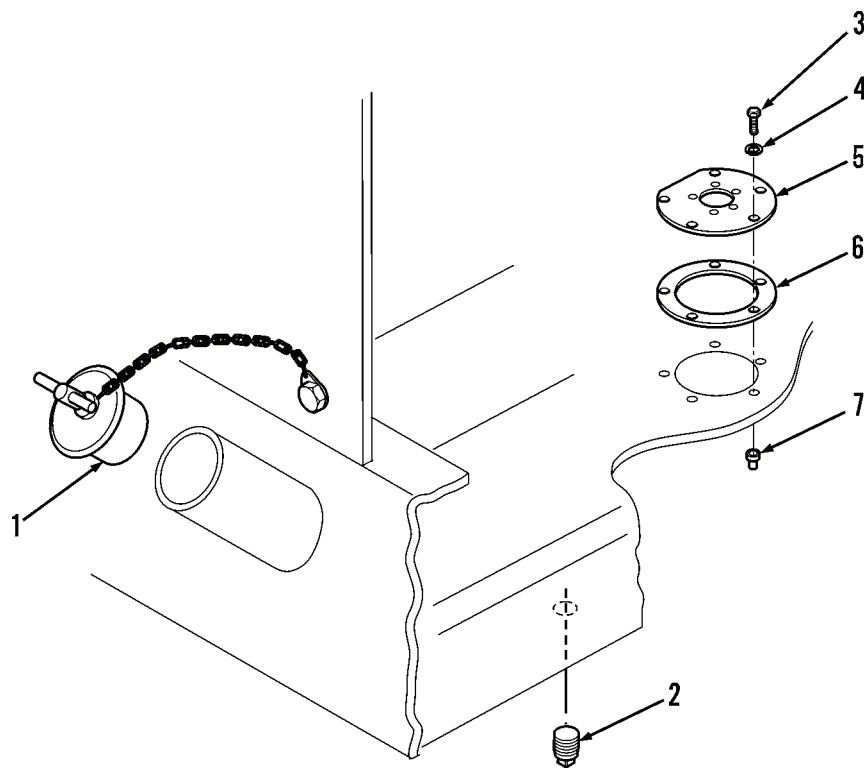

444-0054

**Figure 1. Components of Fuel Tank.**

**END OF TASK**

**CLEANING****WARNING**

Solvent cleaning compound MIL-PRF-680 Type III is an environmentally compliant and low toxic material. However, it may be irritating to the eyes and skin. Use protective gloves and goggles. Use in well-ventilated areas. Keep away from open flames and other sources of ignition. Failure to do so may result in injury or death to personnel.

1. Clean inside of fuel tank with clean rags moistened with solvent cleaning compound. Dry inside of fuel tank thoroughly.
2. Clean all other parts with solvent cleaning compound. Dry thoroughly.

**END OF TASK****INSPECTION**

Inspect all parts. Replace if cracked, bent, or threads are damaged.

**END OF TASK****FILLING****NOTE**

Perform step 1 if fuel tank was cleaned.

1. At top of fuel tank, install new gasket (Figure 1, Item 6) and hand hole plate (Figure 1, Item 5) with five new lockwashers (Figure 1, Item 4) and capscrews (Figure 1, Item 3).
2. Fill fuel tank with diesel fuel (TM 10-3930-638-10). Capacity is 27 gal. (102 L).
3. Install fuel filler cap (Figure 1, Item 1).

**END OF TASK****END OF WORK PACKAGE**





---

## ORGANIZATIONAL MAINTENANCE INSTRUCTIONS

### FUEL TANK SERVICING (MODEL 4-390)

Draining, Disassembly, Cleaning, Inspection, Assembly, Filling

---

#### INITIAL SETUP

##### Maintenance Level

Organizational

##### Tools and Special Tools

Tool kit, general mechanic's (Item 15, WP 0309)

Shop equipment, common no. 1 (Item 2, WP 0309)

Container, 30-gal. capacity

##### Materials/Parts

Cleaning compound, solvent (Item 10, WP 0310)

Rag, wiping (Item 26, WP 0310)

##### Materials/Parts - Continued

Gasket

Lockwasher (5)

##### References

TM 10-3930-638-10

##### Equipment Condition

Engine OFF

Left side panel removed (WP 0179)

Fuel gage sending unit removed (WP 0117)

Front cover panel removed (WP 0184)

---

**DRAINING**

1. At right rear of vehicle, remove filler cap (Figure 1, Item 1).

**WARNING**

Diesel fuel is highly combustible. DO NOT perform the following step while smoking or near fire, flames, or sparks. Fuel may ignite, causing injury or death to personnel or damage to equipment.

2. At bottom middle of fuel tank, position 30-gal. (114-L) container under drain plug (Figure 1, Item 2).

**NOTE**

Consult your unit/local hazardous waste disposal center or safety office for local regulatory guidance for disposal of fuel. If further information is needed, please contact the Army Environmental Hotline at 1-800-872-3845.

3. Remove drain plug (Figure 1, Item 2) and allow fuel to drain into container.

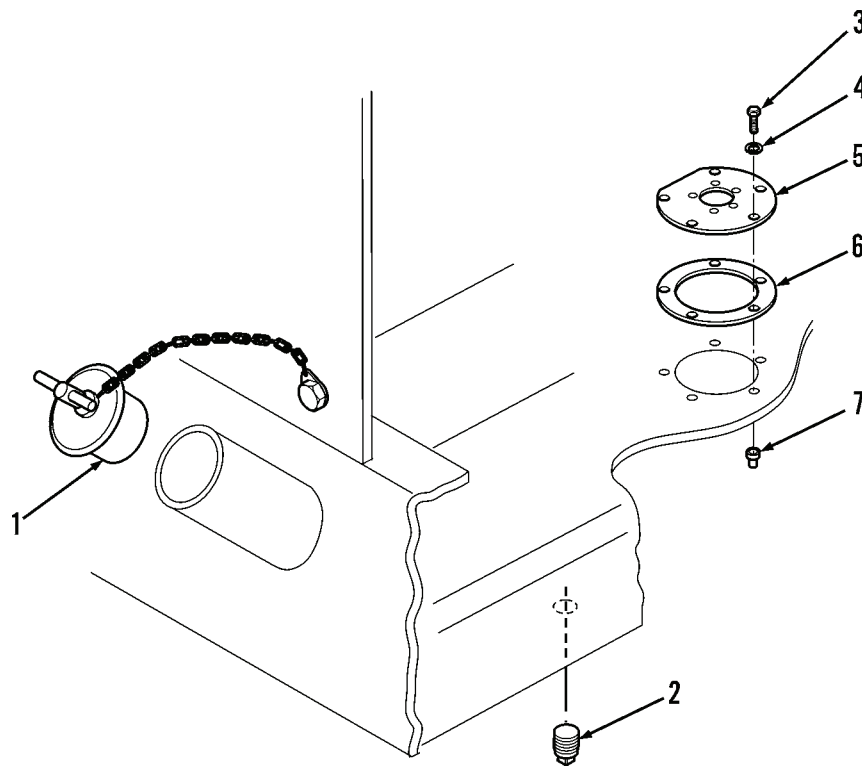

444-0054

**Figure 1. Drain Plug and Components.**

**END OF TASK**

**DISASSEMBLY****NOTE**

Five rivnuts (Figure 1, Item 7) are fastened permanently to fuel tank. Do not attempt to remove.

At top of fuel tank, remove five capscrews (Figure 1, Item 3), lockwashers (Figure 1, Item 4), hand hole plate (Figure 1, Item 5), and gasket (Figure 1, Item 6). Discard lockwashers.

**END OF TASK****CLEANING****WARNING**

Solvent cleaning compound MIL-PRF-680 Type III is an environmentally compliant and low toxic material. However, it may be irritating to the eyes and skin. Use protective gloves and goggles. Use in well-ventilated areas. Keep away from open flames and other sources of ignition. Failure to do so may result in injury or death to personnel.

1. Clean inside of fuel tank with clean rag moistened with solvent cleaning compound. Dry thoroughly.
2. Clean all other parts with solvent cleaning compound; dry thoroughly.

**END OF TASK****INSPECTION**

Inspect all parts. Replace if cracked, bent, or if threads are damaged.

**END OF TASK****ASSEMBLY**

1. Install new gasket (Figure 1, Item 6) and hand hole plate (Figure 1, Item 5) on top of fuel tank with five new lockwashers (Figure 1, Item 4) and capscrews (Figure 1, Item 3).
2. At bottom of fuel tank, install drain plug (Figure 1, Item 2).

**END OF TASK****FILLING**

1. At filler tube at right rear of vehicle, fill fuel tank with fuel (TM 10-3930-638-10).
2. Install fuel filler cap (Figure 1, Item 1).

**END OF TASK****END OF WORK PACKAGE**



---

## ORGANIZATIONAL MAINTENANCE INSTRUCTIONS

### FUEL TANK LINES AND FITTINGS REPLACEMENT (MODEL 207)

#### Removal, Cleaning, Inspection, Installation

---

#### INITIAL SETUP

**Maintenance Level**

Organizational

**Tools and Special Tools**

Tool kit, general mechanic's (Item 15, WP 0309)

Shop equipment, common no. 1 (Item 2, WP 0309)

**Materials/Parts**

Cleaning compound, solvent (Item 10, WP 0310)

**Materials/Parts - Continued**

Diesel fuel, arctic (Item 14, WP 0310)

Diesel fuel, DF-2 (Item 15, WP 0310)

Rag, wiping (Item 26, WP 0310)

Strap, tiedown (Item 32, WP 0310)

**Equipment Condition**

Right side panel removed (WP 0179)

---

**REMOVAL**

1. At right side of engine compartment, loosen two hose clamps (Figure 1, Item 1) and cut tiedown strap (Figure 1, Item 11). Discard tiedown strap.
2. Remove fuel return hose (Figure 1, Item 2) from between fuel return tube (Figure 1, Item 3) and tube (Figure 1, Item 5).
3. Loosen nut on fitting at fuel injection pump and remove fuel return tube (Figure 1, Item 3).
4. Loosen nut on fitting (Figure 1, Item 4) and remove tube (Figure 1, Item 5).
5. Remove fitting (Figure 1, Item 4) from top of fuel tank.
6. Loosen two hose clamps (Figure 1, Item 6) and remove fuel filter hose (Figure 1, Item 7) from between hose barb (Figure 1, Item 8) and in-line fuel filter.
7. Remove hose barb (Figure 1, Item 8), fuel shut-off valve (Figure 1, Item 9), and elbow (Figure 1, Item 10) from top of fuel tank.

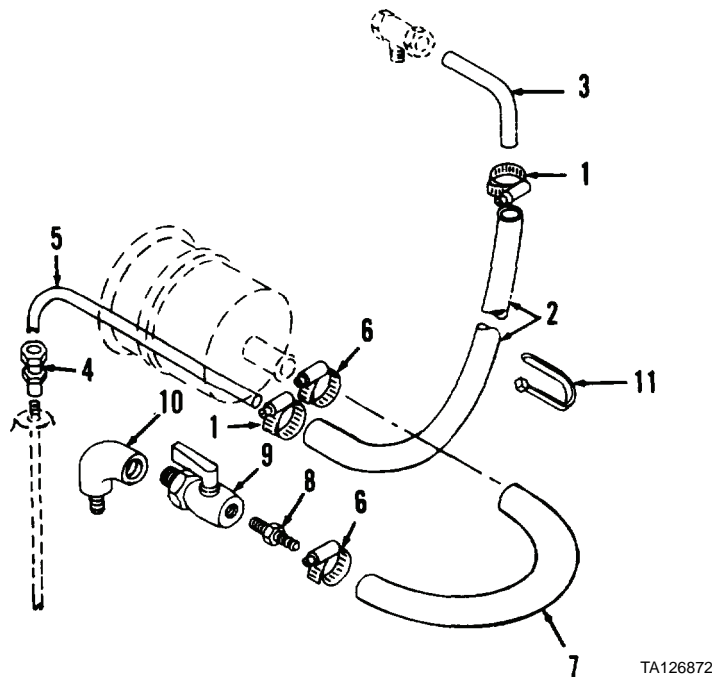
**Figure 1. Fuel Tank Lines.****END OF TASK**

**CLEANING****WARNING**

DO NOT clean using fuel while smoking or near fire, flames, or sparks. Fuel may ignite, causing damage to machine and injury or death to personnel.

1. Clean fuel return hose (Figure 1, Item 2) and fuel filter hose (Figure 1, Item 7) with clean diesel fuel. Dry thoroughly.

**WARNING**

Solvent cleaning compound MIL-PRF-680 Type III is an environmentally compliant and low toxic material. However, it may be irritating to the eyes and skin. Use protective gloves and goggles. Use in well-ventilated areas. Keep away from open flames and other sources of ignition. Failure to do so may result in injury or death to personnel.

2. Clean all other parts with solvent cleaning compound. Dry thoroughly.

**END OF TASK****INSPECTION**

1. Inspect fuel return hose (Figure 1, Item 2) and fuel filter hose (Figure 1, Item 7). Replace if cracked, split, or clogged.
2. Inspect fuel return tube (Figure 1, Item 3) and tube (Figure 1, Item 5). Replace if cracked, dented, or clogged.
3. Inspect all other parts. Replace if cracked or threads are damaged.

**END OF TASK****INSTALLATION**

1. Install elbow (Figure 1, Item 10), fuel shut-off valve (Figure 1, Item 9), and hose barb (Figure 1, Item 8) on top of fuel tank.
2. Install fuel filter hose (Figure 1, Item 7) between in-line fuel filter and hose barb (Figure 1, Item 8). Tighten two hose clamps (Figure 1, Item 6).
3. Install fitting (Figure 1, Item 4) on top of fuel tank.
4. Install tube (Figure 1, Item 5) on fitting (Figure 1, Item 4) and tighten nut of fitting.
5. Install fuel return tube (Figure 1, Item 3) on fitting of fuel injection pump and tighten nut of fitting.
6. Install fuel return hose (Figure 1, Item 2) between tube (Figure 1, Item 5) and fuel return tube (Figure 1, Item 3).
7. Tighten two hose clamps (Figure 1, Item 1) and install new tiedown strap (Figure 1, Item 11) around fuel return hose (Figure 1, Item 2) and wire of fuel injection pump.

**END OF TASK****END OF WORK PACKAGE**





---

## ORGANIZATIONAL MAINTENANCE INSTRUCTIONS

### FUEL TANK LINES AND FITTINGS REPLACEMENT (MODEL 4-390)

Removal, Cleaning, Inspection, Installation

---

#### INITIAL SETUP

##### Maintenance Level

Organizational

##### Tools and Special Tools

Tool kit, general mechanic's (Item 15, WP 0309)

Shop equipment, common no. 1 (Item 2, WP 0309)

##### Materials/Parts

Cleaning compound, solvent (Item 10, WP 0310)

Diesel fuel, arctic (Item 14, WP 0310)

Diesel fuel, DF-2 (Item 15, WP 0310)

Rag, wiping (Item 26, WP 0310)

##### Equipment Condition

Right side panel removed (WP 0179)

---

**REMOVAL**

1. At right rear of engine compartment, loosen hose clamp (Figure 1, Item 1) and disconnect fuel return hose (Figure 1, Item 2) from fuel injection pump.
2. Remove hose clamp (Figure 1, Item 1) from fuel return hose (Figure 1, Item 2).
3. At right side of engine, remove bolt (Figure 1, Item 3) and clamp (Figure 1, Item 4) from fuel return hose (Figure 1, Item 2).
4. At top of fuel tank, loosen hose clamp (Figure 1, Item 1) and remove fuel return hose (Figure 1, Item 2) from elbow (Figure 1, Item 5).
5. Remove hose clamp (Figure 1, Item 1) from fuel return hose (Figure 1, Item 2).
6. Remove elbow (Figure 1, Item 5) from top of fuel tank.

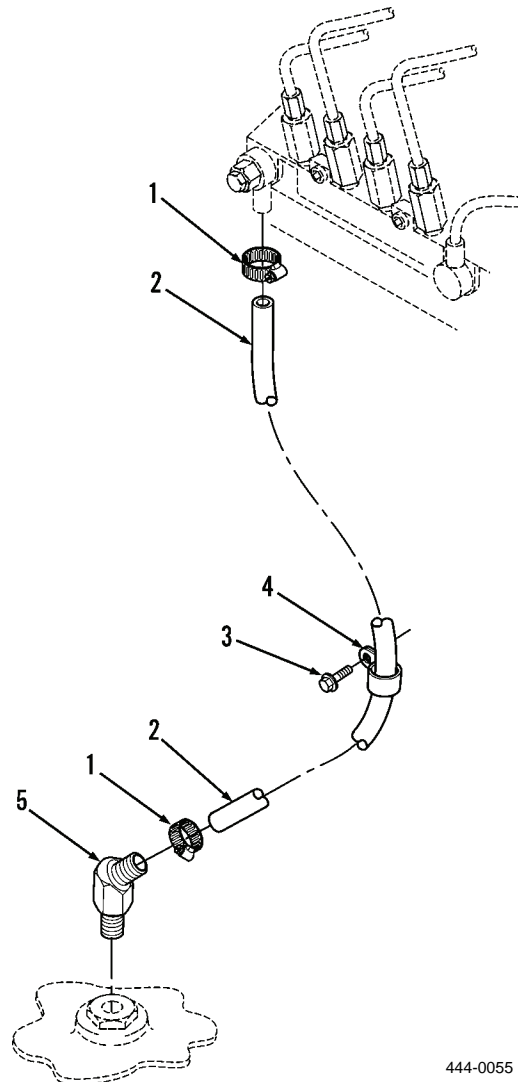

444-0055

**Figure 1. Lines and Fittings.****END OF TASK**

**CLEANING****WARNING**

DO NOT clean using diesel fuel while smoking or near fire, flames, or sparks. Fuel may ignite, causing damage to machine and injury or death to personnel.

1. Clean inside and outside of fuel return hose (Figure 1, Item 2) with clean diesel fuel. Dry thoroughly.

**WARNING**

Solvent cleaning compound MIL-PRF-680 Type III is an environmentally compliant and low toxic material. However, it may be irritating to the eyes and skin. Use protective gloves and goggles. Use in well-ventilated areas. Keep away from open flames and other sources of ignition. Failure to do so may result in injury or death to personnel.

2. Clean all other parts using solvent cleaning compound. Dry thoroughly.

**END OF TASK****INSPECTION**

1. Inspect fuel return hose (Figure 1, Item 2). Replace if cracked or split.
2. Inspect all other parts. Replace if damaged, cracked, or threads are damaged.

**END OF TASK****INSTALLATION**

1. Install elbow (Figure 1, Item 5) on top of fuel tank.
2. Position hose clamp (Figure 1, Item 1) on fuel return hose (Figure 1, Item 2).
3. Install fuel return hose (Figure 1, Item 2) on elbow (Figure 1, Item 5). Tighten hose clamp (Figure 1, Item 1).
4. At right side of engine, install clamp (Figure 1, Item 4) and bolt (Figure 1, Item 3) on fuel return hose (Figure 1, Item 2).
5. Position clamp (Figure 1, Item 1) to fuel return hose (Figure 1, Item 2).
6. Connect fuel return hose (Figure 1, Item 2) to fuel injection pump. Tighten hose clamp (Figure 1, Item 1).

**END OF TASK****END OF WORK PACKAGE**



---

## ORGANIZATIONAL MAINTENANCE INSTRUCTIONS

### IN-LINE FUEL FILTER REPLACEMENT (MODEL 207)

#### Removal, Installation

---

#### INITIAL SETUP

**Maintenance Level**

Organizational

**Tools and Special Tools**

Tool kit, general mechanic's (Item 15, WP 0309)

Shop equipment, common no. 1 (Item 2, WP 0309)

**Materials Parts**

In-line fuel filter

**References**

WP 0069

**Equipment Condition**

Right side panel removed (WP 0179)

---

**REMOVAL****WARNING**

DO NOT smoke or permit any open flame in area of machine while you are servicing fuel system. Failure to follow this warning may result in injury or death to personnel, or damage to equipment.

1. At right rear of engine compartment, loosen two hose clamps (Figure 1).
2. Remove in-line fuel filter from two hoses.

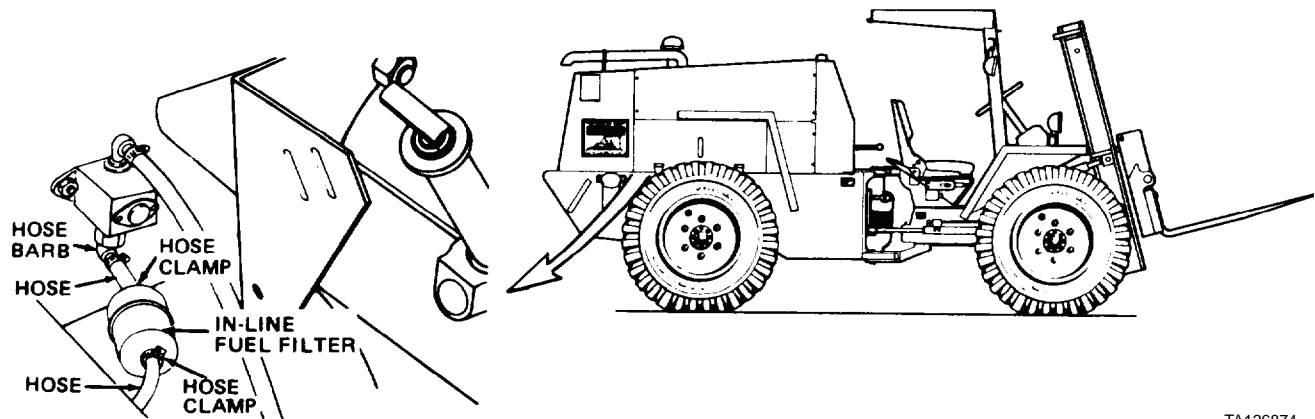

TA126874

**Figure 1. In-Line Fuel Filter.**

**END OF TASK****INSTALLATION**

1. Install in-line fuel filter on two hoses.
2. Tighten two hose clamps.
3. Bleed air from secondary fuel filter (WP 0069).

**END OF TASK****END OF WORK PACKAGE**

---

## ORGANIZATIONAL MAINTENANCE INSTRUCTIONS

### IN-LINE FUEL FILTER REPLACEMENT (MODEL 4-390)

#### Removal, Installation

---

#### INITIAL SETUP

**Maintenance Level**

Organizational

**Tools and Special Tools**

Tool kit, general mechanic's (Item 15, WP 0309)

Shop equipment, common no. 1 (Item 2, WP 0309)

**Materials/Parts**

Rag, wiping (Item 26, WP 0310)

In-line fuel filter

**References**

WP 0072

**Equipment Condition**

Engine OFF

Right side panel removed (WP 0179)

---

**REMOVAL**

1. At right rear of engine compartment, loosen two hose clamps (Figure 1, Item 1).
2. Disconnect two hoses (Figure 1, Item 2) from in-line fuel filter (Figure 1, Item 3). Discard in-line fuel filter.
3. Remove two hose clamps (Figure 1, Item 1) from two hoses (Figure 1, Item 2).

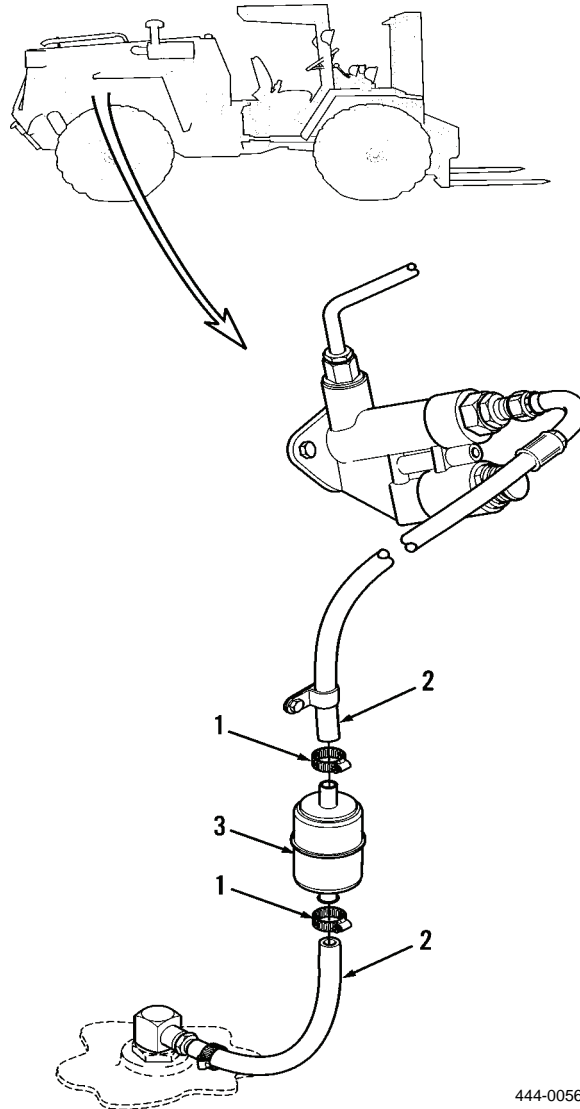

444-0056

**Figure 1. In-Line Fuel Filter.****END OF TASK****INSTALLATION**

1. Position two hose clamps (Figure 1, Item 1) on hoses (Figure 1, Item 2).
2. Connect in-line fuel filter (Figure 1, Item 3) to hoses (Figure 1, Item 2).
3. Tighten two hose clamps (Figure 1, Item 1).
4. Bleed air from fuel system (WP 0072).

**END OF TASK****END OF WORK PACKAGE**



---

## ORGANIZATIONAL MAINTENANCE INSTRUCTIONS

### FUEL FILTER MAINTENANCE (MODEL 207)

Removal, Cleaning, Inspection, Installation,  
Bleeding Air, Draining Moisture

---

#### INITIAL SETUP

##### Maintenance Level

Organizational

##### Tools and Special Tools

Tool kit, general mechanic's (Item 15, WP 0309)

Shop equipment, common no. 1 (Item 2, WP 0309)

Container, 1-gal. capacity

##### Materials/Parts

Cleaning compound, solvent (Item 10, WP 0310)

Rag, wiping (Item 26, WP 0310)

Fuel filter kit

Lockwasher (3)

O-ring (2)

##### Equipment Condition

Right side panel removed (WP 0179)

Fuel tank shut-off valve closed

---

## REMOVAL

**WARNING**

DO NOT smoke or permit any open flame in area of machine while you are servicing fuel system. Failure to follow this warning may result in injury or death to personnel, or damage to equipment.

1. At right side of engine compartment, place container under primary fuel filter (Figure 1, Item 3).
2. Remove drain plug (Figure 1, Item 1) and O-ring (Figure 1, Item 2). Allow fuel to drain into 1-gal. (3.78-L) container. Discard O-ring.
3. Remove primary fuel filter (Figure 1, Item 3) from filter head (Figure 1, Item 10). Discard primary fuel filter.
4. Remove bleed valve plug (Figure 1, Item 4) and O-ring (Figure 1, Item 5) from secondary fuel filter (Figure 1, Item 6).
5. Remove secondary fuel filter (Figure 1, Item 6) and stud gasket (Figure 1, Item 7) from filter head (Figure 1, Item 10).
6. Remove three capscrews (Figure 1, Item 8) and lockwashers (Figure 1, Item 9) to separate filter head (Figure 1, Item 10) from engine. Discard lockwashers.

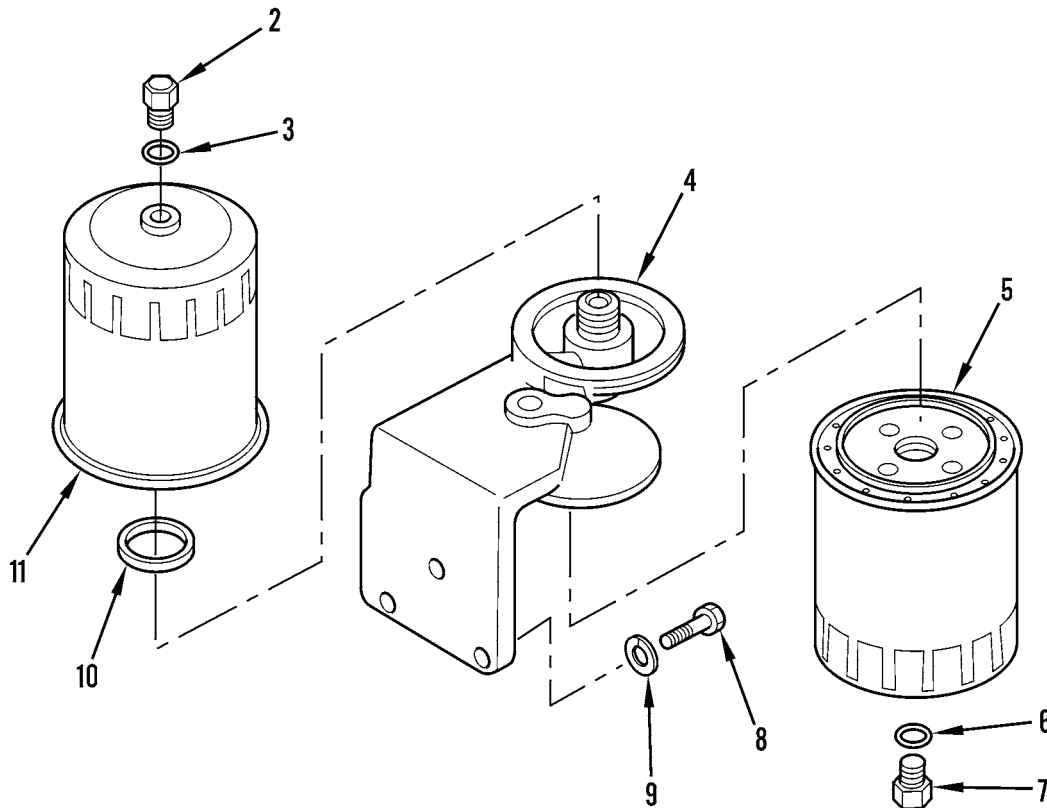

444-024

Figure 1. Fuel Filters.

**REMOVAL - CONTINUED**

7. Remove hose clamp, hose, and elbow from filter head (Figure 2).
8. Disconnect fuel filter from fuel injection pump tube and remove elbow from filter head.
9. Remove filter head (Figure 1, Item 10) from vehicle.

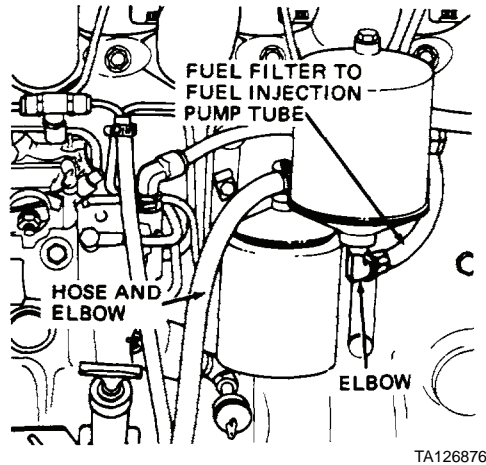

Figure 2. Fuel Lines and Fittings.

**END OF TASK****CLEANING**

**WARNING**



Solvent cleaning compound MIL-PRF-680 Type III is an environmentally compliant and low toxic material. However, it may be irritating to the eyes and skin. Use protective gloves and goggles. Use in well-ventilated areas. Keep away from open flames and other sources of ignition. Failure to do so may result in injury or death to personnel.

1. Clean filter head with solvent cleaning compound. Dry thoroughly.
2. Clean all other parts with solvent cleaning compound.

**END OF TASK****INSPECTION**

1. Inspect filter head. Replace if cracked or threads are damaged.
2. Inspect all other parts. Replace if threads are damaged.

**END OF TASK**

---

**INSTALLATION**

1. Position filter head (Figure 3, Item 10) on engine.
2. Install elbow and connect fuel filter to fuel injection pump tube.
3. Install elbow, hose, and hose clamp on filter head (Figure 3, Item 10).
4. Install filter head (Figure 3, Item 10) on engine with three new lockwashers (Figure 3, Item 9) and capscrews (Figure 3, Item 8).
5. Apply thin coat of diesel fuel to gasket of new secondary fuel filter (Figure 3, Item 6). Position new stud gasket (Figure 3, Item 7) and new secondary fuel filter on filter head (Figure 3, Item 10).
6. Tighten filter (Figure 3, Item 6) until gasket contacts filter head (Figure 3, Item 10), then tighten 1/2 turn. Loosen filter and retighten 1/2 to 3/4 turn to obtain proper seal.
7. Install new O-ring (Figure 3, Item 5) and bleed valve plug (Figure 3, Item 4) on secondary fuel filter (Figure 3, Item 6).
8. Apply thin coat of diesel fuel to gasket of new primary fuel filter (Figure 3, Item 3). Position new primary fuel filter on filter head (Figure 3, Item 10).

**END OF TASK****BLEEDING AIR**

1. At secondary fuel filter (Figure 3, Item 6), loosen bleed valve plug (Figure 3, Item 4).
2. Place ignition switch in ON position and observe fuel and air bubbles flowing from bleed valve plug (Figure 3, Item 4).
3. When fuel is free of air bubbles, tighten bleed valve plug (Figure 3, Item 4).
4. Place ignition switch in OFF position.

**END OF TASK**

**DRAINING MOISTURE**

1. At primary fuel filter (Figure 3, Item 3), loosen drain plug (Figure 3, Item 1).
2. Allow water and fuel to drain into container until free of water.
3. Tighten drain plug (Figure 3, Item 1).
4. Bleed air from filters (see *Bleeding Air* in this work package).

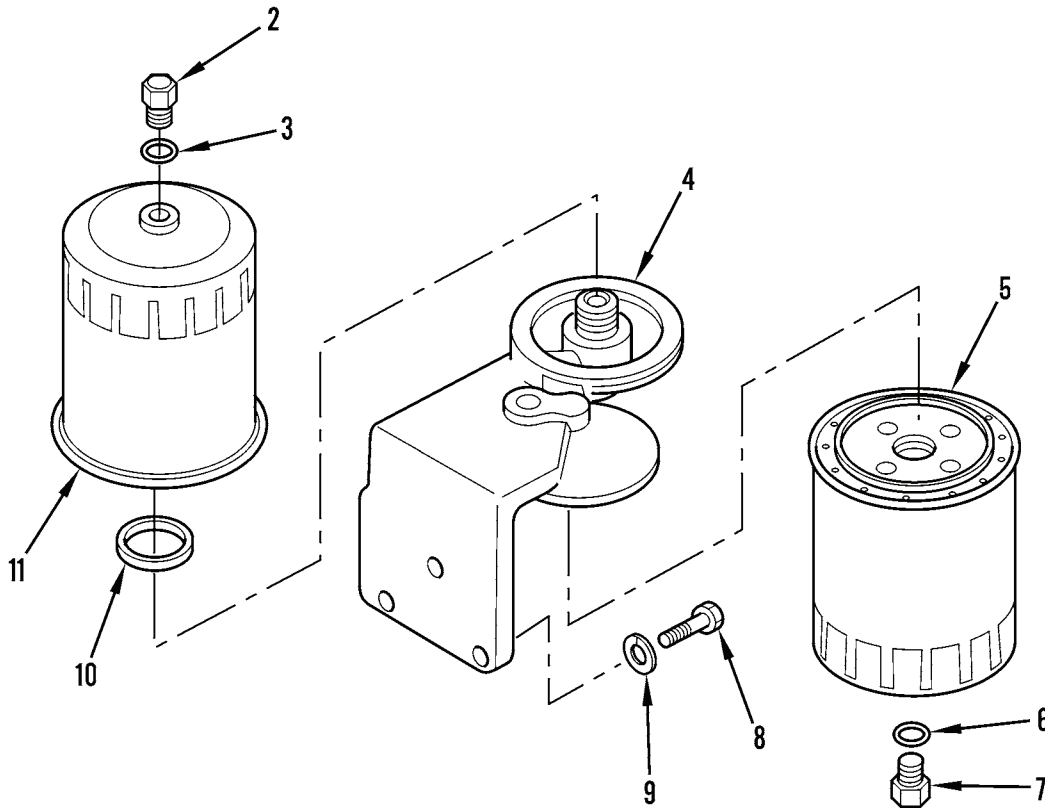

444-024

**Figure 3. Fuel Filters.****END OF TASK****END OF WORK PACKAGE**



---

## ORGANIZATIONAL MAINTENANCE INSTRUCTIONS

### FUEL TANK STRAINER REPLACEMENT (MODEL 207)

Removal, Cleaning, Inspection, Installation

---

#### INITIAL SETUP

##### Maintenance Level

Organizational

##### Tools and Special Tools

Tool kit, general mechanic's (Item 15, WP 0309)  
Shop equipment, common no. 1 (Item 2, WP 0309)

##### Materials/Parts

Cap set, protective (Item 9, WP 0310)  
Cleaning compound, solvent (Item 10, WP 0310)  
Lubricating oil, OE/HDO-15/40 (Item 21, WP 0310)  
Rag, wiping (Item 26, WP 0310)

##### Equipment Condition

Right side panel removed (WP 0179)  
Fuel tank shut-off valve closed

---

**REMOVAL**

1. At right rear of engine compartment, loosen hose clamp (Figure 1, Item 1).
2. Disconnect fuel filter hose (Figure 1, Item 2) from hose barb (Figure 1, Item 3) and immediately insert a plug into end of fuel filter hose to prevent flow of diesel fuel.
3. Remove hose barb (Figure 1, Item 3), fuel shut-off valve (Figure 1, Item 4), and elbow (Figure 1, Item 5) from fuel strainer (Figure 1, Item 6).
4. Remove fuel strainer (Figure 1, Item 6) from top of fuel tank.

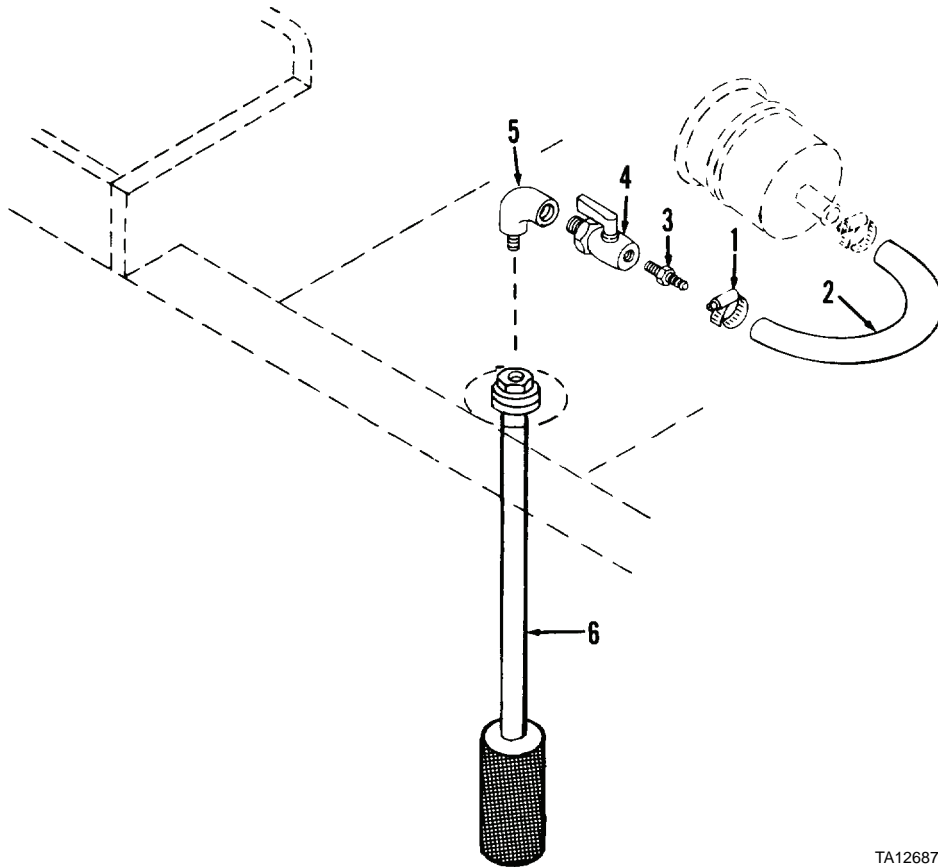

TA126877

**Figure 1. Fuel Tank Strainer Assembly.****END OF TASK**



**CLEANING****WARNING**

- Solvent cleaning compound MIL-PRF-680 Type III is an environmentally compliant and low toxic material. However, it may be irritating to the eyes and skin. Use protective gloves and goggles. Use in well-ventilated areas. Keep away from open flames and other sources of ignition. Failure to do so may result in injury or death to personnel.
  - Particles blown by compressed air are hazardous. DO NOT exceed 15 PSI (103 kPa) nozzle pressure when drying parts with compressed air. DO NOT direct compressed air against human skin. Make sure air stream is directed away from user and other personnel in the area. To prevent injury, user must wear protective goggles or face shield. Failure to follow this warning may result in injury to personnel.
1. Clean fuel tank strainer (Figure 1, Item 6) with solvent cleaning compound. Immerse and move up and down to dissolve foreign material and loosen particles of debris. Dry with compressed air.
  2. Clean all other parts with solvent cleaning compound. Ensure holes through parts are clean and free of debris. Dry thoroughly.

**END OF TASK****INSPECTION**

1. Inspect fuel tank strainer. Replace if damaged or screen is clogged, torn, or distorted.
2. Inspect fuel shut-off valve. Replace if damaged, lever is hard to rotate, or threads are damaged.
3. Inspect all other parts. Replace if cracked, split, or damaged.

**END OF TASK****INSTALLATION**

1. Install fuel strainer (Figure 1, Item 6) on top of fuel tank.
2. Install elbow (Figure 1, Item 5), fuel shut-off valve (Figure 1, Item 4), and hose barb (Figure 1, Item 3) on fuel stainer (Figure 1, Item 6).
3. Remove plug from end of fuel filter hose (Figure 1, Item 2) and immediately connect fuel filter hose to hose barb (Figure 1, Item 3).
4. Tighten hose clamp (Figure 1, Item 1).
5. Ensure lever of fuel shut-off valve (Figure 1, Item 4) is rotated to ON position.

**END OF TASK****END OF WORK PACKAGE**



---

## ORGANIZATIONAL MAINTENANCE INSTRUCTIONS

### FUEL TANK STRAINER REPLACEMENT (MODEL 4-390)

Removal, Cleaning, Inspection, Installation

---

#### INITIAL SETUP

##### Maintenance Level

Organizational

##### Tools and Special Tools

Tool kit, general mechanic's (Item 15, WP 0309)

Shop equipment, common no. 1 (Item 2, WP 0309)

Container, 1-gal. capacity

##### Materials/Parts

Cap set, protective (Item 9, WP 0310)

##### Materials/Parts - Continued

Cleaning compound, solvent (Item 10, WP 0310)

Rag, wiping (Item 26, WP 0310)

##### References

WP 0072

##### Equipment Condition

Engine OFF

Right side panel removed (WP 0179)

---

**REMOVAL**

1. At right side of engine compartment, loosen hose clamp (Figure 1, Item 1).
2. Disconnect fuel filter hose (Figure 1, Item 2) from hose barb (Figure 1, Item 3). Allow diesel fuel and water to drain into container.
3. Remove hose clamp (Figure 1, Item 1) from end of fuel filter hose (Figure 1, Item 2) and install cap.
4. At top of fuel tank, remove hose barb (Figure 1, Item 3) and elbow (Figure 1, Item 4) from fuel strainer (Figure 1, Item 5).
5. Remove fuel strainer (Figure 1, Item 5) from fuel tank.

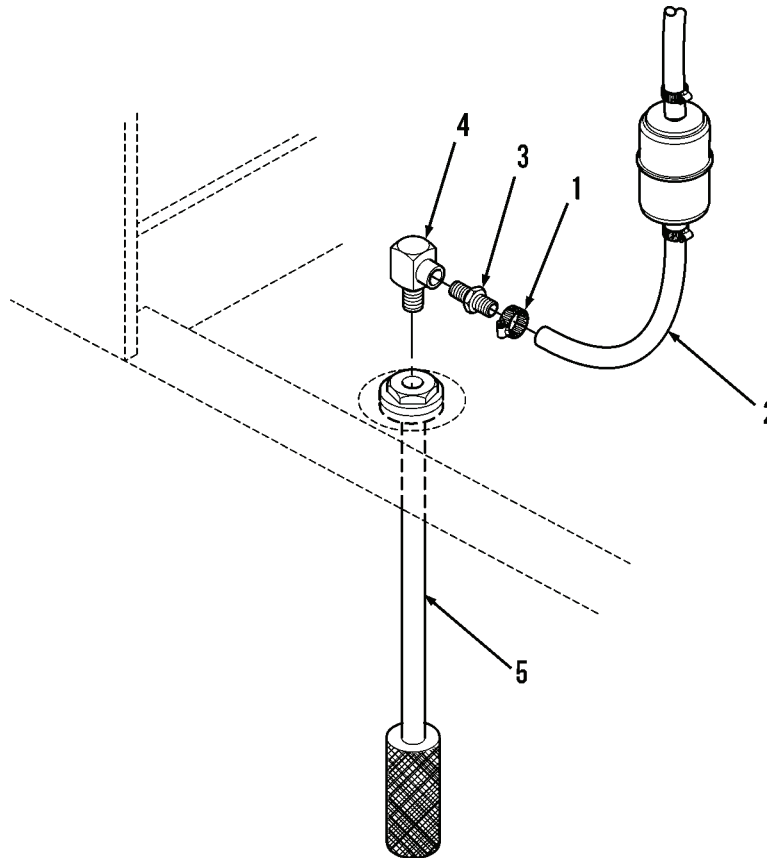

444-0058

**Figure 1. Fuel Tank Strainer Assembly.****END OF TASK**

**CLEANING**

- Solvent cleaning compound MIL-PRF-680 Type III is an environmentally compliant and low toxic material. However, it may be irritating to the eyes and skin. Use protective gloves and goggles. Use in well-ventilated areas. Keep away from open flames and other sources of ignition. Failure to do so may result in injury or death to personnel.
  - Particles blown by compressed air are hazardous. DO NOT exceed 15 PSI (103 kPa) nozzle pressure when drying parts with compressed air. DO NOT direct compressed air against human skin. Make sure air stream is directed away from user and other personnel in the area. To prevent injury, user must wear protective goggles or face shield. Failure to follow this warning may result in injury to personnel.
1. Clean fuel strainer with solvent (Figure 1, Item 5) cleaning compound. Immerse and move slowly up and down until all foreign material is dissolved. Dry thoroughly with compressed air.
  2. Clean all other parts with solvent cleaning compound. Dry thoroughly.

**END OF TASK****INSPECTION**

1. Inspect fuel strainer (Figure 1, Item 5). Replace if damaged or if screen is deformed or torn.
2. Inspect all other parts. Replace if damaged.

**END OF TASK****INSTALLATION**

1. At right side of engine compartment, install fuel strainer (Figure 1, Item 5) in fuel tank.
2. Install elbow (Figure 1, Item 4) and hose barb (Figure 1, Item 3) on fuel strainer (Figure 1, Item 5).
3. Position hose clamp (Figure 1, Item 1) on fuel filter hose (Figure 1, Item 2).
4. Uncap and connect fuel filter hose (Figure 1, Item 2) to hose barb (Figure 1, Item 3).
5. Tighten hose clamp (Figure 1, Item 1).
6. Bleed air from fuel system (WP 0072).

**END OF TASK****END OF WORK PACKAGE**



---

## ORGANIZATIONAL MAINTENANCE INSTRUCTIONS

### FUEL FILTER SERVICING AND REPLACEMENT (MODEL 4-390)

Removal, Cleaning, Inspection, Installation, Bleeding Air, Draining Moisture

---

#### INITIAL SETUP

##### Maintenance Level

Organizational

##### Tools and Special Tools

Tool kit, general mechanic's (Item 15, WP 0309)

Shop equipment, common no. 1 (Item 2, WP 0309)

Container, 1-gal. capacity

##### Materials/Parts

Cleaning compound, solvent (Item 10, WP 0310)

##### Materials/Parts - Continued

Lubricating oil, OE/HDO-15/40 (Item 21, WP 0310)

Rag, wiping (Item 26, WP 0310)

Fuel filter

##### References

WP 0219

##### Equipment Condition

Engine OFF

Right side panel removed (WP 0179)

---

**REMOVAL****NOTE**

Consult your unit/local hazardous waste disposal center or safety office for local regulatory guidance for disposal of fuel. If further information is needed, please contact the Army Environmental Hotline at 1-800-872-3845.

1. At right side of engine compartment, rotate drain valve (Figure 1, Item 1) of fuel filter (Figure 1, Item 2) to OPEN position.
2. Allow diesel fuel and water to drain into container.
3. Using filter wrench, remove fuel filter (Figure 1, Item 2) from cylinder head. Discard fuel filter.

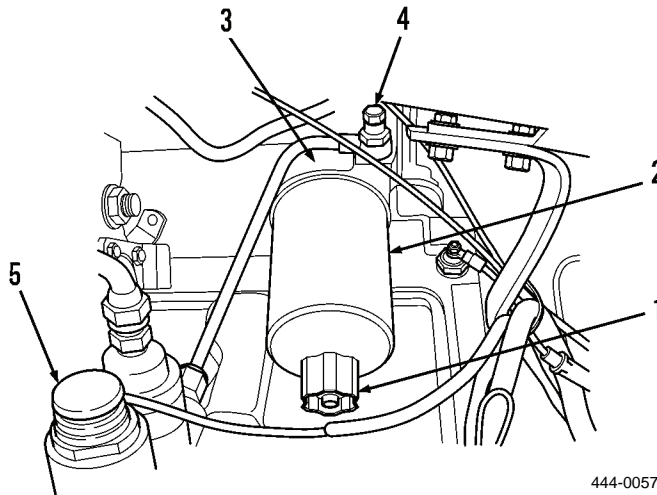

**Figure 1. Fuel Filter Assembly.**

**END OF TASK****CLEANING**

Solvent cleaning compound MIL-PRF-680 Type III is an environmentally compliant and low toxic material. However, it may be irritating to the eyes and skin. Use protective gloves and goggles. Use in well-ventilated areas. Keep away from open flames and other sources of ignition. Failure to do so may result in injury or death to personnel.

Clean mating surface of cylinder head with solvent cleaning compound. Dry thoroughly.

**END OF TASK****INSPECTION**

Inspect cylinder head for damage. Replace if damaged (WP 0219).

**END OF TASK**



---

**INSTALLATION**

1. Apply clean engine oil to gasket of new fuel filter (Figure 1, Item 2).
2. Position fuel filter (Figure 1, Item 2) on cylinder head. Tighten fuel filter until gasket (Figure 1, Item 3) contacts cylinder head. Then, tighten an additional 1/2 turn. Loosen fuel filter and retighten 1/2 to 3/4 turn to obtain proper seal.

**END OF TASK****BLEEDING AIR**

1. At cylinder head, loosen bleed screw (Figure 1, Item 4).
2. Actuate fuel primer pump (Figure 1, Item 5). When clear fuel with no air bubbles flows from around bleed screw (Figure 1, Item 4), tighten bleed screw.

**END OF TASK****DRAINING MOISTURE**

1. At bottom of fuel filter (Figure 1, Item 2), loosen drain valve (Figure 1, Item 1).
2. Allow diesel fuel to drain into container until free of water. Then, tighten drain valve (Figure 1, Item 1).

**END OF TASK****END OF WORK PACKAGE**



---

## ORGANIZATIONAL MAINTENANCE INSTRUCTIONS

### QUICK START KIT REPLACEMENT Removal, Cleaning, Inspection, Installation

---

#### INITIAL SETUP

**Maintenance Level**

Organizational

**Tools and Special Tools**

Tool kit, general mechanic's (Item 15, WP 0309)

Shop equipment, common no. 1 (Item 2, WP 0309)

**Materials/Parts**

Cleaning compound, solvent (Item 10, WP 0310)

**Materials/Parts - Continued**

Rag, wiping (Item 26, WP 0310)

Cotter pin

Lockwasher (8)

Quick start kit

**Equipment Condition**

Left side panel removed (WP 0179)

Front cover panel removed (WP 0184)

---

**REMOVAL**

1. At engine intake manifold, loosen nut (Figure 1, Item 1) and disconnect tube (Figure 1, Item 2) from spray nozzle (Figure 1, Item 3).
2. Remove spray nozzle (Figure 1, Item 3), adapter (Figure 1, Item 4), and washer (Figure 1, Item 5) from engine intake manifold.
3. In engine compartment, remove two clamps (Figure 1, Item 6) from tube (Figure 1, Item 2).
4. At other end of tube (Figure 1, Item 2), loosen nut (Figure 1, Item 7), and remove tube from vehicle.
5. Remove two wing nuts (Figure 1, Item 8), lockwashers (Figure 1, Item 9), and clamp (Figure 1, Item 10) from cylinder (Figure 1, Item 11). Discard lockwashers.

**WARNING**

Cylinder contains starting fluid which is highly flammable and under pressure. Do not puncture cylinder or discard in an open fire. Failure to follow this warning may result in injury or death to personnel.

6. Remove cylinder (Figure 1, Item 11) from valve (Figure 1, Item 15).
7. Remove two capscrews (Figure 1, Item 12), clamp (Figure 1, Item 13), cotter pin (Figure 1, Item 14), and valve (Figure 1, Item 15) from mounting bracket (Figure 1, Item 26). Discard cotter pin.
8. Remove connector (Figure 1, Item 16) from valve (Figure 1, Item 15).
9. Remove two nuts (Figure 1, Item 17), lockwashers (Figure 1, Item 18), bracket (Figure 1, Item 22), and two studs (Figure 1, Item 19) from vehicle. Discard lockwashers.
10. Remove two lockwashers (Figure 1, Item 20) and nuts (Figure 1, Item 21) from studs (Figure 1, Item 19). Discard lockwashers.
11. Remove two nuts (Figure 1, Item 23), lockwashers (Figure 1, Item 24), screws (Figure 1, Item 25), and mounting bracket (Figure 1, Item 26) from vehicle. Discard lockwashers.

**END OF TASK****CLEANING****WARNING**

Solvent cleaning compound MIL-PRF-680 Type III is an environmentally compliant and low toxic material. However, it may be irritating to the eyes and skin. Use protective gloves and goggles. Use in well-ventilated areas. Keep away from open flames and other sources of ignition. Failure to do so may result in injury or death to personnel.

Clean all parts with solvent cleaning compound. Dry thoroughly.

## CLEANING - CONTINUED

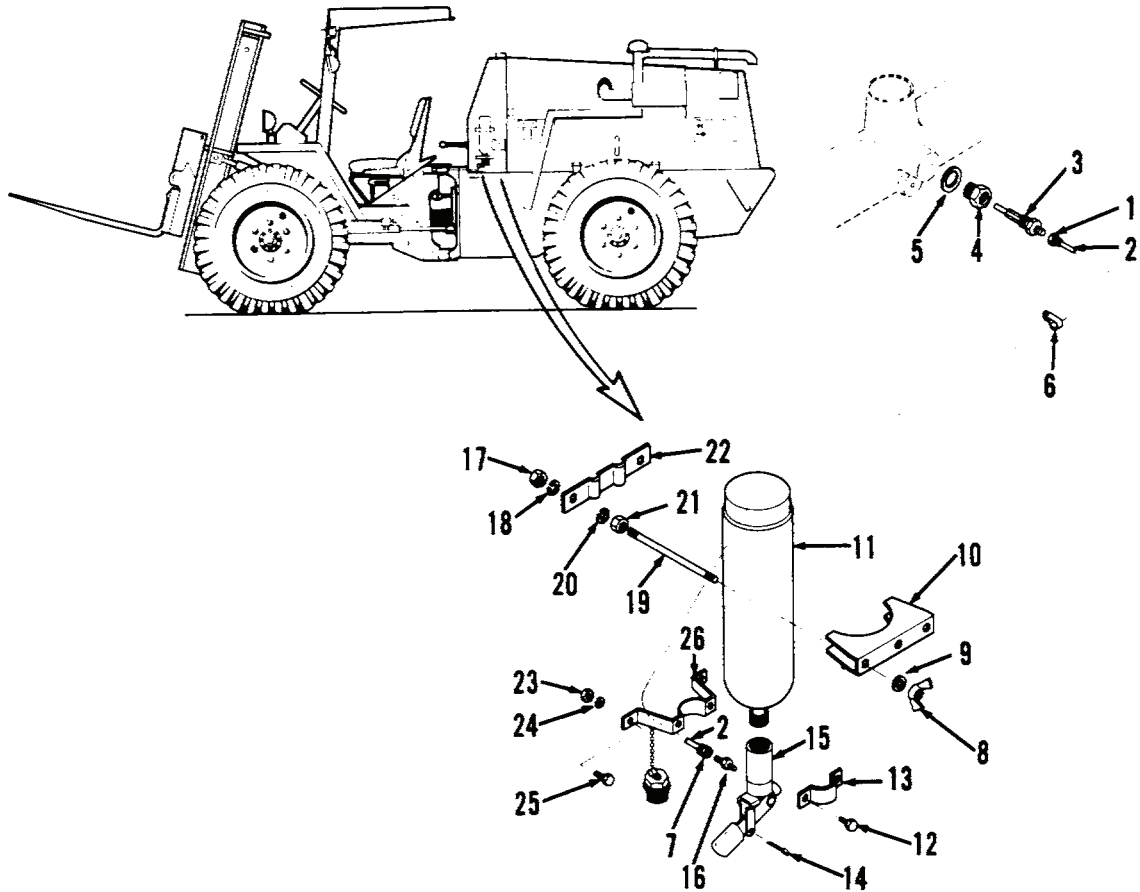

TA126878

Figure 1. Quick Start Kit.

## END OF TASK

## INSPECTION

1. Inspect clamps and brackets. Replace if damaged.
2. Inspect tube. Replace if cracked or crushed.
3. Inspect cylinder. Replace if dented or empty.
4. Inspect all other parts. Replace if damaged.

## END OF TASK

**INSTALLATION**

1. At left side of vehicle, install mounting bracket (Figure 2, Item 26) with two screws (Figure 2, Item 25), new lockwashers (Figure 2, Item 24), and nuts (Figure 2, Item 23).
2. Position two nuts (Figure 2, Item 21) and new lockwashers (Figure 2, Item 24) on studs (Figure 2, Item 19).
3. Install two studs (Figure 2, Item 19) and bracket (Figure 2, Item 22) on vehicle with two new lockwashers (Figure 2, Item 18) and nuts (Figure 2, Item 17).
4. Install connector (Figure 2, Item 16) on valve (Figure 2, Item 15).
5. Install valve (Figure 2, Item 15), new cotter pin (Figure 2, Item 14), and clamp (Figure 2, Item 13) on mounting bracket (Figure 2, Item 26) with two capscrews (Figure 2, Item 12).
6. Install cylinder (Figure 2, Item 11) on valve (Figure 2, Item 15).
7. Install clamp (Figure 2, Item 10) on cylinder (Figure 2, Item 11) with two new lockwashers (Figure 2, Item 9) and wing nuts (Figure 2, Item 8).
8. Position tube (Figure 2, Item 2) on vehicle and connect tube to connector (Figure 2, Item 16). Tighten nut (Figure 2, Item 7).
9. At engine intake manifold, install washer (Figure 2, Item 5), adapter (Figure 2, Item 4), and spray nozzle (Figure 2, Item 3).
10. Connect tube (Figure 2, Item 2) to spray nozzle (Figure 2, Item 3). Tighten nut (Figure 2, Item 1).
11. In engine compartment, install two clamps (Figure 2, Item 6) on tube (Figure 2, Item 2).

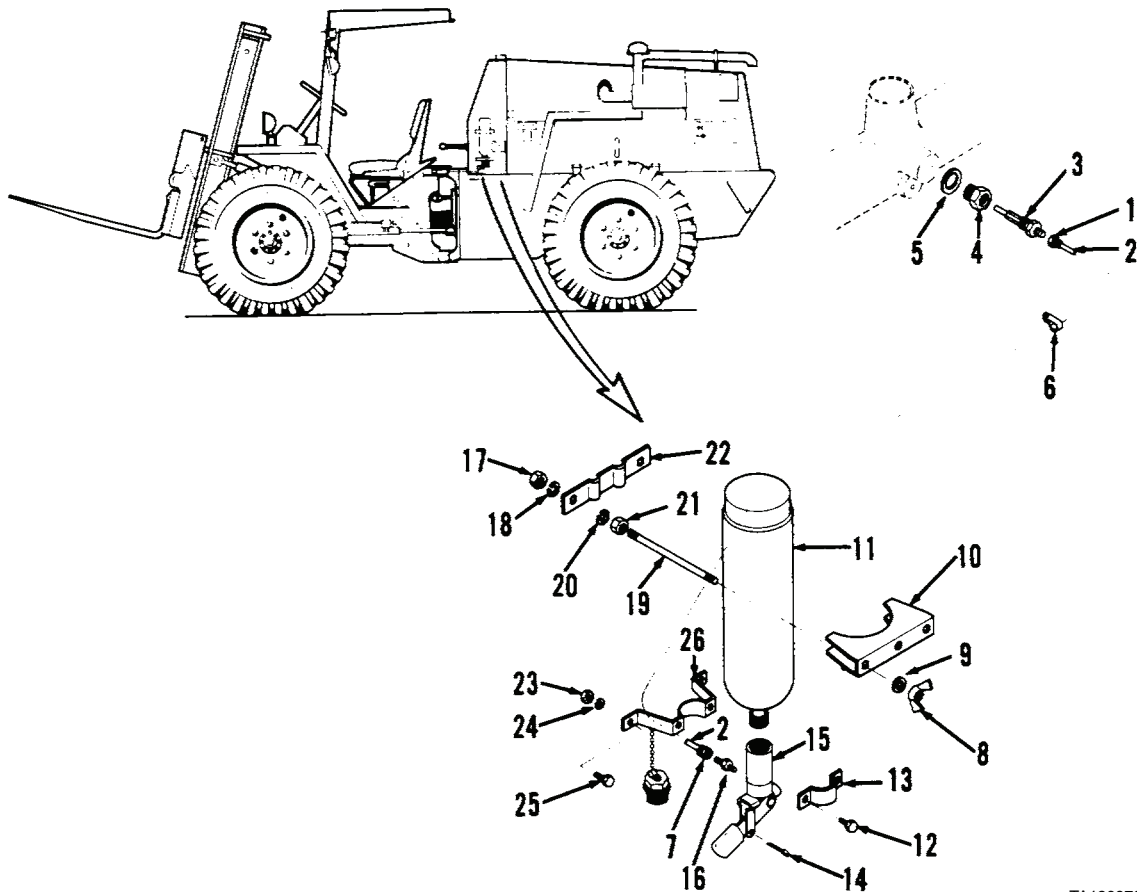

**Figure 2. Quick Start Kit.**

TA126878

**END OF TASK**

**END OF WORK PACKAGE**

---

## ORGANIZATIONAL MAINTENANCE INSTRUCTIONS

### ACCELERATOR AND THROTTLE CONTROL MAINTENANCE (MODEL 207)

Removal, Cleaning, Inspection, Installation, Adjustment

---

#### INITIAL SETUP

##### Maintenance Level

Organizational

##### Tools and Special Tools

Tool kit, general mechanic's (Item 15, WP 0309)

Shop equipment, common no. 1 (Item 2, WP 0309)

##### Materials/Parts

Cleaning compound, solvent (Item 10, WP 0310)

##### Materials/Parts - Continued

Diesel fuel, arctic (Item 14, WP 0310)

Diesel fuel, DF-2 (Item 15, WP 0310)

Rag, wiping (Item 26, WP 0310)

Lockwasher (13)

##### Equipment Condition

Left side panel removed (WP 0179)

---

**REMOVAL**

1. At fuel injection pump, remove nut (Figure 1, Item 1) and disconnect ball joint (Figure 1, Item 2) of accelerator cable (Figure 1, Item 8) from throttle lever of fuel injection pump.
2. Remove two nuts (Figure 1, Item 3), lockwashers (Figure 1, Item 4), washers (Figure 1, Item 5), capscrews (Figure 1, Item 6), clamp (Figure 1, Item 7), and spacer (Figure 1, Item 9) from bracket (Figure 1, Item 13). Discard lockwashers.
3. Disengage accelerator cable (Figure 1, Item 8) from clamp (Figure 1, Item 7).
4. Remove four nuts (Figure 1, Item 10), lockwashers (Figure 1, Item 11), capscrews (Figure 1, Item 12), and bracket (Figure 1, Item 13) from vehicle. Discard lockwashers.
5. At floor of engine compartment, remove nut (Figure 1, Item 14), lockwasher (Figure 1, Item 15), screw (Figure 1, Item 16), and clamp (Figure 1, Item 17) from accelerator cable (Figure 1, Item 8). Discard lockwasher.
6. Remove nut (Figure 1, Item 18), lockwasher (Figure 1, Item 19), capscrew (Figure 1, Item 20), and clamp (Figure 1, Item 21) from accelerator cable (Figure 1, Item 8). Discard lockwasher.
7. At bottom of front floorplate, remove throttle return spring (Figure 1, Item 22).
8. At top of front floorplate, remove nut (Figure 1, Item 23), washer (Figure 1, Item 24), and capscrew (Figure 1, Item 25).
9. At underside of operator's compartment, remove nut (Figure 1, Item 26) and lockwasher (Figure 1, Item 27) and disconnect ball joint (Figure 1, Item 28) of accelerator cable (Figure 1, Item 8) from accelerator pedal (Figure 1, Item 40). Discard lockwasher.
10. Remove two nuts (Figure 1, Item 30), lockwashers (Figure 1, Item 31), capscrews (Figure 1, Item 32), clamp (Figure 1, Item 33), and spacer (34) from accelerator cable (Figure 1, Item 8). Discard lockwashers.
11. Remove accelerator cable (Figure 1, Item 8) from vehicle.
12. At accelerator pedal (Figure 1, Item 40), remove two nuts (Figure 1, Item 35), lockwashers (Figure 1, Item 36), washers (Figure 1, Item 37), capscrews (Figure 1, Item 38), and two pivot bases (Figure 1, Item 39). Discard lockwashers.
13. Remove accelerator pedal (Figure 1, Item 40) from vehicle.
14. Remove ball joint (Figure 1, Item 2), ball joint (Figure 1, Item 28), and two nuts (Figure 1, Item 29) from accelerator cable (Figure 1, Item 8).

**END OF TASK****CLEANING****WARNING**

DO NOT clean using diesel fuel while smoking or near fire, flames, or sparks. Fuel may ignite, causing damage to machine and injury or death to personnel.

1. Clean accelerator cable (Figure 1, Item 8) with clean diesel fuel. Dry thoroughly.

**WARNING**

Solvent cleaning compound MIL-PRF-680 Type III is an environmentally compliant and low toxic material. However, it may be irritating to the eyes and skin. Use protective gloves and goggles. Use in well-ventilated areas. Keep away from open flames and other sources of ignition. Failure to do so may result in injury or death to personnel.

2. Clean all other parts with solvent cleaning compound. Dry thoroughly.

**END OF TASK**



**INSPECTION**

1. Inspect accelerator cable (Figure 1, Item 8). Replace if cracked, worn, or threads are damaged.
2. Inspect throttle return spring (Figure 1, Item 22). Replace if damaged or permanently stretched.
3. Inspect all other parts. Replace if damaged, worn, or threads are damaged.

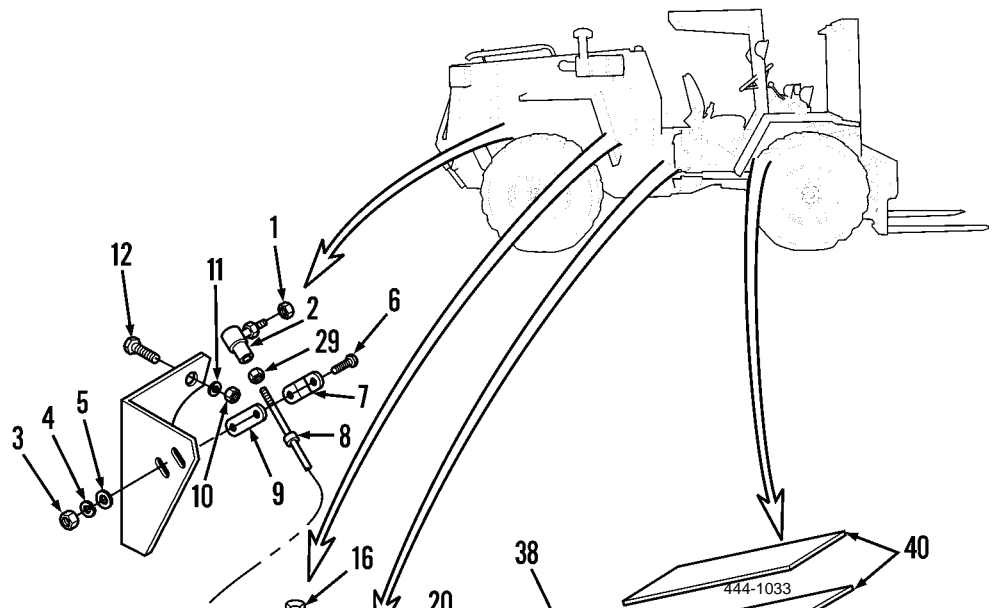

Figure 1. Accelerator and Throttle Control.

END OF TASK

## INSTALLATION

1. Position two nuts (Figure 2, Item 29), ball joint (Figure 2, Item 28), and ball joint (Figure 2, Item 2) on accelerator cable (Figure 2, Item 8).
2. At front floorplate, position accelerator pedal (Figure 2, Item 40) on vehicle.
3. Install accelerator pedal (Figure 2, Item 40) with two pivot bases (Figure 2, Item 39), capscrews (Figure 2, Item 38), washers (Figure 2, Item 37), new lockwashers (Figure 2, Item 36), and nuts (Figure 2, Item 35).
4. Position accelerator cable (Figure 2, Item 8) on vehicle.
5. Install spacer (Figure 2, Item 34), clamp (Figure 2, Item 33), two capscrews (Figure 2, Item 32), new lockwashers (Figure 2, Item 31), and nuts (Figure 2, Item 3) on accelerator cable (Figure 2, Item 8).
6. At underside of operator's compartment, connect ball joint (Figure 2, Item 28) of accelerator cable (Figure 2, Item 8) to accelerator pedal (Figure 2, Item 40) with new lockwasher (Figure 2, Item 27) and nut (Figure 2, Item 26).
7. At top of front floorplate, install capscrew (Figure 2, Item 25), washer (Figure 2, Item 24), and nut (Figure 2, Item 23). Adjust position of capscrew so top of capscrew head projects 1 in. (25 mm) from top of floorplate.
8. At bottom of front floorplate, install throttle return spring (Figure 2, Item 22) on spring attachment plate and accelerator pedal (Figure 2, Item 40).
9. Install clamp (Figure 2, Item 21), capscrew (Figure 2, Item 20), new lockwasher (Figure 2, Item 19), and nut (Figure 2, Item 18) on accelerator cable (Figure 2, Item 8).
10. At floor of engine compartment, install clamp (Figure 2, Item 17), capscrew (Figure 2, Item 16), new lockwasher (Figure 2, Item 15), and nut (Figure 2, Item 14) on accelerator cable (Figure 2, Item 8).
11. Install bracket (Figure 2, Item 13) on vehicle with four capscrews (Figure 2, Item 12), new lockwashers (Figure 2, Item 11), and nuts (Figure 2, Item 10).
12. Position clamp (Figure 2, Item 7) on accelerator cable (Figure 2, Item 8).
13. Install spacer (Figure 2, Item 9), clamp (Figure 2, Item 7), two capscrews (Figure 2, Item 6), washers (Figure 2, Item 5), new lockwashers (Figure 2, Item 4), and nuts (Figure 2, Item 3) on bracket (Figure 2, Item 13).
14. At fuel injection pump, connect ball joint (Figure 2, Item 2) of accelerator cable (Figure 2, Item 8) to throttle lever of fuel injection pump with nut (Figure 2, Item 1).

## END OF TASK

## ADJUSTMENT

1. At fuel injection pump, remove nut (Figure 2, Item 1) and disconnect ball joint (Figure 2, Item 2) of accelerator cable (Figure 2, Item 8) from throttle lever of fuel injection pump.
2. Adjust for less slack in accelerator cable (Figure 2, Item 8) by threading nut (Figure 2, Item 29) farther onto cable. Increase slack by threading nut out of accelerator cable.
3. When all slack is removed from accelerator cable (Figure 2, Item 8), tighten nut (Figure 2, Item 29).
4. Without needing to move throttle lever of fuel injection pump, connect ball joint (Figure 2, Item 2) to throttle lever and install nut (Figure 2, Item 1).

## NOTE

If there is still too much or not enough slack in accelerator cable, perform steps 5 through 8.

5. At other end of accelerator cable (Figure 2, Item 8), remove nut (Figure 2, Item 26), lockwasher (Figure 2, Item 27), and disconnect ball joint (Figure 2, Item 28) from accelerator pedal (Figure 2, Item 40).
6. Adjust for less slack in accelerator cable (Figure 2, Item 8) by threading nut (Figure 2, Item 29) farther onto cable. Increase slack by threading nut out of accelerator cable.
7. When all slack is removed from accelerator cable (Figure 2, Item 8), tighten nut (Figure 2, Item 29).
8. Without needing to move accelerator pedal (Figure 2, Item 40), install ball joint (Figure 2, Item 28) on accelerator pedal and install new lockwasher (Figure 2, Item 27) and nut (Figure 2, Item 26).

ADJUSTMENT - CONTINUED

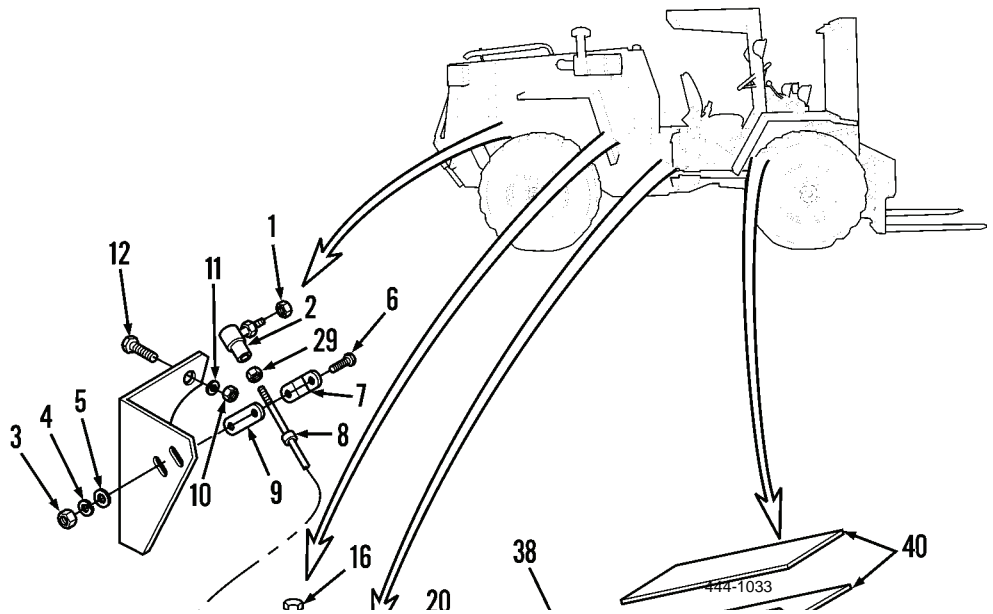

Figure 2. Accelerator and Throttle Control.

END OF TASK

END OF WORK PACKAGE



---

## ORGANIZATIONAL MAINTENANCE INSTRUCTIONS

### ACCELERATOR AND THROTTLE CONTROL MAINTENANCE (MODEL 4-390)

Removal, Cleaning, Inspection, Installation, Adjustment

---

#### INITIAL SETUP

##### Maintenance Level

Organizational

##### Tools and Special Tools

Tool kit, general mechanic's (Item 15, WP 0309)

Shop equipment, common no. 1 (Item 2, WP 0309)

##### Materials/Parts

Cleaning compound, solvent (Item 10, WP 0310)

##### Materials/Parts - Continued

Diesel fuel, arctic (Item 14, WP 0310)

Diesel fuel, DF-2 (Item 15, WP 0310)

Rag, wiping (Item 26, WP 0310)

Locknut

Lockwasher (10)

##### Equipment Condition

Engine OFF

Right side panel removed (WP 0179)

---

**REMOVAL**

1. At right side of engine compartment, remove locknut (Figure 1, Item 1) and lockwasher (Figure 1, Item 2) from ball joint (Figure 1, Item 3). Discard locknut and lockwasher.
2. Disconnect ball joint (Figure 1, Item 3) from fuel injection pump throttle lever.
3. Loosen nut (Figure 1, Item 4) and remove ball joint (Figure 1, Item 3) and nut from end of accelerator cable (Figure 1, Item 5).
4. Remove two nuts (Figure 1, Item 6), lockwashers (Figure 1, Item 7), washers (Figure 1, Item 8), and capscrews (Figure 1, Item 9) from accelerator cable bracket (Figure 1, Item 12). Discard lockwashers.
5. Remove clamp (Figure 1, Item 10), accelerator cable (Figure 1, Item 5), and spacer (Figure 1, Item 11) from accelerator cable bracket (Figure 1, Item 12).
6. Remove two nuts (Figure 1, Item 13), four washers (Figure 1, Item 14), two capscrews (Figure 1, Item 15), and accelerator cable bracket (Figure 1, Item 12) from engine bracket (Figure 1, Item 16).
7. Remove bolt (Figure 1, Item 17), lockwasher (Figure 1, Item 18), and engine bracket (Figure 1, Item 16) from engine cylinder block. Discard lockwasher.
8. At bottom of front floor plate, remove throttle return spring (Figure 1, Item 19).
9. At top of front floor plate, note position of capscrew (Figure 1, Item 21).
10. Loosen nut (Figure 1, Item 20) and remove capscrew (Figure 1, Item 21) and nut from front floor plate.
11. At bottom of operator's compartment, remove nut (Figure 1, Item 22) and lockwasher (Figure 1, Item 23). Discard lockwasher.
12. Disconnect ball joint (Figure 1, Item 24) from accelerator pedal (Figure 1, Item 25).
13. Loosen nut (Figure 1, Item 26) and remove ball joint (Figure 1, Item 24) and nut from end of accelerator cable (Figure 1, Item 5).
14. Remove two nuts (Figure 1, Item 27), lockwashers (Figure 1, Item 28), capscrews (Figure 1, Item 29), clamp (Figure 1, Item 30), and spacer (Figure 1, Item 21) from accelerator cable (Figure 1, Item 5). Discard lockwashers.
15. At center of vehicle, remove nut (Figure 1, Item 32), lockwasher (Figure 1, Item 33), capscrew (Figure 1, Item 34), and clamp (Figure 1, Item 35) from accelerator cable (Figure 1, Item 5). Discard lockwasher.
16. Remove accelerator cable (Figure 1, Item 5) from vehicle.
17. At bottom of operator's compartment, remove two nuts (Figure 1, Item 36), lockwashers (Figure 1, Item 37), washers (Figure 1, Item 38), capscrews (Figure 1, Item 39), and two accelerator pivot bases (Figure 1, Item 40). Discard lockwashers.
18. Remove accelerator pedal (Figure 1, Item 25) from vehicle.

REMOVAL - CONTINUED

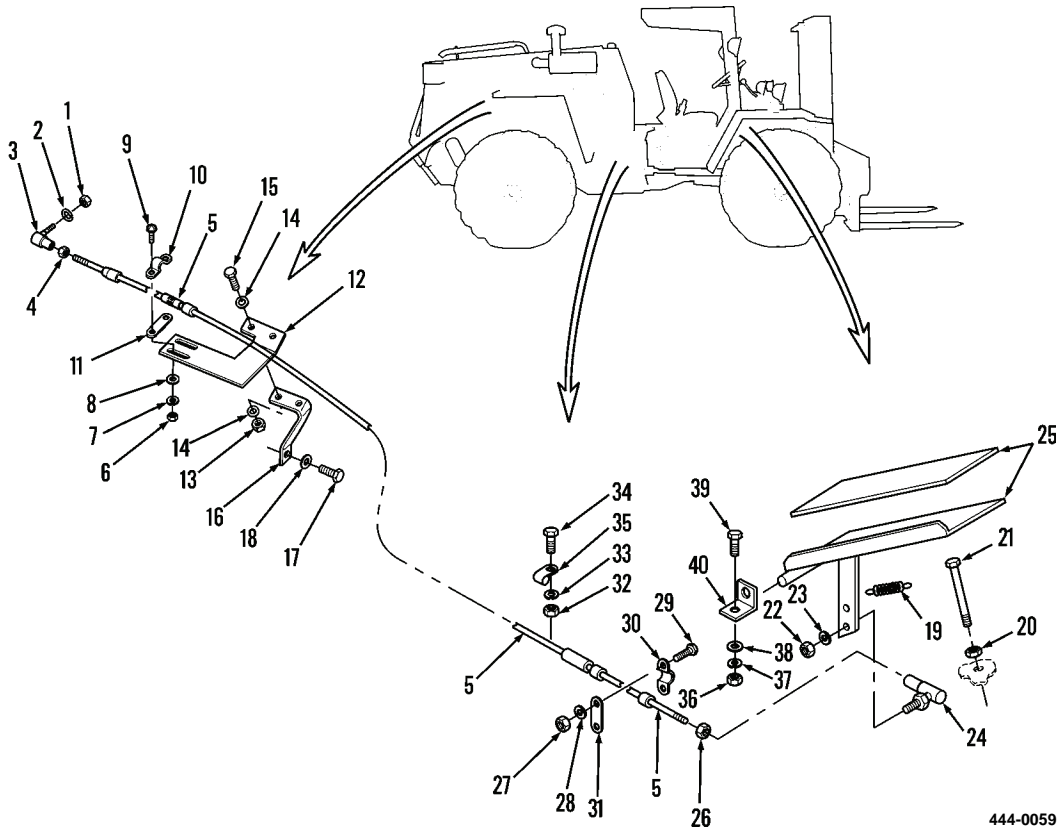

Figure 1. Accelerator and Throttle Control.

END OF TASK

CLEANING



WARNING

DO NOT clean using diesel fuel while smoking or near fire, flames, or sparks. Fuel may ignite, causing damage to machine and injury or death to personnel.

1. Clean accelerator cable (Figure 1, Item 5) with clean diesel fuel. Dry thoroughly.



WARNING



Solvent cleaning compound MIL-PRF-680 Type III is an environmentally compliant and low toxic material. However, it may be irritating to the eyes and skin. Use protective gloves and goggles. Use in well-ventilated areas. Keep away from open flames and other sources of ignition. Failure to do so may result in injury or death to personnel.

2. Clean all other parts with solvent cleaning compound. Dry thoroughly.

END OF TASK

**INSPECTION**

1. Inspect accelerator cable. Replace if cracked, worn, or threads are damaged.
2. Inspect throttle return spring. Replace if deformed or permanently set.
3. Inspect all other parts. Replace if cracked, worn, or threads are damaged.

**END OF TASK****INSTALLATION**

1. Position accelerator pedal (Figure 2, Item 25) on floor of operator's compartment.
2. Position two accelerator pivot bases (Figure 2, Item 40) with one on each end of accelerator pedal (Figure 2, Item 25).
3. Install two capscrews (Figure 2, Item 39), washers (Figure 2, Item 38), new lockwashers (Figure 2, Item 37), and nuts (Figure 2, Item 36) on accelerator pivot bases (Figure 2, Item 40).
4. Position accelerator cable (Figure 2, Item 5) in vehicle.
5. At center of vehicle, install clamp (Figure 2, Item 35), capscrew (Figure 2, Item 34), new lockwasher (Figure 2, Item 33), and nut (Figure 2, Item 32) on accelerator cable (Figure 2, Item 5).
6. At bottom of operator's compartment, install spacer (Figure 2, Item 31) and clamp (Figure 2, Item 30) on accelerator cable (Figure 2, Item 5) with two capscrews (Figure 2, Item 29), new lockwashers (Figure 2, Item 28), and nuts (Figure 2, Item 27).
7. Install nut (Figure 2, Item 26) and ball joint (Figure 2, Item 24) on end of accelerator cable (Figure 2, Item 5). Tighten nut against ball joint.
8. Connect ball joint (Figure 2, Item 24) to accelerator pedal (Figure 2, Item 25) with new lockwasher (Figure 2, Item 23) and nut (Figure 2, Item 22).
9. At top of front floor plate, install nut (Figure 2, Item 20) and capscrew (Figure 2, Item 21) at position noted and tighten nut.
10. At bottom of front floor plate, install throttle return spring (Figure 2, Item 19). Hook one end of spring on accelerator pedal (Figure 2, Item 25) and other end to bracket of floor plate.
11. Install engine bracket (Figure 2, Item 16) on engine cylinder block with new lockwasher (Figure 2, Item 18) and bolt (Figure 2, Item 17).
12. Install accelerator cable bracket (Figure 2, Item 12) on engine bracket (Figure 2, Item 16) with two capscrews (Figure 2, Item 15), four washers (Figure 2, Item 14), and two nuts (Figure 2, Item 13).
13. Install spacer (Figure 2, Item 11), accelerator cable (Figure 2, Item 5), and clamp (Figure 2, Item 10) on accelerator cable bracket (Figure 2, Item 12) with two capscrews (Figure 2, Item 9), washers (Figure 2, Item 8), new lockwashers (Figure 2, Item 7), and nuts (Figure 2, Item 6).
14. Install nut (Figure 2, Item 4) and ball joint (Figure 2, Item 3) on end of accelerator cable (Figure 2, Item 5). Tighten nut against ball joint.
15. Connect ball joint (Figure 2, Item 3) to fuel injection pump throttle lever with new lockwasher (Figure 2, Item 2) and new locknut (Figure 2, Item 1).



INSTALLATION - CONTINUED

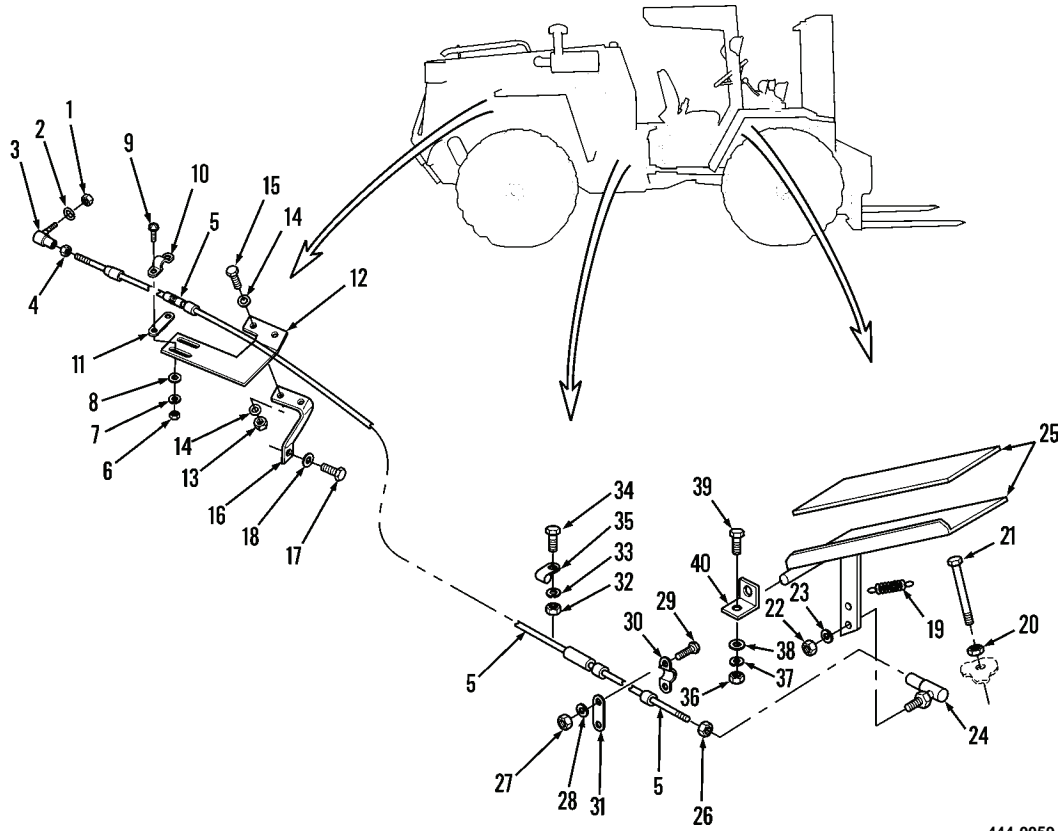

444-0059

Figure 2. Accelerator and Throttle Control.

END OF TASK

**ADJUSTMENT****NOTE**

Adjust for minimum slack in accelerator cable.

1. In engine compartment, remove locknut (Figure 3, Item 1) and lockwasher (Figure 3, Item 2) from ball joint (Figure 3, Item 3). Discard lockwasher and locknut.
2. Disconnect ball joint (Figure 3, Item 3) from fuel injection pump throttle lever.
3. Loosen nut (Figure 3, Item 4) and adjust ball joint (Figure 3, Item 3). Thread nut in for less slack. Thread nut out for more slack.
4. Tighten nut (Figure 3, Item 4) against ball joint (Figure 3, Item 3).

**NOTE**

When connecting ball joint to fuel injection pump throttle lever, be sure you do not move throttle lever.

5. Connect ball joint (Figure 3, Item 3) to fuel injection pump throttle lever.
6. Install new lockwasher (Figure 3, Item 2) and new locknut (Figure 3, Item 1) on ball joint (Figure 3, Item 3).

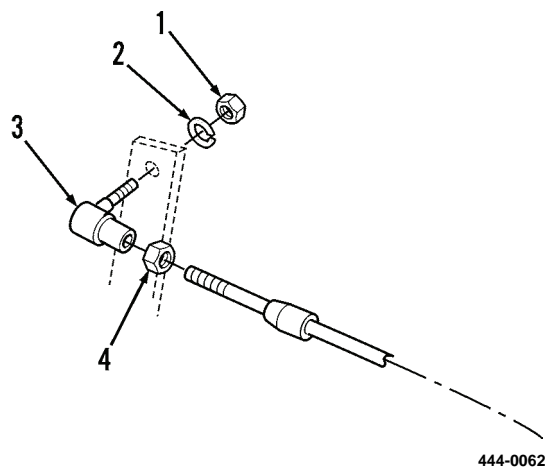

**Figure 3. Accelerator Cable Assembly.**

**ADJUSTMENT - CONTINUED****NOTE**

If there is still too much, or not enough, slack in accelerator cable, perform steps 7 through 12.

7. At bottom of front floor plate, remove nut (Figure 4, Item 22) and lockwasher (Figure 4, Item 23) from ball joint (Figure 4, Item 24). Discard lockwasher.
8. Disconnect ball joint (Figure 4, Item 24) from accelerator pedal (Figure 4, Item 25).
9. Loosen nut (Figure 4, Item 26) and adjust ball joint (Figure 4, Item 24). Thread nut in for less slack. Thread nut out for more slack.
10. Tighten nut (Figure 4, Item 26) against ball joint (Figure 4, Item 24).

**NOTE**

When connecting ball joint to accelerator pedal, be sure you do not move accelerator pedal.

11. Connect ball joint (Figure 4, Item 24) to accelerator pedal (Figure 4, Item 25).
12. Install new lockwasher (Figure 4, Item 23) and nut (Figure 4, Item 22) on ball joint (Figure 4, Item 24).

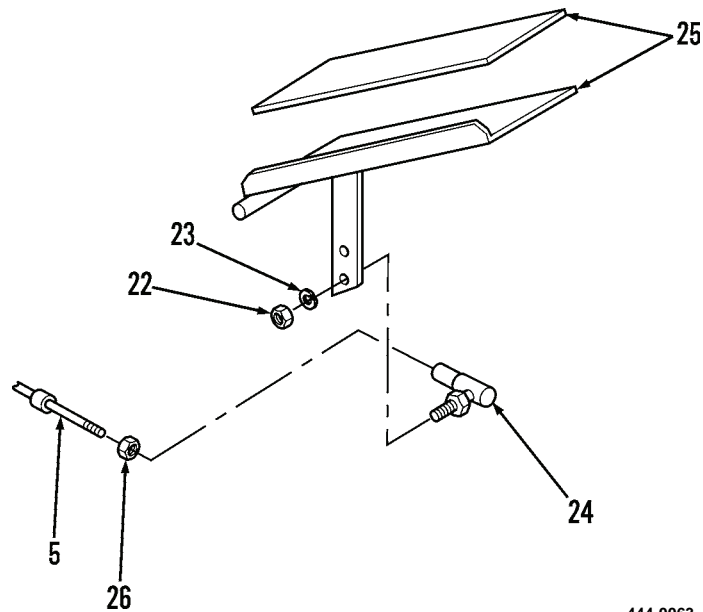

444-0063

**Figure 4. Accelerator Pedal Assembly.****END OF TASK****END OF WORK PACKAGE**



---

## ORGANIZATIONAL MAINTENANCE INSTRUCTIONS

### SPARK ARRESTING MUFFLER AND EXHAUST PIPE MAINTENANCE (MODEL 207)

Periodic Cleaning, Removal, Cleaning, Inspection, Installation

---

#### INITIAL SETUP

##### Maintenance Level

Organizational

##### Tools and Special Tools

Tool kit, general mechanic's (Item 15, WP 0309)

Shop equipment, common no. 1 (Item 2, WP 0309)

Tarpaulin

Wood

##### Materials/Parts

Brush, wire (Item 8, WP 0310)

Cleaning compound, solvent (Item 10, WP 0310)

##### Materials/Parts - Continued

Gasket

Lockwasher (16)

##### References

WP 0180

##### Equipment Condition

Engine OFF

Parking brake set

Transmission direction selector in (Neutral)  
position

Right side panel removed (WP 0179)

---

---

**PERIODIC CLEANING**

1. Remove exhaust pipe (refer to *Removal* in this work package).
2. Remove top hood (WP 0180).
3. In engine compartment, disconnect wire from terminal of fuel injection pump (Figure 1).
4. Remove pipe plug from bottom of spark arresting muffler.

**CAUTION**

Make sure tarpaulin does not interfere with fan blades.

5. Place a tarpaulin over engine to protect engine from soot.
6. Place ignition switch in ON position.
7. At top of vehicle, hold a flat piece of wood against outlet of spark arresting muffler.

**WARNING**

Make sure parking brake is applied and transmission direction selector is in N position to prevent injury to personnel.

8. Press start button and hold for 30 seconds. As engine cranks, loosened soot will be expelled through pipe plug hole of muffler.
9. Release start button and place ignition switch in OFF position.
10. Connect wire to terminal of fuel injection pump.
11. Install pipe plug on bottom of spark arresting muffler.
12. Install top hood (WP 0180).
13. Install exhaust pipe (refer to *Installation* in this work package).

PERIODIC CLEANING - CONTINUED

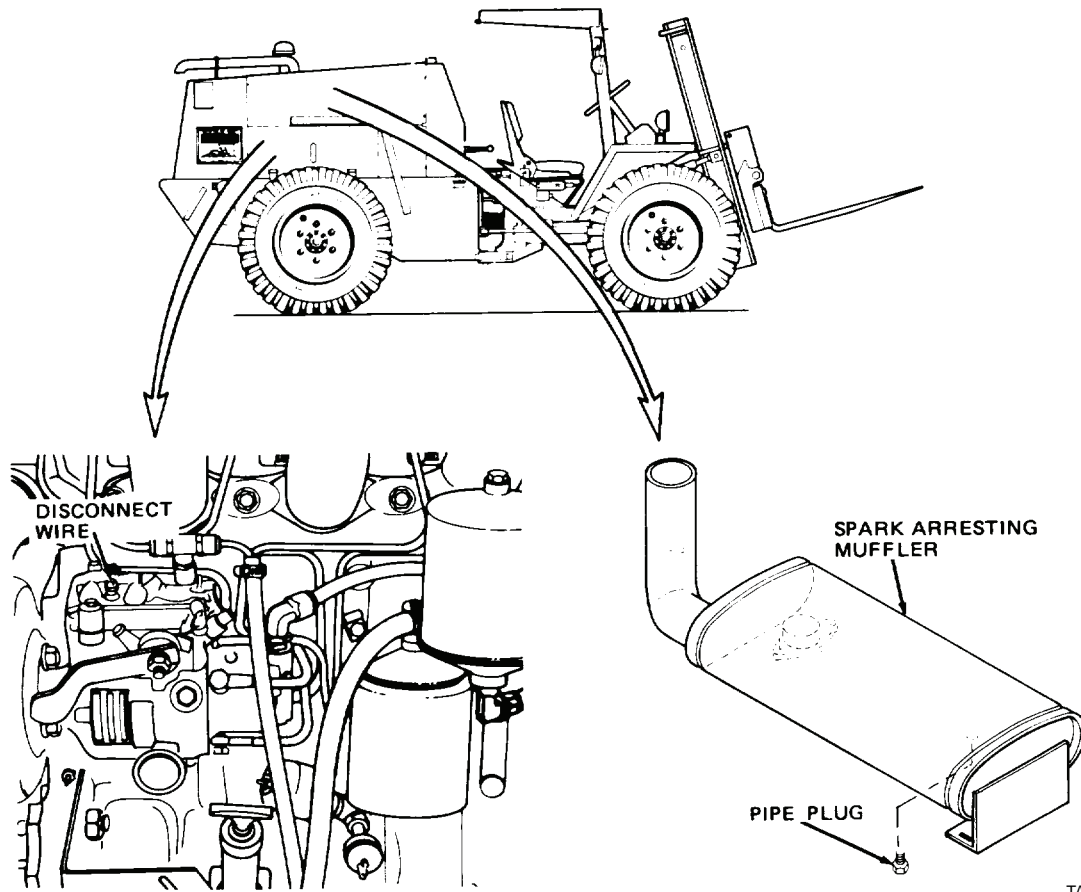

TA126880

Figure 1. Spark Arresting Muffler and Fuel Injection Pump.

END OF TASK

**REMOVAL****NOTE**

Perform steps 1 and 2 to remove exhaust pipe.

1. At top of vehicle, remove four nuts (Figure 2, Item 1), lockwashers (Figure 2, Item 2), two clamps (Figure 2, Item 3), and two U-bolts (Figure 2, Item 4). Discard lockwashers.
2. Remove exhaust pipe (Figure 2, Item 5) from vehicle.
3. Remove top hood (WP 0180).
4. At top of radiator shroud, remove four nuts (Figure 2, Item 6), lockwashers (Figure 2, Item 7), capscrews (Figure 2, Item 8), bracket (Figure 2, Item 9), and support (Figure 2, Item 10). Discard lockwashers.
5. Remove two nuts (Figure 2, Item 11), lockwashers (Figure 2, Item 12), capscrews (Figure 2, Item 13), and bracket (Figure 2, Item 14). Discard lockwashers.
6. At exhaust manifold, remove two nuts (Figure 2, Item 15), lockwashers (Figure 2, Item 16), and capscrews (Figure 2, Item 17). Discard lockwashers.
7. Remove two nuts (Figure 2, Item 18), lockwashers (Figure 2, Item 19), washers (Figure 2, Item 20), washers (Figure 2, Item 22), and capscrews (Figure 2, Item 21). Discard lockwashers.
8. Remove muffler (Figure 2, Item 23) and gasket (Figure 2, Item 24). Discard gasket.
9. Remove two capscrews (Figure 2, Item 25), lockwashers (Figure 2, Item 26), and bracket (Figure 2, Item 27) from engine. Discard lockwashers.

**END OF TASK****CLEANING****WARNING**

- Solvent cleaning compound MIL-PRF-680 Type III is an environmentally compliant and low toxic material. However, it may be irritating to the eyes and skin. Use protective gloves and goggles. Use in well-ventilated areas. Keep away from open flames and other sources of ignition. Failure to do so may result in injury or death to personnel.
- Particles blown by compressed air are hazardous. DO NOT exceed 15 PSI (103 kPa) nozzle pressure when drying parts with compressed air. DO NOT direct compressed air against human skin. Make sure air stream is directed away from user and other personnel in the area. To prevent injury, user must wear protective goggles or face shield. Failure to follow this warning may result in injury to personnel.

Remove any rust with stiff wire brush and clean all parts with solvent cleaning compound. Dry thoroughly with compressed air.

**END OF TASK****INSPECTION**

Inspect all parts. Replace if cracked, worn, damaged, dented or threads are damaged.



INSPECTION - CONTINUED

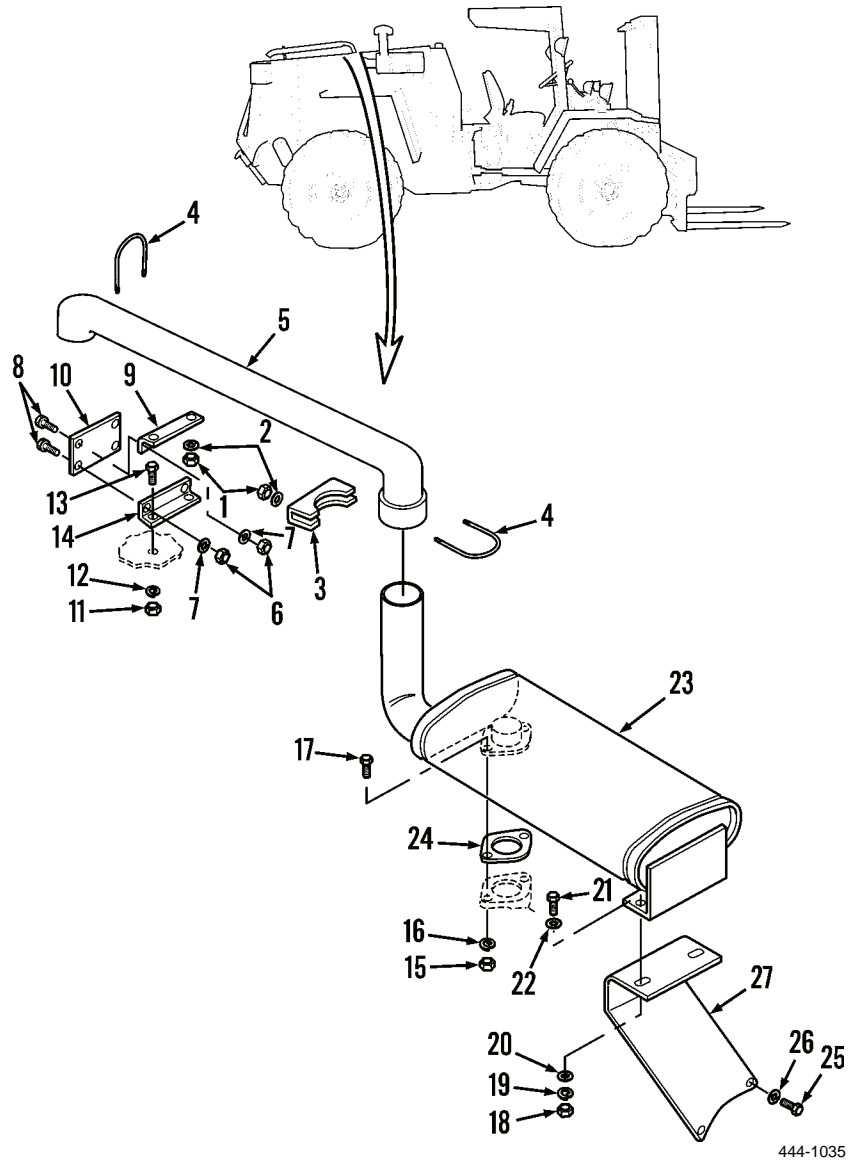

Figure 2. Spark Arresting Muffler and Exhaust Pipe Assembly.

END OF TASK

---

**INSTALLATION**

1. Install bracket (Figure 3, Item 27) on engine with two new lockwashers (Figure 3, Item 26) and capscrews (Figure 3, Item 25).
2. Position new gasket (Figure 3, Item 24) and muffler (Figure 3, Item 23) on exhaust manifold.
3. Install two capscrews (Figure 3, Item 21), washers (Figure 3, Item 22), washers (Figure 3, Item 20), new lockwashers (Figure 3, Item 19), and nuts (Figure 3, Item 18).
4. At exhaust manifold, install two capscrews (Figure 3, Item 17), new lockwashers (Figure 3, Item 16), and nuts (Figure 3, Item 15).
5. At top of radiator shroud, install bracket (Figure 3, Item 14) with two capscrews (Figure 3, Item 13), new lockwashers (Figure 3, Item 12), and nuts (Figure 3, Item 11).
6. Install support (Figure 3, Item 10) and bracket (Figure 3, Item 9) with four capscrews (Figure 3, Item 8), new lockwashers (Figure 3, Item 7), and nuts (Figure 3, Item 6).
7. Install top hood (WP 0180).

**NOTE**

Perform steps 8 and 9 to install exhaust pipe.

8. Position exhaust pipe (Figure 3, Item 5) on vehicle.
9. At top of vehicle, install two U-bolts (Figure 3, Item 4), clamps (Figure 3, Item 3), four new lockwashers (Figure 3, Item 2), and nuts (Figure 3, Item 1).

INSTALLATION - CONTINUED

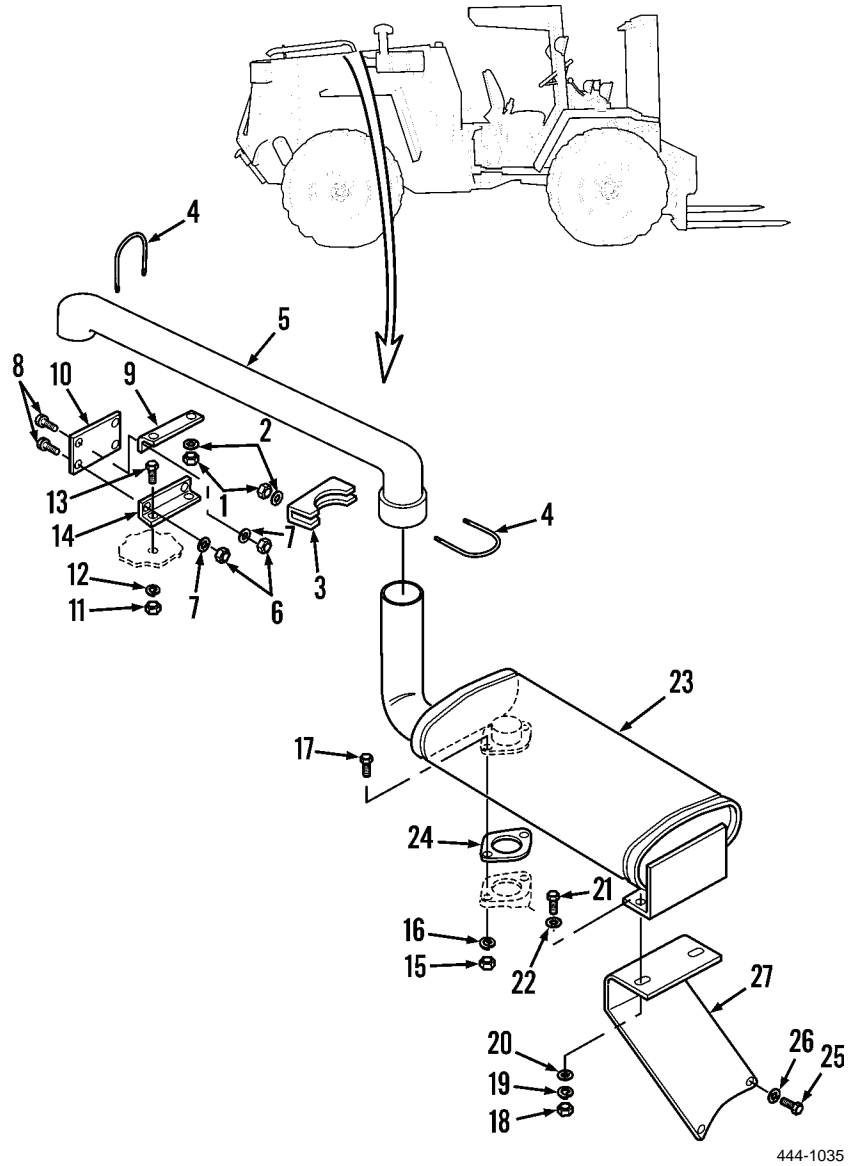

444-1035

Figure 3. Spark Arresting Muffler and Exhaust Pipe Assembly.

END OF TASK

END OF WORK PACKAGE



---

## ORGANIZATIONAL MAINTENANCE INSTRUCTIONS

### SPARK ARRESTING MUFFLER AND EXHAUST PIPE MAINTENANCE (MODEL 4-390)

#### Removal, Cleaning, Inspection, Installation/Replacement

---

#### INITIAL SETUP

**Maintenance Level**

Organizational

**Tools and Special Tools**

Tool kit, general mechanic's (Item 15, WP 0309)

Shop equipment, common no. 1 (Item 2, WP 0309)

**Materials/Parts**

Brush, wire (Item 8, WP 0310)

Cleaning compound, solvent (Item 10, WP 0310)

**Materials/Parts - Continued**

Rag, wiping (Item 26, WP 0310)

Gasket

Lockwasher (12)

**References**

WP 0181

**Equipment Condition**

Engine OFF

Parking brake applied

---

---

**REMOVAL**

1. Remove four nuts (Figure 1, Item 1) from two U-bolts (Figure 1, Item 2) at top rear of vehicle.
2. Remove two U-bolts (Figure 1, Item 2) and clamps (Figure 1, Item 3) from exhaust pipe (Figure 1, Item 4).
3. Remove exhaust pipe (Figure 1, Item 4) from vehicle.
4. Remove top hood (WP 0181).
5. Remove four nuts (Figure 1, Item 5), lockwashers (Figure 1, Item 6), and capscrews (Figure 1, Item 7) from top of radiator shroud. Discard lockwashers.
6. Remove bracket (Figure 1, Item 8) and rubber support (Figure 1, Item 9) from bracket (Figure 1, Item 10).
7. Remove two nuts (Figure 1, Item 11), lockwashers (Figure 1, Item 12), and capscrews (Figure 1, Item 13) from bracket (Figure 1, Item 10). Discard lockwashers.
8. Remove bracket (Figure 1, Item 10) from top of radiator shroud.
9. Remove bolt (Figure 1, Item 14) and lockwasher (Figure 1, Item 15) from lower end of support bracket (Figure 1, Item 16). Discard lockwasher.
10. Remove nut (Figure 1, Item 17), lockwasher (Figure 1, Item 18), spacer (Figure 1, Item 19), support bracket (Figure 1, Item 16), washer (Figure 1, Item 20), and bolt (Figure 1, Item 21) from muffler (Figure 1, Item 22). Discard lockwasher.
11. Remove two nuts (Figure 1, Item 23), clamp (Figure 1, Item 24), and U-bolt (Figure 1, Item 25) from muffler (Figure 1, Item 22).
12. Remove muffler (Figure 1, Item 22) from vehicle.
13. Remove four capscrews (Figure 1, Item 26) and lockwashers (Figure 1, Item 27) from adapter (Figure 1, Item 28). Discard lockwashers.
14. Remove adapter (Figure 1, Item 28) and gasket (Figure 1, Item 29) from engine exhaust manifold gasket. Discard gasket.

REMOVAL - CONTINUED

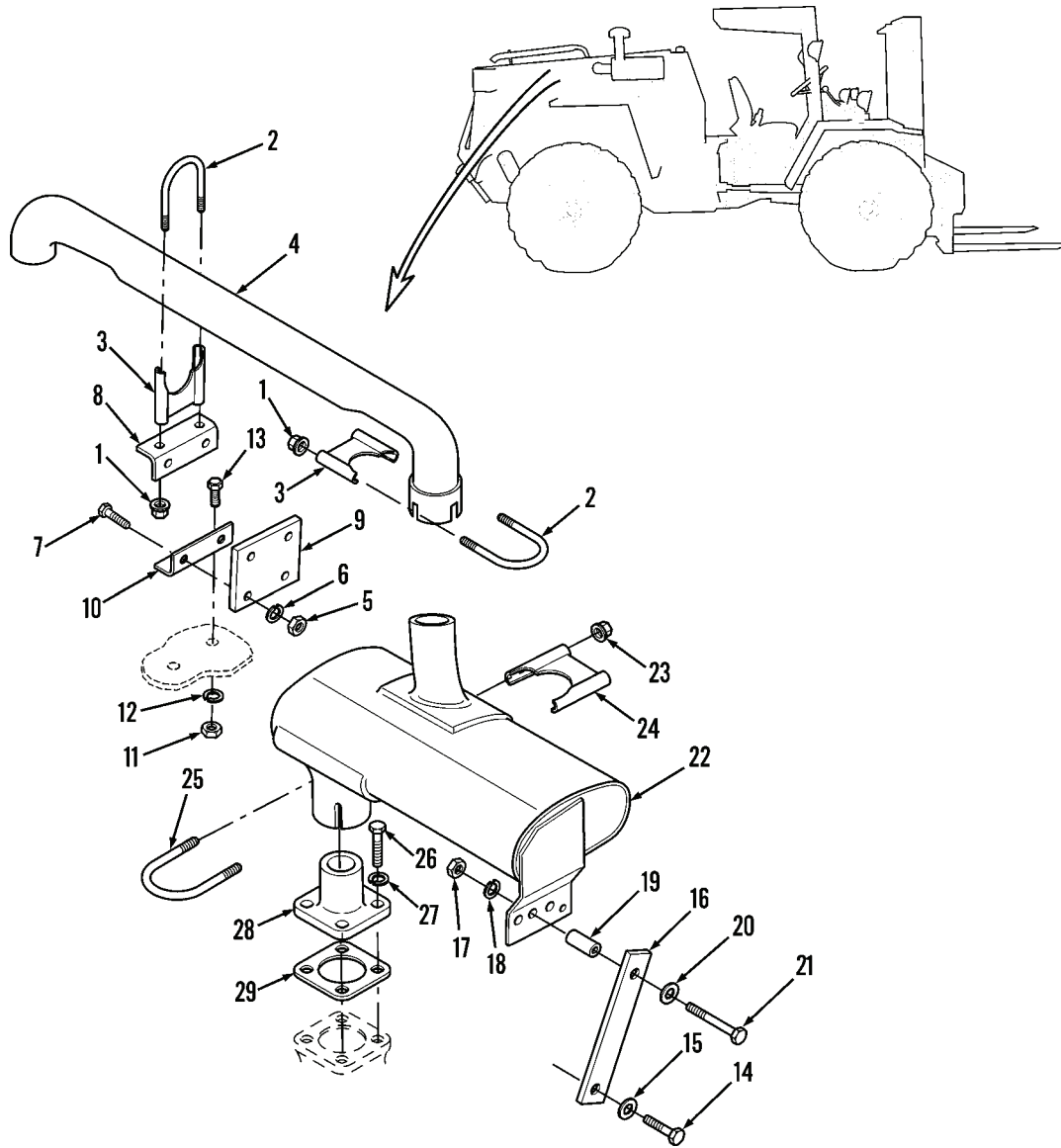

444-0064

Figure 1. Spark Arresting Muffler and Exhaust Pipe Assembly.

END OF TASK

**CLEANING****WARNING**

- Solvent cleaning compound MIL-PRF-680 Type III is an environmentally compliant and low toxic material. However, it may be irritating to the eyes and skin. Use protective gloves and goggles. Use in well-ventilated areas. Keep away from open flames and other sources of ignition. Failure to do so may result in injury or death to personnel.
- Particles blown by compressed air are hazardous. DO NOT exceed 15 PSI (103 kPa) nozzle pressure when drying parts with compressed air. DO NOT direct compressed air against human skin. Make sure air stream is directed away from user and other personnel in the area. To prevent injury, user must wear protective goggles or face shield. Failure to follow this warning may result in injury to personnel.

Use solvent cleaning compound to clean all parts. Dry thoroughly with compressed air. Remove rust with stiff wire brush.

**END OF TASK****INSPECTION**

Inspect all parts. Replace if cracked, damaged, worn, dented, or threads damaged.

**END OF TASK****INSTALLATION/REPLACEMENT**

1. Position new gasket (Figure 2, Item 29) and adapter (Figure 2, Item 28) on engine exhaust manifold and install four new lockwashers (Figure 2, Item 27) and capscrews (Figure 2, Item 26).
2. Install muffler (Figure 2, Item 22) on adapter (Figure 2, Item 28).
3. Install U-bolt (Figure 2, Item 25), clamp (Figure 2, Item 24), and two nuts (Figure 2, Item 23) on muffler (Figure 2, Item 22).
4. Install bolt (Figure 2, Item 21), washer (Figure 2, Item 20), support bracket (Figure 2, Item 16), spacer (Figure 2, Item 19), new lockwasher (Figure 2, Item 18), and nut (Figure 2, Item 17) on muffler (Figure 2, Item 22).
5. Install new lockwasher (Figure 2, Item 15) and bolt (Figure 2, Item 14) on lower end of support bracket (Figure 2, Item 16).
6. Position bracket (Figure 2, Item 10) on top of radiator shroud and install two capscrews (Figure 2, Item 13), new lockwashers (Figure 2, Item 12), and nuts (Figure 2, Item 11).
7. Position rubber support (Figure 2, Item 9) and bracket (Figure 2, Item 8) on bracket (Figure 2, Item 10).
8. Install four capscrews (Figure 2, Item 7), new lockwashers (Figure 2, Item 6), and nuts (Figure 2, Item 5) on bracket (10) and rubber support (Figure 2, Item 9) and tighten nuts.
9. Install top hood (WP 0181).
10. Position exhaust pipe (Figure 2, Item 4) on vehicle and install two clamps (Figure 2, Item 3), U-bolts (Figure 2, Item 2), and four nuts (Figure 2, Item 1).



INSTALLATION/REPLACEMENT - CONTINUED

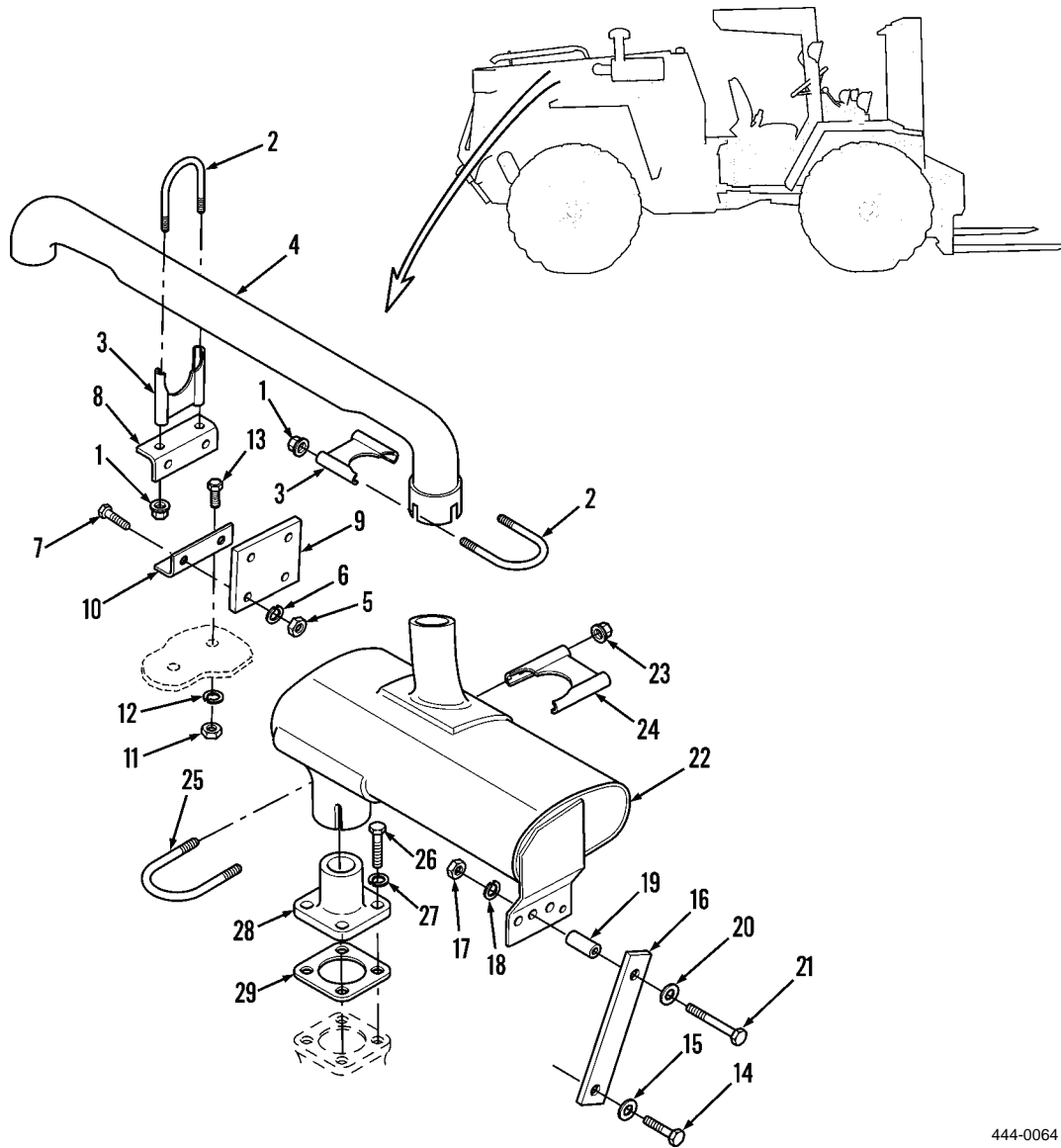

444-0064

Figure 2. Spark Arresting Muffler and Exhaust Pipe Assembly.

END OF TASK

END OF WORK PACKAGE



---

# ORGANIZATIONAL MAINTENANCE INSTRUCTIONS

## RADIATOR SERVICING (MODEL 207)

### Service

---

#### INITIAL SETUP

**Maintenance Level**

Organizational

**Tools and Special Tools**

Tool kit, general mechanic's (Item 15, WP 0309)

Shop equipment, common no. 1 (Item 2, WP 0309)

**Materials/Parts**

Antifreeze (Item 4, WP 0310)

Lockwasher (2)

**Equipment Condition**Left and right side panels removed (WP 0179)

---

**SERVICE**

1. Remove two capscrews, lockwashers, and cover plate from top rear of vehicle (Figure 1). Discard lockwashers.

**WARNING**

Remove radiator cap slowly to release pressure before completely removing when engine is hot. Failure to do so may result in injury to personnel.

2. Remove radiator cap.

**WARNING**

Engine coolant can be very slippery. Immediately wipe up any spills. Failure to follow this warning may result in injury to personnel.

**NOTE**

When servicing this vehicle, performing maintenance, or disposing of engine coolant, consult your unit/local hazardous waste disposal center or safety office for local regulatory guidance. If further information is needed, please contact The Army Environmental Hotline at 1-800-872-3845.

3. Open radiator drain cock and drain coolant; then close drain cock.
4. Remove cylinder block drain plug and drain coolant; then install cylinder block drain plug.

**NOTE**

To flush with water, fill radiator with water and operate engine for 15 minutes. Drain system completely. Close radiator drain cock and reinstall cylinder block drain plug.

5. Fill and flush radiator with clean water.

**WARNING**

Particles blown by compressed air are hazardous. Use a maximum of 30 PSI (207 kPa) when cleaning components. DO NOT direct compressed air against human skin. Failure to follow this warning may result in injury to personnel. Make sure air stream is directed away from user and other personnel in the area. To prevent injury, user must wear protective goggles or face shield.

6. Use compressed air to clean exterior and to remove foreign matter obstructing passage of air through radiator.

**NOTE**

Cooling system capacity is 16 qt (15 L).

7. Use solution of 50 percent water and 50 percent antifreeze and fill cooling system to 2 in. (51 mm) below level of radiator cap opening.
8. Install radiator cap.
9. Operate engine for 15 minutes. Check for coolant leaks at drain plug and drain cock; tighten if necessary.
10. Check coolant level; add coolant if necessary.
11. Remove cap on coolant recovery tank and fill recovery tank half full with solution of 50 percent water and 50 percent antifreeze.
12. Install cap on coolant recovery tank.
13. Position cover plate on radiator shroud.
14. Install two new lockwashers and capscrews and tighten until cover plate is securely mounted.

SERVICE - CONTINUED

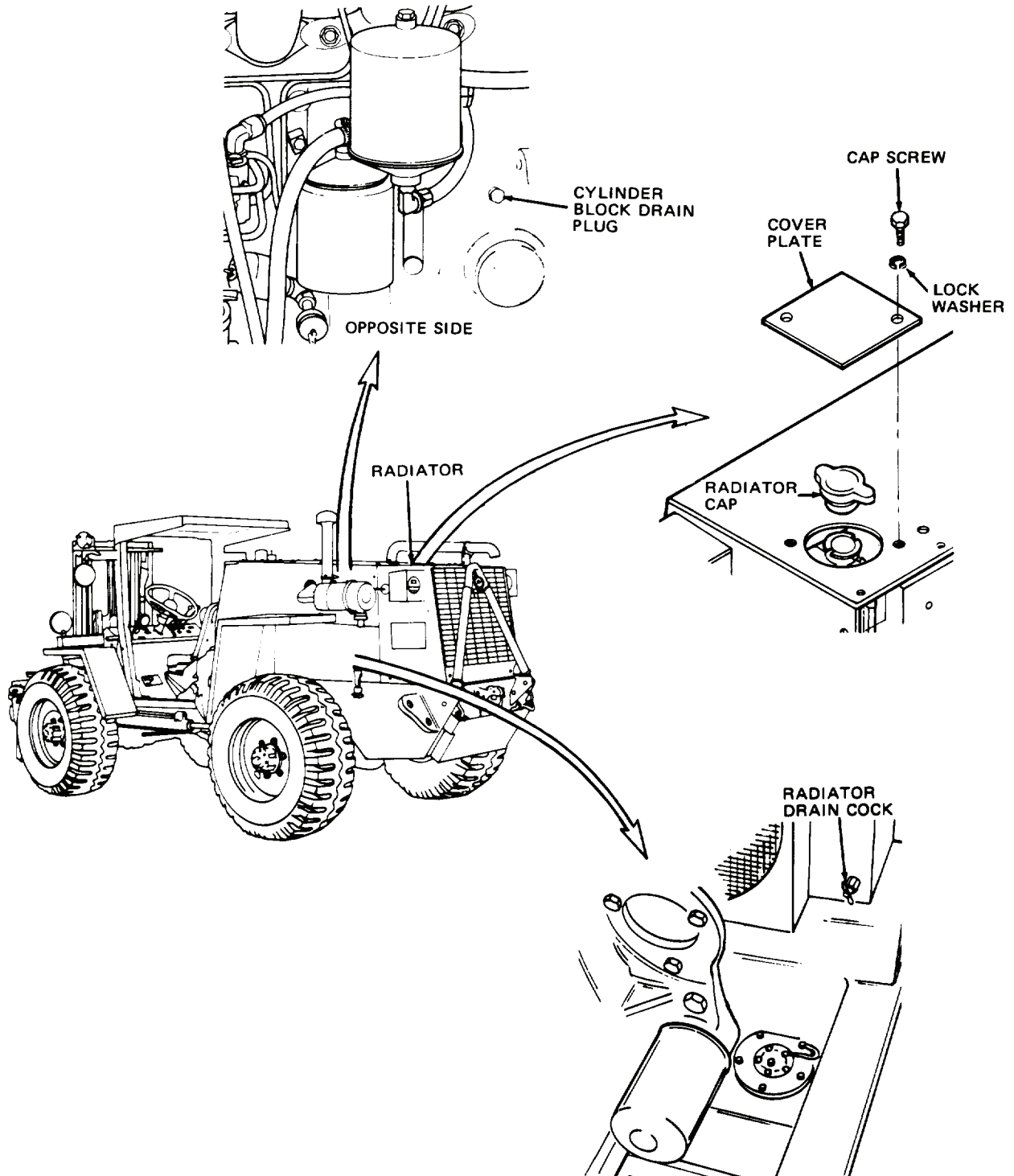

TA126882

Figure 1. Radiator Service.

END OF TASK

END OF WORK PACKAGE



---

# ORGANIZATIONAL MAINTENANCE INSTRUCTIONS

## RADIATOR SERVICING (MODEL 4-390)

### Service

---

#### INITIAL SETUP

**Maintenance Level**

Organizational

**Tools and Special Tools**

Tool kit, general mechanic's (Item 15, WP 0309)  
Shop equipment, common no. 1 (Item 2, WP 0309)  
Container, 5-gal. capacity

**Materials/Parts**

Antifreeze (Item 4, WP 0310)  
Cleaning compound, solvent (Item 10, WP 0310)

**Materials/Parts - Continued**

Rag, wiping (Item 26, WP 0310)

**References**

WP 0176

**Equipment Condition**

Vehicle on level surface  
Parking brake applied  
Engine warm and turned OFF  
Left side panel removed (WP 0179)

---

**SERVICE**

1. Remove two capscrews (Figure 1, Item 1), washers (Figure 1, Item 2), and cover plate (Figure 1, Item 3) from vehicle.

**WARNING**

Remove radiator cap slowly to relieve pressure before completely removing when engine is hot. Failure to follow this warning may result in injury to personnel.

2. Remove radiator cap (Figure 1, Item 4) from radiator (Figure 1, Item 7).
3. Open drain cock (Figure 1, Item 5) at engine coolant adapter and allow coolant to drain into container placed under vehicle.
4. Close drain cock (Figure 1, Item 5).
5. Remove cylinder block drain plug (Figure 1, Item 6) and allow remaining coolant to drain into container.
6. Install cylinder block drain plug (Figure 1, Item 6).

**NOTE**

To flush with water, fill radiator with water and operate engine for 15 minutes. Drain system. Reinstall drain plug and close drain cock.

7. Use clean water or chemical cooling system cleaner to fill and flush cooling system.

**WARNING**

Particles blown by compressed air are hazardous. DO NOT exceed 30 PSI (207 kPa) nozzle pressure when cleaning parts with compressed air. DO NOT direct compressed air against human skin. Failure to follow this warning may result in injury to personnel. Make sure air stream is directed away from user and other personnel in the area. To prevent injury, user must wear protective goggles or face shield.

8. Use compressed air to clean exterior and to remove foreign matter obstructing passage of air through radiator.
9. Fill with coolant solution to 2 in. (51 mm) below level of radiator cap opening. Use solution of 50 percent water and 50 percent antifreeze. Capacity is 20 qt (19 L).
10. Install radiator cap (Figure 1, Item 4). Operate engine for 15 minutes. Check for coolant leaks at drain cock (Figure 1, Item 5) and drain plug (Figure 1, Item 6). Tighten if necessary.

**WARNING**

Remove radiator cap slowly to relieve pressure before completely removing when engine is hot. Failure to follow this warning may result in injury to personnel.

11. Remove radiator cap (Figure 1, Item 4) and check coolant level. Add coolant solution if necessary and install radiator cap.
12. Position cover plate (Figure 1, Item 3) on radiator shroud.
13. Install two washers (Figure 1, Item 2) and capscrews (Figure 1, Item 1) on cover plate (Figure 1, Item 3) and tighten capscrews.
14. Lower tow bar to ground and open grill (WP 0176).



SERVICE - CONTINUED

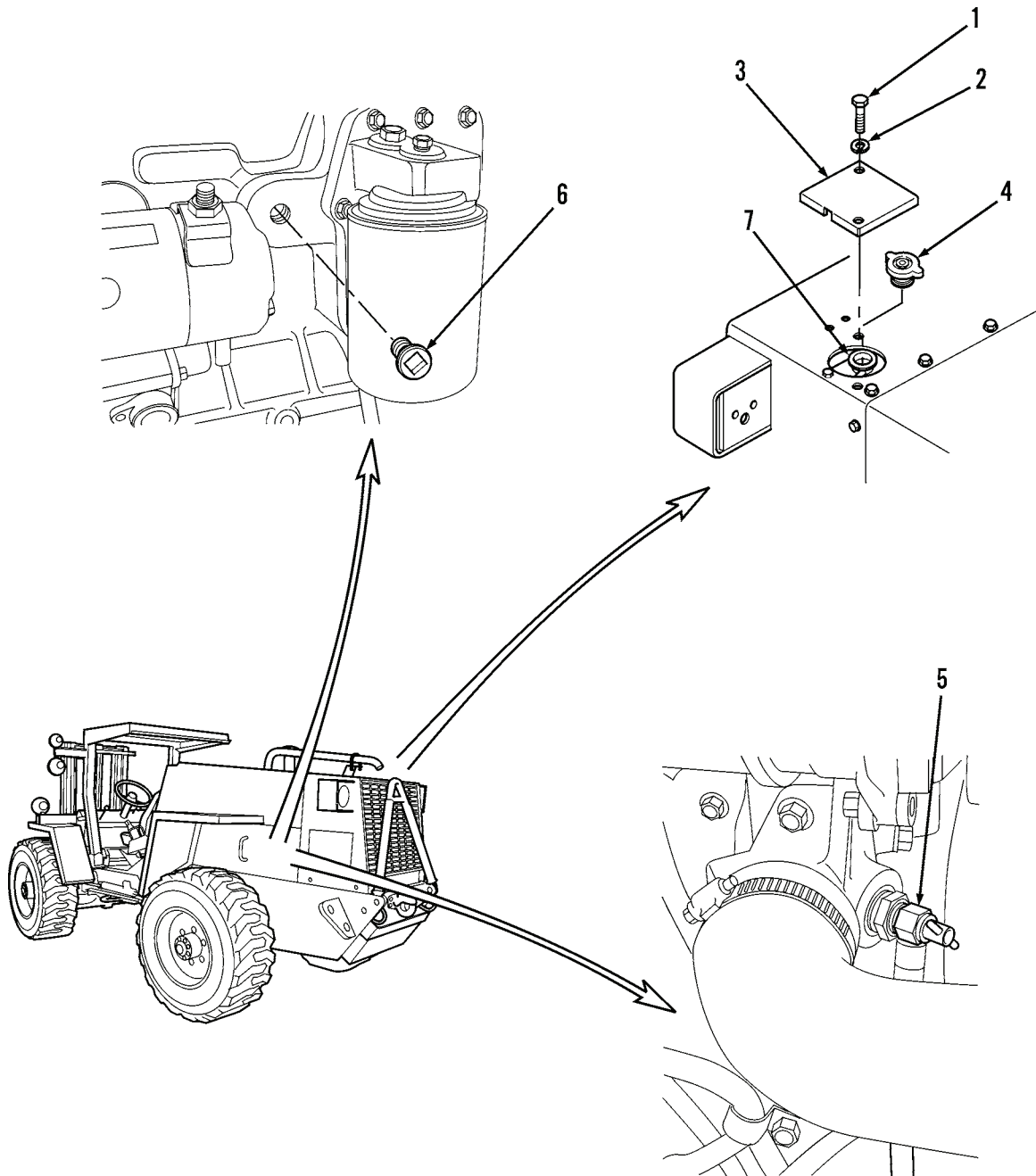

444-0067

Figure 1. Radiator Service.

**SERVICE - CONTINUED****WARNING**

Engine coolant can be very slippery. Immediately wipe up any spills. Failure to follow this warning may result in injury to personnel.

**NOTE**

When servicing this vehicle, performing maintenance, or disposing of engine coolant, consult your unit/local hazardous waste disposal center or safety office for local regulatory guidance. If further information is needed, please contact The Army Environmental Hotline at 1-800-872-3845.

15. Drain coolant from coolant recovery tank (Figure 2, Item 8). Dispose of coolant properly.
16. Remove cap (Figure 2, Item 9) and fill recovery tank (Figure 2, Item 8) half full with solution of 50 percent water and 50 percent antifreeze. Install cap.

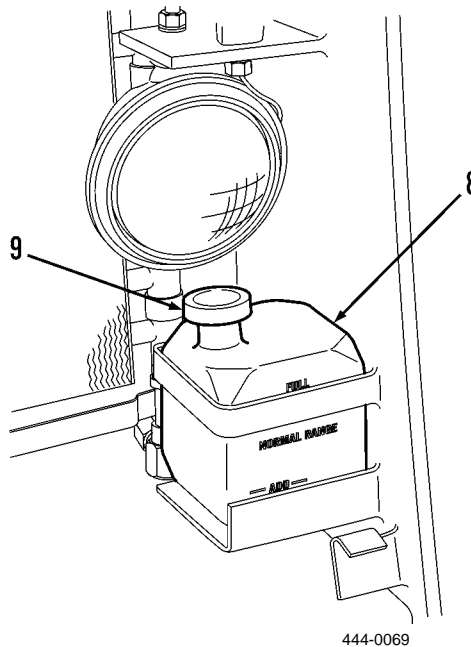

**Figure 2. Coolant Recovery Tank.**

**END OF TASK**

**END OF WORK PACKAGE**

---

# ORGANIZATIONAL MAINTENANCE INSTRUCTIONS

## RADIATOR HOSES REPLACEMENT (MODEL 207)

Removal, Installation/Replacement

---

### INITIAL SETUP

#### Maintenance Level

Organizational

#### Equipment Condition

Radiator drained (WP 0078)

#### Tools and Special Tools

Tool kit, general mechanic's (Item 15, WP 0309)

Shop equipment, common no. 1 (Item 2, WP 0309)

---

**REMOVAL**

1. Loosen two hose clamps (Figure 1, Item 1) on upper radiator hose (Figure 1, Item 2).
2. Remove upper radiator hose (Figure 1, Item 2).
3. Loosen two hose clamps (Figure 1, Item 3) on lower radiator hose (Figure 1, Item 4).
4. Remove lower radiator hose (Figure 1, Item 4).

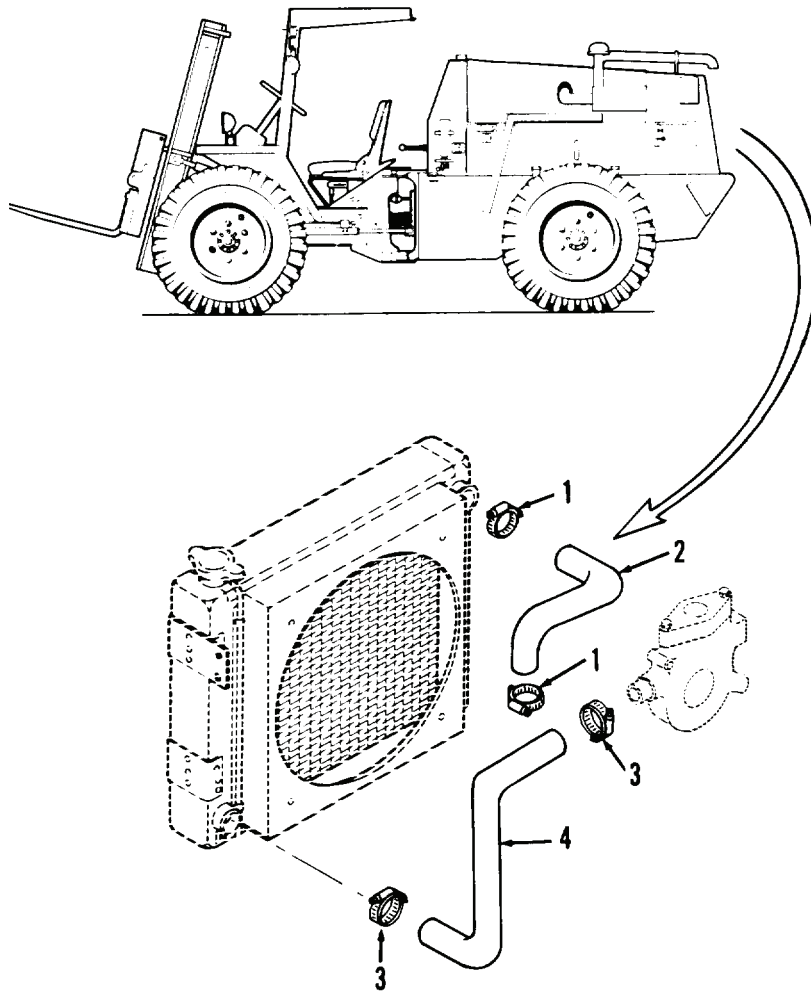

TA126883

**Figure 1. Radiator Hoses.****END OF TASK****INSTALLATION/REPLACEMENT**

1. Position two hose clamps (Figure 1, Item 3) on lower radiator hose (Figure 1, Item 4).
2. Install lower radiator hose (Figure 1, Item 4) and tighten two hose clamps (Figure 1, Item 3).
3. Position two hose clamps (Figure 1, Item 1) on upper radiator hose (Figure 1, Item 2).
4. Install upper radiator hose (Figure 1, Item 2) and tighten two hose clamps (Figure 1, Item 1).
5. Fill radiator (WP 0078).

**END OF TASK****END OF WORK PACKAGE**

---

## ORGANIZATIONAL MAINTENANCE INSTRUCTIONS

### RADIATOR HOSES REPLACEMENT (MODEL 4-390)

#### Removal, Installation/Replacement

---

#### INITIAL SETUP

**Maintenance Level**

Organizational

**Tools and Special Tools**

Tool kit, general mechanic's (Item 15, WP 0309)

Shop equipment, common no. 1 (Item 2, WP 0309)

**Materials/Parts**

Rag, wiping (Item 26, WP 0310)

**Equipment Condition**

Vehicle parked on level surface

Parking brake applied

Engine warm and turned OFF

Radiator drained (WP 0079)

---

**REMOVAL**

1. Loosen two hose clamps (Figure 1, Item 1) on ends of upper radiator hose (Figure 1, Item 2).
2. Remove bolt (Figure 1, Item 3) from clamp (Figure 1, Item 4).
3. Remove upper radiator hose (Figure 1, Item 2) from vehicle.
4. Remove two hose clamps (Figure 1, Item 1) and clamp (Figure 1, Item 4) from upper radiator hose (Figure 1, Item 2).
5. Loosen two hose clamps (Figure 1, Item 5) on ends of lower radiator hose (Figure 1, Item 6).
6. Remove lower radiator hose (Figure 1, Item 6) from vehicle.
7. Remove two hose clamps (Figure 1, Item 5) from lower radiator hose (Figure 1, Item 6).

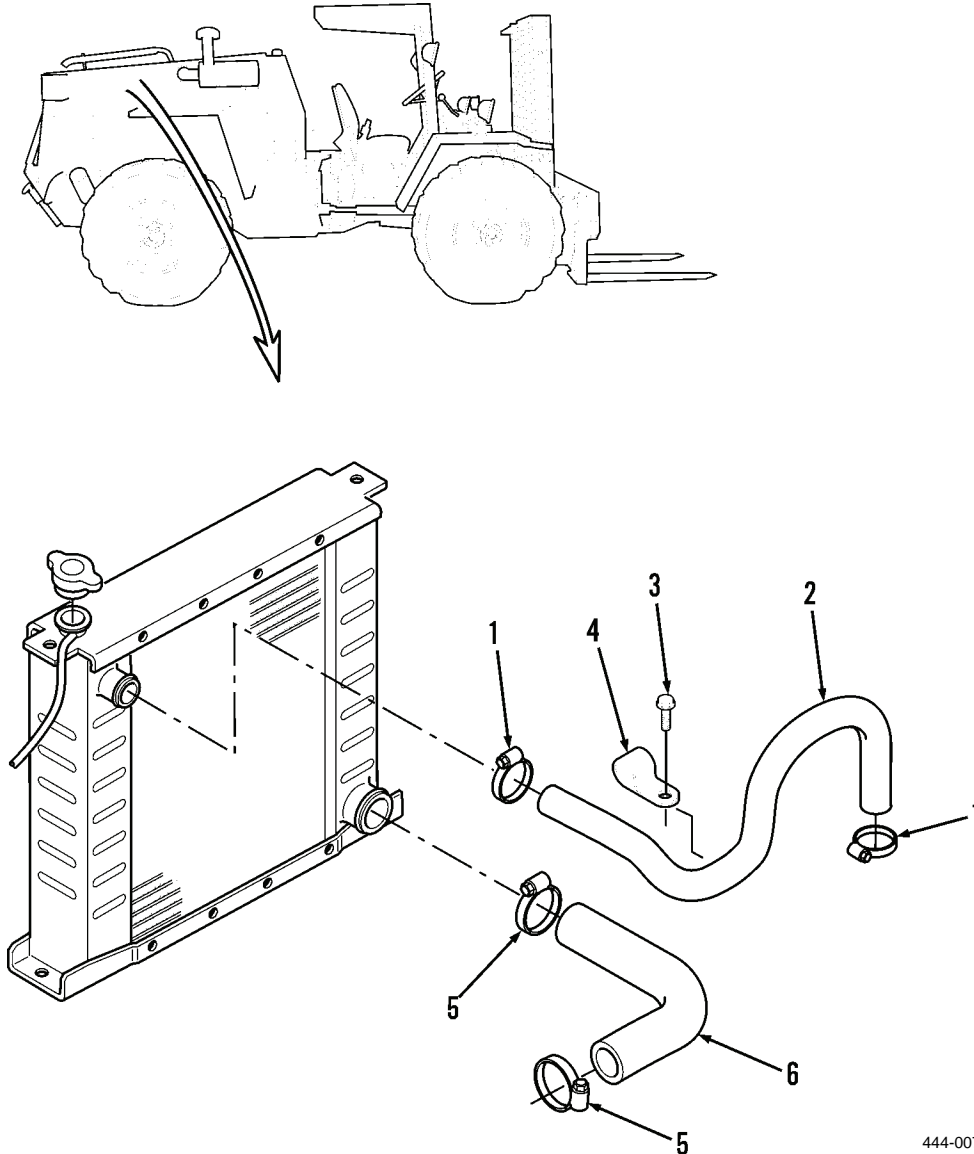
**Figure 1. Radiator Hoses.**

444-0070

**END OF TASK**

**INSTALLATION/REPLACEMENT**

1. Position two hose clamps (Figure 1, Item 5) on lower radiator hose (Figure 1, Item 6).
2. Install lower radiator hose (Figure 1, Item 6) on vehicle.
3. Tighten two hose clamps (Figure 1, Item 5).
4. Position clamp (Figure 1, Item 4) and two hose clamps (Figure 1, Item 1) on upper radiator hose (Figure 1, Item 2) and install upper radiator hose on vehicle.
5. Install bolt (Figure 1, Item 3) on clamp (Figure 1, Item 4).
6. Tighten two hose clamps (Figure 1, Item 1).
7. Fill radiator (WP 0079).

**END OF TASK****END OF WORK PACKAGE**





---

## ORGANIZATIONAL MAINTENANCE INSTRUCTIONS

### RADIATOR AND SHROUD MAINTENANCE (MODEL 207)

Removal, Disassembly, Cleaning, Inspection, Assembly, Installation

---

#### INITIAL SETUP

**Maintenance Level**

Organizational

**Personnel Required**

Two

**Tools and Special Tools**

Tool kit, general mechanic's (Item 15, WP 0309)  
Shop equipment, common no. 1 (Item 2, WP 0309)  
Lifting equipment 100-lb capacity

**References**

WP 0088

**Materials/Parts**

Cleaning compound, solvent (Item 10, WP 0310)  
Rag, wiping (Item 26, WP 0310)  
Lockwasher (6)  
Radiator mount (2)

**Equipment Condition**

Cover plate and radiator cap removed, and radiator  
and engine drained (WP 0078)  
Radiator hoses removed (WP 0080)  
Transmission oil cooler removed (WP 0153)  
Leads from two rear blackout lights disconnected  
(WP 0114)

---

**REMOVAL****NOTE**

Removal of fan may be necessary (WP 0088).

1. Disconnect overflow hose (Figure 1, Item 14) from coolant reservoir (Figure 1, Item 21).
2. Remove coolant reservoir (Figure 1, Item 21) from vehicle.
3. Loosen and remove two nuts (Figure 1, Item 1), lockwashers (Figure 1, Item 2), washers (Figure 1, Item 3), and capscrews (Figure 1, Item 4) from radiator shroud (Figure 1, Item 8) and strap (Figure 1, Item 20). Discard lockwashers.
4. Loosen and remove four nuts (Figure 1, Item 5), lockwashers (Figure 1, Item 6), and capscrews (Figure 1, Item 7) from radiator shroud (Figure 1, Item 8). Discard lockwashers.
5. Remove two capscrews (Figure 1, Item 16), nuts (Figure 1, Item 19), lockwashers (Figure 1, Item 17), and harness clamps (Figure 1, Item 18) from top of radiator shroud (Figure 1, Item 8).

**WARNING**

Use extreme caution when handling heavy parts. Provide adequate support and use assistance during procedure. ensure that any lifting equipment used is in good condition and of suitable load capacity. Keep clear of heavy parts supported only by lifting equipment. Failure to follow this warning may result in injury or death to personnel.

**NOTE**

Axle weighs approximately 400 lb (182 kg).

6. With assistance, use sling and hoist to remove radiator shroud (Figure 1, Item 8) from vehicle.

**NOTE**

Support radiator.

7. Loosen and remove two nuts (Figure 1, Item 9) and snubbing washers (Figure 1, Item 10) from radiator mounts (Figure 1, Item 12).

**CAUTION**

Exercise caution when removing radiator. Do not allow radiator fins to be damaged by engine fan or other parts during removal.

8. Remove radiator (Figure 1, Item 11) from vehicle.
9. Remove two mounts (Figure 1, Item 12) and discard.

**END OF TASK**

**DISASSEMBLY**

1. Disconnect drain hose (Figure 1, Item 13) from valve (Figure 1, Item 15).
2. Unclip overflow hose (Figure 1, Item 14) from radiator (Figure 1, Item 11) and disconnect from fitting at filler neck.

**NOTE**

Disassemble remaining parts only if required for replacement.

3. Loosen and remove drain valve (Figure 1, Item 15).
4. Loosen and remove two capscrews (Figure 1, Item 16), lockwashers (Figure 1, Item 17), washers (Figure 1, Item 18), and nuts (Figure 1, Item 19) from two support straps (Figure 1, Item 20). Discard lockwashers.
5. Remove two support straps (Figure 1, Item 20) from vehicle.

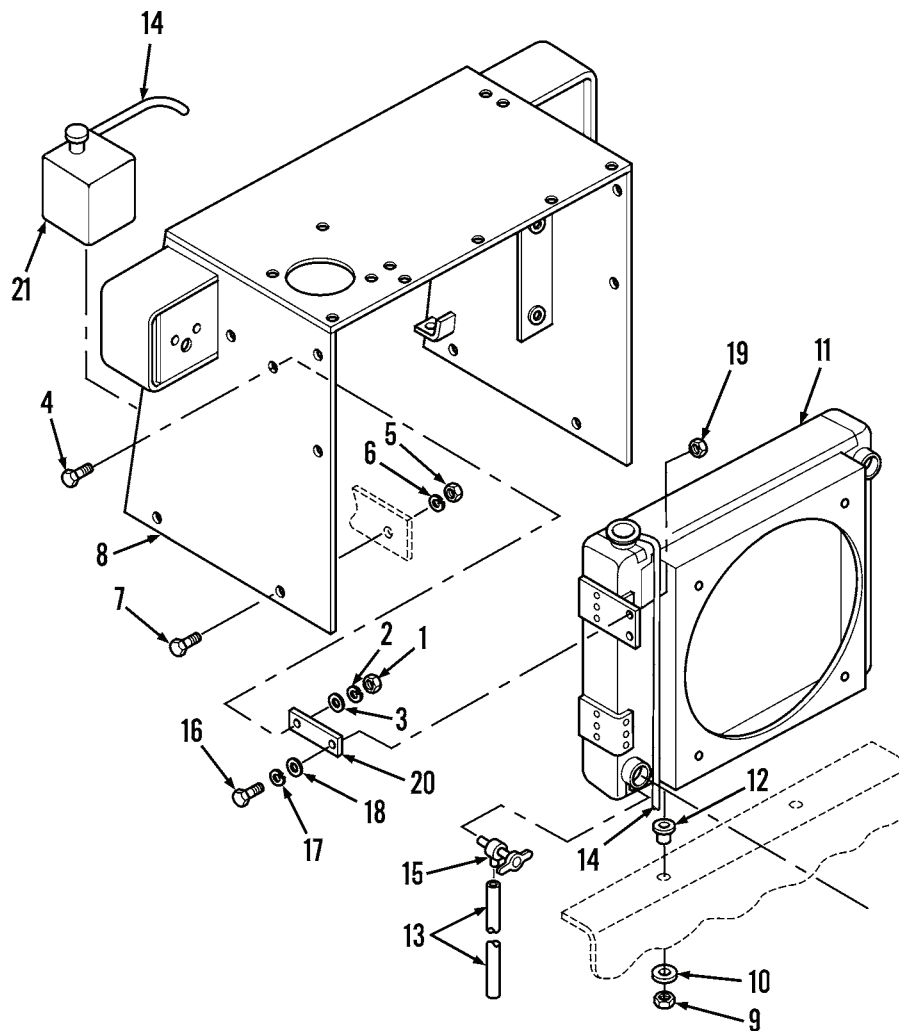

444-1038

**Figure 1. Radiator and Shroud.**

**END OF TASK**

**CLEANING**

1. Wipe hoses (Figure 2, Items 13 and 14) and coolant reservoir (Figure 2, Item 21) with clean, damp rag.

**WARNING**

- Solvent cleaning compound MIL-PRF-680 Type III is an environmentally compliant and low toxic material. However, it may be irritating to the eyes and skin. Use protective gloves and goggles. Use in well-ventilated areas. Keep away from open flames and other sources of ignition. Failure to do so may result in injury or death to personnel.
  - Particles blown by compressed air are hazardous. DO NOT exceed 15 PSI (103 kPa) nozzle pressure when drying parts with compressed air. DO NOT direct compressed air against human skin. Make sure air stream is directed away from user and other personnel in the area. To prevent injury, user must wear protective goggles or face shield. Failure to follow this warning may result in injury to personnel.
2. Use solvent cleaning compound to clean all other parts.
  3. Dry thoroughly with moisture-free compressed air.

**END OF TASK****INSPECTION**

1. Inspect radiator shroud (Figure 2, Item 8) and repair broken welds and cracks by welding (notify Direct Support Maintenance).
2. Inspect hoses (Figure 2, Items 13 and 14) and reservoir (Figure 2, Item 21) and replace if cracked, split, or deteriorated.
3. Inspect straps (Figure 2, Item 20) and replace if cracked or distorted.
4. Inspect drain valve (Figure 2, Item 15) and replace if threads damaged, or if valve obstructed or damaged.
5. Inspect all hardware and replace if worn or if threads are damaged.

**CAUTION**

Be careful not to damage core.

6. Inspect cooling fins and core of radiator (Figure 2, Item 11). Straighten bent fins.
7. Repair leaking core tubes by soldering (notify Direct Support Maintenance).

**END OF TASK****ASSEMBLY**

1. Position strap (Figure 2, Item 20) on radiator (Figure 2, Item 11).
2. Install and hand-tighten nut (Figure 2, Item 19), capscrew (Figure 2, Item 16), new lockwasher (Figure 2, Item 17), and washer (Figure 2, Item 18).
3. Repeat steps 1 and 2 for other strap (Figure 2, Item 20).
4. Install drain valve (Figure 2, Item 15) and tighten until valve opening faces bottom of radiator (Figure 2, Item 11).
5. Install overflow hose (Figure 2, Item 14).
6. Install drain hose (Figure 2, Item 13) and push onto valve opening.

ASSEMBLY - CONTINUED

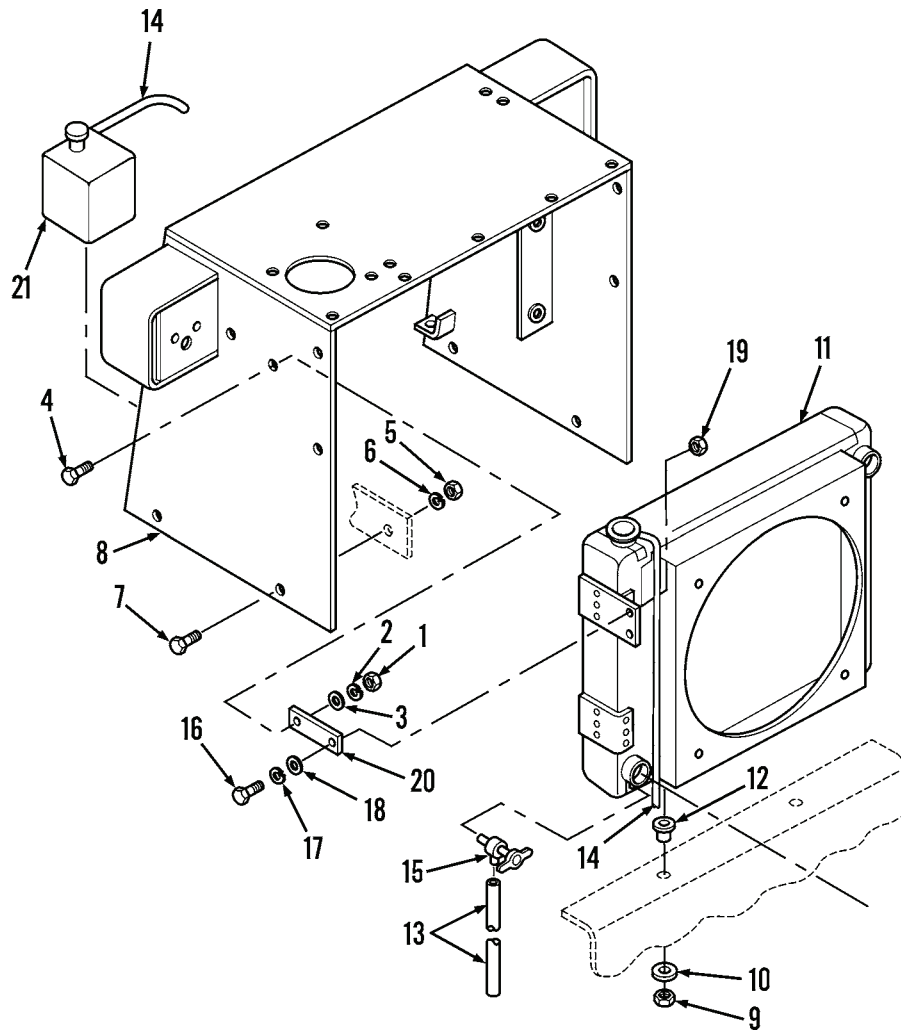

444-1038

Figure 2. Radiator and Shroud.

END OF TASK

## INSTALLATION/REPLACEMENT

1. Install two new mounts (Figure 3, Item 12) on top of radiator mounting holes.

### CAUTION

Exercise caution when installing radiator. Do not allow radiator fins to be damaged by engine fan or other parts during installation.

2. Using sling and lifting device, carefully lower radiator (Figure 3, Item 11) onto mounts (Figure 3, Item 12).
3. Install two snubbing washers (Figure 3, Item 10) and nuts (Figure 3, Item 9). Tighten nuts until mount (Figure 3, Item 12) expands equally at top and bottom of frame member.



### WARNING

Use extreme caution when handling heavy parts. Provide adequate support and use assistance during procedure. ensure that any lifting equipment used is in good condition and of suitable load capacity. Keep clear of heavy parts supported only by lifting equipment. Failure to follow this warning may result in injury or death to personnel.

### NOTE

Axle weighs approximately 400 lb (182 kg).

4. With assistance, use sling and hoist to position radiator shroud (Figure 3, Item 8) onto vehicle.
5. Install four capscrews (Figure 3, Item 7), new lockwashers (Figure 3, Item 6), and nuts (Figure 3, Item 5) and tighten nuts until radiator shroud (Figure 3, Item 8) is securely mounted.
6. Install two capscrews (Figure 3, Item 4), washers (Figure 3, Item 3), new lockwashers (Figure 3, Item 2), and nuts (Figure 3, Item 1) and tighten nuts to 20 to 30 lb-ft (27 to 41 Nm).
7. Tighten two capscrews (Figure 3, Item 16) and nuts (Figure 3, Item 19) to 20 to 30 lb-ft (27 to 41 Nm).
8. Install coolant reservoir (Figure 3, Item 21).
9. Install overflow hose (Figure 3, Item 14) and push onto reservoir cap fitting.
10. Install two capscrews (Figure 3, Item 16), nuts (Figure 3, Item 19), lockwashers (Figure 3, Item 17), and harness clamps (Figure 3, Item 18) at top of shroud (Figure 3, Item 8).
11. Install fan, if removed (WP 0088).

INSTALLATION/REPLACEMENT - CONTINUED

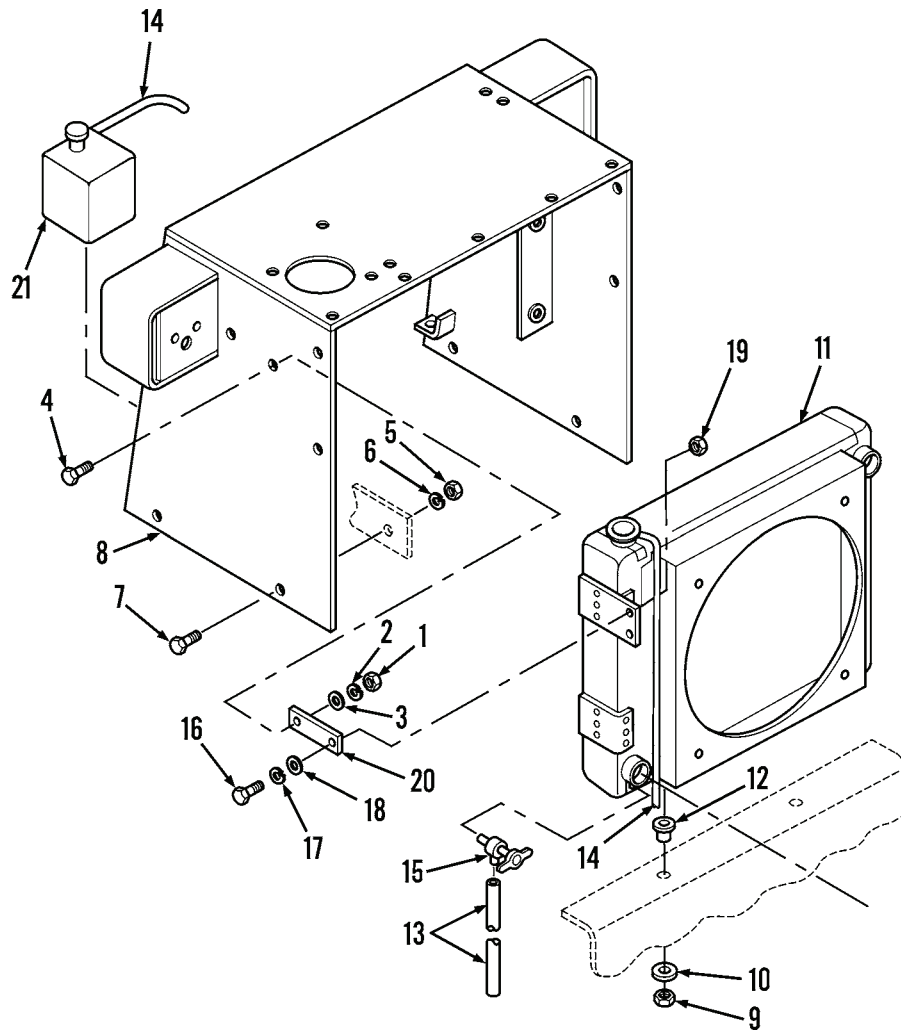

444-1038

Figure 3. Radiator and Shroud.

END OF TASK

END OF WORK PACKAGE





---

## ORGANIZATIONAL MAINTENANCE INSTRUCTIONS

### RADIATOR AND SHROUD MAINTENANCE (MODEL 4-390)

Removal, Disassembly, Cleaning, Inspection, Assembly, Installation/Replacement

---

#### INITIAL SETUP

##### Maintenance Level

Organizational

##### Tools and Special Tools

Tool kit, general mechanic's (Item 15, WP 0309)  
Shop equipment, common no. 1 (Item 2, WP 0309)  
Lifting equipment, 600-lb capacity  
Container, 1-gal. capacity

##### Materials/Parts

Cleaning compound, solvent (Item 10, WP 0310)  
Rag, wiping (Item 26, WP 0310)

##### Materials/Parts - Continued

Locknut (4)  
Lockwasher (14)

##### Personnel Required

Two

##### Equipment Condition

Cover plate removed (WP 0079)  
Side panels removed (WP 0179)  
Hood panels removed (WP 0183)  
Radiator hoses removed (WP 0081)  
Transmission oil cooler removed (WP 0153)  
Rear blackout lights removed (WP 0114)

---

## REMOVAL

1. Lift coolant reservoir (Figure 1, Item 1) from radiator shroud (Figure 1, Item 2) and empty remaining coolant into container.
2. Disconnect overflow hose (Figure 1, Item 3) from coolant reservoir (Figure 1, Item 1).
3. Disconnect other end of overflow hose (Figure 1, Item 3) from radiator (Figure 1, Item 4).
4. Remove two locknuts (Figure 1, Item 5), washers (Figure 1, Item 6), capscrews (Figure 1, Item 7), and rubber washers (Figure 1, Item 8) from top of radiator. Discard locknuts.
5. Remove two nuts (Figure 1, Item 9), lockwashers (Figure 1, Item 10), capscrews (Figure 1, Item 11), and chain (Figure 1, Item 12) of filler cap from radiator shroud (Figure 1, Item 2). Discard lockwashers.



## WARNING

Use extreme caution when handling heavy parts. Provide adequate support and use assistance during procedure. ensure that any lifting equipment used is in good condition and of suitable load capacity. Keep clear of heavy parts supported only by lifting equipment. Failure to follow this warning may result in injury or death to personnel.

## NOTE

Axle weighs approximately 400 lb (182 kg).

6. With assistance, use sling and hoist to lift and remove radiator shroud (Figure 1, Item 2) from vehicle.
7. Remove eight capscrews (Figure 1, Item 13), lockwashers (Figure 1, Item 14), washers (Figure 1, Item 15), fan guard (Figure 1, Item 16), and fan shroud (Figure 1, Item 17) from radiator (Figure 1, Item 4). Discard lockwashers.
8. Remove fan guard (Figure 1, Item 16) from vehicle. Place fan shroud (Figure 1, Item 17) between fan and engine.
9. Support radiator (Figure 1, Item 4) and remove two locknuts (Figure 1, Item 18) and capscrews (Figure 1, Item 19) from radiator support bracket (Figure 1, Item 26). Discard locknuts.

## CAUTION

Exercise caution when removing radiator. Do not allow radiator fins to be damaged by engine fan or other parts during removal.

10. Remove radiator (Figure 1, Item 4), two rubber washers (Figure 1, Item 20), and washers (Figure 1, Item 21) from vehicle.
11. Remove radiator cap (Figure 1, Item 22) from radiator (Figure 1, Item 4).
12. Remove fan shroud (Figure 1, Item 17) from between fan and engine.

## END OF TASK

## DISASSEMBLY

## NOTE

Disassemble remaining parts only if required for replacement.

Remove four nuts (Figure 1, Item 23), lockwashers (Figure 1, Item 24), capscrews (Figure 1, Item 25), and two radiator support brackets (Figure 1, Item 26) from chassis. Discard lockwashers.

**DISASSEMBLY- CONTINUED**

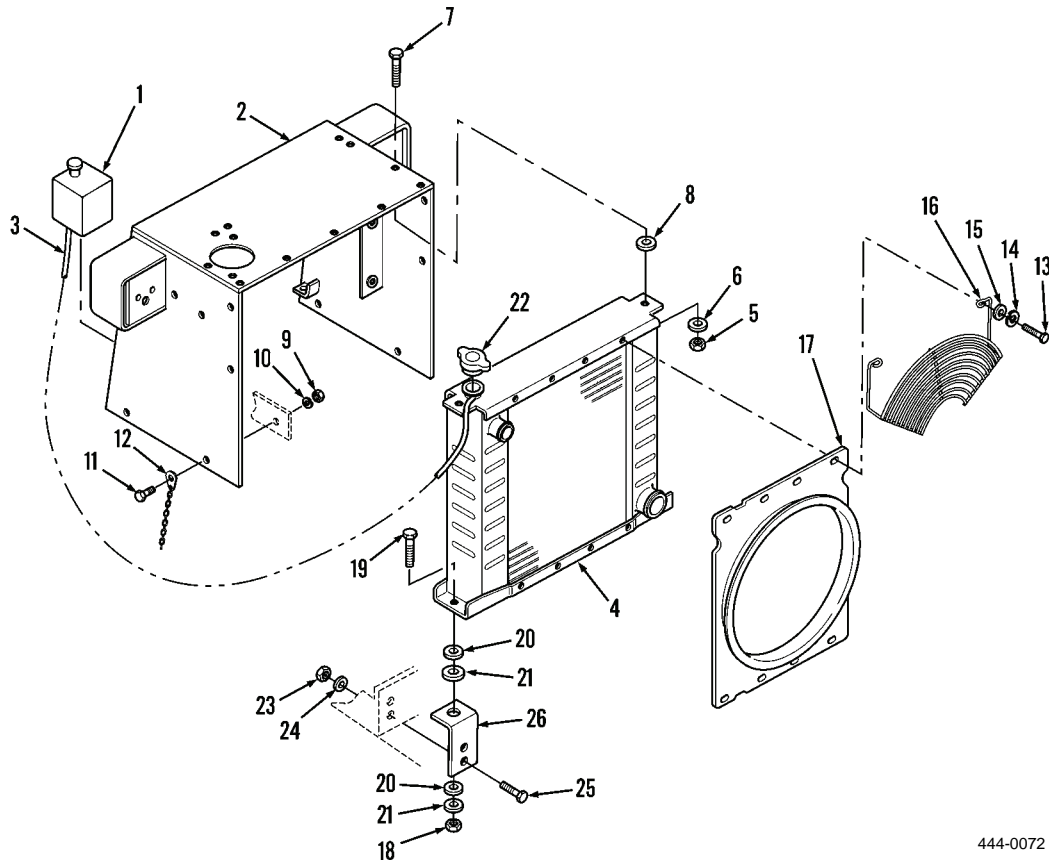

444-0072

**Figure 1. Radiator and Shroud.**

**END OF TASK**

**CLEANING**

1. Wipe coolant reservoir and overflow hose with clean, damp rag.



- Solvent cleaning compound MIL-PRF-680 Type III is an environmentally compliant and low toxic material. However, it may be irritating to the eyes and skin. Use protective gloves and goggles. Use in well-ventilated areas. Keep away from open flames and other sources of ignition. Failure to do so may result in injury or death to personnel.
- Particles blown by compressed air are hazardous. **DO NOT** exceed 15 PSI (103 kPa) nozzle pressure when drying parts with compressed air. **DO NOT** direct compressed air against human skin. Make sure air stream is directed away from user and other personnel in the area. To prevent injury, user must wear protective goggles or face shield. Failure to follow this warning may result in injury to personnel.

2. Use solvent cleaning compound to clean all other parts. Dry parts thoroughly with compressed air.

**END OF TASK**

## INSPECTION

1. Inspect radiator shroud. Repair broken welds and cracks by welding (notify Direct Support Maintenance).
2. Inspect coolant reservoir and overflow hose. Replace if cracked, split, or deteriorated.
3. Inspect all hardware. Replace if worn or if threads damaged.
4. Inspect cooling fins and core of radiator. If damaged or leaking replace radiator.

## END OF TASK

## ASSEMBLY

Install two radiator support brackets (Figure 2, Item 26), four capscrews (Figure 2, Item 25), new lockwashers (Figure 2, Item 24), and nuts (Figure 2, Item 23) on vehicle.

## END OF TASK

## INSTALLATION/REPLACEMENT

1. Position fan shroud (Figure 2, Item 17) loosely between fan and engine.
2. Install radiator cap (Figure 2, Item 22) on radiator (Figure 2, Item 4).

## CAUTION

Exercise caution when installing radiator. Do not allow radiator fins to be damaged by engine fan or other parts during installation.

3. Position two washers (Figure 2, Item 21), rubber washers (Figure 2, Item 20), and radiator (Figure 2, Item 4) on vehicle. Support radiator.
4. Install two capscrews (Figure 2, Item 19) and new locknuts (Figure 2, Item 18) and tighten locknuts to 20 to 30 lb-ft (27 to 41 Nm).
5. Install fan shroud (Figure 2, Item 17), fan guard (Figure 2, Item 16), eight washers (Figure 2, Item 15), new lockwashers (Figure 2, Item 14), and capscrews (Figure 2, Item 13) on radiator (Figure 2, Item 4).



## WARNING

Use extreme caution when handling heavy parts. Provide adequate support and use assistance during procedure. ensure that any lifting equipment used is in good condition and of suitable load capacity. Keep clear of heavy parts supported only by lifting equipment. Failure to follow this warning may result in injury or death to personnel.

## NOTE

Axle weighs approximately 400 lb (182 kg).

6. With assistance, use sling and hoist to lower radiator shroud (Figure 2, Item 2) into position on vehicle.
7. Install chain (Figure 2, Item 12) of filler cap, two capscrews (Figure 2, Item 11), new lockwashers (Figure 2, Item 10), and nuts (Figure 2, Item 9) on radiator shroud (Figure 2, Item 2).
8. Install two rubber washers (Figure 2, Item 8), capscrews (Figure 2, Item 7), washers (Figure 2, Item 6), and new locknuts (Figure 2, Item 5) on top of radiator. Tighten locknuts to 20 to 30 lb-ft (27 to 41 Nm).
9. Connect end of overflow hose (Figure 2, Item 3) to radiator (Figure 2, Item 4).

**INSTALLATION/REPLACEMENT - CONTINUED**

10. Route other end of overflow hose (Figure 2, Item 3) up through hole in radiator shroud (Figure 2, Item 2) and connect to bottom of coolant reservoir (Figure 2, Item 1).
11. Position coolant reservoir (Figure 2, Item 1) on radiator shroud (Figure 2, Item 2).

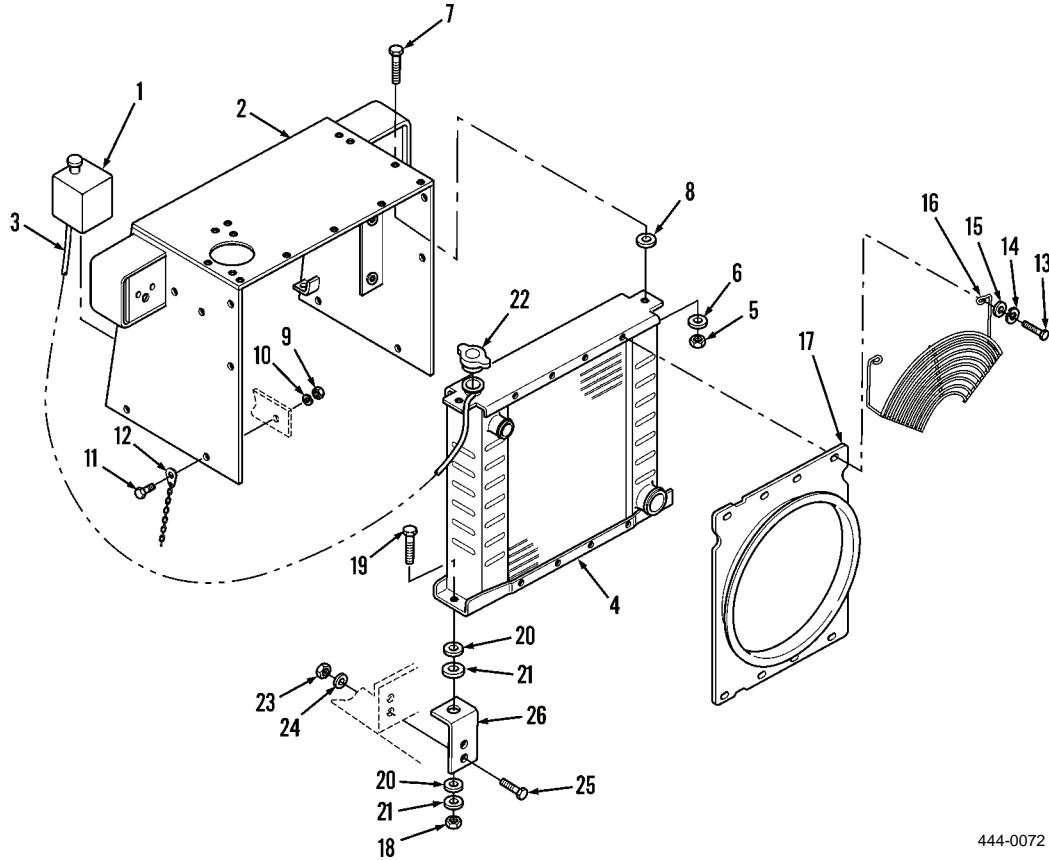

444-0072

**Figure 2. Radiator and Shroud.**

**END OF TASK**

**END OF WORK PACKAGE**



## ORGANIZATIONAL MAINTENANCE INSTRUCTIONS

### THERMOSTAT AND HOUSING MAINTENANCE (MODEL 207)

Removal, Cleaning, Inspection, Testing, Installation/Replacement

#### INITIAL SETUP

##### Maintenance Level

Organizational

##### Tools and Special Tools

Tool kit, general mechanic's (Item 15, WP 0309)

Shop equipment, common no. 1 (Item 2, WP 0309)

Glass container

Thermometer

##### Materials/Parts

Cleaning compound, solvent (Item 10, WP 0310)

##### Materials/Parts - Continued

Rag, wiping (Item 26, WP 0310)

Gasket

Hot water

Lockwasher (2)

##### Equipment Condition

Side panels removed (WP 0179)

Radiator drained (WP 0078)

Upper radiator hose removed (WP 0080)

#### REMOVAL

1. Remove two capscrews (Figure 1, Item 1) and lockwashers (Figure 1, Item 2) from housing (Figure 1, Item 3). Discard lockwashers.
2. Remove housing (Figure 1, Item 3) from vehicle.
3. Remove and discard gasket (Figure 1, Item 4).
4. Remove thermostat (Figure 1, Item 5) from vehicle.

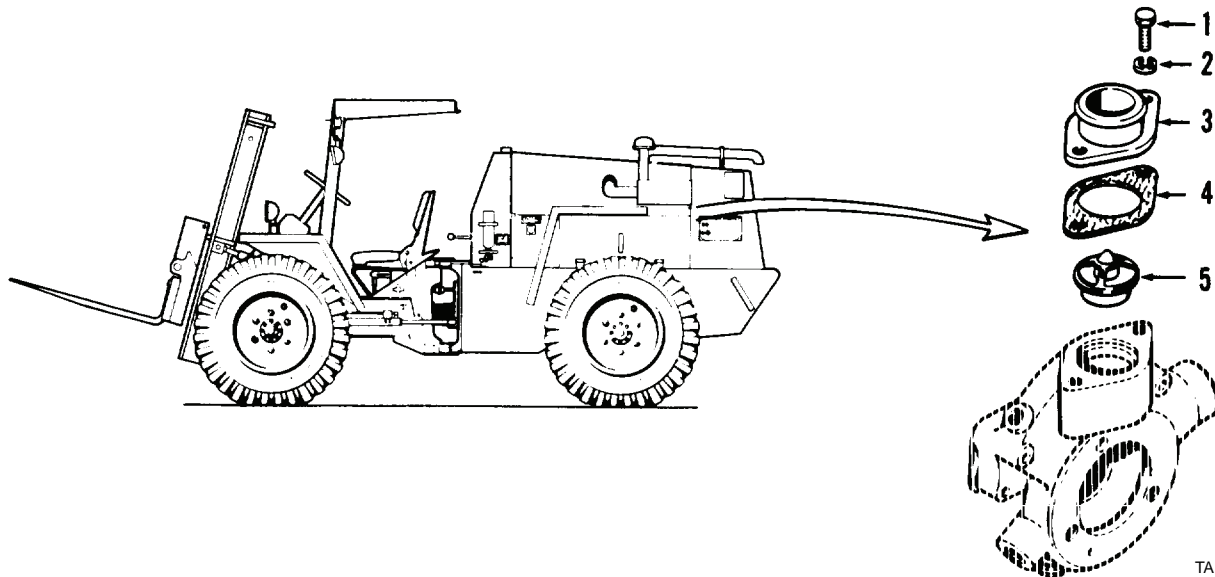

TA126885

Figure 1. Thermostat and Housing.

END OF TASK

**CLEANING**

- Solvent cleaning compound MIL-PRF-680 Type III is an environmentally compliant and low toxic material. However, it may be irritating to the eyes and skin. Use protective gloves and goggles. Use in well-ventilated areas. Keep away from open flames and other sources of ignition. Failure to do so may result in injury or death to personnel.
- Particles blown by compressed air are hazardous. DO NOT exceed 15 PSI (103 kPa) nozzle pressure when drying parts with compressed air. DO NOT direct compressed air against human skin. Make sure air stream is directed away from user and other personnel in the area. To prevent injury, user must wear protective goggles or face shield. Failure to follow this warning may result in injury to personnel.

Use solvent cleaning compound to clean all parts. Dry thoroughly with compressed air. Remove all gasket material from housing and water pump mating surfaces.

**END OF TASK****INSPECTION**

Inspect all parts and replace if cracked, damaged, or have damaged threads.

**END OF TASK****TESTING**

Submerge thermostat in 175°F (79°C) water with thermometer (Figure 2). Heat water. Thermostat should just start to open between 175 to 182°F (79 to 83°C) and be completely open at 202°F (94°C). Remove and dry with compressed air. Replace thermostat if it does not meet specification.

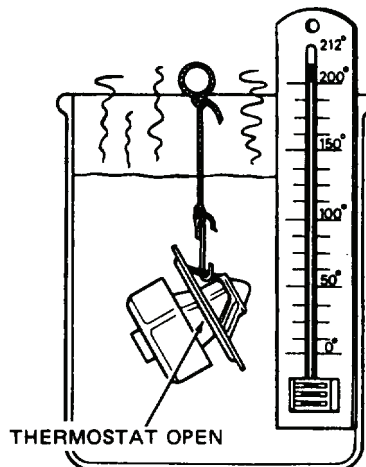

TA126886

**Figure 2. Thermostat Testing.**

**END OF TASK**



**INSTALLATION/REPLACEMENT**

1. Install thermostat (Figure 4, Item 5) on vehicle, oriented as shown in Figure 3.

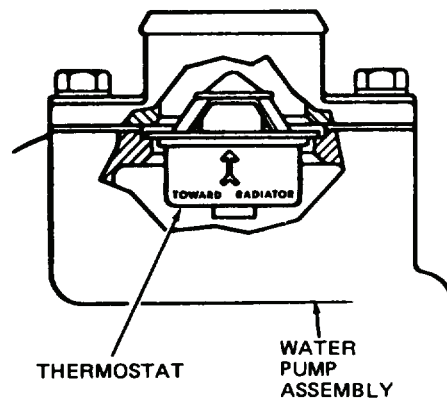

TA126887

**Figure 3. Thermostat.**

2. Install new gasket (Figure 4, Item 4) on vehicle.
3. Position housing (Figure 4, Item 3) on new gasket (Figure 4, Item 4).
4. Install two new lockwashers (Figure 4, Item 2) and capscrews (Figure 4, Item 1) on housing (Figure 4, Item 3).

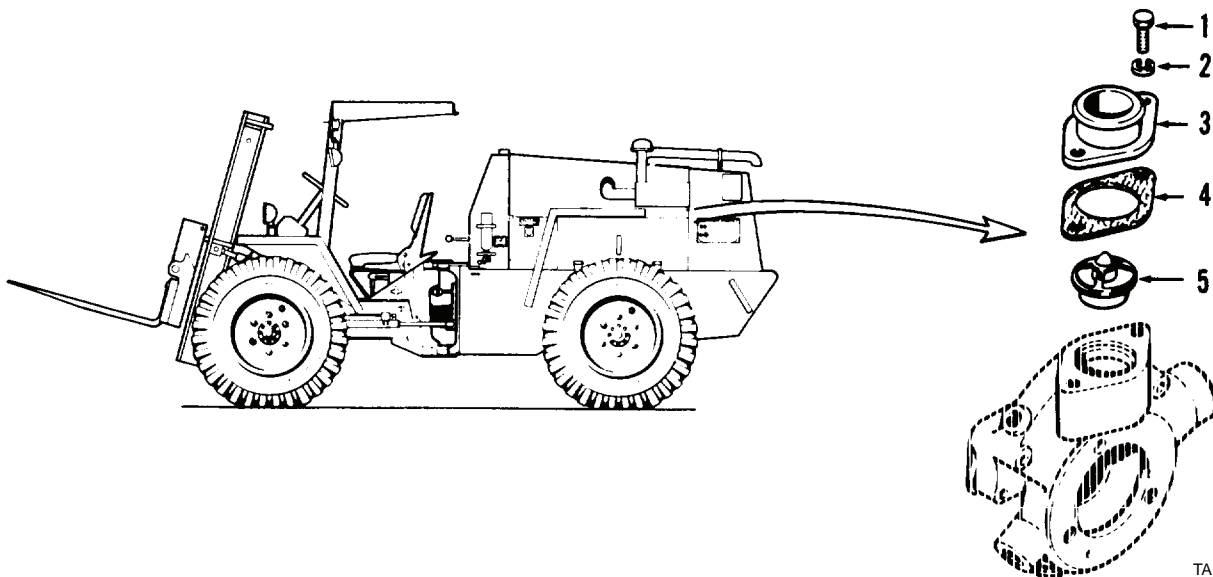

TA126885

**Figure 4. Thermostat and Housing.****END OF TASK****END OF WORK PACKAGE**



## ORGANIZATIONAL MAINTENANCE INSTRUCTIONS

### THERMOSTAT AND HOUSING MAINTENANCE (MODEL 4-390)

Removal, Cleaning, Inspection, Testing, Installation/Replacement

#### INITIAL SETUP

##### Maintenance Level

Organizational

##### Tools and Special Tools

Tool kit, general mechanic's (Item 15, WP 0309)  
 Shop equipment, common no. 1 (Item 2, WP 0309)  
 Glass container  
 Thermometer

##### Materials/Parts

Cleaning compound, solvent (Item 10, WP 0310)  
 Rag, wiping (Item 26, WP 0310)  
 Hot water  
 Seal

##### Equipment Condition

Upper radiator hose removed (WP 0081)  
 Alternator and bracket removed (WP 0094)  
 Belt tensioner removed (WP 0090)

#### REMOVAL

1. Remove two capscrews (Figure 1, Item 1) and capscrew (Figure 1, Item 2) from thermostat housing (Figure 1, Item 3).
2. Remove thermostat housing (Figure 1, Item 3) from cylinder head.
3. Remove thermostat (Figure 1, Item 4) from thermostat housing (Figure 1, Item 3).
4. Remove seal (Figure 1, Item 5) from thermostat (Figure 1, Item 4). Discard seal.
5. Remove lifting eye (Figure 1, Item 6) from cylinder head.

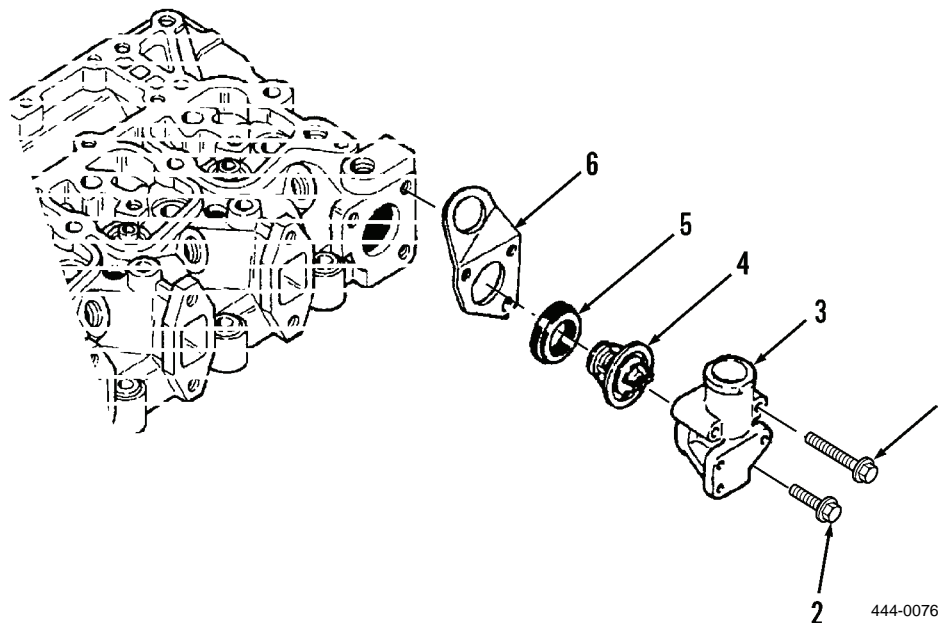

Figure 1. Thermostat and Housing Assembly.

END OF TASK

**CLEANING****WARNING**

- Solvent cleaning compound MIL-PRF-680 Type III is an environmentally compliant and low toxic material. However, it may be irritating to the eyes and skin. Use protective gloves and goggles. Use in well-ventilated areas. Keep away from open flames and other sources of ignition. Failure to do so may result in injury or death to personnel.
- Particles blown by compressed air are hazardous. DO NOT exceed 15 PSI (103 kPa) nozzle pressure when drying parts with compressed air. DO NOT direct compressed air against human skin. Make sure air stream is directed away from user and other personnel in the area. To prevent injury, user must wear protective goggles or face shield. Failure to follow this warning may result in injury to personnel.

Use solvent cleaning compound to clean all parts. Dry thoroughly with compressed air. Remove all remaining gasket materials.

**END OF TASK****INSPECTION**

Inspect all parts. Replace if cracked, damaged, or have damaged threads.

**END OF TASK****TESTING**

Submerge thermostat in 175°F (79°C) water with thermometer (Figure 2). Heat water. Thermostat must just start to open between 175 to 182°F (79 to 83°C) and be completely open at 202°F (94°C). Remove and dry with compressed air. Replace thermostat if it does not meet specification.

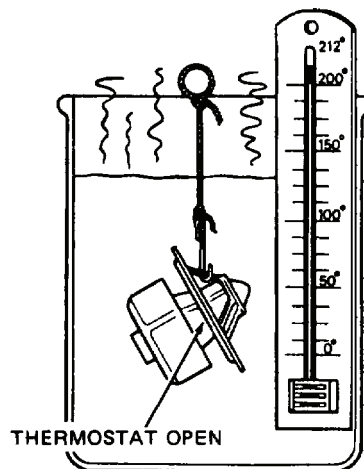

444-0077

**Figure 2. Thermostat Testing.**

**END OF TASK**

**INSTALLATION/REPLACEMENT**

1. Position lifting eye (Figure 3, Item 6) on cylinder head.
2. Install new seal (Figure 3, Item 5) on thermostat (Figure 3, Item 4).
3. Install thermostat (Figure 3, Item 4) on thermostat housing (Figure 3, Item 3).
4. Install thermostat housing (Figure 3, Item 3) on engine lifting eye (Figure 3, Item 6).
5. Install capscrew (Figure 3, Item 2) and two capscrews (Figure 3, Item 1) on thermostat housing (Figure 3, Item 3). Tighten capscrews to 15 to 20 lb-ft (20 to 27 Nm).

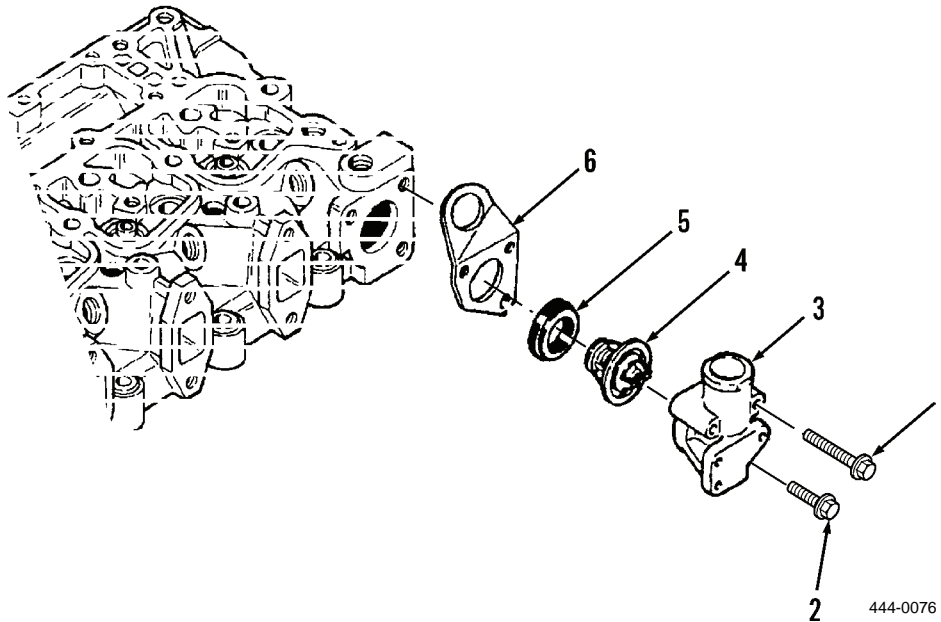

**Figure 3. Thermostat and Housing Assembly.**

**END OF TASK**

**END OF WORK PACKAGE**



---

## ORGANIZATIONAL MAINTENANCE INSTRUCTIONS

### WATER PUMP REPLACEMENT (MODEL 207)

#### Removal, Installation/Replacement

---

#### INITIAL SETUP

**Maintenance Level**

Organizational

**Tools and Special Tools**

Tool kit, general mechanic's (Item 15, WP 0309)

Shop equipment, common no. 1 (Item 2, WP 0309)

**Materials/Parts**

Lubriplate (Item 23, WP 0310)

Gasket

**Materials/Parts - Continued**

Lockwasher (3)

O-ring

**Equipment Condition**

Left and right side panels removed (WP 0179)

Radiator drained (WP 0078)

Radiator hoses removed (WP 0080)

Thermostat and housing removed (WP 0084)

Fan and drive belt removed (WP 0088)

---

**REMOVAL**

1. Remove capscrew (Figure 1, Item 1) and sealing washer (Figure 1, Item 2) from water pump assembly (Figure 1, Item 10).
2. Remove capscrew (Figure 1, Item 3) and lockwasher (Figure 1, Item 4) from water pump assembly (Figure 1, Item 10). Discard lockwasher.
3. Move alternator mounting strap aside and remove capscrew (Figure 1, Item 5) and lockwasher (Figure 1, Item 6) from water pump assembly (Figure 1, Item 10). Discard lockwasher.
4. Remove capscrew (Figure 1, Item 7), lockwasher (Figure 1, Item 8), and two washers (Figure 1, Item 9) from water pump assembly (Figure 1, Item 10). Discard lockwasher.

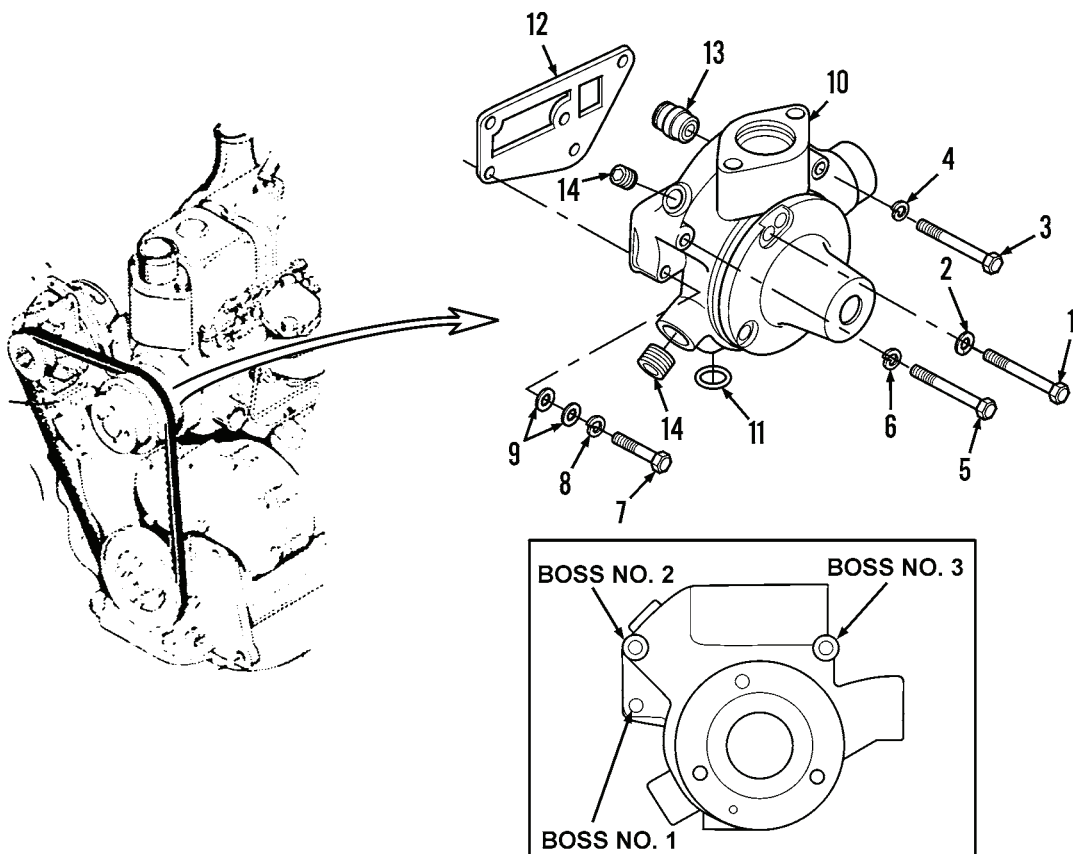

444-1041

**Figure 1. Water Pump Assembly.**



**REMOVAL - CONTINUED**

5. Remove water pump assembly as shown in (Figure 2).

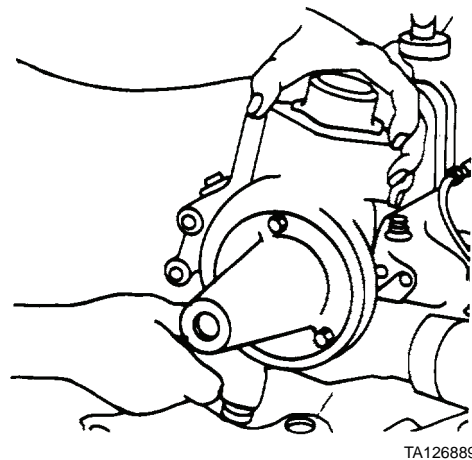

**Figure 2. Water Pump.**

6. Remove O-ring (Figure 1, Item 11) from water pump assembly (Figure 1, Item 10). Discard O-ring.
7. Remove gasket (Figure 1, Item 12) from engine. Discard gasket.
8. Loosen and remove inlet fitting (Figure 1, Item 13), if required.
9. Loosen and remove two pipe plugs (Figure 1, Item 14), if required.

**END OF TASK****INSTALLATION/REPLACEMENT**

1. Install two pipe plugs (Figure 1, Item 14), if removed, and tighten.
2. Install inlet fitting (Figure 1, Item 13), if removed, and tighten.

**NOTE**

Be sure all old gasket material is removed from mounting surface.

3. Install new gasket (Figure 1, Item 12).
4. Install new O-ring (Figure 1, Item 11).
5. Position water pump assembly (Figure 1, Item 10) on cylinder head and timing gear housing.
6. Install two washers (Figure 1, Item 9), new lockwasher (Figure 1, Item 8), and capscrew (Figure 1, Item 7) (2-1/4 in. long) in boss no. 1.
7. Position alternator mounting strap.
8. Install new lockwasher (Figure 1, Item 6) and capscrew (Figure 1, Item 5) (3 in. long) in boss no. 2.
9. Install new lockwasher (Figure 1, Item 4) and capscrew (Figure 1, Item 3) (2-3/4 in. long) in boss no. 3.
10. Tighten capscrews (Figure 1, Items 3, 5, and 7) to 35 to 42 lb-ft (47 to 60 Nm).
11. Install sealing washer (Figure 1, Item 2) and capscrew (Figure 1, Item 1). Tighten capscrew to 35 to 42 lb-ft (47 to 60 Nm).

**END OF TASK****END OF WORK PACKAGE**



---

## ORGANIZATIONAL MAINTENANCE INSTRUCTIONS

### WATER PUMP REPLACEMENT (MODEL 4-390)

#### Removal, Installation/Replacement

---

#### INITIAL SETUP

**Maintenance Level**

Organizational

**Tools and Special Tools**

Tool kit, general mechanic's (Item 15, WP 0309)

Shop equipment, common no. 1 (Item 2, WP 0309)

**Materials/Parts**

Rag, wiping (Item 26, WP 0310)

**Materials/Parts - Continued**

O-ring

**Equipment Condition**

Left side panel removed (WP 0179)

Left hood panel removed (WP 0183)

Radiator drained (WP 0079)

Alternator removed (WP 0094)

---

**REMOVAL**

1. Remove two capscrews (Figure 1, Item 1) from water pump (Figure 1, Item 2).
2. Remove water pump (Figure 1, Item 2) from engine cylinder block.
3. Remove O-ring (Figure 1, Item 3) from water pump (Figure 1, Item 2). Discard O-ring.

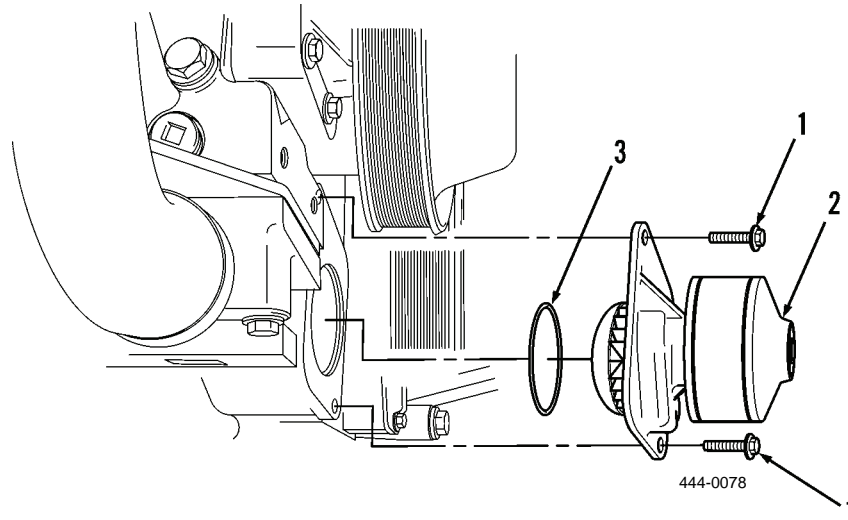
**Figure 1. Water Pump.****END OF TASK****INSTALLATION/REPLACEMENT**

1. Install new O-ring (Figure 1, Item 3) on water pump (Figure 1, Item 2).
2. Install water pump (Figure 1, Item 2) on engine cylinder block.
3. Install two capscrews (Figure 1, Item 1) on water pump (Figure 1, Item 2). Tighten capscrew to 15 to 20 lb-ft (20 to 27 Nm).

**END OF TASK****END OF WORK PACKAGE**

---

## ORGANIZATIONAL MAINTENANCE INSTRUCTIONS

### FAN AND FAN BELT MAINTENANCE (MODEL 207)

Removal, Cleaning, Inspection, Installation/Replacement, Fan Belt Adjustment

---

#### INITIAL SETUP

**Maintenance Level**

Organizational

**Tools and Special Tools**

Tool kit, general mechanic's (Item 15, WP 0309)

Shop equipment, common no. 1 (Item 2, WP 0309)

**Materials/Parts**

Cleaning compound, solvent (Item 10, WP 0310)

Lockwasher (4)

**Equipment Condition**

Left and right side panels removed (WP 0179)

---

#### NOTE

Removal or adjustment of fan belt requires removal of left side panel only.

**REMOVAL**

1. Remove alternator adjustment screw and mounting screw.
2. Remove alternator from engine.
3. Remove fan belt (Figure 1, Item 1) from engine.
4. Remove four capscrews (Figure 1, Item 2) and lockwashers (Figure 1, Item 3) from fan blade assembly (Figure 1, Item 4). Discard lockwashers.
5. Remove fan blade assembly (Figure 1, Item 4) from engine.
6. Remove water pump pulley (Figure 1, Item 5) from engine.

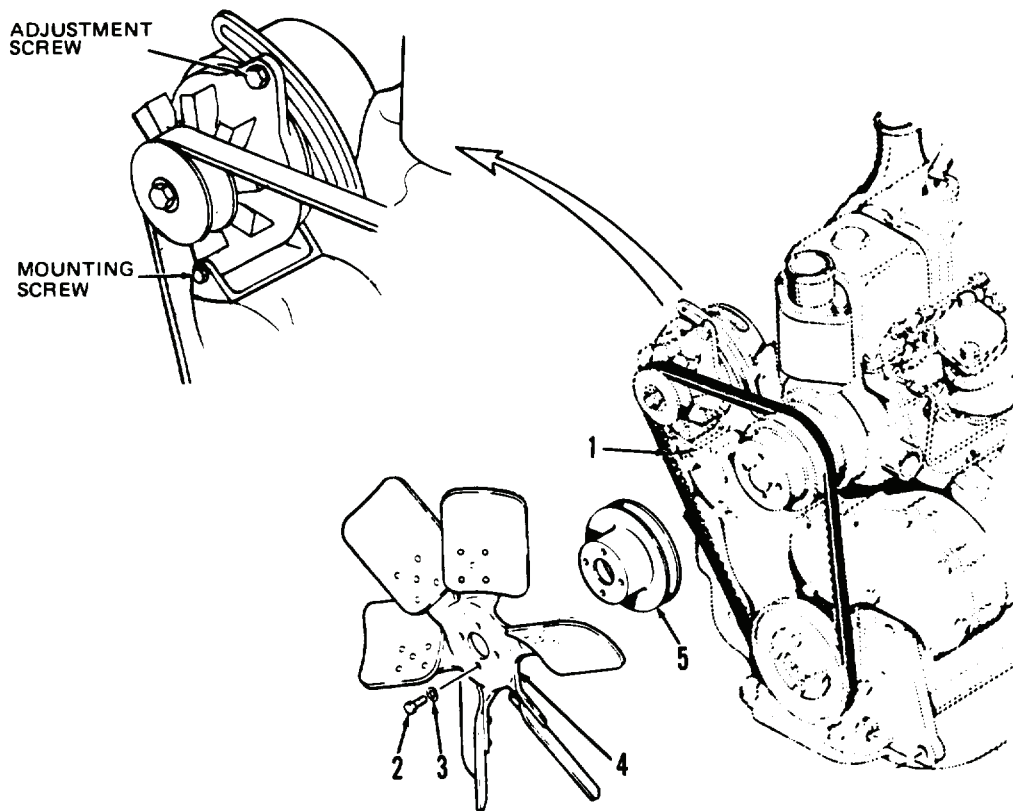

Figure 1. Fan Belt and Fan.

TA126890

**END OF TASK**

**CLEANING****WARNING**

Solvent cleaning compound MIL-PRF-680 Type III is an environmentally compliant and low toxic material. However, it may be irritating to the eyes and skin. Use protective gloves and goggles. Use in well-ventilated areas. Keep away from open flames and other sources of ignition. Failure to do so may result in injury or death to personnel.

Use solvent cleaning compound to clean all parts and dry thoroughly.

**END OF TASK****INSPECTION**

1. Inspect fan belt (Figure 1, Item 1). Replace if cracked, ruptured, or worn.
2. Inspect fan blade assembly (Figure 1, Item 4). Replace if blades are cracked, bent, or broken.
3. Inspect water pump pulley (Figure 1, Item 5). Replace if bent, cracked, or mounting holes damaged.

**END OF TASK****INSTALLATION/REPLACEMENT**

1. Position water pump pulley (Figure 1, Item 5) on water pump assembly.
2. Position fan blade assembly (Figure 1, Item 4) on water pump pulley.
3. Install four new lockwashers (Figure 1, Item 3) and capscrews (Figure 1, Item 2) on fan blade assembly (Figure 1, Item 4). Tighten capscrews in sequence shown (Figure 2).
4. Install fan belt (Figure 1, Item 1) on engine.
5. Install alternator on engine.
6. Install alternator adjustment screw and mounting screw.

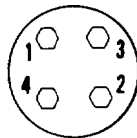

TA301520

**Figure 2. Tightening Sequence.****END OF TASK**

**FAN BELT ADJUSTMENT**

1. Depress fan belt. Belt should deflect 1/2 in. as shown (Figure 3).

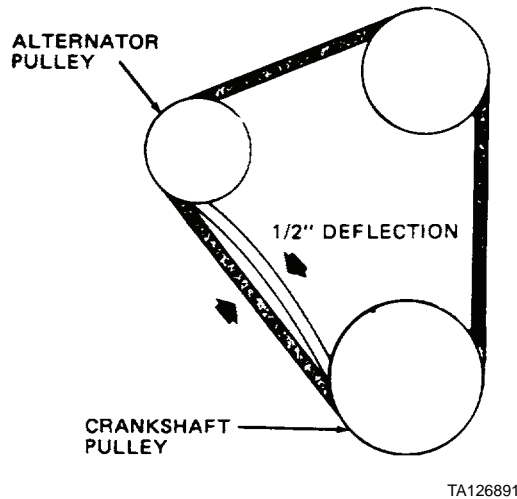

**Figure 3. Fan Belt Deflection.**

2. Loosen alternator adjustment screw and mounting screw.
3. Move alternator toward engine to loosen fan belt or away from engine to tighten; use pry bar if necessary.
4. When proper deflection of fan belt is obtained (step 1), tighten alternator adjustment screw and mounting screw.

**END OF TASK**

**END OF WORK PACKAGE**



---

## ORGANIZATIONAL MAINTENANCE INSTRUCTIONS

### FAN AND FAN BELT REPLACEMENT (MODEL 4-390)

Removal, Cleaning, Inspection, Installation/Replacement

---

#### INITIAL SETUP

**Maintenance Level**

Organizational

**Tools and Special Tools**

Tool kit, general mechanic's (Item 15, WP 0309)

Shop equipment, common no. 1 (Item 2, WP 0309)

**Materials/Parts**

Cleaning compound, solvent (Item 10, WP 0310)

**Materials/Parts - Continued**

Rag, wiping (Item 26, WP 0310)

Lockwasher (4)

**Personnel Required**

Two

**Equipment Condition**

Left side panel removed (WP 0179)

Left hood panel removed (WP 0183)

Fan guard and fan shroud removed (WP 0083)

---

**REMOVAL**

1. Position 1/2 in. drive breaker bar tool fully into square hole in arm of belt tensioner (Figure 1, Item 1).
2. Lift breaker bar tool to relieve tension on belt (Figure 1, Item 2).
3. With belt tension relieved, remove belt (Figure 1, Item 2) from alternator pulley (Figure 1, Item 3).
4. Lower breaker bar and remove from belt tensioner (Figure 1, Item 1) and vehicle.

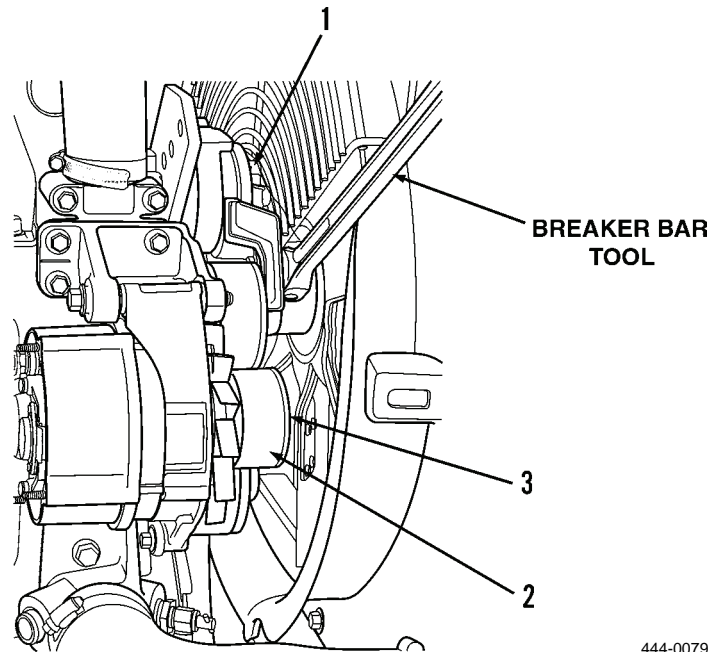
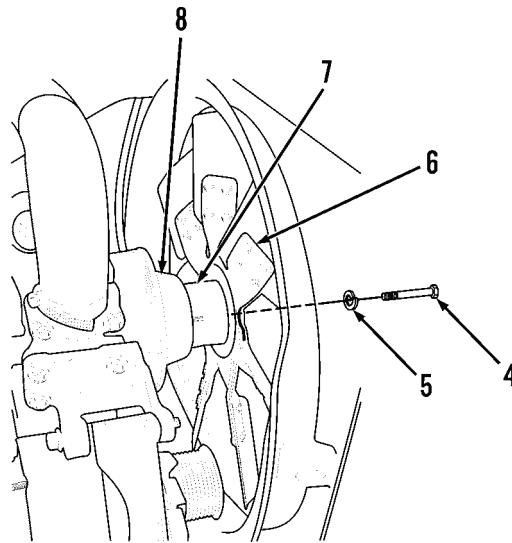

**Figure 1. Fan Belt and Belt Tensioner.**

**NOTE**

Belt tensioner has been removed for clarity in Figure 2.

5. Remove four capscrews (Figure 2, Item 4) and lockwashers (Figure 2, Item 5) from fan (Figure 2, Item 6). Discard lockwashers.
6. Remove fan (Figure 2, Item 6), spacer (Figure 2, Item 7), and fan pulley (Figure 2, Item 8) from fan pulley bracket assembly.

**REMOVAL - CONTINUED**

444-0080

**Figure 2. Fan Assembly.****END OF TASK****CLEANING****WARNING**

Solvent cleaning compound MIL-PRF-680 Type III is an environmentally compliant and low toxic material. However, it may be irritating to the eyes and skin. Use protective gloves and goggles. Use in well-ventilated areas. Keep away from open flames and other sources of ignition. Failure to do so may result in injury or death to personnel.

Use solvent cleaning compound to all parts. Dry thoroughly.

**END OF TASK****INSPECTION**

1. Inspect belt. Replace if cracked or worn.
2. Inspect fan. Replace if blades are cracked, bent, or broken.
3. Inspect spacer. Replace if cracked or damaged.
4. Inspect fan pulley. Replace if bent, cracked, or holes are damaged.

**END OF TASK**

**INSTALLATION/REPLACEMENT**

1. Position fan pulley (Figure 3, Item 8), spacer (Figure 3, Item 7), and fan (Figure 3, Item 6) on fan pulley bracket assembly.
2. Install four new lockwashers (Figure 3, Item 5) and capscrews (Figure 3, Item 4) on fan (Figure 3, Item 6). Tighten capscrews to 38 to 46 lb-ft (52 to 62 Nm).

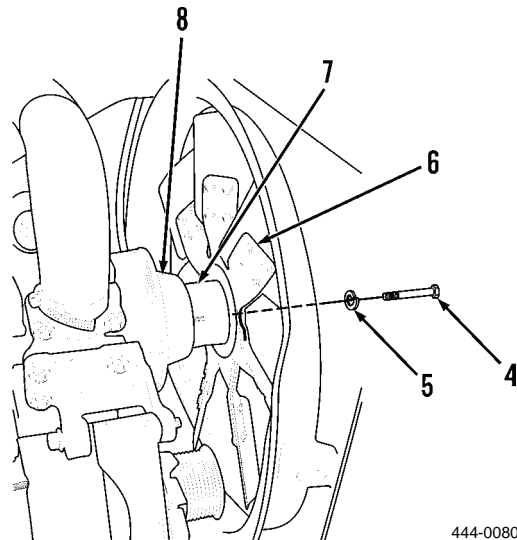
**Figure 3. Fan Assembly.**

3. Position belt (Figure 4, Item 2) on vehicle and place belt over fan and around all pulleys except alternator pulley (Figure 4, Item 3) and belt tensioner pulley.
4. Position 1/2 in. drive breaker bar tool fully into square hole in arm of belt tensioner (Figure 4, Item 1).
5. Lift breaker bar tool to raise pulley of belt tensioner (Figure 4, Item 1).
6. With pulley raised, install belt (Figure 4, Item 2) around alternator pulley (Figure 4, Item 3). Lower breaker bar and remove from belt tensioner (Figure 4, Item 1).

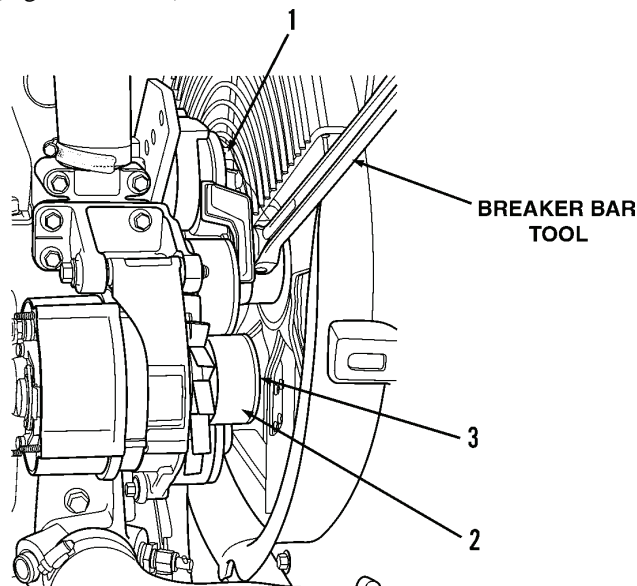
**Figure 4. Fan Belt and Belt Tensioner.****END OF TASK****END OF WORK PACKAGE**

---

## ORGANIZATIONAL MAINTENANCE INSTRUCTIONS

### FAN BELT TENSIONER REPLACEMENT (MODEL 4-390)

#### Removal, Installation/Replacement

---

#### INITIAL SETUP

**Maintenance Level**

Organizational

**Tools and Special Tools**

Tool kit, general mechanic's (Item 15, WP 0309)

Shop equipment, common no. 1 (Item 2, WP 0309)

**Materials/Parts**

Rag, wiping (Item 26, WP 0310)

**Equipment Condition**

Left side panel removed (WP 0179)

Left hood panel removed (WP 0183)

Belt removed (WP 0089)

Fan guard removed (WP 0083)

---

**REMOVAL**

1. Loosen bolt (Figure 1, Item 1) on belt tensioner (Figure 1, Item 2).
2. Remove belt tensioner (Figure 1, Item 2) and bolt (Figure 1, Item 1) from bracket (Figure 1, Item 3).

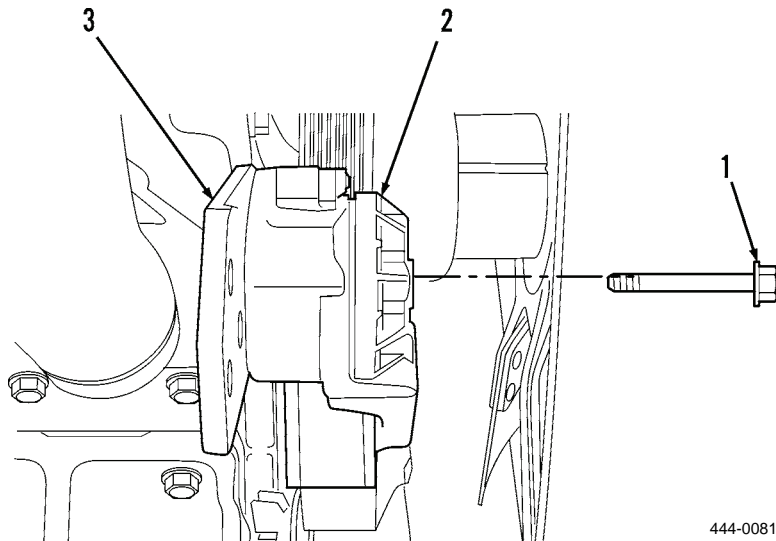
**Figure 1. Belt Tensioner.**

3. Remove capscrew (Figure 2, Item 4), socket head capscrew (Figure 2, Item 5), and bracket (Figure 2, Item 3) from engine cylinder head.

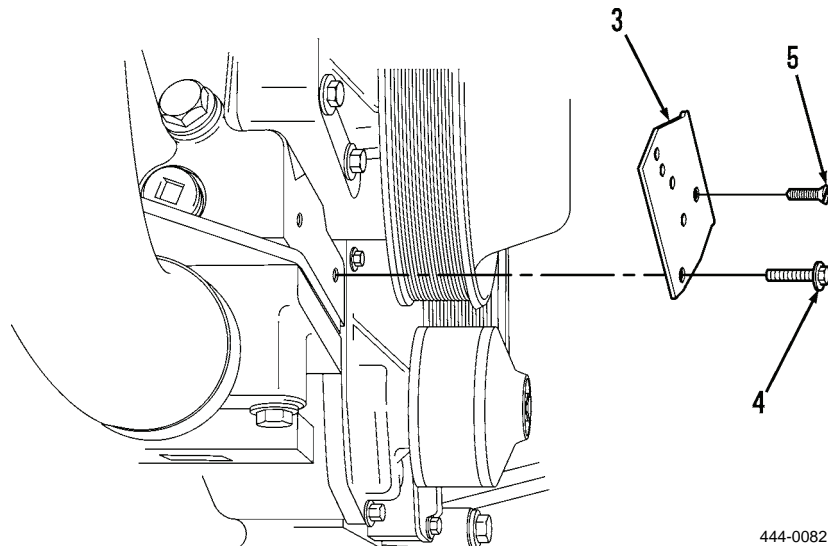
**Figure 2. Bracket Assembly.****END OF TASK****INSTALLATION/REPLACEMENT**

1. Install bracket (Figure 2, Item 3), socket head capscrew (Figure 2, Item 5), and capscrew (Figure 2, Item 4) on engine cylinder head. Tighten capscrews to 15 to 20 lb-ft (20 to 27 Nm).
2. Install belt tensioner (Figure 1, Item 2) and bolt (Figure 1, Item 1) on bracket (Figure 1, Item 3).
3. Tighten bolt (Figure 1, Item 1) to 29 to 35 lb-ft (39 to 47 Nm).

**END OF TASK****END OF WORK PACKAGE**

---

## ORGANIZATIONAL MAINTENANCE INSTRUCTIONS

### FAN PULLEY BRACKET MAINTENANCE (MODEL 4-390)

Removal, Disassembly, Cleaning, Inspection, Assembly, Installation

---

#### INITIAL SETUP

**Maintenance Level**

Organizational

**Tools and Special Tools**

Tool kit, general mechanic's (Item 15, WP 0309)

Shop equipment, common no. 1 (Item 2, WP 0309)

**Materials/Parts**

Cleaning compound, solvent (Item 10, WP 0310)

Rag, wiping (Item 26, WP 0310)

**Equipment Condition**

Belt removed (WP 0089)

---

**REMOVAL**

1. Remove four capscrews (Figure 1, Item 1) from fan pulley bracket assembly (Figure 1, Item 2).
2. Remove fan pulley bracket assembly (Figure 1, Item 2) from engine cylinder.

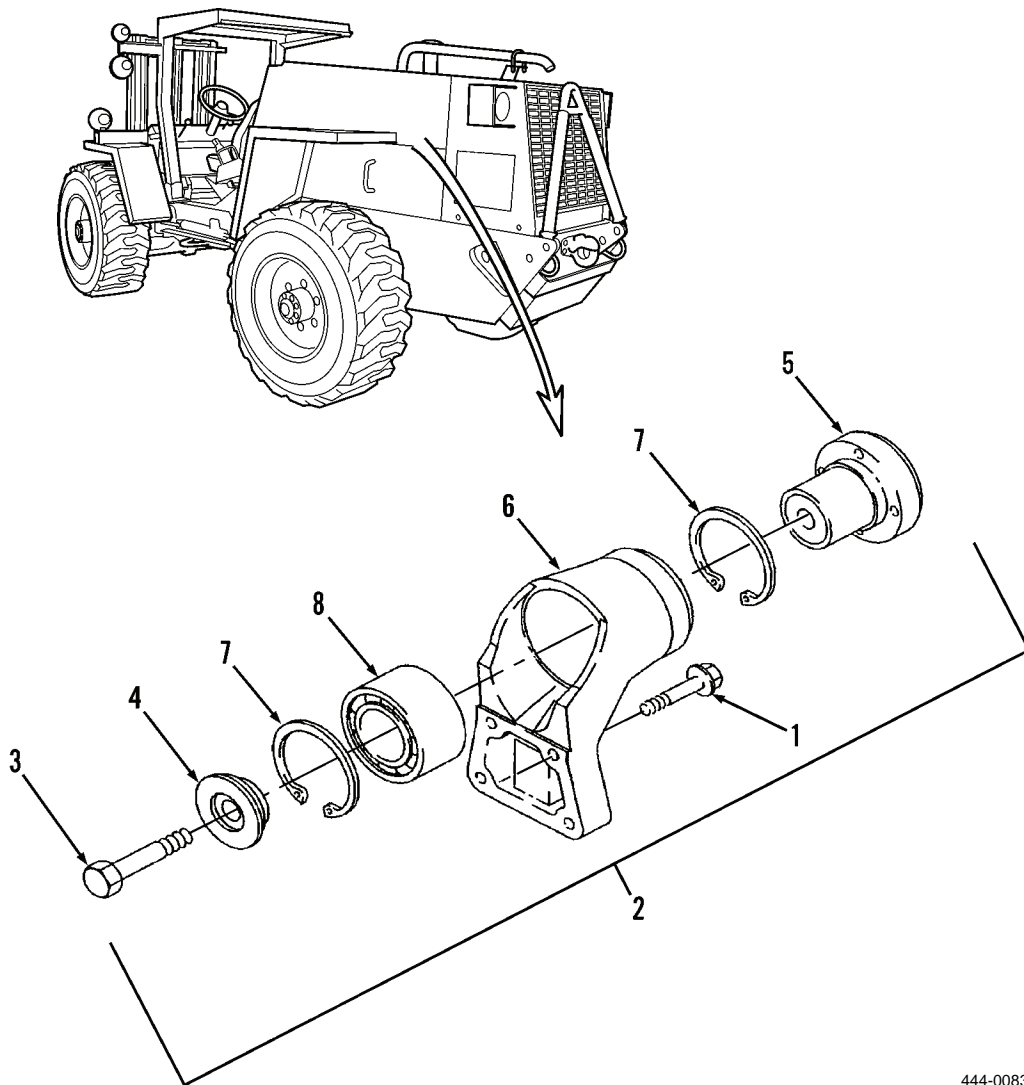

444-0083

**Figure 1. Fan Pulley Bracket Assembly.****END OF TASK****DISASSEMBLY**

1. Remove bolt (Figure 1, Item 3) from fan pulley bracket assembly (Figure 1, Item 2).
2. Remove retainer (Figure 1, Item 4) from bearing (Figure 1, Item 8).
3. Remove fan hub (Figure 1, Item 5) from fan support bracket (Figure 1, Item 6).
4. Remove fan support bracket (Figure 1, Item 6) and two retaining rings (Figure 1, Item 7) from fan bracket assembly (Figure 1, Item 2).
5. Remove bearing (Figure 1, Item 8) by pressing out of fan support bracket (Figure 1, Item 6).

**END OF TASK**



**CLEANING****WARNING**

Solvent cleaning compound MIL-PRF-680 Type III is an environmentally compliant and low toxic material. However, it may be irritating to the eyes and skin. Use protective gloves and goggles. Use in well-ventilated areas. Keep away from open flames and other sources of ignition. Failure to do so may result in injury or death to personnel.

Use solvent cleaning compound to clean all parts. Dry thoroughly.

**END OF TASK****INSPECTION**

1. Inspect bearing. Replace bearing if inner race to outer race is seized, rotates roughly, or there is excessive play.
2. Inspect all other parts. Replace if cracked, damaged, broken, or threads are worn.

**END OF TASK****ASSEMBLY**

1. Install one of two retaining rings (Figure 1, Item 7) on fan support bracket (Figure 1, Item 6).
2. Install bearing (Figure 1, Item 8) on fan pulley bracket assembly (Figure 1, Item 2).
3. Install other retaining ring (Figure 1, Item 7) on fan pulley bracket assembly (Figure 1, Item 2).
4. Install fan hub (Figure 1, Item 5) on fan support bracket (Figure 1, Item 6).
5. Position retainer (Figure 1, Item 4) on bearing (Figure 1, Item 8).
6. Install bolt (Figure 1, Item 3) on fan pulley bracket assembly (Figure 1, Item 2). Tighten bolt to 18 to 22 lb-ft (24 to 30 Nm) torque.

**END OF TASK****INSTALLATION/REPLACEMENT**

1. Position fan pulley bracket assembly (Figure 1, Item 2) on engine cylinder head.
2. Install four capscrews (Figure 1, Item 1) on fan support bracket (Figure 1, Item 6). Tighten capscrews to 17 to 18 lb-ft (23 to 24 Nm).

**END OF TASK****END OF WORK PACKAGE**



---

## ORGANIZATIONAL MAINTENANCE INSTRUCTIONS

### COOLANT INLET MANIFOLD REPLACEMENT (MODEL 4-390)

#### Removal, Installation/Replacement

---

#### INITIAL SETUP

**Maintenance Level**

Organizational

**Tools and Special Tools**

Tool kit, general mechanic's (Item 15, WP 0309)

Shop equipment, common no. 1 (Item 2, WP 0309)

**Materials/Parts**

Rag, wiping (Item 26, WP 0310)

O-ring

**Equipment Condition**

Left and right side panels removed (WP 0179)

Radiator drained (WP 0079)

Lower radiator hose removed (WP 0081)

---

**REMOVAL**

1. Remove capscrew (Figure 1, Item 1) from alternator and coolant inlet manifold (Figure 1, Item 3).
2. Remove three capscrews (Figure 1, Item 2) from coolant inlet manifold (Figure 1, Item 3).
3. Remove coolant inlet manifold (Figure 1, Item 3) from engine.
4. Remove O-ring (Figure 1, Item 4) from engine. Discard O-ring.
5. Disconnect drain hose (Figure 1, Item 5) from drain valve (Figure 1, Item 6).
6. Remove drain valve (Figure 1, Item 6) from adapter (Figure 1, Item 7).
7. Remove adapter (Figure 1, Item 7) from coolant inlet manifold (Figure 1, Item 3).
8. Remove plug (Figure 1, Item 8) from coolant inlet manifold (Figure 1, Item 3).

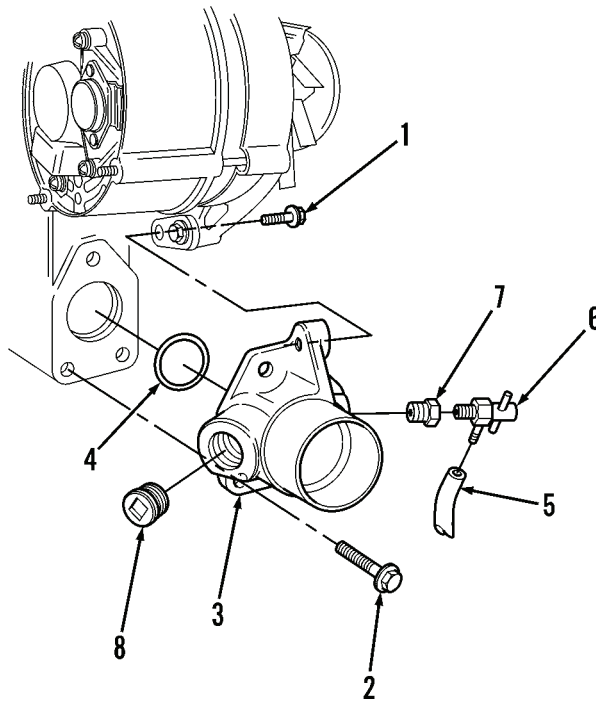

444-0085

**Figure 1. Coolant Inlet Manifold Assembly.****END OF TASK**

---

**INSTALLATION/REPLACEMENT**

1. Install plug (Figure 1, Item 8) on coolant inlet manifold (Figure 1, Item 3).
2. Install adapter (Figure 1, Item 7) on coolant inlet manifold (Figure 1, Item 3).
3. Install drain valve (Figure 1, Item 6) on adapter (Figure 1, Item 7).
4. Connect drain hose (Figure 1, Item 5) to drain valve (Figure 1, Item 6).
5. Install new O-ring (Figure 1, Item 4) on engine.
6. Position coolant inlet manifold (Figure 1, Item 3) on engine and install three capscrews (Figure 1, Item 2). Tighten capscrews to 29 to 35 lb-ft (39 to 47 Nm).
7. Install capscrew (Figure 1, Item 1) on alternator and coolant inlet manifold (Figure 1, Item 3). Tighten capscrew to 18 lb-ft (24 Nm).

**END OF TASK****END OF WORK PACKAGE**



---

## ORGANIZATIONAL MAINTENANCE INSTRUCTIONS

### ALTERNATOR MAINTENANCE (MODEL 207)

#### Removal, Cleaning, Inspection, Installation/Replacement, Testing

---

#### INITIAL SETUP

##### Maintenance Level

Organizational

##### Tools and Special Tools

Tool kit, general mechanic's (Item 15, WP 0309)

Shop equipment, common no. 1 (Item 2, WP 0309)

##### Materials/Parts

Cleaning compound, solvent (Item 10, WP 0310)

Rag, wiping (Item 26, WP 0310)

##### Materials/Parts - Continued

RTV sealant (Item 31, WP 0310)

Strap, tiedown (Item 32, WP 0310)

Lockwasher (6)

##### Equipment Condition

Engine OFF

Left side panel removed (WP 0179)

Alternator and fan belt removed (WP 0088)

Battery ground cable disconnected (WP 0133)

---

---

**REMOVAL**

1. Remove nut (Figure 1, Item 1), lockwasher (Figure 1, Item 2), and wire lead (Figure 1, Item 3) from BAT terminal. Discard lockwasher.
2. Disconnect push-on connector (Figure 1, Item 4) from terminals 1, 2, and R.
3. Remove capscrew (Figure 1, Item 5), lockwasher (Figure 1, Item 6), and washer (Figure 1, Item 7) from strap (Figure 1, Item 18). Discard lockwasher.
4. Support alternator (Figure 1, Item 11) and remove nut (Figure 1, Item 8), lockwasher (Figure 1, Item 9), and capscrew (Figure 1, Item 10) from bracket (Figure 1, Item 22). Discard lockwasher.
5. Remove alternator (Figure 1, Item 11) from vehicle.
6. Use pulley puller to remove nut (Figure 1, Item 12), lockwasher (Figure 1, Item 13), pulley (Figure 1, Item 14), and fan (Figure 1, Item 15) from alternator (Figure 1, Item 11). Discard lockwasher.
7. Remove capscrew (Figure 1, Item 16), lockwasher (Figure 1, Item 17), strap (Figure 1, Item 18), and spacer (Figure 1, Item 19) from engine. Discard lockwasher.
8. Remove capscrew (Figure 1, Item 20), lockwasher (Figure 1, Item 21), and bracket (Figure 1, Item 22) from engine. Discard lockwasher.
9. Push together, turn, and separate retainer halves (Figure 1, Item 23) and remove resistor (Figure 1, Item 24).
10. Cut and remove tiedown strap (Figure 1, Item 25) from harness and diode (Figure 1, Item 26).
11. Unplug and remove diode (Figure 1, Item 26).



REMOVAL - CONTINUED

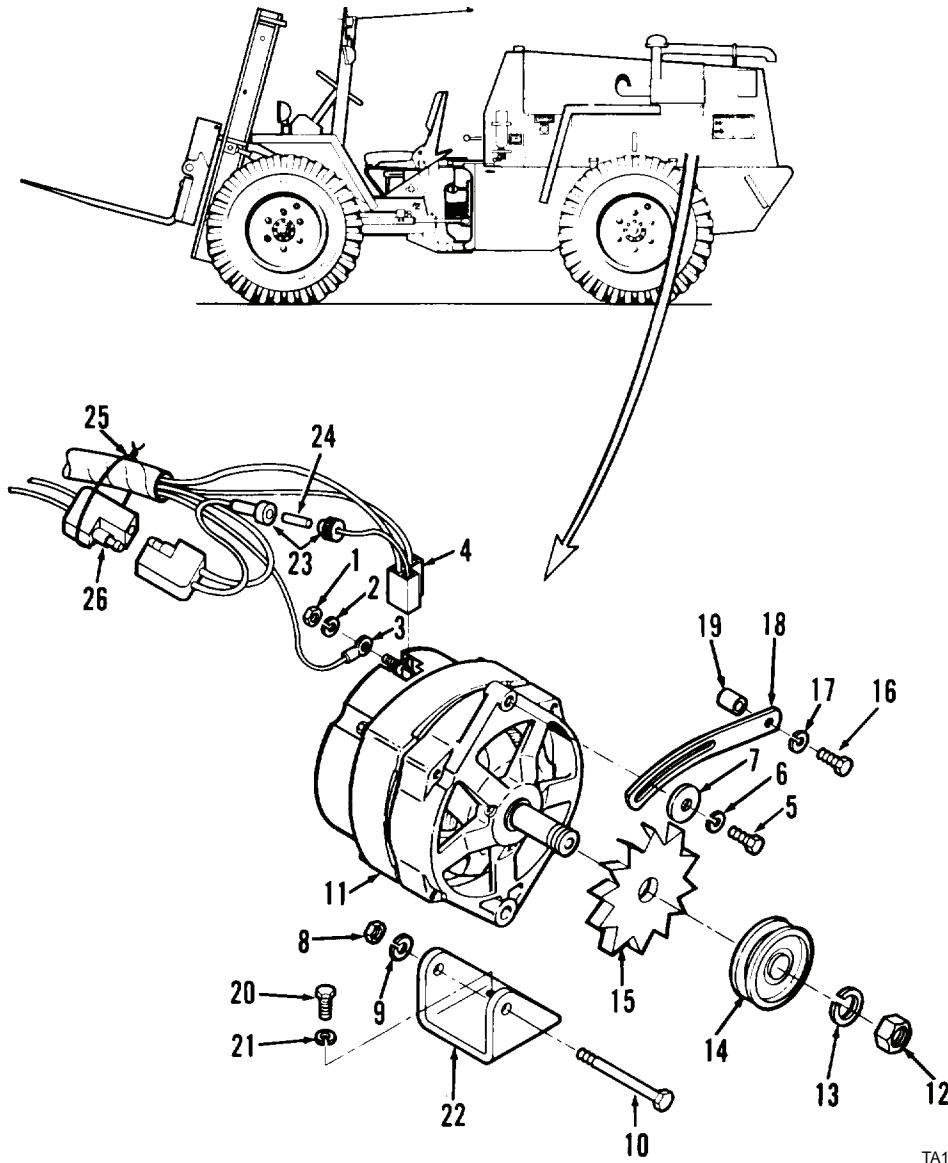

Figure 1. Alternator Assembly.

TA126921

END OF TASK

**CLEANING****WARNING**

- Solvent cleaning compound MIL-PRF-680 Type III is an environmentally compliant and low toxic material. However, it may be irritating to the eyes and skin. Use protective gloves and goggles. Use in well-ventilated areas. Keep away from open flames and other sources of ignition. Failure to do so may result in injury or death to personnel.
  - Particles blown by compressed air are hazardous. DO NOT exceed 15 PSI (103 kPa) nozzle pressure when drying parts with compressed air. DO NOT direct compressed air against human skin. Make sure air stream is directed away from user and other personnel in the area. To prevent injury, user must wear protective goggles or face shield. Failure to follow this warning may result in injury to personnel.
1. Use solvent cleaning compound and stiff bristled brush to clean pulley (Figure 2, Item 14), fan (Figure 2, Item 15), strap (Figure 2, Item 18), and bracket (Figure 2, Item 22). Dry thoroughly with compressed air
  2. Use solvent cleaning compound to clean all hardware. Dry thoroughly with compressed air.

**END OF TASK****INSPECTION**

1. Inspect fan (Figure 2, Item 15). Replace if cracked or damaged, or if fins bent or broken.
2. Inspect pulley (Figure 2, Item 14), strap (Figure 2, Item 18), and bracket (Figure 2, Item 22). Replace if cracked, damaged, or worn.
3. Inspect all hardware. Replace if worn, or if threads damaged.
4. Set ohmmeter to lowest resistance range, and connect leads to terminals of diode (Figure 2, Item 26). Note reading, then reverse leads and note reading. There should be one low and one high reading. Replace diode if readings are both low, both high, or identical.

**END OF TASK****INSTALLATION/REPLACEMENT**

1. Position fan (Figure 2, Item 15) and pulley (Figure 2, Item 14) on shaft of alternator.
2. Install new lockwasher (Figure 2, Item 13) and nut (Figure 2, Item 12) and tighten nut to 40 to 60 lb-ft (54 to 81 Nm).
3. Plug in diode (Figure 2, Item 26). Install new tiedown strap (Figure 2, Item 25) around harness and diode.
4. Position bracket (Figure 2, Item 22) on engine.
5. Install new lockwasher (Figure 2, Item 21) and capscrew (Figure 2, Item 20) on bracket (Figure 2, Item 22) and tighten capscrew.
6. Position spacer (Figure 2, Item 19) and strap (Figure 2, Item 18) on engine.
7. Install new lockwasher (Figure 2, Item 17) and capscrew (Figure 2, Item 16) hand-tight.
8. Position alternator (Figure 2, Item 11) on bracket (Figure 2, Item 22).
9. Install capscrew (Figure 2, Item 10), new lockwasher (Figure 2, Item 9), and nut (Figure 2, Item 8) in bracket (Figure 2, Item 22) hand-tight.
10. Install capscrew (Figure 2, Item 5), new lockwasher (Figure 2, Item 6), and washer (Figure 2, Item 7) hand-tight.

**INSTALLATION/REPLACEMENT - CONTINUED**

11. Install and adjust alternator and fan belt (WP 0088).
12. Tighten capscrew (Figure 2, Item 5), nut (Figure 2, Item 8), and capscrew (Figure 2, Item 16) when proper adjustment of alternator and fan belt is obtained.
13. Install wire lead (Figure 2, Item 3), new lockwasher (Figure 2, Item 2), and nut (Figure 1, Item 1) on BAT terminal of alternator.
14. Connect push-on connector (Figure 2, Item 4) to alternator terminals 1, 2, and R.
15. Use silicone rubber sealer to seal BAT terminal of alternator.
16. Position resistor (Figure 2, Item 24) in retainer halves (Figure 2, Item 23).
17. To secure resistor (Figure 2, Item 24), push retainer halves (Figure 2, Item 23) together and turn clockwise.

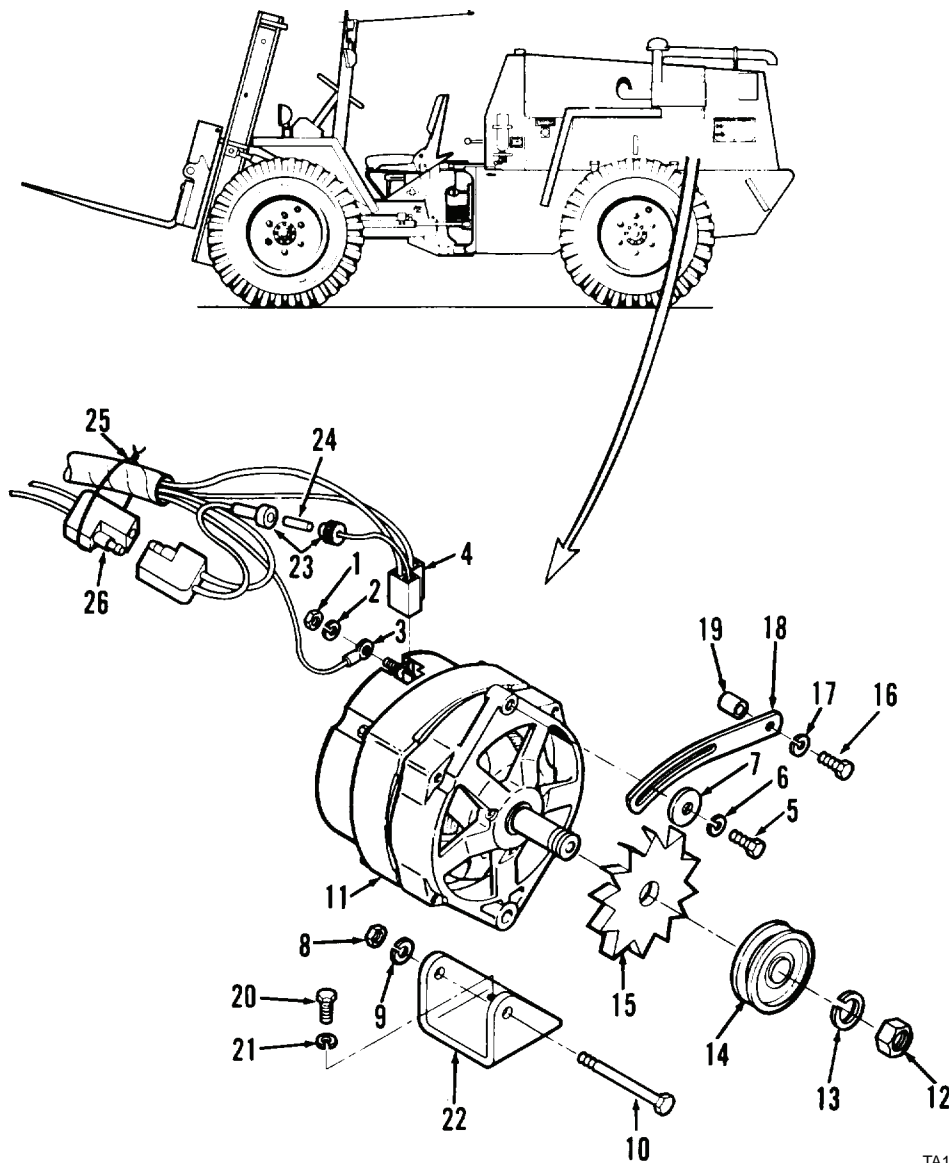

TA126921

Figure 2. Alternator Assembly.

**END OF TASK**

**TESTING**

1. Connect voltmeter to alternator BAT terminal and case ground (Figure 3).

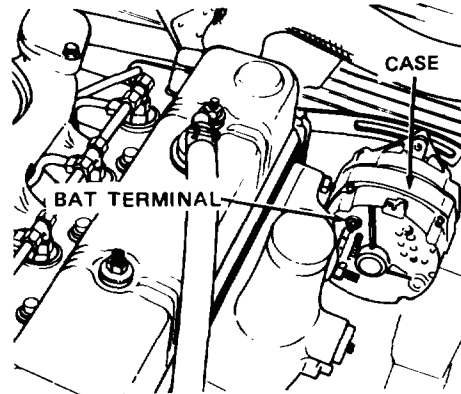

TA126896

**Figure 3. BAT Terminal and Case Ground.**

2. Place ignition switch in ON position.
3. Depress start switch and start engine. Operate engine at 1,800 RPM with all accessories off.
4. Observe voltmeter. Voltmeter should indicate no more than 31 VDC with engine operating at 1,800 RPM; if indication is more than 31 VDC, replace alternator.
5. Place ignition switch in OFF position.
6. Disconnect battery ground cable (WP 0133).
7. Connect ammeter between alternator BAT terminal and starter relay terminal 3.
8. Connect battery ground cable (WP 0133).
9. Connect carbon pile across batteries.
10. Place ignition switch in ON position.
11. Depress start switch. Start and operate engine at 1,800 RPM; turn all vehicle lights on to increase load on batteries.
12. Observe ammeter. Ammeter should indicate 27 to 47 amperes with engine operating at 1,800 RPM; if ammeter does not indicate 27 to 40 amperes, replace alternator.
13. Place ignition switch in OFF position. Turn all vehicle lights off.
14. Disconnect battery ground cable (WP 0133).
15. Disconnect carbon pile from batteries.
16. Disconnect ammeter.
17. Connect battery ground cable (WP 0133).

**END OF TASK****END OF WORK PACKAGE**

---

## ORGANIZATIONAL MAINTENANCE INSTRUCTIONS

### ALTERNATOR MAINTENANCE (MODEL 4-390)

#### Removal, Cleaning, Inspection, Installation, Testing

---

#### INITIAL SETUP

**Maintenance Level**

Organizational

**Tools and Special Tools**

Tool kit, general mechanic's (Item 15, WP 0309)

Shop equipment, common no. 1 (Item 2, WP 0309)

**Materials/Parts**

Brush, wire (Item 8, WP 0310)

**Materials/Parts - Continued**

Cleaning compound, solvent (Item 10, WP 0310)

Rag, wiping (Item 26, WP 0310)

Strap, tiedown (Item 32, WP 0310)

Lockwasher (3)

**Equipment Condition**

Battery ground cable disconnected (WP 0134)

Belt removed (WP 0089)

---

## REMOVAL

1. At left rear of engine compartment, remove nut (Figure 1, Item 1), lockwasher (Figure 1, Item 2), and wire lead (Figure 1, Item 3) from BAT terminal of alternator (Figure 1, Item 4). Discard lockwasher.
2. Remove nut (Figure 1, Item 5), lockwasher (Figure 1, Item 6), and wire lead (Figure 1, Item 7) from terminal D of alternator (Figure 1, Item 4). Discard lockwasher.
3. Remove two capscrews (Figure 1, Item 8) and link (Figure 1, Item 9) from between bottom of alternator (Figure 1, Item 4) and engine coolant adapter.
4. While supporting alternator (Figure 1, Item 4), remove bolt (Figure 1, Item 10) and alternator from alternator bracket (Figure 1, Item 11).
5. Remove three capscrews (Figure 1, Item 12) and alternator bracket (Figure 1, Item 11) from engine thermostat housing.
6. Remove bushing (Figure 1, Item 13) from alternator bracket (Figure 1, Item 11).
7. Remove nut (Figure 1, Item 14), lockwasher (Figure 1, Item 15), pulley (Figure 1, Item 16), and fan (Figure 1, Item 17) from shaft of alternator (Figure 1, Item 4). Use pulley puller to remove pulley. Discard lockwasher.
8. Separate halves of connector (Figure 1, Item 18) by lifting lever and pulling apart.
9. Disconnect and remove diode (Figure 1, Item 19) from connector (Figure 1, Item 20).
10. Cut and discard tiedown strap (Figure 1, Item 21).
11. Separate in-line retainer (Figure 1, Item 22) by pushing together, turning, and pulling apart.
12. Remove resistor (Figure 1, Item 23) from in-line retainer (Figure 1, Item 22) halves.

## END OF TASK

## CLEANING



### WARNING

- Solvent cleaning compound MIL-PRF-680 Type III is an environmentally compliant and low toxic material. However, it may be irritating to the eyes and skin. Use protective gloves and goggles. Use in well-ventilated areas. Keep away from open flames and other sources of ignition. Failure to do so may result in injury or death to personnel.
  - Particles blown by compressed air are hazardous. DO NOT exceed 15 PSI (103 kPa) nozzle pressure when drying parts with compressed air. DO NOT direct compressed air against human skin. Make sure air stream is directed away from user and other personnel in the area. To prevent injury, user must wear protective goggles or face shield. Failure to follow this warning may result in injury to personnel.
1. Clean link (Figure 1, Item 9), alternator bracket (Figure 1, Item 11), pulley (Figure 1, Item 16), and fan (Figure 1, Item 17). Use solvent cleaning compound and stiff bristle brush. Dry thoroughly with compressed air.
  2. Clean all hardware with solvent cleaning compound. Dry thoroughly with compressed air.

CLEANING - CONTINUED

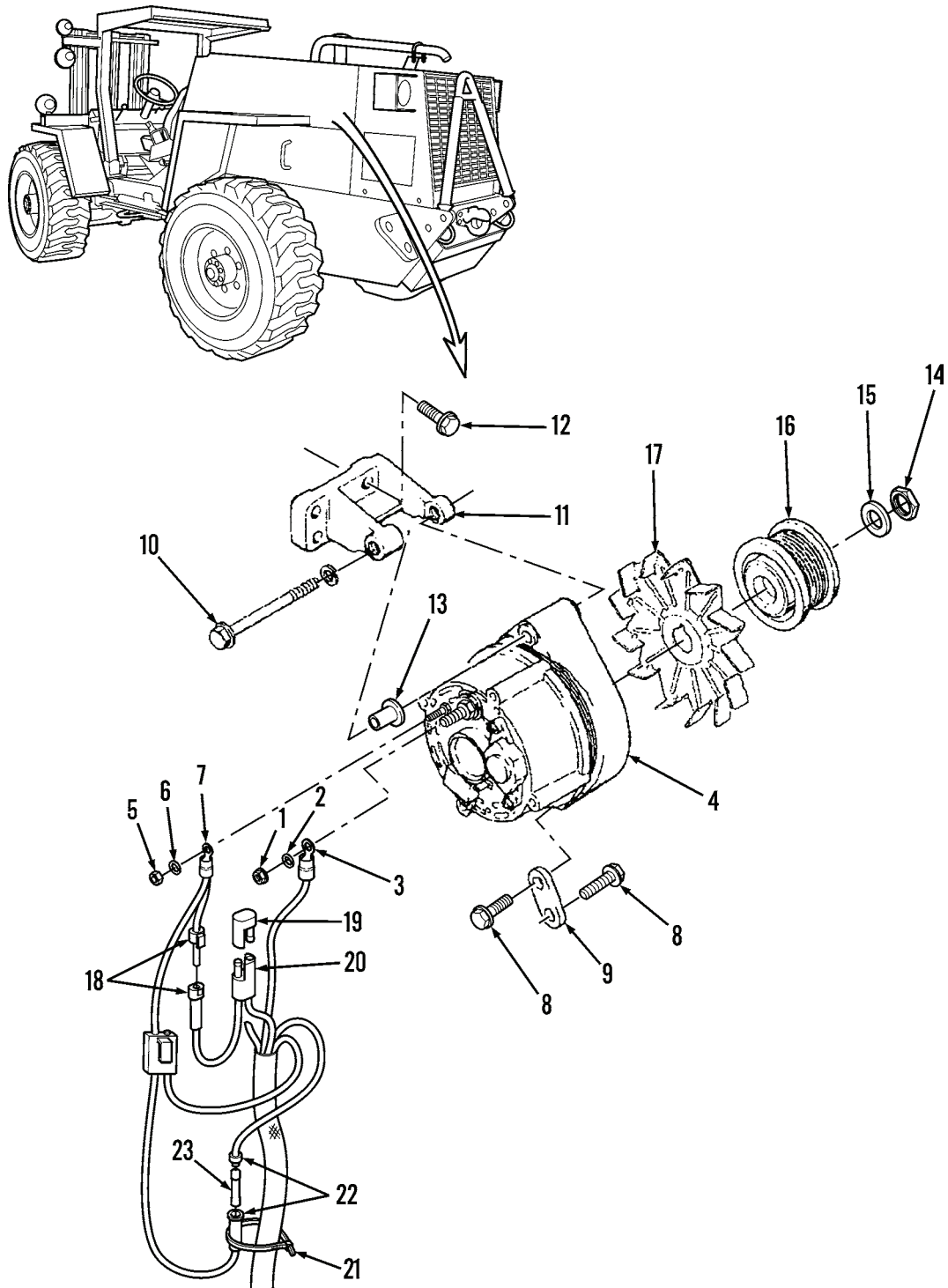

444-0099

Figure 1. Alternator.

END OF TASK

---

**INSPECTION**

1. Inspect fan (Figure 2, Item 17). Replace if cracked or damaged, or if fins are bent or broken.
2. Inspect pulley (Figure 2, Item 16), alternator bracket (Figure 2, Item 11), bushing (Figure 2, Item 13), and link (Figure 2, Item 9). Replace if cracked, damaged, or worn.
3. Inspect all hardware. Replace if worn, or if threads are damaged.
4. Test diode (Figure 2, Item 19). Set ohmmeter to lowest resistance range and connect leads to terminals of diode. Note reading, then reverse leads and note reading. There should be one low, and one high reading. Replace diode if readings are both low, both high, or identical.

**END OF TASK****INSTALLATION**

1. Position resistor (Figure 2, Item 23) into in-line retainer (Figure 2, Item 22) halves.
2. Connect in-line retainer (Figure 2, Item 22) halves, push together, turn, and release.
3. Install new tiedown strap (Figure 2, Item 21) around retainer (Figure 2, Item 22) and harness.
4. Connect diode (Figure 2, Item 19) to connector (Figure 2, Item 20).
5. Connect connector (Figure 2, Item 18) halves by aligning halves and pushing together.
6. Install fan (Figure 2, Item 17), pulley (Figure 2, Item 16), new lockwasher (Figure 2, Item 15), and nut (Figure 2, Item 14) on shaft of alternator (Figure 2, Item 4). Tighten nut to 40 to 60 lb-ft (54 to 81 Nm).
7. Install bushing (Figure 2, Item 13) on alternator bracket (Figure 2, Item 11).
8. Install alternator bracket (Figure 2, Item 11) on engine thermostat housing with three capscrews (Figure 2, Item 12). Tighten capscrews to 15 to 20 lb-ft (20 to 27 Nm).
9. Position alternator (Figure 2, Item 4) on alternator bracket (Figure 2, Item 11) and loosely install bolt (Figure 2, Item 10) to support alternator.
10. Install link (Figure 2, Item 9) and two capscrews (Figure 2, Item 8) between bottom of alternator (Figure 2, Item 4) and engine coolant adapter. Tighten capscrews to 18 lb-ft (24 Nm). Tighten bolt (Figure 2, Item 10) to 32 lb-ft (43 Nm).
11. Install wire lead (Figure 2, Item 7) on terminal D of alternator (Figure 2, Item 4) with new lockwasher (Figure 2, Item 6) and nut (Figure 2, Item 5).
12. Install wire lead (Figure 2, Item 3) on BAT terminal of alternator (Figure 2, Item 4) with new lockwasher (Figure 2, Item 2) and nut (Figure 2, Item 1).



INSTALLATION - CONTINUED

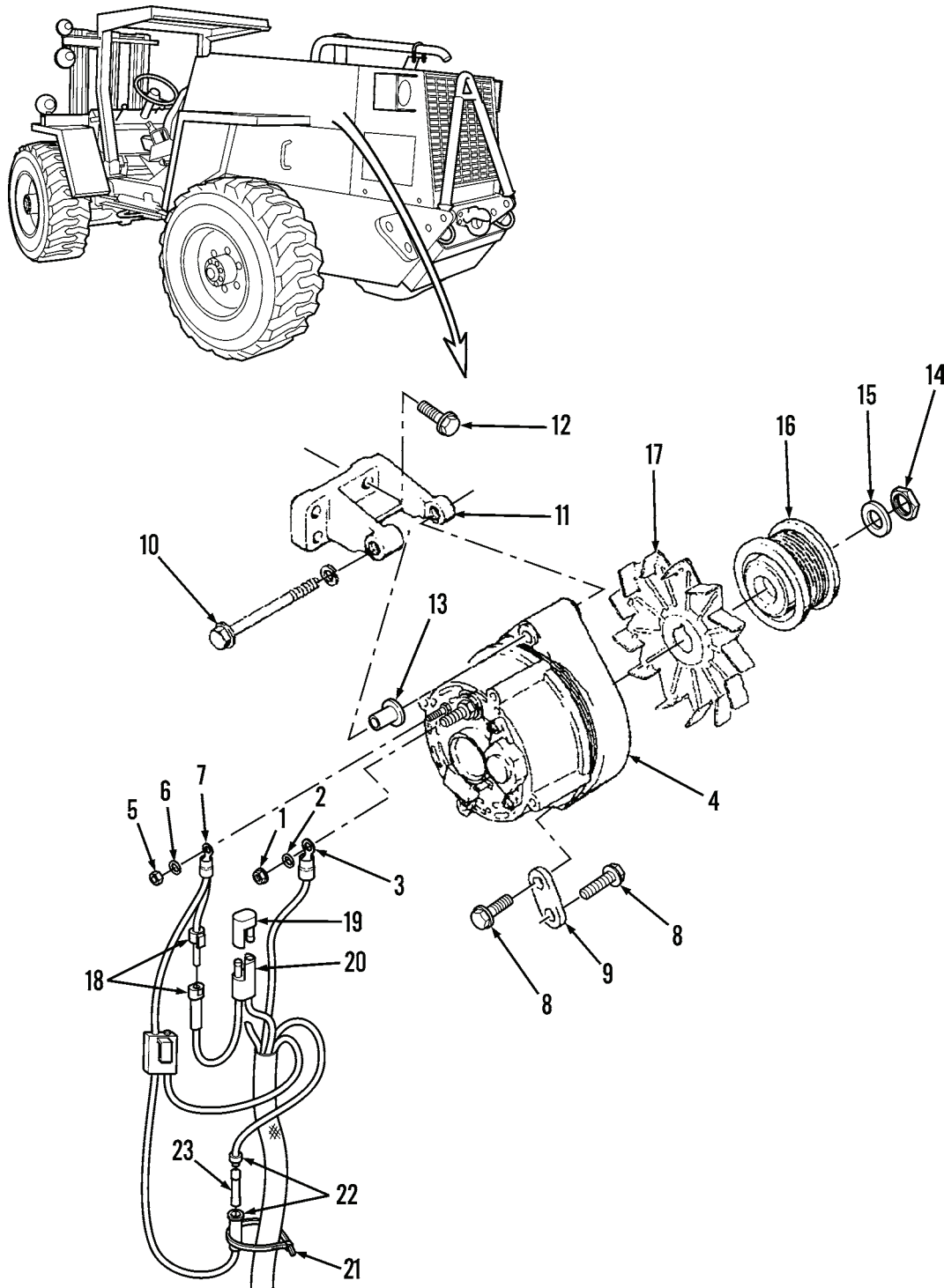

444-0099

Figure 2. Alternator.

END OF TASK

**TESTING**

1. At left rear of engine compartment, connect wire leads of voltmeter to alternator (Figure 2, Item 4) BAT terminal and case ground (Figure 3).

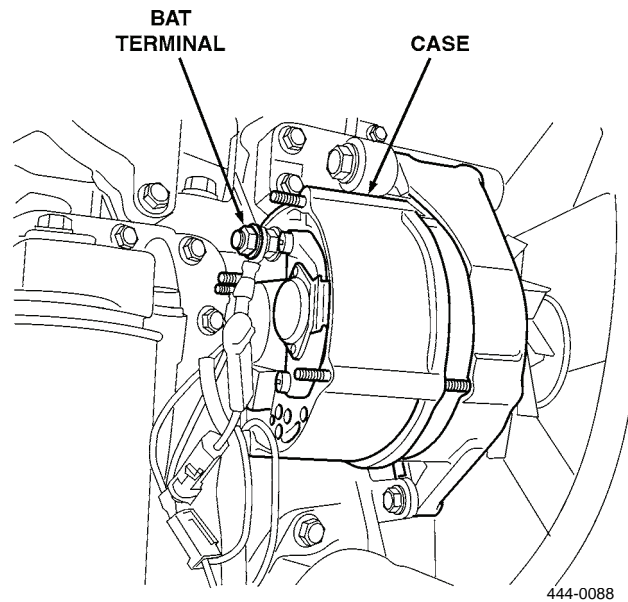

**Figure 3. Alternator Testing.**

2. In operator's compartment, place ignition switch in ON position.
3. Depress start switch and start engine. Operate engine at 1,800 RPM with all accessories off.
4. Observe voltmeter. Voltmeter should indicate no more than 31 VDC with engine operating at 1,800 RPM; if indication is more than 31 VDC, replace alternator.
5. Place ignition switch in OFF position.
6. In battery compartment at rear of vehicle, disconnect battery ground cable (WP 0134).
7. In engine compartment, connect ammeter between alternator (Figure 2, Item 4) BAT terminal and starter relay terminal 3.
8. In battery compartment at rear of vehicle, connect battery ground cable (WP 0134).
9. Connect a carbon pile across batteries.
10. Place ignition switch in ON position.
11. Depress start switch and start engine. Operate engine at 1,800 RPM. Turn all vehicle lights on to increase load on batteries.
12. Observe ammeter. Ammeter should indicate 27 to 47 amperes with engine operating at 1,800 RPM; if ammeter does not indicate 27 to 40 amperes, replace alternator.
13. Place ignition switch in OFF position. Turn all vehicle lights off.
14. In battery compartment at rear of vehicle, disconnect battery ground cable (WP 0134).
15. Disconnect carbon pile from batteries.
16. In engine compartment, disconnect ammeter.
17. In battery compartment at rear of vehicle, connect battery ground cable (WP 0134).

**END OF TASK****END OF WORK PACKAGE**

---

# ORGANIZATIONAL MAINTENANCE INSTRUCTIONS

## STARTER MAINTENANCE (MODEL 207)

Removal, Cleaning, Inspection, Testing, Installation/Replacement

---

### INITIAL SETUP

#### Maintenance Level

Organizational

#### Tools and Special Tools

Tool kit, general mechanic's (Item 15, WP 0309)

Shop equipment, common no. 1 (Item 2, WP 0309)

#### Materials/Parts

Cleaning compound, solvent (Item 10, WP 0310)

#### Materials/Parts - Continued

Rag, wiping (Item 26, WP 0310)

RTV sealant (Item 31, WP 0310)

Lockwasher (5)

#### Equipment Condition

Engine OFF

Left side panel removed (WP 0179)

Battery ground cable disconnected (WP 0133)

---

**REMOVAL**

1. Remove nut (Figure 1, Item 1), lockwasher (Figure 1, Item 2), and wire (Figure 1, Item 3) from solenoid switch S terminal. Discard lockwasher.
2. Remove nut (Figure 1, Item 4), lockwasher (Figure 1, Item 5), two cables (Figure 1, Items 6 and 7) and wire (Figure 1, Item 8) from solenoid switch B terminal. Discard lockwasher.
3. Support starter (Figure 1, Item 12) and remove three capscrews (Figure 1, Item 9), lockwashers (Figure 1, Item 10), and ground cable (Figure 1, Item 11). Discard lockwashers.
4. Remove starter (Figure 1, Item 12) from engine.

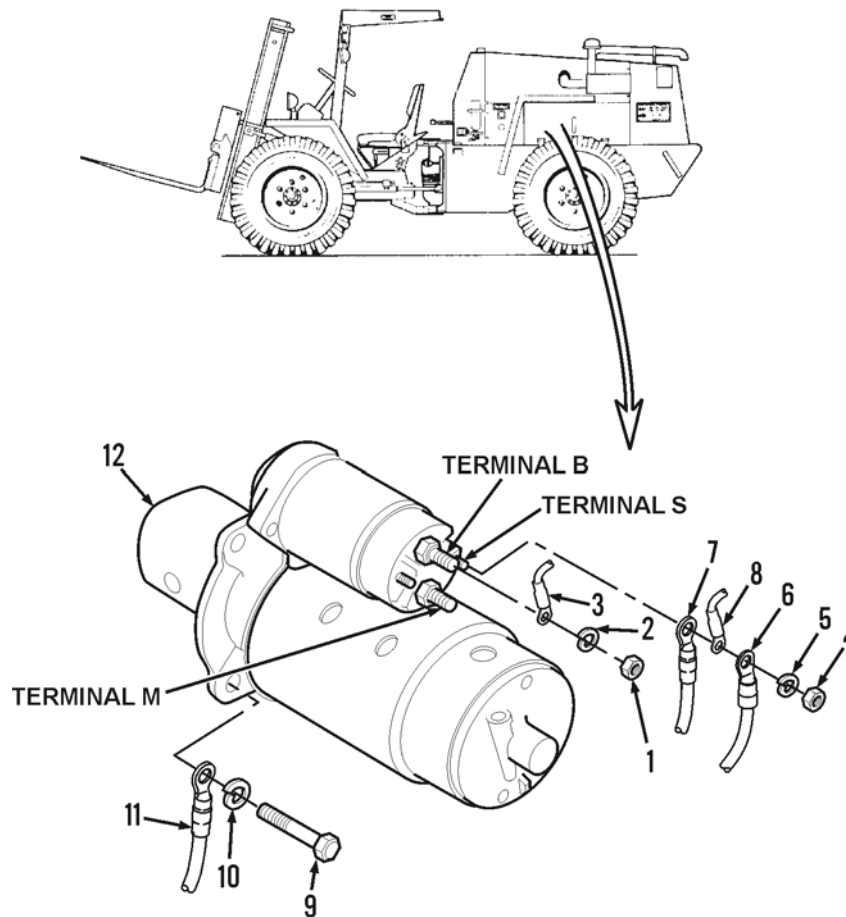

444-1056

**Figure 1. Starter.****END OF TASK****CLEANING**

1. Wipe exterior of starter (Figure 1, Item 12) with clean, dry cloth.

**CLEANING - CONTINUED****WARNING**

- Solvent cleaning compound MIL-PRF-680 Type III is an environmentally compliant and low toxic material. However, it may be irritating to the eyes and skin. Use protective gloves and goggles. Use in well-ventilated areas. Keep away from open flames and other sources of ignition. Failure to do so may result in injury or death to personnel.
  - Particles blown by compressed air are hazardous. DO NOT exceed 15 PSI (103 kPa) nozzle pressure when drying parts with compressed air. DO NOT direct compressed air against human skin. Make sure air stream is directed away from user and other personnel in the area. To prevent injury, user must wear protective goggles or face shield. Failure to follow this warning may result in injury to personnel.
2. Wipe wires (Figure 1, Items 3 and 8) and cables (Figure 1, Items 6, 7, and 11) with clean, dry rags. Use solvent cleaning compound on connectors only.
  3. Use solvent cleaning compound to clean all hardware. Dry thoroughly with compressed air.

**END OF TASK****INSPECTION**

1. Inspect all hardware. Replace if worn, or if threads damaged.
2. Inspect wires (Figure 1, Items 3 and 8) and cables (Figure 1, Items 6, 7, and 11). Replace if insulation frayed, or if conductors broken.
3. Inspect starter (Figure 1, Item 12). Replace if pinion gear teeth chipped, damaged, or excessively worn (Figure 2).

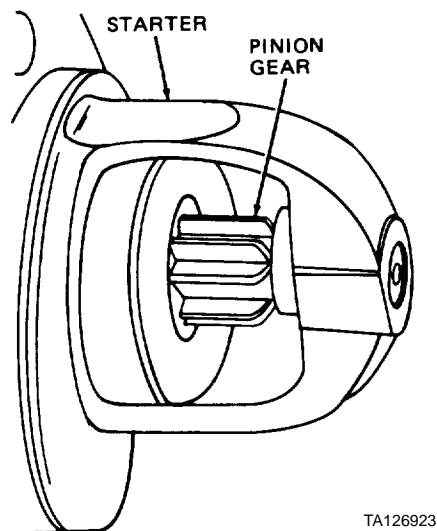
**Figure 2. Starter Inspection.****END OF TASK**

**TESTING**

1. With starter on test bench, connect starter to test setup as shown (Figure 3).

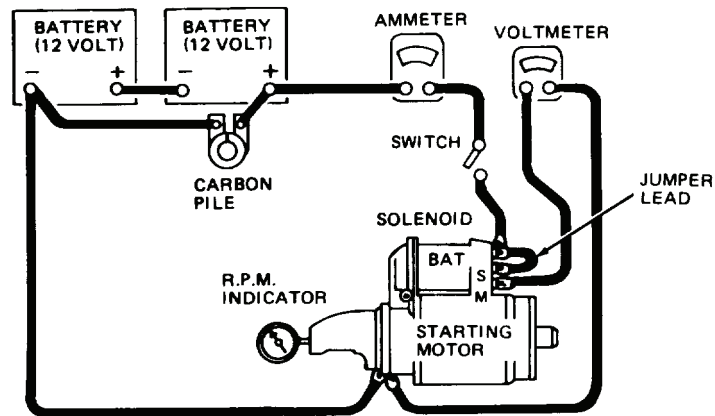

TA126898

**Figure 3. Starter Testing.**

2. Adjust carbon pile for 20 VDC indication on voltmeter.
3. Ammeter should indicate 52 to 90 amperes.
4. RPM indicator should indicate 8,000 to 13,000 RPM.

**NOTE**

If ammeter does not indicate 52 to 90 amperes, or RPM indicator does not indicate 8,000 to 13,000 RPM, record voltage, current, and RPM, and forward test results with defective starter to direct support maintenance. If ammeter indicates 52 to 90 amperes and RPM indicator indicates 8,000 to 13,000 RPM, proceed to step 5.

5. Disconnect starter from test setup.
6. Disconnect and tape field coil lead at solenoid M terminal.
7. Connect solenoid terminals to test setup as shown (Figure 4).

## TESTING - CONTINUED

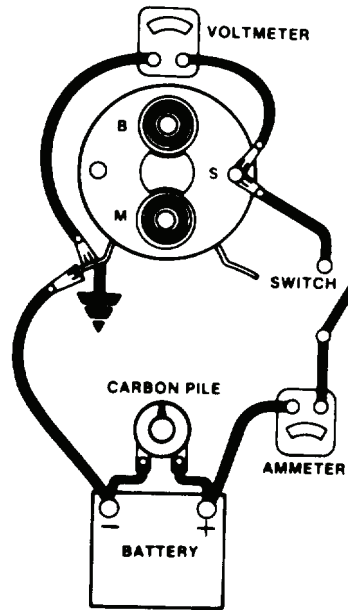

TA127132

**Figure 4. Starter Solenoid Switch Testing.**

8. Close switch.
9. Adjust carbon pile for 9 VDC indication on voltmeter.
10. Ammeter should indicate 6.5 to 7.0 amperes.

**NOTE**

If ammeter does not indicate 6.5 to 7.0 amperes, record test results and forward to Direct Support Maintenance with defective starter (solenoid switch defective).

11. Disconnect starter from test setup; connect field coil lead to solenoid M terminal and install starter (see *Installation/Replacement* in this work package).

**END OF TASK**

**INSTALLATION/REPLACEMENT**

1. Position starter (Figure 5, Item 12) and ground cable (Figure 5, Item 11) on engine.
2. Install three new lockwashers (Figure 5, Item 10) and capscrews (Figure 5, Item 9) on solenoid and tighten capscrews.
3. Install two cables (Figure 5, Items 6 and 7), wire (Figure 5, Item 8), new lockwasher (Figure 5, Item 5), and nut (Figure 5, Item 4) on terminal B of solenoid switch and tighten nut.
4. Install wire (Figure 5, Item 3), new lockwasher (Figure 5, Item 2), and nut (Figure 5, Item 1) on terminal S of solenoid switch and tighten nut.
5. Use silicone rubber sealant on terminals B, M, and S of solenoid switch.

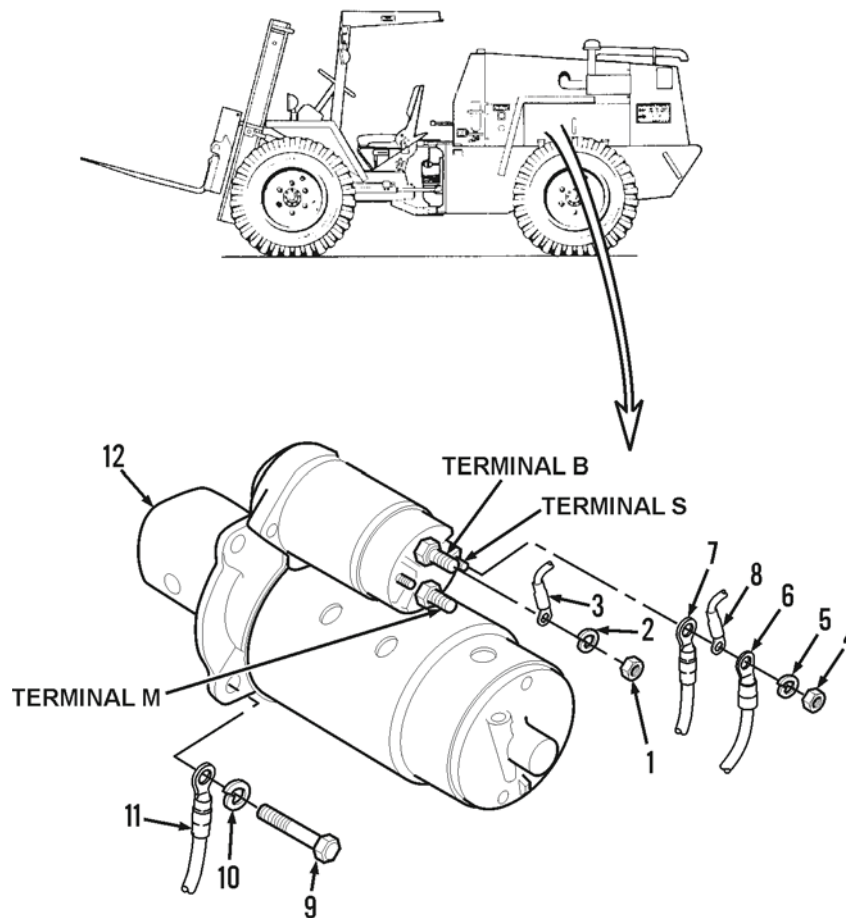

444-1056

**Figure 5. Starter.****END OF TASK****END OF WORK PACKAGE**



---

## ORGANIZATIONAL MAINTENANCE INSTRUCTIONS

### STARTER REPLACEMENT (MODEL 4-390)

Removal, Cleaning, Inspection, Installation/Replacement

---

#### INITIAL SETUP

##### Maintenance Level

Organizational

##### Tools and Special Tools

Tool kit, general mechanic's (Item 15, WP 0309)

Shop equipment, common no. 1 (Item 2, WP 0309)

##### Materials/Parts

Cleaning compound, solvent (Item 10, WP 0310)

Rag, wiping (Item 26, WP 0310)

Lockwasher (3)

##### Equipment Condition

Left side panel removed (WP 0179)

Battery ground cable disconnected (WP 0134)

---

**REMOVAL**

1. Remove nut (Figure 1, Item 1) and lockwasher (Figure 1, Item 2) from large terminal of starter solenoid. Discard lockwasher.
2. Remove cables (Figure 1, Items 3 and 4) and wires (Figure 1, Items 5 and 6) from large terminal of starter solenoid.
3. Remove screw (Figure 1, Item 7) and wire (Figure 1, Item 8) from small terminal of starter solenoid.
4. Support starter (Figure 1, Item 11) and remove two capscrews (Figure 1, Item 9) and lockwashers (Figure 1, Item 10) from starter. Discard lockwashers.
5. Remove starter (Figure 1, Item 11) from engine.

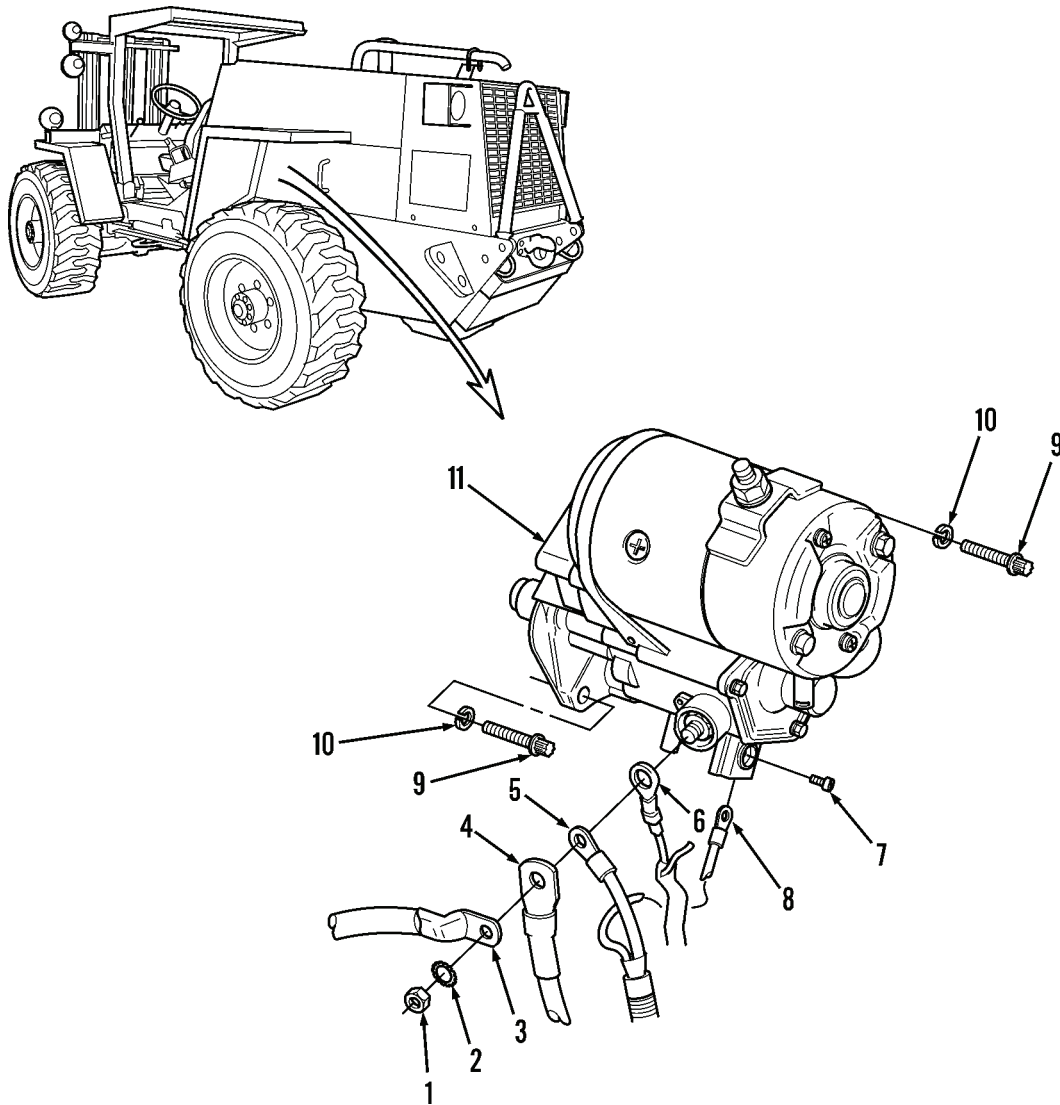
**Figure 1. Starter.**

444-0101

**END OF TASK**

**CLEANING**

1. Wipe exterior of starter (Figure 1, Item 11) with clean, dry rag.

**WARNING**

- Solvent cleaning compound MIL-PRF-680 Type III is an environmentally compliant and low toxic material. However, it may be irritating to the eyes and skin. Use protective gloves and goggles. Use in well-ventilated areas. Keep away from open flames and other sources of ignition. Failure to do so may result in injury or death to personnel.
  - Particles blown by compressed air are hazardous. **DO NOT** exceed 15 PSI (103 kPa) nozzle pressure when drying parts with compressed air. **DO NOT** direct compressed air against human skin. Make sure air stream is directed away from user and other personnel in the area. To prevent injury, user must wear protective goggles or face shield. Failure to follow this warning may result in injury to personnel.
2. Use solvent cleaning compound on connectors only.
  3. Clean cables (Figure 1, Items 3 and 4) and wires (Figure 1, Items 5, 6, and 8) with clean, dry rag.
  4. Use solvent cleaning compound to clean all hardware. Dry thoroughly with compressed air.

**END OF TASK****INSPECTION**

1. Inspect all hardware. Replace if worn or damaged.
2. Inspect cables (Figure 1, Items 3 and 4) and wires (Figure 1, Items 5, 6, and 8). Replace if insulation frayed or conductors broken.
3. Inspect starter (Figure 2, Item 11). Replace if pinion gear teeth chipped, damaged, or excessively worn.

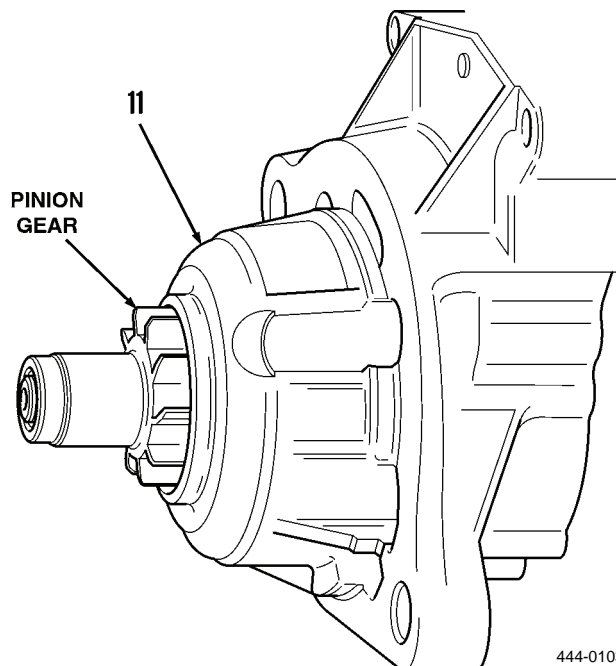

444-0103

**Figure 2. Starter Inspection.****END OF TASK**

**INSTALLATION/REPLACEMENT**

1. Position starter (Figure 3, Item 11) on engine.
2. Install two new lockwashers (Figure 3, Item 10) and capscrews (Figure 3, Item 9) on starter (Figure 3, Item 11).
3. Connect wire (Figure 3, Item 8) and screw (Figure 3, Item 7) to small terminal of starter solenoid.
4. Position wires (Figure 3, Items 6 and 5) and cables (Figure 3, Items 4 and 3) on large terminal of starter solenoid.
5. Install new lockwasher (Figure 3, Item 2) and nut (Figure 3, Item 1) on large terminal of starter solenoid.

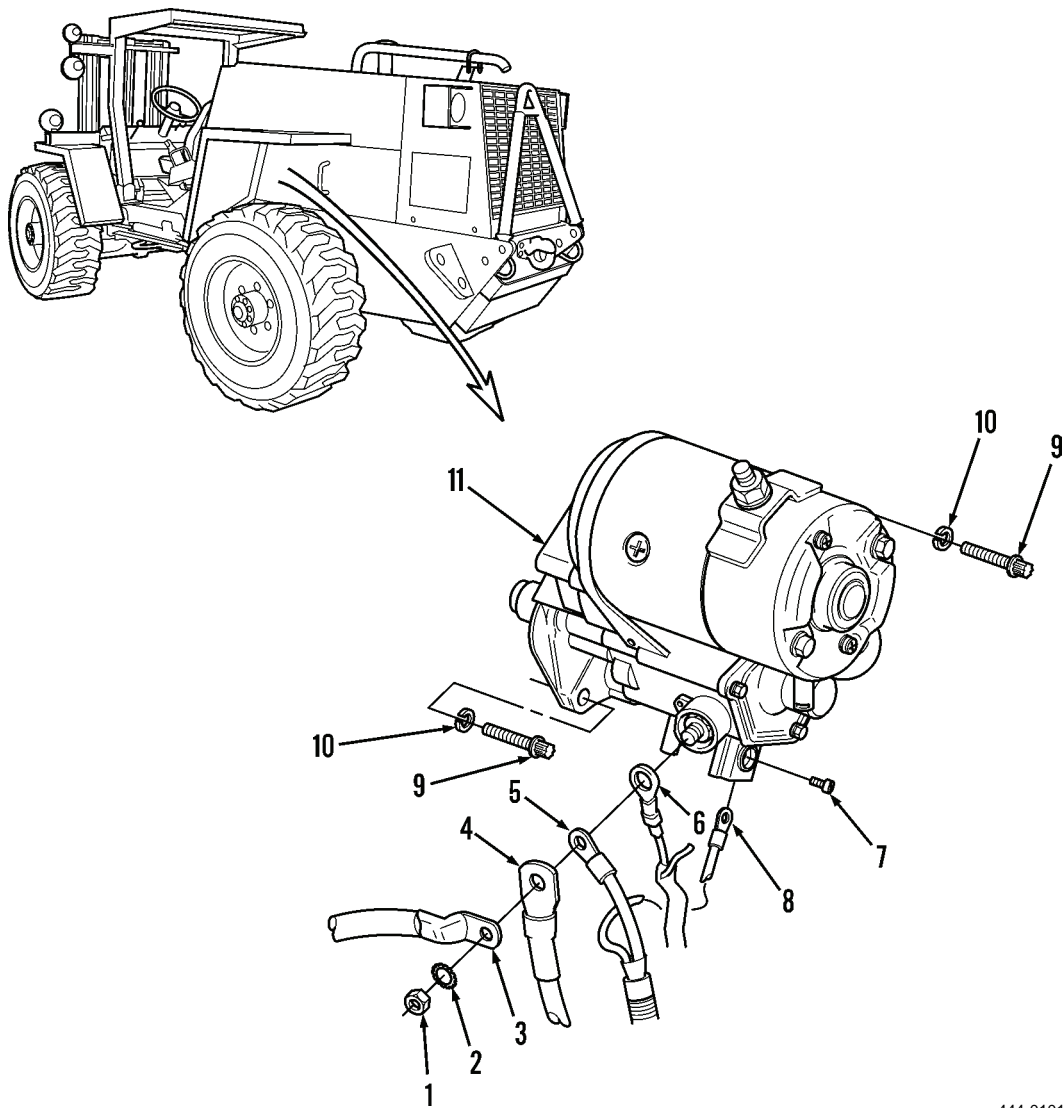

444-0101

**Figure 3. Starter.****END OF TASK****END OF WORK PACKAGE**

---

## ORGANIZATIONAL MAINTENANCE INSTRUCTIONS

### STARTER RELAY AND 25 AMP CIRCUIT BREAKER REPLACEMENT (MODEL 207)

#### Removal, Cleaning, Inspection, Installation

---

#### INITIAL SETUP

**Maintenance Level**

Organizational

**Tools and Special Tools**

Tool kit, general mechanic's (Item 15, WP 0309)

Shop equipment, common no. 1 (Item 2, WP 0309)

**Materials/Parts**

Cleaning compound, solvent (Item 10, WP 0310)

**Materials/Parts - Continued**

Rag, wiping (Item 26, WP 0310)

RTV sealant (Item 31, WP 0310)

Tag, marker (Item 33, WP 0310)

Lockwasher (9)

**Equipment Condition**

Engine OFF

Left side panel removed (WP 0179)

Battery ground cable disconnected (WP 0133)

---

## NOTE

Tag all electrical leads.

## REMOVAL

1. Remove nut (Figure 1, Item 1), lockwasher (Figure 1, Item 2), and wire from relay center terminals. Discard lockwasher.
2. Remove two nuts (Figure 1, Item 3), lockwashers (Figure 1, Item 4), and four wires from relay end terminals. Discard lockwashers.
3. Support relay (Figure 1, Item 8) and mounting plate (Figure 1, Item 15) and remove two capscrews (Figure 1, Item 5), lockwashers (Figure 1, Item 6), and washers (Figure 1, Item 7). Discard lockwashers.
4. Remove starter relay (Figure 1, Item 8) from mounting plate (Figure 1, Item 15).
5. Remove two nuts (Figure 1, Item 9), lockwashers (Figure 1, Item 10), and three wires from circuit breaker terminals. Discard lockwashers.
6. Support circuit breaker (Figure 1, Item 14) and mounting plate (Figure 1, Item 15) and remove two nuts (Figure 1, Item 11), lockwashers (Figure 1, Item 12), and screws (Figure 1, Item 13). Discard lockwashers.
7. Separate circuit breaker (Figure 1, Item 14) and mounting plate (Figure 1, Item 15).

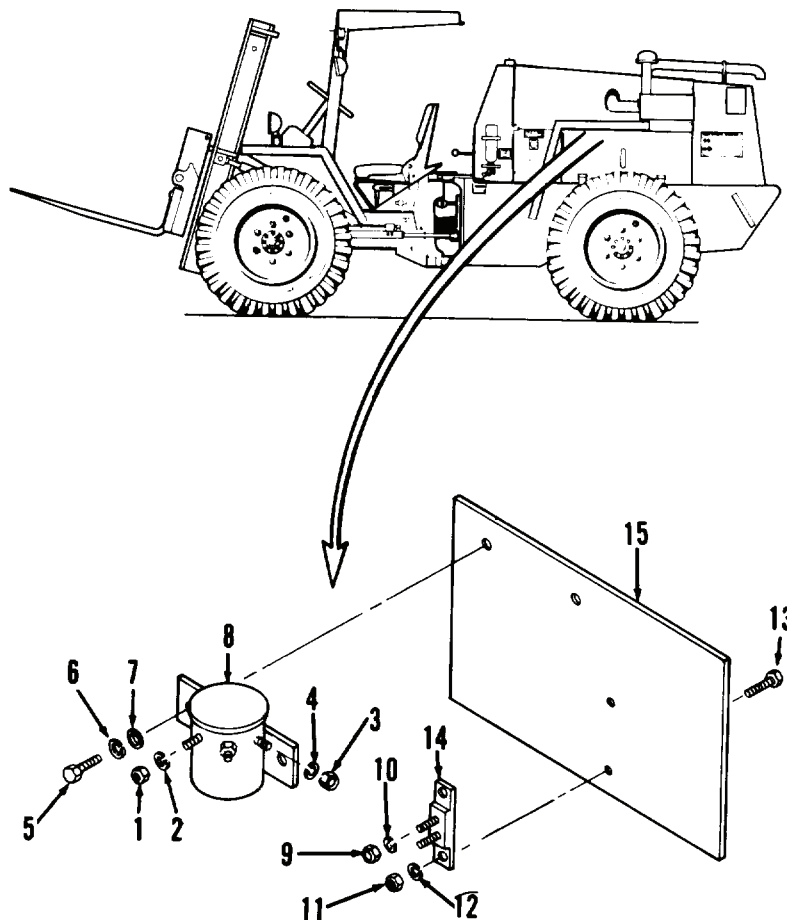

Figure 1. Starter Relay and 25 Amp Circuit.

END OF TASK

**CLEANING**

1. Wipe exterior of starter relay (Figure 1, Item 8) and circuit breaker (Figure 1, Item 14) with clean, dry cloth.

**WARNING**

- Solvent cleaning compound MIL-PRF-680 Type III is an environmentally compliant and low toxic material. However, it may be irritating to the eyes and skin. Use protective gloves and goggles. Use in well-ventilated areas. Keep away from open flames and other sources of ignition. Failure to do so may result in injury or death to personnel.
  - Particles blown by compressed air are hazardous. DO NOT exceed 15 PSI (103 kPa) nozzle pressure when drying parts with compressed air. DO NOT direct compressed air against human skin. Make sure air stream is directed away from user and other personnel in the area. To prevent injury, user must wear protective goggles or face shield. Failure to follow this warning may result in injury to personnel.
2. Use solvent cleaning compound on connectors and terminals only.
  3. Use solvent cleaning compound to clean all hardware and mounting plate. Dry thoroughly with compressed air.

**END OF TASK****INSPECTION**

1. Inspect all hardware. Replace if worn, or if threads damaged.
2. Inspect wire. Replace if insulation frayed, or if conductors broken.
3. Inspect mounting plate (Figure 1, Item 15). Replace if cracked or damaged.

**END OF TASK****INSTALLATION**

1. Position circuit breaker (Figure 1, Item 14) on mounting plate (Figure 1, Item 15).
2. Install two screws (Figure 1, Item 13), new lockwashers (Figure 1, Item 12), and nuts (Figure 1, Item 11) and tighten screws.
3. Position mounting plate (Figure 1, Item 15) and starter relay (Figure 1, Item 8) on engine.
4. Install two washers (Figure 1, Item 7), new lockwashers (Figure 1, Item 6), and capscrews (Figure 1, Item 5) and tighten capscrews.
5. Install three wires, two new lockwashers (Figure 1, Item 10), and nuts (Figure 1, Item 9) on circuit breaker terminals and tighten nuts.
6. Install four wires, two new lockwashers (Figure 1, Item 4), and nuts (Figure 1, Item 3) on relay end terminals and tighten nuts.
7. Install wire, new lockwasher (Figure 1, Item 2), and nut (Figure 1, Item 1) on relay center terminal and tighten nut.
8. Use silicone rubber sealer to seal relay and circuit breaker terminals.

**END OF TASK****END OF WORK PACKAGE**





---

## ORGANIZATIONAL MAINTENANCE INSTRUCTIONS

### RELAY PANEL COVER AND CAPACITOR REPLACEMENT (MODEL 4-390)

#### Removal, Cleaning, Inspection, Installation

---

#### INITIAL SETUP

**Maintenance Level**

Organizational

**Tools and Special Tools**

Tool kit, general mechanic's (Item 15, WP 0309)

Shop equipment, common no. 1 (Item 2, WP 0309)

**Materials/Parts**

Cleaning compound, solvent (Item 10, WP 0310)

Rag, wiping (Item 26, WP 0310)

Lockwasher (7)

**Equipment Condition**

Engine OFF

Left side panel removed (WP 0179)

Battery ground cable disconnected (WP 0134)

---

**REMOVAL**

1. Remove two nuts (Figure 1, Item 1), lockwashers (Figure 1, Item 2), washers (Figure 1, Item 3), cover (Figure 1, Item 4), and two spacer sleeves (Figure 1, Item 5) from control panel bracket (Figure 1, Item 6) and two long capscrews (Figure 1, Item 7). Discard lockwashers.
2. Remove two nuts (Figure 1, Item 8), lockwashers (Figure 1, Item 9), ground cable (Figure 1, Item 10), two washers (Figure 1, Item 11), capscrews (Figure 1, Item 12), and control panel bracket (Figure 1, Item 6) from vehicle frame. Discard lockwashers.
3. Remove two long capscrews (Figure 1, Item 7) from rear of control panel bracket (Figure 1, Item 6).

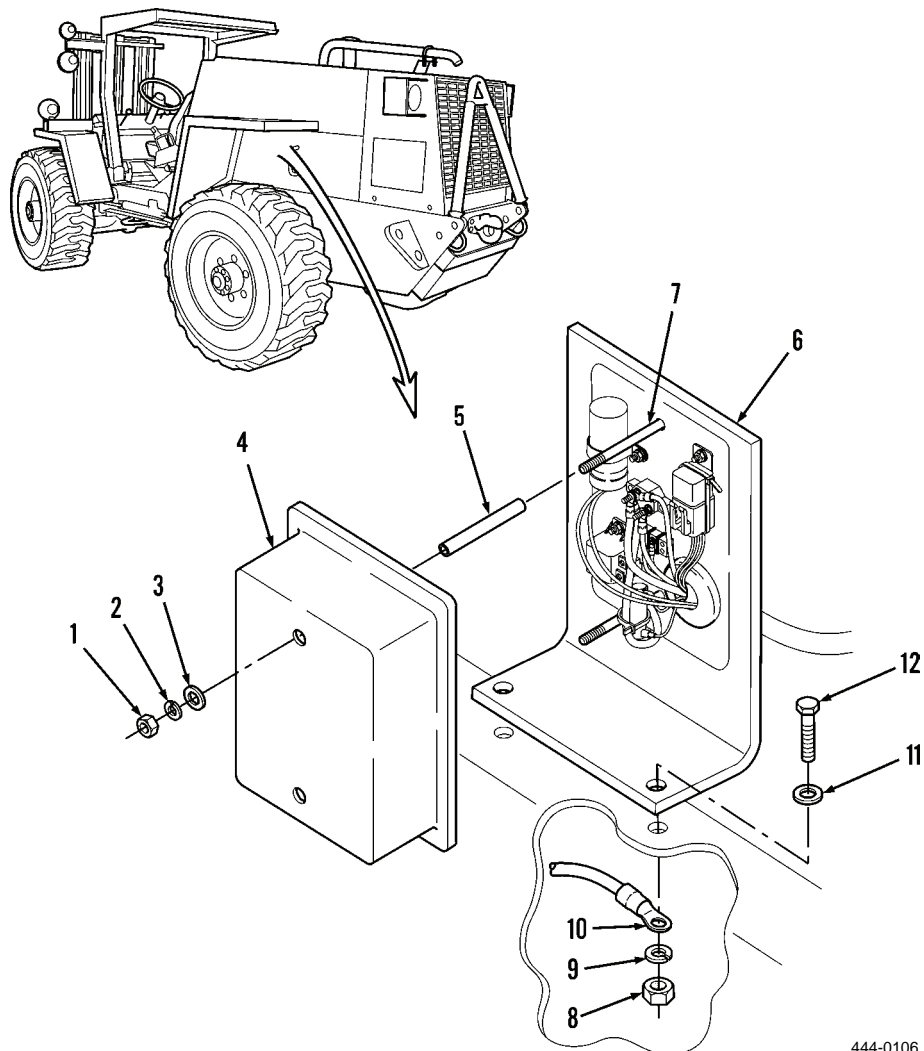

444-0106

**Figure 1. Relay Panel Cover and Capacitor.**

4. Remove nut (Figure 2, Item 13), lockwasher (Figure 2, Item 14), loop clamp (Figure 2, Item 15), and capscrew (Figure 2, Item 16) from control panel bracket (Figure 2, Item 6). Discard lockwasher.
5. Remove loop clamp (Figure 2, Item 15) from capacitor (Figure 2, Item 17).
6. Remove screw (Figure 2, Item 18), lockwasher (Figure 2, Item 19), black wire (Figure 2, Item 20) of fuel injector harness, and black wire 155 (Figure 2, Item 21) of relay harness from positive (+) terminal of capacitor (Figure 2, Item 17). Discard lockwasher.
7. Remove screw (Figure 2, Item 22), lockwasher (Figure 2, Item 23), and orange wire 957B (Figure 2, Item 24) of starter lock-out relay from unmarked terminal of capacitor (Figure 2, Item 17). Discard lockwasher.

REMOVAL - CONTINUED

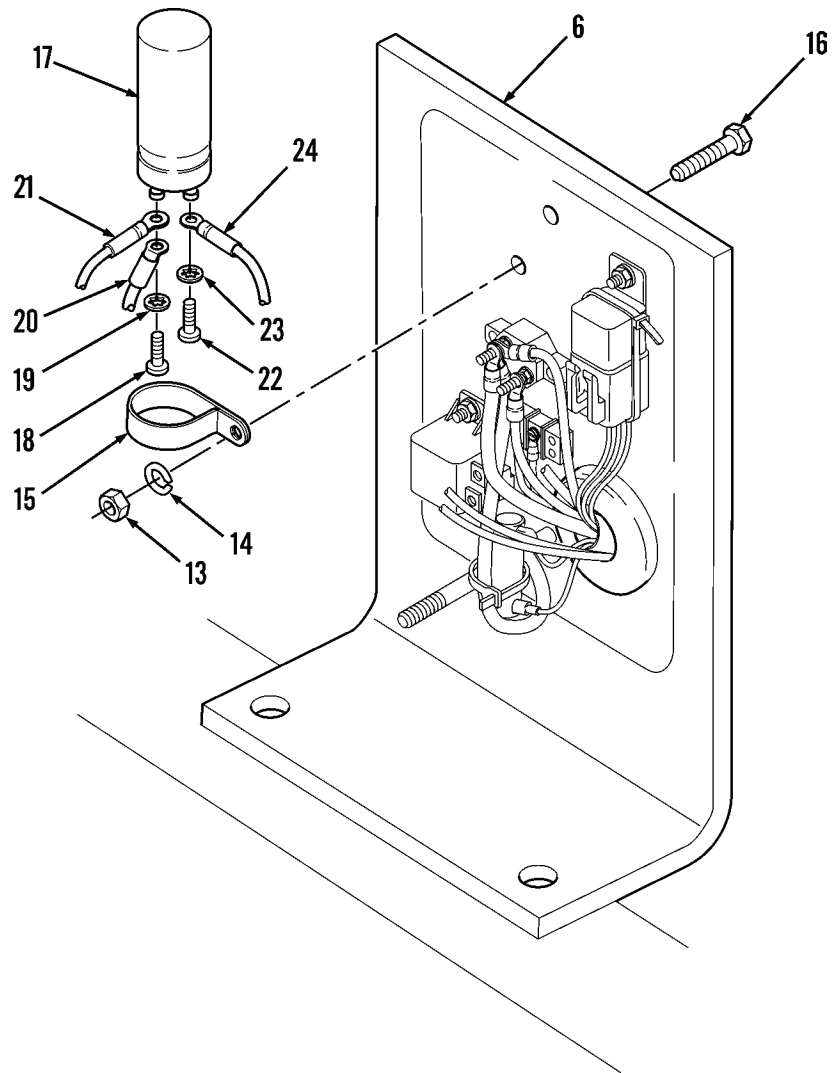

444-0108

Figure 2. Capacitor Assembly.

END OF TASK

**CLEANING**

1. Wipe exterior of cover (Figure 1, Item 4) and capacitor (Figure 2, Item 17) with clean, dry rag.

**WARNING**

- Solvent cleaning compound MIL-PRF-680 Type III is an environmentally compliant and low toxic material. However, it may be irritating to the eyes and skin. Use protective gloves and goggles. Use in well-ventilated areas. Keep away from open flames and other sources of ignition. Failure to do so may result in injury or death to personnel.
  - Particles blown by compressed air are hazardous. DO NOT exceed 15 PSI (103 kPa) nozzle pressure when drying parts with compressed air. DO NOT direct compressed air against human skin. Make sure air stream is directed away from user and other personnel in the area. To prevent injury, user must wear protective goggles or face shield. Failure to follow this warning may result in injury to personnel.
2. Clean wire connectors and terminals. Use solvent cleaning compound on connectors and terminals only.
  3. Use solvent cleaning compound to clean all hardware. Dry thoroughly with compressed air.

**END OF TASK****INSPECTION**

1. Inspect all hardware. Replace if worn, or if threads damaged.
2. Inspect wires. Replace if insulation frayed, or if conductors broken.

**END OF TASK****INSTALLATION**

1. Connect orange wire 957B (Figure 3, Item 24) of starter lock-out relay, new lockwasher (Figure 3, Item 23), and screw (Figure 3, Item 22) to unmarked terminal of capacitor (Figure 3, Item 17).
2. Install black wire 155 (Figure 3, Item 21) of relay harness, black wire (Figure 3, Item 20) of fuel injector harness, new lockwasher (Figure 3, Item 19), and screw (Figure 3, Item 18) on positive (+) terminal of capacitor (Figure 3, Item 17).
3. Position loop clamp (Figure 3, Item 15) around capacitor (Figure 3, Item 17).
4. Install capscrew (Figure 3, Item 16), loop clamp (Figure 3, Item 15), new lockwasher (Figure 3, Item 14), and nut (Figure 3, Item 13) on control panel bracket (Figure 1, Item 6).

INSTALLATION - CONTINUED

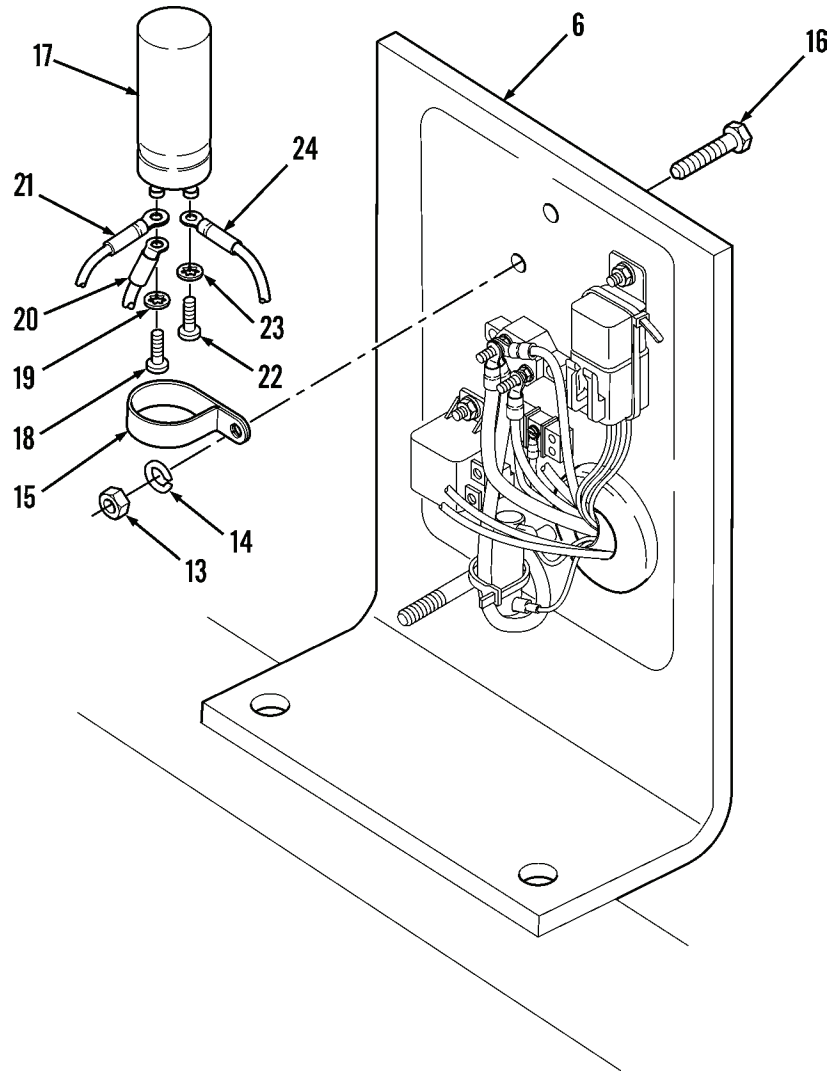

444-0108

Figure 3. Capacitor Assembly.

**INSTALLATION - CONTINUED**

5. Position two long capscrews (Figure 4, Item 7) through rear of control panel bracket (Figure 4, Item 6).
6. Install control panel bracket (Figure 4, Item 6), two capscrews (Figure 4, Item 12), washers (Figure 4, Item 11), ground cable (Figure 4, Item 10), two new lockwashers (Figure 4, Item 9), and nuts (Figure 4, Item 8) on vehicle frame.
7. Install two spacer sleeves (Figure 4, Item 5), cover (Figure 4, Item 4), washers (Figure 4, Item 3), new lockwashers (Figure 4, Item 2), and nuts (Figure 4, Item 1) on two long capscrews (Figure 4, Item 7) and control panel bracket (Figure 4, Item 6).

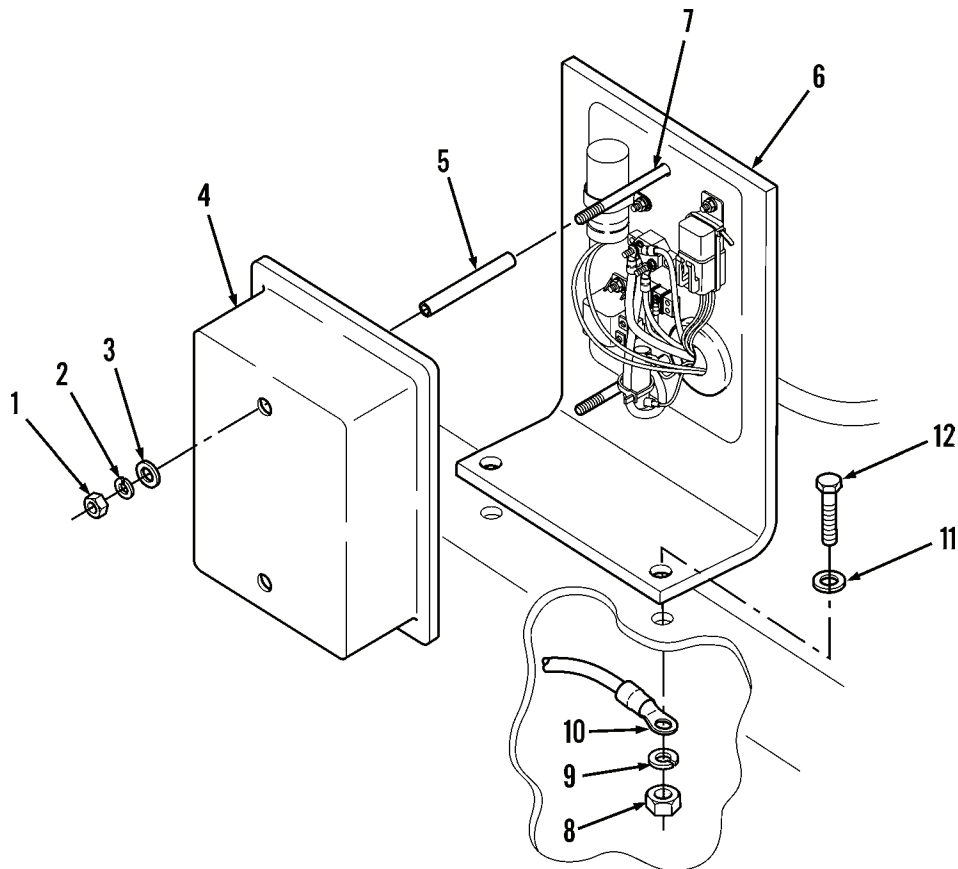

444-0107

**Figure 4. Relay Panel Cover and Capacitor.****END OF TASK****END OF WORK PACKAGE**

---

**ORGANIZATIONAL MAINTENANCE INSTRUCTIONS**  
**STARTER LOCK-OUT RELAY REPLACEMENT (MODEL 4-390)**  
**Removal, Installation**

---

**INITIAL SETUP****Maintenance Level**

Organizational

**Tools and Special Tools**

Tool kit, general mechanic's (Item 15, WP 0309)

Shop equipment, common no. 1 (Item 2, WP 0309)

**Materials/Parts**

Cleaning compound, solvent (Item 10, WP 0310)

**Materials/Parts - Continued**

Rag, wiping (Item 26, WP 0310)

Strap, tiedown (Item 32, WP 0310)

Lockwasher

**Equipment Condition**

Engine OFF

Left side panel removed (WP 0179)

Battery ground cable disconnected (WP 0134)

Relay panel cover removed (WP 0098)

**REMOVAL**

1. Cut tiedown strap (Figure 1, Item 1) from around starter lock-out relay (Figure 1, Item 2) and connector (Figure 1, Item 3) of relay harness. Discard tiedown strap.
2. Remove nut (Figure 1, Item 4), lockwasher (Figure 1, Item 5), starter lock-out relay (Figure 1, Item 2), and capscrew (Figure 1, Item 6) from control panel bracket (Figure 1, Item 7). Discard lockwasher.
3. Remove starter lock-out relay (Figure 1, Item 2) from connector (Figure 1, Item 3) of relay harness.

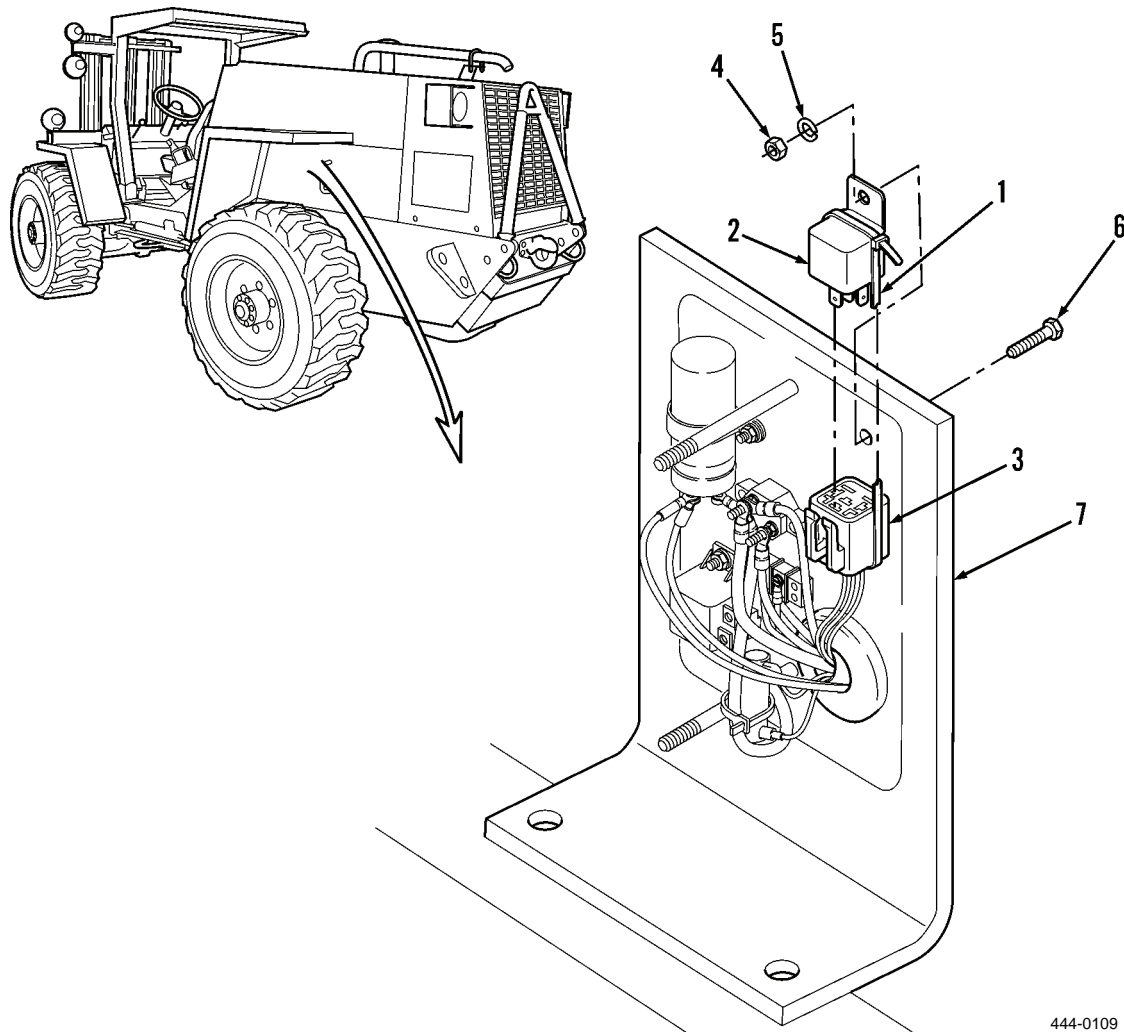

444-0109

**Figure 1. Starter Lock-Out Relay.****END OF TASK****INSTALLATION**

1. Install starter lock-out relay (Figure 1, Item 2) on connector (Figure 1, Item 3) of relay harness.
2. Install capscrew (Figure 1, Item 6), starter lock-out relay (Figure 1, Item 2), new lockwasher (Figure 1, Item 5), and nut (Figure 1, Item 4) on control panel bracket (Figure 1, Item 7).
3. Install new tiedown strap (Figure 1, Item 1) around connector (Figure 1, Item 3) of relay harness and starter lock-out relay (Figure 1, Item 2).

**END OF TASK****END OF WORK PACKAGE**



---

## ORGANIZATIONAL MAINTENANCE INSTRUCTIONS

### 25 AMP BREAKER REPLACEMENT (MODEL 4-390)

#### Removal, Installation

---

#### INITIAL SETUP

**Maintenance Level**

Organizational

**Tools and Special Tools**

Tool kit, general mechanic's (Item 15, WP 0309)

Shop equipment, common no. 1 (Item 2, WP 0309)

**Materials/Parts**

Rag, wiping (Item 26, WP 0310)

Lockwasher (4)

**Equipment Condition**

Engine OFF

Left side panel removed (WP 0179)

Battery ground cable disconnected (WP 0134)

Relay panel cover removed (WP 0098)

Control panel bracket separated from vehicle frame  
(WP 0098)

**REMOVAL**

1. Remove nut (Figure 1, Item 1), lockwasher (Figure 1, Item 2), large red cable (Figure 1, Item 3), jumper cable (Figure 1, Item 4), and red wire #2 (Figure 1, Item 5) from upper-left terminal of 25 amp breaker (Figure 1, Item 6). Discard lockwasher.
2. Remove nut (Figure 1, Item 7), lockwasher (Figure 1, Item 8), and wires 934A/934B (Figure 1, Item 9) from lower-right terminal of 25 amp breaker (Figure 1, Item 6). Discard lockwasher.
3. Remove two nuts (Figure 1, Item 10), lockwashers (Figure 1, Item 11), and screws (Figure 1, Item 12) from control panel bracket (Figure 1, Item 13) and 25 amp breaker (Figure 1, Item 6). Discard lockwasher.
4. Remove 25 amp breaker (Figure 1, Item 6) from control panel bracket (Figure 1, Item 13).

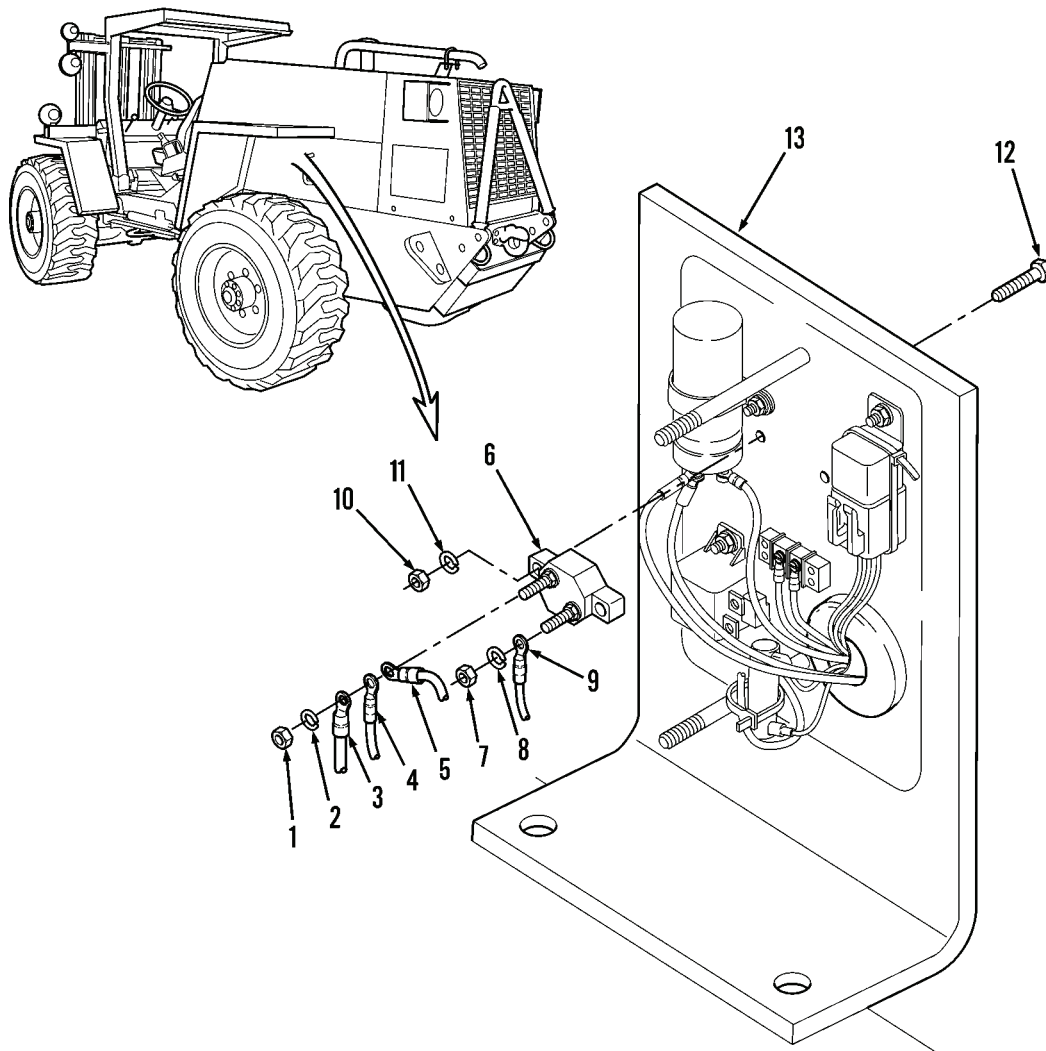

**Figure 1. 25 Amp Breaker.**

444-0111

**END OF TASK**

**INSTALLATION**

1. Position 25 amp breaker (Figure 1, Item 6) on control panel bracket (Figure 1, Item 13).
2. Install two screws (Figure 1, Item 12), new lockwashers (Figure 1, Item 11), and nuts (Figure 1, Item 10) on 25 amp breaker (Figure 1, Item 6) and control panel bracket (Figure 1, Item 13).
3. Install wires 934A/934B (Figure 1, Item 9), new lockwasher (Figure 1, Item 8), and nut (Figure 1, Item 7) on lower-right terminal of 25 amp breaker (Figure 1, Item 6).
4. Install red wire #2 (Figure 1, Item 5), jumper cable (Figure 1, Item 4), large red cable (Figure 1, Item 3), new lockwasher (Figure 1, Item 2), and nut (Figure 1, Item 1) on upper-left terminal of 25 amp breaker (Figure 1, Item 6).

**END OF TASK****END OF WORK PACKAGE**



---

## ORGANIZATIONAL MAINTENANCE INSTRUCTIONS

### TERMINAL BLOCK REPLACEMENT (MODEL 4-390)

#### Removal, Installation

---

#### INITIAL SETUP

**Maintenance Level**

Organizational

**Tools and Special Tools**

Tool kit, general mechanic's (Item 15, WP 0309)

Shop equipment, common no. 1 (Item 2, WP 0309)

**Materials/Parts**

Rag, wiping (Item 26, WP 0310)

**Materials/Parts - Continued**

Lockwasher (2)

**Equipment Condition**

Engine OFF

Left side panel removed (WP 0179)

Battery ground cable disconnected (WP 0134)

Relay panel cover removed (WP 0098)

Control panel bracket separated from vehicle frame  
(WP 0098)

---

**REMOVAL**

1. Remove two nuts (Figure 1, Item 1), lockwashers (Figure 1, Item 2), screws (Figure 1, Item 3), and terminal block (Figure 1, Item 4) from control panel bracket (Figure 1, Item 5). Discard lockwashers.
2. Remove screw (Figure 1, Item 6) and orange wire #957C (Figure 1, Item 7) from left terminal of terminal block (Figure 1, Item 4).
3. Remove screw (Figure 1, Item 8) and orange wire #957A (Figure 1, Item 9) from right terminal of terminal block (Figure 1, Item 4).
4. Remove two screws (Figure 1, Item 10) from terminal block (Figure 1, Item 4).
5. Remove 100 Ohm resistor (Figure 1, Item 11) from terminal block (Figure 1, Item 4).

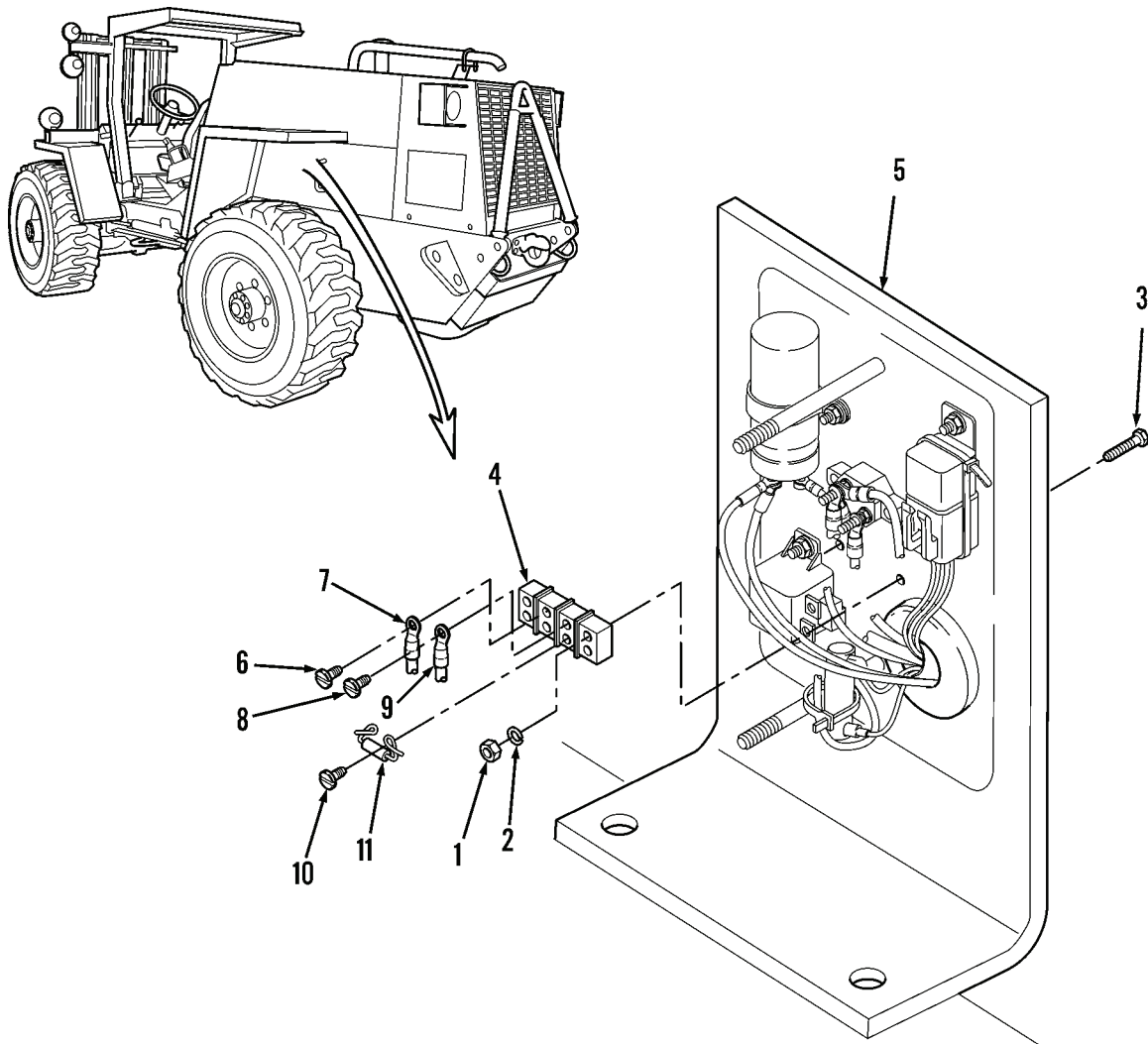

444-0113

**Figure 1. Terminal Block.****END OF TASK**

**INSTALLATION**

1. Position 100 Ohm resistor (Figure 1, Item 11) on terminal block (Figure 1, Item 4) and install two screws (Figure 1, Item 10).
2. Connect orange wire #957A (Figure 1, Item 9) and screw (Figure 1, Item 8) to right terminal of terminal block (Figure 1, Item 4).
3. Connect orange wire #957C (Figure 1, Item 7) and screw (Figure 1, Item 6) to left terminal of terminal block (Figure 1, Item 4).
4. Position terminal block (Figure 1, Item 4) and install two screws (Figure 1, Item 3), new lockwashers (Figure 1, Item 2), and nut (Figure 1, Item 1) on control panel bracket (Figure 1, Item 5).

**END OF TASK****END OF WORK PACKAGE**





---

## ORGANIZATIONAL MAINTENANCE INSTRUCTIONS

### STARTER RELAY REPLACEMENT (MODEL 4-390)

#### Removal, Installation

---

#### INITIAL SETUP

**Maintenance Level**

Organizational

**Tools and Special Tools**

Tool kit, general mechanic's (Item 15, WP 0309)

Shop equipment, common no. 1 (Item 2, WP 0309)

**Materials/Parts**

Rag, wiping (Item 26, WP 0310)

**Materials/Parts - Continued**

Lockwasher (2)

**Equipment Condition**

Engine OFF

Left side panel removed (WP 0179)

Battery ground cable disconnected (WP 0134)

Relay panel cover removed (WP 0098)

Control panel bracket separated from vehicle frame  
(WP 0098)

---

**REMOVAL**

1. Remove two nuts (Figure 1, Item 1), lockwashers (Figure 1, Item 2), capscrews (Figure 1, Item 3), and starter relay (Figure 1, Item 4) from control panel bracket (Figure 1, Item 5). Discard lockwashers.
2. Remove screw (Figure 1, Item 6), clip (Figure 1, Item 7), orange wire (Figure 1, Item 8) of cable harness, and white wire #932 (Figure 1, Item 9) of relay harness from upper terminal of starter relay (Figure 1, Item 4).
3. Remove screw (Figure 1, Item 10), clip (Figure 1, Item 11), and red jumper wire (Figure 1, Item 12) from lower terminal of starter relay (Figure 1, Item 4).
4. Remove two-wire connector (Figure 1, Item 13) of relay harness with purple wire #6 and black wire #154 from lower rear terminals of starter relay (Figure 1, Item 4).

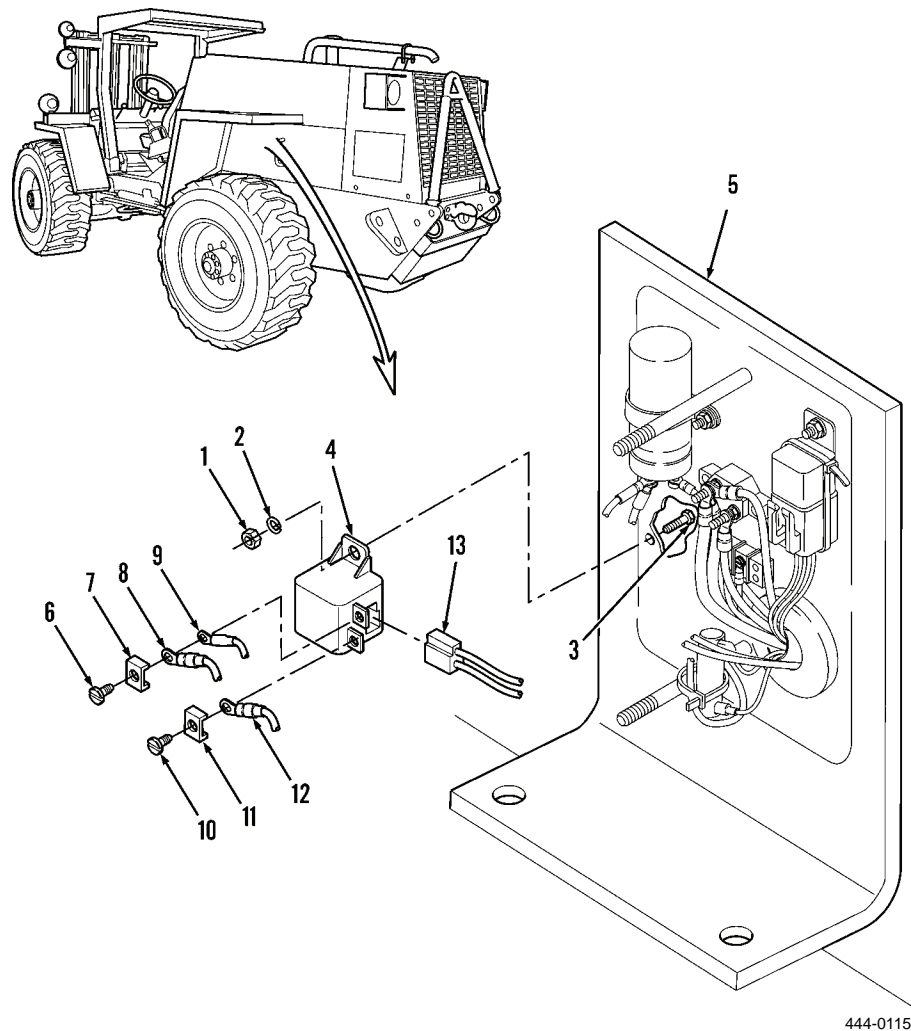

444-0115

**Figure 1. Starter Relay Assembly.****END OF TASK**

---

**INSTALLATION**

1. Connect two-wire connector (Figure 1, Item 13) of relay harness with purple wire #6 and black wire #154 to lower rear terminals of starter relay (Figure 1, Item 4).
2. Connect red jumper wire (Figure 1, Item 12), clip (Figure 1, Item 11), and screw (Figure 1, Item 10) to lower terminal of starter relay (Figure 1, Item 4).
3. Install white wire #932 (Figure 1, Item 9) of relay harness, orange wire (Figure 1, Item 8) of cable harness, clip (Figure 1, Item 7), and screw (Figure 1, Item 6) on upper terminal of starter relay (Figure 1, Item 4).
4. Install starter relay (Figure 1, Item 4), two capscrews (Figure 1, Item 3), new lockwashers (Figure 1, Item 2), and nuts (Figure 1, Item 1) on control panel bracket (Figure 1, Item 5).

**END OF TASK****END OF WORK PACKAGE**



---

## ORGANIZATIONAL MAINTENANCE INSTRUCTIONS

### RESISTOR REPLACEMENT (MODEL 4-390)

#### Removal, Installation

---

#### INITIAL SETUP

**Maintenance Level**

Organizational

**Tools and Special Tools**

Tool kit, general mechanic's (Item 15, WP 0309)

Shop equipment, common no. 1 (Item 2, WP 0309)

**Materials/Parts**

Rag, wiping (Item 26, WP 0310)

**Materials/Parts - Continued**

Strap, tiedown (Item 32, WP 0310)

Tape, electrical (Item 35, WP 0310)

Solder

**Equipment Condition**

Engine OFF

Left side panel removed (WP 0179)

Battery ground cable disconnected (WP 0134)

Relay panel cover removed (WP 0098)

---

**REMOVAL**

1. Cut tiedown strap (Figure 1, Item 1) from around resistor (Figure 1, Item 2), wire of cable harness, and jumper wire. Discard tiedown strap.
2. Cut and remove heat shrink insulation from two wires and terminals of resistor (Figure 1, Item 2).
3. Remove solder and disconnect black wire #940A (Figure 1, Item 3) and black wire #940B (Figure 1, Item 4) from terminals of resistor (2).

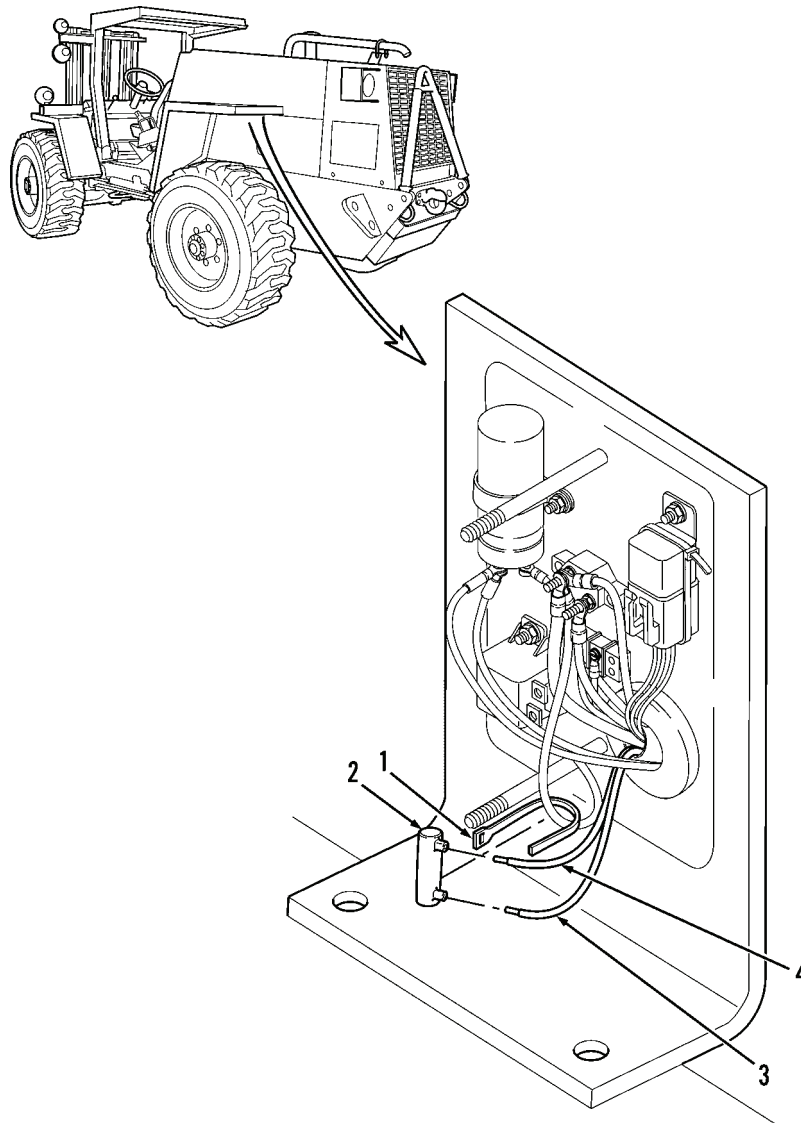
**Figure 1. Resistor Assembly.**

444-0117

**END OF TASK**

**INSTALLATION**

1. Solder black wire #940B (Figure 1, Item 4) and black wire #940A (Figure 1, Item 3) to terminals of resistor (Figure 1, Item 2).
2. Install electrical tape on terminals of resistor (Figure 1, Item 2).
3. Install new tiedown strap (Figure 1, Item 1) around resistor (Figure 1, Item 2), wire of cable harness, and jumper wire.

**END OF TASK****END OF WORK PACKAGE**





---

# ORGANIZATIONAL MAINTENANCE INSTRUCTIONS

## FLOODLIGHT SWITCHES AND CIRCUIT BREAKERS REPLACEMENT

### Removal, Cleaning, Inspection, Installation

---

#### INITIAL SETUP

**Maintenance Level**

Organizational

**Tools and Special Tools**

Tool kit, general mechanic's (Item 15, WP 0309)

Shop equipment, common no. 1 (Item 2, WP 0309)

**Materials/Parts**

Cleaning compound, solvent (Item 10, WP 0310)

**Materials/Parts - Continued**

Rag, wiping (Item 26, WP 0310)

RTV sealant (Item 31, WP 0310)

Strap, tiedown (Item 32, WP 0310)

Tag, marker (Item 33, WP 0310)

**Equipment Condition**

Engine OFF

Ignition switch in OFF position and key removed

Noise baffle mat removed (WP 0187)

---

#### NOTE

- 6 ampere circuit breaker connects to rear flood switch.
- 10 ampere circuit breaker connects to front flood switch.
- Tag all electrical leads.

**REMOVAL**

1. Remove two screws (Figure 1, Item 1) and wire leads from switch (Figure 1, Item 4).
2. Unplug and remove circuit breaker (Figure 1, Item 2) from harness lead.
3. Support switch (Figure 1, Item 4) and unscrew and remove rubber boot (Figure 1, Item 3).
4. Lower and remove switch (Figure 1, Item 4) and washer (Figure 1, Item 5) from instrument panel.
5. Cut and remove tiedown strap (Figure 1, Item 6) from harness wire. Discard tiedown strap.

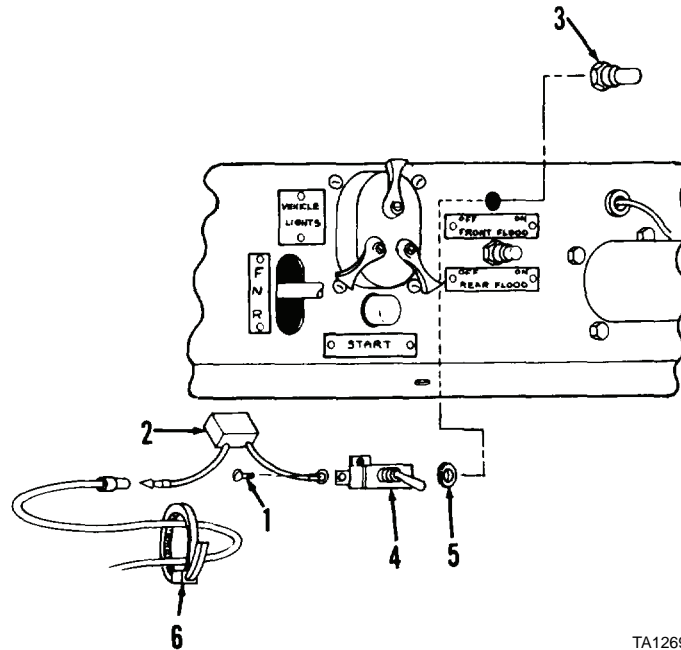

TA126925

**Figure 1. Floodlight Switches and Circuit Breakers.**

**END OF TASK****CLEANING**

1. Wipe switch (Figure 1, Item 4), rubber boot (Figure 1, Item 3), and circuit breaker (Figure 1, Item 2) with clean, dry rag.

**WARNING**

- Solvent cleaning compound MIL-PRF-680 Type III is an environmentally compliant and low toxic material. However, it may be irritating to the eyes and skin. Use protective gloves and goggles. Use in well-ventilated areas. Keep away from open flames and other sources of ignition. Failure to do so may result in injury or death to personnel.
  - Particles blown by compressed air are hazardous. **DO NOT** exceed 15 PSI (103 kPa) nozzle pressure when drying parts with compressed air. **DO NOT** direct compressed air against human skin. Make sure air stream is directed away from user and other personnel in the area. To prevent injury, user must wear protective goggles or face shield. Failure to follow this warning may result in injury to personnel.
2. Clean switch terminals and wire connectors. Use solvent cleaning compound on terminals and connectors only.

**CLEANING - CONTINUED**

3. Clean screws (Figure 1, Item 1). Use solvent cleaning compound. Dry thoroughly with compressed air.

**END OF TASK****INSPECTION**

1. Inspect rubber boot (Figure 1, Item 3). Replace if threads damaged, or if boot cracked or deteriorated.
2. Inspect harness and circuit breaker wires. Replace if insulation frayed, or if conductors broken.
3. Inspect switch (Figure 1, Item 4). Replace if threads or terminals damaged.

**END OF TASK****INSTALLATION**

1. Install circuit breaker lead, wire leads, and two screws (Figure 1, Item 1). Tighten screws.
2. Position switch (Figure 1, Item 4) and washer (Figure 1, Item 5) in instrument panel.
3. Install rubber boot (Figure 1, Item 3) and tighten rubber boot until switch (Figure 1, Item 4) is securely mounted.
4. Push in circuit breaker lead.
5. Install new tiedown strap (Figure 1, Item 6) around harness wire (to prevent circuit breaker from hanging).
6. Use silicone rubber sealer to seal wire leads and switch terminals.

**END OF TASK****END OF WORK PACKAGE**



---

## ORGANIZATIONAL MAINTENANCE INSTRUCTIONS

### START SWITCH AND VEHICLE LIGHTS SWITCH REPLACEMENT

Removal, Cleaning, Inspection, Installation

---

#### INITIAL SETUP

##### Maintenance Level

Organizational

##### Tools and Special Tools

Tool kit, general mechanic's (Item 15, WP 0309)

Shop equipment, common no. 1 (Item 2, WP 0309)

##### Materials/Parts

Cleaning compound, solvent (Item 10, WP 0310)

Rag, wiping (Item 26, WP 0310)

##### Materials/Parts - Continued

RTV sealant (Item 31, WP 0310)

Strap, tiedown (Item 32, WP 0310)

Tag, marker (Item 33, WP 0310)

Lockwasher (7)

##### Equipment Condition

Engine OFF

Ignition switch in OFF position and key removed

Noise baffle mat removed (WP 0187)

---

## NOTE

Tag all electrical leads.

## REMOVAL

1. Disconnect wire leads (Figure 1, Item 1) from start switch (Figure 1, Item 3).
2. Support start switch (Figure 1, Item 3) and remove rubber boot (Figure 1, Item 2).
3. Remove start switch (Figure 1, Item 3) from instrument panel.
4. Remove nut (Figure 1, Item 4), two screws (Figure 1, Item 5), washers (Figure 1, Item 6), and terminals (Figure 1, Item 7) from start switch (Figure 1, Item 3).
5. Disconnect harness connector (Figure 1, Item 8) from vehicle lights switch (Figure 1, Item 14).
6. Remove three screws (Figure 1, Item 9), lockwashers (Figure 1, Item 10), and lever (Figure 1, Item 11) from vehicle lights switch (Figure 1, Item 14). Discard lockwashers.
7. Support vehicle lights switch (Figure 1, Item 14) and remove four screws (Figure 1, Item 12) and lockwashers (Figure 1, Item 13). Discard lockwashers.
8. Remove vehicle lights switch (Figure 1, Item 14) from instrument panel.

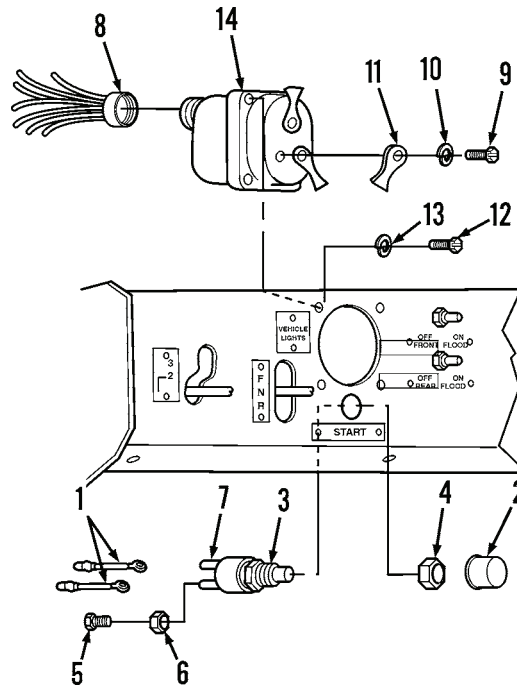

444-1061

Figure 1. Start Switch and Vehicle Lights Switch.

END OF TASK

**CLEANING**

1. Wipe switches (Figure 1, Items 3 and 14), rubber boot (Figure 1, Item 2), and harness connector (Figure 1, Item 8) with clean, dry rag.

**WARNING**

- Solvent cleaning compound MIL-PRF-680 Type III is an environmentally compliant and low toxic material. However, it may be irritating to the eyes and skin. Use protective gloves and goggles. Use in well-ventilated areas. Keep away from open flames and other sources of ignition. Failure to do so may result in injury or death to personnel.
  - Particles blown by compressed air are hazardous. **DO NOT** exceed 15 PSI (103 kPa) nozzle pressure when drying parts with compressed air. **DO NOT** direct compressed air against human skin. Make sure air stream is directed away from user and other personnel in the area. To prevent injury, user must wear protective goggles or face shield. Failure to follow this warning may result in injury to personnel.
2. Clean switch terminals and wire connectors. Use solvent cleaning compound on terminals and connectors only.
  3. Use solvent cleaning compound to clean all hardware. Dry thoroughly with compressed air.

**END OF TASK****INSPECTION**

1. Inspect rubber boot (Figure 1, Item 2). Replace if threads damaged, or if boot cracked or deteriorated.
2. Inspect harness and start switch wires. Replace if insulation frayed, or if conductors broken.
3. Inspect switches (Figure 1, Items 3 and 14). Replace if threads or terminals damaged.
4. Inspect terminal blades (Figure 1, Item 7). Replace if broken or corroded.
5. Inspect all hardware. Replace if worn, or if threads damaged.

**END OF TASK**

**INSTALLATION**

1. Position vehicle lights switch (Figure 2, Item 14) in instrument panel.
2. Install four screws (Figure 2, Item 12) and new lockwashers (Figure 2, Item 13) and tighten screws until vehicle lights switch (Figure 2, Item 14) is securely mounted.
3. Position three levers (Figure 2, Item 11) on shafts of vehicle lights switch (Figure 2, Item 14).
4. Install three screws (Figure 2, Item 9) and new lockwashers (Figure 2, Item 10) and tighten screws until levers (Figure 2, Item 11) are securely mounted.
5. Install harness connector (Figure 2, Item 8) on vehicle lights switch (Figure 2, Item 14) and tighten.
6. Install hex nut (Figure 2, Item 4) and position for 1/8 in. of start switch threads above instrument panel.
7. Install two screws (Figure 2, Item 5), washers (Figure 2, Item 6), and terminals (Figure 2, Item 7) on start switch (Figure 2, Item 3) and tighten screws.
8. Position start switch (Figure 2, Item 3) in instrument panel.
9. Install rubber boot (Figure 2, Item 2) and tighten rubber boot until start switch (Figure 2, Item 3) is securely mounted.
10. Connect wire leads (Figure 2, Item 1) to terminals (Figure 2, Item 7).
11. Use silicone rubber sealer to seal wire leads (Figure 2, Item 1), terminals (Figure 2, Item 7), and harness connector (Figure 2, Item 8).

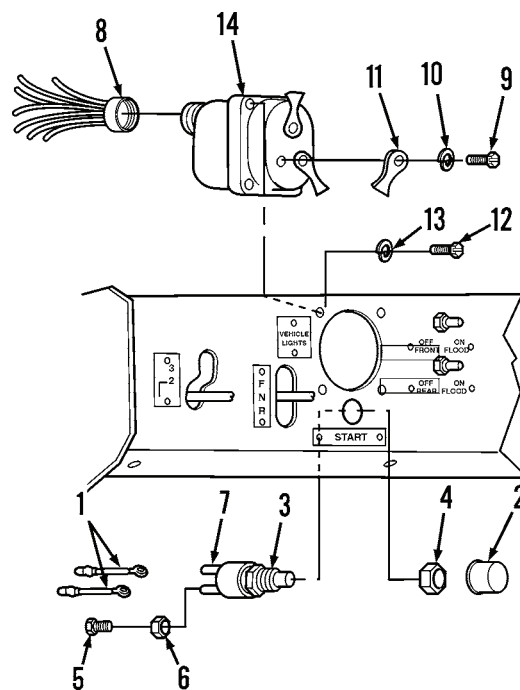

444-1061

**Figure 2. Start Switch and Vehicle Lights Switch.****END OF TASK****END OF WORK PACKAGE**



---

## ORGANIZATIONAL MAINTENANCE INSTRUCTIONS

### IGNITION SWITCH AND CIRCUIT BREAKER REPLACEMENT

Removal, Cleaning, Inspection, Installation

---

#### INITIAL SETUP

##### Maintenance Level

Organizational

##### Tools and Special Tools

Tool kit, general mechanic's (Item 15, WP 0309)

Shop equipment, common no. 1 (Item 2, WP 0309)

##### Materials/Parts

Cleaning compound, solvent (Item 10, WP 0310)

##### Materials/Parts - Continued

Rag, wiping (Item 26, WP 0310)

RTV sealant (Item 31, WP 0310)

Strap, tiedown (Item 32, WP 0310)

Tag, marker (Item 33, WP 0310)

##### Equipment Condition

Engine OFF

Ignition switch in OFF position and key removed

Noise baffle mat removed (WP 0187)

---

## NOTE

Tag all electrical leads.

## REMOVAL

1. Disconnect and remove circuit breaker (Figure 1, Item 1) from wire leads (Figure 1, Item 2).
2. Disconnect harness connector (Figure 1, Item 3) from ignition switch (Figure 1, Item 5).
3. Support ignition switch (Figure 1, Item 5) and remove hex nut (Figure 1, Item 4).
4. Remove ignition switch (Figure 1, Item 5) from instrument panel.
5. Cut and remove tiedown strap (Figure 1, Item 6) from harness wire. Discard tiedown strap.

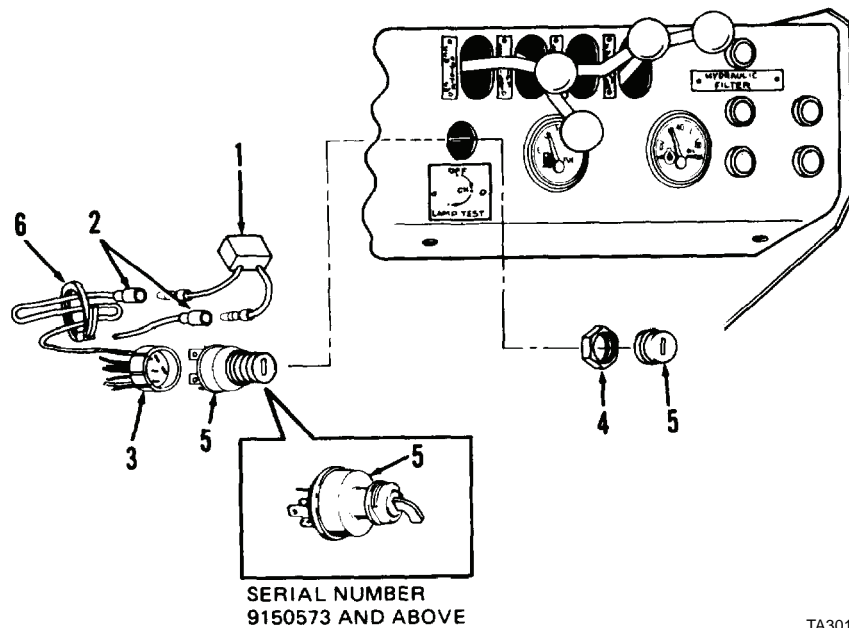

TA301521

Figure 1. Ignition Switch and Circuit Breaker.

END OF TASK

**CLEANING**

1. Wipe ignition switch (Figure 1, Item 5) with clean, dry rag.

**WARNING**

- Solvent cleaning compound MIL-PRF-680 Type III is an environmentally compliant and low toxic material. However, it may be irritating to the eyes and skin. Use protective gloves and goggles. Use in well-ventilated areas. Keep away from open flames and other sources of ignition. Failure to do so may result in injury or death to personnel.
  - Particles blown by compressed air are hazardous. **DO NOT** exceed 15 PSI (103 kPa) nozzle pressure when drying parts with compressed air. **DO NOT** direct compressed air against human skin. Make sure air stream is directed away from user and other personnel in the area. To prevent injury, user must wear protective goggles or face shield. Failure to follow this warning may result in injury to personnel.
2. Clean switch terminals and wire connectors. Use solvent cleaning compound on terminals and connectors only.
  3. Use solvent cleaning compound to clean hex nut (Figure 1, Item 4). Dry thoroughly with compressed air.

**END OF TASK****INSPECTION**

1. Inspect hex nut (Figure 1, Item 4). Replace if threads damaged.
2. Inspect harness and circuit breaker wires. Replace if insulation frayed, or if conductors broken.
3. Inspect ignition switch (Figure 1, Item 5). Replace if threads or terminals damaged.

**END OF TASK****INSTALLATION**

1. Position ignition switch (Figure 1, Item 5) in instrument panel.
2. Install hex nut (Figure 1, Item 4) and tighten nut until ignition switch (Figure 1, Item 5) is securely mounted.
3. Connect ignition switch terminals to harness connector (Figure 1, Item 3).
4. Connect circuit breaker (Figure 1, Item 1) leads to wire leads (Figure 1, Item 2).
5. Install new tiedown strap (Figure 1, Item 6) around wire (to prevent circuit breaker from hanging).

**END OF TASK****END OF WORK PACKAGE**



---

## ORGANIZATIONAL MAINTENANCE INSTRUCTIONS

### LOCK-OUT RELAY REPLACEMENT

#### Removal, Cleaning, Inspection, Installation

---

#### INITIAL SETUP

**Maintenance Level**

Organizational

**Tools and Special Tools**

Tool kit, general mechanic's (Item 15, WP 0309)

Shop equipment, common no. 1 (Item 2, WP 0309)

**Materials/Parts**

Cleaning compound, solvent (Item 10, WP 0310)

Rag, wiping (Item 26, WP 0310)

**Materials/Parts - Continued**

RTV sealant (Item 31, WP 0310)

Strap, tiedown (Item 32, WP 0310)

Tag, marker (Item 33, WP 0310)

Lockwasher (2)

**Equipment Condition**

Engine OFF

Ignition switch in OFF position and key removed

Noise baffle mat removed (WP 0187)

---

**NOTE**

Tag all electrical leads.

**REMOVAL**

1. Disconnect wire leads (Figure 1, Item 1) from relay terminals.
2. Support lock-out relay (Figure 1, Item 5) and remove two nuts (Figure 1, Item 2), lockwashers (Figure 1, Item 3), and capscrews (Figure 1, Item 4). Discard lockwashers.
3. Remove lock-out relay (Figure 1, Item 5) from instrument panel.

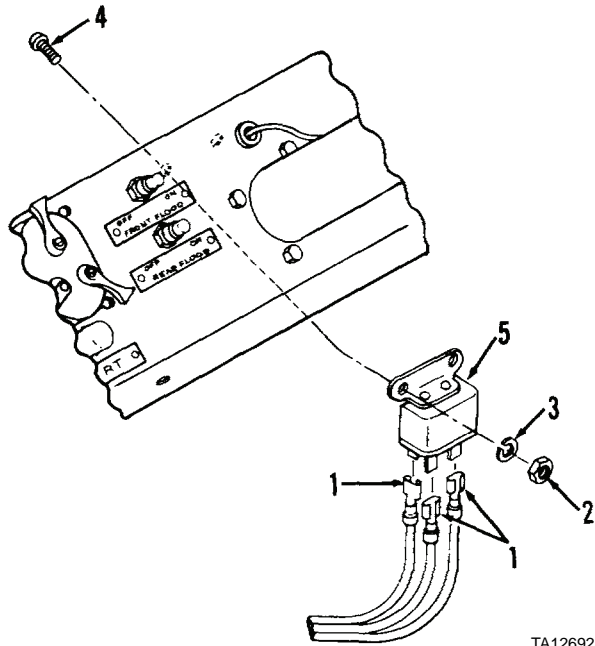

TA126928

**Figure 1. Lock-Out Relay.**

**END OF TASK**

**CLEANING****WARNING**

- Solvent cleaning compound MIL-PRF-680 Type III is an environmentally compliant and low toxic material. However, it may be irritating to the eyes and skin. Use protective gloves and goggles. Use in well-ventilated areas. Keep away from open flames and other sources of ignition. Failure to do so may result in injury or death to personnel.
  - Particles blown by compressed air are hazardous. DO NOT exceed 15 PSI (103 kPa) nozzle pressure when drying parts with compressed air. DO NOT direct compressed air against human skin. Make sure air stream is directed away from user and other personnel in the area. To prevent injury, user must wear protective goggles or face shield. Failure to follow this warning may result in injury to personnel.
1. Use solvent cleaning compound to clean all hardware. Dry thoroughly with compressed air.
  2. Clean wire connectors and relay terminals. Use solvent cleaning compound on connectors and terminals only.

**END OF TASK****INSPECTION**

1. Inspect nut (Figure 1, Item 2) and screw (Figure 1, Item 4). Replace if threads damaged.
2. Inspect harness wires. Replace if insulation frayed, or if conductors broken.
3. Inspect lock-out relay (Figure 1, Item 5). Replace if terminals damaged.

**END OF TASK****INSTALLATION**

1. Position lock-out relay (Figure 1, Item 5) against instrument panel.
2. Install two screws (Figure 1, Item 4), new lockwashers (Figure 1, Item 3), and nuts (Figure 1, Item 2) and tighten screws until lock-out relay (Figure 1, Item 5) is securely mounted.
3. Connect wire leads (Figure 1, Item 1) to relay terminals.

**END OF TASK****END OF WORK PACKAGE**





---

## ORGANIZATIONAL MAINTENANCE INSTRUCTIONS

### WARNING LIGHTS AND DIODES MAINTENANCE

#### Removal, Cleaning, Inspection, Testing, Installation

---

#### INITIAL SETUP

##### Maintenance Level

Organizational

##### Tools and Special Tools

Tool kit, general mechanic's (Item 15, WP 0309)

Shop equipment, common no. 1 (Item 2, WP 0309)

##### Materials/Parts

Cleaning compound, solvent (Item 10, WP 0310)

Rag, wiping (Item 26, WP 0310)

##### Materials/Parts - Continued

RTV sealant (Item 31, WP 0310)

Strap, tiedown (Item 32, WP 0310)

##### References

WP 0093

##### Equipment Condition

Engine OFF

Ignition switch in OFF position and key removed

Noise baffle mat removed (WP 0187)

---

**REMOVAL****NOTE**

All five warning light assemblies are identical except for legend marked on lens. Isolation diode for alternator warning light is located in engine compartment (WP 0093). Isolation diode is not used with oil pressure warning light.

1. Disconnect wire leads (Figure 1, Item 1) from warning light terminals.
2. Push socket (Figure 1, Item 2) against instrument panel.
3. Support socket (Figure 1, Item 2) and rotate lens (Figure 1, Item 3) 1/4 turn to remove from instrument panel.
4. Remove socket (Figure 1, Item 2) from instrument panel.
5. Remove bulb (Figure 1, Item 4) from socket (2).
6. Remove isolation diode (Figure 1, Item 6) from connector (Figure 1, Item 5).

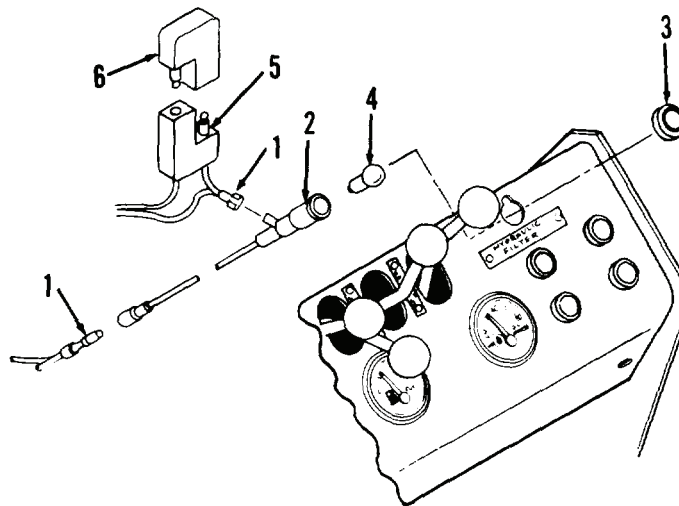

TA126929

**Figure 1. Warning Light and Diode.**

**END OF TASK****CLEANING****WARNING**

Solvent cleaning compound MIL-PRF-680 Type III is an environmentally compliant and low toxic material. However, it may be irritating to the eyes and skin. Use protective gloves and goggles. Use in well-ventilated areas. Keep away from open flames and other sources of ignition. Failure to do so may result in injury or death to personnel.

1. Clean electrical connectors and terminals (Figure 1, Items 1, 2, 5, and 6). Use solvent cleaning compound on connectors and terminals only.
2. Use clean, dry rag to clean lens (Figure 1, Item 3).

**END OF TASK****INSPECTION**

Inspect harness, connector, and light assembly wires. Replace if insulation frayed, or if conductors broken.

**END OF TASK****TESTING**

1. Set ohmmeter to lowest resistance range, connect leads to terminals of diode (Figure 1, Item 6), and note reading.
2. Reverse leads and note reading. There should be one low and one high reading. Replace diode if readings are both low, both high, or identical.

**END OF TASK****INSTALLATION**

1. Connect connector (Figure 1, Item 5) of isolation diode (Figure 1, Item 6).
2. Install bulb (Figure 1, Item 4) in socket (Figure 1, Item 2).
3. Position socket (Figure 1, Item 2) from below instrument panel.
4. Position lens (Figure 1, Item 3) on instrument panel top.
5. Connect socket (Figure 1, Item 2) and lens (Figure 1, Item 3) while rotating lens 1/4 turn to secure socket (Figure 1, Item 2).
6. Connect wire leads (Figure 1, Item 1) to warning light terminals.

**END OF TASK****END OF WORK PACKAGE**



---

## ORGANIZATIONAL MAINTENANCE INSTRUCTIONS

### SLAVE RECEPTACLE REPLACEMENT

Removal, Cleaning, Inspection, Installation/Replacement

---

#### INITIAL SETUP

##### Maintenance Level

Organizational

##### Tools and Special Tools

Tool kit, general mechanic's (Item 15, WP 0309)

Shop equipment, common no. 1 (Item 2, WP 0309)

##### Materials/Parts

Cleaning compound, solvent (Item 10, WP 0310)

##### Materials/Parts - Continued

Rag, wiping (Item 26, WP 0310)

RTV sealant (Item 31, WP 0310)

##### Equipment Condition

Engine OFF

Battery ground cable disconnected (WP 0133 or  
WP 0134)

Left side panel removed (WP 0179)

Left hood support plate removed (WP 0182 or  
WP 0183)

---

**REMOVAL**

1. Remove two capscrews (Figure 1, Item 1) and cables (Figure 1, Items 2 and 3) from slave receptacle (Figure 1, Item 7).
2. Support slave receptacle (Figure 1, Item 7) and remove four nuts (Figure 1, Item 4), flat washers (Figure 1, Item 5), and screws (Figure 1, Item 6).
3. Remove slave receptacle (Figure 1, Item 7) and rubber insulators (Figure 1, Items 8 and 9) from left side panel.
4. Remove cover (Figure 1, Item 10) from slave receptacle (Figure 1, Item 7).

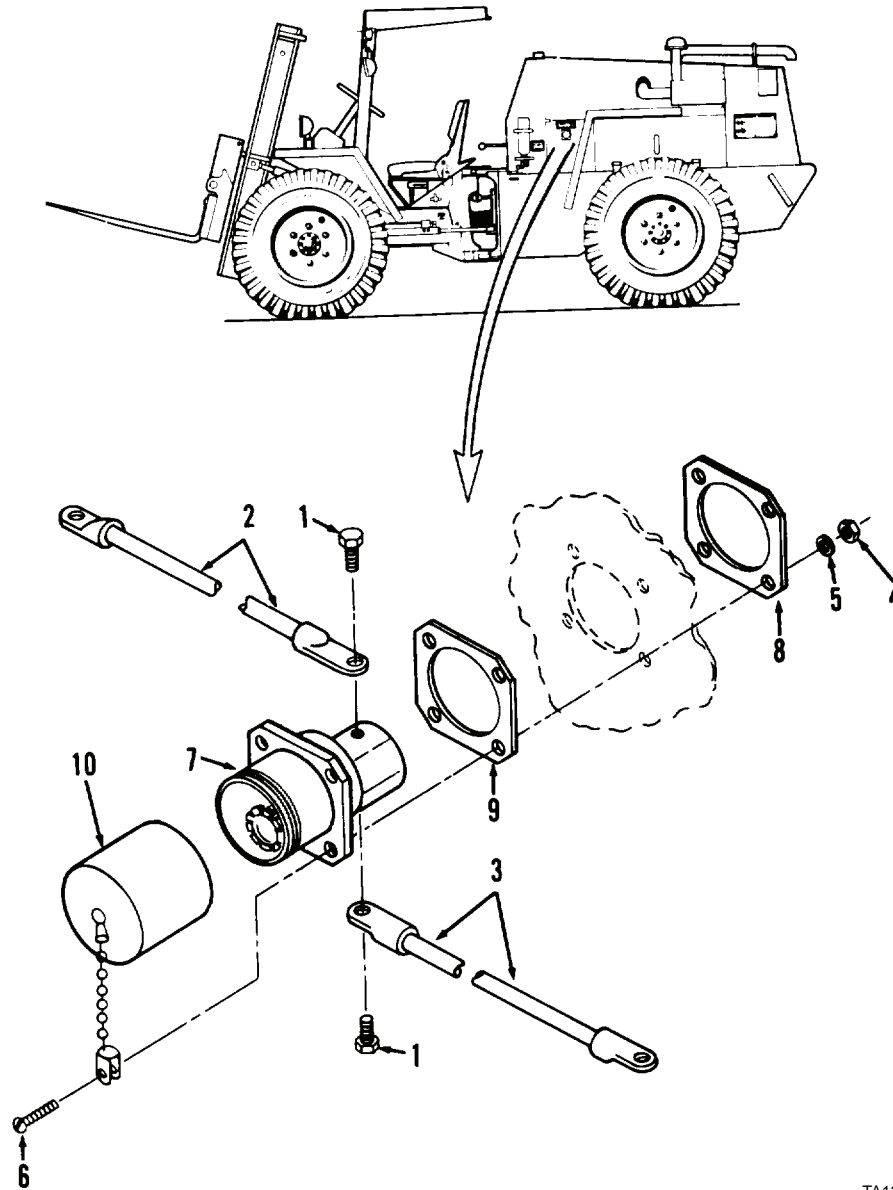

Figure 1. Slave Receptacle.

TA126930

END OF TASK

**CLEANING****WARNING**

- Solvent cleaning compound MIL-PRF-680 Type III is an environmentally compliant and low toxic material. However, it may be irritating to the eyes and skin. Use protective gloves and goggles. Use in well-ventilated areas. Keep away from open flames and other sources of ignition. Failure to do so may result in injury or death to personnel.
  - Particles blown by compressed air are hazardous. DO NOT exceed 15 PSI (103 kPa) nozzle pressure when drying parts with compressed air. DO NOT direct compressed air against human skin. Make sure air stream is directed away from user and other personnel in the area. To prevent injury, user must wear protective goggles or face shield. Failure to follow this warning may result in injury to personnel.
1. Clean cable connectors and receptacle terminals. Use solvent cleaning compound on connectors and terminals only.
  2. Use solvent cleaning compound to clean cover (Figure 1, Item 10) and all hardware. Dry thoroughly with compressed air.

**END OF TASK****INSPECTION**

1. Inspect all hardware. Replace if worn, or if threads damaged.
2. Inspect cables (Figure 1, Items 2 and 3). Replace if insulation frayed, or if conductors broken.
3. Inspect slave receptacle (Figure 1, Item 7) and cover (Figure 1, Item 10). Replace if threads damaged, or if slave receptacle terminals damaged.
4. Inspect rubber insulators (Figure 1, Items 8 and 9). Replace if cracked or deteriorated.

**END OF TASK****INSTALLATION/REPLACEMENT**

1. Install cover (Figure 1, Item 10) on receptacle (Figure 1, Item 7) at left hood support.
2. Position rubber insulators (Figure 1, Items 8 and 9) and receptacle (Figure 1, Item 7) on left side panel.
3. Install four screws (Figure 1, Item 6), flat washers (Figure 1, Item 5), and nuts (Figure 1, Item 4) and tighten nuts.
4. Install cables (Figure 1, Items 2 and 3) and two capscrews (Figure 1, Item 1) on receptacle (Figure 1, Item 7). Tighten capscrews.
5. Use silicone rubber sealer to seal cable connectors and cap screws (Figure 1, Item 1).

**END OF TASK****END OF WORK PACKAGE**





---

# ORGANIZATIONAL MAINTENANCE INSTRUCTIONS

## HOURMETER REPLACEMENT

### Removal, Cleaning, Inspection, Installation

---

#### INITIAL SETUP

##### Maintenance Level

Organizational

##### Tools and Special Tools

Tool kit, general mechanic's (Item 15, WP 0309)

Shop equipment, common no. 1 (Item 2, WP 0309)

##### Materials/Parts

Cleaning compound, solvent (Item 10, WP 0310)

##### Materials/Parts - Continued

Rag, wiping (Item 26, WP 0310)

RTV sealant (Item 31, WP 0310)

Tag, marker (Item 33, WP 0310)

Lockwasher

##### Equipment Condition

Engine OFF

Ignition switch in OFF position and key removed

Left side panel removed (WP 0179)

---

**NOTE**

Tag all electrical leads.

**REMOVAL**

1. Disconnect wire leads (Figure 1, Items 1 and 2) from hourmeter (Figure 1, Item 5).
2. Support hourmeter (Figure 1, Item 5) and remove two wing nuts (Figure 1, Item 3) and bracket (Figure 1, Item 4).
3. Remove hourmeter (Figure 1, Item 5) from left side panel.
4. Remove nut (Figure 1, Item 6), lockwasher (Figure 1, Item 7), and capscrew (Figure 1, Item 8) from left side fender. Discard lockwasher.

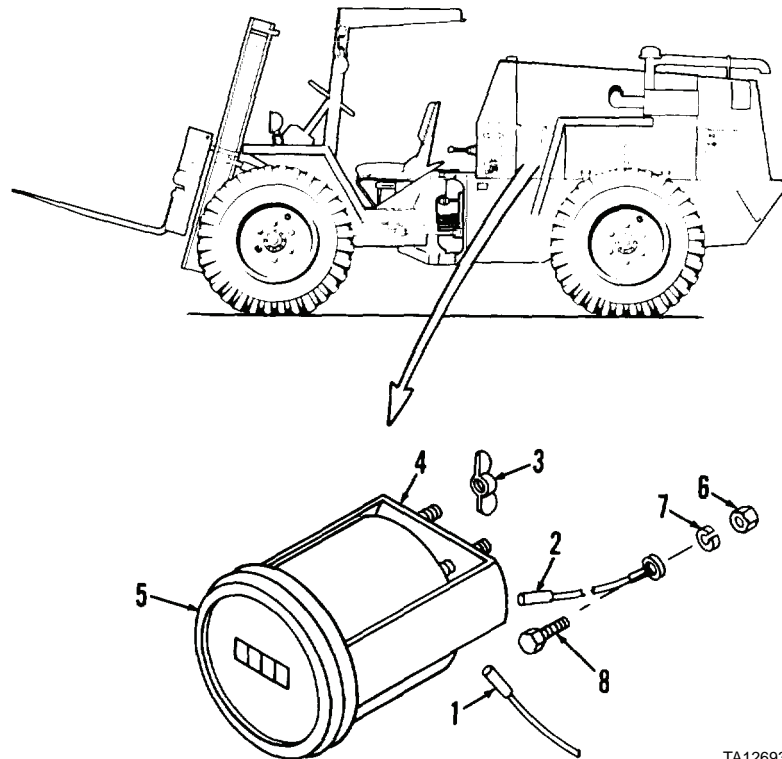

TA126931

Figure 1. Hourmeter.

**END OF TASK**

**CLEANING****WARNING**

- Solvent cleaning compound MIL-PRF-680 Type III is an environmentally compliant and low toxic material. However, it may be irritating to the eyes and skin. Use protective gloves and goggles. Use in well-ventilated areas. Keep away from open flames and other sources of ignition. Failure to do so may result in injury or death to personnel.
  - Particles blown by compressed air are hazardous. DO NOT exceed 15 PSI (103 kPa) nozzle pressure when drying parts with compressed air. DO NOT direct compressed air against human skin. Make sure air stream is directed away from user and other personnel in the area. To prevent injury, user must wear protective goggles or face shield. Failure to follow this warning may result in injury to personnel.
1. Clean wire connectors and hourmeter terminals. Use solvent cleaning compound on connectors and terminals only.
  2. Use solvent cleaning compound to clean bracket (Figure 1, Item 4) and all hardware. Dry thoroughly with compressed air.

**END OF TASK****INSPECTION**

1. Inspect all hardware. Replace if worn, or if threads damaged.
2. Inspect positive wire and ground wire. Replace if insulation frayed, or if conductors broken.
3. Inspect hourmeter. Replace if threads damaged, or if receptacle terminals damaged.
4. Inspect bracket (Figure 1, Item 4). Replace hourmeter if bracket is cracked or damaged.

**END OF TASK****INSTALLATION**

1. Position ground wire and lead (Figure 1, Item 2) inside left fender bolt hole.
2. Install capscrew (Figure 1, Item 8), new lockwasher (Figure 1, Item 7), and nut (Figure 1, Item 6). Tighten nut.
3. Position hourmeter (Figure 1, Item 5) on left side panel.
4. Position bracket (Figure 1, Item 4) on hourmeter studs.
5. Tighten two wing nuts (Figure 1, Item 3) evenly until hourmeter (Figure 1, Item 5) is securely mounted.
6. Connect wire leads (Figure 1, Items 1 and 2) to hourmeter (Figure 1, Item 5).
7. Use silicone rubber sealer to seal all leads and terminals.

**END OF TASK****END OF WORK PACKAGE**



---

## ORGANIZATIONAL MAINTENANCE INSTRUCTIONS

### FLOODLIGHTS MAINTENANCE (MODEL 207)

Removal, Cleaning, Inspection, Installation/Replacement, Testing

---

#### INITIAL SETUP

##### Maintenance Level

Organizational

##### Tools and Special Tools

Tool kit, general mechanic's (Item 15, WP 0309)

Shop equipment, common no. 1 (Item 2, WP 0309)

##### Materials/Parts

Cleaning compound, solvent (Item 10, WP 0310)

Rag, wiping (Item 26, WP 0310)

##### Materials/Parts - Continued

Tag, marker (Item 33, WP 0310)

Lockwasher

##### References

WP 0017

##### Equipment Condition

Engine OFF

Ignition switch in OFF position and key removed

Tow bar lowered to ground and grille opened  
(WP 0176)

---

**NOTE**

Tag all electrical leads.

**REMOVAL**

1. Pull inserts from cutouts in housing (Figure 1, Item 9).
2. Remove rubber gasket (Figure 1, Item 1) from housing (Figure 1, Item 9) and lamp (Figure 1, Item 3).
3. Remove wire leads (Figure 1, Item 2) from lamp (Figure 1, Item 3) and set lamp aside.
4. Remove connector (Figure 1, Item 4) from harness lead.

**NOTE**

Seal is not used on instrument panel-mounted floodlights or rear floodlights.

5. Remove seal (Figure 1, Item 5) from nut (Figure 1, Item 6).
6. Support housing (Figure 1, Item 9) and remove nut (Figure 1, Item 6), lockwasher (Figure 1, Item 7), and washer (Figure 1, Item 11). Discard lockwasher.

**NOTE**

Seal is not used on instrument panel-mounted floodlights.

7. Remove housing (Figure 1, Item 9) spacer, and seal (Figure 1, Item 8) from vehicle.
8. Remove grommet (Figure 1, Item 10) from ROPS.

**END OF TASK****CLEANING****WARNING**

- Solvent cleaning compound MIL-PRF-680 Type III is an environmentally compliant and low toxic material. However, it may be irritating to the eyes and skin. Use protective gloves and goggles. Use in well-ventilated areas. Keep away from open flames and other sources of ignition. Failure to do so may result in injury or death to personnel.
  - Particles blown by compressed air are hazardous. DO NOT exceed 15 PSI (103 kPa) nozzle pressure when drying parts with compressed air. DO NOT direct compressed air against human skin. Make sure air stream is directed away from user and other personnel in the area. To prevent injury, user must wear protective goggles or face shield. Failure to follow this warning may result in injury to personnel.
1. Clean wire connectors and terminals. Use solvent cleaning compound on connectors and terminals only.
  2. Wipe gasket (Figure 1, Item 1), seals (Figure 1, Items 5 and 8), and grommet (Figure 1, Item 10) with a clean, dry rag.
  3. Use solvent cleaning compound to clean housing (Figure 1, Item 9) and hardware (Figure 1, Items 6, 7, and 11). Dry thoroughly with compressed air.

**END OF TASK**

**INSPECTION**

1. Inspect all hardware. Replace if worn, or if threads damaged.
2. Inspect all wiring. Replace if insulation frayed, or if conductors broken.
3. Inspect rubber gasket (Figure 1, Item 1), seals (Figure 1, Items 5 and 8), and grommet (Figure 1, Item 10). Replace if cracked or deteriorated.
4. Inspect housing (Figure 1, Item 9). Replace if cracked or if threads damaged.

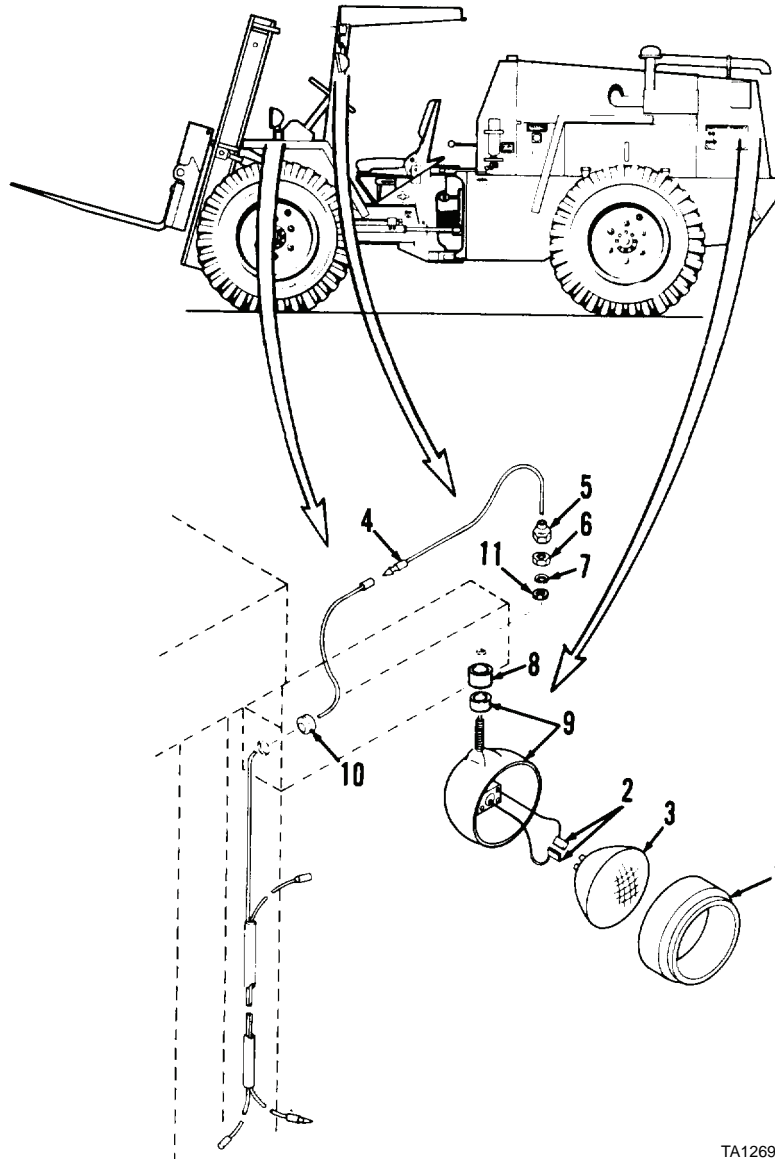

TA126932

**Figure 1. Floodlight.****END OF TASK**

---

**INSTALLATION/REPLACEMENT**

1. Slide grommet (Figure 2, Item 10) over harness lead and install on ROPS.

**NOTE**

- Mark a spot for a drain hole on bottom of housing. Using 1/4 in. drill bit, drill hole at mark. Apply paint around hole to stop rust and corrosion.
  - Seal not used on instrument panel-mounted floodlights.
2. Position seal (Figure 2, Item 8), housing (Figure 2, Item 9), and spacer on vehicle.

**NOTE**

Seal used on ROPS-mounted floodlights only.

3. Slide washer (Figure 2, Item 11), new lockwasher (Figure 2, Item 7), nut (Figure 2, Item 6), and seal (Figure 2, Item 5) over connector (Figure 2, Item 4) and tighten nut until floodlight housing (Figure 2, Item 9) is securely mounted.
4. Connect connector (Figure 2, Item 4) to harness lead.
5. Install rubber gasket (Figure 2, Item 1) over lamp (Figure 2, Item 3).
6. Connect wire leads (Figure 2, Item 2) to lamp terminals.
7. Push rubber tangs of gasket (Figure 2, Item 1) into cutouts in housing (Figure 2, Item 9). Use a screwdriver to fully position tangs if necessary.



## INSTALLATION/REPLACEMENT - CONTINUED

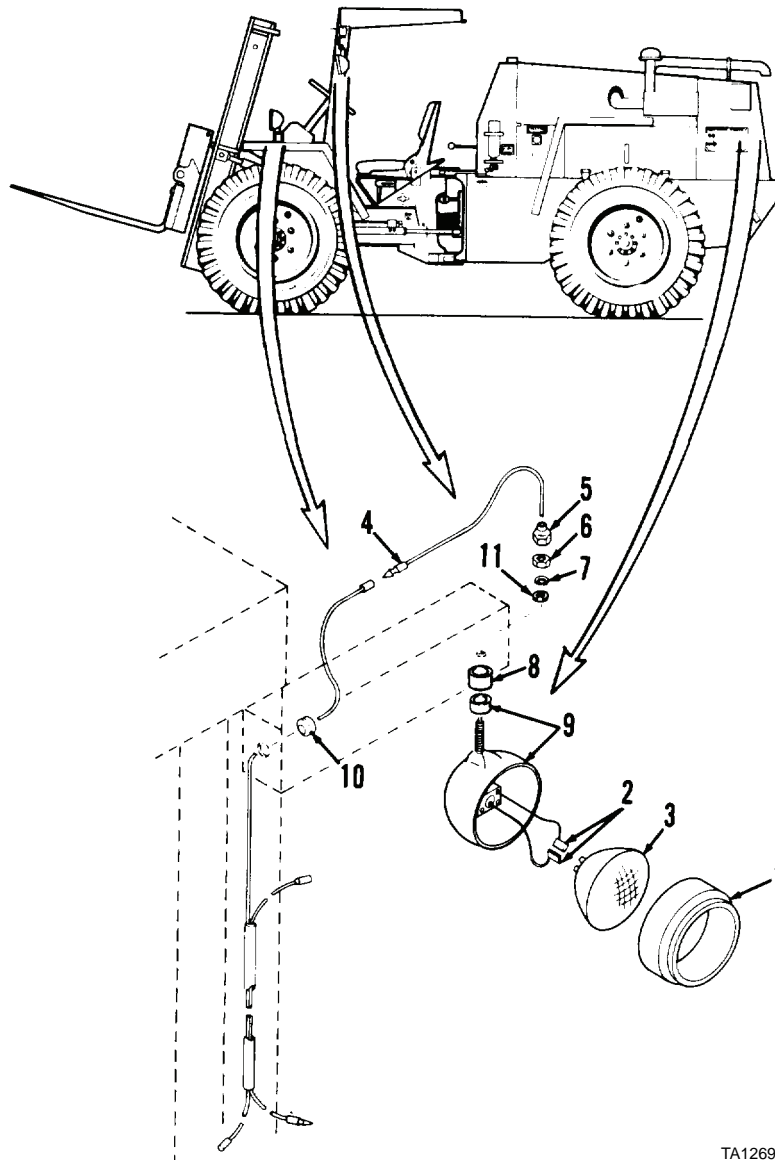

TA126932

Figure 2. Floodlight.

## END OF TASK

## TESTING

1. Place ignition switch in ON position.
2. Place vehicle lights switch in SER. DRIVE position.
3. Place front flood switch or rear flood switch in ON position as appropriate.
4. Front or rear floodlights should be on. If floodlights are on, place ignition, front flood or rear flood, and vehicle lights switches in OFF positions. If floodlights are not on, refer to WP 0017 and troubleshoot light systems.

## END OF TASK

## END OF WORK PACKAGE



## ORGANIZATIONAL MAINTENANCE INSTRUCTIONS

### FLOODLIGHTS MAINTENANCE (MODEL 4-390)

Removal, Disassembly, Cleaning, Inspection, Assembly, Installation

#### INITIAL SETUP

##### Maintenance Level

Organizational

##### Tools and Special Tools

Tool kit, general mechanic's (Item 15, WP 0309)

##### Materials/Parts

Detergent, liquid (Item 13, WP 0310)

##### Materials/Parts - Continued

Rag, wiping (Item 26, WP 0310)

Lockwasher

Star washer

Water

##### Equipment Condition

Vehicle parked on level surface

Engine OFF

#### NOTE

Perform the following steps to remove each of six floodlights from vehicles.

#### REMOVAL

1. Disconnect connector (Figure 1, Item 1) of floodlight housing (Figure 1, Item 2) from connector of front wiring harness.
2. Remove nut (Figure 1, Item 3), lockwasher (Figure 1, Item 4), star washer (Figure 1, Item 5), ring (Figure 1, Item 6), and floodlight housing (Figure 1, Item 2) from vehicle. Discard lockwasher and star washer.

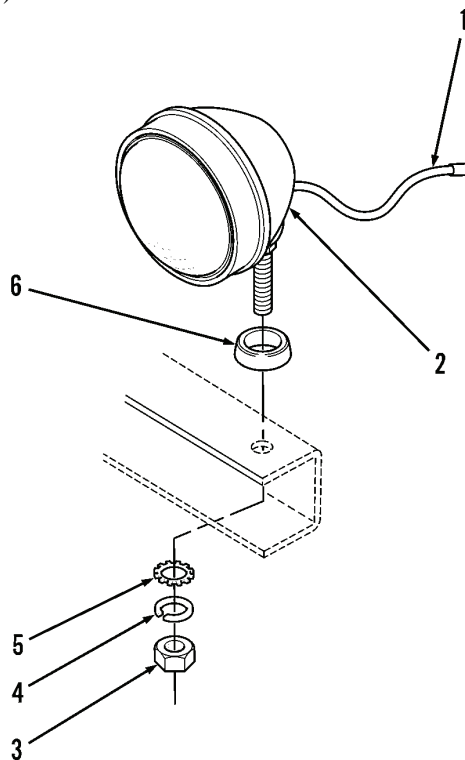

444-0388

Figure 1. Floodlight and Associated Parts.

END OF TASK

**DISASSEMBLY**

1. Carefully pry lamp (Figure 2, Item 7) out of floodlight housing (Figure 2, Item 2).
2. Extend lamp (Figure 2, Item 7) outward from floodlight housing (Figure 2, Item 2) and disconnect two connectors (Figure 2, Item 8) from terminals of lamp.

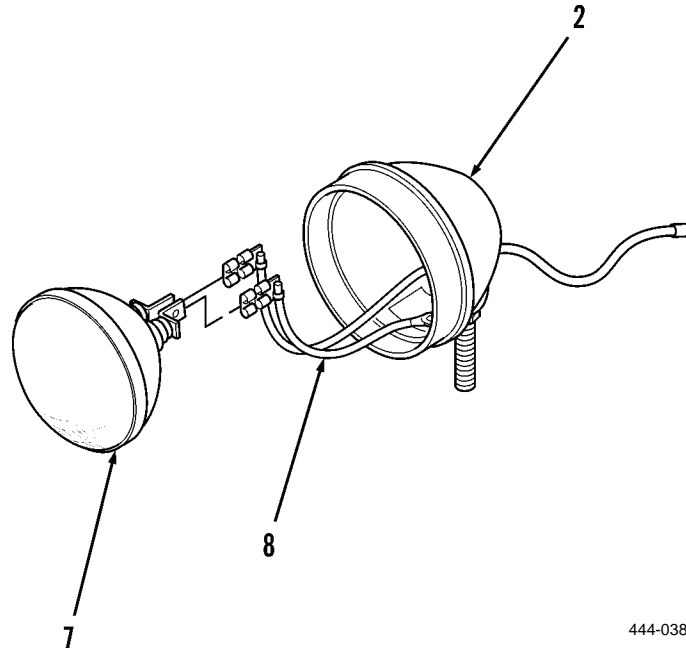

444-0389

**Figure 2. Floodlight Assembly.****END OF TASK****CLEANING**

Clean all parts by wiping with clean rag moistened with detergent and water.

**END OF TASK****INSPECTION**

1. Inspect floodlight housing. Replace if cracked or damaged.
2. Inspect wires of floodlight housing. Repair wires if insulation is missing or connectors are damaged or corroded.
3. Inspect lamp. Replace if broken, interior is blackened, or lamp is defective.

**END OF TASK****ASSEMBLY**

1. Connect two connectors (Figure 2, Item 8) of floodlight housing (Figure 2, Item 2) to terminals of lamp (Figure 2, Item 7).
2. Carefully press lamp (Figure 2, Item 6) into floodlight housing (Figure 2, Item 2) until fully seated.

**END OF TASK**

**INSTALLATION****NOTE**

Perform the following steps to install each of six floodlights in vehicle.

1. Install floodlight housing (Figure 3, Item 2) and ring (Figure 3, Item 6) on vehicle with new star washer (Figure 3, Item 5), new lockwasher (Figure 3, Item 4), and nut (Figure 3, Item 3).
2. Connect connector (Figure 3, Item 1) of floodlight housing (Figure 3, Item 2) to connector of front wiring harness.

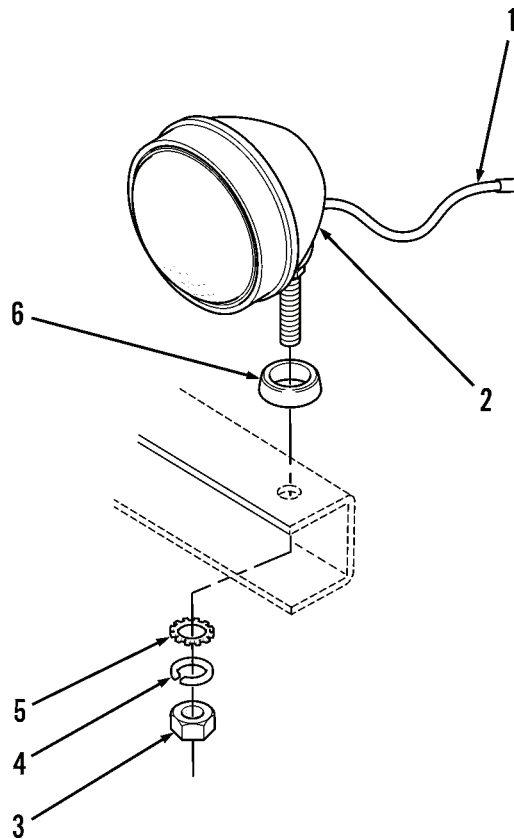

444-0388

**Figure 3. Floodlight and Associated Parts.**

**END OF TASK**

**END OF WORK PACKAGE**



---

## ORGANIZATIONAL MAINTENANCE INSTRUCTIONS

### FRONT BLACKOUT LIGHT MAINTENANCE

Removal, Cleaning, Inspection, Installation/Replacement, Testing

---

#### INITIAL SETUP

##### Maintenance Level

Organizational

##### Tools and Special Tools

Tool kit, general mechanic's (Item 15, WP 0309)

Shop equipment, common no. 1 (Item 2, WP 0309)

##### Materials/Parts

Cleaning compound, solvent (Item 10, WP 0310)

Rag, wiping (Item 26, WP 0310)

##### Materials/Parts - Continued

Lockwasher

##### References

WP 0017

##### Equipment Condition

Engine OFF

Ignition switch in OFF position and key removed

Tow bar lowered to ground and grille opened  
(WP 0176)

---

#### NOTE

Two different blackout lights are used; one type uses bulb; the other type uses lamp unit.

**REMOVAL**

1. Loosen three screws (Figure 1, Item 1) and lockwasher (Figure 1, Item 2) if equipped and remove door (Figure 1, Item 3) from body (Figure 1, Item 9).
2. Depress bulb (Figure 1, Item 5), turn counterclockwise, and remove.
3. Remove three springs (Figure 1, Item 4) and lamp unit (Figure 1, Item 11) from body (Figure 1, Item 9).
4. Remove washer (Figure 1, Item 12) and shell (Figure 1, Item 14) from wire leads (Figure 1, Item 13).
5. Remove harness lead (Figure 1, Item 6) from connector (Figure 1, Item 15).

**NOTE**

Model 4-390 also utilizes a star washer between lockwasher and ROPS frame.

6. Remove nut (Figure 1, Item 7) and lockwasher (Figure 1, Item 8) from body (Figure 1, Item 9). Discard lockwasher.
7. Remove body (Figure 1, Item 9) from ROPS.
8. Remove connector (Figure 1, Item 15) and grommet (Figure 1, Item 16) from body (Figure 1, Item 9).

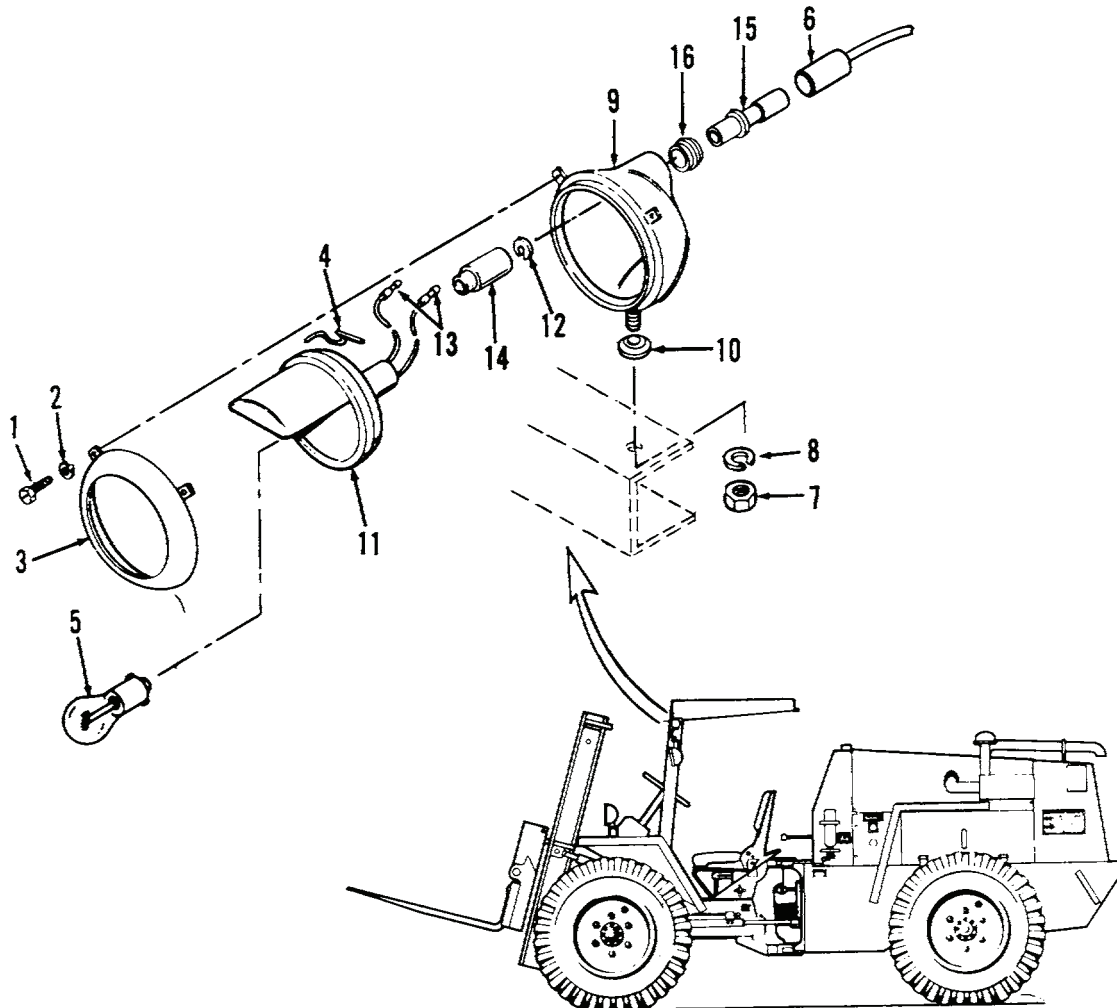

TA126933

**Figure 1. Front Blackout Light Assembly.**

**END OF TASK**



**CLEANING**

- Solvent cleaning compound MIL-PRF-680 Type III is an environmentally compliant and low toxic material. However, it may be irritating to the eyes and skin. Use protective gloves and goggles. Use in well-ventilated areas. Keep away from open flames and other sources of ignition. Failure to do so may result in injury or death to personnel.
  - Particles blown by compressed air are hazardous. DO NOT exceed 15 PSI (103 kPa) nozzle pressure when drying parts with compressed air. DO NOT direct compressed air against human skin. Make sure air stream is directed away from user and other personnel in the area. To prevent injury, user must wear protective goggles or face shield. Failure to follow this warning may result in injury to personnel.
1. Clean wire connectors. Use solvent cleaning compound on connectors only.
  2. Use solvent cleaning compound to clean door (Figure 1, Item 3), lamp unit (Figure 1, Item 11), body (Figure 1, Item 9), and hardware. Dry thoroughly with compressed air.
  3. Wipe shell (Figure 1, Item 14) and grommet (Figure 1, Item 16) with a clean, dry rag.

**END OF TASK****INSPECTION**

1. Inspect all hardware. Replace if worn, or if threads damaged.
2. Inspect all wiring. Replace if insulation frayed, or if conductors broken.
3. Inspect door (Figure 1, Item 3), body (Figure 1, Item 9), and lamp unit (Figure 1, Item 11). Replace if cracked or damaged.
4. Inspect shell (Figure 1, Item 14), connector (Figure 1, Item 15), and grommet (Figure 1, Item 16). Replace if cracked, damaged, or deteriorated.

**END OF TASK**

**INSTALLATION/REPLACEMENT**

1. Install grommet (Figure 2, Item 16) and connector (Figure 2, Item 15) in body (Figure 2, Item 9).
2. Position body (Figure 2, Item 9) and washer (Figure 2, Item 10) on ROPS.
3. Install star washer (if equipped), new lockwasher (Figure 2, Item 8), and nut (Figure 2, Item 7) and tighten nut until blackout light is securely mounted.
4. Connect harness lead (Figure 2, Item 6) to connector (Figure 2, Item 15).
5. Install shell (Figure 2, Item 14) and washer (Figure 2, Item 12) on wire leads (Figure 2, Item 13).
6. Install lamp unit (Figure 2, Item 11) and three springs (Figure 2, Item 4).
7. Install bulb (Figure 2, Item 5) in body (Figure 2, Item 9).
8. Position door (Figure 2, Item 3) on body (Figure 2, Item 9).
9. Install three lockwashers (Figure 2, Item 2) if equipped and throw screws (Figure 2, Item 1) and tighten screws until door (Figure 2, Item 3) is securely mounted.

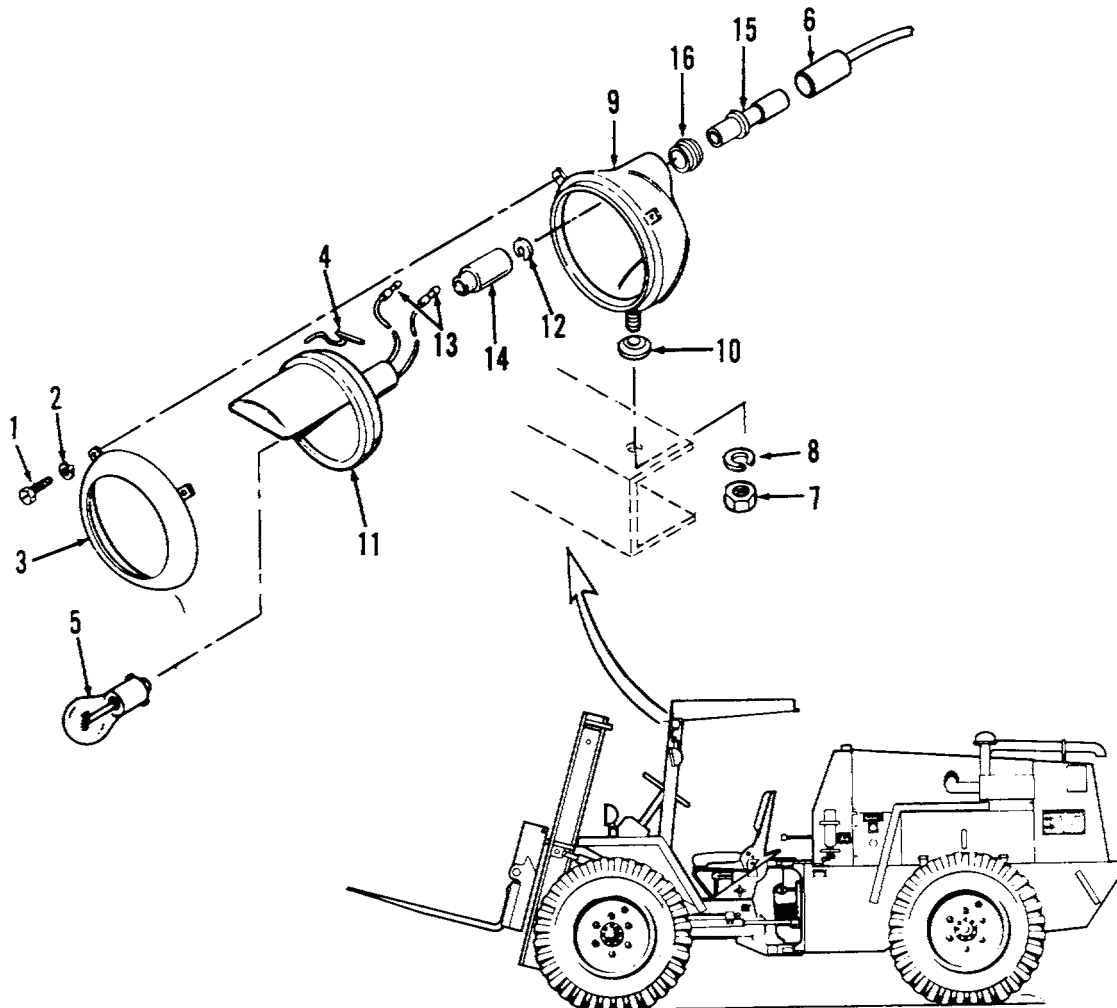

TA126933

**Figure 2. Front Blackout Light Assembly.****END OF TASK**

**TESTING**

1. Place ignition switch in ON position.
2. Place vehicle lights switch in B.O. DRIVE position.
3. Front blackout light should be on; if on, place ignition and vehicle lights switches in OFF positions. If front blackout light is not on, refer to WP 0017.

**END OF TASK****END OF WORK PACKAGE**



---

## ORGANIZATIONAL MAINTENANCE INSTRUCTIONS

### REAR BLACKOUT LIGHTS MAINTENANCE

Removal, Cleaning, Inspection, Installation/Replacement, Testing

---

#### INITIAL SETUP

**Maintenance Level**

Organizational

**Tools and Special Tools**

Tool kit, general mechanic's (Item 15, WP 0309)

Shop equipment, common no. 1 (Item 2, WP 0309)

**Materials/Parts**

Cleaning compound, solvent (Item 10, WP 0310)

Rag, wiping (Item 26, WP 0310)

**Materials/Parts - Continued**

Lockwasher (2)

**References**

WP 0017

**Equipment Condition**

Engine OFF

Ignition switch in OFF position and key removed

Tow bar lowered to ground and grille opened  
(WP 0176)

---

**REMOVAL**

1. Loosen six screws (Figure 1, Item 1) on door (Figure 1, Item 2).
2. Remove door (Figure 1, Item 2) and gasket (Figure 1, Item 3).
3. Remove two bulbs (Figure 1, Item 4) from socket assembly (Figure 1, Item 12).
4. Disconnect harness connectors (Figure 1, Item 6) from light assembly leads.

**NOTE**

Model 4-390 uses flat washers instead of lockwashers.

5. Support body (Figure 1, Item 13) and remove two capscrews (Figure 1, Item 7) and lockwashers (Figure 1, Item 8). Discard lockwashers.
6. Remove body (Figure 1, Item 13) from vehicle.
7. Support socket assembly (Figure 1, Item 12) and remove five screws (Figure 1, Items 9 and 11) and two washers (Figure 1, Item 10).
8. Remove socket assembly (Figure 1, Item 12) from body (Figure 1, Item 13).
9. Remove six rings (Figure 1, Item 5) from screws (Figure 1, Item 1).
10. Remove six screws (Figure 1, Item 1) from door (Figure 1, Item 2).
11. Remove grommet (Figure 1, Item 14) from vehicle.

**END OF TASK****CLEANING****WARNING**

- Solvent cleaning compound MIL-PRF-680 Type III is an environmentally compliant and low toxic material. However, it may be irritating to the eyes and skin. Use protective gloves and goggles. Use in well-ventilated areas. Keep away from open flames and other sources of ignition. Failure to do so may result in injury or death to personnel.
  - Particles blown by compressed air are hazardous. DO NOT exceed 15 PSI (103 kPa) nozzle pressure when drying parts with compressed air. DO NOT direct compressed air against human skin. Make sure air stream is directed away from user and other personnel in the area. To prevent injury, user must wear protective goggles or face shield. Failure to follow this warning may result in injury to personnel.
1. Use solvent cleaning compound to clean body (Figure 1, Item 13) and all hardware. Dry thoroughly with compressed air.
  2. Clean wire connectors. Use solvent cleaning compound on connectors only.
  3. Wipe door (Figure 1, Item 2), gasket (Figure 1, Item 3), and socket assembly (Figure 1, Item 12) with a clean, dry cloth.

CLEANING - CONTINUED

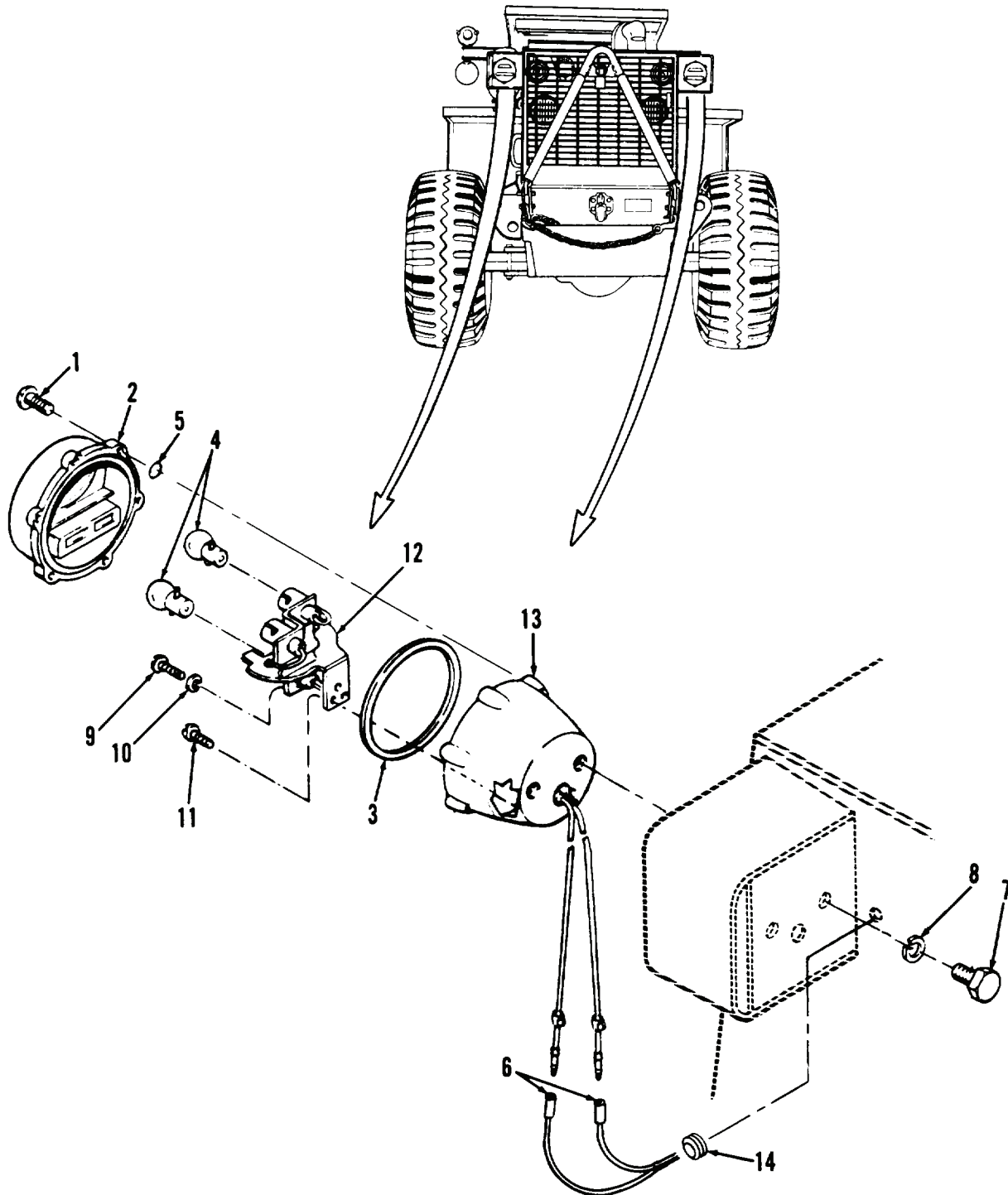

Figure 1. Rear Blackout Light Assembly.

TA126934

END OF TASK

---

**INSPECTION**

1. Inspect all hardware. Replace if worn, or if threads damaged.
2. Inspect all wiring. Replace if insulation frayed, or if conductors broken.
3. Inspect body (Figure 2, Item 13). Replace if cracked, damaged, or if threads damaged.
4. Inspect door (Figure 2, Item 2) and socket assembly (Figure 2, Item 12). Replace if cracked or damaged.
5. Inspect gasket (Figure 2, Item 3) and grommet (Figure 2, Item 14). Replace if cracked or deteriorated.

**END OF TASK****INSTALLATION/REPLACEMENT**

1. Install grommet (Figure 2, Item 14) in rear of vehicle.
2. Position six screws (Figure 2, Item 1) in door (Figure 2, Item 2).
3. Install six rings (Figure 2, Item 5) on screws (Figure 2, Item 1).
4. Position socket assembly (Figure 2, Item 12) in body (Figure 2, Item 13).
5. Install five screws (Figure 2, Items 9 and 11) and two washers (Figure 2, Item 10) and tighten screws until socket assembly (Figure 2, Item 12) is securely mounted.
6. Position body (Figure 2, Item 13) on vehicle.
7. Install two new lockwashers (Figure 2, Item 8) and capscrews (Figure 2, Item 7) and tighten capscrews until body (Figure 2, Item 13) is securely mounted.
8. Connect two harness connectors (Figure 2, Item 6) to light assembly leads.
9. Install two bulbs (Figure 2, Item 4) in socket assembly (Figure 2, Item 12).
10. Position gasket (Figure 2, Item 3) and door (Figure 2, Item 2) on body (Figure 2, Item 13).
11. Tighten six screws (Figure 2, Item 1) until door (Figure 2, Item 2) is securely mounted.

**END OF TASK****TESTING**

1. Place ignition switch in ON position.
2. Place vehicle lights switch in B.O. DRIVE position.
3. Rear blackout lights should be on; have an assistant depress service brake and ensure stop light is on. If on, place ignition and vehicle lights switches in OFF positions. If rear blackout lights and/or stop lights are not on, refer to WP 0017 and troubleshoot light systems.



TESTING - CONTINUED

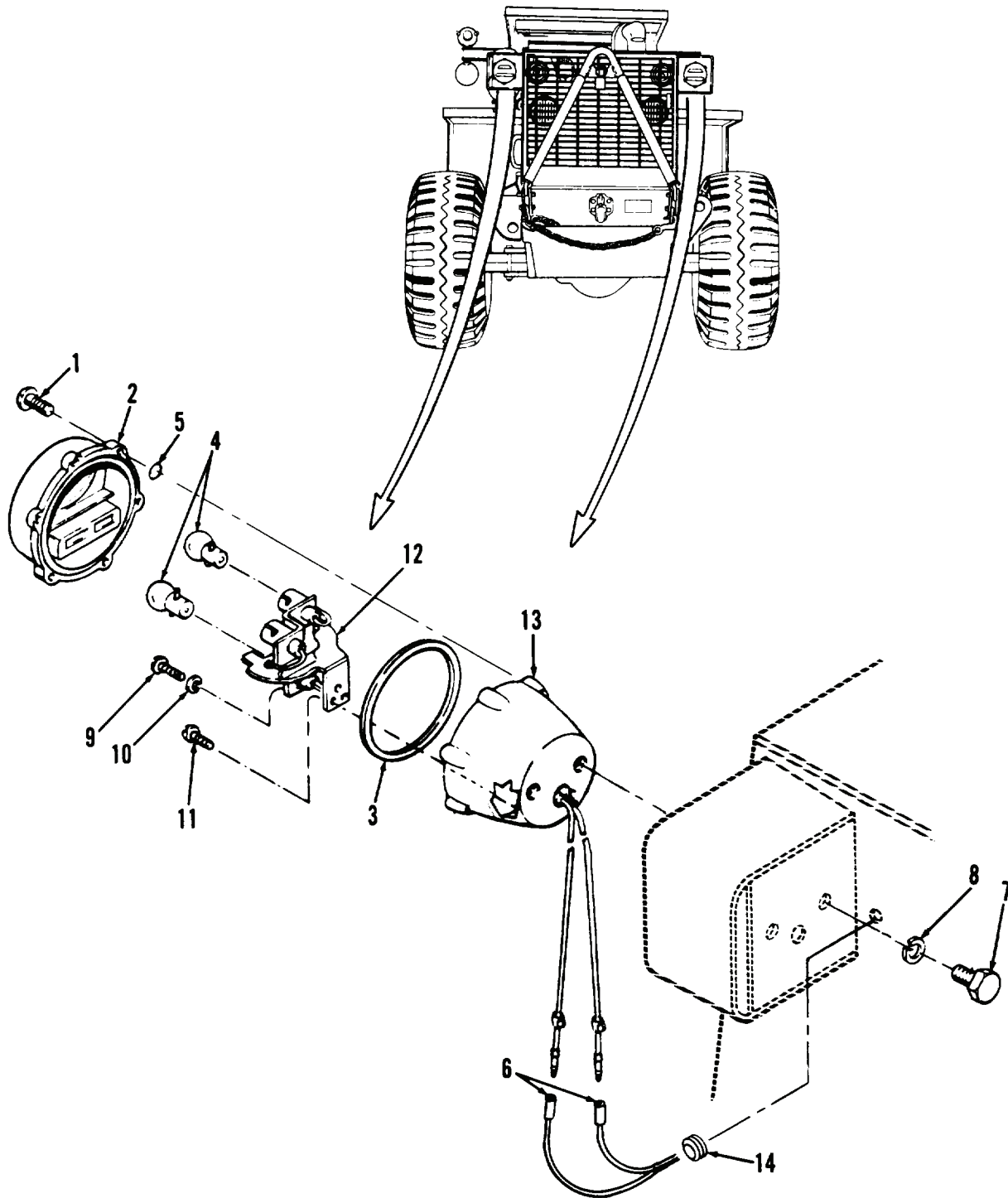

Figure 2. Rear Blackout Light Assembly.

TA126934

END OF TASK

END OF WORK PACKAGE



---

## ORGANIZATIONAL MAINTENANCE INSTRUCTIONS

### STOP AND TAILLIGHTS MAINTENANCE (MODEL 207)

Removal, Cleaning, Inspection, Installation/Replacement, Testing

---

#### INITIAL SETUP

##### Maintenance Level

Organizational

##### Tools and Special Tools

Tool kit, general mechanic's (Item 15, WP 0309)

Shop equipment, common no. 1 (Item 2, WP 0309)

##### Materials/Parts

Cleaning compound, solvent (Item 10, WP 0310)

Rag, wiping (Item 26, WP 0310)

##### Materials/Parts - Continued

Tag, marker (Item 33, WP 0310)

Lockwasher

##### References

WP 0017

##### Equipment Condition

Engine OFF

Ignition switch in OFF position and key removed

Tow bar lowered to ground and grille opened (WP 0176)

---

#### NOTE

Tag all electrical leads.

**REMOVAL**

1. Disconnect two wire leads (Figure 1, Item 1) from harness leads.
2. Remove nut (Figure 1, Item 2) and lockwasher (Figure 1, Item 3) from socket assembly. Discard lockwasher.
3. Remove lens (Figure 1, Item 4) and socket assembly (Figure 1, Item 5) from light bracket.
4. Remove lens (Figure 1, Item 4) by turning counterclockwise and lift from socket assembly (Figure 1, Item 5).
5. Remove lamp (Figure 1, Item 6) from socket assembly (Figure 1, Item 5).

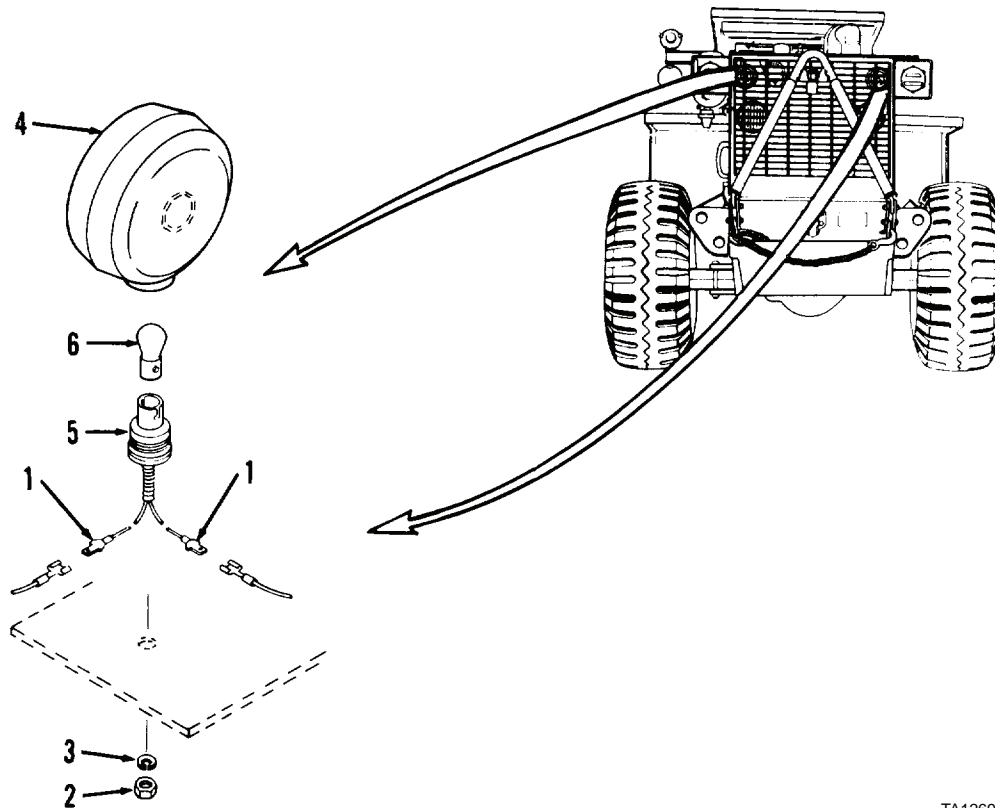

TA126935

**Figure 1. Stop and Taillight.****END OF TASK**

**CLEANING****WARNING**

Solvent cleaning compound MIL-PRF-680 Type III is an environmentally compliant and low toxic material. However, it may be irritating to the eyes and skin. Use protective gloves and goggles. Use in well-ventilated areas. Keep away from open flames and other sources of ignition. Failure to do so may result in injury or death to personnel.

1. Clean socket assembly (Figure 1, Item 5), wire terminals and connectors, and hardware. Use solvent cleaning compound on metal parts only.
2. Inspect all hardware. Replace if worn, or threads damaged.
3. Inspect all wiring. Replace if insulation frayed, or if conductors broken.
4. Inspect lens (Figure 1, Item 4). Replace if cracked or deteriorated.
5. Inspect socket assembly (Figure 1, Item 5). Replace if wires, connectors, or socket damaged.

**END OF TASK****INSTALLATION/REPLACEMENT**

1. Install lamp (Figure 1, Item 6) in socket assembly (Figure 1, Item 5).
2. Install lens (Figure 1, Item 4) in socket assembly (Figure 1, Item 5) hand-tight.
3. Position lens (Figure 1, Item 4) and socket assembly (Figure 1, Item 5) on light bracket.
4. Install new lockwasher (Figure 1, Item 3) and nut (Figure 1, Item 2) and tighten nut until stop and taillight is securely mounted.
5. Connect two wire leads (Figure 1, Item 1) to harness connectors.

**END OF TASK****TESTING**

1. Place ignition switch in ON position.
2. Place vehicle lights switch in SER. DRIVE position.
3. Taillights should be on; have an assistant depress service brake and ensure stop light is on; if lights are on, place ignition and vehicle lights switches in OFF positions. If stop and/or taillights are not on, refer to WP 0017 and troubleshoot light systems.

**END OF TASK****END OF WORK PACKAGE**



---

## ORGANIZATIONAL MAINTENANCE INSTRUCTIONS

### STOP AND TAILLIGHTS MAINTENANCE (MODEL 4-390)

Removal, Disassembly, Cleaning, Inspection, Assembly, Installation

---

#### INITIAL SETUP

**Maintenance Level**

Organizational

**Tools and Special Tools**

Tool kit, general mechanic's (Item 15, WP 0309)

Shop equipment, common no. 1 (Item 2, WP 0309)

**Materials/Parts**

Detergent, liquid (Item 13, WP 0310)

Rag, wiping (Item 26, WP 0310)

Tag, marker (Item 33, WP 0310)

Gasket

**Materials/Parts - Continued**

Lockwasher

Star washer

Water

**References**

WP 0017

**Equipment Condition**

Vehicle parked on level surface

Engine OFF

Tow bar lowered to ground and grille opened  
(WP 0176)

---

#### NOTE

- Tag all electrical leads before disconnecting.
- Perform the following steps to remove each of two stop and taillights from vehicle.

**REMOVAL**

1. Disconnect two wire connectors (Figure 1, Item 1) of stop and taillight housing (Figure 1, Item 2) from two connectors of rear wiring harness.
2. Remove nut (Figure 1, Item 3), lockwasher (Figure 1, Item 4), star washer (Figure 1, Item 5), and stop and taillight housing (Figure 1, Item 2) from vehicle. Discard lockwasher and star washer.

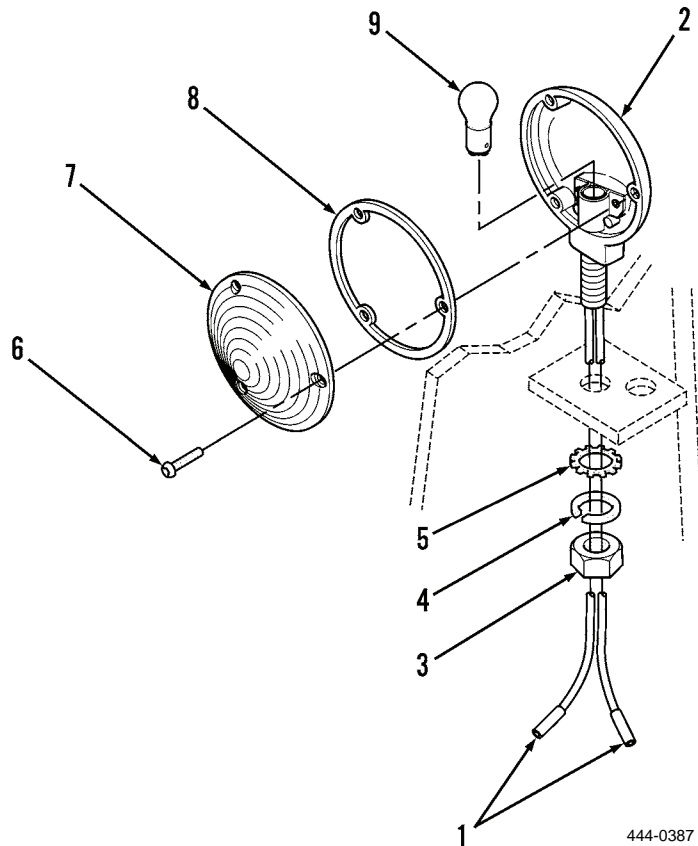
**Figure 1. Stop and Taillight.****END OF TASK****DISASSEMBLY**

1. Remove three screws (Figure 1, Item 6), lens (Figure 1, Item 7), and gasket (Figure 1, Item 8) from stop and taillight housing (Figure 1, Item 2). Discard gasket.
2. Press downward, rotate, and remove lamp (Figure 1, Item 9) from socket of stop and taillight housing (Figure 1, Item 2).

**END OF TASK**



**CLEANING**

Clean all parts by wiping with clean rag moistened with detergent and water.

**END OF TASK****INSPECTION**

1. Inspect stop and taillight housing. Replace if cracked or damaged.
2. Inspect wires of stop and taillight housing. Repair wires if insulation is missing or connectors are damaged or corroded.
3. Inspect lamp. Replace if broken, interior is blackened, or lamp is defective.

**END OF TASK****ASSEMBLY**

1. Install lamp (Figure 1, Item 9) in socket of stop and taillight housing (Figure 1, Item 2) by pressing downward, rotating, and releasing.
2. Install new gasket (Figure 1, Item 8) and lens (Figure 1, Item 7) on stop and taillight housing (Figure 1, Item 2) with three screws (Figure 1, Item 6).

**END OF TASK****INSTALLATION****NOTE**

Perform the following steps to install each of two stop and taillights on vehicle.

1. Install stop and taillight housing (Figure 1, Item 2) on vehicle with new star washer (Figure 1, Item 5), new lockwasher (Figure 1, Item 4), and nut (Figure 1, Item 3).
2. Connect two connectors (Figure 1, Item 1) of stop and taillight housing (Figure 1, Item 2) to two connectors of rear wiring harness.

**END OF TASK****END OF WORK PACKAGE**



---

## ORGANIZATIONAL MAINTENANCE INSTRUCTIONS

### FUEL GAGE SENDING UNIT REPLACEMENT

Removal, Cleaning, Inspection, Installation

---

#### INITIAL SETUP

##### Maintenance Level

Organizational

##### Tools and Special Tools

Tool kit, general mechanic's (Item 15, WP 0309)

Shop equipment, common no. 1 (Item 2, WP 0309)

##### Materials/Parts

Cleaning compound, solvent (Item 10, WP 0310)

RTV sealant (Item 31, WP 0310)

##### Materials/Parts - Continued

Rag, wiping (Item 26, WP 0310)

Gasket (2)

Locknut (5)

Lockwasher (6)

##### References

WP 0137

##### Equipment Condition

Engine OFF

Left side panel removed (WP 0179)

---

**REMOVAL**

1. At left rear of engine compartment, remove nut (Figure 1, Item 1), lockwasher (Figure 1, Item 2), and terminal of rear wiring harness lead (Figure 1, Item 3) from fuel gage sending unit (Figure 1, Item 12). Discard lockwasher.
2. Remove five capscrews (Figure 1, Item 4), lockwashers (Figure 1, Item 5), one end of ground strap (Figure 1, Item 11), plate (Figure 1, Item 6), gasket (Figure 1, Item 7), and fuel gage sending unit (Figure 1, Item 12) from top of fuel tank. Discard lockwashers and gasket.
3. Remove five screws (Figure 1, Item 8), washers (Figure 1, Item 9), locknuts (Figure 1, Item 10), and other end of ground strap (Figure 1, Item 11). Discard locknuts.
4. Remove fuel gage sending unit (Figure 1, Item 12) and gasket (Figure 1, Item 13) from plate (Figure 1, Item 6). Discard gasket.

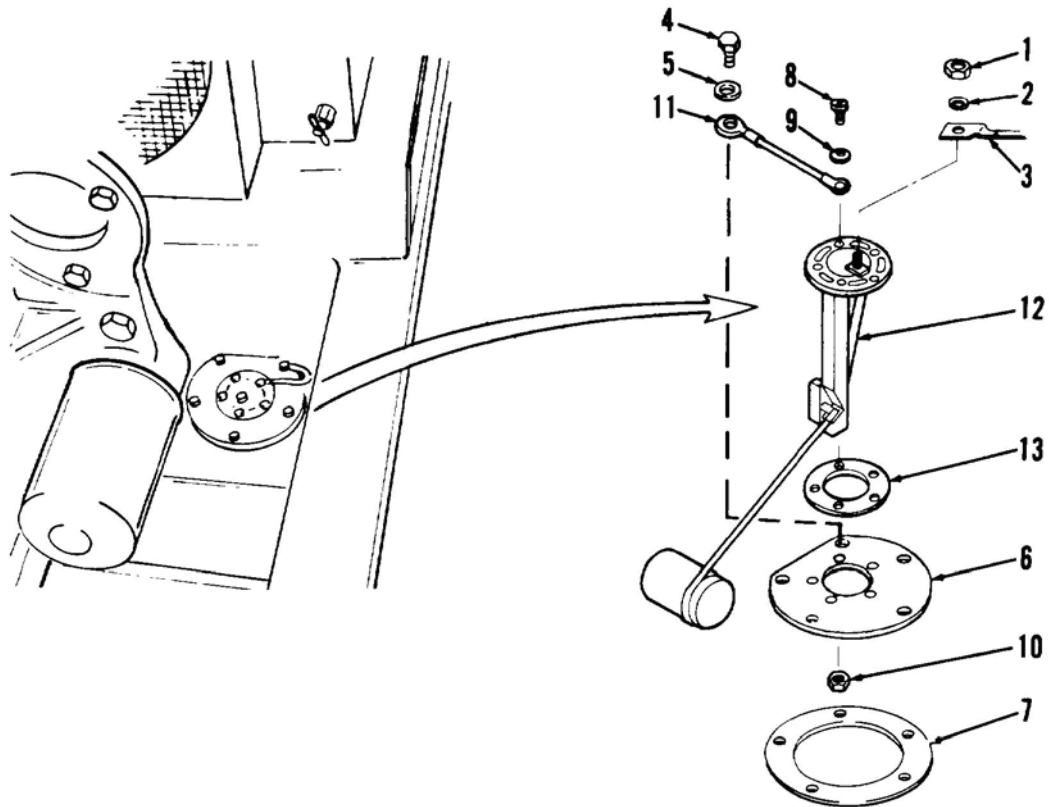

TA126936

**Figure 1. Fuel Gage Sending Unit.****END OF TASK**

**CLEANING****WARNING**

- Solvent cleaning compound MIL-PRF-680 Type III is an environmentally compliant and low toxic material. However, it may be irritating to the eyes and skin. Use protective gloves and goggles. Use in well-ventilated areas. Keep away from open flames and other sources of ignition. Failure to do so may result in injury or death to personnel.
  - Particles blown by compressed air are hazardous. DO NOT exceed 15 PSI (103 kPa) nozzle pressure when drying parts with compressed air. DO NOT direct compressed air against human skin. Make sure air stream is directed away from user and other personnel in the area. To prevent injury, user must wear protective goggles or face shield. Failure to follow this warning may result in injury to personnel. Failure to follow this warning may result in injury to personnel.
1. Clean terminal of rear wiring harness lead with solvent cleaning compound. Dry thoroughly.
  2. Clean terminals of ground strap with solvent cleaning compound. Dry thoroughly.
  3. Clean all other parts with solvent cleaning compound. Dry with compressed air.

**END OF TASK****INSPECTION**

1. Inspect wire lead of rear wiring harness. Repair if insulation is worn, missing, or damaged (WP 0137).
2. Inspect ground strap. Replace if insulation is worn, missing, or damaged. Replace if terminals are damaged or corroded.
3. Inspect all other parts. Replace if damaged or threads are damaged.

**END OF TASK****INSTALLATION****NOTE**

In step 1, make sure terminal at top of sending unit is directly opposite flat on side of plate.

1. Position new gasket (Figure 1, Item 13) and fuel gage sending unit (Figure 1, Item 12) on plate (Figure 1, Item 6).
2. Install one end of ground strap (Figure 1, Item 11), five screws (Figure 1, Item 8), washers (Figure 1, Item 9), and new locknuts (Figure 1, Item 10).
3. At top of fuel tank, install new gasket (Figure 1, Item 7), plate (Figure 1, Item 6), and other end of ground strap (Figure 1, Item 11) with five new lockwashers (Figure 1, Item 5) and capscrews (Figure 1, Item 4).
4. Connect terminal of rear wiring harness lead (Figure 1, Item 3) to fuel gage sending unit (Figure 1, Item 12) and install new lockwasher (Figure 1, Item 2) and nut (Figure 1, Item 1).

**END OF TASK****END OF WORK PACKAGE**



---

## ORGANIZATIONAL MAINTENANCE INSTRUCTIONS

### NEUTRAL START SWITCH AND BACK-UP ALARM SWITCH REPLACEMENT (MODEL 207)

Removal, Cleaning, Inspection, Installation

---

#### INITIAL SETUP

##### Maintenance Level

Organizational

##### Tools and Special Tools

Tool kit, general mechanic's (Item 15, WP 0309)

Shop equipment, common no. 1 (Item 2, WP 0309)

##### Materials/Parts

Cleaning compound, solvent (Item 10, WP 0310)

##### Materials/Parts - Continued

Rag, wiping (Item 26, WP 0310)

Lockwasher (2)

##### References

WP 0137

##### Equipment Condition

Left side panel removed (WP 0179)

---

#### NOTE

Perform the following steps for either the neutral start switch or the back-up alarm switch.

**REMOVAL**

1. At transmission control valve, remove two screws (Figure 1, Item 1), lockwashers (Figure 1, Item 2), and disconnect two wire leads (Figure 1, Item 3) of rear wiring harness from switch (Figure 1, Item 4). Discard lockwashers.
2. Remove switch (Figure 1, Item 4) from transmission control valve.

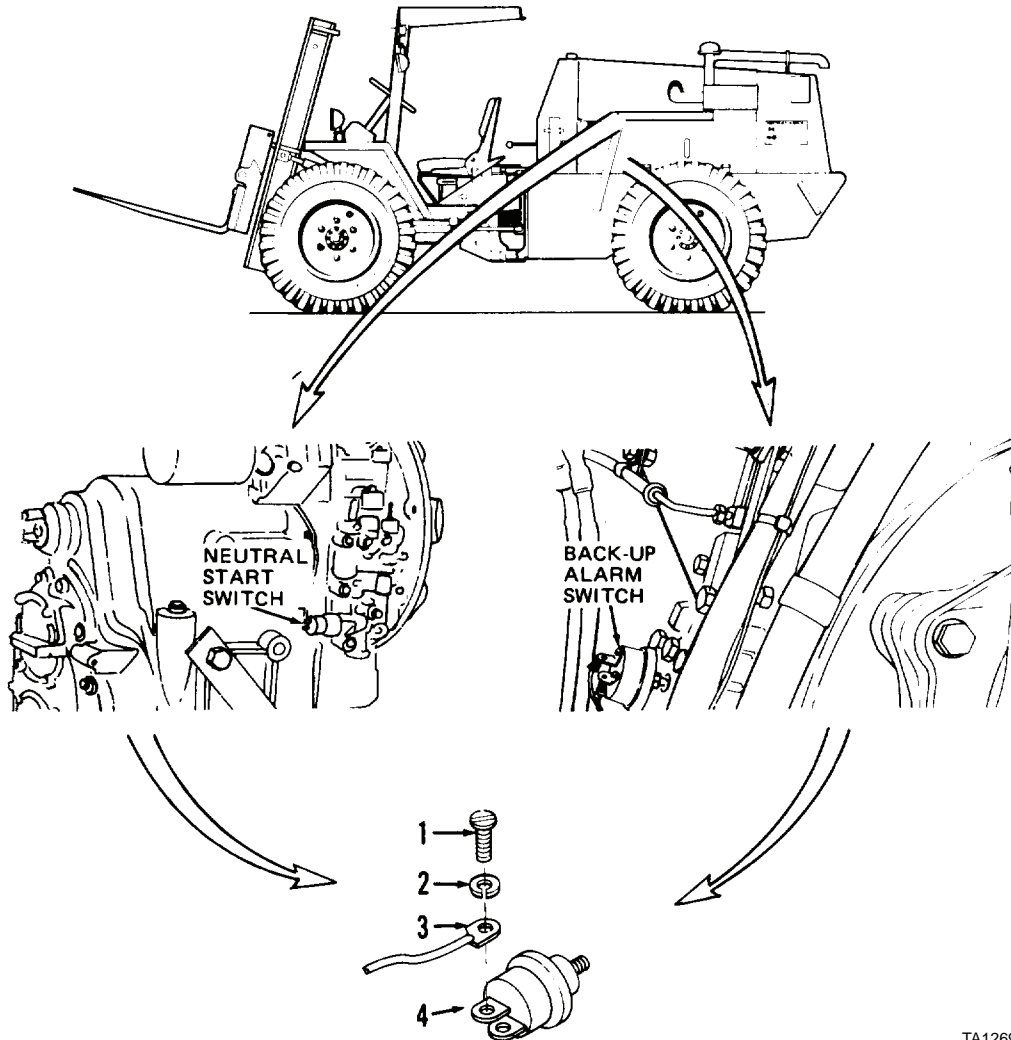

TA126937

**Figure 1. Neutral Start and Back-Up Alarm Switch.****END OF TASK**



**CLEANING****WARNING**

- Solvent cleaning compound MIL-PRF-680 Type III is an environmentally compliant and low toxic material. However, it may be irritating to the eyes and skin. Use protective gloves and goggles. Use in well-ventilated areas. Keep away from open flames and other sources of ignition. Failure to do so may result in injury or death to personnel.
  - Particles blown by compressed air are hazardous. DO NOT exceed 15 PSI (103 kPa) nozzle pressure when drying parts with compressed air. DO NOT direct compressed air against human skin. Make sure air stream is directed away from user and other personnel in the area. To prevent injury, user must wear protective goggles or face shield. Failure to follow this warning may result in injury to personnel.
1. Clean terminals of wire leads with solvent cleaning compound. Dry thoroughly.
  2. Clean screws with solvent cleaning compound. Dry with compressed air.

**END OF TASK****INSPECTION**

1. Inspect wire leads of rear wiring harness. Repair if insulation is worn, missing, or damaged (WP 0137).
2. Inspect screws. Replace if damaged or threads are damaged.

**END OF TASK****INSTALLATION**

1. Install switch (Figure 1, Item 4) on transmission control valve.
2. Connect two leads (Figure 1, Item 3) of rear wiring harness to switch (Figure 1, Item 4) and install two new lockwashers (Figure 1, Item 2) and nuts (Figure 1, Item 1).

**END OF TASK****END OF WORK PACKAGE**



---

## ORGANIZATIONAL MAINTENANCE INSTRUCTIONS

### NEUTRAL START SWITCH AND BACK-UP ALARM SWITCH REPLACEMENT (MODEL 4-390)

Removal, Cleaning, Inspection, Installation

---

#### INITIAL SETUP

##### Maintenance Level

Organizational

##### Tools and Special Tools

Tool kit, general mechanic's (Item 15, WP 0309)

Shop equipment, common no. 1 (Item 2, WP 0309)

##### Materials/Parts

Cleaning compound, solvent (Item 10, WP 0310)

##### Materials/Parts - Continued

Rag, wiping (Item 26, WP 0310)

Lockwasher (2)

##### Equipment Condition

Engine OFF

Ignition switch in OFF position and key removed

Left side panel removed (WP 0179)

---

**REMOVAL****NOTE**

Perform step 1 for neutral start switch.

1. Remove two screws (Figure 1, Item 1), lockwashers (Figure 1, Item 2), purple wire (Figure 1, Item 3), and white wire (Figure 1, Item 4) from rear of neutral start switch (Figure 1, Item 5). Discard lockwashers.
2. Remove neutral start switch (Figure 1, Item 5) and washer (Figure 1, Item 6) from transmission control valve (Figure 1, Item 7).

**NOTE**

Perform step 3 for back-up alarm switch.

3. Disconnect connector (Figure 1, Item 8) of back-up alarm switch (Figure 1, Item 9) from connector (Figure 1, Item 10) of rear wiring harness.
4. Remove back-up alarm switch (Figure 1, Item 9) from adapter (Figure 1, Item 11).
5. Remove adapter (Figure 1, Item 11) from transmission control valve (Figure 1, Item 7).

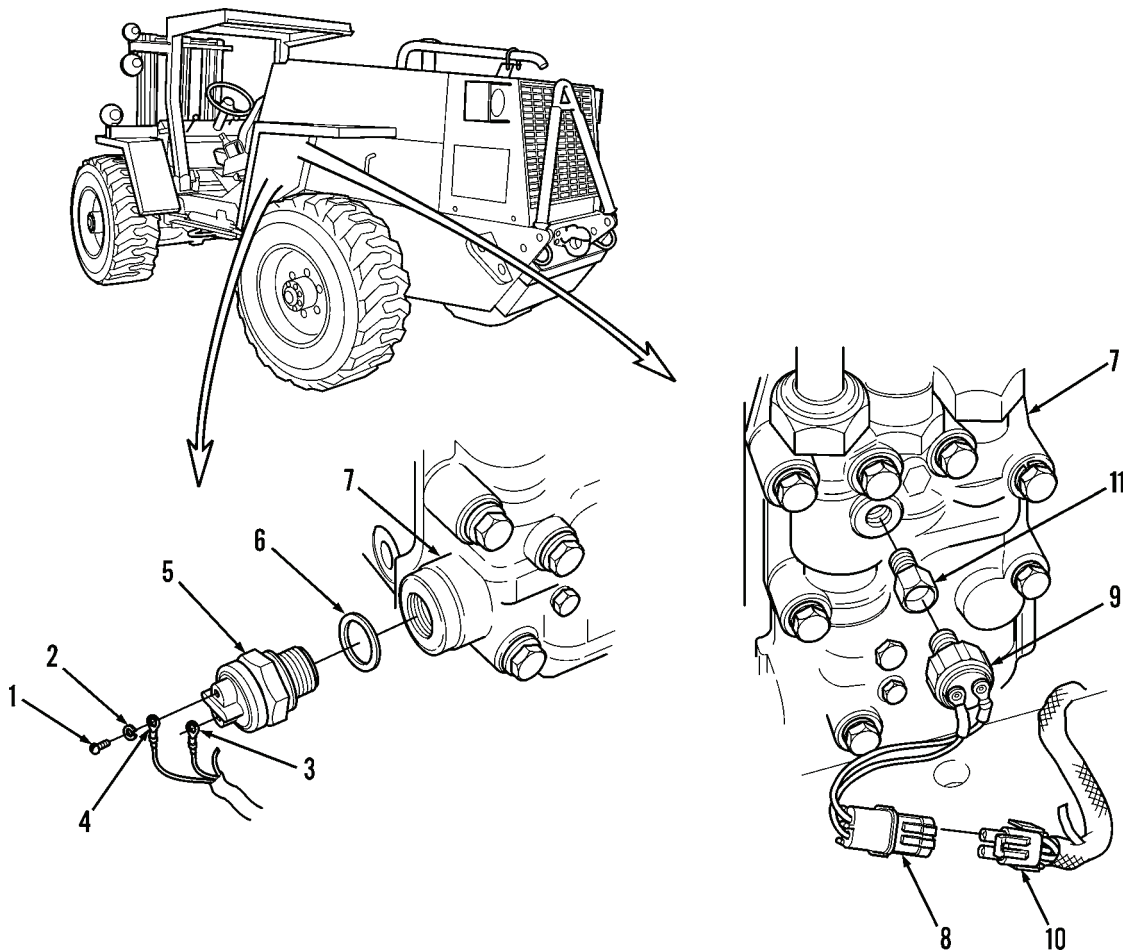

444-0119

**Figure 1. Neutral Start Switch and Back-Up Alarm Switch.**

**END OF TASK**

**CLEANING****WARNING**

- Solvent cleaning compound MIL-PRF-680 Type III is an environmentally compliant and low toxic material. However, it may be irritating to the eyes and skin. Use protective gloves and goggles. Use in well-ventilated areas. Keep away from open flames and other sources of ignition. Failure to do so may result in injury or death to personnel.
  - Particles blown by compressed air are hazardous. DO NOT exceed 15 PSI (103 kPa) nozzle pressure when drying parts with compressed air. DO NOT direct compressed air against human skin. Make sure air stream is directed away from user and other personnel in the area. To prevent injury, user must wear protective goggles or face shield. Failure to follow this warning may result in injury to personnel.
1. Use solvent cleaning compound to clean screws. Dry parts thoroughly with compressed air.
  2. Clean connectors, wire terminals and switch terminals. Use solvent cleaning compound on wire terminals and switch terminals only.

**END OF TASK****INSPECTION**

1. Inspect screws. Replace if worn or if threads damaged.
2. Inspect harness wires. Replace if insulation frayed or if conductors broken.

**END OF TASK****INSTALLATION****NOTE**

Perform step 1 for back-up alarm switch.

1. Install adapter (Figure 1, Item 11) on transmission control valve (Figure 1, Item 7).
2. Install back-up alarm switch (Figure 1, Item 9) on adapter (Figure 1, Item 11).
3. Connect connector (Figure 1, Item 8) of back-up alarm switch (Figure 1, Item 9) to connector (Figure 1, Item 10) of rear wiring harness.

**NOTE**

Perform step 4 for neutral start switch.

4. Install washer (Figure 1, Item 6) and neutral start switch (Figure 1, Item 5) on transmission control valve (Figure 1, Item 7).
5. Install white wire (Figure 1, Item 4), purple wire (Figure 1, Item 3), two new lockwashers (Figure 1, Item 2), and screws (Figure 1, Item 1) on rear of neutral start switch (Figure 1, Item 5).

**END OF TASK****END OF WORK PACKAGE**



---

**ORGANIZATIONAL MAINTENANCE INSTRUCTIONS**  
**ENGINE TEMPERATURE SWITCH MAINTENANCE (MODEL 207)**  
**Removal, Cleaning, Inspection, Testing, Installation**

---

**INITIAL SETUP****Maintenance Level**

Organizational

**Tools and Special Tools**

Tool kit, general mechanic's (Item 15, WP 0309)

Shop equipment, common no. 1 (Item 2, WP 0309)

Container

**Materials/Parts**

Cleaning compound, solvent (Item 10, WP 0310)

**Materials/Parts - Continued**

Rag, wiping (Item 26, WP 0310)

Lockwasher

Water

Wire, nonelectrical

**References**

WP 0137

**Equipment Condition**

Left side panel removed (WP 0179)

**REMOVAL**

1. At left rear of engine, remove nut (Figure 1, Item 1), lockwasher (Figure 1, Item 2), and wire lead (Figure 1, Item 3) of rear wiring harness from engine temperature switch (Figure 1, Item 4). Discard lockwasher.
2. Remove engine temperature switch (Figure 1, Item 4) from engine.
3. At retainer halves (Figure 1, Item 5) of rear wiring harness, push together, turn, and separate. Remove resistor (Figure 1, Item 6).

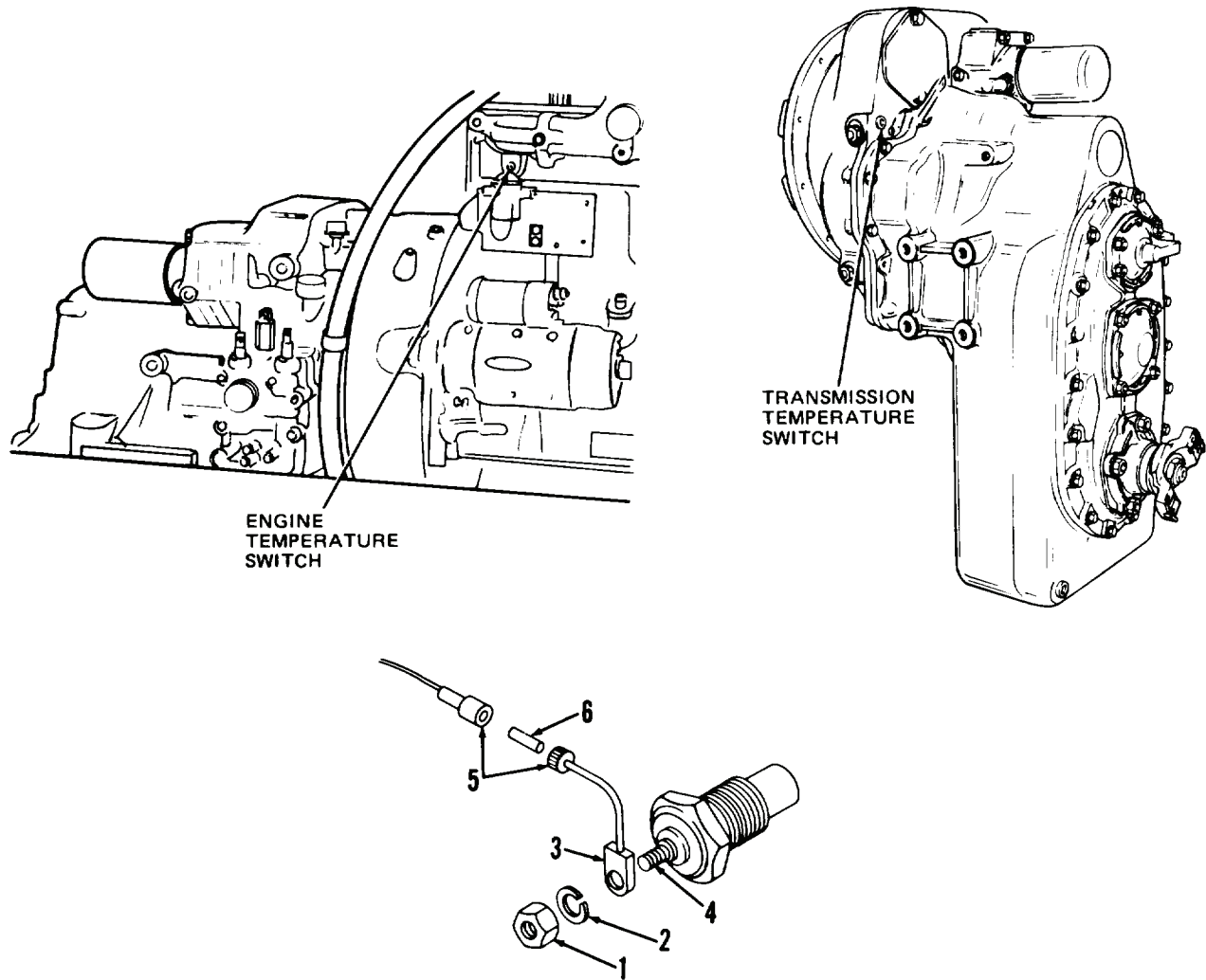

Figure 1. Engine Temperature Switch.

TA126938

**END OF TASK**



**CLEANING****WARNING**

- Solvent cleaning compound MIL-PRF-680 Type III is an environmentally compliant and low toxic material. However, it may be irritating to the eyes and skin. Use protective gloves and goggles. Use in well-ventilated areas. Keep away from open flames and other sources of ignition. Failure to do so may result in injury or death to personnel.
- Particles blown by compressed air are hazardous. DO NOT exceed 15 PSI (103 kPa) nozzle pressure when drying parts with compressed air. DO NOT direct compressed air against human skin. Make sure air stream is directed away from user and other personnel in the area. To prevent injury, user must wear protective goggles or face shield. Failure to follow this warning may result in injury to personnel.

1. Clean parts with solvent cleaning compound. Dry with compressed air.
2. Clean end of wire lead with solvent cleaning compound. Dry thoroughly.

**END OF TASK****INSPECTION**

1. Inspect nut. Replace if threads are damaged.
2. Inspect wire lead of rear wiring harness. Repair if insulation is worn, missing, or damaged (WP 0137).
3. Inspect all other parts. Replace if damaged or threads are damaged.

**END OF TASK****TESTING**

1. Fill small container with water.
2. Connect an ohmmeter between threaded terminal and body of engine temperature switch.
3. Use nonelectrical wire to suspend large threaded portion of engine temperature switch in water.
4. Slowly heat water while observing ohmmeter. Ohmmeter should indicate zero Ohms when temperature of water is 198 to 212°F (92 to 100°C).
5. Replace engine temperature switch if proper indication is not obtained.
6. Remove engine temperature switch from water and disconnect ohmmeter leads and wire.

**END OF TASK****INSTALLATION**

1. At retainer halves (Figure 1, Item 5) of rear wiring harness, install resistor (Figure 1, Item 6) and push halves together, turn, and lock together.
2. Install engine temperature switch (Figure 1, Item 4) on transmission.
3. Install wire lead (Figure 1, Item 3) of rear wiring harness on engine temperature switch (Figure 1, Item 4) with new lockwasher (Figure 1, Item 2) and nut (Figure 1, Item 1).

**END OF TASK****END OF WORK PACKAGE**



---

## ORGANIZATIONAL MAINTENANCE INSTRUCTIONS

### TRANSMISSION TEMPERATURE SWITCH REPLACEMENT (MODEL 207)

Removal, Cleaning, Inspection, Testing, Installation

---

#### INITIAL SETUP

**Maintenance Level**

Organizational

**Tools and Special Tools**

Tool kit, general mechanic's (Item 15, WP 0309)

Shop equipment, common no. 1 (Item 2, WP 0309)

Container

**Materials/Parts**

Cleaning compound, solvent (Item 10, WP 0310)

**Materials/Parts - Continued**

Rag, wiping (Item 26, WP 0310)

Lockwasher

Wire, nonelectrical

**References**

WP 0137

**Equipment Condition**

Right side panel removed (WP 0179)

---

**REMOVAL**

1. At right front of transmission, remove nut (Figure 1, Item 1), lockwasher (Figure 1, Item 2), and wire lead (Figure 1, Item 3) of rear wiring harness from transmission temperature switch ((Figure 1, Item 4). Discard lockwasher.
2. Remove transmission temperature switch (Figure 1, Item 4) from transmission.
3. At retainer halves (Figure 1, Item 5) of rear wiring harness, push together, turn, and separate. Remove resistor (Figure 1, Item 6).

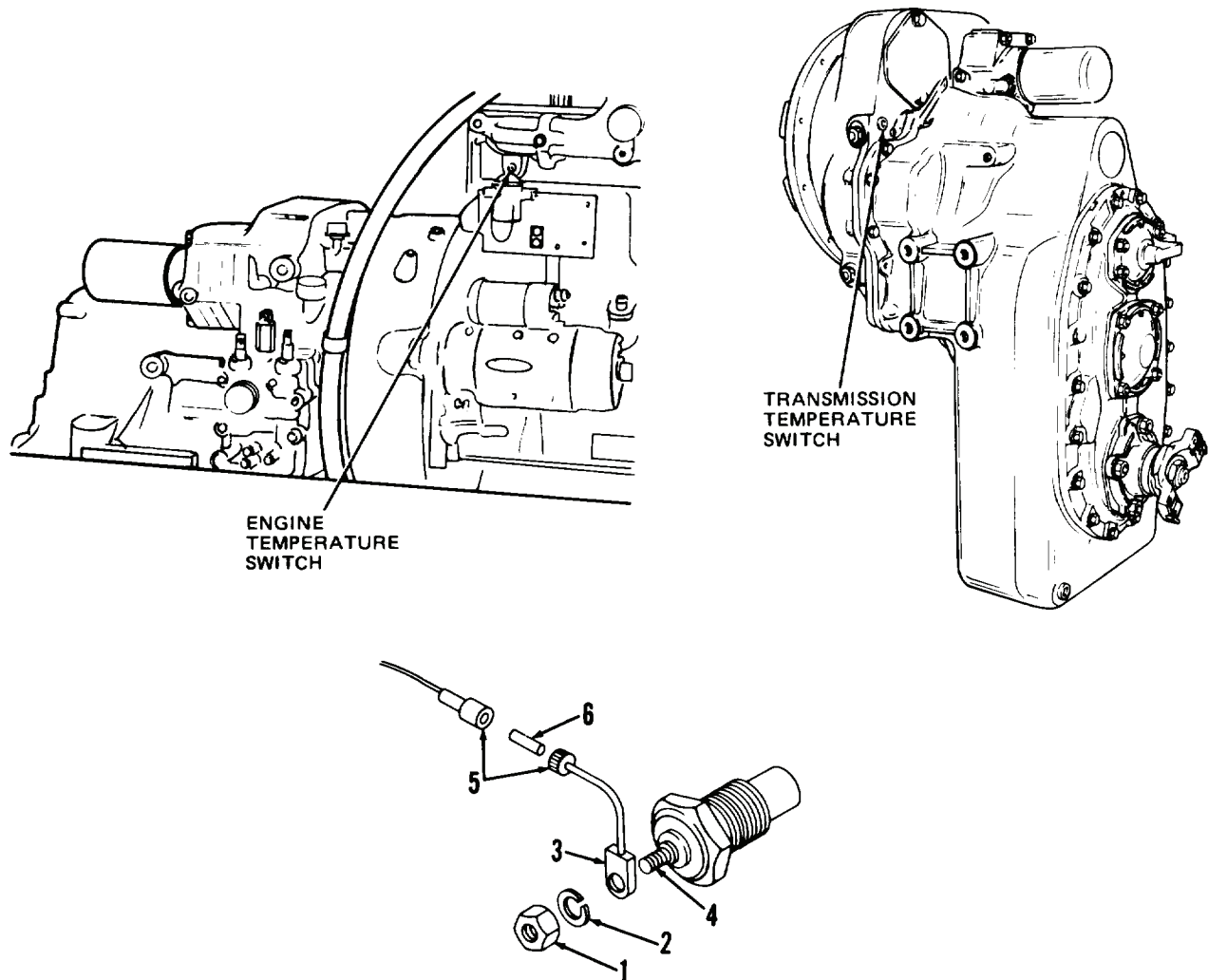

TA126938

**Figure 1. Transmission Temperature Switch.****END OF TASK**

**CLEANING****WARNING**

- Solvent cleaning compound MIL-PRF-680 Type III is an environmentally compliant and low toxic material. However, it may be irritating to the eyes and skin. Use protective gloves and goggles. Use in well-ventilated areas. Keep away from open flames and other sources of ignition. Failure to do so may result in injury or death to personnel.
  - Particles blown by compressed air are hazardous. DO NOT exceed 15 PSI (103 kPa) nozzle pressure when drying parts with compressed air. DO NOT direct compressed air against human skin. Make sure air stream is directed away from user and other personnel in the area. To prevent injury, user must wear protective goggles or face shield. Failure to follow this warning may result in injury to personnel.
1. Clean parts with solvent cleaning compound. Dry with compressed air.
  2. Clean end of wire lead with solvent cleaning compound. Dry thoroughly.

**END OF TASK****INSPECTION**

1. Inspect nut. Replace if threads are damaged.
2. Inspect wire lead of rear wiring harness. Repair if insulation is worn, missing, or damaged (WP 0137).
3. Inspect all other parts. Replace if damaged or threads are damaged.

**END OF TASK****TESTING**

1. Fill small container with oil.
2. Connect an ohmmeter between threaded terminal and body of transmission temperature switch.
3. Use nonelectrical wire to suspend large threaded portion of transmission temperature switch in oil.
4. Slowly heat oil to 280°F (138°C) while observing ohmmeter. Ohmmeter should indicate zero Ohms when temperature of oil is 272 to 285°F (133 to 141°C).
5. Replace transmission temperature switch if proper indication is not obtained.
6. Remove transmission temperature switch from oil and disconnect ohmmeter leads and wire.

**END OF TASK**

**INSTALLATION**

1. At retainer halves (Figure 2, Item 5) of rear wiring harness, install resistor (Figure 2, Item 6) and push halves together, turn, and lock together.
2. Install transmission temperature switch (Figure 2, Item 4) on transmission.
3. Install wire lead (Figure 2, Item 3) of rear wiring harness on transmission temperature switch (Figure 2, Item 4) with new lockwasher (Figure 2, Item 2) and nut (Figure 2, Item 1).

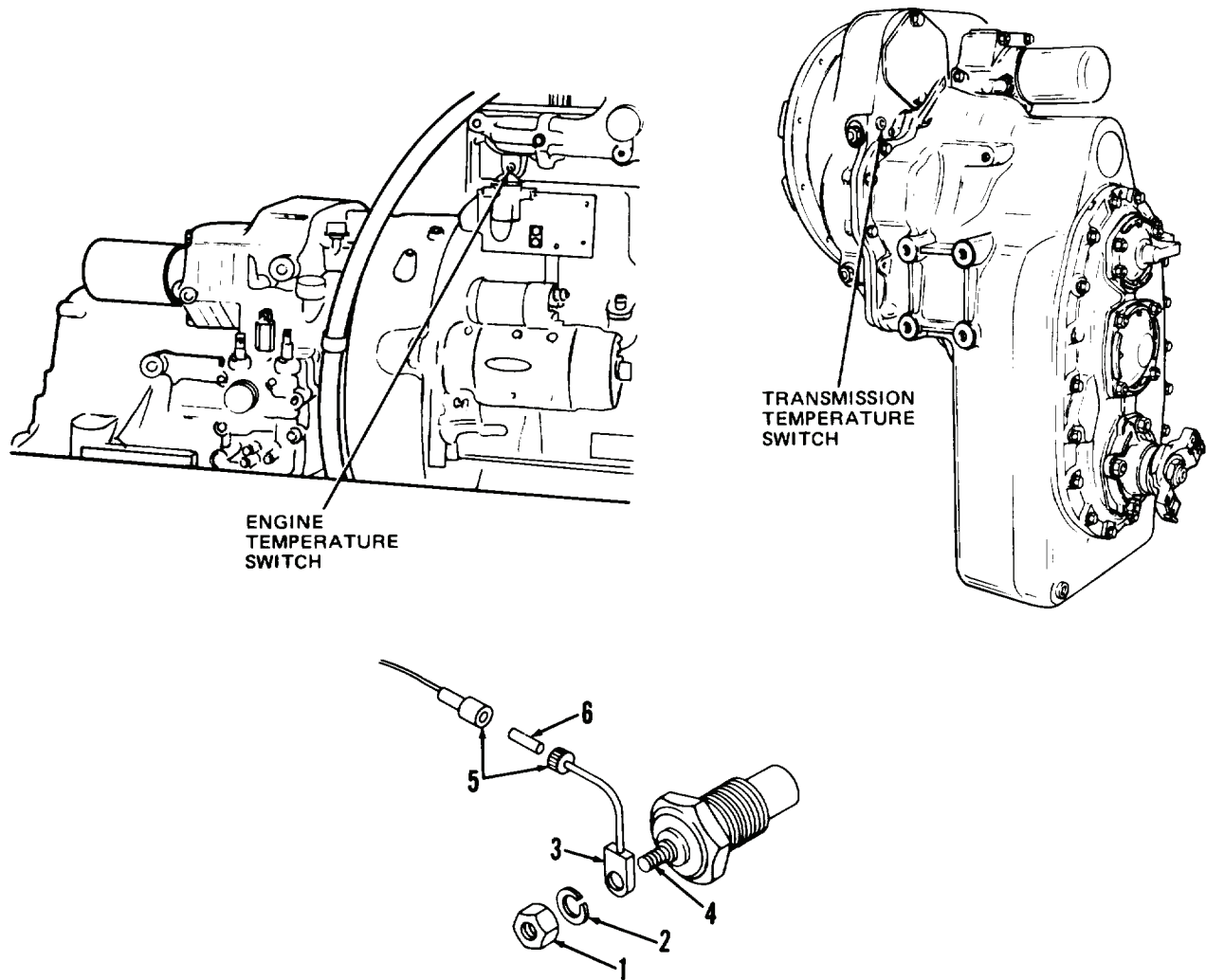

TA126938

**Figure 2. Transmission Temperature Switch.****END OF TASK****END OF WORK PACKAGE**

---

## ORGANIZATIONAL MAINTENANCE INSTRUCTIONS

### ENGINE AND TRANSMISSION TEMPERATURE SWITCHES MAINTENANCE (MODEL 4-390)

Removal, Cleaning, Inspection, Testing, Installation/Replacement

---

#### INITIAL SETUP

##### Maintenance Level

Organizational

##### Tools and Special Tools

Tool kit, general mechanic's (Item 15, WP 0309)  
Shop equipment, common no. 1 (Item 2, WP 0309)  
Container  
Heat source  
String  
Thermometer

##### Materials/Parts

Cleaning compound, solvent (Item 10, WP 0310)  
Lubricating oil, OE/HDO-15/40 (Item 21, WP 0310)  
Rag, wiping (Item 26, WP 0310)  
Lockwasher (2)  
Water

##### Equipment Condition

Engine OFF  
Right side panel removed (WP 0179)

---

**REMOVAL****NOTE**

Perform step 1 for engine temperature switch.

1. Remove nut (Figure 1, Item 1), lockwasher (Figure 1, Item 2), wire (Figure 1, Item 3), and washer (Figure 1, Item 4) from engine temperature switch (Figure 1, Item 5). Discard lockwasher.
2. Remove engine temperature switch (Figure 1, Item 5) and washer (Figure 1, Item 6) from engine.
3. Push retainer halves (Figure 1, Item 7) together, turn, and separate to remove resistor (Figure 1, Item 8).

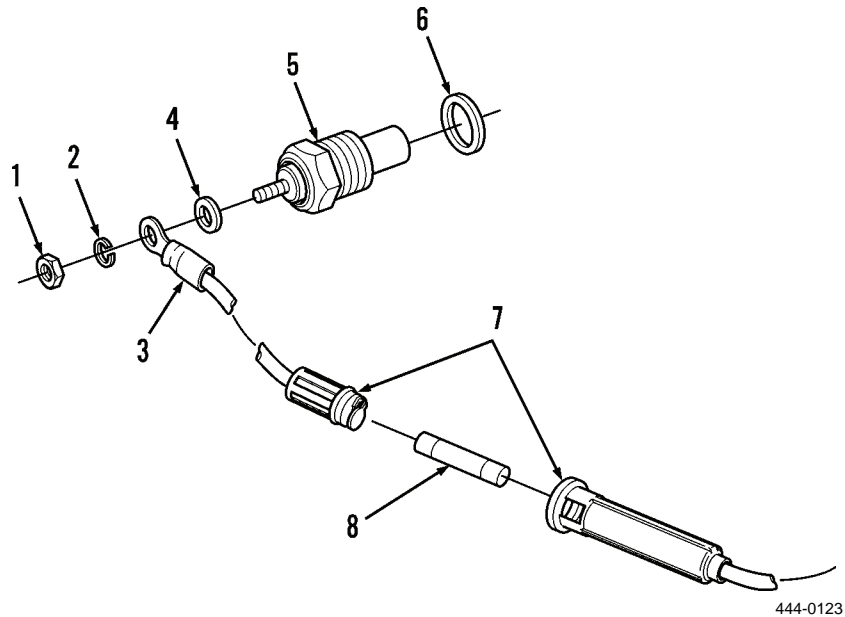

**Figure 1. Engine Temperature Switch.**



**REMOVAL - CONTINUED****NOTE**

Perform step 4 for transmission temperature switch.

4. Remove nut (Figure 2, Item 9), lockwasher (Figure 2, Item 10), and wire (Figure 2, Item 11) from transmission temperature switch (Figure 2, Item 12).
5. Remove transmission temperature switch (Figure 2, Item 12) from transmission.
6. Push retainer halves (Figure 2, Item 13) together, turn, and separate to remove resistor (Figure 2, Item 14).

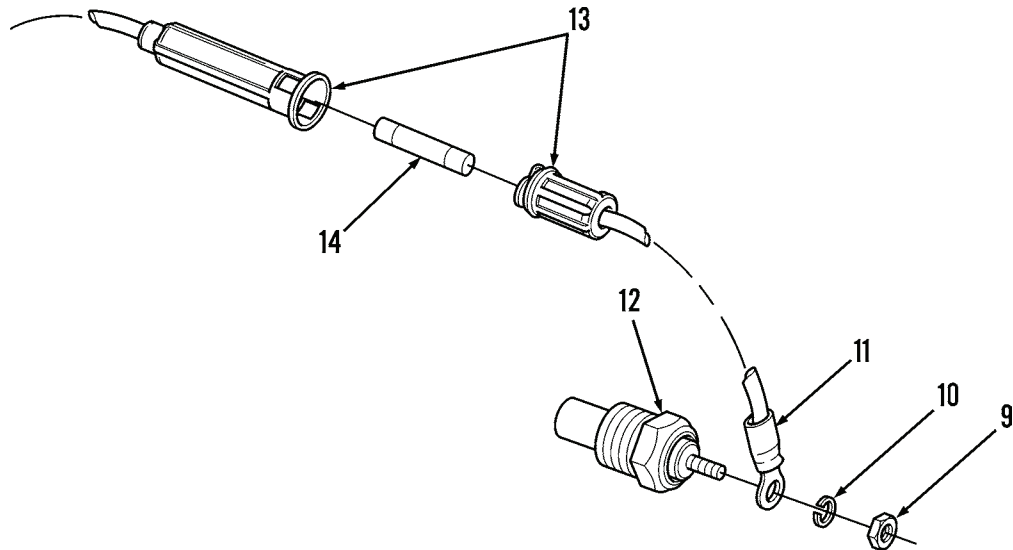

444-0124

**Figure 2. Transmission Temperature Switch.**

**END OF TASK****CLEANING****WARNING**

- Solvent cleaning compound MIL-PRF-680 Type III is an environmentally compliant and low toxic material. However, it may be irritating to the eyes and skin. Use protective gloves and goggles. Use in well-ventilated areas. Keep away from open flames and other sources of ignition. Failure to do so may result in injury or death to personnel.
- Particles blown by compressed air are hazardous. **DO NOT** exceed 15 PSI (103 kPa) nozzle pressure when drying parts with compressed air. **DO NOT** direct compressed air against human skin. Make sure air stream is directed away from user and other personnel in the area. To prevent injury, user must wear protective goggles or face shield. Failure to follow this warning may result in injury to personnel.

1. Clean nuts. Use solvent cleaning compound. Dry thoroughly with compressed air.
2. Clean connectors, wire terminals, and switch terminals. Use solvent cleaning compound on wire terminals and switch terminals only.

---

**END OF TASK****INSPECTION**

1. Inspect nuts. Replace if worn or if threads damaged.
2. Inspect harness wires. Replace if insulation frayed or if conductors broken.

**END OF TASK****TESTING**

1. Engine Temperature Switch.
  - a. Fill container with water.
  - b. Suspend threaded portion of engine temperature switch in water.
  - c. Connect ohmmeter between terminal and body of engine temperature switch.
  - d. Ohmmeter should indicate infinity.
  - e. Slowly heat water while observing ohmmeter.
  - f. Ohmmeter should indicate zero Ohms when temperature of water is 198 to 212°F (92 to 100°C).
  - g. Replace engine temperature switch if proper indication is not obtained.
  - h. Remove engine temperature switch from water and disconnect ohmmeter leads.
2. Transmission Temperature Switch.
  - a. Fill container with oil.
  - b. Suspend threaded portion of transmission temperature switch in oil.
  - c. Connect ohmmeter between transmission temperature switch terminal and body.
  - d. Ohmmeter should indicate infinity.
  - e. Slowly heat oil to 280°F (138°C) while observing ohmmeter.
  - f. Ohmmeter should indicate zero Ohms when temperature of oil is 285 to 272°F (141 to 133°C).
  - g. Replace transmission temperature switch if proper indication is not obtained.
  - h. Remove transmission temperature switch from oil and disconnect ohmmeter leads.

**END OF TASK**

**INSTALLATION/REPLACEMENT****NOTE**

Perform step 1 for transmission temperature switch.

1. Position resistor (Figure 3, Item 14) in retainer halves (Figure 3, Item 13).
2. Push retainer halves (Figure 3, Item 13) together and turn to secure resistor (Figure 3, Item 14).
3. Install transmission temperature switch (Figure 3, Item 12) on transmission.
4. Install wire (Figure 3, Item 11), washer (Figure 3, Item 10), and nut (Figure 3, Item 9) on transmission temperature switch (Figure 3, Item 12).

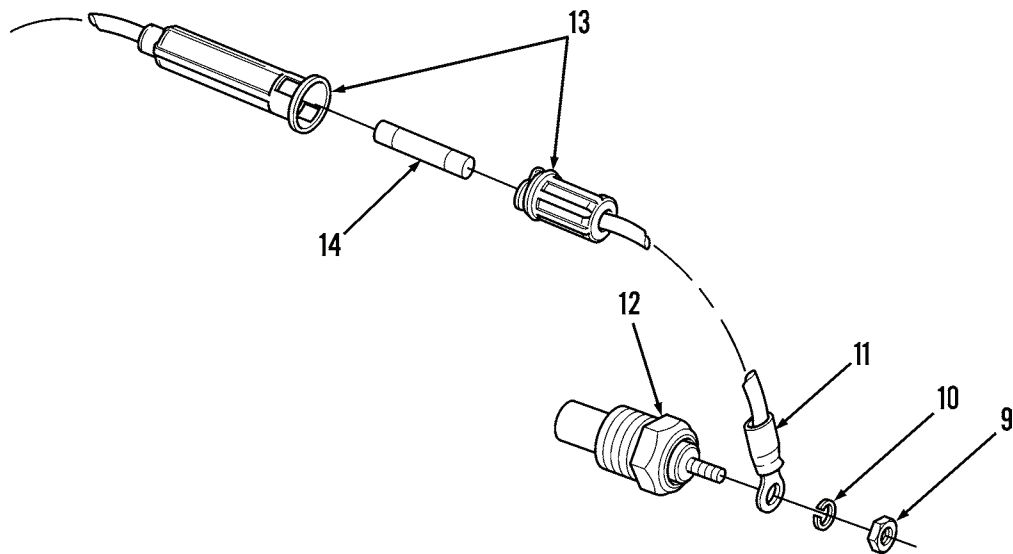

444-0124

**Figure 3. Transmission Temperature Switch.**

**INSTALLATION/REPLACEMENT - CONTINUED****NOTE**

Perform step 5 for engine temperature switch.

5. Position resistor (Figure 4, Item 8) in retainer halves (Figure 4, Item 7).
6. Push retainer halves (Figure 4, Item 7) together and turn to secure resistor (Figure 4, Item 8).
7. Install washer (Figure 4, Item 6) and engine temperature switch (Figure 4, Item 5) on engine.
8. Install washer (Figure 4, Item 4), wire (Figure 4, Item 3), new lockwasher (Figure 4, Item 2), and nut (Figure 4, Item 1) on engine temperature switch (Figure 4, Item 5).

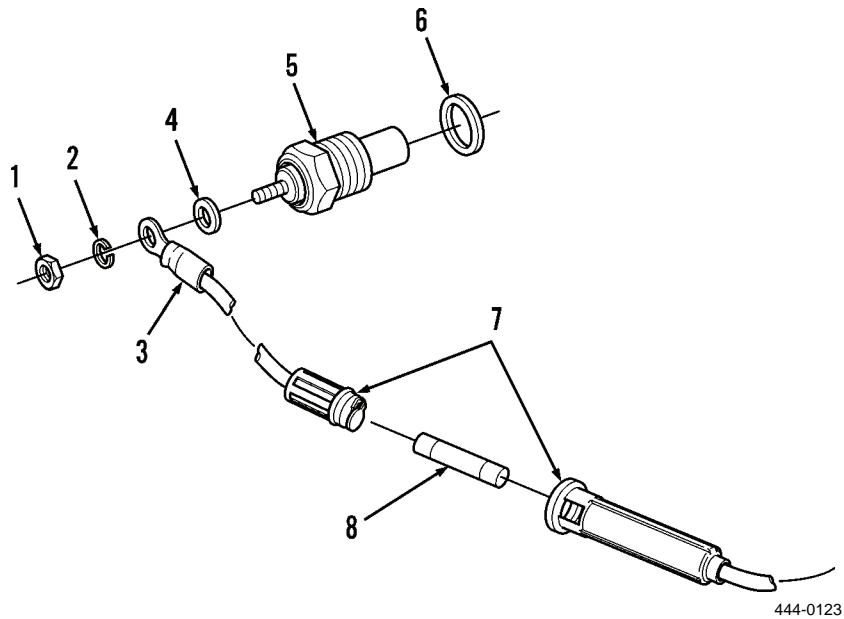

**Figure 4. Engine Temperature Switch.**

**END OF TASK**

**END OF WORK PACKAGE**

---

## ORGANIZATIONAL MAINTENANCE INSTRUCTIONS

### ENGINE OIL PRESSURE SWITCH AND SENDING UNIT MAINTENANCE (MODEL 207)

Removal, Cleaning, Inspection, Installation/Replacement, Testing Oil Pressure Sender

---

#### INITIAL SETUP

##### Maintenance Level

Organizational

##### Tools and Special Tools

Tool kit, general mechanic's (Item 15, WP 0309)

Shop equipment, common no. 1 (Item 2, WP 0309)

##### Materials/Parts

Cleaning compound, solvent (Item 10, WP 0310)

##### Materials/Parts - Continued

Rag, wiping (Item 26, WP 0310)

RTV sealant (Item 31, WP 0310)

Lockwasher (2)

##### Equipment Condition

Engine OFF

Ignition switch in OFF position and key removed

Right side panel removed (WP 0179)

---

**REMOVAL**

1. Disconnect harness connector (Figure 1, Item 1) from terminal on oil pressure switch (Figure 1, Item 6).
2. Remove nut (Figure 1, Item 2), lockwasher (Figure 1, Item 3), and wire lead (Figure 1, Item 4) from terminal on oil pressure sender (Figure 1, Item 5). Discard lockwasher.
3. Remove oil pressure sender (Figure 1, Item 5) and oil pressure switch (Figure 1, Item 6) from tee (Figure 1, Item 7).
4. Remove tee (Figure 1, Item 7) and fitting (Figure 1, Item 8) from engine block.
5. Disconnect retainer halves (Figure 1, Item 9) and remove resistor (Figure 1, Item 10).

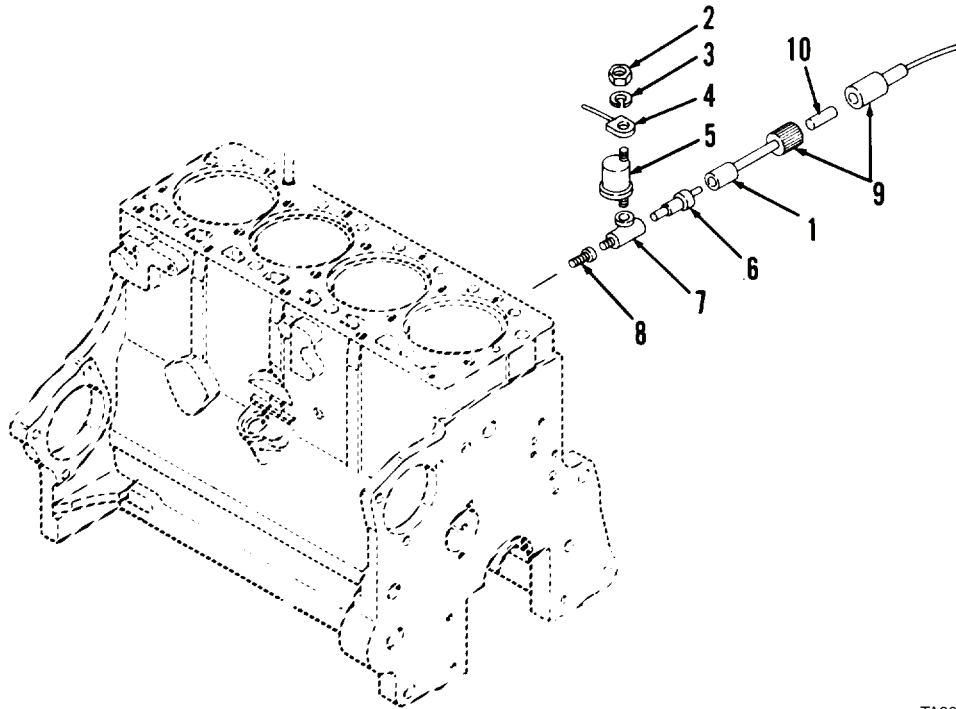

TA301522

**Figure 1. Engine Oil Pressure Switch and Sending Unit.****END OF TASK**

**CLEANING****WARNING**

- Solvent cleaning compound MIL-PRF-680 Type III is an environmentally compliant and low toxic material. However, it may be irritating to the eyes and skin. Use protective gloves and goggles. Use in well-ventilated areas. Keep away from open flames and other sources of ignition. Failure to do so may result in injury or death to personnel.
  - Particles blown by compressed air are hazardous. DO NOT exceed 15 PSI (103 kPa) nozzle pressure when drying parts with compressed air. DO NOT direct compressed air against human skin. Make sure air stream is directed away from user and other personnel in the area. To prevent injury, user must wear protective goggles or face shield. Failure to follow this warning may result in injury to personnel.
1. Use solvent cleaning compound to clean nut (Figure 1, Item 2), tee (Figure 1, Item 7), and fitting (Figure 1, Item 8). Dry thoroughly with compressed air.
  2. Clean wire connectors and switch terminals. Use solvent cleaning compound on connectors and terminals only.

**END OF TASK****INSPECTION**

1. Inspect nut (Figure 1, Item 2), tee (Figure 1, Item 7), and fitting (Figure 1, Item 8). Replace if worn or cracked, or if threads damaged.
2. Inspect harness wires. Replace if insulation frayed, or if conductor broken.

**END OF TASK****INSTALLATION/REPLACEMENT**

1. Install fitting (Figure 1, Item 8) and tee (Figure 1, Item 7) and tighten tee until securely mounted on engine block.
2. Install oil pressure sender (Figure 1, Item 5) and oil pressure switch (Figure 1, Item 6) and tighten oil pressure sender and oil pressure switch until securely mounted to tee (Figure 1, Item 7).
3. Install wire lead (Figure 1, Item 4), new lockwasher (Figure 1, Item 3), and nut (Figure 1, Item 2) and tighten nut until wire lead (Figure 1, Item 4) is securely mounted to terminal of oil pressure sender (Figure 1, Item 5).
4. Connect harness connector (Figure 1, Item 1) to terminal of oil pressure switch (Figure 1, Item 6).
5. Use silicone rubber sealer to seal wire leads (Figure 1, Items 1 and 4) and terminals.
6. Position resistor (Figure 1, Item 10) in retainer halves (Figure 1, Item 9).
7. Connect retainer halves (Figure 1, Item 9) to secure resistor (Figure 1, Item 10).

**END OF TASK**

**TESTING OIL PRESSURE SENDER**

1. Remove nut (Figure 2, Item 2) and lockwasher (Figure 2, Item 3) from oil pressure sender (Figure 2, Item 5).
2. Disconnect wire lead (Figure 2, Item 4) from oil pressure sender (Figure 2, Item 5).
3. Between oil pressure sender terminal and engine block, set ohmmeter to X1 scale. Ohmmeter should indicate 1 Ohm or less.
4. Place ignition switch in ON position.
5. Start and operate engine.
6. With engine idling, resistance should be over 13.5 Ohms; increase engine speed. Resistance indicated on ohmmeter should increase.
7. If ohmmeter indicates more than 1 Ohm in step 3, or if resistance is not over 13.5 Ohms or does not increase when engine speed increases in step 6, replace oil pressure sender.
8. Place ignition switch in OFF position.
9. Connect wire lead (Figure 2, Item 4) to oil pressure sender terminal (Figure 2, Item 5).
10. Install lockwasher (Figure 2, Item 3) and nut (Figure 2, Item 2) on oil pressure sender (Figure 2, Item 5) and tighten nut.

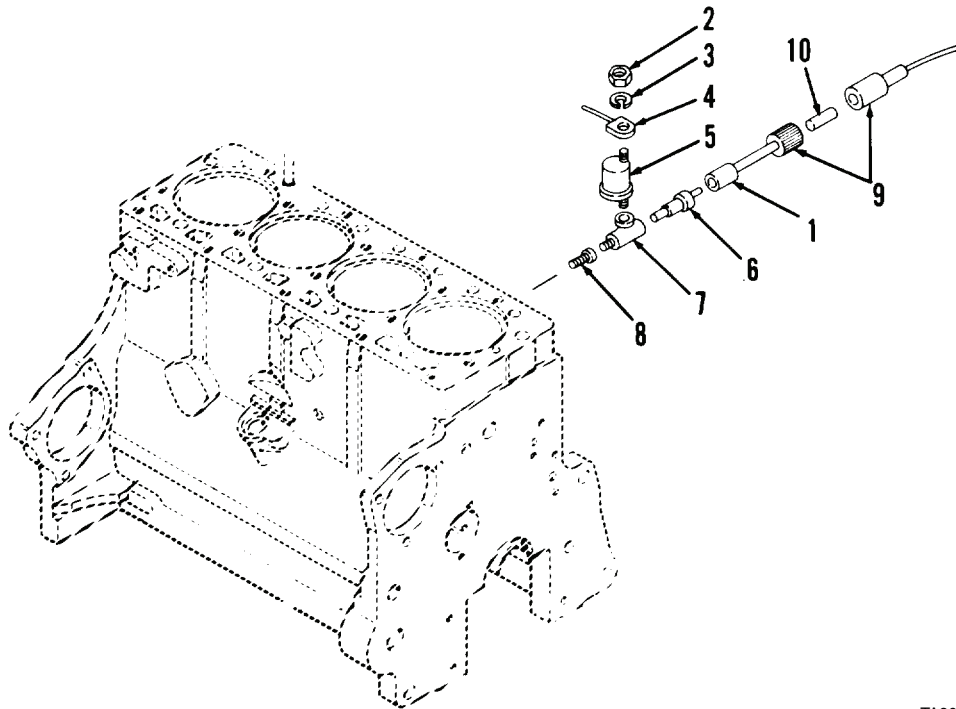

TA301522

**Figure 2. Engine Oil Pressure Switch and Sending Unit.****END OF TASK****END OF WORK PACKAGE**



---

## ORGANIZATIONAL MAINTENANCE INSTRUCTIONS

### ENGINE OIL PRESSURE SWITCH AND SENDING UNIT MAINTENANCE (MODEL 4-390)

Removal, Cleaning, Inspection, Installation/Replacement, Testing Oil Pressure Sender

---

#### INITIAL SETUP

##### Maintenance Level

Organizational

##### Tools and Special Tools

Tool kit, general mechanic's (Item 15, WP 0309)

Shop equipment, common no. 1 (Item 2, WP 0309)

##### Materials/Parts

Cleaning compound, solvent (Item 10, WP 0310)

Rag, wiping (Item 26, WP 0310)

Lockwasher

##### Equipment Condition

Engine OFF

Right side panel removed (WP 0179)

---

**REMOVAL**

1. Remove nut (Figure 1, Item 1), lockwasher (Figure 1, Item 2), wire (Figure 1, Item 3), and washer (Figure 1, Item 4) from oil pressure sender (Figure 1, Item 5). Discard lockwasher.
2. Remove oil pressure sender (Figure 1, Item 5) from tee (Figure 1, Item 6).
3. Disconnect wire (Figure 1, Item 7) from terminal of oil pressure switch (Figure 1, Item 8).
4. Push retainer halves (Figure 1, Item 9) together, turn, and separate to remove resistor (Figure 1, Item 10).
5. Remove oil pressure switch (Figure 1, Item 8) from tee (Figure 1, Item 6).
6. Remove tee (Figure 1, Item 6) and fitting (Figure 1, Item 11) from side of engine.

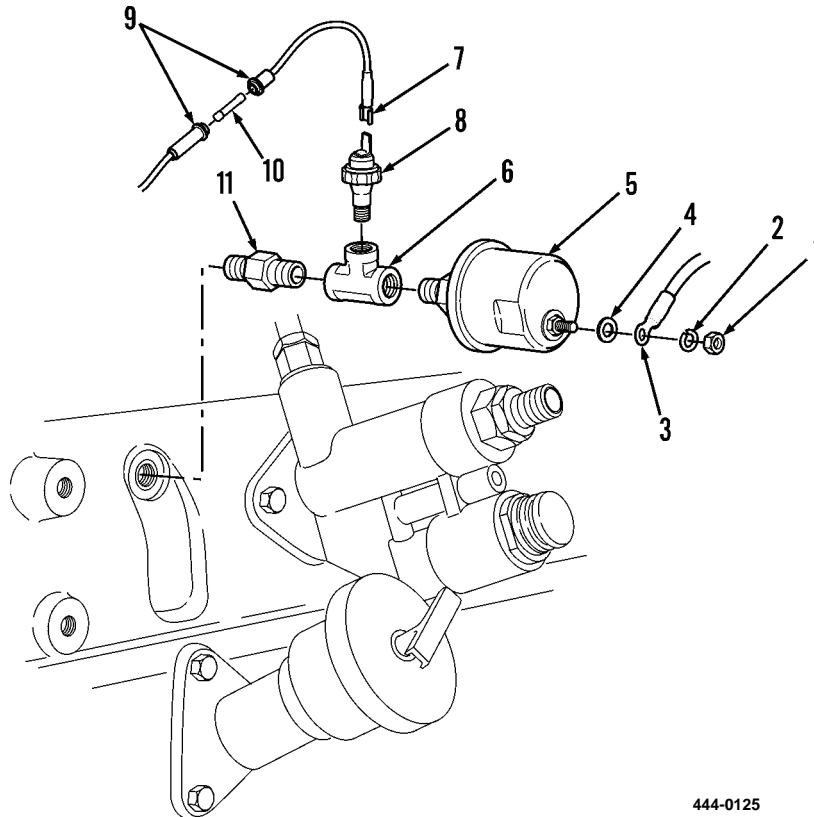

444-0125

**Figure 1. Engine Oil Pressure Switch and Sending Unit.****END OF TASK**

**CLEANING****WARNING**

- Solvent cleaning compound MIL-PRF-680 Type III is an environmentally compliant and low toxic material. However, it may be irritating to the eyes and skin. Use protective gloves and goggles. Use in well-ventilated areas. Keep away from open flames and other sources of ignition. Failure to do so may result in injury or death to personnel.
  - Particles blown by compressed air are hazardous. DO NOT exceed 15 PSI (103 kPa) nozzle pressure when drying parts with compressed air. DO NOT direct compressed air against human skin. Make sure air stream is directed away from user and other personnel in the area. To prevent injury, user must wear protective goggles or face shield. Failure to follow this warning may result in injury to personnel.
1. Clean nut (Figure 1, Item 1), washer (Figure 1, Item 4), tee (Figure 1, Item 6), and fitting (Figure 1, Item 11). Use solvent cleaning compound. Dry thoroughly with compressed air.
  2. Clean wire connector, switch terminal, wire terminal, and sender terminal. Use solvent cleaning compound on connector and terminals only.

**END OF TASK****INSPECTION**

1. Inspect nut (Figure 1, Item 1), washer (Figure 1, Item 4), tee (Figure 1, Item 6), and fitting (Figure 1, Item 11). Replace if worn, or if threads damaged.
2. Inspect harness wires (Figure 1, Items 3 and 7). Replace if insulation frayed, or if conductor broken.

**END OF TASK****INSTALLATION/REPLACEMENT**

1. Install fitting (Figure 1, Item 11) and tee (Figure 1, Item 6) on side of engine.
2. Install oil pressure switch (Figure 1, Item 8) on tee (Figure 1, Item 6).
3. Position resistor (Figure 1, Item 10) in retainer halves (Figure 1, Item 9).
4. Push retainer halves (Figure 1, Item 9) together, turn, and release to secure resistor (Figure 1, Item 10).
5. Push wire (Figure 1, Item 7) on terminal of oil pressure switch (Figure 1, Item 8).
6. Install oil pressure sender (Figure 1, Item 5) on tee (Figure 1, Item 6).
7. Install washer (Figure 1, Item 4), wire (Figure 1, Item 3), new lockwasher (Figure 1, Item 2), and nut (Figure 1, Item 1) on oil pressure sender (Figure 1, Item 5).

**END OF TASK**

**TESTING OIL PRESSURE SENDER**

1. Remove nut (Figure 2, Item 1), lockwasher (Figure 2, Item 2), wire (Figure 2, Item 3), and washer (Figure 2, Item 4) from oil pressure sender (Figure 2, Item 5).
2. Connect ohmmeter positive test lead to oil pressure sender (Figure 2, Item 5) terminal and negative test lead to engine block. Set ohmmeter to X1 scale. Ohmmeter should indicate 1 Ohm or less.
3. Place ignition switch in ON position start and operate engine.
4. Observe ohmmeter with engine idling; resistance should be over 13.5 Ohms; increase engine speed. Resistance indicated on ohmmeter should increase.
5. If ohmmeter indicates more than 1 Ohm in step 2, or if resistance is not over 13.5 Ohms or does not increase when engine speed increases in step 4, replace oil pressure sender.
6. Place ignition switch in OFF position.
7. Disconnect ohmmeter from oil pressure sender (Figure 2, Item 5) terminal and engine block.
8. Install washer (Figure 2, Item 4), wire (Figure 2, Item 3), new lockwasher (Figure 2, Item 2), and nut (Figure 2, Item 1) on oil pressure sender (Figure 2, Item 5).

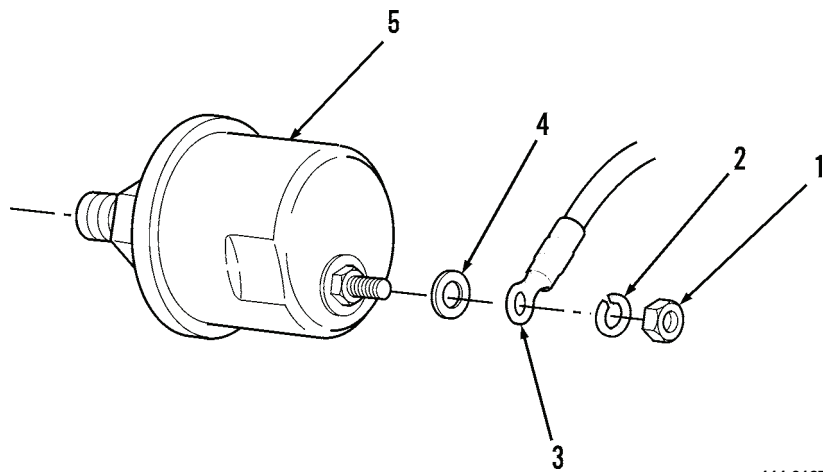

444-0127

**Figure 2. Oil Pressure Sender and Associated Parts.****END OF TASK****END OF WORK PACKAGE**

---

## ORGANIZATIONAL MAINTENANCE INSTRUCTIONS

### HYDRAULIC FILTER RESTRICTION SWITCH REPLACEMENT

Removal, Cleaning, Inspection, Installation

---

#### INITIAL SETUP

**Maintenance Level**

Organizational

**Tools and Special Tools**

Tool kit, general mechanic's (Item 15, WP 0309)

Shop equipment, common no. 1 (Item 2, WP 0309)

**Materials/Parts**

Cleaning compound, solvent (Item 10, WP 0310)

**Materials/Parts - Continued**

Rag, wiping (Item 26, WP 0310)

RTV sealant (Item 31, WP 0310)

**Equipment Condition**

Engine OFF

Ignition switch in OFF position and key removed

Left side panel removed (engine temperature switch) (WP 0179)

Chassis guard removed (WP 0188)

---

**REMOVAL**

1. Remove screw (Figure 1, Item 1) and wire lead (Figure 1, Item 2) from terminal on switch (Figure 1, Item 3).
2. Remove switch (Figure 1, Item 3) from hydraulic filter.
3. Disconnect retainer halves (Figure 1, Item 4) and remove resistor (Figure 1, Item 5).

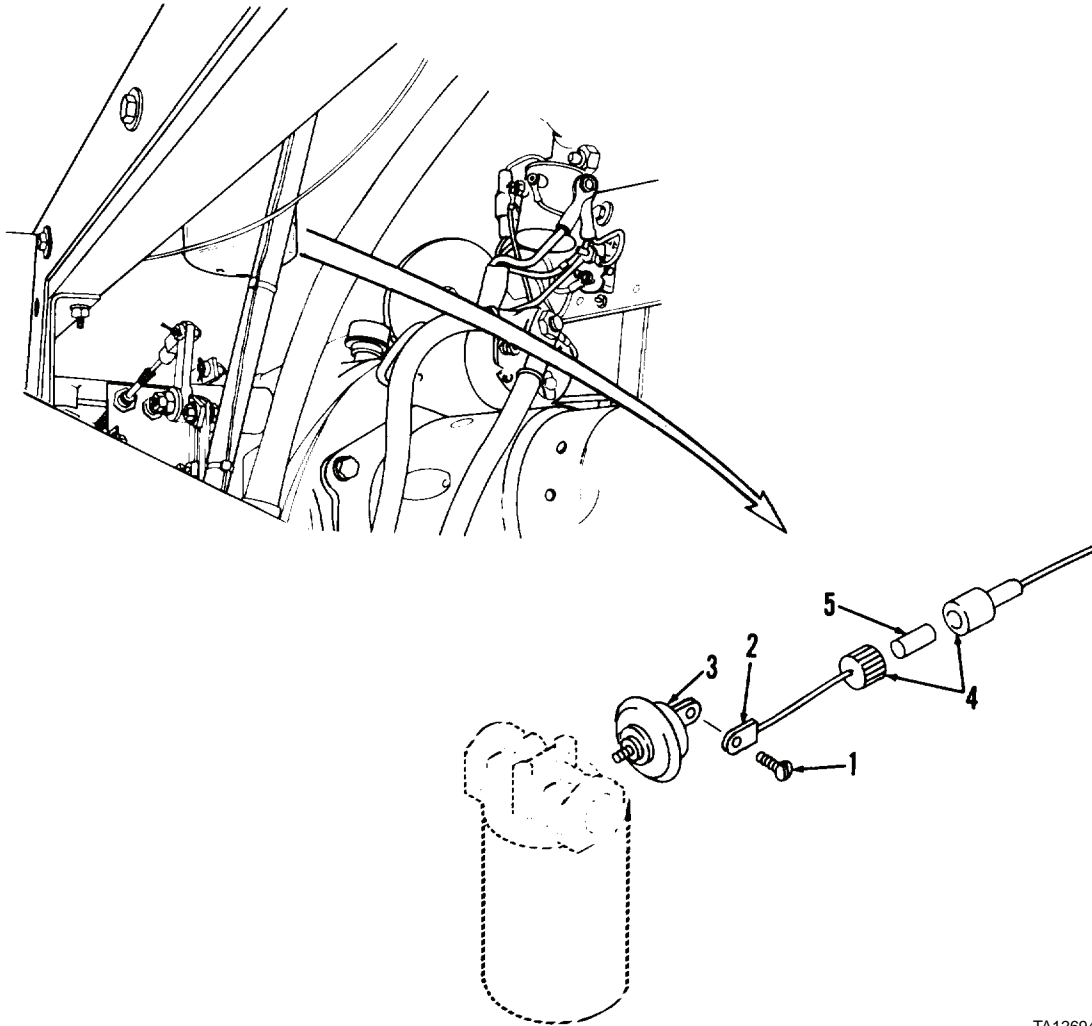

Figure 1. Hydraulic Filter Restriction Switch.

TA126940

**END OF TASK**

**CLEANING****WARNING**

- Solvent cleaning compound MIL-PRF-680 Type III is an environmentally compliant and low toxic material. However, it may be irritating to the eyes and skin. Use protective gloves and goggles. Use in well-ventilated areas. Keep away from open flames and other sources of ignition. Failure to do so may result in injury or death to personnel.
  - Particles blown by compressed air are hazardous. DO NOT exceed 15 PSI (103 kPa) nozzle pressure when drying parts with compressed air. DO NOT direct compressed air against human skin. Make sure air stream is directed away from user and other personnel in the area. To prevent injury, user must wear protective goggles or face shield. Failure to follow this warning may result in injury to personnel.
1. Use solvent cleaning compound to clean screw (Figure 1, Item 1). Dry thoroughly with compressed air.
  2. Clean wire lead and terminal. Use solvent cleaning compound on connector and terminal only.

**END OF TASK****INSPECTION**

1. Inspect screw (Figure 1, Item 1) and switch (Figure 1, Item 3). Replace if worn or cracked, or if threads damaged.
2. Inspect wires. Replace if insulation frayed, or if conductor broken.

**END OF TASK****INSTALLATION**

1. Position resistor (Figure 1, Item 5) in retainer halves (Figure 1, Item 4).
2. Connect retainer halves (Figure 1, Item 4) to secure resistor (Figure 1, Item 5).
3. Install switch (Figure 1, Item 3) and tighten.
4. Install wire lead (Figure 1, Item 2) and screw (Figure 1, Item 1) and tighten screw until wire lead is securely mounted to terminal of switch (Figure 1, Item 3).
5. Use silicone rubber sealer to seal wire lead (Figure 1, Item 2) and terminal.

**END OF TASK****END OF WORK PACKAGE**





---

# ORGANIZATIONAL MAINTENANCE INSTRUCTIONS

## STOP LIGHT SWITCH REPLACEMENT

Removal, Cleaning, Inspection, Installation

---

### INITIAL SETUP

#### Maintenance Level

Organizational

#### Tools and Special Tools

Tool kit, general mechanic's (Item 15, WP 0309)

Shop equipment, common no. 1 (Item 2, WP 0309)

#### Materials/Parts

Cleaning compound, solvent (Item 10, WP 0310)

Rag, wiping (Item 26, WP 0310)

RTV sealant (Item 31, WP 0310)

#### Equipment Condition

Engine OFF

Ignition switch in OFF position and key removed

---

### REMOVAL

1. Disconnect two wire leads from stop light switch at rear of brake master cylinder under driver's seat, on left side.
2. Remove stop light switch from brake master cylinder.

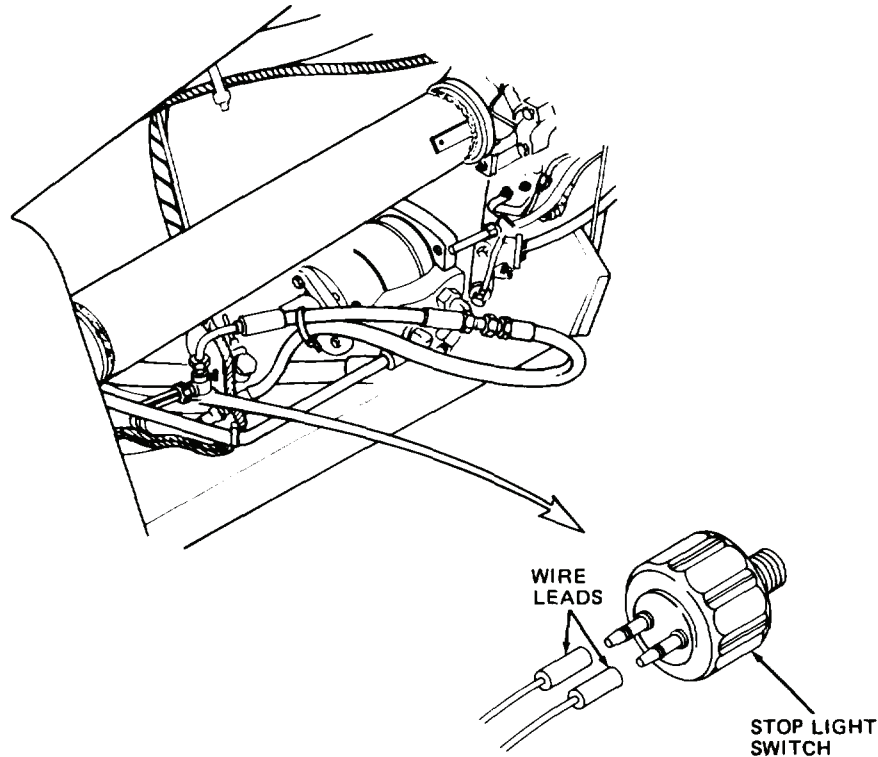

TA126941

Figure 1. Stop Light Switch and Connectors.

END OF TASK

**CLEANING****WARNING**

Solvent cleaning compound MIL-PRF-680 Type III is an environmentally compliant and low toxic material. However, it may be irritating to the eyes and skin. Use protective gloves and goggles. Use in well-ventilated areas. Keep away from open flames and other sources of ignition. Failure to do so may result in injury or death to personnel.

Clean wire leads and switch terminals. Use solvent cleaning compound on terminals and connectors only.

**END OF TASK****INSPECTION**

Inspect wires. Replace if insulation frayed or if conductors broken.

**END OF TASK****INSTALLATION**

1. Install stop light switch at rear of brake master cylinder under driver's seat, on left side, and tighten switch.
2. Install two wire leads on stop light switch.
3. Use silicone rubber sealer to seal two wire leads and terminals.

**END OF TASK****END OF WORK PACKAGE**

---

# ORGANIZATIONAL MAINTENANCE INSTRUCTIONS

## HORN REPLACEMENT (MODEL 207)

Removal, Cleaning, Inspection, Installation/Replacement

---

### INITIAL SETUP

#### Maintenance Level

Organizational

#### Tools and Special Tools

Tool kit, general mechanic's (Item 15, WP 0309)

Shop equipment, common no. 1 (Item 2, WP 0309)

#### Materials/Parts

Cleaning compound, solvent (Item 10, WP 0310)

Rag, wiping (Item 26, WP 0310)

Tag, marker (Item 33, WP 0310)

#### Equipment Condition

Engine OFF

Battery ground cable disconnected (WP 0133)

---

**NOTE**

Tag all electrical leads.

**REMOVAL**

1. Disconnect two wire leads (Figure 1, Item 1) from terminals of horn (Figure 1, Item 4).
2. Support horn (Figure 1, Item 4) and remove two capscrews (Figure 1, Item 2) and washers (Figure 1, Item 3).
3. Remove horn (Figure 1, Item 4) from fender support.
4. Remove grommet (Figure 1, Item 5) from fender support.

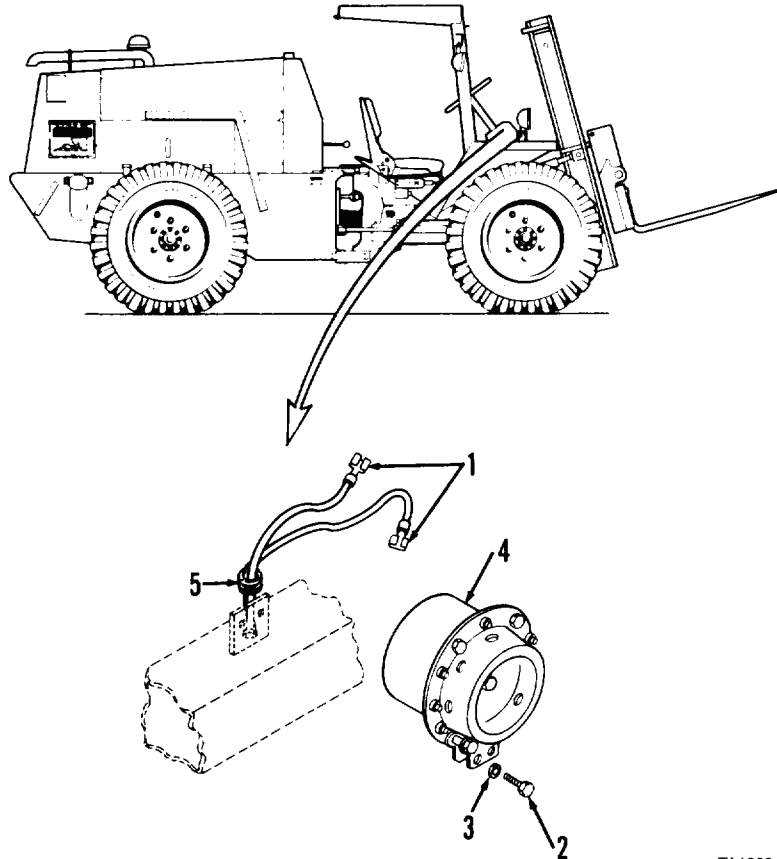

Figure 1. Horn Assembly.

TA126942

END OF TASK

**CLEANING****WARNING**

Solvent cleaning compound MIL-PRF-680 Type III is an environmentally compliant and low toxic material. However, it may be irritating to the eyes and skin. Use protective gloves and goggles. Use in well-ventilated areas. Keep away from open flames and other sources of ignition. Failure to do so may result in injury or death to personnel.

1. Wipe exterior of horn (Figure 1, Item 4) with rag moistened in solvent cleaning compound and dry thoroughly.
2. Clean wire leads and terminals. Use solvent cleaning compound on terminals and connectors only.

**END OF TASK****INSPECTION**

1. Inspect capscrews (Figure 1, Item 2) and washers (Figure 1, Item 3). Replace if worn, or if threads damaged.
2. Inspect grommet (Figure 1, Item 5). Replace if worn, cracked, or deteriorated.

**END OF TASK****INSTALLATION/REPLACEMENT**

1. Install grommet (Figure 1, Item 5) on fender support.
2. Position horn (Figure 1, Item 4) on bracket of fender support.
3. Install two capscrews (Figure 1, Item 2) and washers (Figure 1, Item 3) and tighten capscrews until horn (Figure 1, Item 4) is securely mounted.
4. Connect two wire leads (Figure 1, Item 1) to horn terminals.

**END OF TASK****END OF WORK PACKAGE**



---

## ORGANIZATIONAL MAINTENANCE INSTRUCTIONS

### HORN REPLACEMENT (MODEL 4-390)

Removal, Cleaning, Inspection, Installation

---

#### INITIAL SETUP

##### Maintenance Level

Organizational

##### Tools and Special Tools

Tool kit, general mechanic's (Item 15, WP 0309)

Shop equipment, common no. 1 (Item 2, WP 0309)

##### Materials/Parts

Cleaning compound, solvent (Item 10, WP 0310)

Rag, wiping (Item 26, WP 0310)

Tag, marker (Item 33, WP 0310)

##### Equipment Conditions

Engine OFF

Battery ground cable disconnected (WP 0134)

---

**REMOVAL**

1. At top of right-front fender support, tag and disconnect two wire leads (Figure 1, Item 1) from terminals of horn (Figure 1, Item 4).
2. While supporting horn (Figure 1, Item 4), remove two capscrews (Figure 1, Item 2), washers (Figure 1, Item 3), and horn (Figure 1, Item 4) from fender support.
3. Remove grommet (Figure 1, Item 5) from fender support.

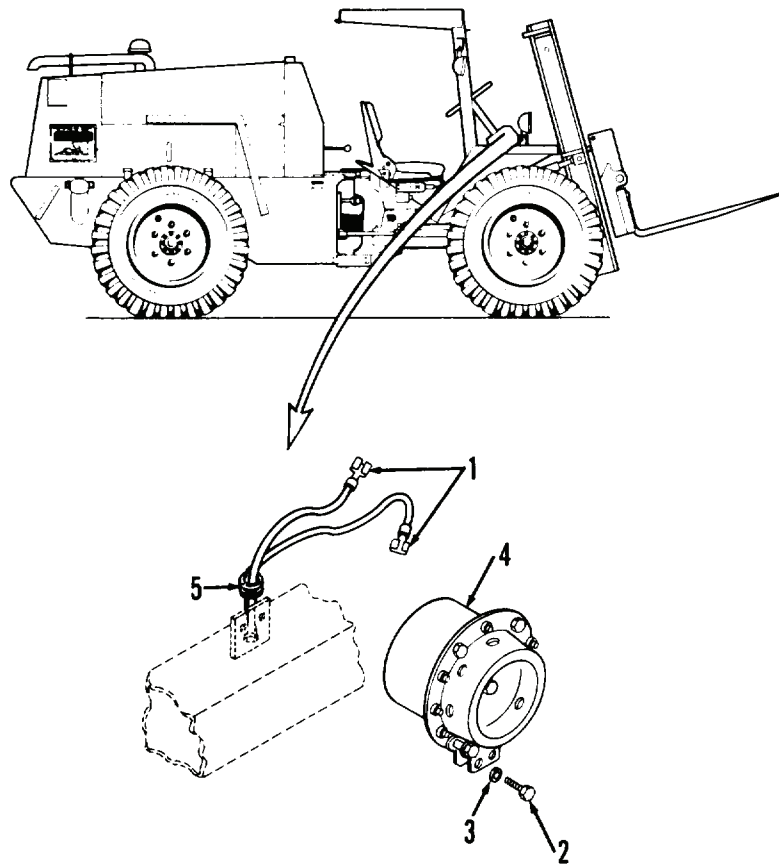
**Figure 1. Horn Assembly.**

TA126942

**END OF TASK**



**CLEANING****WARNING**

Solvent cleaning compound MIL-PRF-680 Type III is an environmentally compliant and low toxic material. However, it may be irritating to the eyes and skin. Use protective gloves and goggles. Use in well-ventilated areas. Keep away from open flames and other sources of ignition. Failure to do so may result in injury or death to personnel.

1. Clean horn exterior by wiping with rag moistened in solvent cleaning compound. Dry thoroughly.
2. Clean wire leads and terminals of horn with solvent cleaning compound on terminals and connectors only. Dry thoroughly.

**END OF TASK****INSPECTION**

1. Inspect horn. Replace if damaged.
2. Inspect capscrews and washers. Replace if worn or threads are damaged.
3. Inspect grommet. Replace if worn, cracked, or deteriorated.

**END OF TASK****INSTALLATION**

1. Install grommet (Figure 1, Item 5) on right fender support.
2. Position horn (Figure 1, Item 4) on bracket of right fender support.
3. Install horn (Figure 1, Item 4) with two washers (Figure 1, Item 3) and capscrews (Figure 1, Item 2).
4. Connect two wire leads (Figure 1, Item 1) to terminals of horn (Figure 1, Item 4).

**END OF TASK****END OF WORK PACKAGE**



---

# ORGANIZATIONAL MAINTENANCE INSTRUCTIONS

## HORN SWITCH MAINTENANCE

Removal, Cleaning, Inspection, Testing, Installation

---

### INITIAL SETUP

**Maintenance Level**

Organizational

**Tools and Special Tools**

Tool kit, general mechanic's (Item 15, WP 0309)

Shop equipment, common no. 1 (Item 2, WP 0309)

**Materials/Parts**

Cleaning compound, solvent (Item 10, WP 0310)

**Materials/Parts - Continued**

Rag, wiping (Item 26, WP 0310)

**Equipment Condition**

Engine OFF

Battery ground cable disconnected (Model 207)  
(WP 0133)

Battery ground cable disconnected (Model 4-390)  
(WP 0134)

---

**REMOVAL**

1. Remove cover (Figure 1, Item 1) and horn button (Figure 1, Item 2). Depress and rotate counterclockwise to release from tabs on base plate (Figure 1, Item 7).
2. Remove contact cup (Figure 1, Item 3), spring (Figure 1, Item 4), spring contact (Figure 1, Item 5), and ferrule (Figure 1, Item 10).
3. Remove three tapping screws (Figure 1, Item 6) and base plate (Figure 1, Item 7).
4. Disconnect harness connector (Figure 1, Item 8) from column terminal (Figure 1, Item 11).
5. Remove grommet (Figure 1, Item 9) from instrument panel.

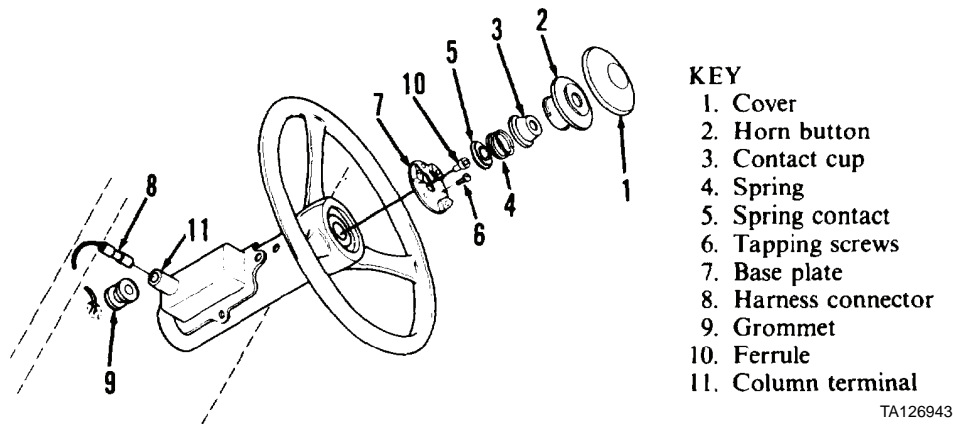

Figure 1. Horn Switch Assembly.

**END OF TASK****CLEANING**

**WARNING**

- Solvent cleaning compound MIL-PRF-680 Type III is an environmentally compliant and low toxic material. However, it may be irritating to the eyes and skin. Use protective gloves and goggles. Use in well-ventilated areas. Keep away from open flames and other sources of ignition. Failure to do so may result in injury or death to personnel.
- Particles blown by compressed air are hazardous. DO NOT exceed 15 PSI (103 kPa) nozzle pressure when drying parts with compressed air. DO NOT direct compressed air against human skin. Make sure air stream is directed away from user and other personnel in the area. To prevent injury, user must wear protective goggles or face shield. Failure to follow this warning may result in injury to personnel.

1. Use solvent cleaning compound to clean contacts (Figure 1, Items 3 and 5), spring (Figure 1, Item 4), and screws (Figure 1, Item 6). Dry thoroughly with compressed air.
2. Wipe cover (Figure 1, Item 1), horn button (Figure 1, Item 2), base plate (Figure 1, Item 7), and ferrule (Figure 1, Item 10) with a clean, dry rag.
3. Clean connector (Figure 1, Item 8) and terminal (Figure 1, Item 11). Use solvent cleaning compound on terminal and connector only.

**END OF TASK**

**INSPECTION**

1. Inspect spring (Figure 1, Item 4). Replace if coils bent or broken.
2. Inspect contacts (Figure 1, Items 3 and 5). Replace if cracked, corroded, or damaged.
3. Inspect cover (Figure 1, Item 1), horn button (Figure 1, Item 2), base plate (Figure 1, Item 7), and ferrule (Figure 1, Item 10). Replace if cracked, worn, or damaged.
4. Inspect grommet (Figure 1, Item 9). Replace if worn or deteriorated.

**END OF TASK****TESTING**

Set ohmmeter to lowest resistance range and connect leads to horn wire at ferrule (Figure 1, Item 10) and terminal (Figure 1, Item 11). Replace horn wire if ohmmeter indicates more than 0.5 Ohm (notify Direct Support Maintenance).

**END OF TASK****INSTALLATION**

1. Install grommet (Figure 1, Item 9) on fender support.
2. Connect harness connector (Figure 1, Item 8) to column terminal (Figure 1, Item 11).
3. Position base plate (Figure 1, Item 7) on steering wheel.
4. Install three tapping screws (Figure 1, Item 6) and tighten until base plate (Figure 1, Item 7) is securely mounted.
5. Install ferrule (Figure 1, Item 10), spring contact (Figure 1, Item 5), spring (Figure 1, Item 4), and contact cup (Figure 1, Item 3) on base plate (Figure 1, Item 7).
6. Install horn button (Figure 1, Item 2) and cover (Figure 1, Item 1). Depress and rotate clockwise to lock tabs on base plate (Figure 1, Item 7), then release.

**END OF TASK****END OF WORK PACKAGE**



---

## ORGANIZATIONAL MAINTENANCE INSTRUCTIONS

### BACK-UP ALARM REPLACEMENT (MODEL 207)

#### Removal, Cleaning, Inspection, Installation

---

#### INITIAL SETUP

**Maintenance Level**

Organizational

**Tools and Special Tools**

Tool kit, general mechanic's (Item 15, WP 0309)

Shop equipment, common no. 1 (Item 2, WP 0309)

**Materials/Parts**

Cleaning compound, solvent (Item 10, WP 0310)

Rag, wiping (Item 26, WP 0310)

**Materials/Parts - Continued**

Tag, marker (Item 33, WP 0310)

Lockwasher (4)

**References**

WP 0142

**Equipment Condition**

Battery ground cable disconnected (WP 0133)

Tow bar lowered to ground and grille opened  
(WP 0176)

---

**REMOVAL**

1. At top left of rear of vehicle, tag two wire terminals (Figure 1, Item 3) and terminal (Figure 1, Item 8) of ground wire.
2. Remove two nuts (Figure 1, Item 1), lockwashers (Figure 1, Item 2), and terminals (Figure 1, Item 3) from back-up alarm (Figure 1, Item 7). Discard lockwashers.
3. Remove two nuts (Figure 1, Item 4), lockwashers (Figure 1, Item 5), capscrews (Figure 1, Item 6), back-up alarm (Figure 1, Item 7), and terminal (Figure 1, Item 8) of ground wire from vehicle. Discard lockwashers.

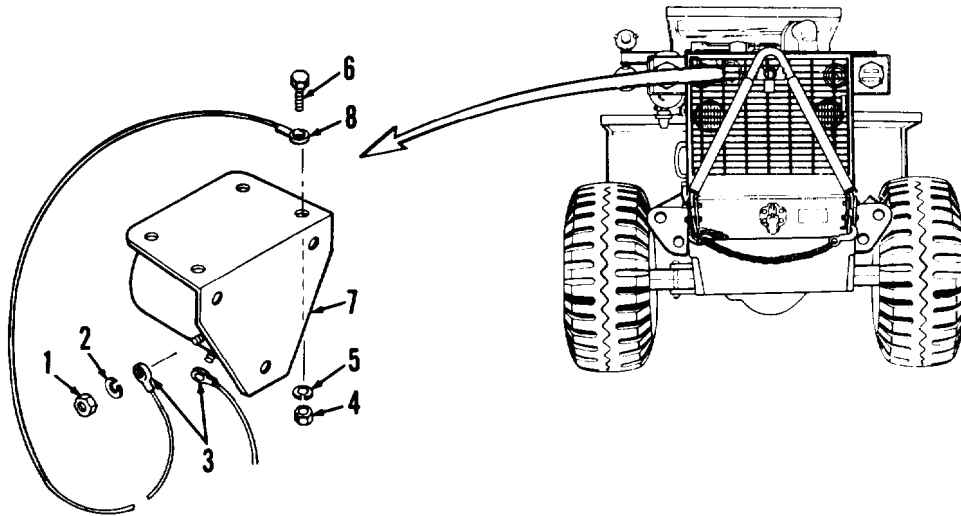

444-126944

**Figure 1. Back-Up Alarm Assembly.****END OF TASK**



**CLEANING**

- Solvent cleaning compound MIL-PRF-680 Type III is an environmentally compliant and low toxic material. However, it may be irritating to the eyes and skin. Use protective gloves and goggles. Use in well-ventilated areas. Keep away from open flames and other sources of ignition. Failure to do so may result in injury or death to personnel.
  - Particles blown by compressed air are hazardous. DO NOT exceed 15 PSI (103 kPa) nozzle pressure when drying parts with compressed air. DO NOT direct compressed air against human skin. Make sure air stream is directed away from user and other personnel in the area. To prevent injury, user must wear protective goggles or face shield. Failure to follow this warning may result in injury to personnel.
1. Clean electrical terminals with solvent cleaning compound. Dry with clean rags.
  2. Clean insulation of wire leads by wiping with a clean rag.
  3. Clean back-up alarm with clean water. Dry thoroughly.
  4. Clean all mounting hardware with solvent cleaning compound. Dry with compressed air.

**END OF TASK****INSPECTION**

1. Inspect wire lead of rear wiring harness. Repair if insulation is worn or missing or conductor is broken (refer to *Repair* in WP 0137).
2. Inspect terminals and conductor of ground wire. Replace or repair as necessary (refer to *Repair* in WP 0137).
3. Inspect mounting hardware. Replace if worn, corroded, or threads are damaged.

**END OF TASK****INSTALLATION**

1. Install terminal (Figure 1, Item 8) of ground wire and back-up alarm (Figure 1, Item 7) on vehicle with two capscrews (Figure 1, Item 6), new lockwashers (Figure 1, Item 5), and nuts (Figure 1, Item 4).
2. Install two terminals (Figure 1, Item 3) on back-up alarm (Figure 1, Item 7) with two new lockwashers (Figure 1, Item 2) and nuts (Figure 1, Item 1).

**END OF TASK****END OF WORK PACKAGE**



---

## ORGANIZATIONAL MAINTENANCE INSTRUCTIONS

### BACK-UP ALARM REPLACEMENT (MODEL 4-390)

Removal, Cleaning, Inspection, Installation

---

#### INITIAL SETUP

##### Maintenance Level

Organizational

##### Tools and Special Tools

Tool kit, general mechanic's (Item 15, WP 0309)

Shop equipment, common no. 1 (Item 2, WP 0309)

##### Materials/Parts

Cleaning compound, solvent (Item 10, WP 0310)

##### Materials/Parts - Continued

Rag, wiping (Item 26, WP 0310)

Tag, marker (Item 33, WP 0310)

Lockwasher (3)

##### Equipment Condition

Engine OFF

Battery ground cable disconnected (WP 0134)

Tow bar lowered to ground and grille opened  
(WP 0176)

---

**REMOVAL****NOTE**

Tag all electrical leads before disconnecting.

1. Remove two nuts (Figure 1, Item 1), lockwashers (Figure 1, Item 2), and capscrews (Figure 1, Item 3) to separate back-up alarm from radiator shroud (Figure 1, Item 5). Discard lockwashers.
2. Remove two nuts (Figure 1, Item 6) and wires (Figure 1, Item 7) of rear wiring harness from terminals of back-up alarm.
3. Push two wires (Figure 1, Item 7) out through lower-left hole of back-up alarm.
4. Remove nut (Figure 1, Item 8), lockwasher (Figure 1, Item 9), capscrew (Figure 1, Item 10), and cable clamp (Figure 1, Item 11) from rear upper-right hole of back-up alarm.
5. Remove cable clamp (Figure 1, Item 11) from around wiring harness.

**END OF TASK****CLEANING****WARNING**

- Solvent cleaning compound MIL-PRF-680 Type III is an environmentally compliant and low toxic material. However, it may be irritating to the eyes and skin. Use protective gloves and goggles. Use in well-ventilated areas. Keep away from open flames and other sources of ignition. Failure to do so may result in injury or death to personnel.
  - Particles blown by compressed air are hazardous. DO NOT exceed 15 PSI (103 kPa) nozzle pressure when drying parts with compressed air. DO NOT direct compressed air against human skin. Make sure air stream is directed away from user and other personnel in the area. To prevent injury, user must wear protective goggles or face shield. Failure to follow this warning may result in injury to personnel.
1. Use solvent cleaning compound to clean all hardware. Dry thoroughly with compressed air.
  2. Use solvent cleaning compound to clean wire terminals and alarm terminals. Dry thoroughly with compressed air.

**END OF TASK****INSPECTION**

1. Inspect hardware. Replace if worn, or if threads damaged.
2. Inspect harness wires. Replace if insulation frayed, or if conductors broken.

INSPECTION - CONTINUED

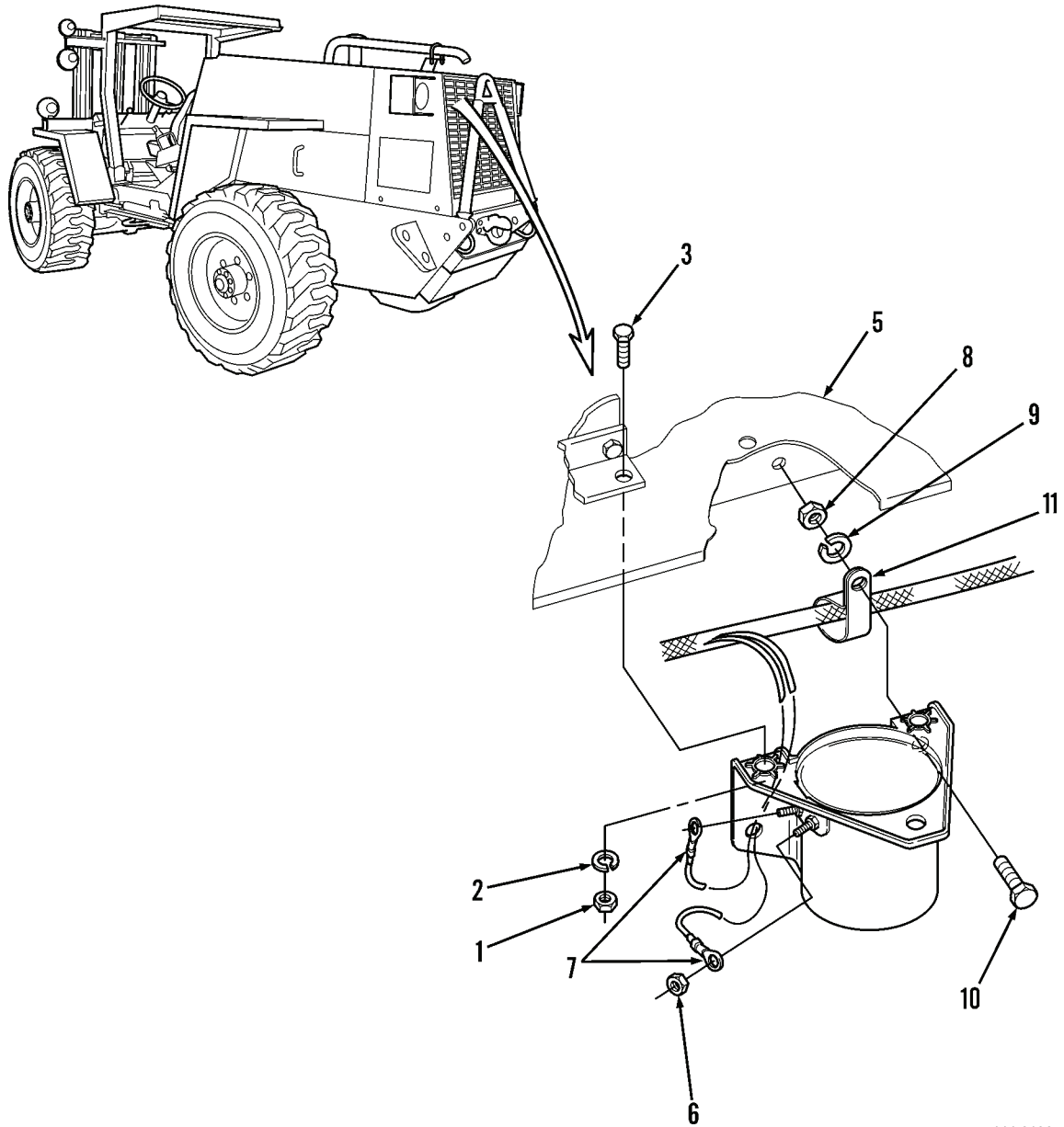

444-0130

Figure 1. Back-Up Alarm Assembly.

END OF TASK

**INSTALLATION**

1. Position cable clamp (Figure 2, Item 11) around wiring harness.
2. Install cable clamp (Figure 2, Item 11), capscrew (Figure 2, Item 10), new lockwasher (Figure 2, Item 9), and nut (Figure 2, Item 8) in rear upper-right hole of back-up alarm.
3. Push two wires (Figure 2, Item 7) of wiring harness through lower-left hole of back-up alarm.
4. Install two wires (Figure 2, Item 7) and nuts (Figure 2, Item 6) on terminals of back-up alarm.
5. Position back-up alarm on radiator shroud (Figure 2, Item 5).
6. Install two capscrews (Figure 2, Item 3), new lockwashers (Figure 2, Item 2), and nuts (Figure 2, Item 1).

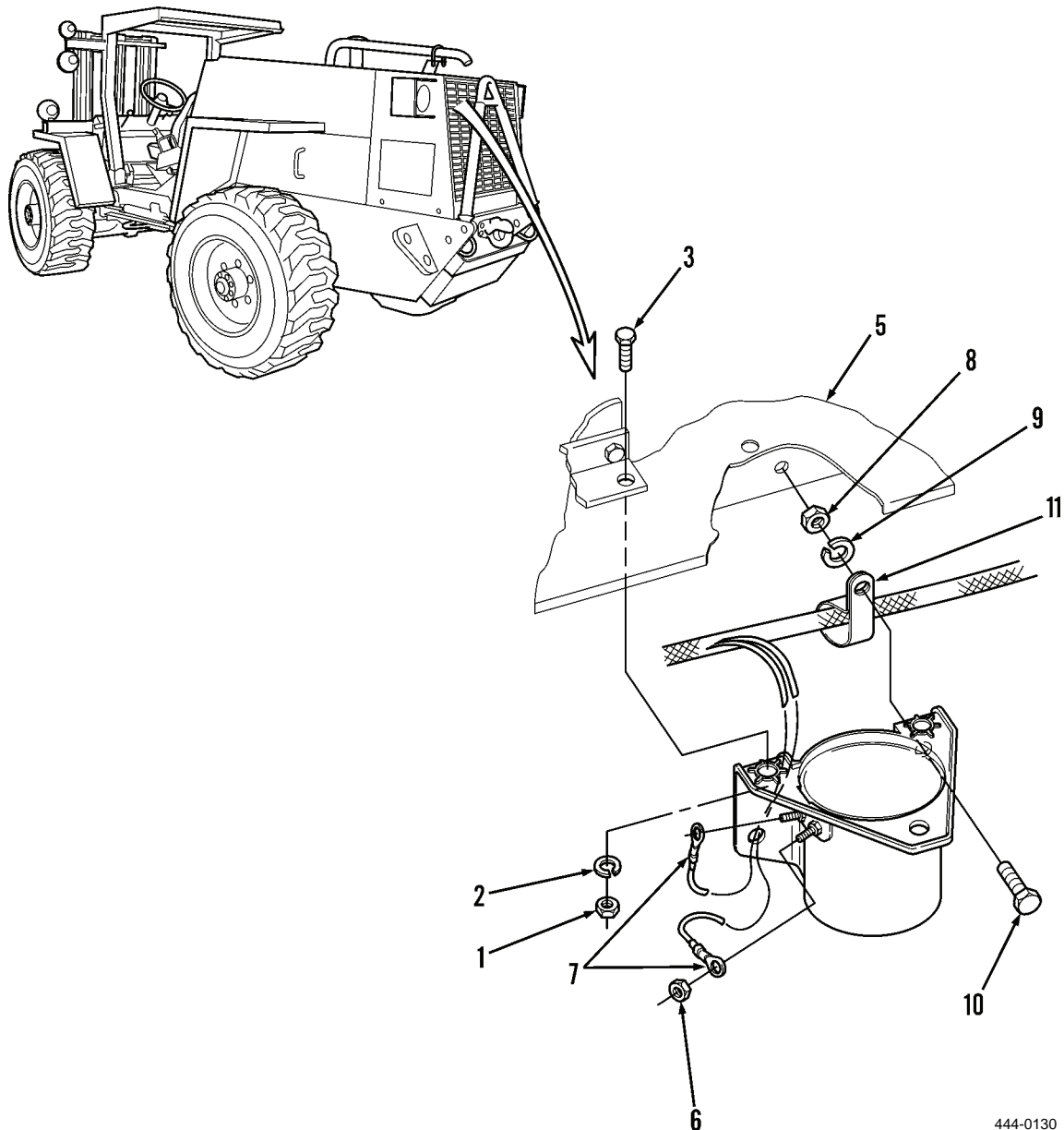
**Figure 2. Back-Up Alarm Assembly.**

444-0130

**END OF TASK****END OF WORK PACKAGE**

---

# ORGANIZATIONAL MAINTENANCE INSTRUCTIONS

## BATTERY COVER MAINTENANCE

Removal, Disassembly, Cleaning, Inspection, Assembly, Installation

---

### INITIAL SETUP

#### Maintenance Level

Organizational

#### Tools and Special Tools

Tool kit, general mechanic's (Item 15, WP 0309)

Shop equipment, common no. 1 (Item 2, WP 0309)

#### Materials/Parts

Cleaning compound, solvent (Item 10, WP 0310)

Rag, wiping (Item 26, WP 0310)

Lockwasher (2)

#### Equipment Condition

Tow bar lowered to ground and grille opened (WP 0176)

---

### REMOVAL

1. At rear of vehicle, depress and turn two fasteners 1/4 turn counterclockwise.
2. Grasp handle of battery cover and pull battery cover straight back to remove from vehicle.

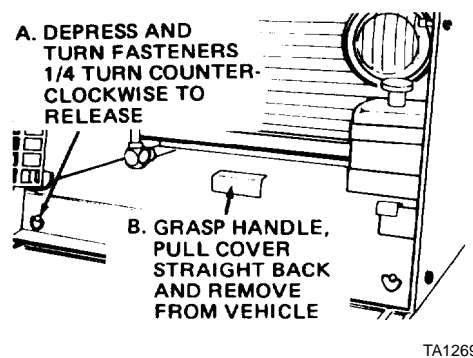
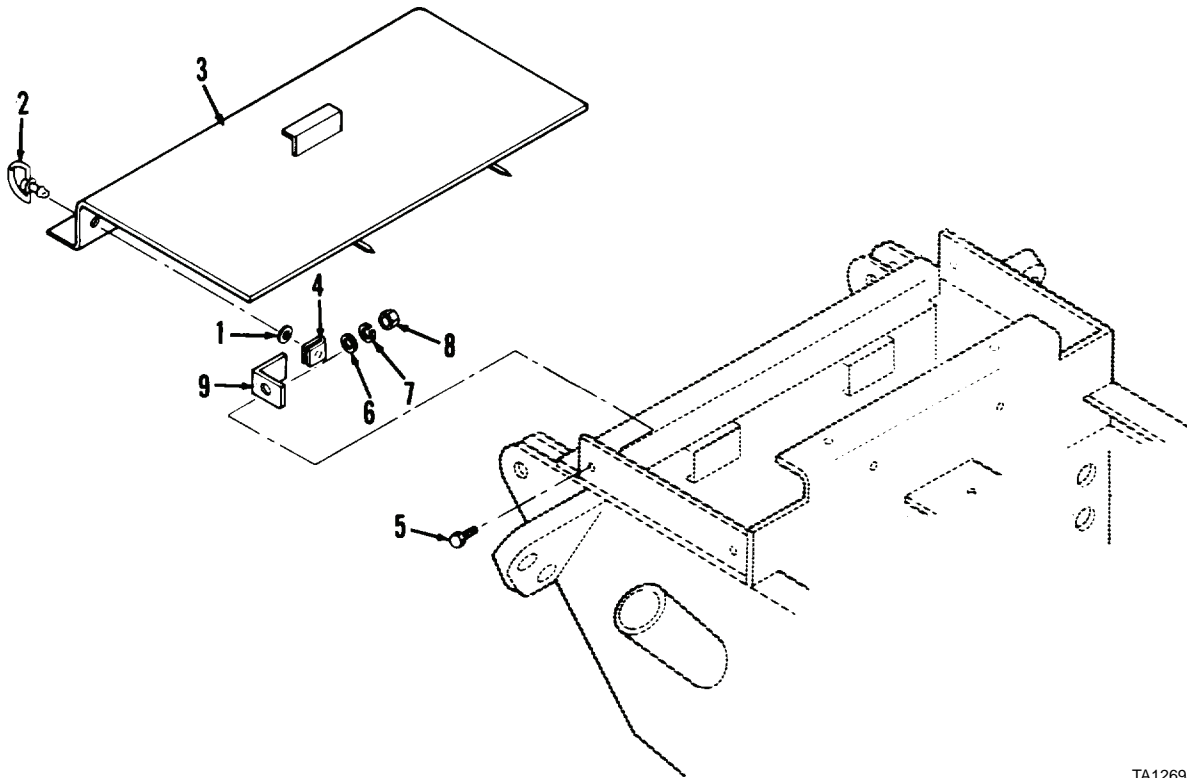

Figure 1. Battery Cover.

### END OF TASK

**DISASSEMBLY**

1. Remove two split rings (Figure 2, Item 1) and fasteners (Figure 2, Item 2) from battery cover (Figure 2, Item 3).
2. Remove retainer (Figure 2, Item 4) from each of two brackets (Figure 2, Item 9).
3. Remove two capscrews (Figure 2, Item 5), washers (Figure 2, Item 6), lockwashers (Figure 2, Item 7), nuts (Figure 2, Item 8), and brackets (Figure 2, Item 9) from battery cover (Figure 2, Item 3). Discard lockwashers.



TA126945

**Figure 2. Battery Cover Assembly.****END OF TASK**



**CLEANING****WARNING**

- Solvent cleaning compound MIL-PRF-680 Type III is an environmentally compliant and low toxic material. However, it may be irritating to the eyes and skin. Use protective gloves and goggles. Use in well-ventilated areas. Keep away from open flames and other sources of ignition. Failure to do so may result in injury or death to personnel.
- Particles blown by compressed air are hazardous. DO NOT exceed 15 PSI (103 kPa) nozzle pressure when drying parts with compressed air. DO NOT direct compressed air against human skin. Make sure air stream is directed away from user and other personnel in the area. To prevent injury, user must wear protective goggles or face shield. Failure to follow this warning may result in injury to personnel.

Clean all parts with solvent cleaning compound. Dry thoroughly with compressed air.

**END OF TASK****INSPECTION**

1. Inspect battery cover and two brackets. Replace if cracked, worn, or damaged.
2. Inspect all mounting hardware. Replace if worn or threads are damaged.

**END OF TASK****ASSEMBLY**

1. Install two brackets (Figure 2, Item 9) on battery cover (Figure 2, Item 3) with two capscrews (Figure 2, Item 5), washers (Figure 2, Item 6), new lockwashers (Figure 2, Item 7), and nuts (Figure 2, Item 8).
2. Install retainer (Figure 2, Item 4) on each of two brackets (Figure 2, Item 9).
3. Install two fasteners (Figure 2, Item 2) and split rings (Figure 2, Item 1) on battery cover (Figure 2, Item 3).

**END OF TASK****INSTALLATION**

1. Install battery cover on vehicle by grasping handle of battery cover, positioning battery cover over batteries, and pushing battery cover forward.
2. Depress and turn two fasteners 1/4 turn clockwise to secure battery cover.

**END OF TASK****END OF WORK PACKAGE**



---

## ORGANIZATIONAL MAINTENANCE INSTRUCTIONS

### BATTERIES AND BATTERY CABLES REPLACEMENT (MODEL 207)

#### Removal, Cleaning, Inspection, Installation

---

#### INITIAL SETUP

**Maintenance Level**

Organizational

**Tools and Special Tools**

Tool kit, general mechanic's (Item 15, WP 0309)

Shop equipment, common no. 1 (Item 2, WP 0309)

**Materials/Parts**

Brush, wire (Item 8, WP 0310)

Cleaning compound, solvent (Item 10, WP 0310)

**Materials/Parts - Continued**

Cloth, crocus (Item 12, WP 0310)

Rag, wiping (Item 26, WP 0310)

Lockwasher

**References**

WP 0095

**Equipment Condition**

Tow bar lowered to ground and grille opened  
(WP 0176)

Battery cover removed (WP 0132)

---

---

**REMOVAL**

1. At ground cable (Figure 1, Item 1) at rear of vehicle, loosen nut of clamp, spread clamp terminal, and remove from negative post of one battery (Figure 1, Item 6).
2. At positive cable (Figure 1, Item 3), loosen nut of clamp, spread clamp terminal, and remove from positive post of other battery (Figure 1, Item 6).
3. At positive battery cable (Figure 1, Item 2), loosen two nuts, spread clamp terminals, and remove from posts of two batteries (Figure 1, Item 6).
4. Remove two capscrews (Figure 1, Item 4) and hold-down straps (Figure 1, Item 5) from batteries (Figure 1, Item 6).

**NOTE**

Note position and polarity of battery posts for installation.

5. Remove two batteries (Figure 1, Item 6) from battery compartment.
6. Remove positive cable terminal (Figure 1, Item 7) from starter solenoid terminal B (WP 0095).
7. Remove ground cable terminal (Figure 1, Item 8) from starter housing (WP 0095).
8. Remove nut (Figure 1, Item 9), lockwasher (Figure 1, Item 10), capscrew (Figure 1, Item 11), and clamp (Figure 1, Item 12) from cables (Figure 1, Items 1 and 3) and vehicle. Discard lockwasher.
9. Remove two cables (Figure 1, Items 1 and 3) and grommets (Figure 1, Item 13).

REMOVAL - CONTINUED

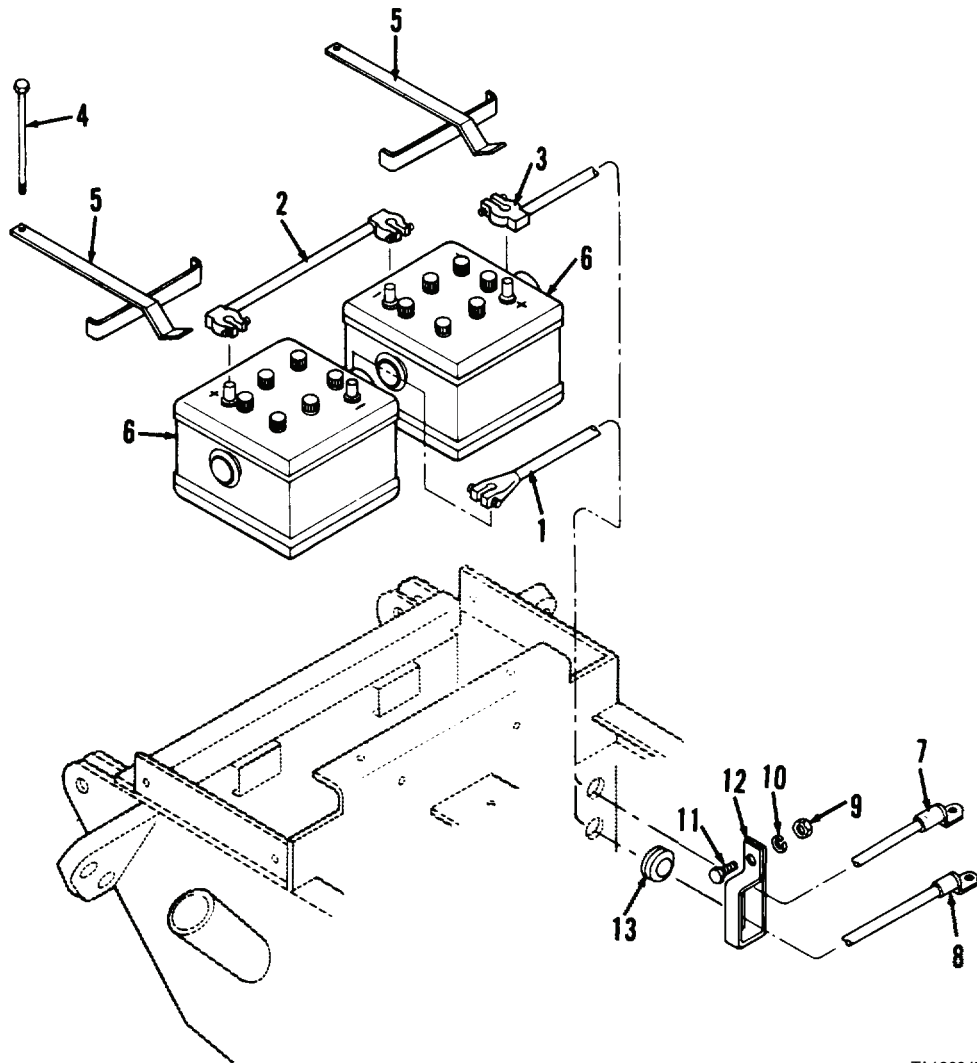

TA126947

Figure 1. Batteries and Battery Cables.

END OF TASK

**CLEANING**

- Solvent cleaning compound MIL-PRF-680 Type III is an environmentally compliant and low toxic material. However, it may be irritating to the eyes and skin. Use protective gloves and goggles. Use in well-ventilated areas. Keep away from open flames and other sources of ignition. Failure to do so may result in injury or death to personnel.
  - Particles blown by compressed air are hazardous. DO NOT exceed 15 PSI (103 kPa) nozzle pressure when drying parts with compressed air. DO NOT direct compressed air against human skin. Make sure air stream is directed away from user and other personnel in the area. To prevent injury, user must wear protective goggles or face shield. Failure to follow this warning may result in injury to personnel.
1. Clean hold-down straps, clamp, and mounting hardware with solvent cleaning compound. Dry with compressed air.
  2. Clean battery cables and grommet by wiping with clean, dry rag.
  3. Clean terminals of battery cables with solvent cleaning compound. Dry thoroughly.
  4. Clean clamps of battery cables with wire brush or crocus cloth.
  5. Clean exterior of batteries with water.
  6. Clean posts of batteries with solvent cleaning compound.

**END OF TASK****INSPECTION**

1. Inspect battery cables. Replace if insulation is worn or missing, conductors broken, or clamps and terminals damaged.
2. Inspect batteries. Replace if case is cracked or posts are damaged.
3. Inspect hold-down straps. Replace if cracked or corroded.
4. Inspect mounting hardware. Replace if worn, corroded, or threads are damaged.
5. Inspect grommet. Replace if worn or deteriorated.

**END OF TASK****INSTALLATION**

1. Install grommet (Figure 2, Item 13) and position two cables (Figure 2, Items 1 and 3) on vehicle.
2. Position clamp (Figure 2, Item 12) around cables (Figure 2, Items 1 and 3) and install on vehicle with capscrew (Figure 2, Item 11), new lockwasher (Figure 2, Item 10), and nut (Figure 2, Item 9).
3. Install ground cable terminal (Figure 2, Item 8) on starter housing (WP 0095).
4. Install positive cable terminal (Figure 2, Item 7) on starter solenoid terminal B (WP 0095).
5. Position two batteries (Figure 2, Item 6) in battery compartment.

## INSTALLATION - CONTINUED

## CAUTION

Do not over-tighten capscrews. Excessive tightening will deform battery case and damage batteries.

6. Install two hold-down straps (Figure 2, Item 5) with two capscrews (Figure 2, Item 4).
7. Position positive battery cable (Figure 2, Item 2) on posts of two batteries (Figure 2, Item 6) and tighten nuts of clamps.
8. Position positive cable (Figure 2, Item 3) on post of one battery (Figure 2, Item 6) and tighten nut of clamp.
9. Position ground cable (Figure 2, Item 1) on post of other battery (Figure 2, Item 6) and tighten nut of clamp.

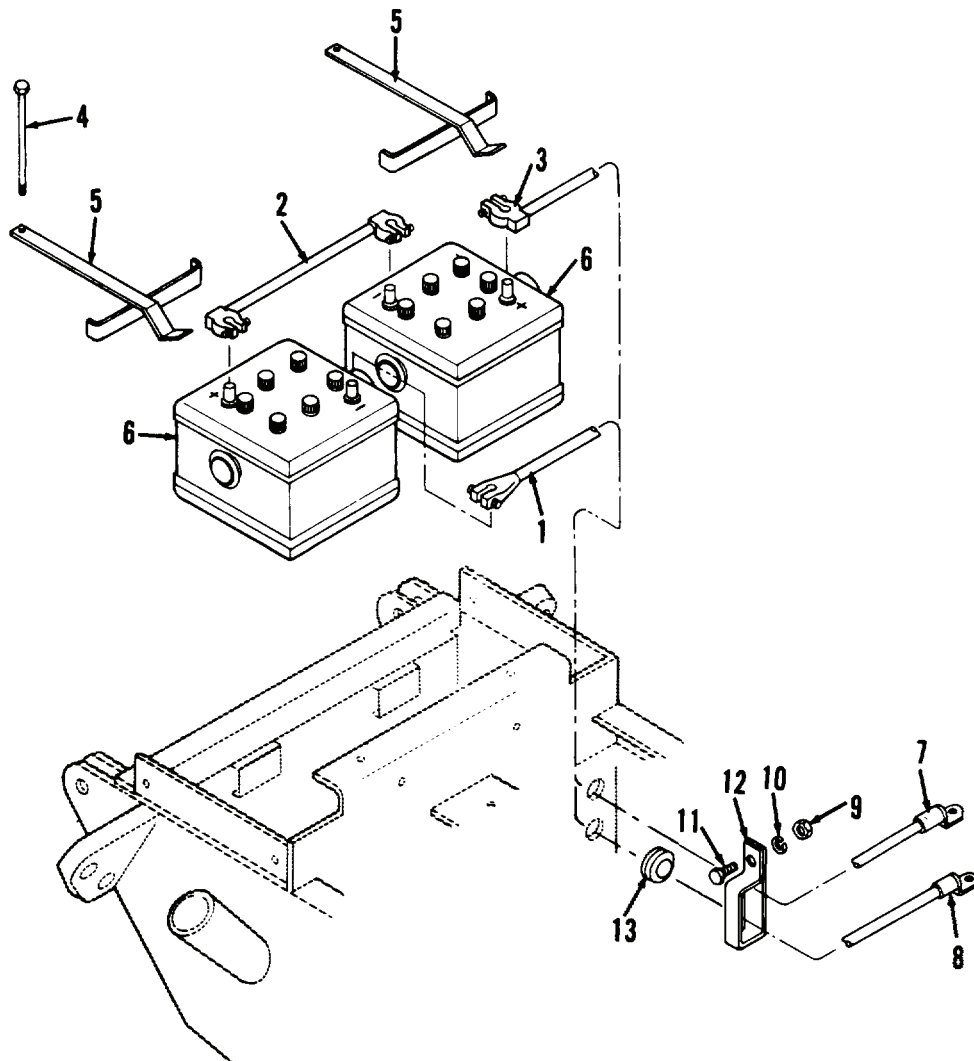

TA126947

Figure 2. Batteries and Battery Cables.

END OF TASK

END OF WORK PACKAGE





## ORGANIZATIONAL MAINTENANCE INSTRUCTIONS

### BATTERIES AND BATTERY CABLES REPLACEMENT (MODEL 4-390)

#### Removal, Cleaning, Inspection, Installation

#### INITIAL SETUP

##### Maintenance Level

Organizational

##### Tools and Special Tools

Tool kit, general mechanic's (Item 15, WP 0309)

Shop equipment, common no. 1 (Item 2, WP 0309)

##### Materials/Parts

Brush, wire (Item 8, WP 0310)

Cleaning compound, solvent (Item 10, WP 0310)

##### Materials/Parts - Continued

Cloth, crocus (Item 12, WP 0310)

Rag, wiping (Item 26, WP 0310)

Lockwasher (2)

##### Equipment Condition

Engine OFF

Ignition switch in OFF position and key removed

Tow bar lowered to ground and grille opened  
(WP 0176)

Battery cover removed (WP 0132)

#### REMOVAL



WARNING



- To avoid injury, eye protection and acid-resistant gloves must be worn when working around batteries. DO NOT smoke, use open flame, make sparks, or create other ignition sources around batteries. If a battery is giving off gases, it can explode and cause injury to personnel. Remove all jewelry such as rings, ID tags, watches, and bracelets. If jewelry or a tool contacts a battery terminal, a direct short will result in instant heating or electric shock, damage to equipment, and injury or death to personnel.
- Sulfuric acid contained in batteries can cause serious burns. If battery corrosion or electrolyte makes contact with skin, eyes, or clothing, take immediate action as follows to stop the corrosive burning effects:
  - (a) **Eyes.** Flush with cold water for no less than 15 minutes and seek medical attention immediately.
  - (b) **Skin.** Flush with large amounts of cold water until all acid is removed. Seek medical attention as required.
  - (c) **Internal.** If corrosion or electrolyte is ingested, drink large amounts of water or milk. Follow with milk of magnesia, beaten egg, or vegetable oil. Seek medical attention immediately.
  - (d) **Clothing/Equipment.** Wash area with large amounts of cold water. Neutralize acid with baking soda or household ammonia.
- Failure to follow these warnings may result in injury or death to personnel.

**REMOVAL - CONTINUED**

1. In battery compartment at rear of vehicle, pull back rubber cover, loosen nut, and remove ground cable clamp (Figure 1, Item 1) at end of negative battery cable (Figure 1, Item 2) from negative terminal of battery (Figure 1, Item 3).
2. At side of engine, remove capscrew (Figure 1, Item 5), ground cable terminal (Figure 1, Item 4), lockwasher (Figure 1, Item 6), and ground cable terminal at end of negative battery cable (Figure 1, Item 2). Discard lockwasher.
3. Remove negative battery cable (Figure 1, Item 2) and grommet (Figure 1, Item 7) from vehicle.
4. At positive terminal of battery (Figure 1, Item 10), pull back rubber cover, loosen nut, and remove positive cable clamp (Figure 1, Item 8) of positive battery cable (Figure 1, Item 9).
5. At positive terminal of starter, remove nut (Figure 1, Item 12), lockwasher (Figure 1, Item 13), and terminal (Figure 1, Item 11) of positive battery cable (Figure 1, Item 9). Discard lockwasher.
6. Remove positive battery cable (Figure 1, Item 9) and grommet (Figure 1, Item 14) from vehicle.
7. At positive terminal of battery (Figure 1, Item 3) and negative terminal of battery (Figure 1, Item 10), loosen two nuts and remove two cable clamps (Figure 1, Item 15) of battery cable (Figure 1, Item 16).
8. Remove battery cable (Figure 1, Item 16) from vehicle.
9. Remove two long capscrews (Figure 1, Item 17) and hold-down straps (Figure 1, Item 18).
10. Remove two batteries (Figure 1, Items 3 and 10) from vehicle.
11. Remove battery mat (Figure 1, Item 19) from vehicle.

**END OF TASK****CLEANING****WARNING**

- Solvent cleaning compound MIL-PRF-680 Type III is an environmentally compliant and low toxic material. However, it may be irritating to the eyes and skin. Use protective gloves and goggles. Use in well-ventilated areas. Keep away from open flames and other sources of ignition. Failure to do so may result in injury or death to personnel.
  - Particles blown by compressed air are hazardous. **DO NOT** exceed 15 PSI (103 kPa) nozzle pressure when drying parts with compressed air. **DO NOT** direct compressed air against human skin. Make sure air stream is directed away from user and other personnel in the area. To prevent injury, user must wear protective goggles or face shield. Failure to follow this warning may result in injury to personnel.
1. Clean hold-down straps and hardware with solvent cleaning compound. Dry thoroughly with compressed air
  2. Clean battery cables and grommets by wiping with a clean, dry rag.
  3. Clean batteries with clean water on exterior only.
  4. Clean battery terminals and clamps of battery cables using a wire brush or crocus cloth to remove deposits
  5. Clean terminals of battery cables with solvent cleaning compound on terminals only.

CLEANING - CONTINUED

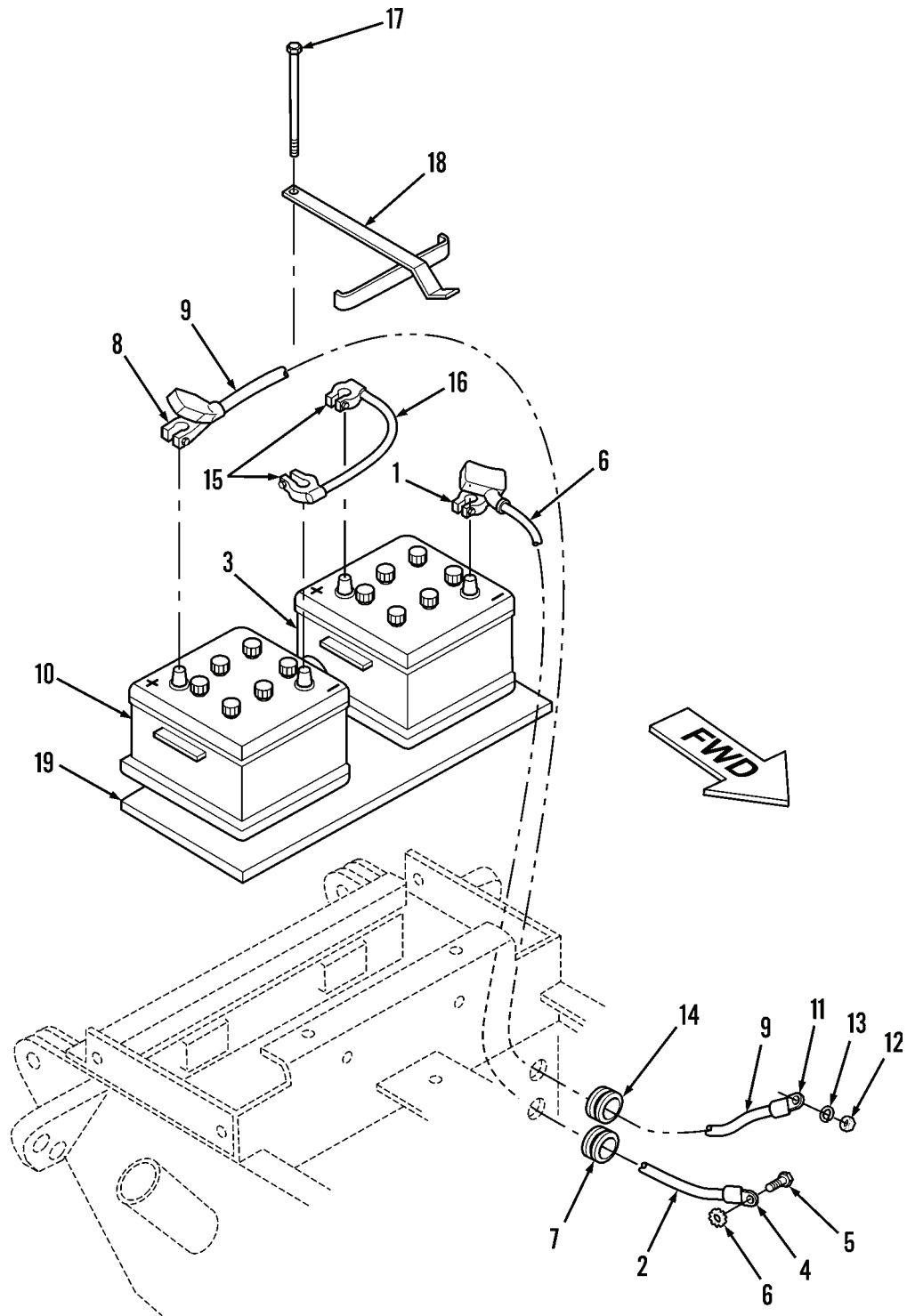

444-0132

Figure 1. Batteries and Battery Cables.

END OF TASK

---

**INSPECTION**

1. Inspect all hardware. Replace if worn or corroded, or if threads are damaged.
2. Inspect battery cables. Replace if insulation is frayed, conductors are broken, or clamps and terminals are damaged.
3. Inspect batteries. Replace if case is cracked or terminals are damaged.
4. Inspect hold-down straps. Replace if cracked or corroded.
5. Inspect grommets. Replace if worn or deteriorated.

**END OF TASK****INSTALLATION**

1. In battery compartment at rear of vehicle, install battery mat (Figure 2, Item 19).
2. Position two batteries (Figure 2, Items 10 and 3) in battery compartment.

**CAUTION**

Do not over-tighten capscrews. Excessive tightening will deform battery case and damage battery.

3. Install two hold-down straps (Figure 2, Item 18) with two long capscrews (Figure 2, Item 17).
4. Position battery cable (Figure 2, Item 16) on batteries (Figure 2, Items 10 and 3).
5. Install cable clamps (Figure 2, Item 15) of battery cable (Figure 2, Item 16) on negative terminal of battery (Figure 2, Item 10) and positive terminal of battery (Figure 2, Item 3). Tighten two nuts on cable clamps.
6. Install grommet (Figure 2, Item 14) and position positive battery cable (Figure 2, Item 9) on vehicle.
7. Install positive cable terminal (Figure 2, Item 11) at end of positive battery cable (Figure 2, Item 9) on positive terminal of starter with new lockwasher (Figure 2, Item 13) and nut (Figure 2, Item 12).
8. Install positive cable clamp (Figure 2, Item 8) of positive battery cable (Figure 2, Item 9) on positive terminal of battery (Figure 2, Item 10). Tighten nut and push rubber cover over cable clamp.
9. Install grommet (Figure 2, Item 7) and position negative battery cable (Figure 2, Item 2) on vehicle.
10. Install ground cable terminal (4) at end of negative battery cable (Figure 2, Item 2) on positive terminal of starter with new lockwasher (Figure 2, Item 6) and capscrew (Figure 2, Item 5).
11. Install ground cable clamp (Figure 2, Item 1) of negative battery cable (Figure 2, Item 2) on negative terminal of battery (Figure 2, Item 3). Tighten nut and push rubber cover over clamp.

INSTALLATION - CONTINUED

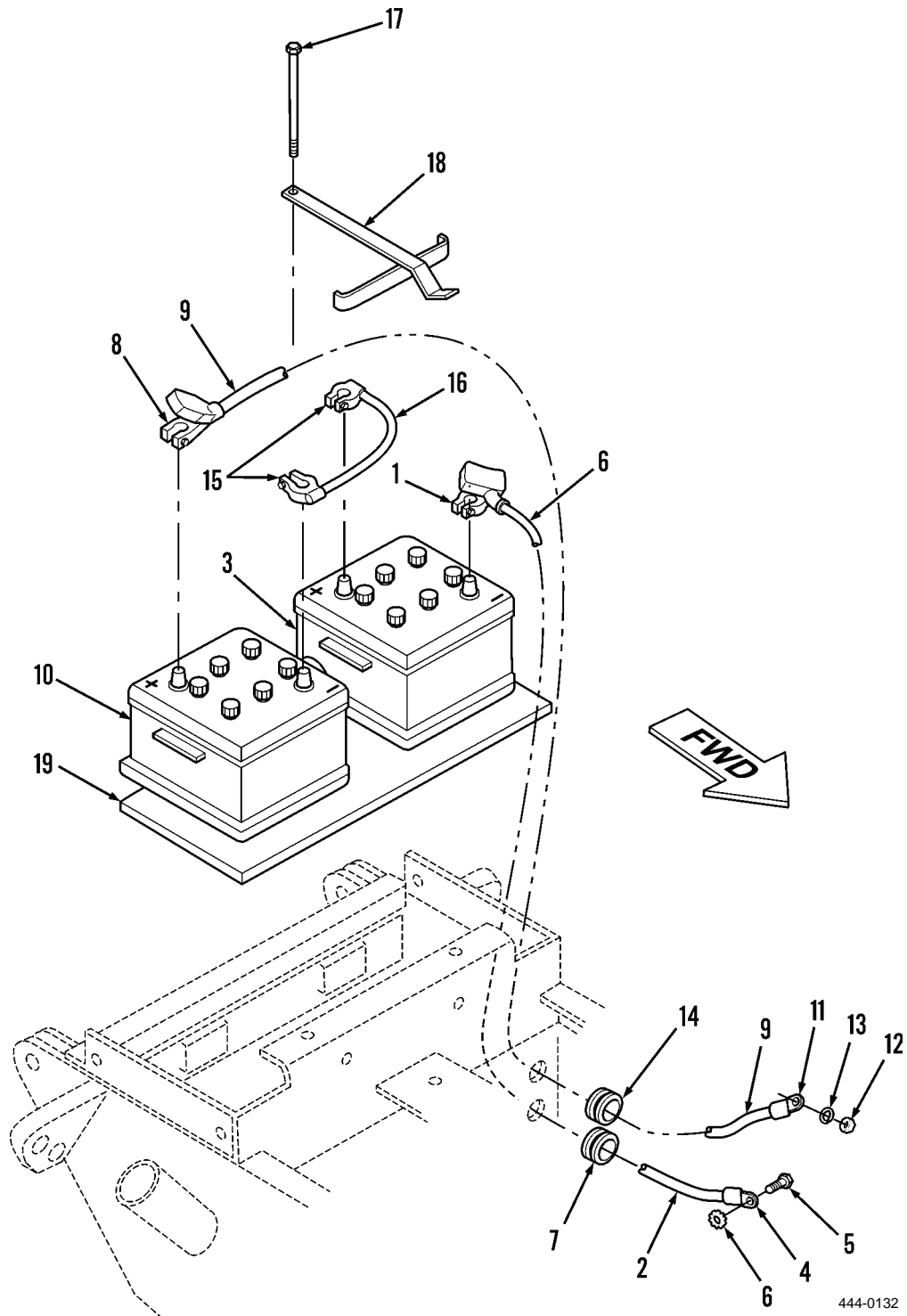

Figure 2. Batteries and Battery Cables.

END OF TASK

END OF WORK PACKAGE



# ORGANIZATIONAL MAINTENANCE INSTRUCTIONS

## FRONT WIRING HARNESS MAINTENANCE (MODEL 207)

### Cleaning, Inspection, Repair, Testing

#### INITIAL SETUP

##### Maintenance Level

Organizational

##### Tools and Special Tools

Tool kit, general mechanic's (Item 15, WP 0309)

Shop equipment, common no. 1 (Item 2, WP 0309)

##### Materials/Parts

Cleaning compound, solvent (Item 10, WP 0310)

##### Materials/Parts - Continued

Rag, wiping (Item 26, WP 0310)

Tape, electrical (Item 35, WP 0310)

##### References

WP 0240

WP 0306

##### Equipment Condition

Battery ground cable disconnected (WP 0133)

#### CLEANING

1. Clean insulation of front wiring harness wires by wiping with a clean rag.



**WARNING**



Solvent cleaning compound MIL-PRF-680 Type III is an environmentally compliant and low toxic material. However, it may be irritating to the eyes and skin. Use protective gloves and goggles. Use in well-ventilated areas. Keep away from open flames and other sources of ignition. Failure to do so may result in injury or death to personnel.

2. Clean electrical connectors and terminals with solvent cleaning compound. Dry with clean rags.

#### END OF TASK

**INSPECTION**

1. Inspect wire leads of front wiring harness. Repair if insulation is worn or missing or if conductor is broken (refer to *Repair* in this work package).
2. Inspect front harness connector. Replace front wiring harness if connector is damaged (WP 0240).

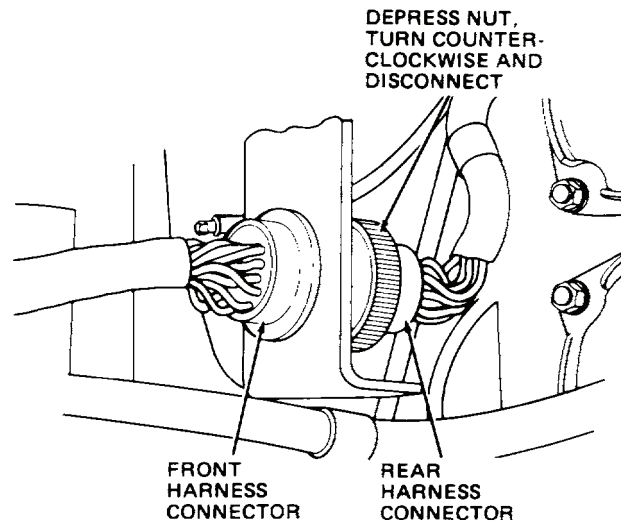

TA126951.1

**Figure 1. Front and Rear Harness Connectors.**

3. Inspect all other connectors and terminals. Replace if bent, missing, or damaged (refer to *Repair* in this work package).



INSPECTION - CONTINUED

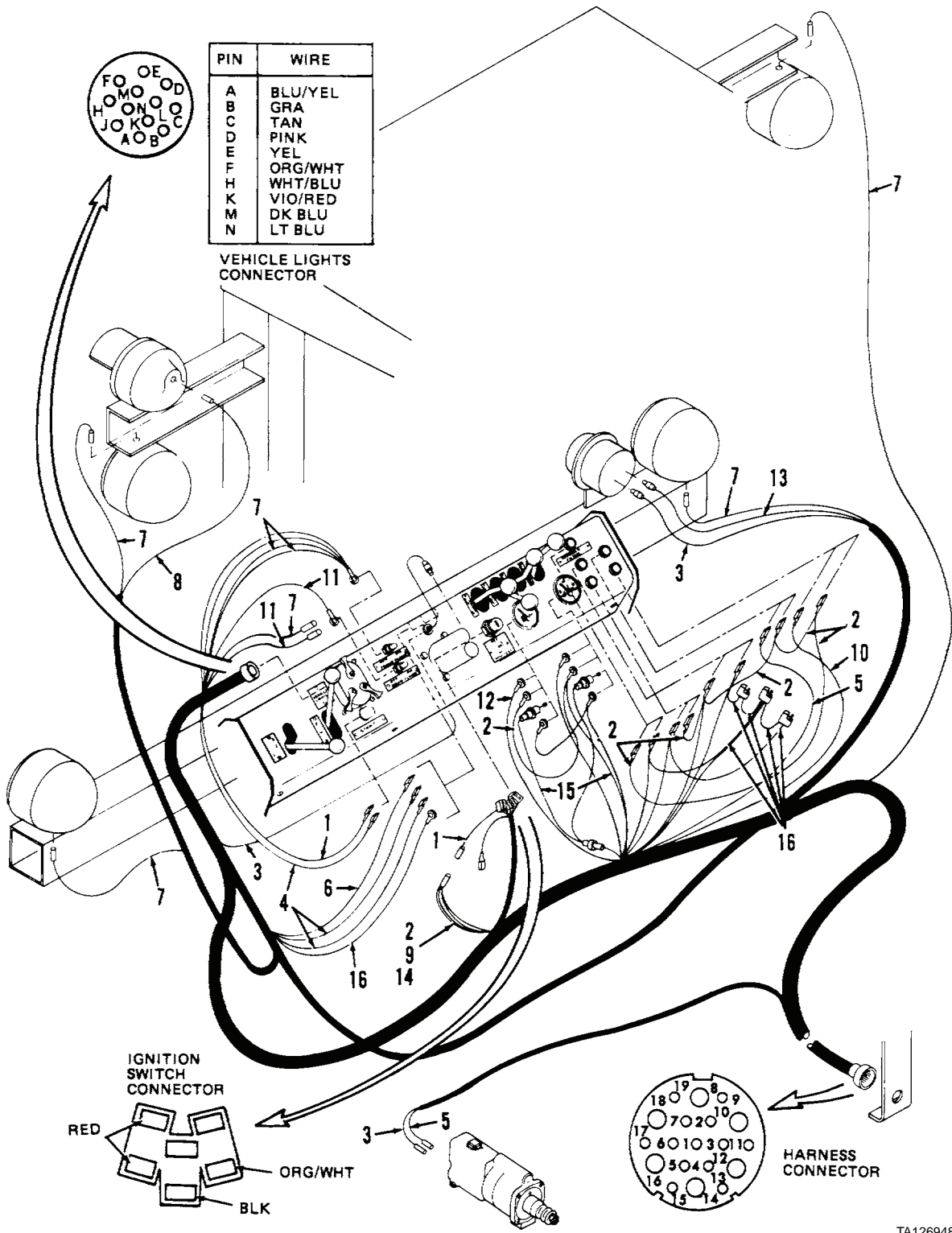

Figure 2. Front Harness Connections.

TA126948

**END OF TASK****REPAIR**

1. Repair wire leads of front wiring harness by wrapping electrical tape over insulation that is worn or missing.

**NOTE**

- If defective wire is accessible, cut a length of wire and splice using insulating splice connectors. Gage of replacement wire must be equal to or greater than gage of defective wire.
  - If wire is not accessible, replace front wiring harness (WP 0240).
2. Repair wire lead of front wiring harness by replacing defective wire.

**NOTE**

Cut wire close to defective wire terminal or connector. Strip insulation to depth of terminal well, and crimp new terminal or connector to wire.

3. Repair front wiring harness by replacing defective terminal or connector.

**END OF TASK****TESTING**

1. Test front wiring harness by starting engine, turning on all lights, depressing service brake pedal, and observing that all lights/indicators/gages are operating. If any abnormal indications are observed, notify Direct Support Maintenance.
2. To perform a continuity test of front wiring harness using an ohmmeter, refer to electrical system wiring schematic located in WP 0306.

**END OF TASK****END OF WORK PACKAGE**

---

## ORGANIZATIONAL MAINTENANCE INSTRUCTIONS

### FRONT WIRING HARNESS MAINTENANCE (MODEL 4-390)

Cleaning, Inspection, Repair, Testing

---

#### INITIAL SETUP

**Maintenance Level**

Organizational

**Tools and Special Tools**

Tool kit, general mechanic's (Item 15, WP 0309)

Shop equipment, common no. 1 (Item 2, WP 0309)

**Materials/Parts**

Cleaning compound, solvent (Item 10, WP 0310)

**Materials/Parts - Continued**

Rag, wiping (Item 26, WP 0310)

**References**

WP 0005

WP 0306

**Equipment Condition**

Engine OFF

Battery ground cable disconnected (WP 0134)

---

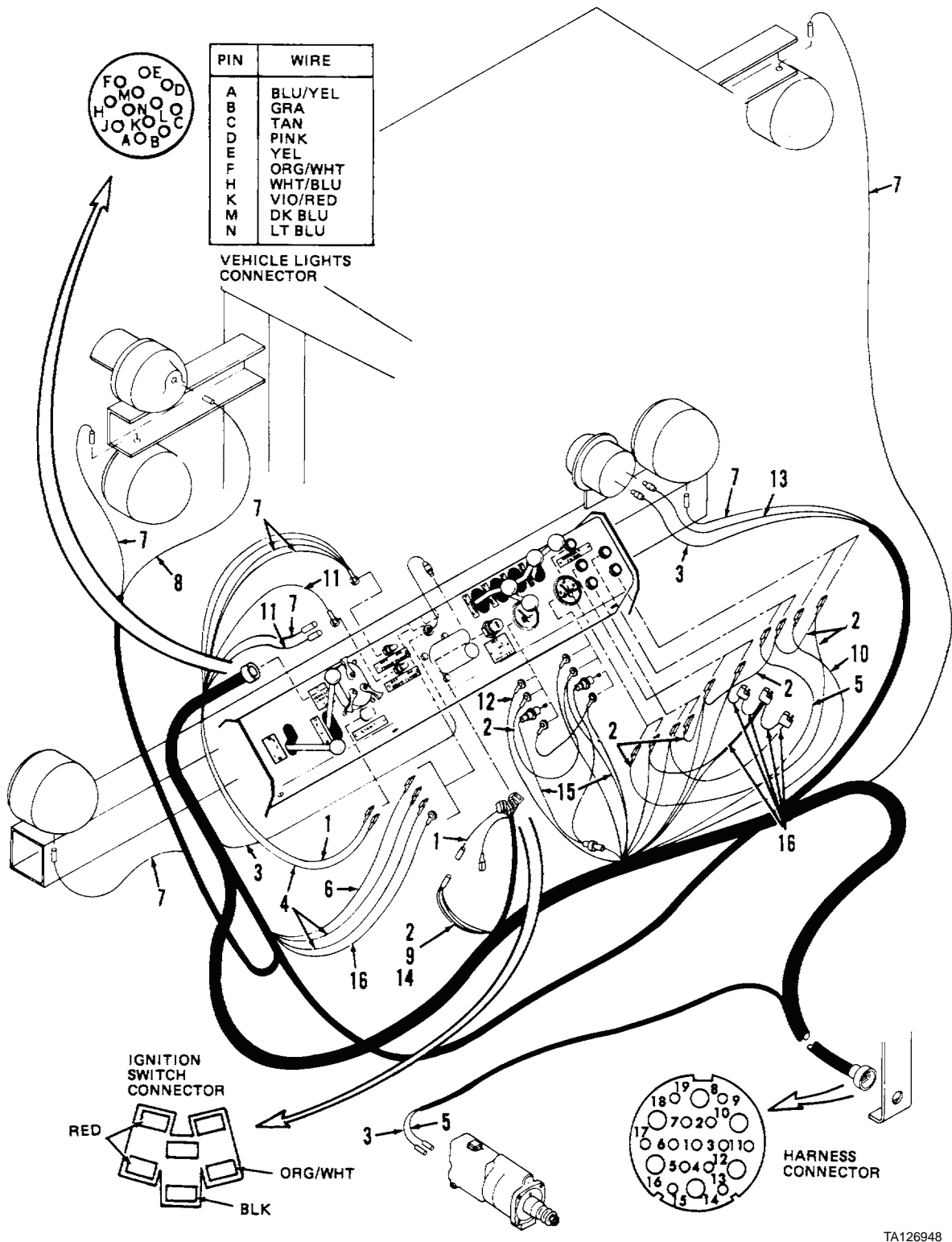

Figure 1. Front Harness Connections.

TA126948

**CLEANING**

1. Wipe wiring harness and wire insulation with a clean, dry rag.

**WARNING**

Solvent cleaning compound MIL-PRF-680 Type III is an environmentally compliant and low toxic material. However, it may be irritating to the eyes and skin. Use protective gloves and goggles. Use in well-ventilated areas. Keep away from open flames and other sources of ignition. Failure to do so may result in injury or death to personnel.

2. Clean electrical terminals and connectors. Use solvent cleaning compound on terminals and connectors only.

**END OF TASK****INSPECTION**

1. Inspect wiring harness and wires. Repair if insulation frayed, or if conductor broken.
2. Disconnect harness connector and inspect. Disconnect and remove as shown. Replace wiring harness if connector is defective (refer to Direct Support Maintenance).

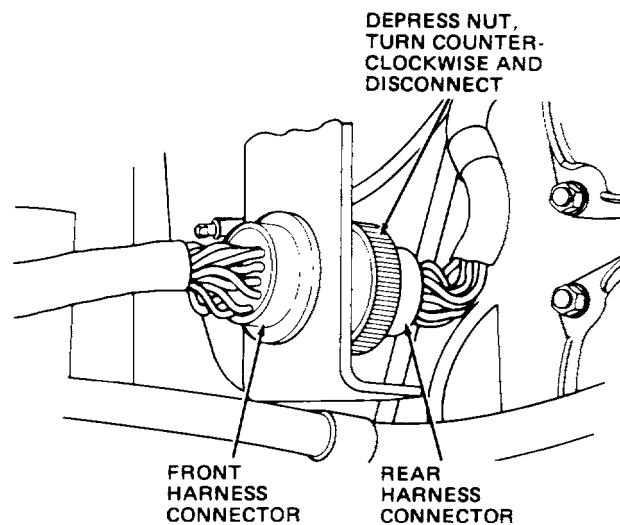

TA126951.1

**Figure 2. Front and Rear Harness Connections.**

3. Inspect other connectors and terminals. Replace bent, damaged, or missing terminals and connectors.

**END OF TASK**

**REPAIR**

1. Wrap insulating tape over frayed insulation of wiring harness and wires.

**NOTE**

Gage of replacement wire must be greater than or equal to gage of defective wire.

2. If defective wire is accessible, cut a length of same gage wire and splice using insulating splice connector. If wire is not accessible, replace wiring harness (notify Direct Support Maintenance).
3. Cut wire close to defective terminal, strip insulation to depth of terminal well, and crimp wire to new terminal or connector.

**END OF TASK****TESTING**

1. Testing front wiring harness consists of starting engine, turning on all lights, depressing service brake pedal, and observing that all lights/indicators/gages are operating. If any abnormal indications are observed, refer to troubleshooting procedures (WP 0005).
2. To perform a continuity test of front wiring harness using an ohmmeter, refer to electrical system wiring schematic located in WP 0306.

**END OF TASK****END OF WORK PACKAGE**

## ORGANIZATIONAL MAINTENANCE INSTRUCTIONS

### REAR WIRING HARNESS MAINTENANCE (MODEL 207)

#### Cleaning, Inspection, Repair, Testing

#### INITIAL SETUP

##### Maintenance Level

Organizational

##### Tools and Special Tools

Tool kit, general mechanic's (Item 15, WP 0309)

Shop equipment, common no. 1 (Item 2, WP 0309)

##### Materials/Parts

Cleaning compound, solvent (Item 10, WP 0310)

##### Materials/Parts - Continued

Rag, wiping (Item 26, WP 0310)

Tape, electrical (Item 35, WP 0310)

##### References

WP 0242

WP 0306

##### Equipment Condition

Battery ground cable disconnected (WP 0133)

#### CLEANING

1. Clean insulation of rear wiring harness wires by wiping with a clean rag.



WARNING



Solvent cleaning compound MIL-PRF-680 Type III is an environmentally compliant and low toxic material. However, it may be irritating to the eyes and skin. Use protective gloves and goggles. Use in well-ventilated areas. Keep away from open flames and other sources of ignition. Failure to do so may result in injury or death to personnel.

2. Clean electrical connectors and terminals with solvent cleaning compound. Dry with clean rags.

#### END OF TASK

## INSPECTION

1. Inspect wire leads of rear wiring harness. Repair if insulation is worn or missing or if conductor is broken (refer to *Repair* in this work package).
2. Inspect rear harness connector. Replace rear wiring harness if connector is damaged.

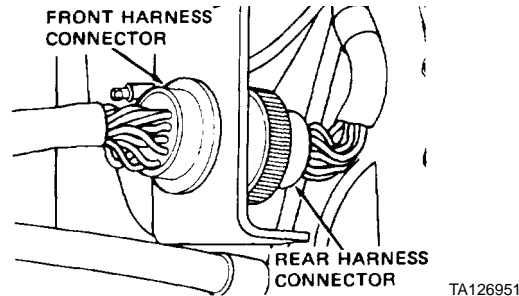

**Figure 1. Front and Rear Harness Connectors.**

3. Inspect all other connectors and terminals. Replace if bent, missing, or damaged (refer to *Repair* in this work package).

## END OF TASK

## REPAIR

1. Repair wire leads of rear wiring harness by wrapping electrical tape over insulation that is worn or missing.

### NOTE

- If defective wire is accessible, cut a length of wire and splice using insulating splice connectors. Gauge of replacement wire must be equal to or greater than gauge of defective wire.
  - If wire is not accessible, replace rear wiring harness (WP 0242).
2. Repair wire lead of rear wiring harness by replacing defective wire.

### NOTE

Cut wire close to defective wire terminal or connector. Strip insulation to depth of terminal well, and crimp new terminal or connector to wire.

3. Repair rear wiring harness by replacing defective terminal or connector.

## END OF TASK

## TESTING

1. Test rear wiring harness by starting engine, turning on all lights, depressing service brake pedal, and observing that all lights/indicators/gages are operating. If any abnormal indications are observed, notify Direct Support Maintenance.
2. To perform a continuity test of rear wiring harness using an ohmmeter, refer to electrical system wiring schematic located in WP 0306.



TESTING - CONTINUED

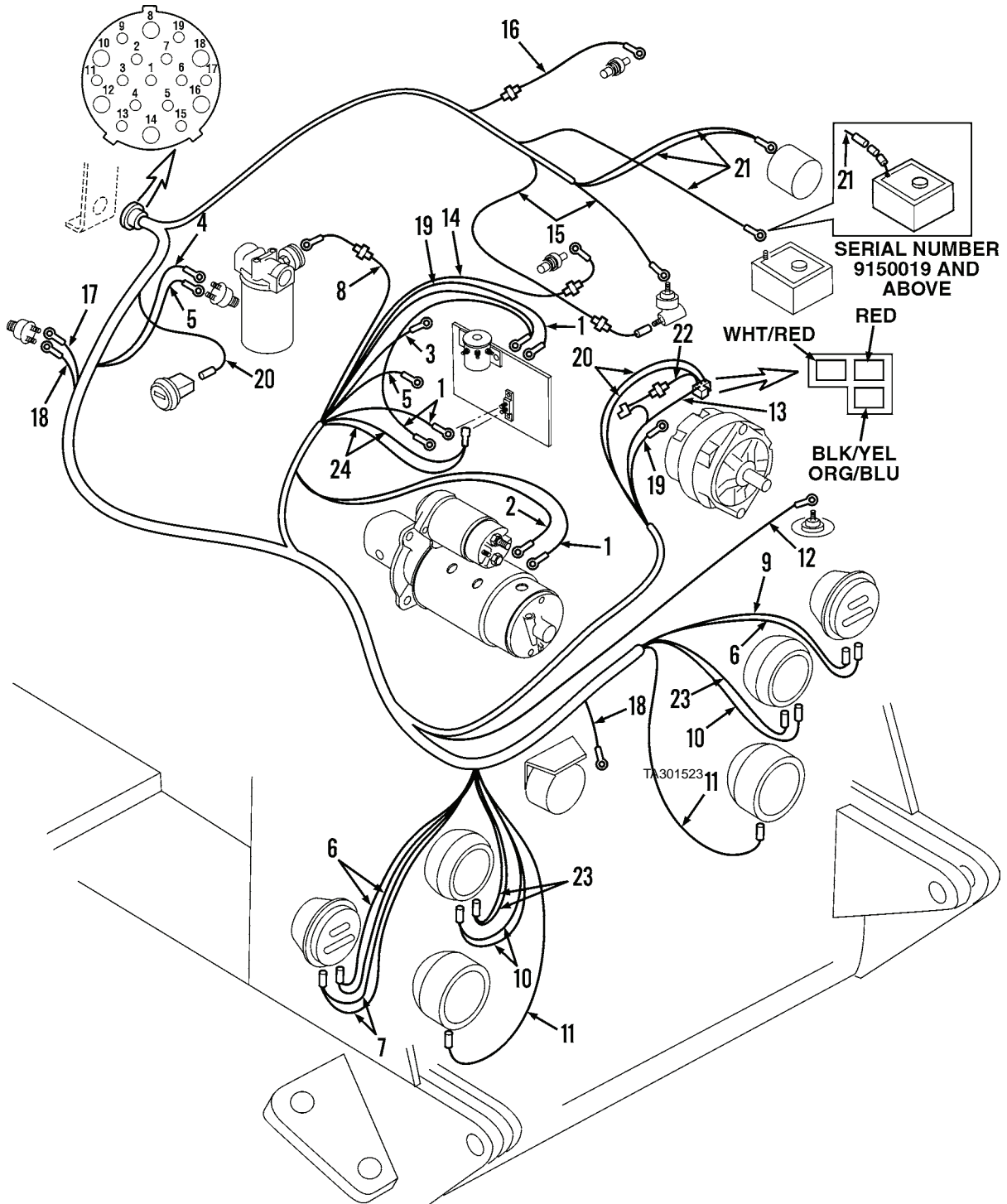

Figure 2. Rear Wiring Harness.

444-1083

END OF TASK  
END OF WORK PACKAGE



---

## ORGANIZATIONAL MAINTENANCE INSTRUCTIONS

### REAR WIRING HARNESS MAINTENANCE (MODEL 4-390)

Cleaning, Inspection, Repair, Testing

---

#### INITIAL SETUP

**Maintenance Level**

Organizational

**Tools and Special Tools**

Tool kit, general mechanic's (Item 15, WP 0309)

Shop equipment, common no. 1 (Item 2, WP 0309)

**Materials/Parts**

Cleaning compound, solvent (Item 10, WP 0310)

Rag, wiping (Item 26, WP 0310)

Tape, electrical (Item 35, WP 0310)

**References**

WP 0005

WP 0140

WP 0306

**Equipment Condition**

Engine OFF

Battery ground cable disconnected (WP 0134)

Left and right side panels removed (WP 0179)

Left and right hood panels removed (WP 0183)

Tow bar lowered to ground and radiator grille opened (WP 0176)

---

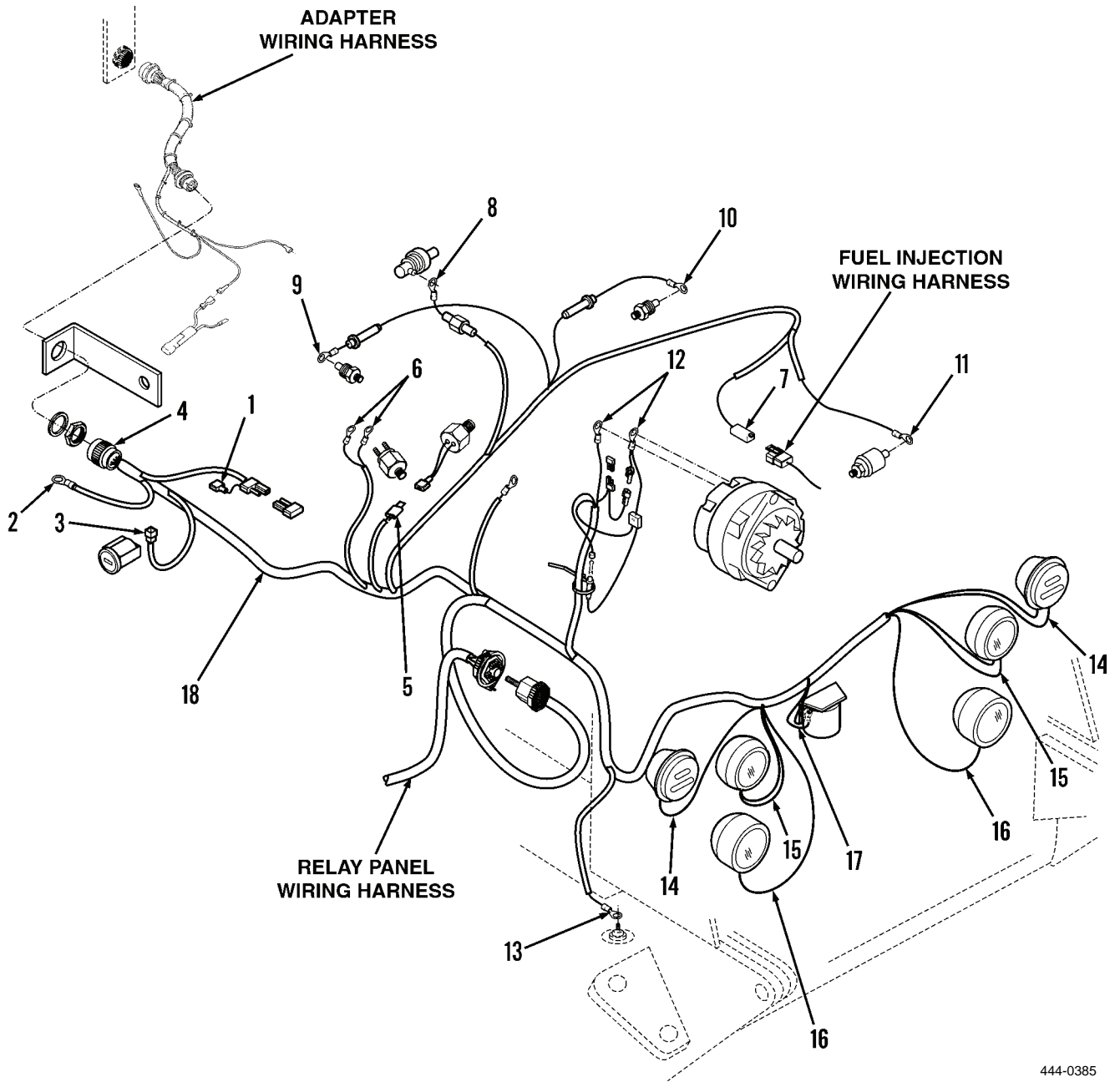

444-0385

Figure 1. Rear Wiring Harness.

**CLEANING**

1. Wipe wiring harness and wire insulation with a clean, dry rag.

**WARNING**

Solvent cleaning compound MIL-PRF-680 Type III is an environmentally compliant and low toxic material. However, it may be irritating to the eyes and skin. Use protective gloves and goggles. Use in well-ventilated areas. Keep away from open flames and other sources of ignition. Failure to do so may result in injury or death to personnel.

2. Use solvent cleaning compound on terminals and connectors only.

**END OF TASK****INSPECTION**

1. Inspect wiring harness and wires. Repair if insulation frayed, or if conductor broken.
2. Disconnect rear wiring harness connector from adapter wiring harness connector and inspect. Replace rear wiring harness if connector is defective (notify Direct Support Maintenance).
3. Disconnect connector of rear wiring harness from relay panel harness (WP 0145). Replace harness if connector is defective (notify Direct Support Maintenance).
4. Inspect other connectors and terminals. Replace bent, damaged, or missing terminals and connectors.

**END OF TASK****REPAIR**

1. Wrap electrical tape over frayed insulation of wiring harness and wires.

**NOTE**

Gage of replacement wire must be greater than or equal to gage of defective wire.

2. If defective wire is accessible, cut a length of same gage wire and splice using insulated splice connector. If wire is not accessible, replace wiring harness (notify Direct Support Maintenance).
3. Cut wire close to defective terminal, strip insulation to depth of terminal well, and crimp wire to new terminal connector.

**END OF TASK****TESTING**

1. Testing rear wiring harness consists of starting engine, turning on all lights, depressing service brake pedal, and observing that all lights/indicators/gages are operating. If any abnormal indications are observed, refer to troubleshooting procedures (WP 0005).
2. To perform a continuity test of rear wiring harness using an ohmmeter, refer to electrical system wiring schematic located in WP 0306.

**END OF TASK****END OF WORK PACKAGE**



---

## ORGANIZATIONAL MAINTENANCE INSTRUCTIONS

### ADAPTER WIRING HARNESS MAINTENANCE (MODEL 4-390)

Cleaning, Inspection, Repair, Testing

---

#### INITIAL SETUP

**Maintenance Level**

Organizational

**Tools and Special Tools**

Tool kit, general mechanic's (Item 15, WP 0309)

Shop equipment, common no. 1 (Item 2, WP 0309)

**Materials/Parts**

Cleaning compound, solvent (Item 10, WP 0310)

Rag, wiping (Item 26, WP 0310)

Tape, electrical (Item 35, WP 0310)

**References**

WP 0005

WP 0138

WP 0306

**Equipment Condition**

Engine OFF

Battery ground cable disconnected (WP 0134)

Left side panel removed (WP 0179)

Left hood panel and left hood support plate removed (WP 0183)

---

**CLEANING**

1. Wipe wiring harness and wire insulation with a clean, dry rag.

**WARNING**

Solvent cleaning compound MIL-PRF-680 Type III is an environmentally compliant and low toxic material. However, it may be irritating to the eyes and skin. Use protective gloves and goggles. Use in well-ventilated areas. Keep away from open flames and other sources of ignition. Failure to do so may result in injury or death to personnel.

2. Clean electrical terminals and connectors. Use solvent cleaning compound on terminals and connectors only.

**END OF TASK****INSPECTION**

1. Inspect wiring harness and wires. Repair if insulation frayed, or if conductor broken.
2. Disconnect connector of adapter wiring harness from front wiring harness. Disconnect connector of rear wiring harness from adapter wiring harness (WP 0138). Replace wiring harness if connector is defective (notify Direct Support Maintenance).
3. Inspect terminals. Replace bent, damaged, or missing terminals.

**END OF TASK****REPAIR**

1. Wrap electrical tape over frayed insulation of wiring harness and wires.

**NOTE**

Gage of replacement wire must be greater than or equal to gage of defective wire.

2. If defective wire is accessible, cut a length of same gage wire and splice using insulating splice connector. If wire is not accessible, replace wiring harness (notify Direct Support Maintenance).
3. Cut wire close to defective terminal, strip insulation to depth of terminal well, and crimp wire to new terminal of connector.

**END OF TASK****TESTING**

1. Testing adapter wiring harness consists of starting engine, turning on all lights, depressing service brake pedal, and observing that all lights/indicators/gages are operating. If any abnormal indications are observed, refer to troubleshooting procedures (WP 0005).
2. To perform a continuity test of adapter wiring harness using an ohmmeter, refer to electrical system wiring schematic located in WP 0306.



TESTING - CONTINUED

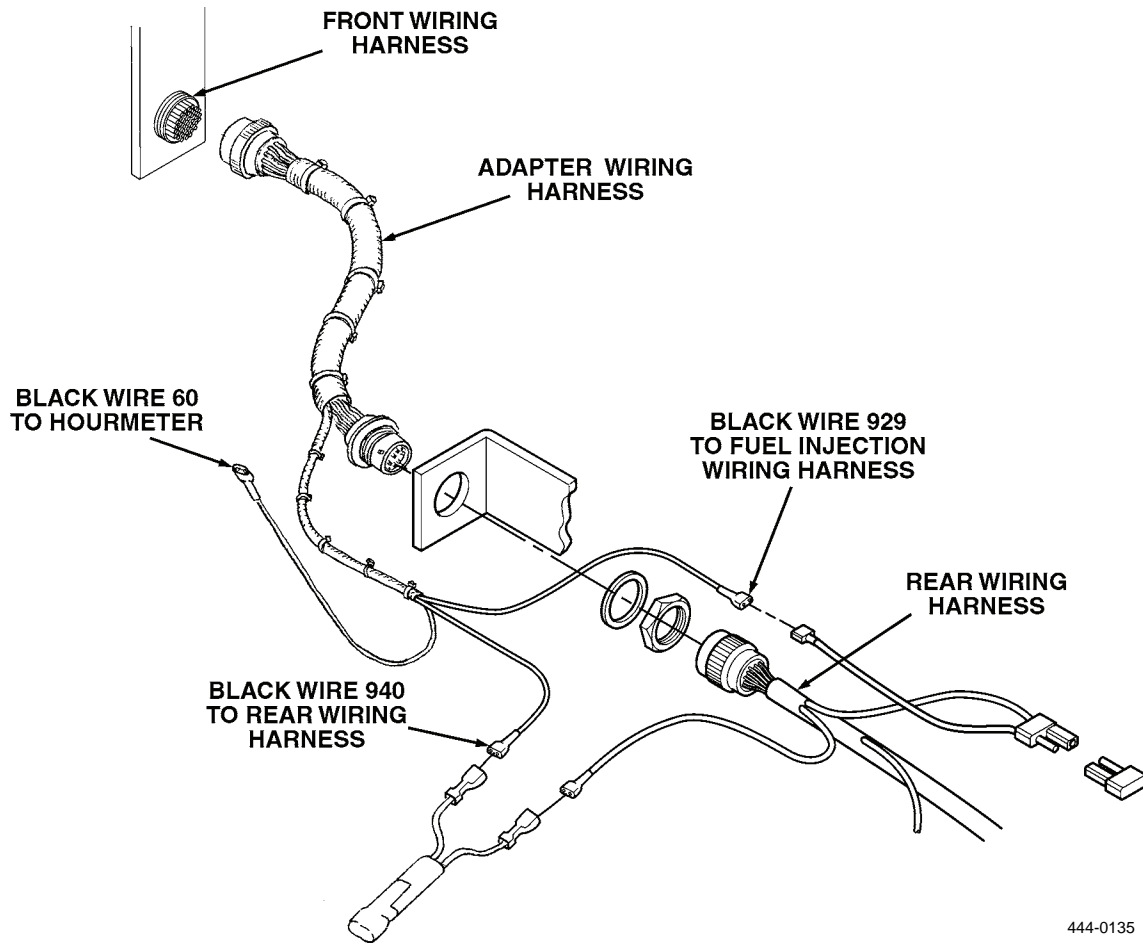

Figure 1. Adapter Wiring Harness.

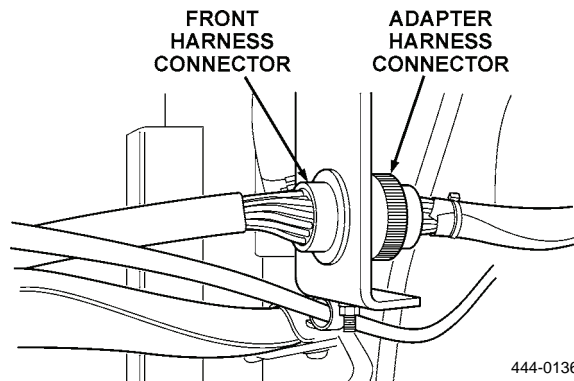

Figure 2. Front and Adapter Harness Connectors.

END OF TASK

END OF WORK PACKAGE



---

## ORGANIZATIONAL MAINTENANCE INSTRUCTIONS

### RELAY PANEL WIRING HARNESS MAINTENANCE (MODEL 4-390)

Cleaning, Inspection, Repair, Testing

---

#### INITIAL SETUP

**Maintenance Level**

Organizational

**Tools and Special Tools**

Tool kit, general mechanic's (Item 15, WP 0309)

Shop equipment, common no. 1 (Item 2, WP 0309)

**Materials/Parts**

Cleaning compound, solvent (Item 10, WP 0310)

Rag, wiping (Item 26, WP 0310)

**Materials/Parts - Continued**

Tape, electrical (Item 35, WP 0310)

**References**

WP 0005

**Equipment Condition**

Engine OFF

Battery ground cable disconnected (WP 0134)

Left side panel removed (WP 0179)

Relay panel cover removed (WP 0098)

---

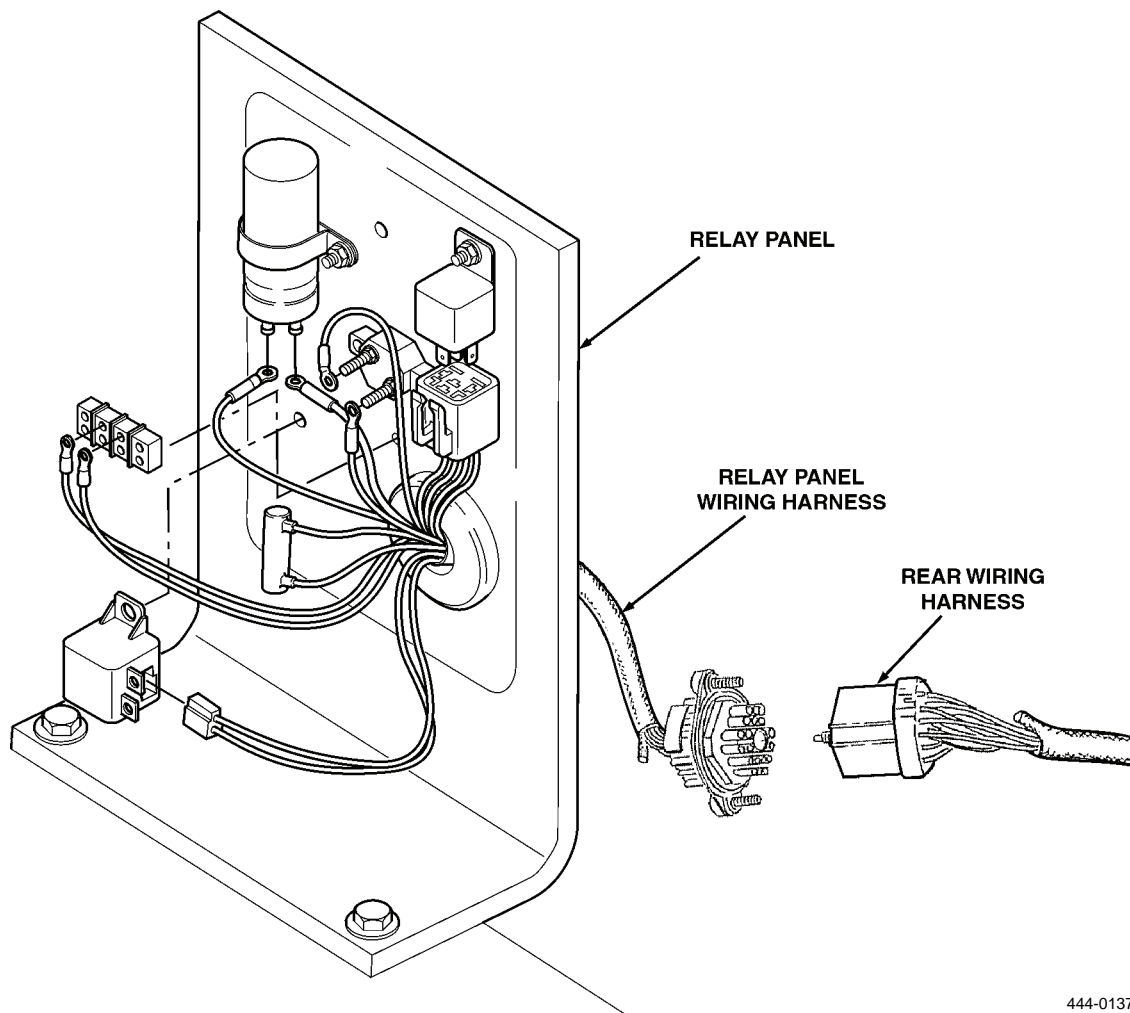

444-0137

Figure 1. Relay Panel Wiring Harness.

## CLEANING

1. Wipe wiring harness and wire insulation with a clean, dry rag.



WARNING



Solvent cleaning compound MIL-PRF-680 Type III is an environmentally compliant and low toxic material. However, it may be irritating to the eyes and skin. Use protective gloves and goggles. Use in well-ventilated areas. Keep away from open flames and other sources of ignition. Failure to do so may result in injury or death to personnel.

2. Clean electrical terminals and connectors. Use solvent cleaning compound on terminals and connectors only.

## END OF TASK

**INSPECTION**

1. Inspect wiring harness and wires. Repair if insulation frayed, or if conductor broken.
2. Disconnect connector of rear wiring harness from relay panel harness by turning screw at center of rear wiring harness connector. Replace harness if connector is defective (notify Direct Support Maintenance).
3. Inspect terminals. Replace bent, damaged, or missing terminals.

**END OF TASK****REPAIR**

1. Wrap electrical tape over frayed insulation wiring harness and wires.

**NOTE**

Gage of replacement wire must be greater than or equal to gage of defective wire.

2. If defective wire is accessible, cut a length of same gage wire and splice using insulating splice connector. If wire is not accessible, replace wiring harness (notify Direct Support Maintenance).
3. Cut wire close to defective terminal, strip insulation to depth of terminal well, and crimp wire to new terminal or connector.

**END OF TASK****TESTING**

1. Testing relay panel wiring harness consists of starting engine and allowing engine to run. If any abnormal indications are observed, refer to troubleshooting procedures (WP 0005).
2. Use an ohmmeter to perform a continuity test of relay panel wiring harness as necessary.

**END OF TASK****END OF WORK PACKAGE**



---

## ORGANIZATIONAL MAINTENANCE INSTRUCTIONS

### FUEL INJECTION WIRING HARNESS MAINTENANCE (MODEL 4-390)

Cleaning, Inspection, Repair, Testing

---

#### INITIAL SETUP

**Maintenance Level**

Organizational

**Tools and Special Tools**

Tool kit, general mechanic's (Item 15, WP 0309)

Shop equipment, common no. 1 (Item 2, WP 0309)

**Materials/Parts**

Cleaning compound, solvent (Item 10, WP 0310)

**Materials/Parts - Continued**

Rag, wiping (Item 26, WP 0310)

**References**

WP 0005

**Equipment Condition**

Engine OFF

Battery ground cable disconnected (WP 0134)

Left and right side panels removed (WP 0179)

Relay panel cover removed (WP 0098)

---

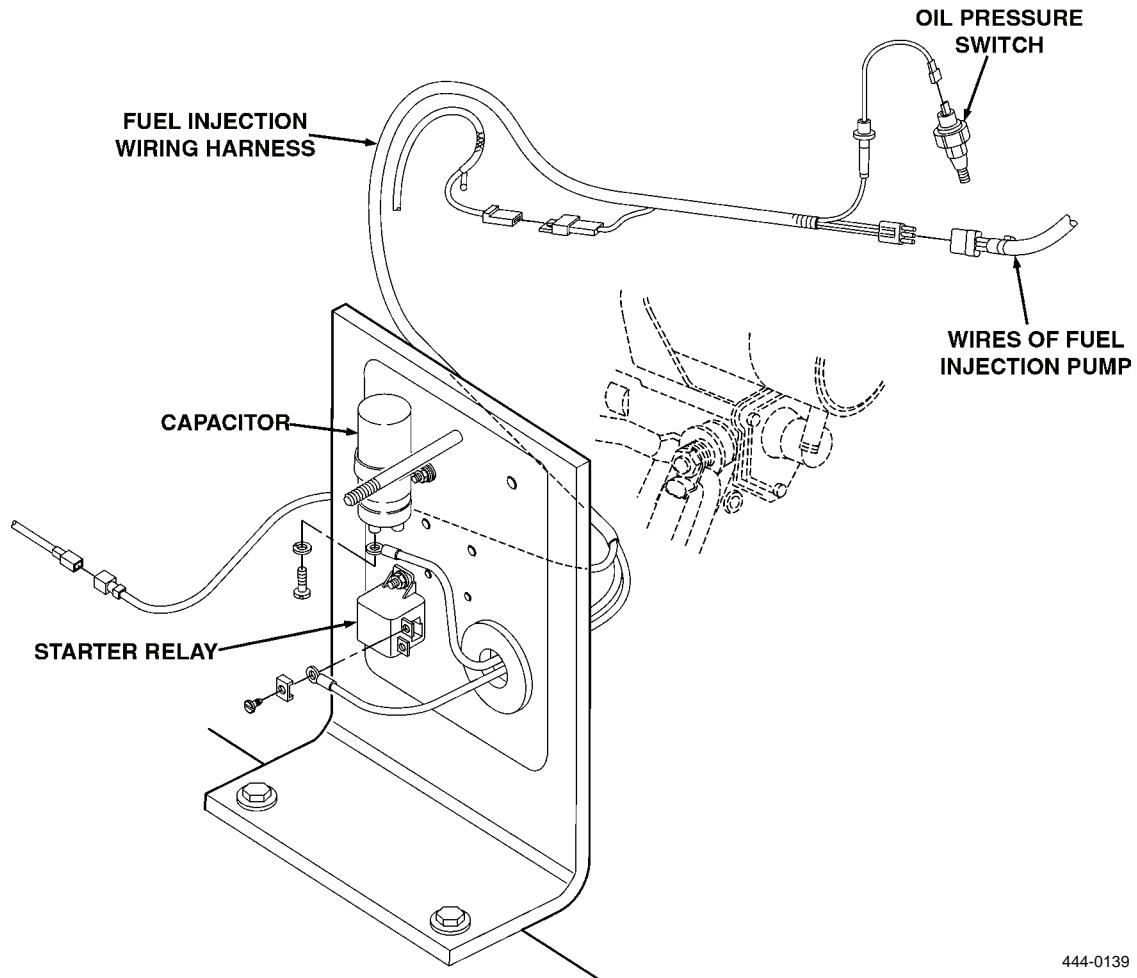

444-0139

Figure 1. Fuel Injection Wiring Harness.

**CLEANING**

1. Wipe wiring harness and wire insulation with a clean, dry rag.



**WARNING**



Solvent cleaning compound MIL-PRF-680 Type III is an environmentally compliant and low toxic material. However, it may be irritating to the eyes and skin. Use protective gloves and goggles. Use in well-ventilated areas. Keep away from open flames and other sources of ignition. Failure to do so may result in injury or death to personnel.

2. Clean electrical terminals and connectors. Use solvent cleaning compound on terminals and connectors only.

**END OF TASK**



**INSPECTION**

1. Inspect wiring harness and wires. Repair if insulation frayed, or if conductor broken.
2. Inspect terminals. Replace bent, damaged, or missing terminals and connectors.

**END OF TASK****REPAIR**

1. Wrap insulating tape over frayed insulation of wiring harness and wires.

**NOTE**

Gage of replacement wire must be greater than or equal to gage of defective wire.

2. If defective wire is accessible, cut a length of same gage wire and splice using insulating splice connector. If wire is not accessible, replace wiring harness (notify Direct Support Maintenance).
3. Cut wire close to defective terminal, strip insulation to depth of terminal well, and crimp wire to new terminal or connector.

**END OF TASK****TESTING**

1. Testing fuel injection wiring harness consists of starting engine and allowing engine to run. If any abnormal indications are observed, refer to troubleshooting procedures (WP 0005).
2. Use an ohmmeter to perform a continuity test of fuel injection wiring harness as necessary.

**END OF TASK****END OF WORK PACKAGE**



---

## ORGANIZATIONAL MAINTENANCE INSTRUCTIONS

### CABLE WIRING HARNESS MAINTENANCE (MODEL 4-390)

Cleaning, Inspection, Repair, Testing

---

#### INITIAL SETUP

**Maintenance Level**

Organizational

**Tools and Special Tools**

Tool kit, general mechanic's (Item 15, WP 0309)

Shop equipment, common no. 1 (Item 2, WP 0309)

**Materials/Parts**

Cleaning compound, solvent (Item 10, WP 0310)

Rag, wiping (Item 26, WP 0310)

**Materials/Parts - Continued**

Tape, electrical (Item 35, WP 0310)

**References**

WP 0005

**Equipment Condition**

Engine OFF

Battery ground cable disconnected (WP 0134)

Left side panel removed (WP 0179)

Relay panel cover removed (WP 0098)

---

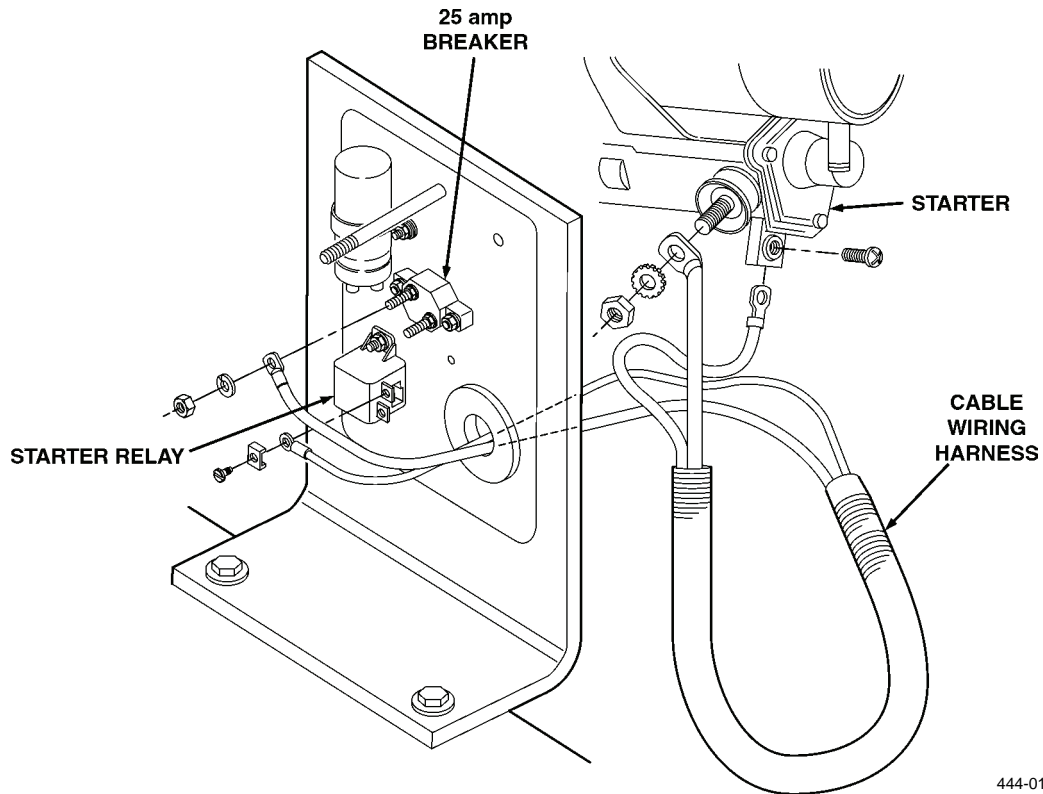

444-0140

Figure 1. Cable Wiring Harness.

**CLEANING**

1. Wipe wiring harness and cable insulation with a clean, dry rag.

**WARNING**

Solvent cleaning compound MIL-PRF-680 Type III is an environmentally compliant and low toxic material. However, it may be irritating to the eyes and skin. Use protective gloves and goggles. Use in well-ventilated areas. Keep away from open flames and other sources of ignition. Failure to do so may result in injury or death to personnel.

2. Clean electrical terminals. Use solvent cleaning compound on terminals only.

**END OF TASK****INSPECTION**

1. Inspect wiring harness. Repair if insulation frayed.
2. Inspect terminals. Replace bent, damaged, or missing terminals.

**END OF TASK**

**REPAIR**

1. Wrap electrical tape over frayed insulation of wiring harness and cables.
2. Replace wiring harness and cables. If cable conductor is damaged, replace wiring harness (notify Direct Support Maintenance).
3. Replace terminals. Cut cable close to defective terminal, strip insulation to depth of terminal well, and crimp new terminal to cable conductor.

**END OF TASK****TESTING**

1. Testing of cable wiring harness consists of starting engine and allowing engine to run. If any abnormal indications are observed, refer to troubleshooting procedures (WP 0005).
2. Use an ohmmeter to perform a continuity test of cable wiring harness as necessary.

**END OF TASK****END OF WORK PACKAGE**



---

# ORGANIZATIONAL MAINTENANCE INSTRUCTIONS

## DRAINING AND FILLING TRANSMISSION

### Draining, Filling

---

#### INITIAL SETUP

**Maintenance Level**

Organizational

**Tools and Special Tools**

Tool kit, general mechanic's (Item 15, WP 0309)

Shop equipment, common no. 1 (Item 2, WP 0309)

Container, 7-gal. capacity

**Materials/Parts**

Lubricating oil, OE/HDO-10 (Item 20, WP 0310)

Rag, wiping (Item 26, WP 0310)

**References**

LO 10-3930-638-12

**References - Continued**

WP 0144

WP 0145

WP 0146

**Equipment Condition**

Engine operated for 15 minutes immediately prior to draining oil

Engine OFF

Vehicle parked on level surface

Parking brake applied

Left and right side panels removed (WP 0179)

---

**NOTE**

Position 7 gal. (27 L) container under drain plug before removing.

**DRAINING**

1. Remove transmission oil drain plug from transmission (Figure 1).
2. Drain transmission oil.
3. Remove and clean screen assembly (WP 0144).
4. Remove and clean air breather (WP 0145).
5. Remove and discard oil filter (WP 0146).

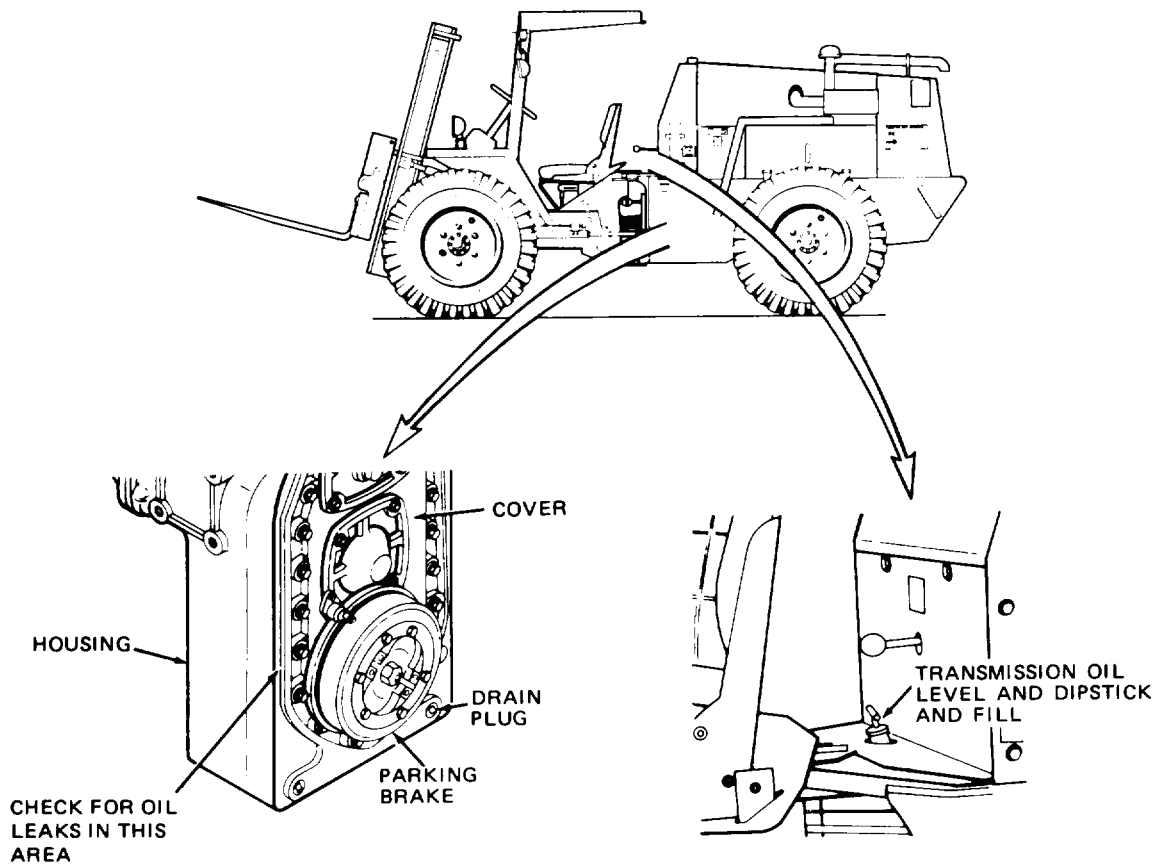

TA126955

**Figure 1. Draining and Filling Transmission.**

**END OF TASK**



**FILLING**

1. Install transmission oil drain plug on transmission (Figure 1).
2. Install new oil filter (WP 0146).
3. Install air breather (WP 0145).
4. Install screen assembly (WP 0144).
5. Fill transmission to dipstick LOW mark (LO 10-3930-638-12).
6. Start engine and let idle.
7. Check transmission oil level with engine at idle speed.
8. Add oil to reach low mark if necessary. When oil is hot, recheck oil level. Add oil to reach FULL mark on dipstick, if necessary.

**END OF TASK****END OF WORK PACKAGE**



---

# ORGANIZATIONAL MAINTENANCE INSTRUCTIONS

## TRANSMISSION SCREEN REPLACEMENT

Removal, Cleaning, Installation

---

### INITIAL SETUP

#### Maintenance Level

Organizational

#### Tools and Special Tools

Tool kit, general mechanic's (Item 15, WP 0309)

Shop equipment, common no. 1 (Item 2, WP 0309)

#### Materials/Parts

Cleaning compound, solvent (Item 10, WP 0310)

Rag, wiping (Item 26, WP 0310)

Gasket

#### Equipment Conditions

Transmission oil drained (WP 0143)

---

**REMOVAL**

1. Remove transmission screen (Figure 1).
2. Remove and discard gasket.

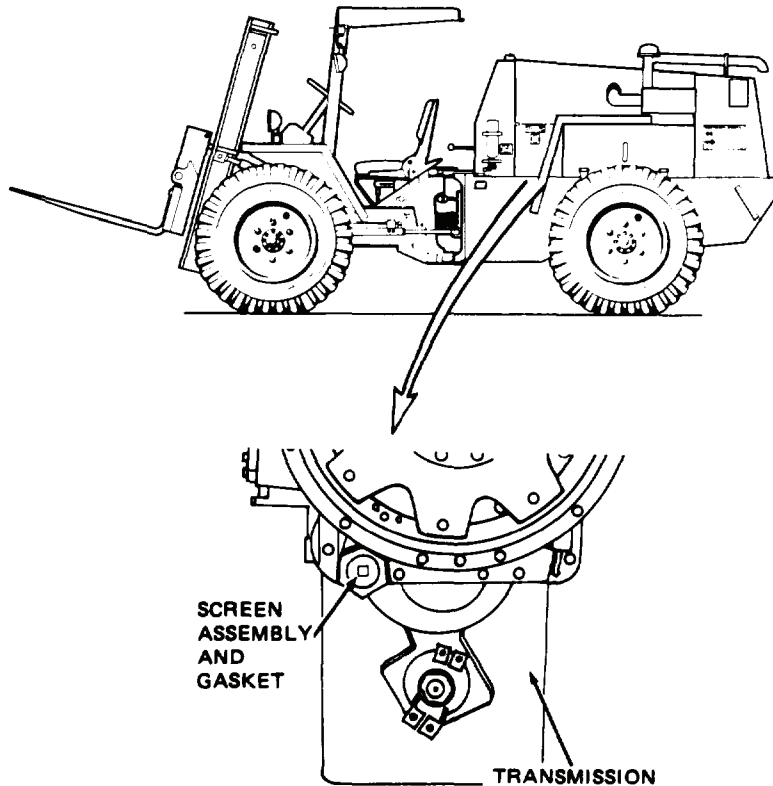

TA126956

Figure 1. Transmission Screen.

**END OF TASK****CLEANING****WARNING**

Solvent cleaning compound MIL-PRF-680 Type III is an environmentally compliant and low toxic material. However, it may be irritating to the eyes and skin. Use protective gloves and goggles. Use in well-ventilated areas. Keep away from open flames and other sources of ignition. Failure to do so may result in injury or death to personnel.

Use solvent cleaning compound to clean transmission screen.

**END OF TASK**

**INSPECTION**

Inspect transmission screen. Replace if torn, broken, or dented.

**END OF TASK****INSTALLATION**

1. Position new gasket on transmission (Figure 1).
2. Install transmission screen. Tighten to 10 to 15 lb-ft (14 to 20 Nm).
3. Fill transmission with oil (WP 0143).

**END OF TASK****END OF WORK PACKAGE**



---

## ORGANIZATIONAL MAINTENANCE INSTRUCTIONS

### TRANSMISSION AIR BREATHER REPLACEMENT

Removal, Cleaning, Inspection, Installation

---

#### INITIAL SETUP

##### Maintenance Level

Organizational

##### Tools and Special Tools

Tool kit, general mechanic's (Item 15, WP 0309)

Shop equipment, common no. 1 (Item 2, WP 0309)

##### Materials/Parts

Cleaning compound, solvent (Item 10, WP 0310)

Rag, wiping (Item 26, WP 0310)

##### Equipment Condition

Engine OFF

Left side panel removed (WP 0179)

---

**REMOVAL**

Remove air breather from top of transmission torque converter housing (Figure 1).

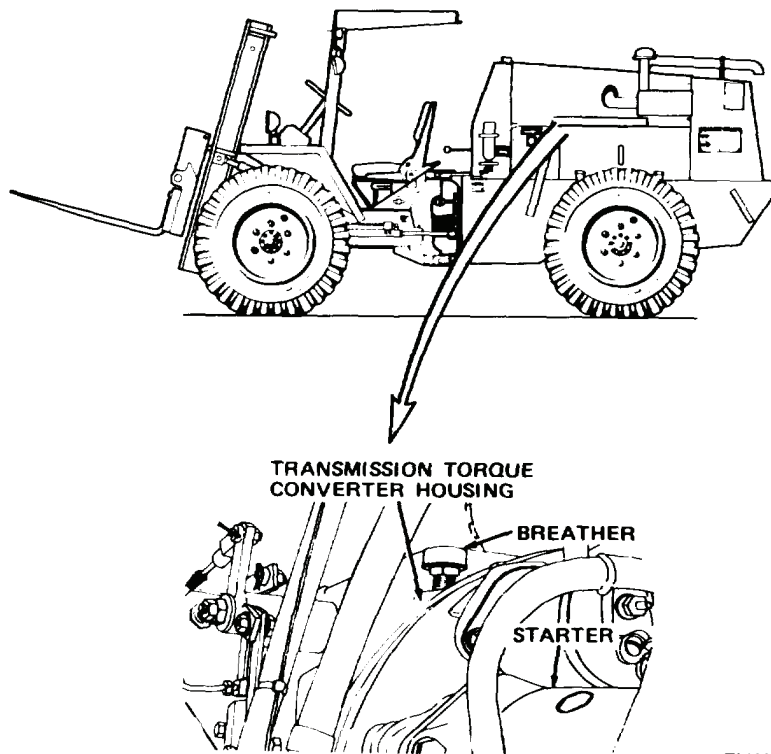

TA126957

Figure 1. Transmission Air Breather.

**END OF TASK****CLEANING****WARNING**

Solvent cleaning compound MIL-PRF-680 Type III is an environmentally compliant and low toxic material. However, it may be irritating to the eyes and skin. Use protective gloves and goggles. Use in well-ventilated areas. Keep away from open flames and other sources of ignition. Failure to do so may result in injury or death to personnel.

Use solvent cleaning compound to clean air breather.

**END OF TASK**



**INSPECTION**

Inspect air breather. Replace if damaged or clogged.

**END OF TASK****INSTALLATION**

Install air breather on top of transmission torque converter housing (Figure 1).

**END OF TASK****END OF WORK PACKAGE**



---

# ORGANIZATIONAL MAINTENANCE INSTRUCTIONS

## TRANSMISSION OIL FILTER REPLACEMENT

### Removal, Installation

---

#### INITIAL SETUP

**Maintenance Level**

Organizational

**Materials/Parts**

Lubricating oil, OE/HDO-10 (Item 20, WP 0310)

**Tools and Special Tools**

Tool kit, general mechanic's (Item 15, WP 0309)

Shop equipment, common no. 1 (Item 2, WP 0309)

**Equipment Conditions**Transmission oil drained (WP 0143)

---

#### REMOVAL

Use clamp-type wrench to remove and discard oil filter (Figure 1).

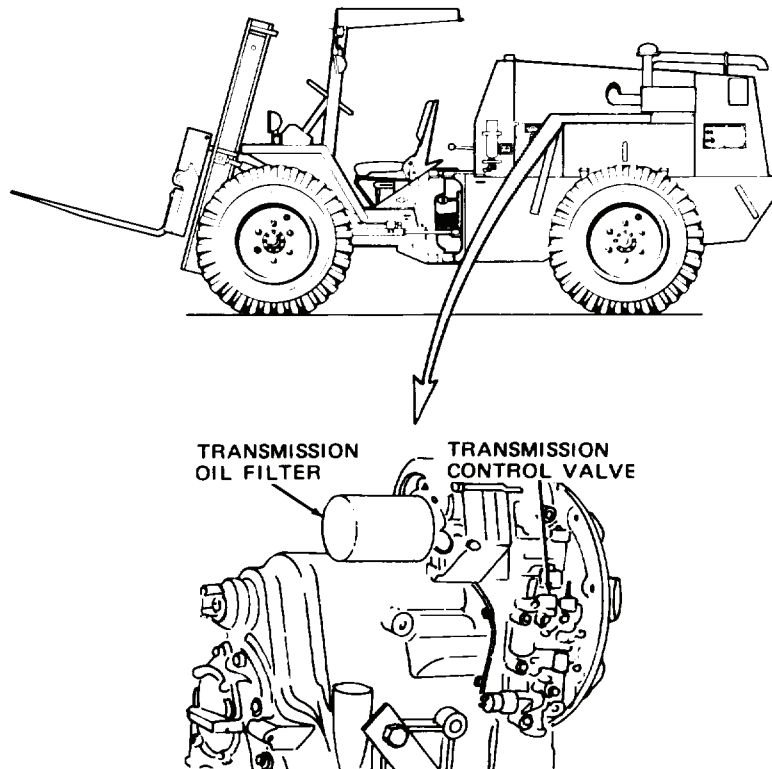

TA127502

Figure 1. Transmission Oil Filter.

#### END OF TASK

**INSTALLATION**

1. Use clean lubricating oil to coat oil filter gasket
2. Install until gasket contacts base. Then, tighten oil filter one-half to three-quarters of a turn to obtain proper seal.
3. Fill transmission with lubricating oil (WP 0143).

**END OF TASK****END OF WORK PACKAGE**

---

# ORGANIZATIONAL MAINTENANCE INSTRUCTIONS

## TRANSMISSION INSPECTION

### Inspection

---

#### INITIAL SETUP

**Maintenance Level**

Organizational

**Tools and Special Tools**

Tool kit, general mechanic's (Item 15, WP 0309)

**Materials/Parts**

Rag, wiping (Item 26, WP 0310)

**References**

WP 0144

WP 0145

WP 0148

**Equipment Condition**

Engine OFF

Vehicle parked on level surface

Parking brake applied.

Left and right side panels removed (WP 0179)

---

**INSPECTION**

1. Inspect drain plug for oil leakage (Figure 1). Tighten if oil leakage is observed.
2. Inspect transmission cover for oil leakage between cover and housing. Notify Direct Support Maintenance if oil leakage observed.

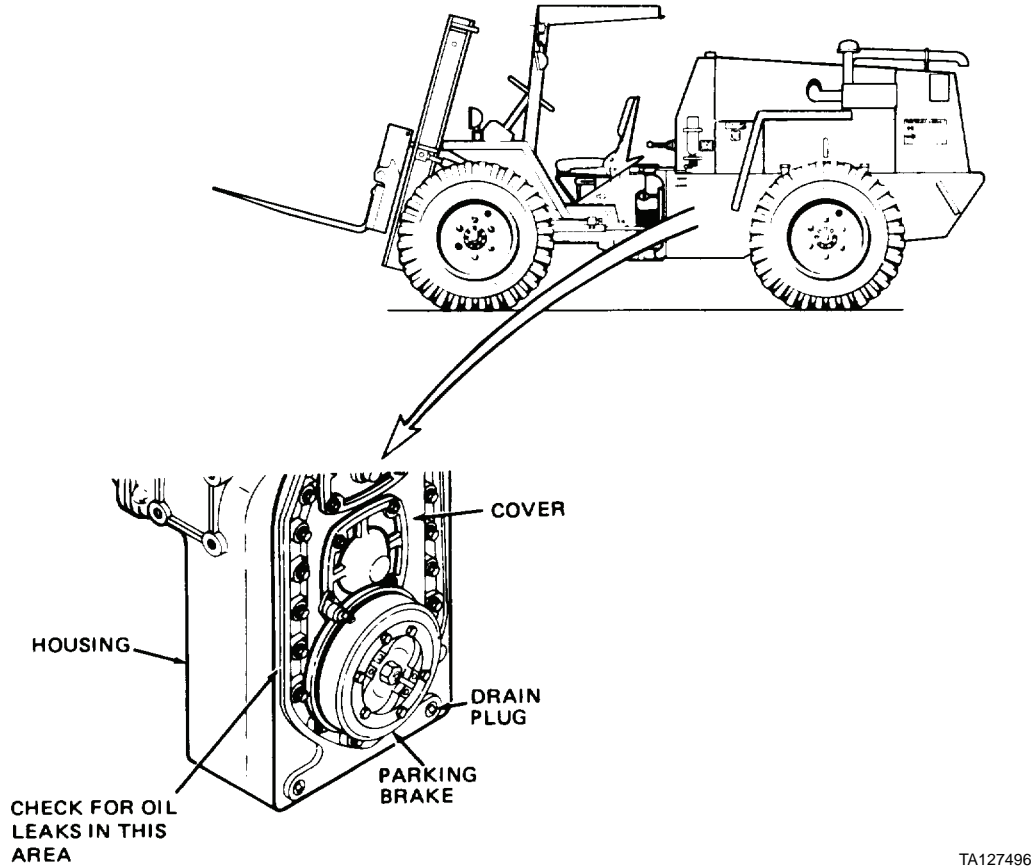
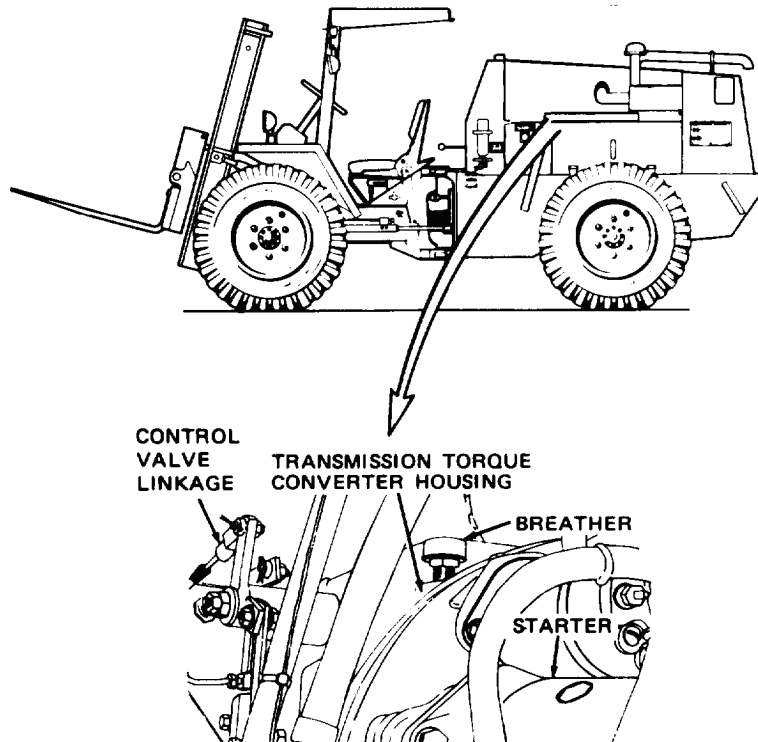

Figure 1. Drain Plug and Cover Inspection.

TA127496

**INSPECTION - CONTINUED**

3. Inspect breather for dirty condition and oil leakage (Figure 2). Clean if dirty (WP 0145); tighten if oil leakage is observed.
4. Inspect torque converter housing for oil leakage between converter housing and transmission housing. Notify Direct Support Maintenance if oil leakage is observed.
5. Inspect control valve linkage for missing or loose parts. While an assistant moves transmission levers through their entire range, ensure spools move. If parts are missing or loose or if spools do not move, repair (WP 0148).



TA127497

**Figure 2. Breather, Housing, and Linkage Inspection.**

**INSPECTION - CONTINUED**

6. Inspect control valve for oil leakage between control valve and mounting surface and at top of control valve (Figure 3). Notify Direct Support Maintenance if oil leakage is observed.
7. Inspect oil filter for oil leakage at base. Tighten oil filter if leakage is observed.
8. Inspect charging pump for oil leakage between pump and mounting surface. If oil leakage is observed, tighten pump mounting bolts; if bolts are tight, notify Direct Support Maintenance.

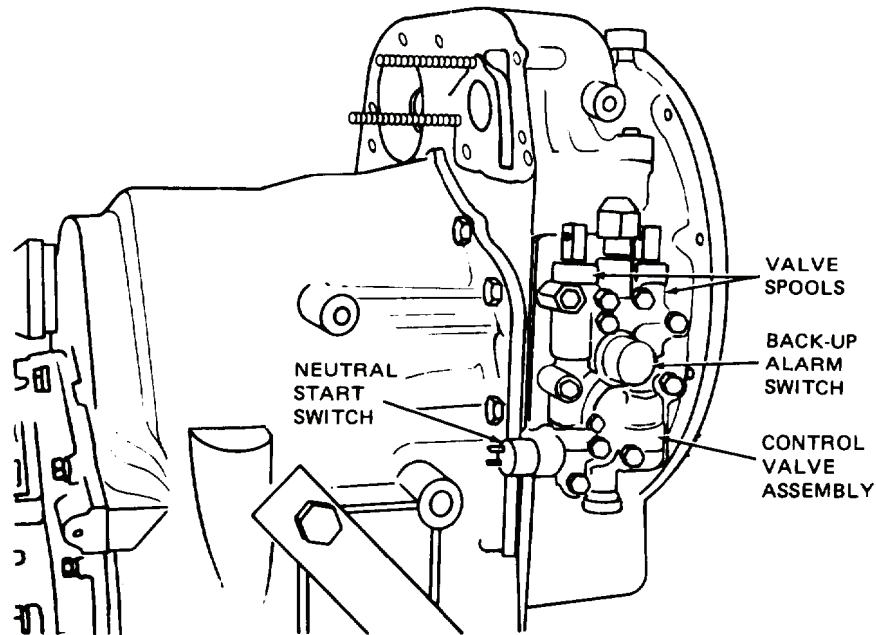

TA127498

**Figure 3. Control Valve Inspection.**



**INSPECTION - CONTINUED**

9. Inspect screen assembly for oil leakage (Figure 4). Tighten screen assembly to 10 to 15 lb-ft (15 to 20 Nm) if oil leakage is observed. If screen assembly is tight, replace gasket (WP 0144).
10. Inspect yoke area for oil leakage. Notify Direct Support Maintenance if oil leakage is observed.

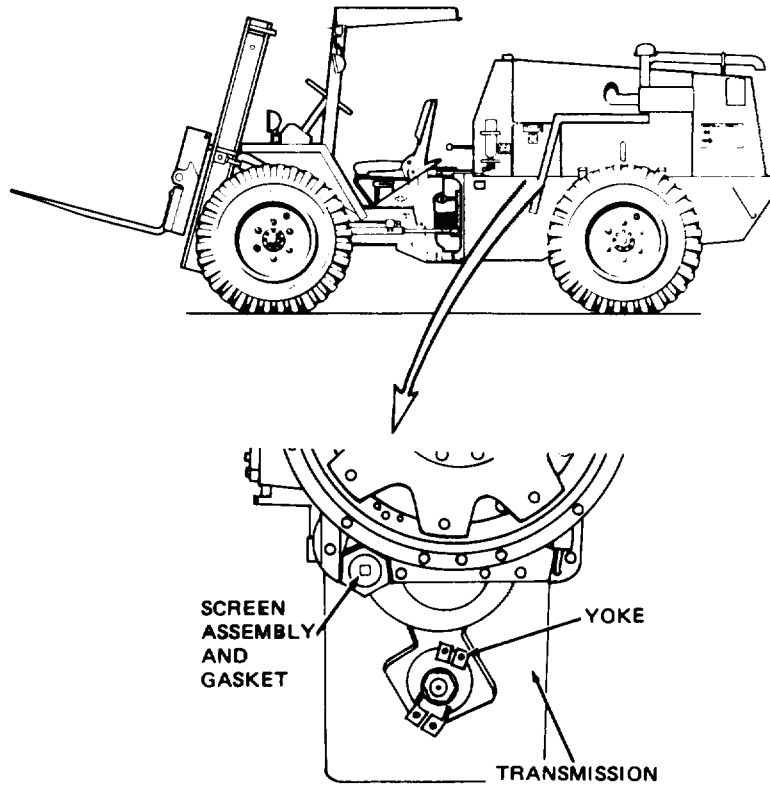

TA127503

**Figure 4. Screen and Yoke Inspection.****END OF TASK****END OF WORK PACKAGE**



---

# ORGANIZATIONAL MAINTENANCE INSTRUCTIONS

## TRANSMISSION LINKAGE CONTROLS MAINTENANCE

Inspection, Removal, Cleaning, Inspection/Repair, Installation/Replacement, Adjustment

---

### INITIAL SETUP

#### Maintenance Level

Organizational

#### Tools and Special Tools

Tool kit, general mechanic's (Item 15, WP 0309)

Shop equipment, common no. 1 (Item 2, WP 0309)

#### Materials/Parts

Cleaning compound, solvent (Item 10, WP 0310)

Diesel fuel, arctic (Item 14, WP 0310)

Diesel fuel, DF-2 (Item 15, WP 0310)

Rag, wiping (Item 26, WP 0310)

#### Materials/Parts - Continued

Strap, tiedown (Item 32, WP 0310)

Tag, marker (Item 33, WP 0310)

Cotter pin (3)

Lockwasher (11)

#### Equipment Condition

Engine OFF

Parking brake applied

Left side panel removed (WP 0179)

Left hood support plate removed (WP 0182 and  
WP 0183)

Noise baffle mat removed (WP 0187)

Chassis guard removed (WP 0188)

---

### INSPECTION

1. Inspect speed control lever for loose or missing parts. Tighten loose parts; replace missing parts.
2. Inspect direction control lever for loose or missing parts. Tighten loose parts; replace missing parts.
3. Inspect linkage (at control valve) for loose or missing parts. Tighten loose parts; replace missing parts.
4. Ensure when levers are moved, linkage causes control valve spools to move.
5. If necessary, disassemble and inspect parts if control valve spools do not move.

### END OF TASK

---

**REMOVAL**

1. Remove nut (Figure 1, Item 1) and lockwasher (Figure 1, Item 2) from stud of ball joint (Figure 1, Item 3). Discard lockwasher.
2. Detach ball joint (Figure 1, Item 3) and remove from cable (Figure 1, Item 53).
3. Remove nut (Figure 1, Item 4) from ball joint (Figure 1, Item 3).
4. Remove nut (Figure 1, Item 5) from speed control lever (Figure 1, Item 15).
5. Remove two washers (Figure 1, Items 6 and 13) from speed control lever (Figure 1, Item 15).
6. Remove nut (Figure 1, Item 7) and washer (Figure 1, Item 9) from support bracket (Figure 1, Item 8).
7. Remove support bracket (Figure 1, Item 8) from speed control lever (Figure 1, Item 15).
8. Remove spring (Figure 1, Item 10) and spacer (Figure 1, Item 11) from vehicle.
9. Remove capscrew (Figure 1, Item 12) from vehicle.
10. Remove nut (Figure 1, Item 14) from speed control lever (Figure 1, Item 15).
11. Remove speed control lever (Figure 1, Item 15) from vehicle.
12. Remove control lever knob (Figure 1, Item 16) from speed control lever (Figure 1, Item 15).
13. Remove cotter pin (Figure 1, Item 17) from clevis pin (Figure 1, Item 18). Discard cotter pin.
14. Remove clevis pin (Figure 1, Item 18) from clevis (Figure 1, Item 19).
15. Disconnect clevis (Figure 1, Item 19) and remove from cable (Figure 1, Item 54).
16. Remove nut (Figure 1, Item 20) from capscrew (Figure 1, Item 21).
17. Remove capscrew (Figure 1, Item 21) and two washers (Figure 1, Item 22) from vehicle.
18. Remove control lever knob (Figure 1, Item 23) from direction control lever (Figure 1, Item 24).
19. Remove direction control lever (Figure 1, Item 24) from vehicle.
20. Remove two nuts (Figure 1, Item 25) from cables (Figure 1, Items 53 and 54).
21. Loosen nuts on cables (Figure 1, Items 53 and 54) and detach from bracket.
22. Tag cables (Figure 1, Items 53 and 54) in engine compartment for proper installation.

REMOVAL - CONTINUED

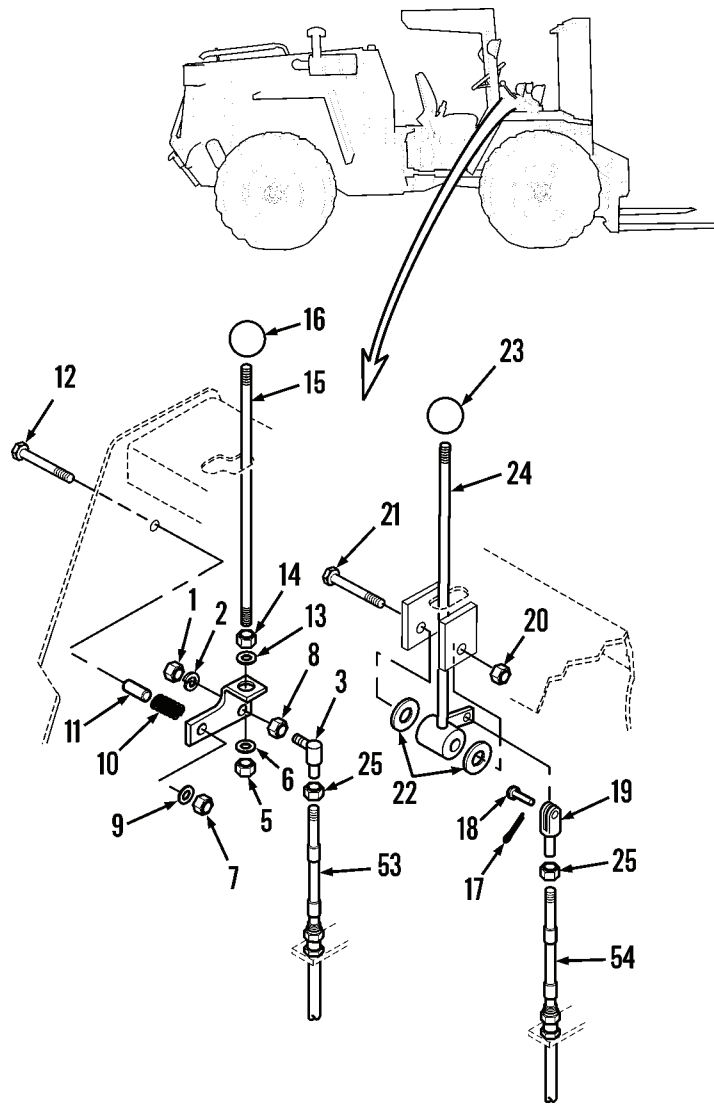

444-1090

Figure 1. Transmission Linkage Controls.

---

**REMOVAL - CONTINUED**

23. Remove four nuts (Figure 2, Item 26), lockwashers (Figure 2, Item 27), washers (Figure 2, Item 28), and spacers (29) from capscrews (Figure 1, Item 30). Discard lockwashers.
24. Remove four capscrews (Figure 2, Item 30) from two links (Figure 2, Item 31).
25. At outer bellcrank (Figure 2, Item 38) and inner bellcrank (Figure 2, Item 39), remove two links (Figure 2, Item 31), cotter pins (32), clevis pins (Figure 2, Item 33), clevises (Figure 2, Item 34), and nuts (Figure 2, Item 35). Discard cotter pins.
26. At transmission, remove two nuts (Figure 2, Item 36) and washer (Figure 2, Item 37) from stud (Figure 2, Item 41).
27. Remove outer bellcrank (Figure 2, Item 38), inner bellcrank (Figure 2, Item 39), spacer (Figure 2, Item 40), stud (Figure 2, Item 41), two capscrews (Figure 2, Item 42), lockwashers (Figure 2, Item 43), and cable bracket (Figure 2, Item 44). Discard lockwashers.
28. From operator's compartment, under floor, remove four nuts (Figure 2, Item 45), lockwashers (Figure 2, Item 46), three spacers (Figure 2, Item 47), four capscrews (Figure 2, Item 48), washer (Figure 2, Item 55), clamp (Figure 2, Item 49), two cable hold-down plates (Figure 2, Item 50), cable clamps (Figure 2, Item 51), tiedown straps (Figure 2, Item 52), and cables (Figure 2, Items 53 and 54) from vehicle. Discard lockwashers and tiedown straps.

REMOVAL - CONTINUED

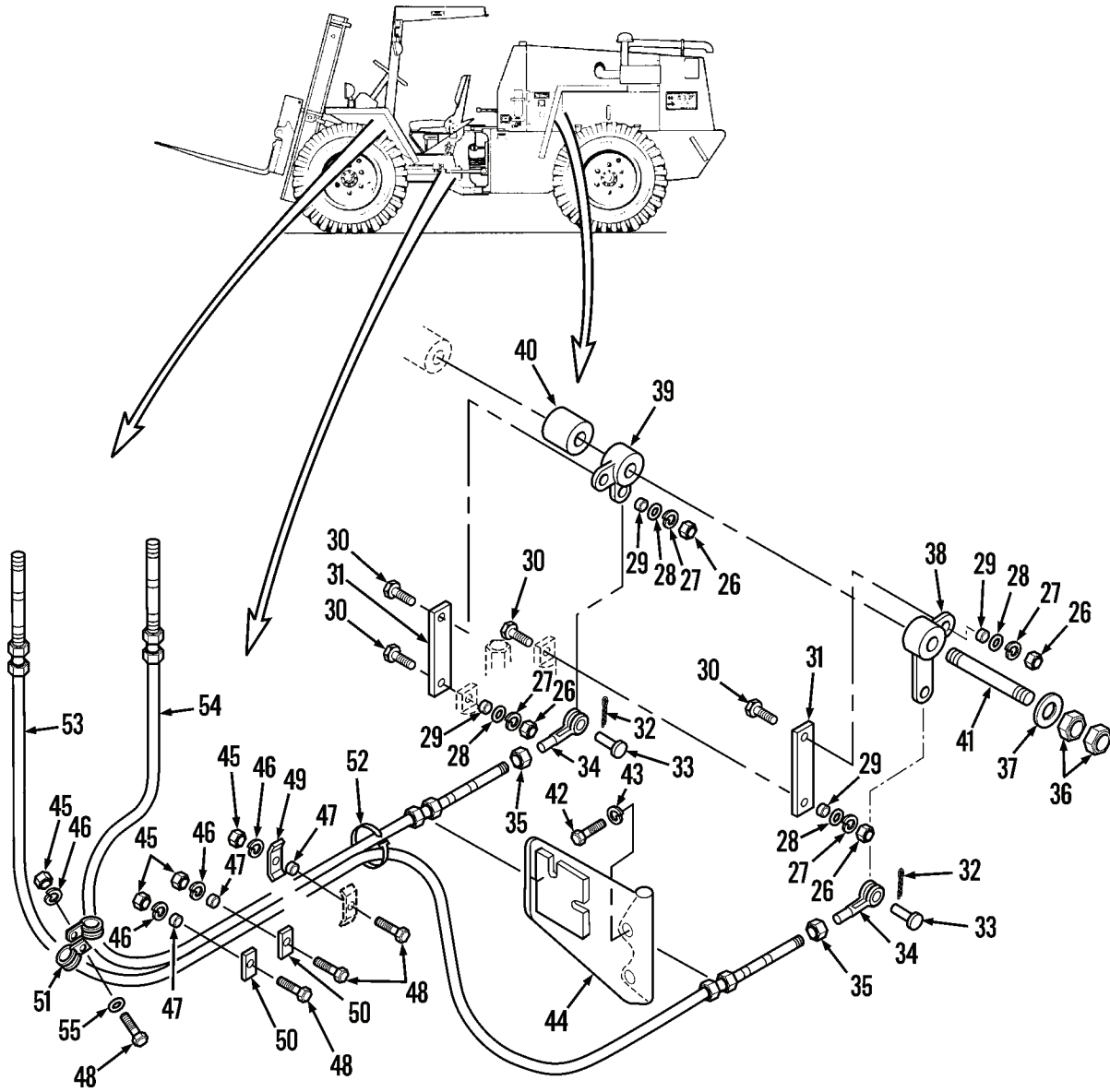

444-1091

Figure 2. Transmission Control Cables.

**CLEANING****WARNING**

DO NOT smoke or permit any open flame in area of machine while you are handling fuel. Wear fuel-resistant gloves. If exposed to fuel, promptly wash exposed skin and change fuel-soaked clothing. Failure to follow this warning may result in injury personnel.

1. Use clean diesel fuel to clean cables (Figure 3, Items 53 and 54) and control lever balls (Figure 3, Items 16 and 23). Dry thoroughly.

**WARNING**

- Solvent cleaning compound MIL-PRF-680 Type III is an environmentally compliant and low toxic material. However, it may be irritating to the eyes and skin. Use protective gloves and goggles. Use in well-ventilated areas. Keep away from open flames and other sources of ignition. Failure to do so may result in injury or death to personnel.
- Particles blown by compressed air are hazardous. DO NOT exceed 15 PSI (103 kPa) nozzle pressure when drying parts with compressed air. DO NOT direct compressed air against human skin. Make sure air stream is directed away from user and other personnel in the area. To prevent injury, user must wear protective goggles or face shield. Failure to follow this warning may result in injury to personnel.

2. Use solvent cleaning compound to clean all other parts. Dry thoroughly.

**END OF TASK****INSPECTION/REPAIR**

1. Inspect cables (Figure 3, Items 53 and 54). Replace if cracked, worn, damaged, twisted, or distorted.
2. Inspect spring (Figure 3, Item 10). Replace if cracked, worn, damaged, distorted, or permanently set.
3. Inspect all other parts. Replace if cracked, worn, damaged, distorted, or missing or with damaged threads.



INSPECTION/REPAIR - CONTINUED

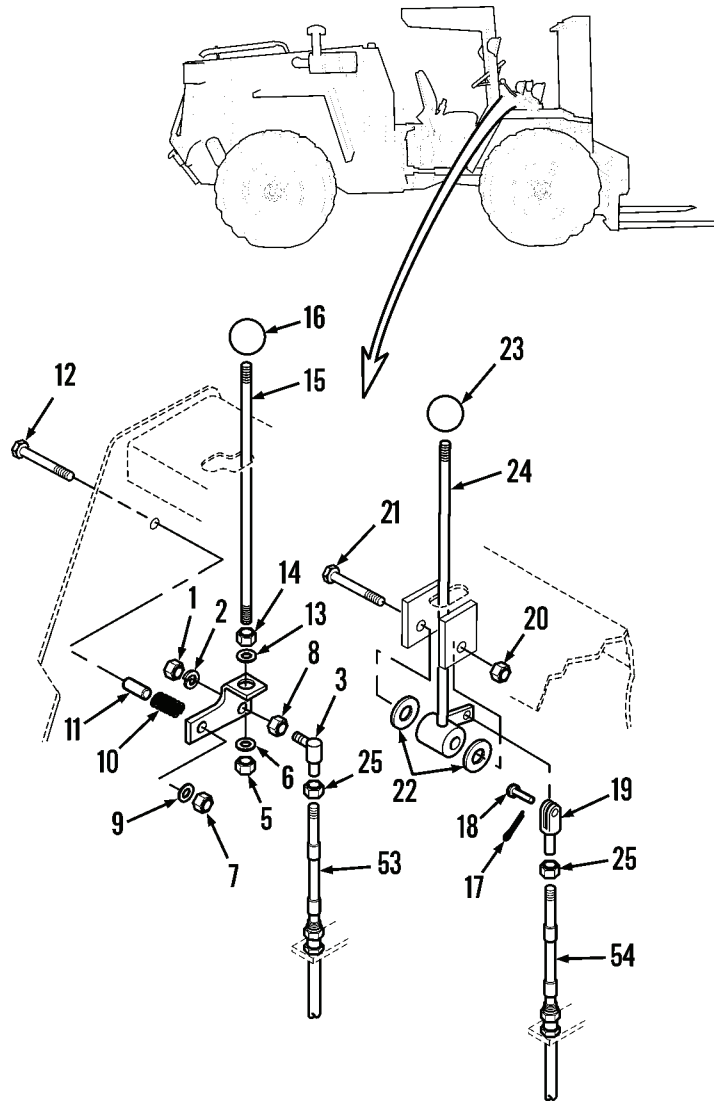

444-1090

Figure 3. Transmission Linkage Controls.

END OF TASK

---

**INSTALLATION/REPLACEMENT**

1. At operator's compartment, under floor panel, position cables (Figure 4, Items 53 and 54).
2. Install two new tiedown straps (Figure 4, Item 52) on cables (Figure 4, Items 53 and 54).
3. Position two cable clamps (Figure 4, Item 51) on vehicle.
4. Position two cable hold-down plates (Figure 4, Item 50), three spacers (Figure 4, Item 47), clamp (Figure 4, Item 49), and washer (Figure 4, Item 55) on vehicle.
5. Install four capscrews (Figure 4, Item 48), new lockwashers (Figure 4, Item 46), and nuts (Figure 4, Item 45).
6. At transmission, position cable bracket (Figure 4, Item 44), two new lockwashers (Figure 4, Item 43), capscrews (Figure 4, Item 42), stud (Figure 4, Item 41), spacer (Figure 4, Item 40), inner bellcrank (Figure 4, Item 39), outer bellcrank (Figure 4, Item 38), and washer (Figure 4, Item 37).
7. Install two nuts (Figure 4, Item 36) on stud (Figure 4, Item 41).
8. At outer bellcrank (Figure 4, Item 38) and inner bellcrank (Figure 4, Item 39), install two nuts (Figure 4, Item 35) on cables (Figure 4, Items 53 and 54).
9. Install and position two clevises (Figure 4, Item 34) on cables (Figure 4, Items 53 and 54).
10. Install two clevis pins (Figure 4, Item 33) on clevises (Figure 4, Item 34).
11. Install two new cotter pins (Figure 4, Item 32) on clevis pins (Figure 4, Item 33).
12. Position two links (Figure 4, Item 31) on vehicle.
13. Install four capscrews (Figure 4, Item 30) on links (Figure 4, Item 31).
14. Install four spacers (Figure 4, Item 29), washers (Figure 4, Item 28), new lockwashers (Figure 4, Item 27), and nuts (Figure 4, Item 26) on capscrews (Figure 4, Item 30).

INSTALLATION/REPLACEMENT - CONTINUED

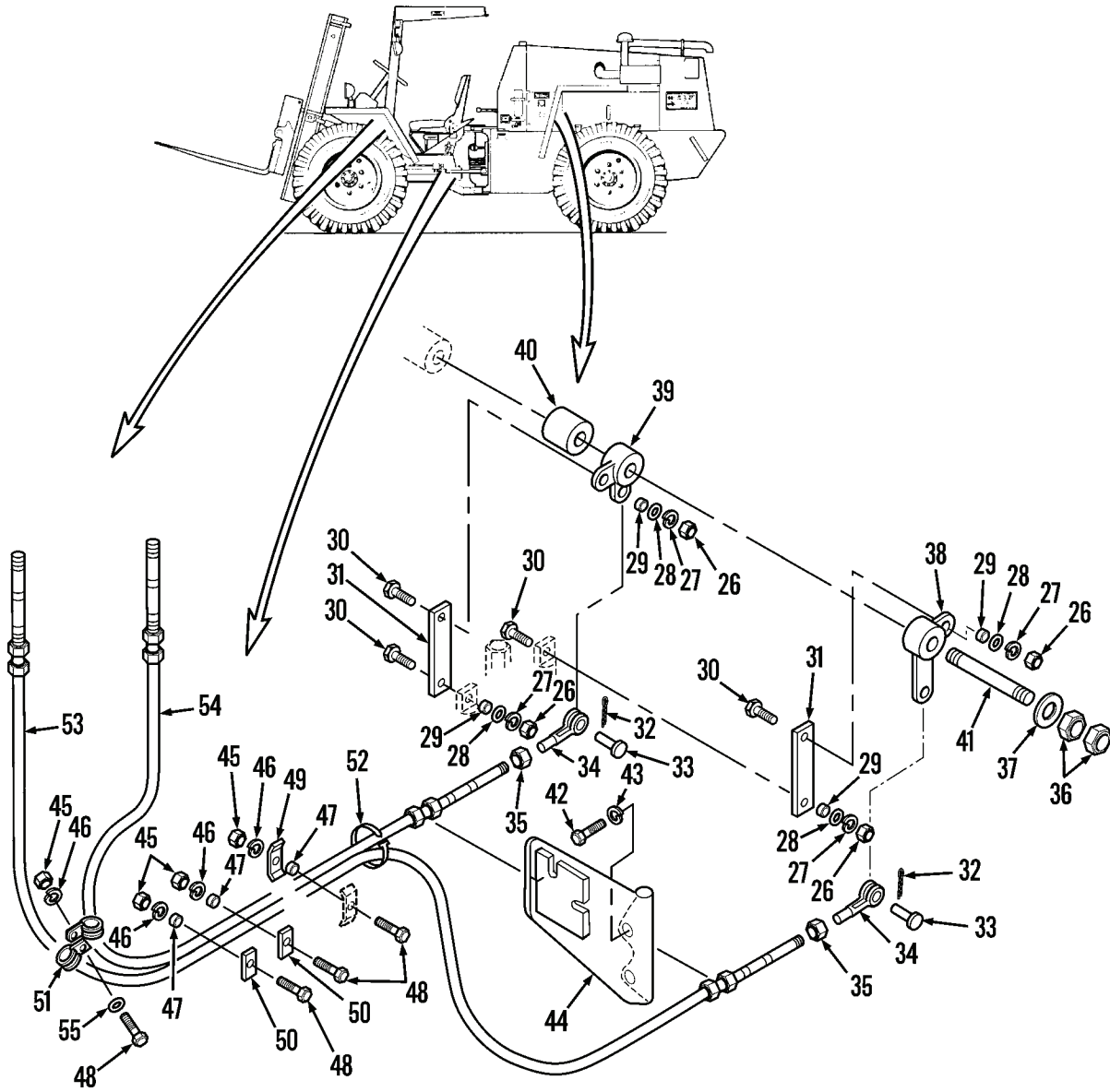

444-1091

Figure 4. Transmission Control Cables.

---

**INSTALLATION/REPLACEMENT - CONTINUED**

15. At instrument panel, attach cables (Figure 5, Items 53 and 54) to bracket and tighten cable nuts.
16. Install two nuts (Figure 5, Item 25) on cables (Figure 5, Items 53 and 54).
17. Install control lever (Figure 5, Item 24) on vehicle.
18. Install control lever knob (Figure 5, Item 23) on control lever (Figure 5, Item 24).
19. Position control lever (Figure 5, Item 24) between two brackets.
20. Position two washers (Figure 5, Item 22) and install capscrew (Figure 5, Item 21) and nut (Figure 5, Item 20).
21. Install clevis (Figure 5, Item 19) in cable (Figure 5, Item 54) and control position lever (Figure 5, Item 24) tab.
22. Tag clevis pin (Figure 5, Item 18) in clevis (Figure 5, Item 19).
23. Install new cotter pin (Figure 5, Item 17) on clevis pin (Figure 5, Item 18).
24. Install control lever knob (Figure 5, Item 16) on speed control lever (Figure 5, Item 15).
25. Install speed control lever (Figure 5, Item 15) on vehicle.
26. Install nut (Figure 5, Item 14) on speed control lever (Figure 5, Item 15).
27. Install capscrew (Figure 5, Item 12), spacer (Figure 5, Item 11), spring (Figure 5, Item 10), bracket (Figure 5, Item 8), washer (Figure 5, Item 9), and nut (Figure 5, Item 7).
28. Position speed control lever (Figure 5, Item 15) in bracket (Figure 5, Item 8).
29. Install washers (Figure 5, Items 6 and 13) and nut (Figure 5, Item 5) on speed control lever (Figure 5, Item 15).
30. Install nut (Figure 5, Item 4) on ball joint (Figure 5, Item 3).
31. Install ball joint (Figure 5, Item 3) on cable (Figure 5, Item 53) and position in bracket (Figure 5, Item 8).
32. Install new lockwasher (Figure 5, Item 2) and nut (Figure 5, Item 1) on ball joint (Figure 5, Item 3).

INSTALLATION/REPLACEMENT - CONTINUED

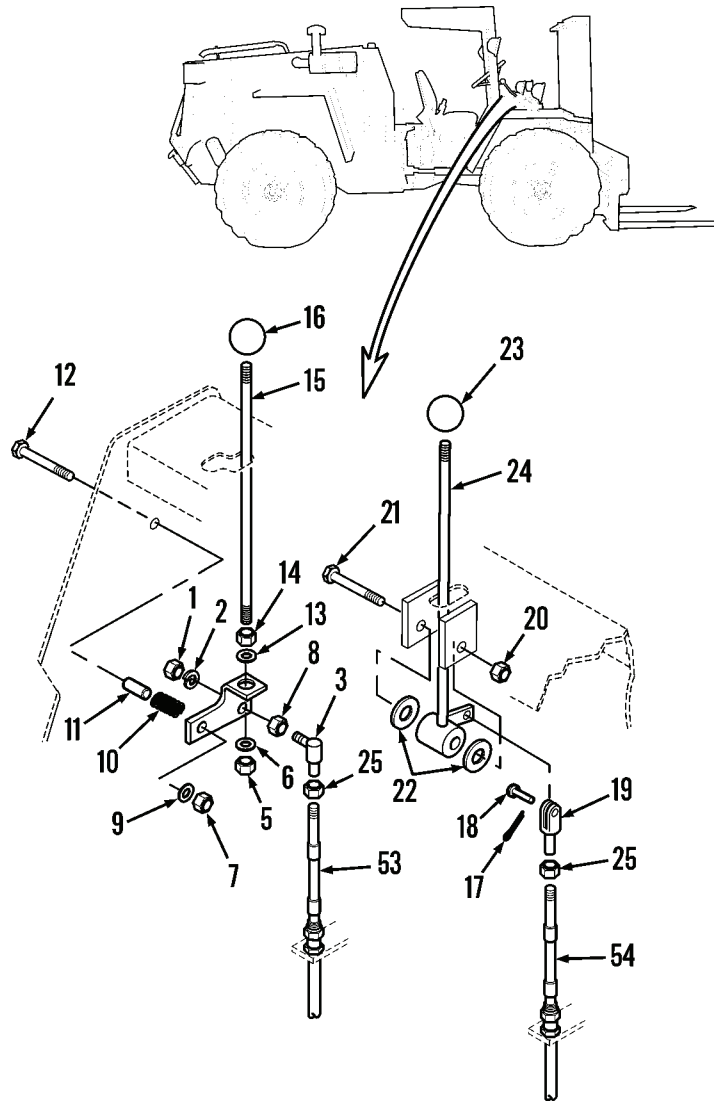

444-1090

Figure 5. Transmission Linkage Controls.

END OF TASK

## ADJUSTMENT

1. At bottom of instrument panel, loosen cable nuts, center threaded portion of cables (Figure 8, Items 53 and 54) in bracket, and retighten nuts (Figure 6).

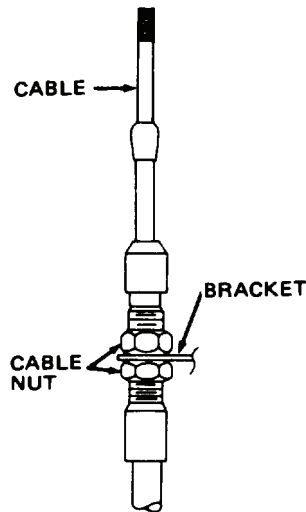

TA126961

**Figure 6. Cable Adjustment.**

2. At engine compartment, loosen cable nuts, center threaded portion of cables (Figure 8, Items 53 and 54) in bracket, and retighten nuts
3. At instrument panel, move direction control lever (Figure 8, Item 24) into forward (F) position.
4. Measure clearance between lever and front end of slot (Figure 7). Clearance must be 0.5 to 0.7 in. (13 to 18 mm). Adjust if necessary (step 5).

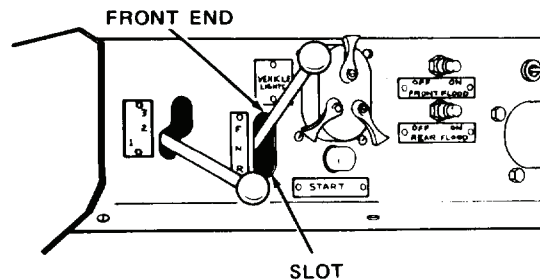

TA126962

**Figure 7. Control Lever Adjustment.**

5. Adjust as follows:
  - a. Remove cotter pin (Figure 8, Item 17) and clevis pin (Figure 8, Item 18).
  - b. Disconnect clevis (Figure 8, Item 19).
  - c. Loosen nut (Figure 8, Item 25).
  - d. Adjust clevis (Figure 8, Item 19) by threading onto or out of cable (Figure 8, Item 54).
  - e. Tighten nut (Figure 8, Item 25).
  - f. Connect clevis (Figure 8, Item 19) to control lever (Figure 8, Item 24) tab.
  - g. Install clevis pin (Figure 8, Item 18) and cotter pin (Figure 8, Item 17).
  - h. Measure clearance (step 4).

**ADJUSTMENT - CONTINUED**

6. Move direction control lever (Figure 8, Item 24) into reverse (R) position.
7. Measure clearance between lever and back end of slot. Clearance must be 0.5 to 0.7 in. (13 to 18 mm). Adjust as necessary (step 5).
8. Move speed control lever (Figure 8, Item 15) into second or 2-speed position.

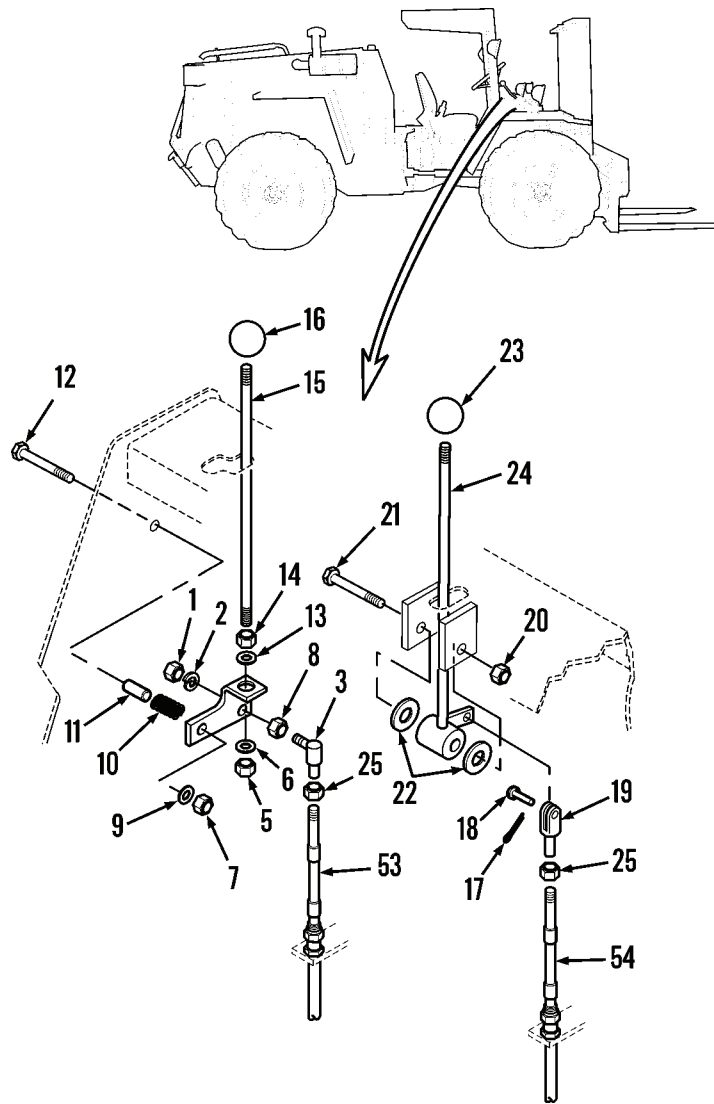

444-1090

**Figure 8. Transmission Linkage Controls.**

**ADJUSTMENT - CONTINUED**

9. Measure clearance between lever and top of slot as shown in Figure 9. Clearance must be 0.9 to 1.1 in. (23 to 28 mm). Adjust as necessary (step 10).

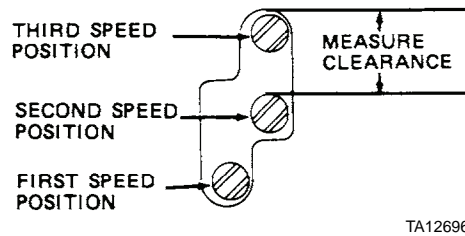

TA126963

**Figure 9. Clearance Adjustment.**

10. Adjust as follows:
- Remove nut (Figure 10, Item 1) and lockwasher (Figure 10, Item 2).
  - Detach ball joint (Figure 10, Item 3).
  - Loosen nut (Figure 10, Item 25).
  - Adjust ball joint (Figure 10, Item 3) by threading onto or out of cable (Figure 10, Item 53).
  - Tighten nut (Figure 10, Item 25).
  - Install ball joint (Figure 10, Item 3).
  - Install lockwasher (Figure 10, Item 2) and nut (Figure 10, Item 1).
  - Measure clearance (step 9).



ADJUSTMENT - CONTINUED

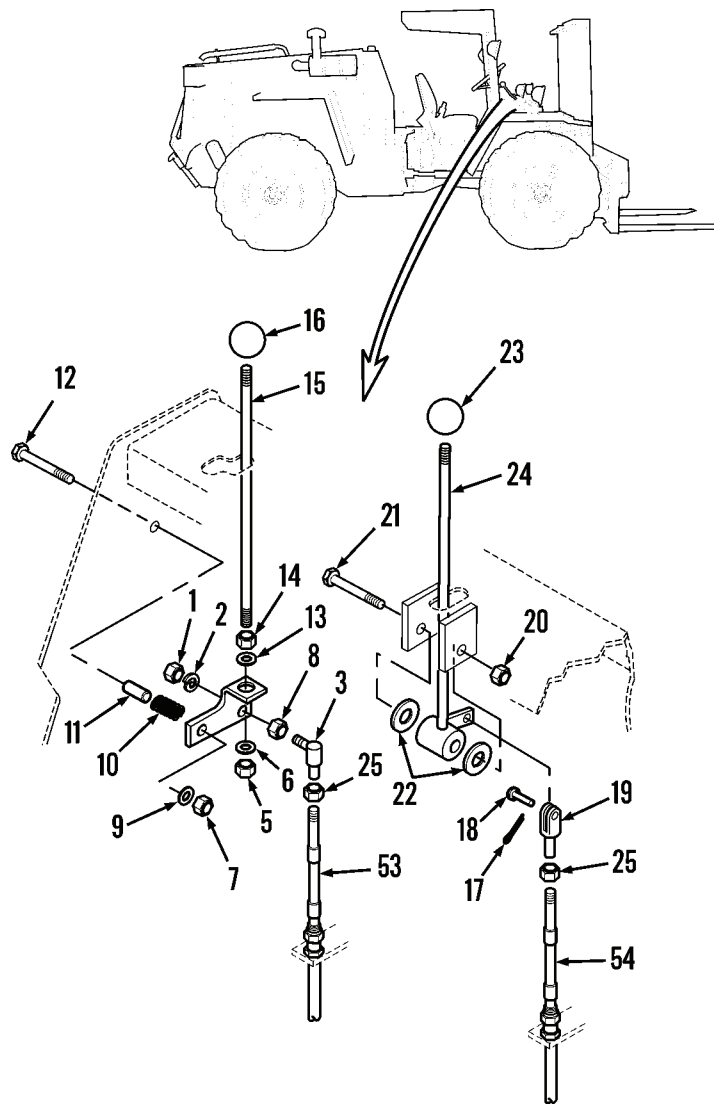

444-1090

Figure 10. Transmission Linkage Controls.

11. Move lever into first or 1 and third or 3-speed positions. Full detent must be achieved.

END OF TASK

END OF WORK PACKAGE



---

## ORGANIZATIONAL MAINTENANCE INSTRUCTIONS

### AXLE DISCONNECT LEVER REPLACEMENT

Removal, Cleaning, Inspection, Installation

---

#### INITIAL SETUP

##### Maintenance Level

Organizational

##### Tools and Special Tools

Tool kit, general mechanic's (Item 15, WP 0309)

Shop equipment, common no. 1 (Item 2, WP 0309)

Torque Wrench, 0 to 50 lb-ft range

##### Materials/Parts

Cleaning compound, solvent (Item 10, WP 0310)

##### Materials/Parts - Continued

Rag, wiping (Item 26, WP 0310)

Cotter pin (2)

Lockwasher (4)

##### Equipment Condition

Vehicle turned (articulated) to left

Engine OFF

Parking brake applied

Front cover panel removed (WP 0184)

---

**REMOVAL**

1. At rear of operator's compartment, remove knob (Figure 1, Item 1), cotter pin (Figure 1, Item 2), pin (Figure 1, Item 3), and upper lever (Figure 1, Item 4) from rod (Figure 1, Item 11). Discard cotter pin.
2. At transmission, remove nut (Figure 1, Item 5), lockwasher (Figure 1, Item 6), and capscrew (Figure 1, Item 7) from clamp (Figure 1, Item 8). Discard lockwasher.
3. Remove clamp (Figure 1, Item 8) from vehicle.
4. Remove cotter pin (Figure 1, Item 9), washer (Figure 1, Item 10), and rod (Figure 1, Item 11) from bracket (Figure 1, Item 19). Discard cotter pin.

**NOTE**

Perform steps 5 and 6 only if bracket (Figure 1, Item 19) requires replacement.

5. Remove nut (Figure 1, Item 12), lockwasher (Figure 1, Item 13), washer (Figure 1, Item 14), capscrew (Figure 1, Item 15), and clamp (Figure 1, Item 16) from bracket (Figure 1, Item 19). Discard lockwasher.
6. Remove two capscrews (Figure 1, Item 17) and lockwashers (Figure 1, Item 18) from bracket (Figure 1, Item 19) and remove bracket from vehicle. Discard lockwashers.

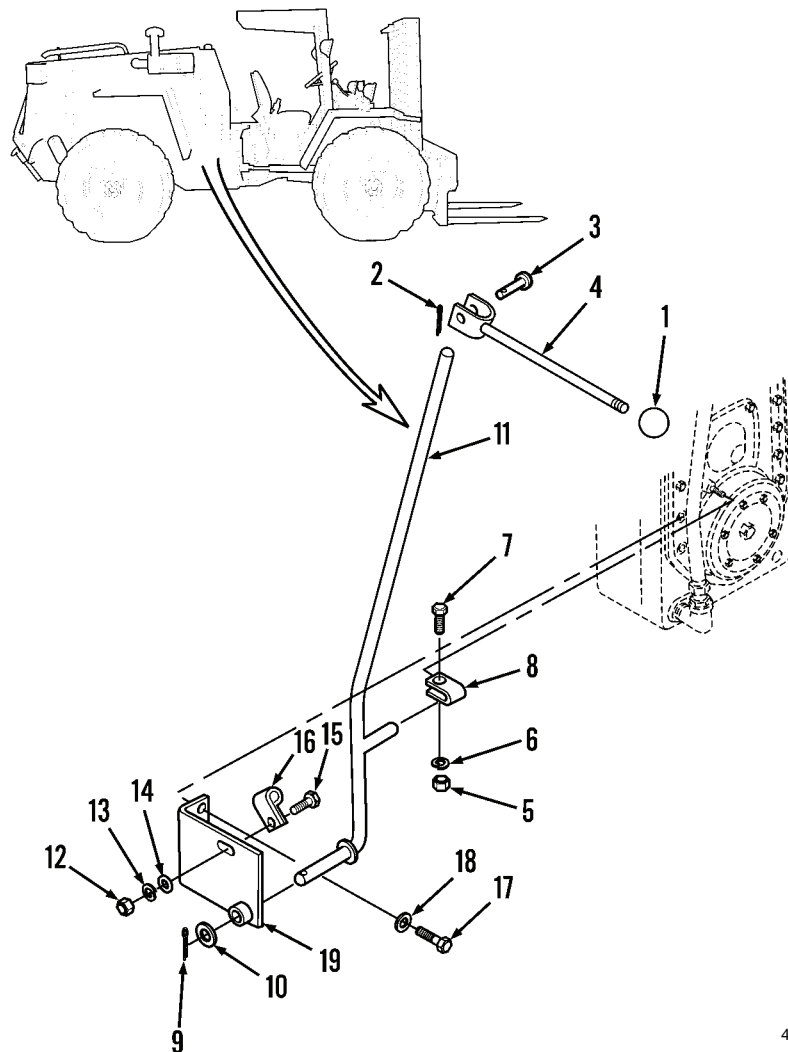

444-1095

Figure 1. Axle Disconnect Lever.

**END OF TASK**

**CLEANING****WARNING**

- Solvent cleaning compound MIL-PRF-680 Type III is an environmentally compliant and low toxic material. However, it may be irritating to the eyes and skin. Use protective gloves and goggles. Use in well-ventilated areas. Keep away from open flames and other sources of ignition. Failure to do so may result in injury or death to personnel.
- Particles blown by compressed air are hazardous. DO NOT exceed 15 PSI (103 kPa) nozzle pressure when drying parts with compressed air. DO NOT direct compressed air against human skin. Make sure air stream is directed away from user and other personnel in the area. To prevent injury, user must wear protective goggles or face shield. Failure to follow this warning may result in injury to personnel.

Use solvent cleaning compound to clean all parts. Dry thoroughly.

**END OF TASK****INSPECTION**

1. Inspect upper lever (Figure 1, Item 4) and rod (Figure 1, Item 11). Replace if bent or cracked; repair threads by chasing with proper size die.
2. Inspect knob (Figure 1, Item 1). Replace if cracked, chipped, or threads damaged.
3. Inspect pin (Figure 1, Item 3). Replace if bent or cracked.
4. Inspect clamps (Figure 1, Items 8 and 16). Replace if cracked.
5. Inspect bracket (Figure 1, Item 19). Replace if bent, cracked, or spacer damaged.

**END OF TASK**

---

**INSTALLATION**

1. Position bracket (Figure 2, Item 19) on transmission.
2. Install two new lockwashers (Figure 2, Item 18) and capscrews (Figure 2, Item 17). Tighten to 37 to 41 lb-ft (50 to 56 Nm).
3. Position clamp (Figure 2, Item 16) on dipstick assembly.
4. Install capscrew (Figure 2, Item 15), washer (Figure 2, Item 14), new lockwasher (Figure 2, Item 13), and nut (Figure 2, Item 12) on bracket (19).
5. Position rod (Figure 2, Item 11) in bracket (Figure 2, Item 19).
6. Position washer (Figure 2, Item 10) on rod (Figure 2, Item 11).
7. Install new cotter pin (Figure 2, Item 9) on rod (Figure 2, Item 11).
8. Position clamp (Figure 2, Item 8) on rod (Figure 2, Item 11) and align holes in clamp with holes in shift rod.
9. Install capscrew (Figure 2, Item 7), new lockwasher (Figure 1, Item 6), and nut (Figure 2, Item 5) in clamp (Figure 2, Item 8).
10. Position upper lever (Figure 2, Item 4) on rod (Figure 2, Item 11).
11. Install pin (Figure 2, Item 3) on upper lever (Figure 2, Item 4).
12. Install new cotter pin (Figure 2, Item 2) on pin (Figure 2, Item 3).
13. Install knob (Figure 2, Item 1) on upper lever (Figure 2, Item 4).

INSTALLATION - CONTINUED

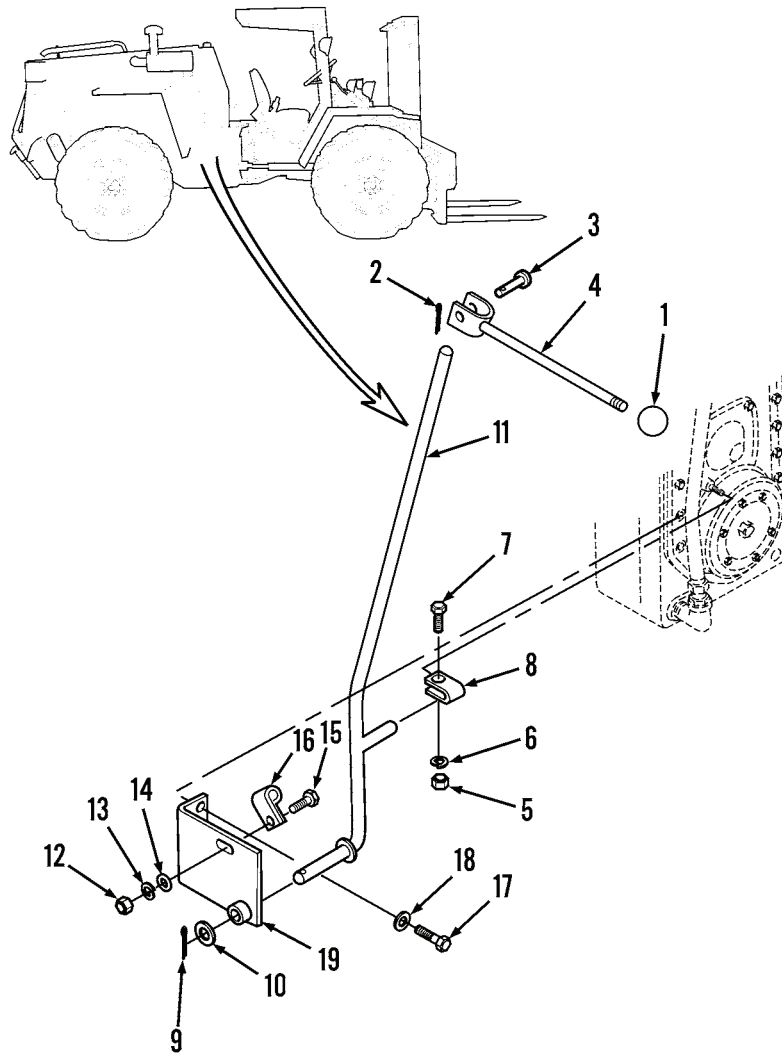

444-1095

Figure 2. Axle Disconnect Lever.

14. Install front cover panel (WP 0184).

END OF TASK

END OF WORK PACKAGE





---

# ORGANIZATIONAL MAINTENANCE INSTRUCTIONS

## TRANSMISSION DIPSTICK TUBE REPLACEMENT

### Removal, Cleaning, Inspection, Installation

---

#### INITIAL SETUP

**Maintenance Level**

Organizational

**Tools and Special Tools**

Tool kit, general mechanic's (Item 15, WP 0309)

Shop equipment, common no. 1 (Item 2, WP 0309)

**Materials/Parts**

Cleaning compound, solvent (Item 10, WP 0310)

Diesel fuel, arctic (Item 14, WP 0310)

**Materials/Parts - Continued**

Diesel fuel, DF-2 (Item 15, WP 0310)

Rag, wiping (Item 26, WP 0310)

Lockwasher

**Equipment Condition**

Vehicle turned (articulated) to left

Engine OFF

Parking brake applied

Front cover panel removed (WP 0184)

Transmission oil drained (WP 0143)

---

**REMOVAL**

1. Loosen two hose clamps (Figure 1, Item 1) on dipstick hose (Figure 1, Item 2).
2. Remove dipstick hose (Figure 1, Item 2) from vehicle.
3. Remove nut (Figure 1, Item 3), lockwasher (Figure 1, Item 4), washer (Figure 1, Item 5), capscrew (Figure 1, Item 6), and clamp (Figure 1, Item 7) from transmission. Discard lockwasher.
4. Loosen nut (Figure 1, Item 8) and remove dipstick tube assembly (Figure 1, Item 9).

**NOTE**

Do not remove straight connector or elbow unless replacement is necessary.

5. Remove straight connector (Figure 1, Item 10) from elbow (Figure 1, Item 11).
6. Remove elbow (Figure 1, Item 11) from transmission.

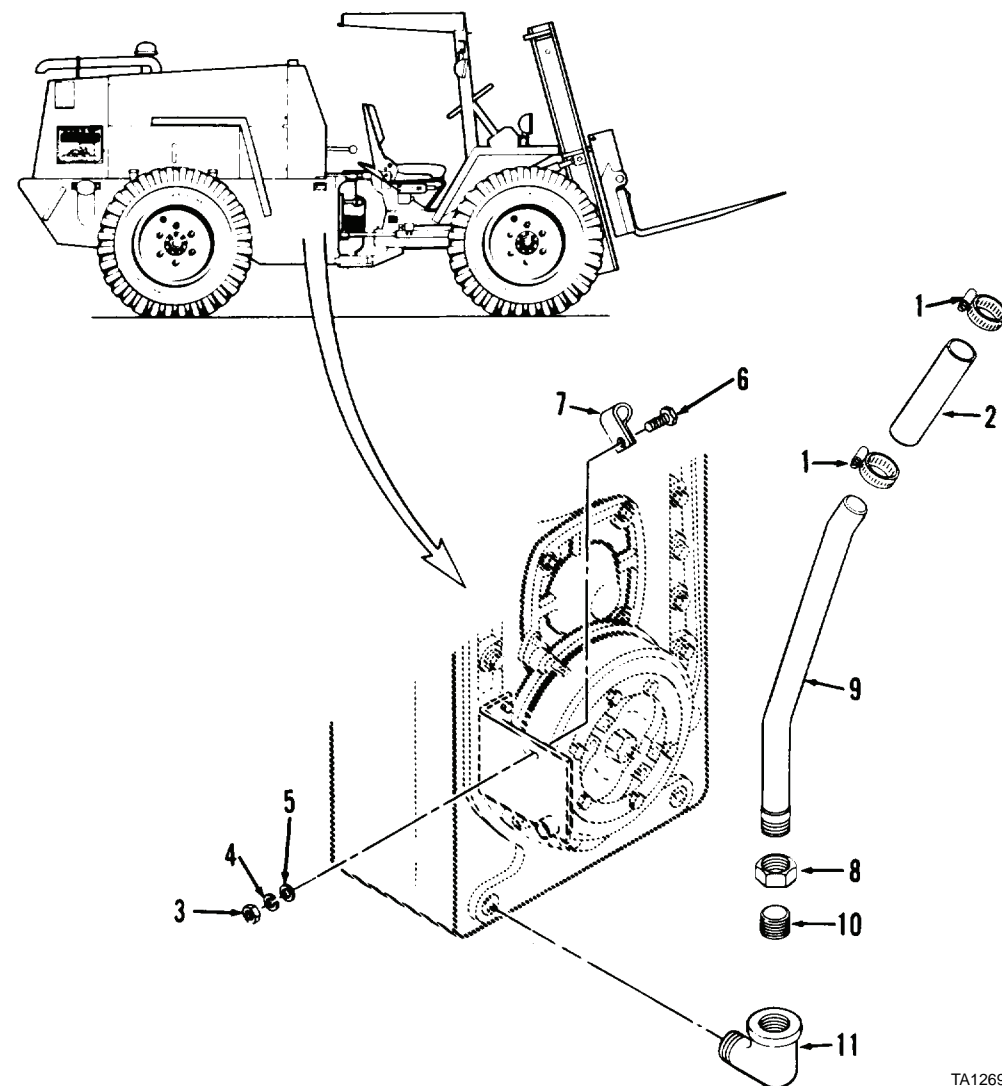

Figure 1. Transmission Dipstick Tube.

TA126965

**END OF TASK**

**CLEANING****WARNING**

- DO NOT smoke or permit any open flame in area of machine while you are handling fuel. Wear fuel-resistant gloves. If exposed to fuel, promptly wash exposed skin and change fuel-soaked clothing. Failure to follow this warning may result in injury to personnel.
- Particles blown by compressed air are hazardous. DO NOT exceed 15 PSI (103 kPa) nozzle pressure when drying parts with compressed air. DO NOT direct compressed air against human skin. Make sure air stream is directed away from user and other personnel in the area. To prevent injury, user must wear protective goggles or face shield. Failure to follow this warning may result in injury to personnel.
- Solvent cleaning compound MIL-PRF-680 Type III is an environmentally compliant and low toxic material. However, it may be irritating to the eyes and skin. Use protective gloves and goggles. Use in well-ventilated areas. Keep away from open flames and other sources of ignition. Failure to do so may result in injury or death to personnel.

1. Use clean diesel fuel to clean dipstick hose (Figure 1, Item 2). Dry thoroughly.
2. Use solvent cleaning compound to clean all other parts. Dry thoroughly.

**END OF TASK****INSPECTION**

1. Inspect hose clamps (Figure 1, Item 1). Replace if damaged.
2. Inspect dipstick hose (Figure 1, Item 2). Replace if cracked, cut, or torn.
3. Inspect straight connector (Figure 1, Item 10) and elbow (Figure 1, Item 11). Replace if cracked, distorted, or threads damaged.

**END OF TASK****INSTALLATION**

1. Install elbow (Figure 1, Item 11) on transmission, if removed.
2. Install straight connector (Figure 1, Item 10) on elbow (Figure 1, Item 11), if removed.
3. Position dipstick tube assembly (Figure 1, Item 9) on transmission.
4. Tighten nut (Figure 1, Item 8) on dipstick tube assembly (Figure 1, Item 9).
5. Position clamp (Figure 1, Item 7) and carefully slip over dipstick tube assembly (Figure 1, Item 9).
6. Install capscrew (Figure 1, Item 6), washer (Figure 1, Item 5), new lockwasher (Figure 1, Item 4), and nut (Figure 1, Item 3) to secure clamp (Figure 1, Item 7).
7. Position two hose clamps (Figure 1, Item 1) on dipstick hose (Figure 1, Item 2).
8. Position dipstick hose (Figure 1, Item 2) on dipstick tube assembly (Figure 1, Item 9).
9. Tighten bottom clamp (Figure 1, Item 1) only.
10. Install front cover panel (WP 0184).
11. Fill transmission with oil (WP 0143).

**END OF TASK****END OF WORK PACKAGE**



# ORGANIZATIONAL MAINTENANCE INSTRUCTIONS

## TRANSMISSION CONTROL VALVE INSPECTION

### Inspection

#### INITIAL SETUP

##### Maintenance Level

Organizational

##### Tools and Special Tools

Tool kit, general mechanic's (Item 15, WP 0309)

##### Materials/Parts

Rag, wiping (Item 26, WP 0310)

##### Equipment Conditions

Engine OFF

Vehicle parked on level surface

Parking brake applied

Left side panel removed (WP 0179)

#### INSPECTION

1. On left side of transmission, inspect valve spools for oil leakage. Notify Direct Support Maintenance if oil leakage is observed.
2. Inspect back-up alarm switch for oil leakage at mounting area. Notify Direct Support Maintenance if oil leakage is observed.
3. Inspect neutral start switch for oil leakage at mounting area. Notify Direct Support Maintenance if oil leakage is observed.
4. Inspect control valve for oil leakage at mounting area. Notify Direct Support Maintenance if oil leakage is observed.

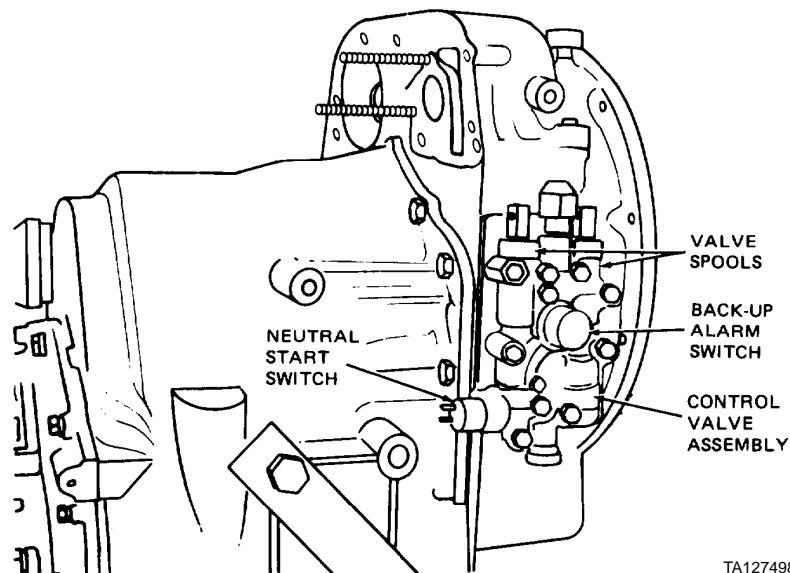

TA127498

Figure 1. Transmission Control Valve Inspection.

END OF TASK

END OF WORK PACKAGE



---

# ORGANIZATIONAL MAINTENANCE INSTRUCTIONS

## TRANSMISSION HOSES, LINES, AND FITTINGS REPLACEMENT

### Removal, Cleaning, Inspection, Installation

---

#### INITIAL SETUP

##### Maintenance Level

Organizational

##### Tools and Special Tools

Tool kit, general mechanic's (Item 15, WP 0309)

Shop equipment, common no. 1 (Item 2, WP 0309)

##### Materials/Parts

Cap set, protective (Item 9, WP 0310)

Cleaning compound, solvent (Item 10, WP 0310)

##### Materials/Parts - Continued

Diesel fuel, arctic (Item 14, WP 0310)

Diesel fuel, DF-2 (Item 15, WP 0310)

Rag, wiping (Item 26, WP 0310)

Lockwasher

##### Equipment Condition

Engine OFF

Parking brake applied

Right side panel removed (WP 0179)

Tow bar lowered and grille opened (WP 0176)

---

## NOTE

Cap and plug all openings.

### REMOVAL

1. Loosen nut (Figure 1, Item 1) on transmission to cooler hose (Figure 1, Item 2).
2. Disconnect transmission to cooler hose (Figure 1, Item 2) from straight connector (Figure 1, Item 3).
3. Remove straight connector (Figure 1, Item 3) from transmission.
4. Loosen nut (Figure 1, Item 4) on cooler to transmission hose (Figure 1, Item 5).
5. Disconnect cooler to transmission hose (Figure 1, Item 5) from straight connector (Figure 1, Item 6).
6. Remove straight connector (Figure 1, Item 6) from transmission.
7. Loosen nut (Figure 1, Item 7) on transmission to cooler tube assembly (Figure 1, Item 8).
8. Disconnect transmission to cooler hose (Figure 1, Item 2) and remove from vehicle.
9. Loosen nut (Figure 1, Item 9) on cooler to transmission tube assembly (Figure 1, Item 10).
10. Disconnect cooler to transmission hose (Figure 1, Item 5) and remove from vehicle.
11. Remove capscrew (Figure 1, Item 11), lockwasher (Figure 1, Item 12), nut (Figure 1, Item 13), and hose clamp (Figure 1, Item 14). Discard lockwasher.
12. Loosen nut (Figure 1, Item 15) on transmission to cooler tube assembly (Figure 1, Item 8).
13. Disconnect transmission to cooler tube assembly (Figure 1, Item 8) and remove from vehicle.
14. Remove elbow (Figure 1, Item 16) and pipe nipple (Figure 1, Item 17) from transmission oil cooler.
15. Loosen nut (Figure 1, Item 18) on cooler to transmission tube assembly (Figure 1, Item 10).
16. Disconnect cooler to transmission tube assembly (Figure 1, Item 10) and remove from vehicle.
17. Remove elbow (Figure 1, Item 19) and pipe nipple (Figure 1, Item 20) from transmission oil cooler.

### END OF TASK

### CLEANING



WARNING



- DO NOT smoke or permit any open flame in area of machine while you are handling fuel. Wear fuel-resistant gloves. If exposed to fuel, promptly wash exposed skin and change fuel-soaked clothing. Failure to follow this warning may result in injury to personnel.
  - Solvent cleaning compound MIL-PRF-680 Type III is an environmentally compliant and low toxic material. However, it may be irritating to the eyes and skin. Use protective gloves and goggles. Use in well-ventilated areas. Keep away from open flames and other sources of ignition. Failure to do so may result in injury or death to personnel.
1. Use clean diesel fuel to clean hoses (Figure 1, Items 2 and 5). Dry thoroughly.
  2. Use solvent cleaning compound to clean all other parts and dry thoroughly.



CLEANING - CONTINUED

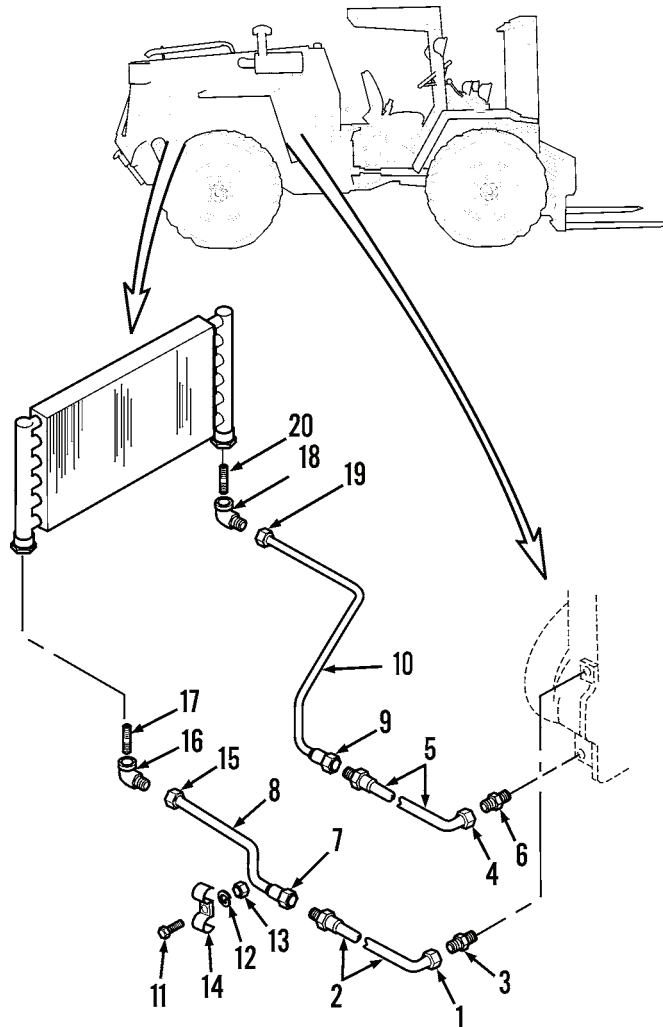

444-1099

Figure 1. Transmission Hoses, Lines, and Fittings.

END OF TASK

---

**INSPECTION**

1. Inspect hoses (Figure 2, Items 2 and 5). Replace if cracked, split, or fittings damaged.
2. Inspect tube assemblies (Figure 2, Items 8 and 10). Replace if cracked, dented, or fittings damaged.
3. Inspect all other parts. Replace if cracked, damaged, or threads worn.

**END OF TASK****INSTALLATION**

1. Install pipe nipples (Figure 2, Items 17 and 20) on transmission oil cooler.
2. Install elbows (Figure 2, Items 16 and 19) on pipe nipples (Figure 2, Items 17 and 20).
3. Position cooler to transmission tube assembly (Figure 2, Item 10) and connect to elbow (Figure 2, Item 19).
4. Tighten nut (Figure 2, Item 18) on cooler to transmission tube assembly (Figure 2, Item 10).
5. Position transmission to cooler tube assembly (Figure 2, Item 8) and connect to elbow (Figure 2, Item 16).
6. Tighten nut (Figure 2, Item 15) on transmission to cooler tube assembly (Figure 2, Item 8).
7. In engine compartment, position hose clamp (Figure 2, Item 14) on tube assemblies (Figure 2, Items 8 and 10).
8. Install nut (Figure 2, Item 13), new lockwasher (Figure 2, Item 12), and capscrew (Figure 2, Item 11) on hose clamp (Figure 2, Item 14).
9. Position cooler to transmission hose (Figure 2, Item 5) and connect to tube assembly (Figure 2, Item 10).
10. Tighten nut (Figure 2, Item 9) on cooler to transmission tube assembly (Figure 2, Item 10).
11. Position transmission to cooler hose (Figure 2, Item 2) and connect to tube assembly (Figure 2, Item 8).
12. Install straight connectors (Figure 2, Items 3 and 6) on transmission.
13. Connect cooler to transmission hose (Figure 2, Item 5) to straight connector (Figure 2, Item 6).
14. Tighten nut (Figure 2, Item 4) on cooler to transmission hose (Figure 2, Item 5).
15. Connect transmission to cooler hose (Figure 2, Item 2) to straight connector (Figure 2, Item 3) and tighten nut (Figure 2, Item 1).

INSTALLATION - CONTINUED

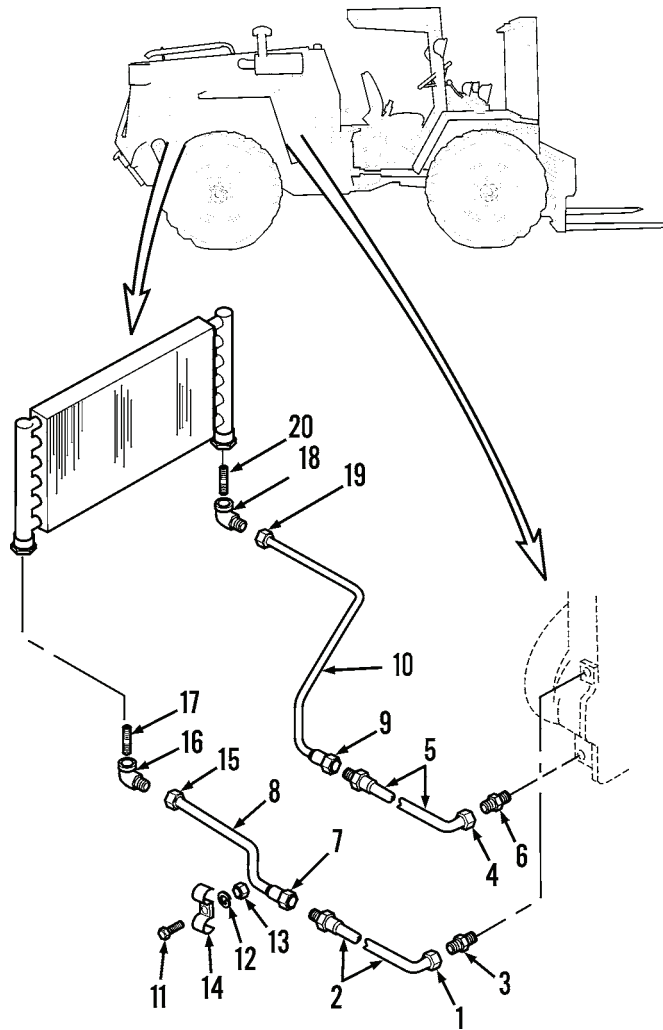

444-1099

Figure 2. Transmission Hoses, Lines, and Fittings.

END OF TASK

END OF WORK PACKAGE



---

## ORGANIZATIONAL MAINTENANCE INSTRUCTIONS

### TRANSMISSION OIL COOLER REPLACEMENT

#### Removal, Installation

---

#### INITIAL SETUP

##### Maintenance Level

Organizational

##### Tools and Special Tools

Tool kit, general mechanic's (Item 15, WP 0309)

Shop equipment, common no. 1 (Item 2, WP 0309)

##### Materials/Parts

Diesel fuel, arctic (Item 14, WP 0310)

Diesel fuel, DF-2 (Item 15, WP 0310)

Lubricating oil, OE/HDO-10 (Item 20, WP 0310)

Lockwasher (4)

##### Equipment Condition

Engine OFF

Vehicle parked on level surface

##### Equipment Condition - Continued

Parking brake applied

Grille removed (WP 0177)

Rear floodlights removed (WP 0111 and WP 0112)

Stop and taillights removed (WP 0115 and WP 0116)

Radiator coolant reservoir removed (WP 0082 and WP 0083)

Side panels removed (WP 0179)

Transmission to cooler and cooler to transmission tube assemblies disconnected at transmission oil cooler and capped to prevent entry of foreign material (WP 0152)

Elbows and pipe nipples removed from transmission oil cooler (WP 0152)

Back-up alarm removed (WP 0130 and WP 0131)

---

**REMOVAL**

1. Remove four capscrews (Figure 1, Item 1), lockwashers (Figure 1, Item 2), and clamps (Figure 1, Item 3) from transmission oil cooler (Figure 1, Item 4). Discard lockwashers.
2. Remove transmission oil cooler (Figure 1, Item 4) from vehicle.

**END OF TASK****INSTALLATION**

1. Position transmission oil cooler (Figure 1, Item 4) on vehicle.
2. Install four clamps (Figure 1, Item 3), new lockwashers (Figure 1, Item 2), and capscrews (Figure 1, Item 1).

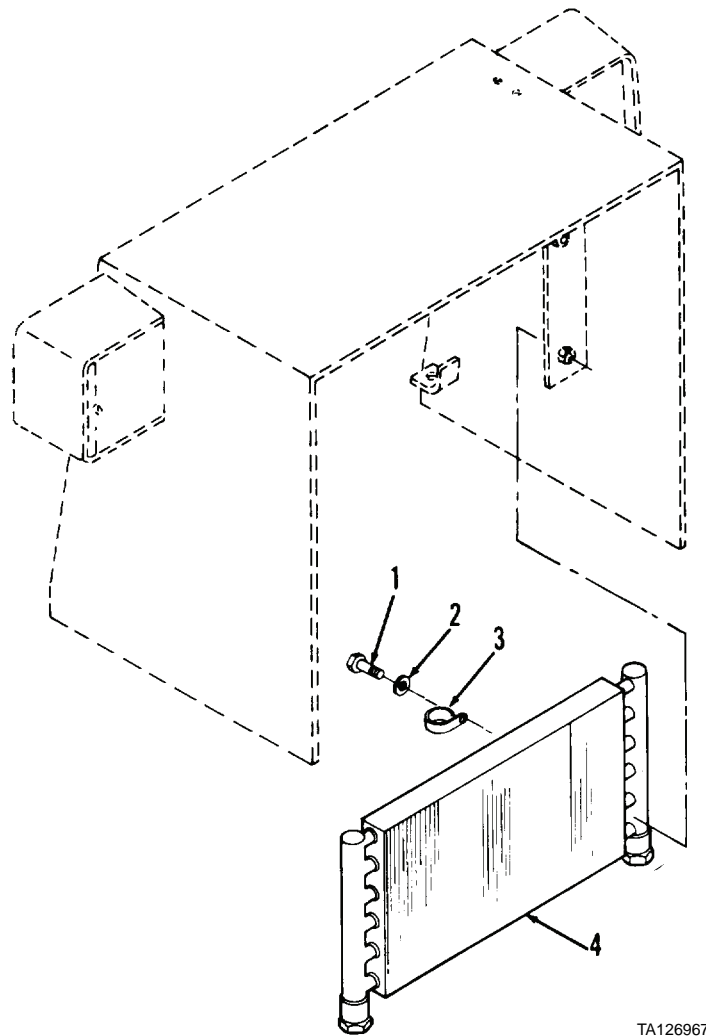

TA126967

**Figure 1. Transmission Oil Cooler.****END OF TASK****END OF WORK PACKAGE**

---

## ORGANIZATIONAL MAINTENANCE INSTRUCTIONS

### FRONT DRIVE SHAFT AND SUPPORT BEARING MAINTENANCE

Service, Removal, Disassembly, Cleaning, Inspection, Assembly, Installation

---

#### INITIAL SETUP

##### Maintenance Level

Organizational

##### Tools and Special Tools

Tool kit, general mechanic's (Item 15, WP 0309)

Shop equipment, common no. 1 (Item 2, WP 0309)

##### Materials/Parts

Cleaning compound, solvent (Item 10, WP 0310)

Grease, automotive and artillery (Item 17, WP 0310)

Rag, wiping (Item 26, WP 0310)

##### Materials/Parts - Continued

Cotter pin

Lockwasher (4)

##### References

LO 10-3930-638-12

WP 0155

##### Equipment Condition

Vehicle steering turned either left or right

Vehicle parked on level surface

Parking brake applied

Engine OFF

Wheels chocked

Chassis guard removed (WP 0188)

---

**SERVICE**

1. Clean lubrication fitting (Figure 1, Item 13) of yoke (Figure 1, Item 4) by wiping with a clean rag.
2. Lubricate yoke (Figure 1, Item 4) (LO 10-3930-638-12). Lubricate until grease is pressed out of yoke.
3. Clean lubrication fitting of drive shaft support bearing (Figure 1, Item 9) by wiping with a clean rag.
4. Lubricate drive shaft support bearing (Figure 1, Item 9) (LO 10-3930-638-12). Lubricate until grease is pressed out of bearing.

**CAUTION**

Do not use a high-pressure grease gun to apply lubricant to lubrication fitting of universal joint.  
Using a high-pressure grease gun will damage seals.

5. Clean lubrication fitting (Figure 1, Item 14) of universal joint (Figure 1, Item 17) by wiping with a clean rag.
6. Lubricate universal joint (Figure 1, Item 17) (LO 10-3930-638-12). Lubricate until grease is pressed out of lubrication fitting (Figure 1, Item 14).

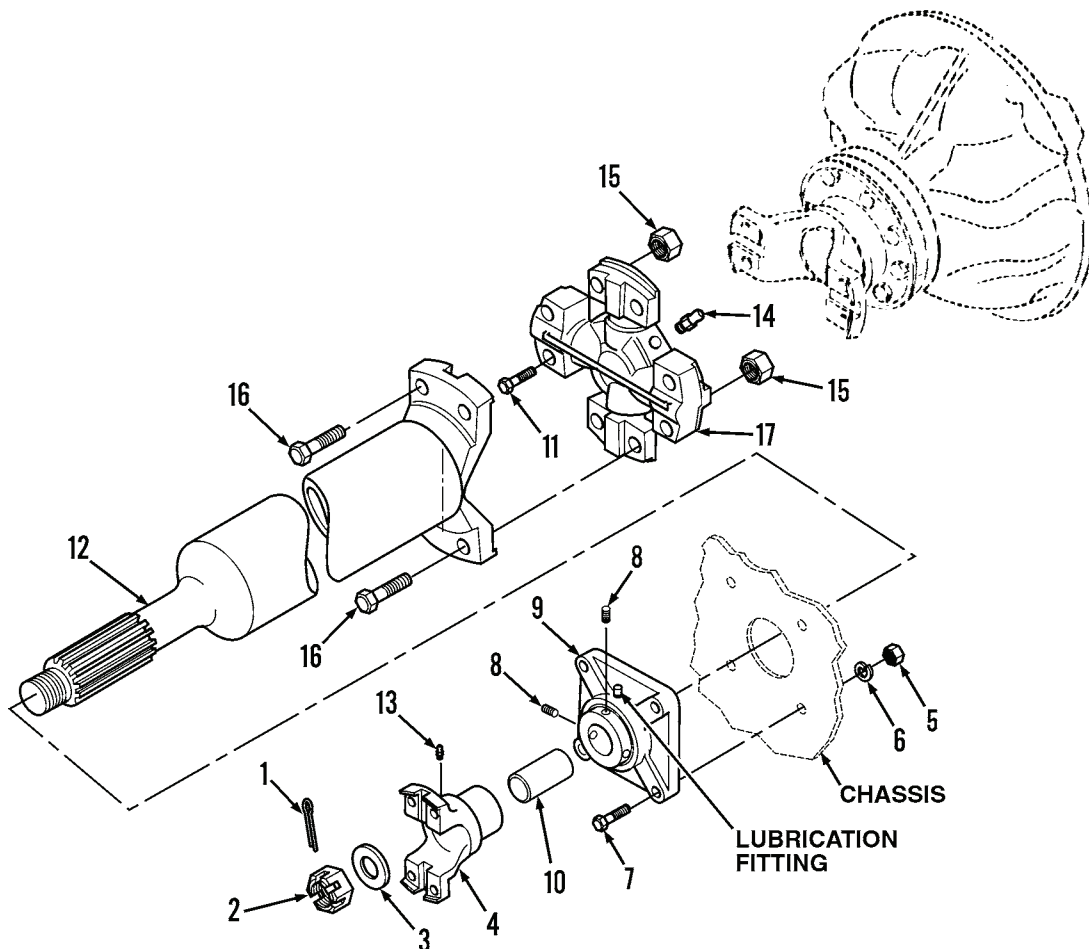

444-1101

**Figure 1. Front Drive Shaft.****END OF TASK**



**REMOVAL**

1. Disconnect center drive shaft from yoke (Figure 1, Item 4) of front drive shaft (Figure 1, Item 12) (WP 0155, *Removal*, step 2).
2. Remove cotter pin (Figure 1, Item 1), nut (Figure 1, Item 2), washer (Figure 1, Item 3), and yoke (Figure 1, Item 4) from front drive shaft (Figure 1, Item 12). Use puller. Discard cotter pin.
3. Remove four nuts (Figure 1, Item 5), lockwashers (Figure 1, Item 6), capscrews (Figure 1, Item 7), and drive shaft support bearing (Figure 1, Item 9) from vehicle. Discard lockwashers.
4. Remove two setscrews (Figure 1, Item 8) and collar (Figure 1, Item 10) from drive shaft support bearing (Figure 1, Item 9).

**NOTE**

Remove front drive shaft by moving toward rear of vehicle, dropping universal joint down, and pulling forward.

5. Remove four capscrews (Figure 1, Item 11) and universal joint (Figure 1, Item 17), with front drive shaft (Figure 1, Item 12) attached, from vehicle.

**END OF TASK****DISASSEMBLY**

1. Remove lubrication fitting (Figure 1, Item 13) from yoke (Figure 1, Item 4).
2. Remove lubrication fitting and two setscrews (Figure 1, Item 8) from drive shaft support bearing (Figure 1, Item 9).
3. Remove lubrication fitting (Figure 1, Item 14) from universal joint (Figure 1, Item 17).
4. Remove four nuts (Figure 1, Item 15), capscrews (Figure 1, Item 16), and universal joint (Figure 1, Item 17) from front drive shaft (Figure 1, Item 12).

**END OF TASK****CLEANING****WARNING**

Solvent cleaning compound MIL-PRF-680 Type III is an environmentally compliant and low toxic material. However, it may be irritating to the eyes and skin. Use protective gloves and goggles. Use in well-ventilated areas. Keep away from open flames and other sources of ignition. Failure to do so may result in injury or death to personnel.

1. Clean drive shaft support bearing and universal joint by wiping with a clean rag moistened with solvent cleaning compound. Dry with clean rag.
2. Clean all other parts with solvent cleaning compound. Dry thoroughly.

**END OF TASK**

**INSPECTION**

1. Inspect drive shaft support bearing and universal joint. Replace if worn or damaged.
2. Inspect drive shaft. Replace if cracked, dented, bent, or twisted.
3. Inspect all other parts and mounting hardware. Replace if damaged, worn, or threads are damaged.

**END OF TASK****ASSEMBLY**

1. Install universal joint (Figure 2, Item 17) on front drive shaft (Figure 2, Item 12) with four capscrews (Figure 2, Item 16) and nuts (Figure 2, Item 15).
2. Install lubrication fitting (Figure 2, Item 14) on universal joint (Figure 2, Item 17).
3. Install two setscrews (Figure 2, Item 8) and lubrication fitting on drive shaft support bearing (Figure 2, Item 9).
4. Install lubrication fitting (Figure 2, Item 13) on yoke (Figure 2, Item 4).

**END OF TASK****INSTALLATION****WARNING**

Solvent cleaning compound MIL-PRF-680 Type III is an environmentally compliant and low toxic material. However, it may be irritating to the eyes and skin. Use protective gloves and goggles. Use in well-ventilated areas. Keep away from open flames and other sources of ignition. Failure to do so may result in injury or death to personnel.

1. At yoke of front axle differential, clean mounting surfaces by wiping with a clean rag moistened with solvent cleaning compound. Dry with a clean rag.
2. Position front drive shaft (Figure 2, Item 12), with universal joint (Figure 2, Item 17) attached, on vehicle.
3. Align mounting holes of universal joint (Figure 2, Item 17) with mounting holes on differential yoke.
4. Install four capscrews (Figure 2, Item 11). Tighten capscrews to 40 to 50 lb-ft (54 to 68 Nm).
5. Install collar (Figure 2, Item 10) and two setscrews (Figure 2, Item 8) in drive shaft support bearing (Figure 2, Item 9).
6. Position drive shaft support bearing (Figure 2, Item 9) over end of front drive shaft (Figure 2, Item 12).
7. Install drive shaft support bearing (Figure 2, Item 9) on vehicle with four capscrews (Figure 2, Item 7), new lockwashers (Figure 2, Item 6), and nuts (Figure 2, Item 5).
8. Align yoke (Figure 2, Item 4) with differential yoke and install yoke on splined end of front drive shaft (Figure 2, Item 12).
9. Install washer (Figure 2, Item 3) and nut (Figure 2, Item 2). Tighten nut to 300 to 400 lb-ft (407 to 542 Nm).
10. Install new cotter pin (Figure 2, Item 1).
11. Connect center drive shaft to yoke (Figure 2, Item 4) of front drive shaft (Figure 2, Item 12) (WP 0155, *Installation*, step 3).
12. Lubricate yoke (Figure 2, Item 4), drive shaft support bearing (Figure 2, Item 9), and universal joint (Figure 2, Item 17) (refer to *Service* in this work package).

INSTALLATION - CONTINUED

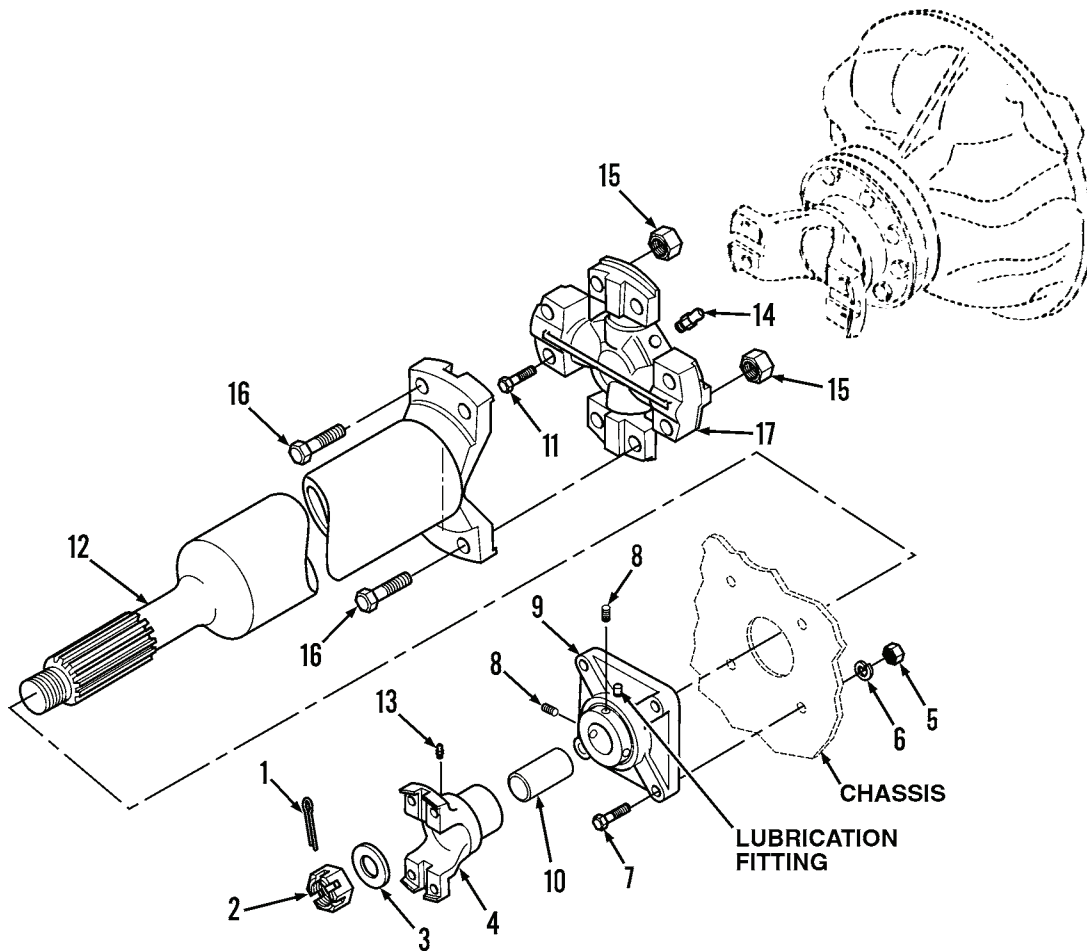

444-1101

Figure 2. Front Drive Shaft.

13. Install chassis guard (WP 0188).

END OF TASK

END OF WORK PACKAGE



---

## ORGANIZATIONAL MAINTENANCE INSTRUCTIONS

### CENTER DRIVE SHAFT MAINTENANCE

Service, Removal, Disassembly, Cleaning, Inspection, Assembly, Installation

---

#### INITIAL SETUP

##### Maintenance Level

Organizational

##### Tools and Special Tools

Tool kit, general mechanic's (Item 15, WP 0309)

Shop equipment, common no. 1 (Item 2, WP 0309)

##### Materials/Parts

Cleaning compound, solvent (Item 10, WP 0310)

Cloth, crocus (Item 12, WP 0310)

Grease, automotive and artillery (Item 17, WP 0310)

##### Materials/Parts - Continued

Rag, wiping (Item 26, WP 0310)

Seal shaft kit

##### References

LO 10-3930-638-12

##### Equipment Condition

Vehicle parked on level surface

Parking brake applied

Engine OFF

Wheels chocked

---

**SERVICE**

1. Clean lubrication fitting (Figure 1, Item 5) of slip yoke (Figure 1, Item 10) by wiping with a clean rag.
2. Lubricate slip yoke (Figure 1, Item 10) (LO 10-3930-638-12). Lubricate until grease is pressed out of slip yoke.

**CAUTION**

Do not use a high-pressure grease gun to apply lubricant to grease fittings of universal joints. Using a high-pressure grease gun will damage seals.

3. Clean lubrication fitting (Figure 1, Item 4) at each of two universal joints (Figure 1, Item 3) by wiping with a clean rag.
4. Lubricate two universal joints (Figure 1, Item 3) (LO 10-3930-638-12). Lubricate until grease is pressed out of fitting.

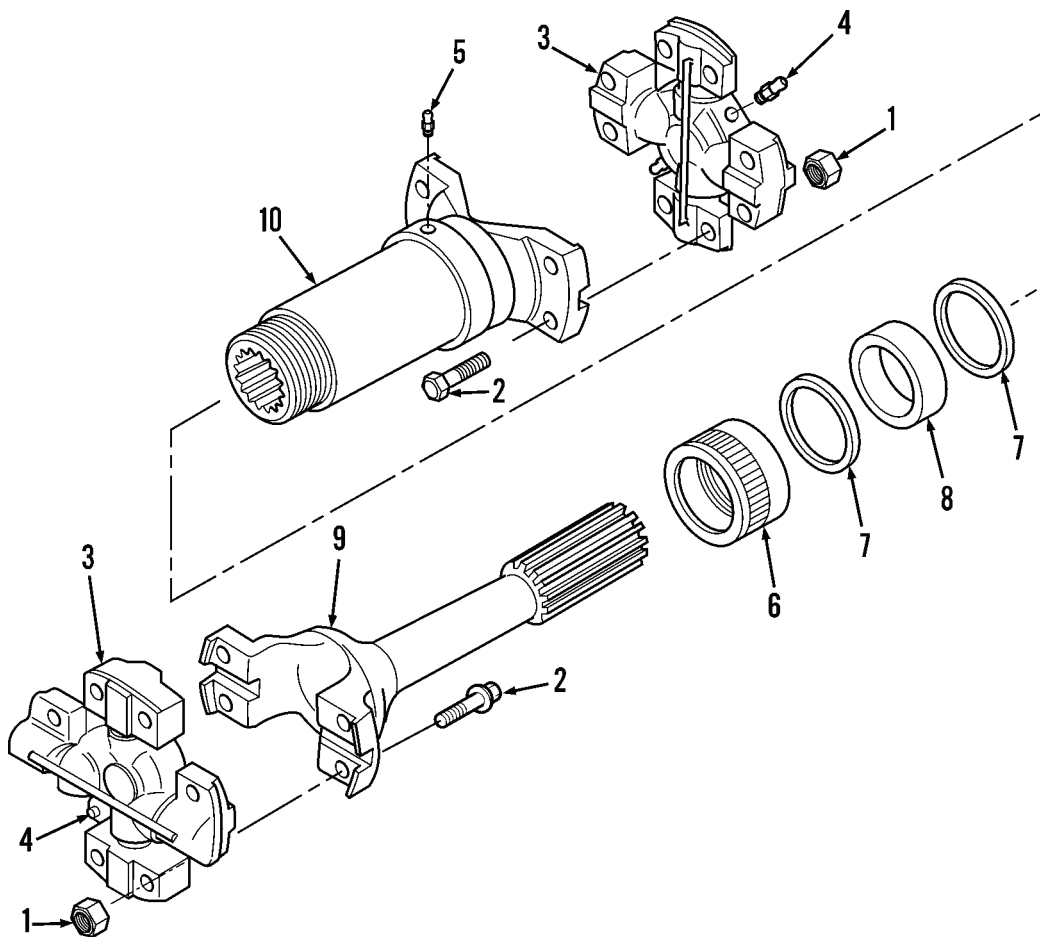

444-1103

**Figure 1. Center Drive Shaft.**

**END OF TASK**

**REMOVAL**

1. At parking brake flange, remove four capscrews and disconnect universal joint (Figure 1, Item 3) of splined yoke (Figure 1, Item 9) from parking brake flange. Support splined yoke.
2. At drive shaft support bearing, remove four capscrews and disconnect second universal joint (Figure 1, Item 3) of slip yoke (Figure 1, Item 10) from front drive shaft.
3. Push splined yoke (Figure 1, Item 9) into slip yoke (Figure 1, Item 10) and remove center drive shaft assembly from vehicle.

**END OF TASK****DISASSEMBLY**

1. Remove eight nuts (Figure 1, Item 1), capscrews (Figure 1, Item 2), and two universal joints (Figure 1, Item 3) from center drive shaft assembly.
2. Remove lubrication fitting (Figure 1, Item 4) from each of two universal joints (Figure 1, Item 3).
3. Loosen cap (Figure 1, Item 6) and slide cap, two washers (Figure 1, Item 7), and washer (Figure 1, Item 8) back on splined yoke (Figure 1, Item 9).
4. Remove splined yoke (Figure 1, Item 9) from slip yoke (Figure 1, Item 10).
5. Remove two washers (Figure 1, Item 7), washer (Figure 1, Item 8), and cap (Figure 1, Item 6) from splined yoke (Figure 1, Item 9). Discard washers and cap.
6. Remove lubrication fitting (Figure 1, Item 5) from slip yoke (Figure 1, Item 10).

**END OF TASK****CLEANING****WARNING**

Solvent cleaning compound MIL-PRF-680 Type III is an environmentally compliant and low toxic material. However, it may be irritating to the eyes and skin. Use protective gloves and goggles. Use in well-ventilated areas. Keep away from open flames and other sources of ignition. Failure to do so may result in injury or death to personnel.

1. Clean two universal joints by wiping with a clean rag moistened with solvent cleaning compound. Dry with clean rag.
2. Clean all other parts with solvent cleaning compound. Dry thoroughly.

**END OF TASK****INSPECTION**

1. Inspect splined yoke, slip yoke, and two universal joints. Replace if cracked, bent, dented, or splines are twisted or broken. Remove any burrs with crocus cloth.
2. Inspect all other parts and mounting hardware. Replace if damaged, worn, or threads are damaged.

**END OF TASK**

## ASSEMBLY

1. Install lubrication fitting (Figure 2, Item 5) on slip yoke (Figure 2, Item 10).
2. Position cap (Figure 2, Item 6), two washers (Figure 2, Item 7), and washer (Figure 2, Item 8) on splined yoke (Figure 2, Item 9).
3. Align splined yoke (Figure 2, Item 9) with slip yoke (Figure 2, Item 10) and install splined yoke in slip yoke.
4. Position two new washers (Figure 2, Item 7), new washer (Figure 2, Item 8), and new cap (Figure 2, Item 6) against end of slip yoke (Figure 2, Item 10) and tighten cap.
5. Install lubrication fitting (Figure 2, Item 4) on each of two universal joints (Figure 2, Item 3).
6. Install two universal joints (Figure 2, Item 3) on center drive shaft assembly with eight capscrews (Figure 2, Item 2) and nuts (Figure 2, Item 1).

## END OF TASK

## INSTALLATION



### WARNING

Solvent cleaning compound MIL-PRF-680 Type III is an environmentally compliant and low toxic material. However, it may be irritating to the eyes and skin. Use protective gloves and goggles. Use in well-ventilated areas. Keep away from open flames and other sources of ignition. Failure to do so may result in injury or death to personnel.

1. At parking brake flange and at yoke of front drive shaft, clean mounting surfaces by wiping with a clean rag moistened with solvent cleaning compound. Dry with a clean rag.
2. Push splined yoke (Figure 2, Item 9) into slip yoke (Figure 2, Item 10) and position center drive shaft assembly on vehicle.
3. At drive shaft support bearing, connect universal joint (Figure 2, Item 3) of slip yoke (Figure 2, Item 10) to yoke of front drive shaft with four capscrews. Support splined yoke (Figure 2, Item 9). Tighten capscrews to 40 to 50 lb-ft (54 to 68 Nm).
4. At parking brake flange, connect second universal joint (Figure 2, Item 3) of splined yoke (Figure 2, Item 9) to parking brake flange with four capscrews. Tighten capscrews to 40 to 50 lb-ft (54 to 68 Nm).
5. Lubricate two universal joints (Figure 2, Item 3) and slip yoke (Figure 2, Item 10) (refer to *Service* in this work package).



INSTALLATION - CONTINUED

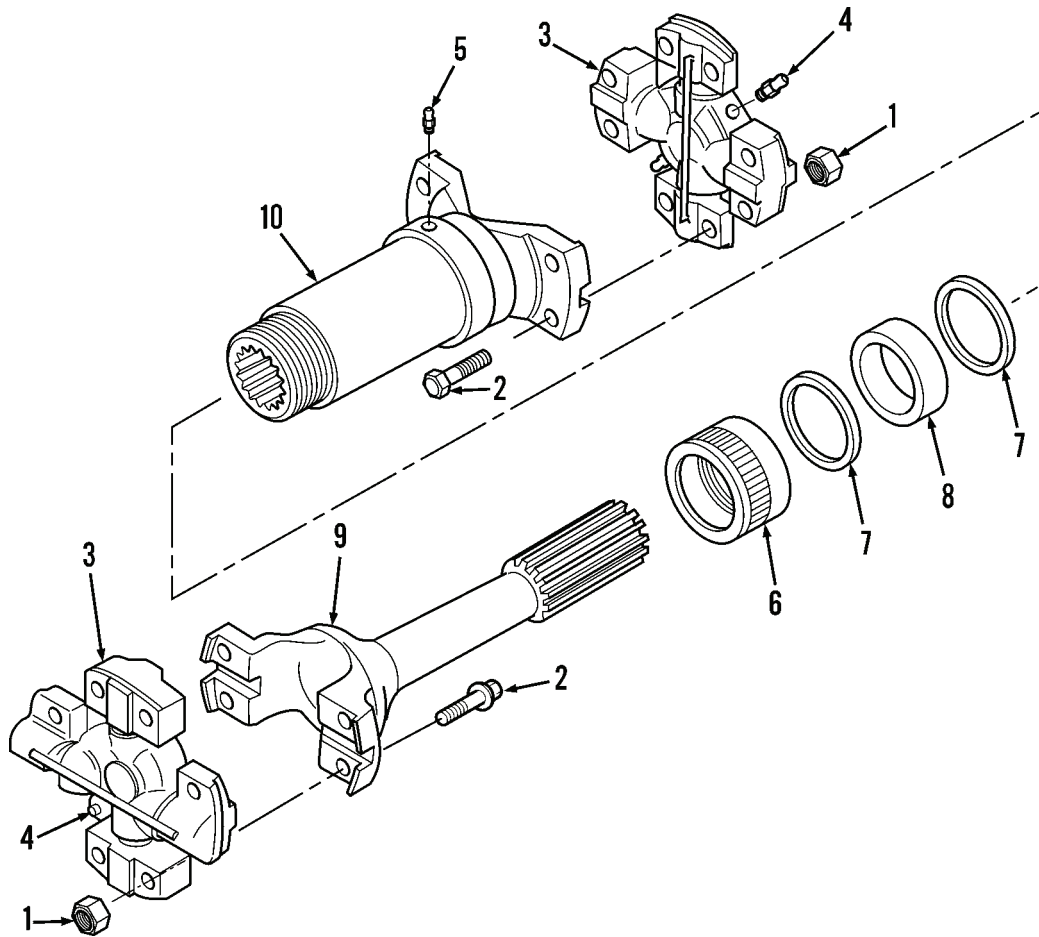

444-1103

Figure 2. Center Drive Shaft.

END OF TASK

END OF WORK PACKAGE



---

## ORGANIZATIONAL MAINTENANCE INSTRUCTIONS

### REAR DRIVE SHAFT MAINTENANCE

Service, Removal, Disassembly, Cleaning, Inspection, Assembly, Installation

---

#### INITIAL SETUP

##### Maintenance Level

Organizational

##### Tools and Special Tools

Tool kit, general mechanic's (Item 15, WP 0309)

Shop equipment, common no. 1 (Item 2, WP 0309)

##### Materials/Parts

Cleaning compound, solvent (Item 10, WP 0310)

Cloth, crocus (Item 12, WP 0310)

Grease, automotive and artillery (Item 17, WP 0310)

##### Materials/Parts - Continued

Rag, wiping (Item 26, WP 0310)

Seal shaft kit

##### References

LO 10-3930-638-12

##### Equipment Condition

Vehicle parked on level surface

Parking brake applied

Engine OFF

Wheels chocked

---

**SERVICE**

1. Clean lubrication fitting (Figure 1, Item 6) of slip yoke (Figure 1, Item 14) by wiping with a clean rag.
2. Lubricate slip yoke (Figure 1, Item 14) (LO 10-3930-638-12). Lubricate until grease is pressed out of slip yoke.

**CAUTION**

Do not use a high-pressure grease gun to apply lubricant to grease fittings of universal joints. Using a high-pressure grease gun will damage seals.

3. Clean lubrication fitting (Figure 1, Item 5) at each of two universal joints (Figure 1, Item 9) by wiping with a clean rag.
4. Lubricate two universal joints (Figure 1, Item 9) (LO 10-3930-638-12). Lubricate until grease is pressed out of fitting.

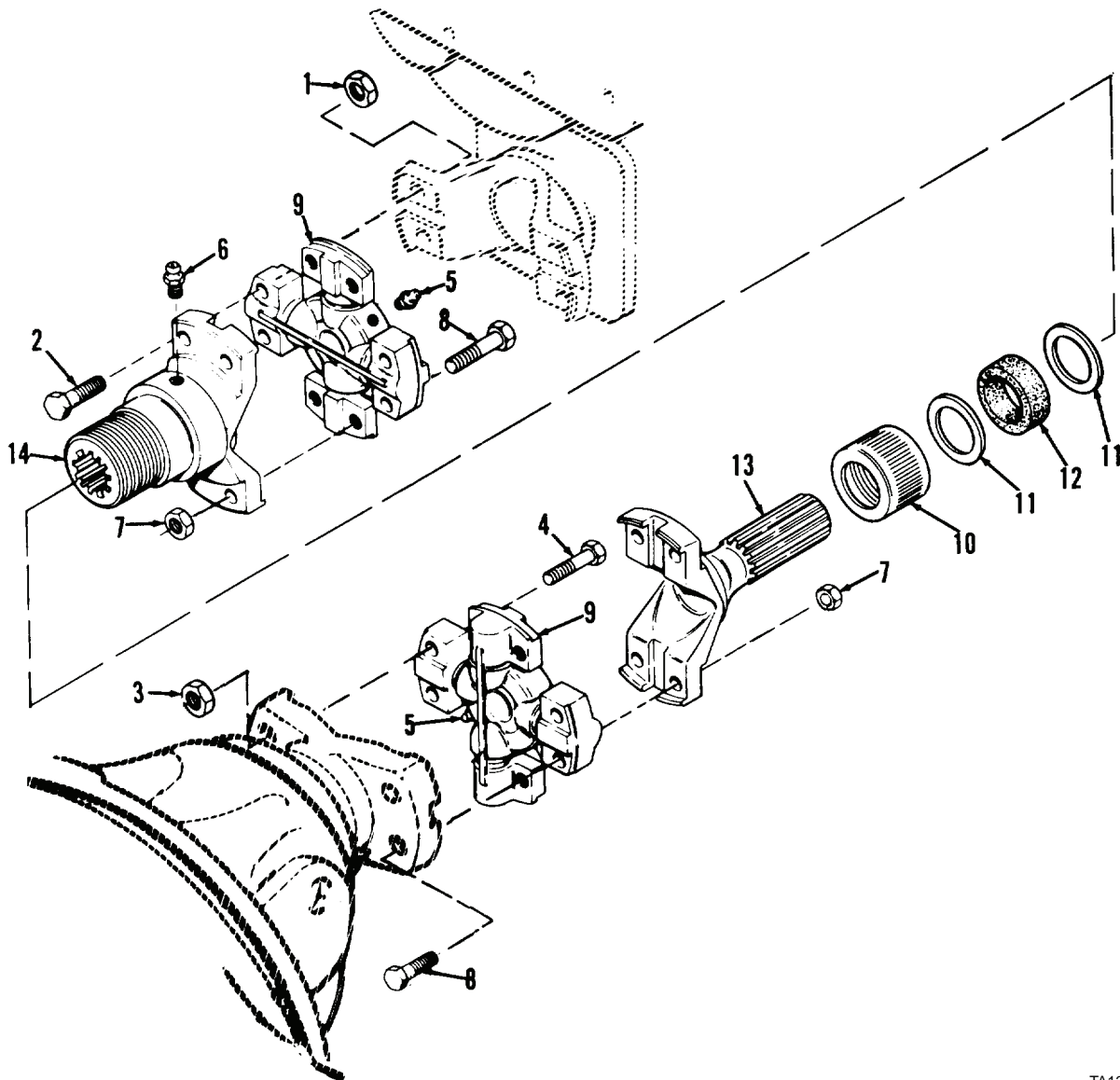

Figure 1. Rear Drive Shaft.

TA126971

END OF TASK

**REMOVAL**

1. At transmission output flange, remove four nuts (Figure 1, Item 1) and capscrews (Figure 1, Item 2) and disconnect universal joint (Figure 1, Item 9) of slip yoke (Figure 1, Item 14) from transmission output flange. Support splined yoke (Figure 1, Item 13).
2. At rear axle differential, remove four nuts (Figure 1, Item 3) and capscrews (Figure 1, Item 4) and disconnect second universal joint (Figure 1, Item 9) of splined yoke (Figure 1, Item 13) from yoke of rear axle differential.
3. Push splined yoke (Figure 1, Item 13) into slip yoke (Figure 1, Item 14) and remove rear drive shaft assembly from vehicle.

**END OF TASK****DISASSEMBLY**

1. Remove eight nuts (Figure 1, Item 7), capscrews (Figure 1, Item 8), and two universal joints (Figure 1, Item 9) from rear drive shaft assembly.
2. Remove lubrication fitting (Figure 1, Item 5) from each of two universal joints (Figure 1, Item 9).
3. Loosen cap (Figure 1, Item 10) and slide cap, two washers (Figure 1, Item 11), and washer (Figure 1, Item 12) back on splined yoke (Figure 1, Item 13).
4. Remove splined yoke (Figure 1, Item 13) from slip yoke (Figure 1, Item 14).
5. Remove two washers (Figure 1, Item 11), washer (Figure 1, Item 12), and cap (Figure 1, Item 10) from splined yoke (Figure 1, Item 13). Discard washers and cap.
6. Remove lubrication fitting (Figure 1, Item 6) from slip yoke (Figure 1, Item 14).

**END OF TASK****CLEANING****WARNING**

Solvent cleaning compound MIL-PRF-680 Type III is an environmentally compliant and low toxic material. However, it may be irritating to the eyes and skin. Use protective gloves and goggles. Use in well-ventilated areas. Keep away from open flames and other sources of ignition. Failure to do so may result in injury or death to personnel.

1. Clean two universal joints by wiping with a clean rag moistened with solvent cleaning compound. Dry with clean rag.
2. Clean all other parts with solvent cleaning compound. Dry thoroughly.

**END OF TASK****INSPECTION**

1. Inspect splined yoke, slip yoke, and two universal joints. Replace if cracked, bent, dented, or splines are twisted or broken. Remove any burrs with crocus cloth.
2. Inspect all other parts and mounting hardware. Replace if damaged, worn, or threads are damaged.

**END OF TASK**

**ASSEMBLY**

1. Install lubrication fitting (Figure 2, Item 6) on slip yoke (Figure 2, Item 14).
2. Position cap (Figure 2, Item 10), two new washers (Figure 2, Item 11), and new washer (Figure 2, Item 12) on splined yoke (Figure 2, Item 13).
3. Align splined yoke (Figure 2, Item 13) with slip yoke (Figure 2, Item 14) and install splined yoke in slip yoke.
4. Position two washers (Figure 2, Item 11), washer (Figure 2, Item 12), and cap (Figure 2, Item 10) against end of slip yoke (Figure 2, Item 14) and tighten cap.
5. Install lubrication fitting (Figure 2, Item 5) on each of two universal joints (Figure 2, Item 9).
6. Install two universal joints (Figure 2, Item 9) on rear drive shaft assembly with eight capscrews (Figure 2, Item 8) and nuts (Figure 2, Item 7).

**END OF TASK****INSTALLATION****WARNING**

Solvent cleaning compound MIL-PRF-680 Type III is an environmentally compliant and low toxic material. However, it may be irritating to the eyes and skin. Use protective gloves and goggles. Use in well-ventilated areas. Keep away from open flames and other sources of ignition. Failure to do so may result in injury or death to personnel.

1. At transmission output flange and at yoke rear axle differential, clean mounting surfaces by wiping with a clean rag moistened with solvent cleaning compound. Dry with a clean rag.
2. Push splined yoke (Figure 2, Item 13) into slip yoke (Figure 2, Item 14) and position rear drive shaft assembly on vehicle.
3. At transmission output flange, connect universal joint (Figure 2, Item 9) of slip yoke (Figure 2, Item 14) to transmission output flange with four capscrews (Figure 2, Item 2) and nuts (Figure 2, Item 1). Support splined yoke (Figure 2, Item 13). Tighten capscrews to 40 to 50 lb-ft (54 to 68 Nm).
4. At rear axle differential, connect other universal joint (Figure 2, Item 9) of splined yoke (Figure 2, Item 13) to yoke of rear axle differential with four capscrews (Figure 2, Item 4) and nuts (Figure 2, Item 3). Tighten capscrews to 40 to 50 lb-ft (54 to 68 Nm).
5. Lubricate two universal joints (Figure 2, Item 9) and slip yoke (Figure 2, Item 14) (refer to *Service* in this work package).

INSTALLATION - CONTINUED

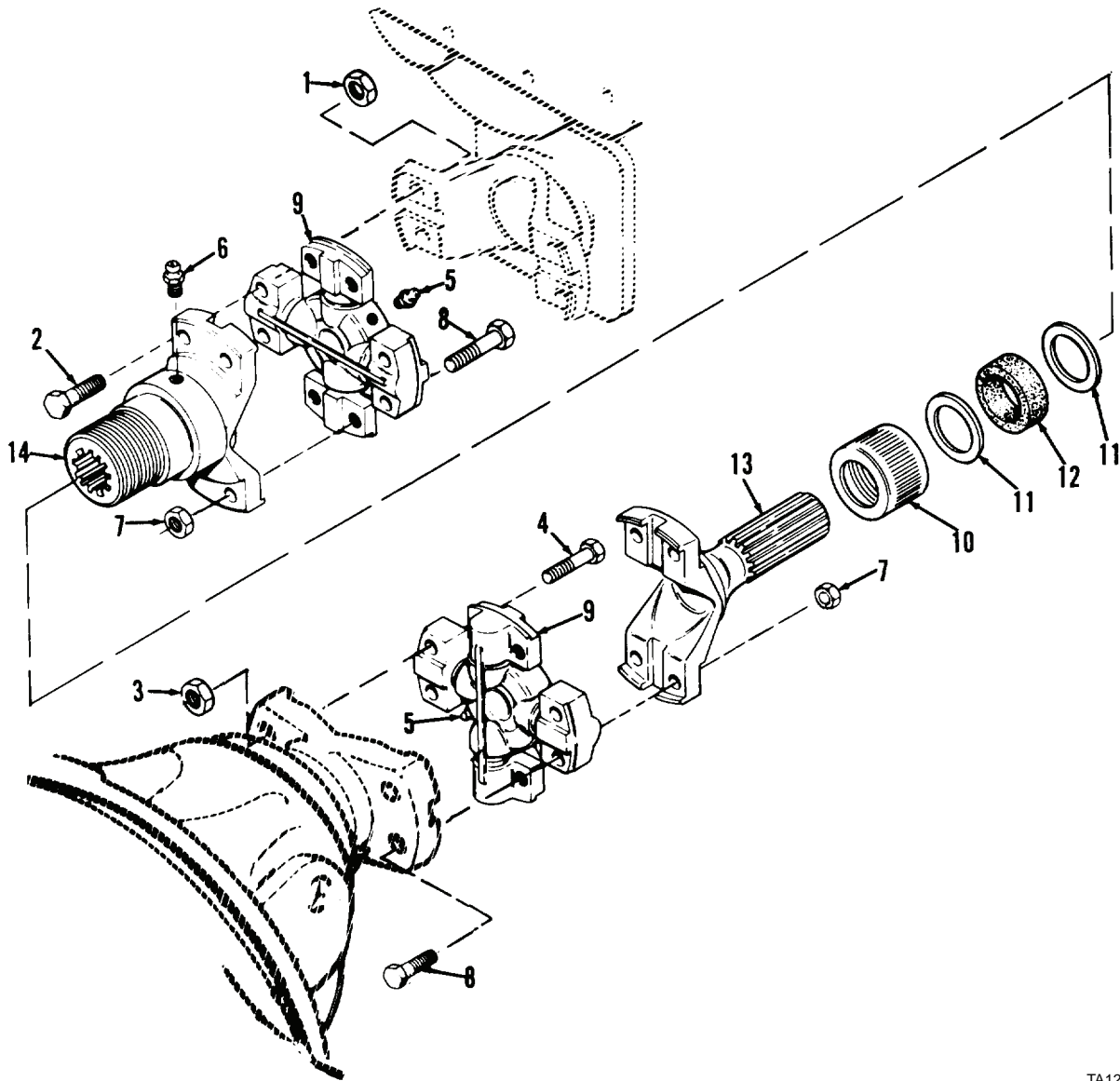

Figure 2. Rear Drive Shaft.

TA126971

END OF TASK

END OF WORK PACKAGE





---

# ORGANIZATIONAL MAINTENANCE INSTRUCTIONS

## FRONT AND REAR AXLES MAINTENANCE

### Inspection, Service

---

#### INITIAL SETUP

**Maintenance Level**

Organizational

**Tools and Special Tools**

Tool kit, general mechanic's (Item 15, WP 0309)

Shop equipment, common no. 1 (Item 2, WP 0309)

Container, 5-gal. capacity

**Materials/Parts**

Lubricating oil, gear (Item 22, WP 0310)

Rag, wiping (Item 26, WP 0310)

**References**

LO 10-3930-638-12

**Equipment Condition**

Engine OFF

Parking brake applied

---

**INSPECTION**

1. At each of four axle shaft flanges, inspect for lubricant leaks at axle shaft flange and at hub and drum assembly (Figure 1). Notify General Support Maintenance if leaks are found.

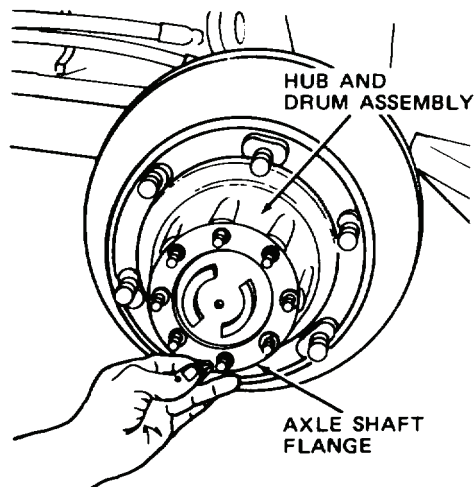

TA126972

**Figure 1. Axle Shaft.**

2. At each of two differential carriers, inspect for lubricant leaks at differential carrier and pinion shaft (Figure 2). Notify General Support Maintenance if leaks are found.
3. Inspect for leaks at drain plug and fill plug. Tighten drain plug and fill plug as necessary.

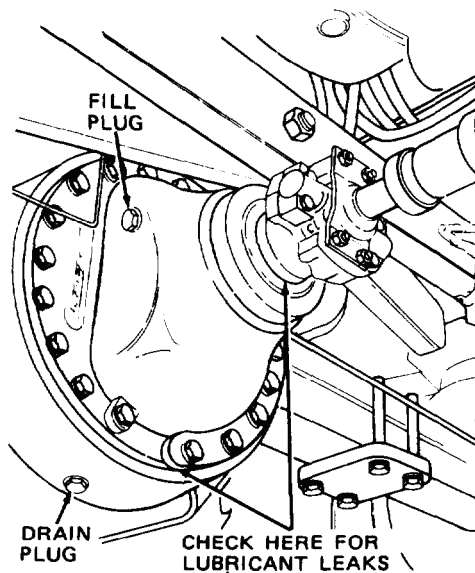

TA126973

**Figure 2. Axle Carrier.****END OF TASK**

**SERVICE****NOTE**

- Drive vehicle for 10 minutes to warm axle lubricant, park vehicle on level surface, apply parking brake, and turn engine OFF.
  - Clean drain plug, fill plug, and surrounding area before removing.
1. Place a 5-gal. (19-L) container under drain plug of differential carrier.
  2. Remove drain plug and allow gear lubricating oil to drain into container.
  3. Install drain plug.
  4. Remove fill plug and fill differential carrier to level of fill plug opening (LO 10-3930-638-12).
  5. Install fill plug.

**END OF TASK****END OF WORK PACKAGE**



## ORGANIZATIONAL MAINTENANCE INSTRUCTIONS

### FRONT AXLE AIR BREATHER REPLACEMENT

#### Removal, Cleaning, Inspection, Installation

#### INITIAL SETUP

##### Maintenance Level

Organizational

##### Tools and Special Tools

Tool kit, general mechanic's (Item 15, WP 0309)

Shop equipment, common no. 1 (Item 2, WP 0309)

##### Materials/Parts

Cleaning compound, solvent (Item 10, WP 0310)

##### Materials/Parts - Continued

Rag, wiping (Item 26, WP 0310)

##### Equipment Condition

Engine OFF

Parking brake applied

Noise baffle mat rod removed and mat positioned over instrument panel (WP 0187)

#### REMOVAL

At right side of hydraulic control valve, remove front axle air breather from fitting of axle breather hose (Figure 1).

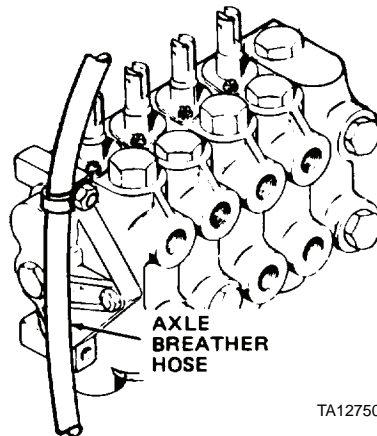

TA127500

Figure 1. Axle Breather Hose.

#### END OF TASK

**CLEANING****WARNING**

Solvent cleaning compound MIL-PRF-680 Type III is an environmentally compliant and low toxic material. However, it may be irritating to the eyes and skin. Use protective gloves and goggles. Use in well-ventilated areas. Keep away from open flames and other sources of ignition. Failure to do so may result in injury or death to personnel.

Clean front axle air breather by immersing breather in solvent cleaning compound. Dry thoroughly.

**END OF TASK****INSPECTION**

1. Inspect front axle air breather. Replace if clogged or damaged.
2. Inspect axle breather hose. Replace if cracked or deteriorated.

**END OF TASK****INSTALLATION**

Install front axle air breather on fitting of axle breather hose (Figure 2).

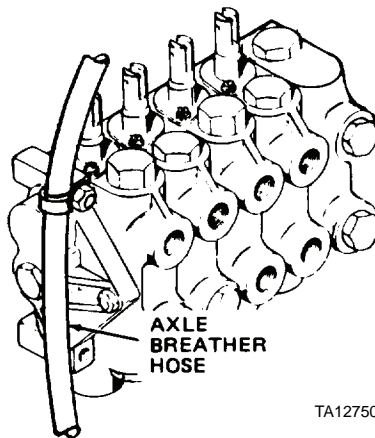

**Figure 2. Axle Breather Hose.**

**END OF TASK****END OF WORK PACKAGE**

# ORGANIZATIONAL MAINTENANCE INSTRUCTIONS

## REAR AXLE AIR BREATHER REPLACEMENT

### Removal, Cleaning, Inspection, Replacement

#### INITIAL SETUP

**Maintenance Level**

Organizational

**Tools and Special Tools**

Tool kit, general mechanic's (Item 15, WP 0309)

Shop equipment, common no. 1 (Item 2, WP 0309)

**Materials/Parts**

Cleaning compound, solvent (Item 10, WP 0310)

Rag, wiping (Item 26, WP 0310)

**Equipment Condition**

Left side panel removed (WP 0179)

#### REMOVAL

At left rear of engine, remove rear axle air breather from fitting of axle breather hose (Figure 1).

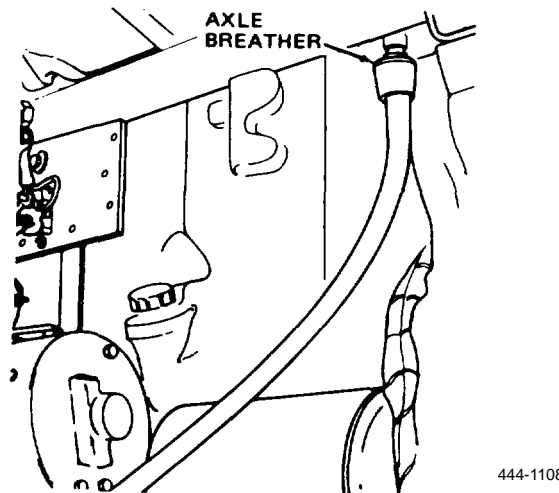

Figure 1. Rear Axle Air Breather.

#### END OF TASK

#### CLEANING



WARNING



Solvent cleaning compound MIL-PRF-680 Type III is an environmentally compliant and low toxic material. However, it may be irritating to the eyes and skin. Use protective gloves and goggles. Use in well-ventilated areas. Keep away from open flames and other sources of ignition. Failure to do so may result in injury or death to personnel.

Clean rear axle air breather by immersing breather in solvent cleaning compound. Dry thoroughly.

#### END OF TASK

**INSPECTION**

1. Inspect rear axle air breather. Replace if clogged or damaged.
2. Inspect axle breather hose. Replace if cracked or deteriorated.

**END OF TASK****INSTALLATION**

Install rear axle air breather on fitting of axle breather hose (Figure 2).

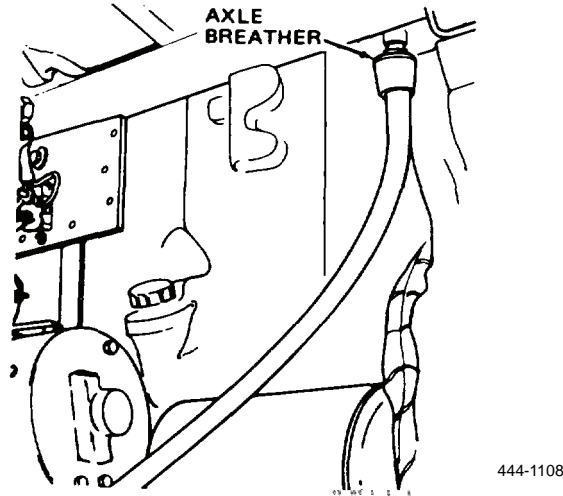

Figure 2. Rear Axle Air Breather.

**END OF TASK****END OF WORK PACKAGE**



---

## ORGANIZATIONAL MAINTENANCE INSTRUCTIONS

### FRONT AND REAR AXLE SHAFTS AND BEARINGS MAINTENANCE

Removal, Disassembly, Cleaning, Inspection, Assembly, Installation

---

#### INITIAL SETUP

##### Maintenance Level

Organizational

##### Tools and Special Tools

Tool kit, general mechanic's (Item 15, WP 0309)  
Shop equipment, common no. 1 (Item 2, WP 0309)  
Arbor press, 1/4-ton capacity  
Sleeve  
Wood blocks (2), 6 x 6 x 18 in.

##### Materials/Parts

Cleaning compound, solvent (Item 10, WP 0310)  
Grease, automotive and artillery (Item 17, WP 0310)  
Rag, wiping (Item 26, WP 0310)

##### Materials/Parts - Continued

Gasket  
Lockwasher (14)  
Oil seal

##### References

WP 0163  
WP 0169

##### Equipment Condition

Vehicle parked on level surface  
Engine OFF  
Parking brake applied  
Wheels blocked  
Shipping lock pin installed (WP 0044)

---

**REMOVAL****WARNING**

- Before raising vehicle from ground, ensure shipping lock pin is installed. Failure to follow this warning may cause vehicle to turn and slip off jacks or jack stands, causing injury or death to personnel.
- Tire and wheel assembly must be removed before removing axle shaft and hub and drum assembly to avoid damaging axle oil seal. Damage to seal can result in contamination of brake linings and brake failure. Failure to follow this warning may cause injury or death to personnel.

**NOTE**

Each of four axle shafts and bearings is removed the same way.

1. Remove tire and wheel assembly from end of axle (WP 0169).
2. Remove eight nuts (Figure 1, Item 1), lockwashers (Figure 1, Item 2), and tapered dowels (Figure 1, Item 3). Discard lockwashers.

**NOTE**

Left and right axle shafts are different lengths. Mark axle shafts before removing.

3. Remove axle shaft (Figure 1, Item 4) and gasket (Figure 1, Item 5) from axle. Discard gasket.

**NOTE**

If hub and drum assembly is hard to remove, back off brake shoe adjustment (WP 0163).

4. Bend tab of lock (Figure 1, Item 7) to flat position and remove outer wheel bearing nut (Figure 1, Item 6), lock, inner wheel bearing nut (Figure 1, Item 8), thrust washer (Figure 1, Item 9), outer wheel bearing (Figure 1, Item 10), and hub and drum assembly (Figure 1, Item 11).
5. Remove oil seal (Figure 1, Item 15) and inner wheel bearing (Figure 1, Item 16). Discard oil seal.

**END OF TASK****DISASSEMBLY**

1. From inside drum (Figure 1, Item 14), remove six nuts (Figure 1, Item 12) and lockwashers (Figure 1, Item 13) from wheel studs (Figure 1, Item 19). Discard lockwashers.
2. Remove hub (Figure 1, Item 21) from drum (Figure 1, Item 14).

**NOTE**

Do not perform the following steps unless bearing cups or hub requires replacement.

3. Use arbor press and proper size sleeve to remove inner bearing cup (Figure 1, Item 17) and outer bearing cup (Figure 1, Item 18) from hub (Figure 1, Item 21).
4. Remove six wheel studs (Figure 1, Item 19) from hub (Figure 1, Item 21).
5. Remove eight studs (Figure 1, Item 20) from hub (Figure 1, Item 21).

DISASSEMBLY - CONTINUED

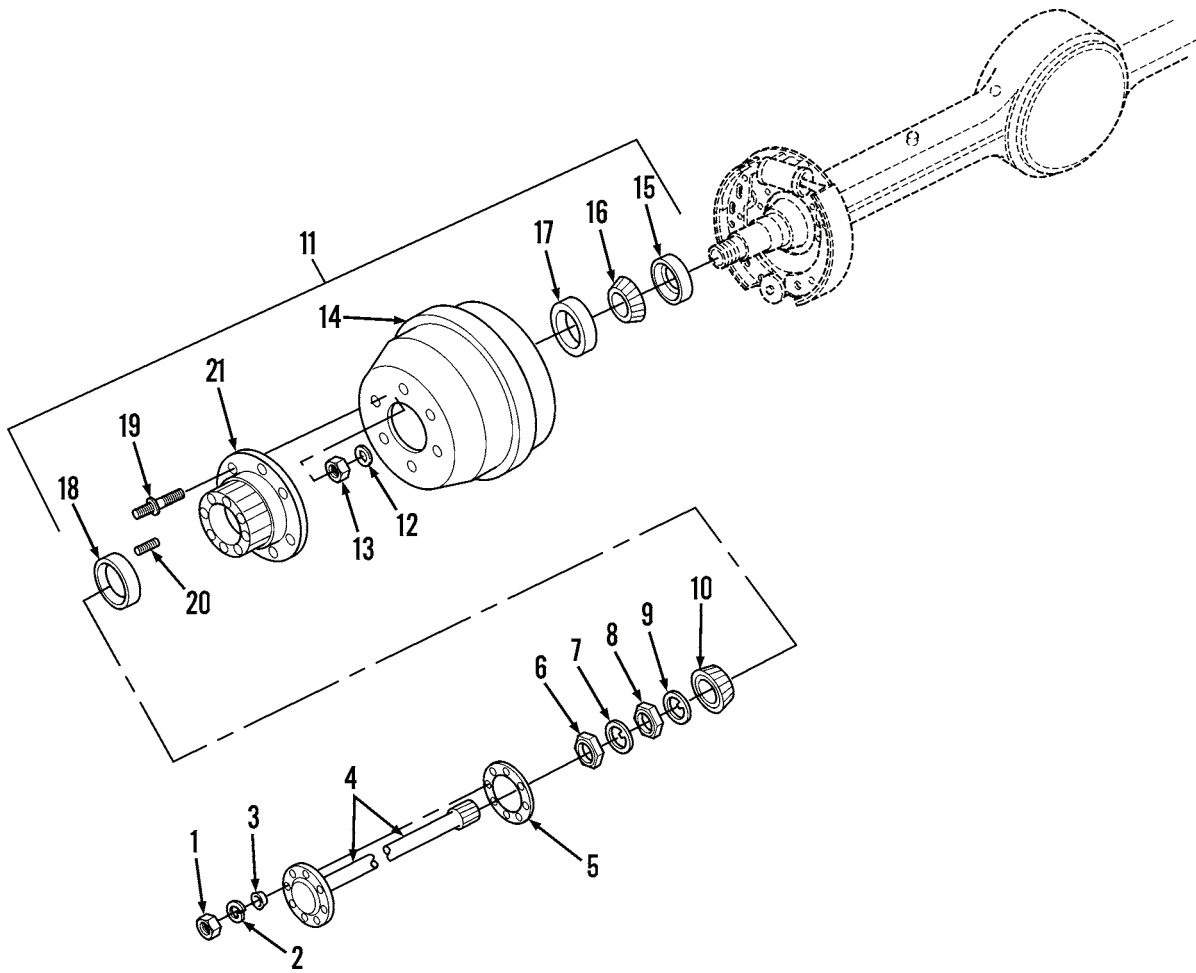

444-1105A

Figure 1. Front and Rear Axle Shafts and Bearings.

END OF TASK

**CLEANING****WARNING**

Solvent cleaning compound MIL-PRF-680 Type III is an environmentally compliant and low toxic material. However, it may be irritating to the eyes and skin. Use protective gloves and goggles. Use in well-ventilated areas. Keep away from open flames and other sources of ignition. Failure to do so may result in injury or death to personnel.

1. Clean outer wheel bearing (Figure 2, Item 10) and inner wheel bearing (Figure 2, Item 16) with solvent cleaning compound. Allow to air dry.
2. Clean all other parts with solvent cleaning compound. Dry thoroughly.

**END OF TASK****INSPECTION****NOTE**

If any bearing is to be replaced, the bearing cup for that bearing must also be replaced.

1. Inspect outer wheel bearing (Figure 2, Item 10) and inner wheel bearing (Figure 2, Item 16). Replace if worn, pitted, or damaged.
2. Inspect axle shaft (Figure 2, Item 4). Replace if bent, twisted, or splines are damaged.
3. Inspect brake drum (Figure 2, Item 14). Replace if cracked, scored, or worn.
4. Inspect hub (Figure 2, Item 21). Replace if cracked or damaged.
5. Inspect all other parts. Replace if bent, damaged, or distorted.

INSPECTION - CONTINUED

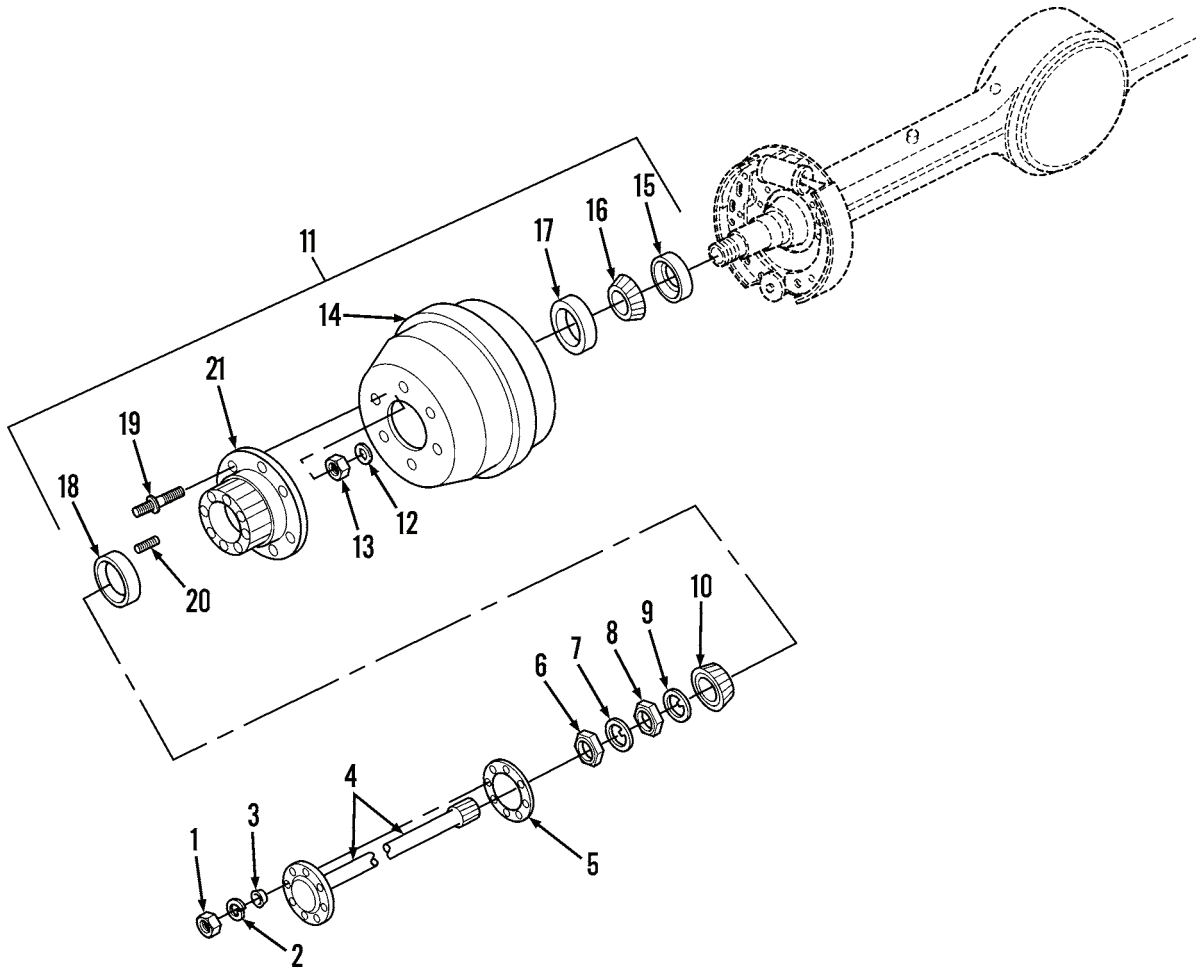

444-1105A

Figure 2. Front and Rear Axle Shafts and Bearings.

END OF TASK

---

**ASSEMBLY**

1. Install eight studs (Figure 3, Item 20) on hub (Figure 3, Item 21).
2. Install six wheel studs (Figure 3, Item 19) on hub (Figure 3, Item 21).
3. Use arbor press and proper size sleeve to install outer bearing cup (Figure 3, Item 18) and inner bearing cup (Figure 3, Item 17) on hub (Figure 3, Item 21), if removed.
4. Position hub (Figure 3, Item 21) in drum (Figure 3, Item 14).
5. At inside of drum (Figure 3, Item 14), install six new lockwashers (Figure 3, Item 13) and nuts (Figure 3, Item 12) on wheel studs (Figure 3, Item 19).

**END OF TASK****INSTALLATION**

1. Apply grease to inside of hub (Figure 3, Item 21), inner bearing cup (Figure 3, Item 17), outer bearing cup (Figure 3, Item 18), inner wheel bearing (Figure 3, Item 16), and outer wheel bearing (Figure 3, Item 10).
2. Use hammer and punch to install new oil seal (Figure 3, Item 15) and install inner wheel bearing (Figure 3, Item 16).
3. At end of axle, position hub and drum assembly (Figure 3, Item 11), outer wheel bearing (Figure 3, Item 10), thrust washer (Figure 3, Item 9), and inner wheel bearing nut (Figure 3, Item 8).
4. Tighten inner wheel bearing nut (Figure 3, Item 8) to 50 lb-ft (68 Nm). Rotate hub and drum assembly (Figure 3, Item 11) back and forth several revolutions. Tighten nut to same torque, then back off nut 1/6 to 1/4 turn.
5. Install lock (Figure 3, Item 7) and outer wheel bearing nut (Figure 3, Item 6). Tighten nut to 250 to 400 lb-ft (339 to 542 Nm). Bend tab of lock over one flat of nut.
6. Position new gasket (Figure 3, Item 5) and axle shaft (Figure 3, Item 4) in axle.
7. Install eight tapered dowels (Figure 3, Item 3), new lockwashers (Figure 3, Item 2), and nuts (Figure 3, Item 1).

INSTALLATION - CONTINUED

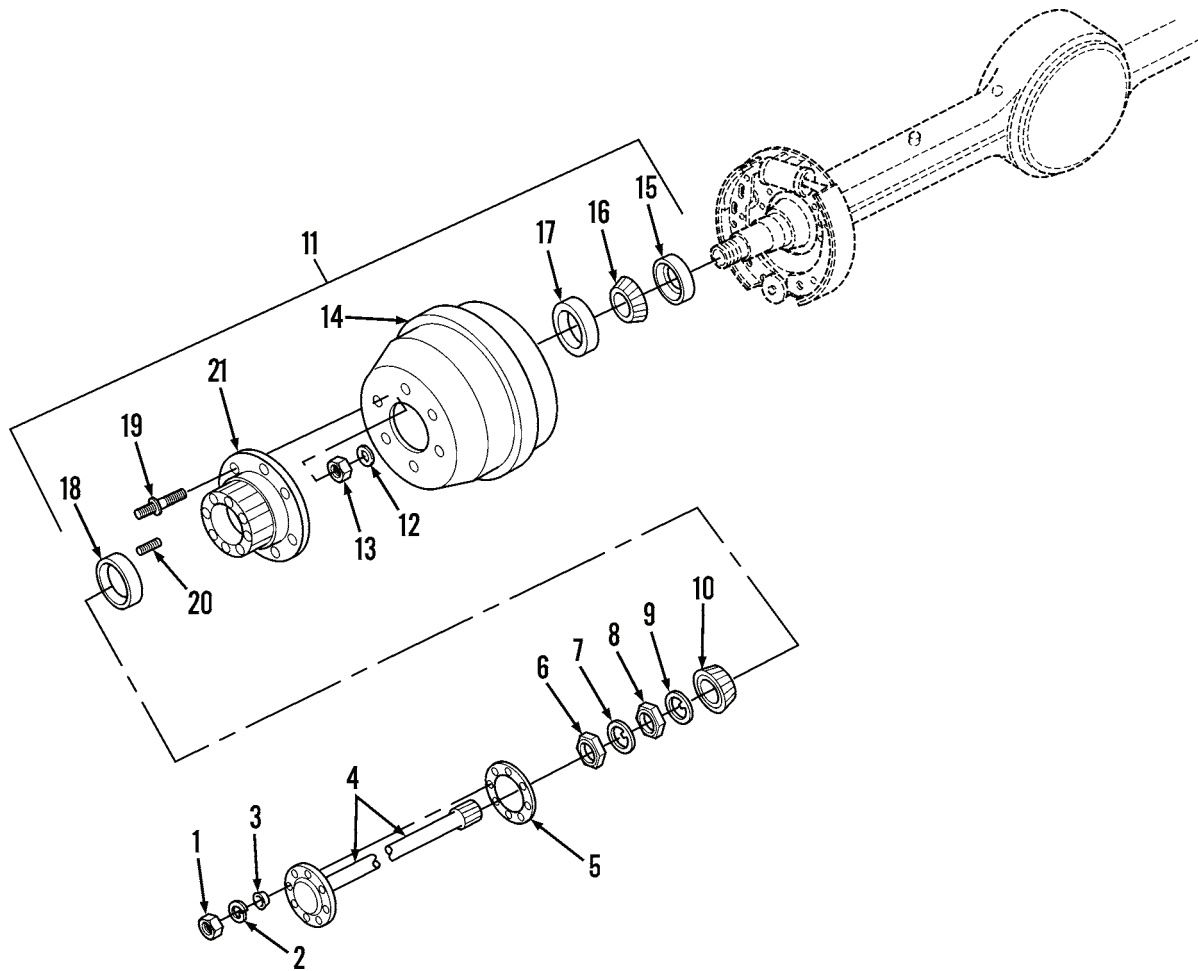

444-1105A

Figure 3. Front and Rear Axle Shafts and Bearings.

8. Install tire and wheel assembly (WP 0169).

**END OF TASK**

**END OF WORK PACKAGE**





---

## ORGANIZATIONAL MAINTENANCE INSTRUCTIONS

### PARKING BRAKE LINKAGE MAINTENANCE

Inspection, Removal, Cleaning, Inspection/Repair, Installation/Replacement, Adjustment

---

#### INITIAL SETUP

##### Maintenance Level

Organizational

##### Tools and Special Tools

Tool kit, general mechanic's (Item 15, WP 0309)

Shop equipment, common no. 1 (Item 2, WP 0309)

##### Materials/Parts

Cleaning compound, solvent (Item 10, WP 0310)

Diesel fuel, arctic (Item 14, WP 0310)

##### Materials/Parts - Continued

Diesel fuel, DF-2 (Item 15, WP 0310)

Rag, wiping (Item 26, WP 0310)

Cotter pin (2)

Lockwasher (5)

##### Equipment Condition

Vehicle parked on level surface

Vehicle turned (articulated) left

Engine OFF

Parking brake lever released

---

**INSPECTION**

1. Inspect parking brake lever (Figure 1, Item 4) for loose or missing hardware. Tighten loose hardware; replace missing hardware.
2. Inspect parking brake cable (Figure 1, Item 8) for loose or missing hardware. Tighten loose hardware; replace missing hardware.
3. Apply parking brake lever (Figure 1, Item 4). If linkage seems too loose as indicated by lever moving too freely, adjust as described in *Adjustment*, step 1, in this work package.

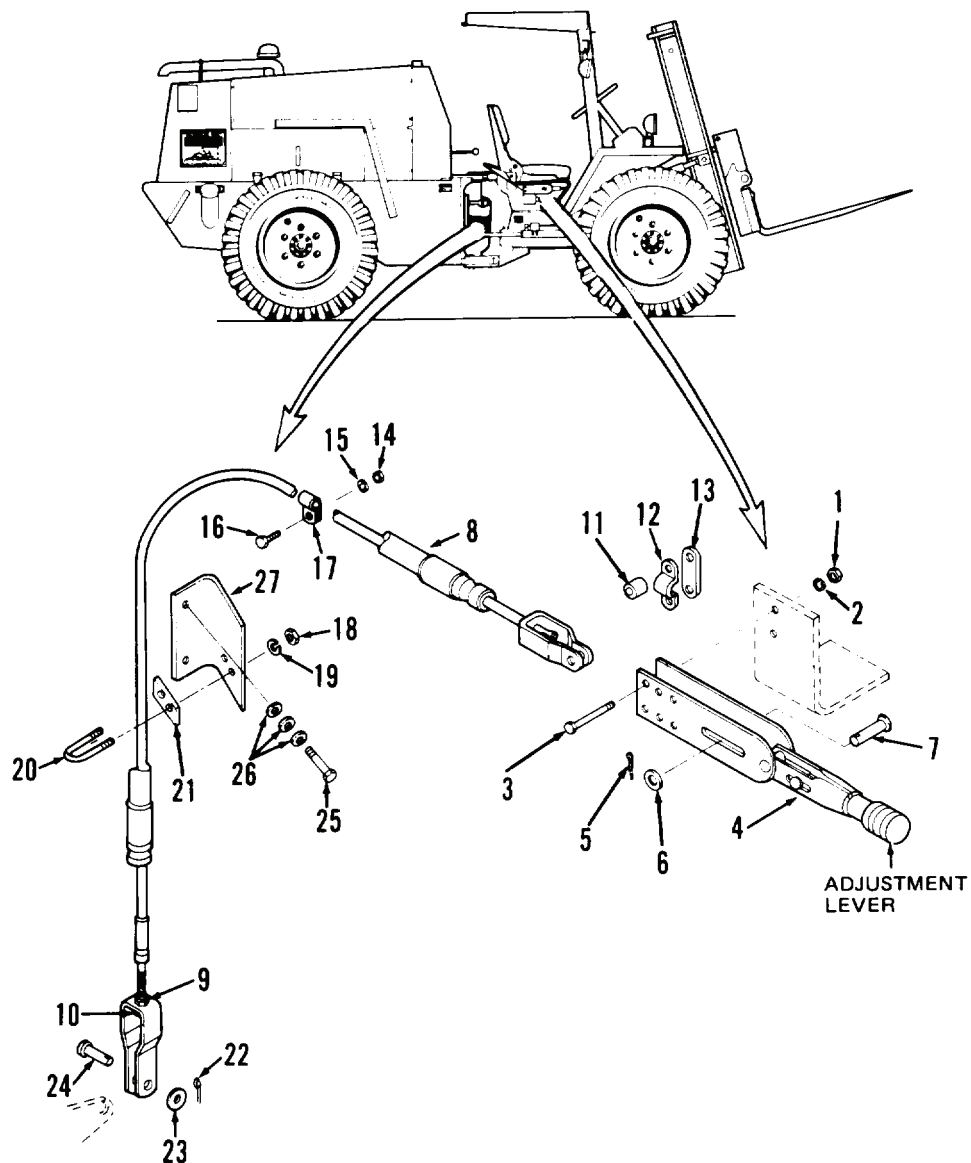

TA126988

Figure 1. Parking Brake Linkage.

**END OF TASK**

**REMOVAL**

1. In operator's compartment, remove two nuts (Figure 1, Item 1) and lockwashers (Figure 1, Item 2). Discard lockwashers.
2. Remove two capscrews (Figure 1, Item 3) from parking brake lever (Figure 1, Item 4).
3. Remove parking brake lever (Figure 1, Item 4) from vehicle.
4. Remove cotter pin (Figure 1, Item 5) from pin (Figure 1, Item 7). Discard cotter pin.
5. Remove washer (Figure 1, Item 6) from pin (Figure 1, Item 7).
6. Remove pin (Figure 1, Item 7) from vehicle to disconnect parking brake cable (Figure 1, Item 8) clevis from parking brake lever (Figure 1, Item 4).
7. Disengage parking brake cable (Figure 1, Item 8) from parking brake lever (Figure 1, Item 4).
8. Remove two spacers (Figure 1, Item 11), clamp (Figure 1, Item 12), and clamp spacer (Figure 1, Item 13).
9. Remove nut (Figure 1, Item 14), lockwasher (Figure 1, Item 15), capscrew (Figure 1, Item 16), and clamp (Figure 1, Item 17). Discard lockwasher.
10. Remove two nuts (Figure 1, Item 18), lockwashers (Figure 1, Item 19), and U-bolt (Figure 1, Item 20) from vehicle. Discard lockwashers.
11. Position parking brake cable (Figure 1, Item 8) aside.
12. Remove plate (Figure 1, Item 21) from vehicle.
13. Remove cotter pin (Figure 1, Item 22) from clevis pin (Figure 1, Item 24). Discard cotter pin.
14. Remove washer (Figure 1, Item 23) and clevis pin (Figure 1, Item 24) from adjusting nut (Figure 1, Item 9) to disconnect parking brake cable (Figure 1, Item 8) clevis (Figure 1, Item 10) from actuating lever.
15. Remove parking brake cable (Figure 1, Item 8) from vehicle.

**NOTE**

Do not perform the following steps unless bracket requires replacement.

16. At transmission, left side, above parking brake, remove two capscrews (Figure 1, Item 25) and six washers (Figure 1, Item 26) from bracket (Figure 1, Item 27).
17. Remove bracket (Figure 1, Item 27) from vehicle.

**END OF TASK****CLEANING****WARNING**

- DO NOT smoke or permit any open flame in area of machine while you are handling fuel. Wear fuel-resistant gloves. If exposed to fuel, promptly wash exposed skin and change fuel-soaked clothing. Failure to follow this warning may result in injury to personnel.
- Solvent cleaning compound MIL-PRF-680 Type III is an environmentally compliant and low toxic material. However, it may be irritating to the eyes and skin. Use protective gloves and goggles. Use in well-ventilated areas. Keep away from open flames and other sources of ignition. Failure to do so may result in injury or death to personnel.

1. Use clean diesel fuel to clean parking brake cable (Figure 1, Item 8).
2. Use solvent cleaning compound to clean all other parts.

**END OF TASK**

**INSPECTION/REPAIR**

1. Inspect parking brake lever (Figure 2, Item 4). Replace if dented, bent, or lever action is rough.
2. Inspect parking brake cable (Figure 2, Item 8). Replace if clevis mounting holes elongated, or if cable kinked or threads damaged.
3. Inspect all other parts. Replace if damaged, worn, bent, distorted, or threads damaged.

**END OF TASK****INSTALLATION/REPLACEMENT**

1. At transmission, left side, above parking brake, position bracket (Figure 2, Item 27) on transmission rear cover.
2. Install six washers (Figure 2, Item 26) and two capscrews (Figure 2, Item 25). Place three washers on each capscrew and tighten capscrews to 37 to 41 lb-ft (50 to 56 Nm).
3. Loosen adjusting nut (Figure 2, Item 9) on parking brake cable (Figure 2, Item 8) until just held onto cable by three or four threads.
4. Adjust adjusting nut (Figure 2, Item 9) until it just touches top of clevis (Figure 2, Item 10).
5. Position clevis (Figure 2, Item 10) on actuating lever and align holes.
6. Install clevis pin (Figure 2, Item 24) on adjusting nut (Figure 2, Item 9) and connect parking brake cable (Figure 2, Item 8) clevis (Figure 2, Item 10) to actuating lever.
7. Position washer (Figure 2, Item 23) on clevis pin (Figure 2, Item 24) and install new cotter pin (Figure 2, Item 22).
8. Position plate (Figure 2, Item 21) between parking brake cable (Figure 2, Item 8) and bracket (Figure 2, Item 27).
9. Install U-bolt (Figure 2, Item 20) to secure parking brake cable (Figure 2, Item 8) and plate (Figure 2, Item 21).
10. Install two new lockwashers (Figure 2, Item 19) and nuts (Figure 2, Item 18) on U-bolt (Figure 2, Item 20).
11. Position clamp (Figure 2, Item 17) on parking brake cable (Figure 2, Item 8).
12. Install capscrew (Figure 2, Item 16), new lockwasher (Figure 2, Item 15), and nut (Figure 2, Item 14).
13. Position parking brake cable (Figure 2, Item 8) clevis in parking brake lever (Figure 2, Item 4) and align holes in clevis and lever.
14. Install pin (Figure 2, Item 7) in parking brake lever (Figure 2, Item 4).
15. Install washer (Figure 2, Item 6) and new cotter pin (Figure 2, Item 5).
16. Install capscrew (Figure 2, Item 3) in parking brake lever (Figure 2, Item 4) just far enough to install two spacers (Figure 2, Item 11) on capscrew.
17. Install two spacers (Figure 2, Item 11) on capscrew (Figure 2, Item 3).
18. Install clamp (Figure 2, Item 12) and clamp spacer (Figure 2, Item 13) on parking brake cable (Figure 2, Item 8), then install in parking brake lever (Figure 2, Item 4) and threading capscrew (Figure 2, Item 3) through spacer (Figure 2, Item 11), clamp, and clamp spacer.
19. In operator's compartment, position parking brake lever (Figure 2, Item 4) and install two new lockwashers (Figure 2, Item 2), capscrews (Figure 2, Item 3), and nuts (Figure 2, Item 1).

**END OF TASK****ADJUSTMENT**

1. In operator's compartment, adjust parking brake lever (Figure 2, Item 4): With lever in released position, turn adjustment knob located on top of lever fully counterclockwise until it no longer can be turned.

**NOTE**

Be sure you do not have parking brake lever in applied position (horizontal) when performing the following step.

2. Adjust adjusting nut (Figure 2, Item 9) on transmission parking brake actuating lever. Thread fully.
3. Adjust adjusting nut (Figure 2, Item 9) upwards until all slack is removed from parking brake cable (Figure 2, Item 8).
4. Tighten adjusting nut (Figure 2, Item 9) against parking brake cable (Figure 2, Item 8) clevis (Figure 2, Item 10).
5. In operator's compartment, adjust parking brake lever (Figure 2, Item 4). Turn knob located on top of lever clockwise. Apply parking brake; if considerable force is required to pull lever up, back off parking brake lever adjustment knob.

ADJUSTMENT - CONTINUED

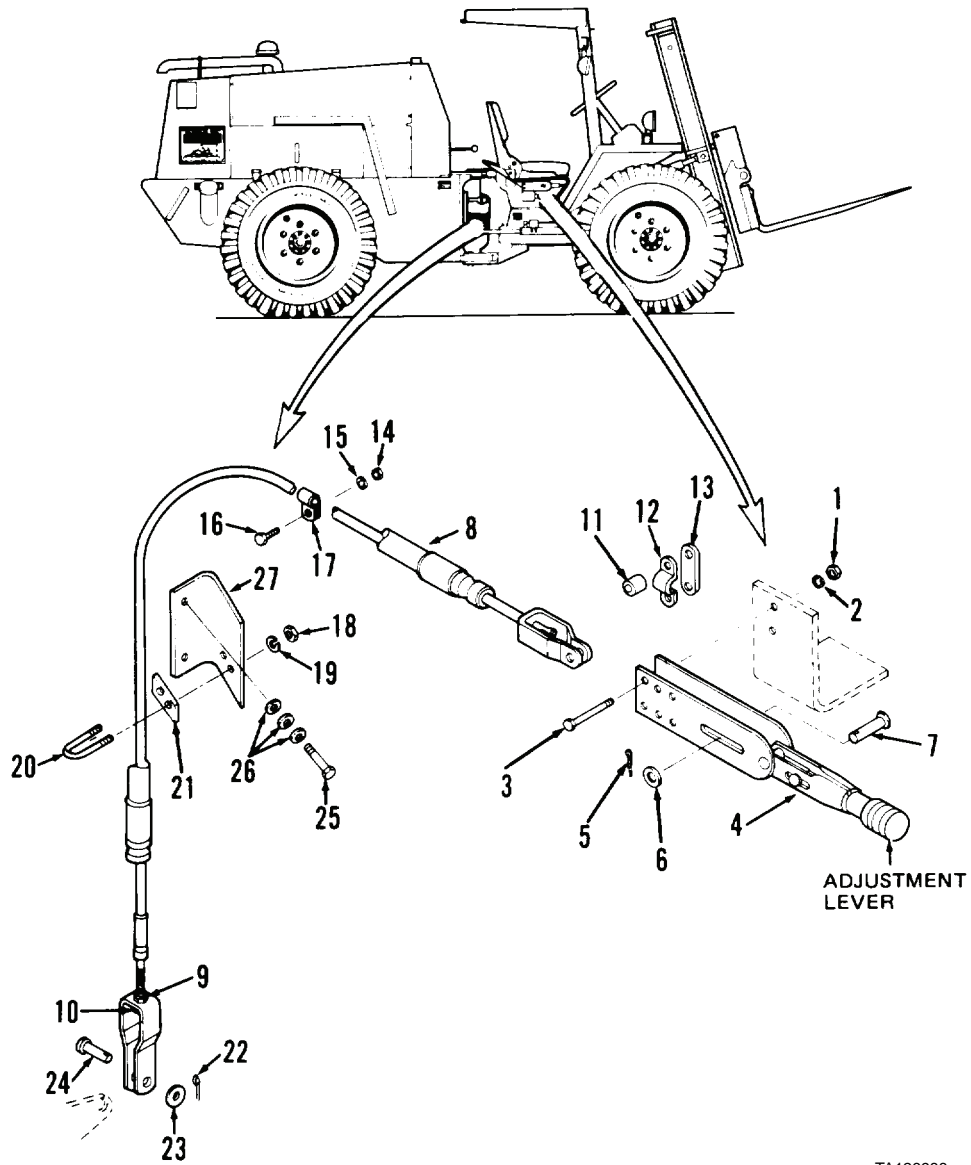

TA126988

Figure 2. Parking Brake Linkage.

END OF TASK

END OF WORK PACKAGE



---

## ORGANIZATIONAL MAINTENANCE INSTRUCTIONS

### PARKING BRAKE MAINTENANCE

Inspection, Removal, Cleaning, Post-Removal Inspection, Repair, Installation/Replacement

---

#### INITIAL SETUP

##### Maintenance Level

Organizational

##### Tools and Special Tools

Tool kit, general mechanic's (Item 15, WP 0309)

Shop equipment, common no. 1 (Item 2, WP 0309)

Hand vacuum cleaner

Wood blocks (2), 6 x 6 x 18 in.

##### Materials/Parts

Cleaning compound, solvent (Item 10, WP 0310)

Rag, wiping (Item 26, WP 0310)

Brake lining and rivet kit

##### Materials/Parts - Continued

Lockwasher (16)

Rivet

Seal

##### Equipment Condition

Engine OFF

Vehicle parked on level surface with wheels blocked

Transmission direction selector lever in neutral (N) position

Parking brake linkage disconnected from parking brake lever cam (WP 0161)

Center drive shaft assembly removed (WP 0155)

---

## NOTE

To perform inspection procedure, it is not necessary to disconnect parking brake linkage or remove center drive shaft assembly.

### INSPECTION

1. Remove six capscrews (Figure 1, Item 1) and lockwashers (Figure 1, Item 2) from brake drum (Figure 1, Item 3). Discard lockwashers.
2. Position brake drum (Figure 1, Item 3) over center drive shaft.
3. Inspect shoe and lining (Figure 1, Item 9). Replace if less than 1/8 in. (3 mm) thick in any area.
4. Inspect brake drum (Figure 1, Item 3). Replace if cracked or scored.

## NOTE

If shoe and lining or brake drum require replacement, remove center drive shaft (WP 0155) and disconnect linkage from parking brake lever cam (WP 0161). Proceed to step 5. If shoe and lining and brake drum are okay, proceed to *Removal* in this work package.

5. Position brake drum (Figure 1, Item 3) on brake flange (Figure 1, Item 7).
6. Install six new lockwashers (Figure 1, Item 2) and capscrews (Figure 1, Item 1). Tighten capscrews to 41 to 49 lb-ft (56 to 66 Nm).

### END OF TASK

### REMOVAL

1. Support brake drum (Figure 1, Item 3) and remove six capscrews (Figure 1, Item 1) and lockwashers (Figure 1, Item 2). Discard lockwashers.
2. Pull and remove brake drum (Figure 1, Item 3) from brake flange (Figure 1, Item 7).

## NOTE

Use impact wrench. If impact wrench is not available, use retainer bar to prevent flange from turning while loosening nut.

3. Remove nut (Figure 1, Item 4), washer (Figure 1, Item 5), and seal (Figure 1, Item 6). Discard seal (Figure 1, Item 6).
4. Pull and remove brake flange (Figure 1, Item 7) from transmission output shaft.
5. Support brake shoes (Figure 1, Item 9) and remove two return springs (Figure 1, Item 8).
6. Pull and remove shoe and lining (Figure 1, Item 9) and actuating lever (Figure 1, Item 10) from backing plate (Figure 1, Item 13).

## NOTE

Remove capscrews, lockwashers, and backing plate only if necessary for replacement.

7. Support backing plate (Figure 1, Item 13) and remove four capscrews (Figure 1, Item 11) and lockwashers (Figure 1, Item 12). Discard lockwashers.
8. Remove backing plate (Figure 1, Item 13) and four spacers (Figure 1, Item 14).



REMOVAL - CONTINUED

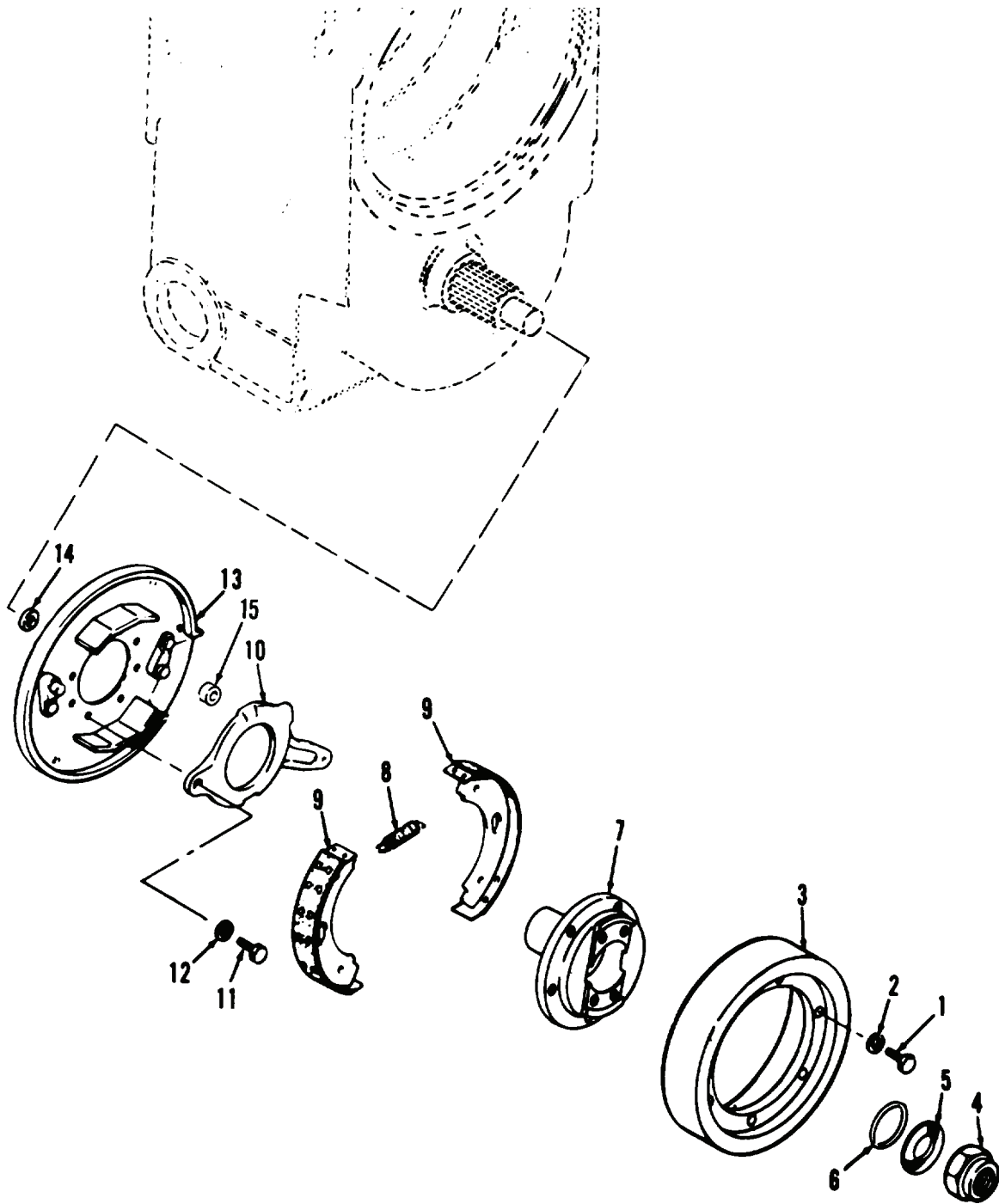

TA502381

Figure 1. Parking Brake Assembly.

END OF TASK

## CLEANING

1. Use hand vacuum cleaner to remove dust and clean brake drum (Figure 2, Item 3), shoe and lining (Figure 2, Item 9), and backing plate (Figure 2, Item 13).



**WARNING**

- Solvent cleaning compound MIL-PRF-680 Type III is an environmentally compliant and low toxic material. However, it may be irritating to the eyes and skin. Use protective gloves and goggles. Use in well-ventilated areas. Keep away from open flames and other sources of ignition. Failure to do so may result in injury or death to personnel.
  - Particles blown by compressed air are hazardous. DO NOT exceed 15 PSI (103 kPa) nozzle pressure when drying parts with compressed air. DO NOT direct compressed air against human skin. Make sure air stream is directed away from user and other personnel in the area. To prevent injury, user must wear protective goggles or face shield. Failure to follow this warning may result in injury to personnel.
2. Use solvent cleaning compound to clean brake drum (Figure 2, Item 3), brake flange (Figure 2, Item 7), return springs (Figure 2, Item 8), actuating lever (Figure 2, Item 10), backing plate (Figure 2, Item 13), and all hardware. Dry thoroughly with compressed air.

## END OF TASK

### POST - REMOVAL INSPECTION

1. Inspect brake drum (Figure 2, Item 3). Replace if cracked, scored, or excessively worn.
2. Inspect shoe and lining (Figure 2, Item 9). Repair if linings scored, cracked, deteriorated, or excessively worn. Replace if brake shoe cracked, or if pawl holes or lever contact areas excessively worn.
3. Inspect return springs (Figure 2, Item 8). Replace if coils broken, or if distorted or stretched.
4. Inspect brake flange (Figure 2, Item 7). Replace if cracked, or if spline teeth burred, chipped, or excessively worn.
5. Inspect actuating lever (Figure 2, Item 10). Replace if cracked or distorted, or if roller out-of-round or excessively worn.
6. Inspect backing plate (Figure 2, Item 13). Replace if cracked, or if pivot points (pawls) excessively worn.
7. Inspect all hardware. Replace if cracked, worn, or if threads damaged.

POST - REMOVAL INSPECTION - CONTINUED

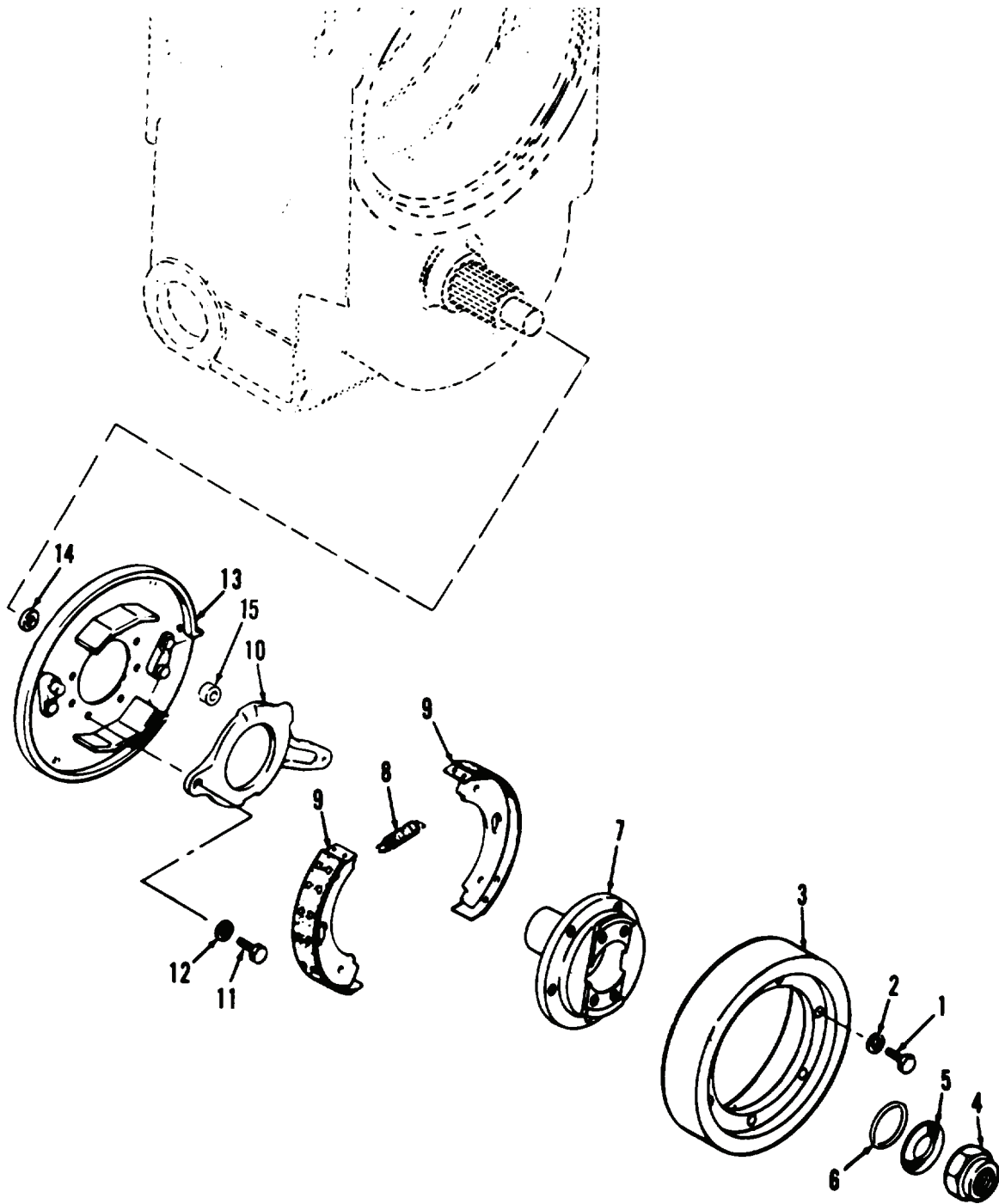

TA502381

Figure 2. Parking Brake Assembly.

END OF TASK

## REPAIR

1. Remove 10 rivets from brake shoe and lining (Figure 3). Cut or drill from brake lining and shoe.

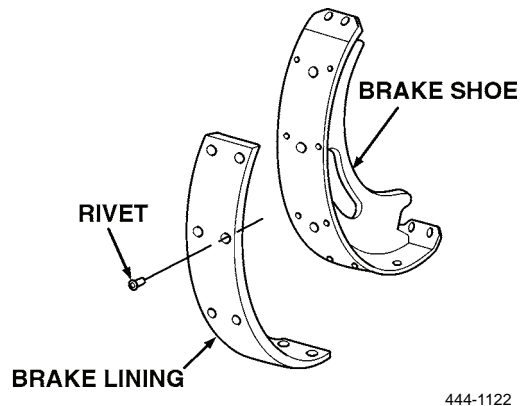

Figure 3. Brake Shoe and Lining.



- Solvent cleaning compound MIL-PRF-680 Type III is an environmentally compliant and low toxic material. However, it may be irritating to the eyes and skin. Use protective gloves and goggles. Use in well-ventilated areas. Keep away from open flames and other sources of ignition. Failure to do so may result in injury or death to personnel.
  - Particles blown by compressed air are hazardous. DO NOT exceed 15 PSI (103 kPa) nozzle pressure when drying parts with compressed air. DO NOT direct compressed air against human skin. Make sure air stream is directed away from user and other personnel in the area. To prevent injury, user must wear protective goggles or face shield. Failure to follow this warning may result in injury to personnel.
2. Remove and clean brake shoe. Use solvent cleaning compound on shoe contact face. Dry thoroughly with compressed air.
  3. Position and clamp new brake lining. Clamp lining to shoe with C-clamps so rivet holes are in alignment.
  4. Install 10 new rivets. Drive squarely into rivet holes with flat head drift.

## NOTE

Make certain lining is firmly clamped to brake shoe, locating C-clamps as close to rivet holes as possible.

5. Form rivet heads. Using rivet set, start on center rivets and move outwards toward sides and ends of lining.

## END OF TASK

## INSTALLATION/REPLACEMENT

1. At transmission rear, position four spacers (Figure 4, Item 14) on backing plate (Figure 4, Item 13).
2. Position backing plate (Figure 4, Item 13) on transmission.
3. Install four new lockwashers (Figure 4, Item 12) and capscrews (Figure 4, Item 11). Tighten capscrews to 81 to 97 lb-ft (110 to 132 Nm).
4. Position actuating lever (Figure 4, Item 10) on backing plate pawls.
5. Position shoe and lining (Figure 4, Item 9) on backing plate pawls.

**INSTALLATION/REPLACEMENT - CONTINUED**

6. Install two return springs (Figure 4, Item 8) on brake shoes (Figure 4, Item 9); top spring in inner holes on shoes; bottom spring in center holes on shoes.
7. Install brake flange (Figure 4, Item 7) on transmission output shaft.

**NOTE**

Use impact wrench to tighten nut. If impact wrench is not available, temporarily install two bolts in brake flange, and insert retainer bar between bolts to prevent flange from turning while tightening nut.

8. Install new seal (Figure 4, Item 6), washer (Figure 4, Item 5), and nut (Figure 4, Item 4). Tighten nut to 600 to 700 lb-ft (813 to 949 Nm).

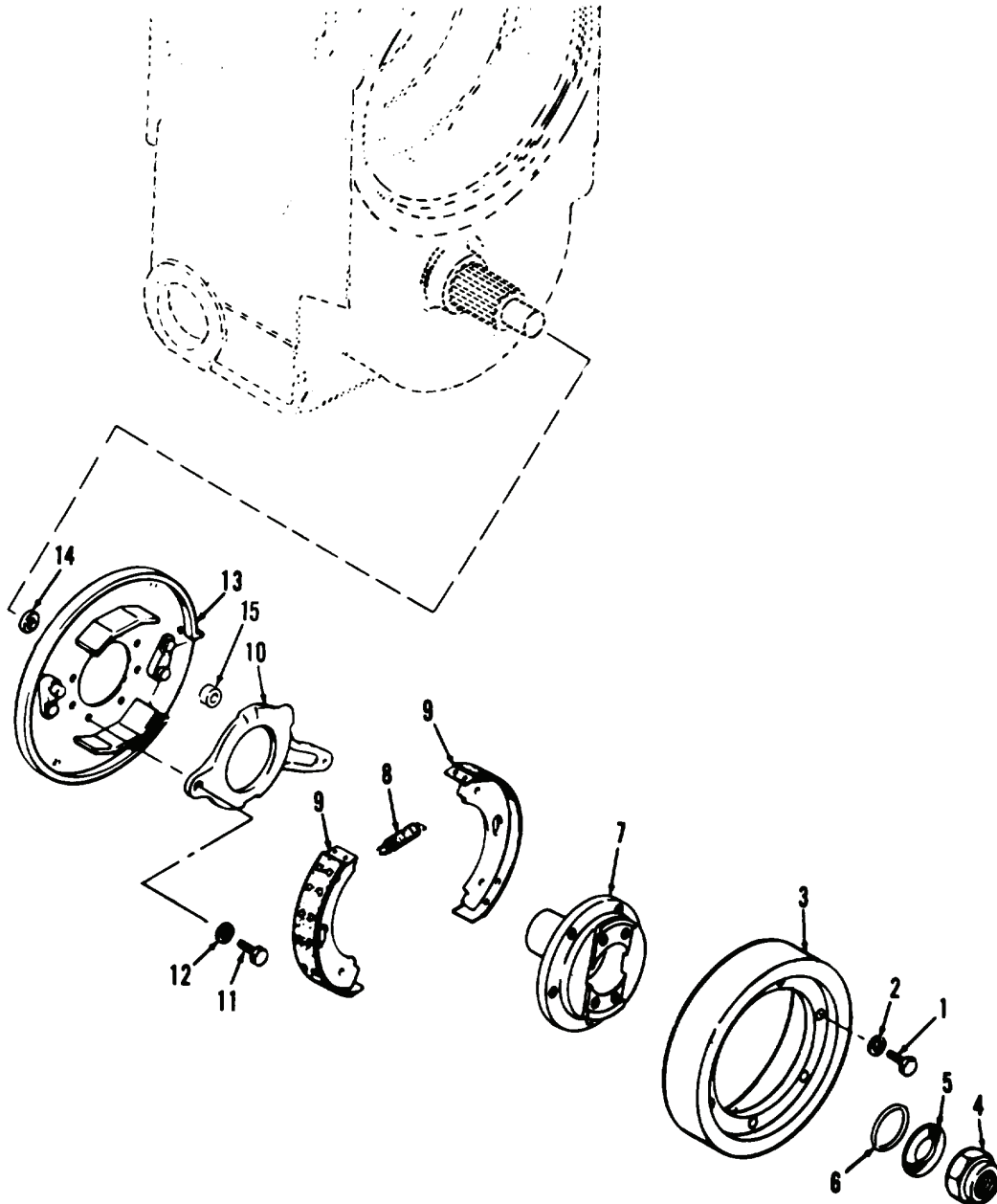
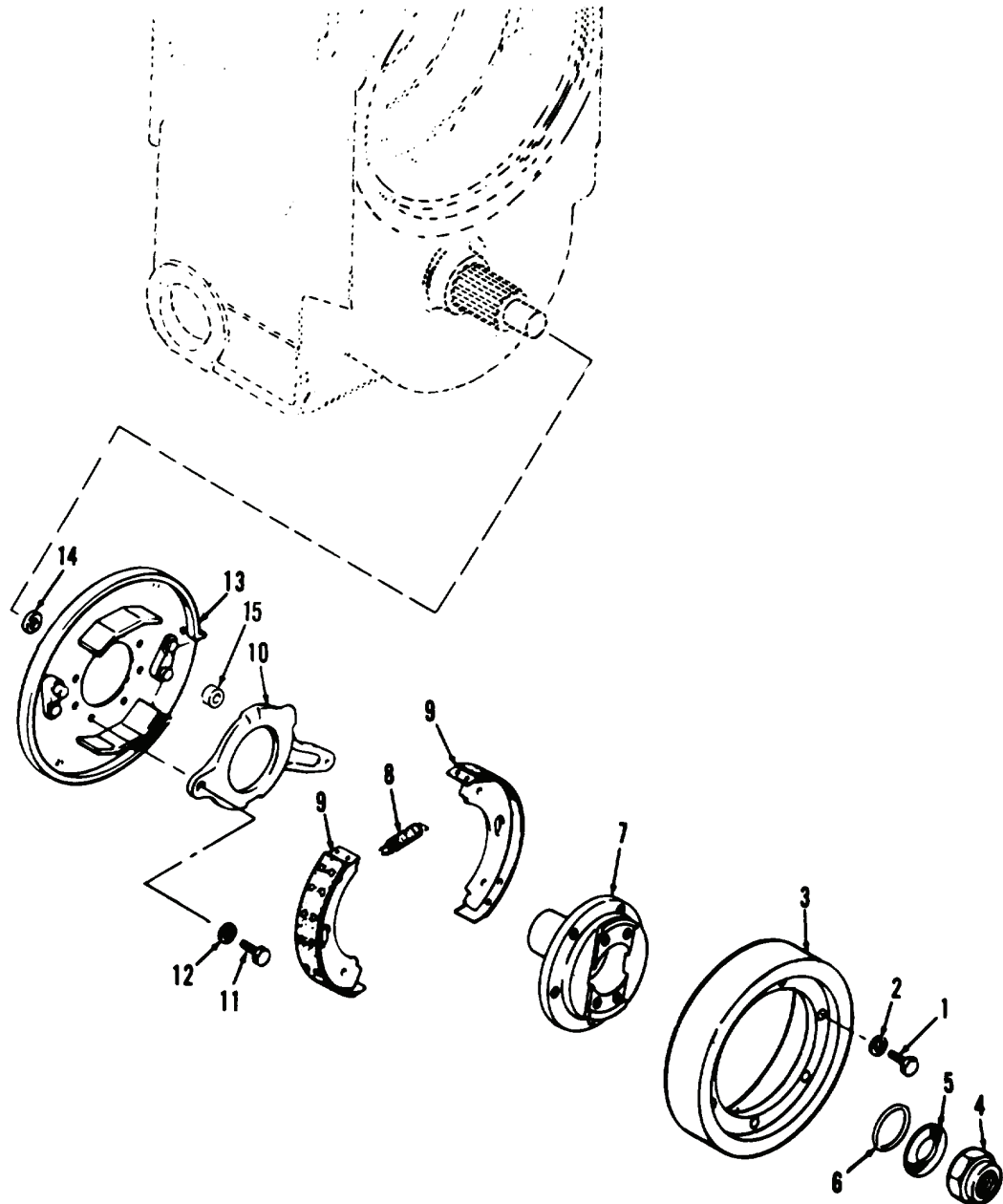

Figure 4. Parking Brake Assembly.

TA502381

**INSTALLATION/REPLACEMENT - CONTINUED**

9. Position brake drum (Figure 5, Item 3) on brake flange (Figure 5, Item 7) and install six new lockwashers (Figure 5, Item 2) and capscrews (Figure 5, Item 1). Tighten capscrews to 41 to 49 lb-ft (56 to 66 Nm).
10. Reconnect and adjust parking brake linkage (WP 0161).



TA502381

**Figure 5. Parking Brake Assembly.****END OF TASK****END OF WORK PACKAGE**

---

## ORGANIZATIONAL MAINTENANCE INSTRUCTIONS

### SERVICE BRAKE MAINTENANCE

Inspection, Removal, Cleaning, Post-Removal Inspection, Repair,  
Installation/Replacement, Adjustment, Bleeding Brakes

---

#### INITIAL SETUP

##### Maintenance Level

Organizational

##### Tools and Special Tools

Tool kit, general mechanic's (Item 15, WP 0309)  
Shop equipment, common no. 1 (Item 2, WP 0309)  
Container  
Shop vacuum cleaner  
Wood blocks (2), 6 x 6 x 18 in.

##### Materials/Parts

Brake fluid, automotive, silicone (Item 6, WP 0310)  
Cleaning compound, solvent (Item 10, WP 0310)  
Rag, wiping (Item 26, WP 0310)

##### Materials/Parts - Continued

Lockwasher (2)

##### Personnel Required

Two

##### References

WP 0164

##### Equipment Condition

Engine OFF  
Vehicle parked on level surface  
Wheels blocked  
Parking brake applied  
Wheel removed (WP 0169)  
Axle shaft and hub and drum assembly removed  
(WP 0160)

---

**WARNING**

Tire and wheel assembly must be removed before removing axle shaft and hub and drum assembly to avoid damaging axle oil seal. Damage to seal can result in contamination of brake linings and brake failure. Failure to follow this warning may cause injury or death to personnel.

**INSPECTION**

1. At front axle, right side, inspect shoe and lining assemblies (Figure 1, Item 6) for wear and signs of overheating and lubricant contamination. Replace if worn to 3/32 in. (2.4 mm) or less, or if contaminated by lubricant or brake fluid.

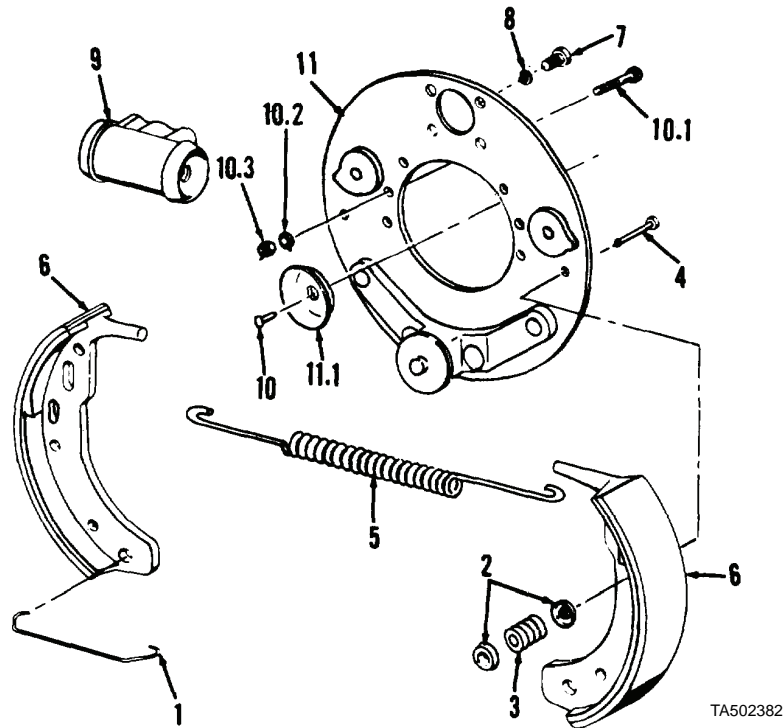

Figure 1. Service Brake Assembly.

**CAUTION**

Do not depress brake pedal completely in step 2; depress pedal only enough to ensure brake shoes expand. Fully depressing brake pedal could cause damage to equipment.

2. At wheel cylinder (Figure 1, Item 9), inspect for fluid leakage at boots (Figure 2). Depress brake pedal and ensure brake shoes expand. Release brake pedal and ensure brake shoes retract. Replace brake shoes if necessary.

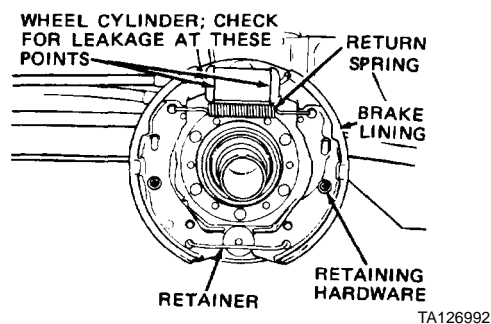

Figure 2. Service Brake.



---

**INSPECTION - CONTINUED****NOTE**

If brake shoes do not expand or retract in step 2, this indicates that wheel cylinder piston is sticking.

3. Inspect retaining hardware for missing parts. Replace missing parts.

**NOTE**

If brake shoes, wheel cylinder, and retaining hardware are okay, reinstall axle shaft and hub and drum assembly (WP 0160) and wheel assembly (WP 0169) and perform *Inspection* procedures on remaining wheel and axle in this work package procedures on remaining wheel and axle. If brake shoes, wheel cylinder, or retaining hardware are not okay or other problems are observed, proceed to *Removal* in this work package.

**END OF TASK****REMOVAL**

1. Remove retainer spring (Figure 1, Item 1) from shoe and lining assemblies (Figure 1, Item 6).
2. Hold head of two anti-rattle rods (Figure 1, Item 4) to prevent from turning.
3. Use pliers to depress and turn two outer retainers (Figure 1, Item 2) 1/4 turn, slowly release spring pressure, and remove.
4. Remove two springs (Figure 1, Item 3) and inside retainers (Figure 1, Item 2) from two rods (Figure 1, Item 4).
5. Remove two rods (Figure 1, Item 4) from shoe and lining assemblies (Figure 1, Item 6) and backing plate (Figure 1, Item 11).
6. Remove return spring (Figure 1, Item 5) from two shoe and lining assemblies (Figure 1, Item 6).
7. Remove two shoe and lining assemblies (Figure 1, Item 6) from backing plate (Figure 1, Item 11).
8. Remove brake tube and fitting from wheel cylinder (WP 0164).

**NOTE**

Remove capscrews, lockwashers, and wheel cylinder only if required for replacement.

9. Remove two capscrews (Figure 1, Item 7) and lockwashers (Figure 1, Item 8) from wheel cylinder (Figure 1, Item 9). Discard lockwashers.
10. Remove wheel cylinder (Figure 1, Item 9) from backing plate (Figure 1, Item 11).

**END OF TASK**

**CLEANING**

1. Wipe shoe and lining assemblies (Figure 3, Item 6) and wheel cylinder (Figure 3, Item 9) clean with a clean, dry cloth only.

**WARNING**

- Solvent cleaning compound MIL-PRF-680 Type III is an environmentally compliant and low toxic material. However, it may be irritating to the eyes and skin. Use protective gloves and goggles. Use in well-ventilated areas. Keep away from open flames and other sources of ignition. Failure to do so may result in injury or death to personnel.
  - Particles blown by compressed air are hazardous. DO NOT exceed 15 PSI (103 kPa) nozzle pressure when drying parts with compressed air. DO NOT direct compressed air against human skin. Make sure air stream is directed away from user and other personnel in the area. To prevent injury, user must wear protective goggles or face shield. Failure to follow this warning may result in injury to personnel.
2. Use solvent cleaning compound to clean all other parts. Dry thoroughly with compressed air.

**END OF TASK****POST - REMOVAL INSPECTION**

1. Inspect shoe and lining assemblies (Figure 3, Item 6). Replace if lining glazed, scored, cracked, deteriorated, worn to 3/32 in. (2.4 mm) or less, or if brake shoe or pawl holes worn.
2. Inspect springs (Figure 3, Items 1, 3, and 5). Replace if bent, cracked, distorted, or stretched.
3. Inspect retainer (Figure 3, Item 2) and rod (Figure 3, Item 4). Replace if cracked, bent, or corroded.
4. Inspect capscrews (Figure 3, Item 7). Replace if worn, or if threads damaged.

**NOTE**

Inspect under wheel cylinder rubber boots for damage.

5. Inspect wheel cylinder (Figure 3, Item 9). Replace if leaking, cracked, chipped, threads damaged, or rubber boots deteriorated.
6. Inspect backing plate (Figure 3, Item 11). Replace if worn, distorted, or damaged, or if rivets loose or sheared (see step 8).
7. Inspect oil slinger (Figure 3, Item 11.1). Replace if damaged or distorted (see step 8).
8. Remove six rivets (Figure 3, Item 10) or six capscrews (Figure 3, Item 10.1), washers (Figure 3, Item 10.2), and nuts (Figure 3, Item 10.3). Drill and press rivets (Figure 3, Item 10), if used, from plate (Figure 3, Item 11), oil slinger (Figure 3, Item 11.1), and axle housing. If capscrews (Figure 3, Item 10.1), washers (Figure 3, Item 10.2), and nuts (Figure 3, Item 10.3) are used, remove these parts. Support plate (Figure 3, Item 11) and oil slinger (Figure 3, Item 11.1).
9. Remove backing plate assembly (Figure 3, Item 11) and oil slinger (Figure 3, Item 11.1) from axle housing.
10. Position new backing plate assembly (Figure 3, Item 11) and oil slinger (Figure 3, Item 11.1). Clamp backing plate to axle housing with C-clamps so rivet holes are in alignment.

**NOTE**

Be sure wheel cylinder mounting holes in backing plate are at top of axle housing.

11. Install six capscrews (Figure 3, Item 10.1), washers (Figure 3, Item 10.2), and nuts (Figure 3, Item 10.3) on backing plate assembly (Figure 3, Item 11).

## POST - REMOVAL INSPECTION - CONTINUED

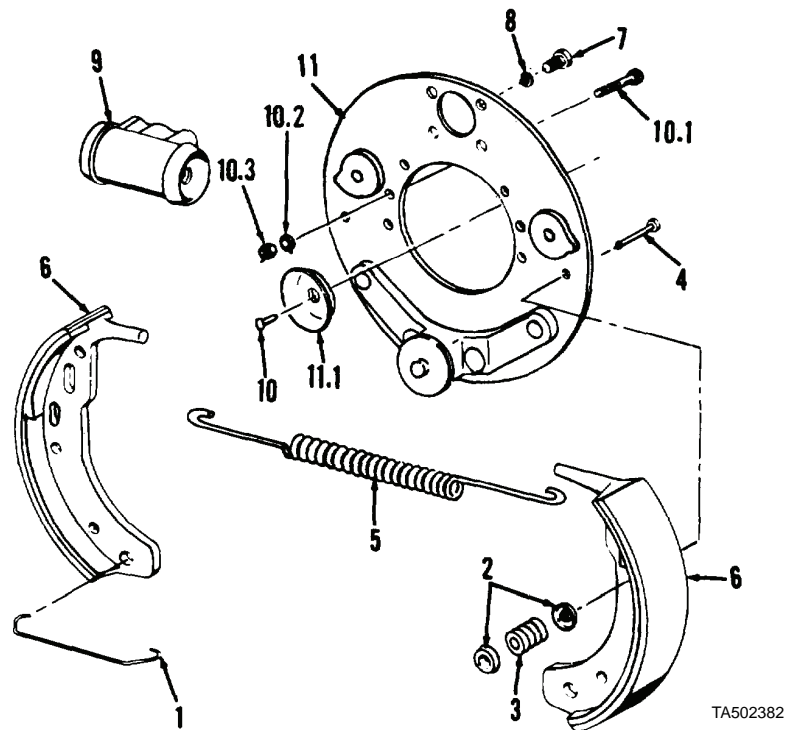

Figure 3. Service Brake Assembly.

## END OF TASK

## INSTALLATION/REPLACEMENT

1. Position wheel cylinder (Figure 3, Item 9) on backing plate (Figure 3, Item 11).
2. Install two new lockwashers (Figure 3, Item 8) and capscrews (Figure 3, Item 7) and tighten capscrews until wheel cylinder (Figure 3, Item 9) is securely mounted.
3. Install fitting and brake tube and tighten until securely mounted to wheel cylinder (Figure 3, Item 9).
4. Install two shoe and lining assemblies (Figure 3, Item 6).
5. Insert two anti-rattle rods (Figure 3, Item 4) through hole in backing plate (Figure 3, Item 11) and brake shoe.
6. Install two retainers (Figure 3, Item 2) and springs (Figure 3, Item 3). Guide one retainer and spring over rod (Figure 3, Item 4), then push head of rod and outside retainer to compress spring. Rotate outside retainer 1/4 turn and release.
7. Install retainer spring (Figure 3, Item 1) and return spring (Figure 3, Item 5) in two shoe and lining assemblies (Figure 3, Item 6).
8. Install hub and drum assembly and axle shaft (WP 0160).

## NOTE

Perform *Adjustment*, step 1, in this work package before lowering vehicle wheel to ground.

9. Install wheel (WP 0169).

## END OF TASK

**ADJUSTMENT**

1. Locate front axle backing plate, back (axle housing) side, right side of vehicle.

**NOTE**

If brake line was disconnected from wheel cylinder, bleed brakes (see *Bleeding Brakes* in this work package) before adjusting brake lining-to-drum clearance.

2. Actuate brake pedal to center brake shoe and lining assemblies in drum.
3. Turn two cam adjusting bolts to expand brake shoes until slight drag can be felt while drum is rotating (Figure 4).

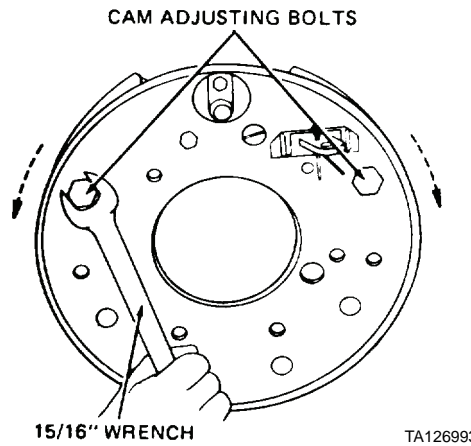

**Figure 4. Cam Adjusting Bolts (Expand).**

4. Turn two cam adjusting bolts to contract brake shoes until drum rotates freely (no drag) (Figure 5).

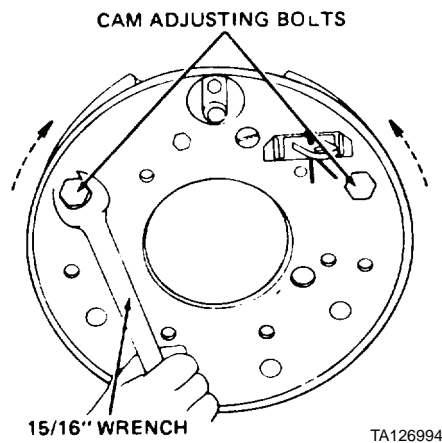

**Figure 5. Cam Adjusting Bolts (Contract).**

**NOTE**

After adjustment, repeat steps 1 through 4 for remaining brake assemblies.

**END OF TASK**

**BLEEDING BRAKES**

1. Remove brake valve fill plug (Figure 6).

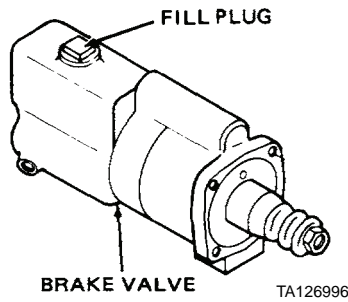
**Figure 6. Brake Valve and Fill Plug.**

2. Fill brake valve with brake fluid to within 1/2 in. (13 mm) of fill plug opening.
3. Install fill plug on brake valve.

**NOTE**

When bleeding brakes, slip hose over bleeder valve with opposite end of hose in clear container. Place small amount of brake fluid in container so that bubbles can be seen when bleeding brakes. Pressure bleeder may be used for bleeding brakes. Always bleed brakes with brake drum installed.

4. Close bleeder valve (Figure 7).

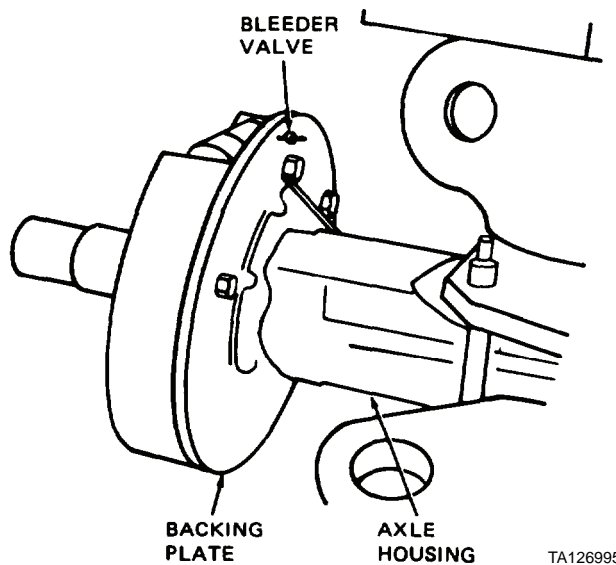
**Figure 7. Backing Plate.**

5. Have an assistant pump brake pedal and hold it down.
6. Momentarily open bleeder valve and turn counterclockwise until brake pedal nears bottom of travel, then turn clockwise to close.

**NOTE**

Repeat steps 5 and 6 until a steady stream of brake fluid flows from open bleeder valve when brake pedal is depressed.

7. Remove brake valve fill plug.
8. Refill brake valve with brake fluid to within 1/2 in. (13 mm) of fill plug opening.
9. Install fill plug.

**BLEEDING BRAKES - CONTINUED****NOTE**

Repeat steps 7 through 9 at remaining bleeder valves in the following order: left rear, right front, left front.

10. Tighten transmission control valve plug (Figure 8).
11. Have assistant hold down declutch pedal.
12. Momentarily open plug. Turn counterclockwise to open then clockwise to close when air is removed from line.

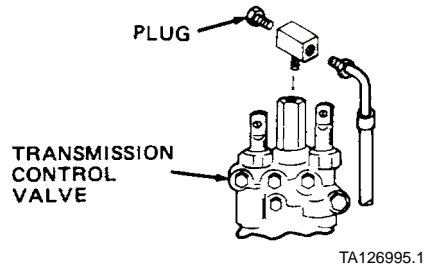

**Figure 8. Control Valve and Plug.**

**NOTE**

Repeat steps 11 and 12 until a steady stream of brake fluid flows from loosened plug.

13. Repeat steps 7 through 9 to fill brake valve with brake fluid.

**END OF TASK**

**END OF WORK PACKAGE**

---

# ORGANIZATIONAL MAINTENANCE INSTRUCTIONS

## BRAKE HOSES, LINES, AND FITTINGS REPLACEMENT

### Removal, Cleaning, Inspection, Installation

---

#### INITIAL SETUP

**Maintenance Level**

Organizational

**Tools and Special Tools**

Tool kit, general mechanic's (Item 15, WP 0309)

Shop equipment, common no. 1 (Item 2, WP 0309)

**Materials/Parts**

Brake fluid, automotive, silicone (Item 6, WP 0310)

Cleaning compound, solvent (Item 10, WP 0310)

Rag, wiping (Item 26, WP 0310)

**Materials/Parts - Continued**

Strap, tiedown (Item 32, WP 0310)

Gasket (4)

Lockwasher (2)

**References**

WP 0168

**Equipment Condition**

Vehicle parked on level surface

Engine OFF

Parking brake applied

Left side panel removed (WP 0179)

Chassis guard removed (WP 0188)

---

## LEAK INSPECTION

Perform leak inspection as indicated by Figure 1.

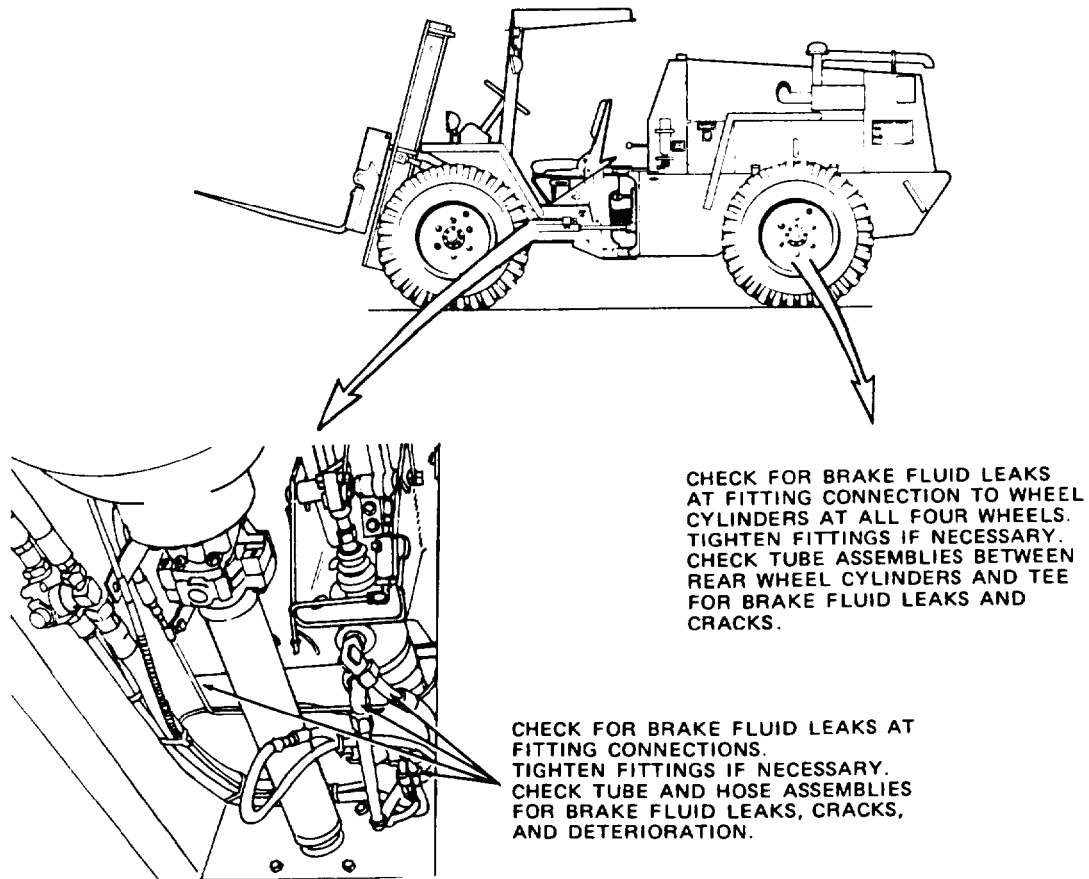

TA126997

**Figure 1. Brake Hoses, Lines, and Fittings.**

## END OF TASK

### REMOVAL

1. At front chassis, bottom left side, remove two connector bolts (Figure 2, Item 1) from hydraulic brake valve.
2. Remove two fittings (Figure 2, Item 3) and four gaskets (Figure 2, Items 2 and 4) from hydraulic brake valve. Discard gaskets.
3. At rear chassis, bottom center, cut and remove nine tiedown straps (Figure 2, Item 5) from hoses (Figure 2, Items 6 and 16). Discard tiedown straps.
4. Remove brake hose (Figure 2, Item 6) from hydraulic brake valve.
5. Remove hose (Figure 2, Item 7), tee (Figure 2, Item 8), and fitting (Figure 2, Item 9) from hydraulic brake valve.
6. Remove nut (Figure 2, Item 10), lockwasher (Figure 2, Item 11), and capscrew (Figure 2, Item 12) from clamp (Figure 2, Item 13). Discard lockwasher.
7. Remove clamp (Figure 2, Item 13) from tube (Figure 2, Item 14).
8. Remove tube (Figure 2, Item 14), two fittings (Figure 2, Item 15), and hose (Figure 2, Item 16) from declutch valve.
9. Disconnect hose (Figure 2, Item 16) from tee (Figure 2, Item 17).



**REMOVAL - CONTINUED**

10. Remove tee (Figure 2, Item 17) and plug (Figure 2, Item 18) from transmission control valve.
11. Disconnect brake tube (Figure 2, Item 19) from strap tee (Figure 2, Item 23).
12. Remove two tube clamps (Figure 2, Item 20), brake tubes (Figure 2, Items 21 and 22), and strap tee (Figure 2, Item 23) from vehicle.
13. Remove nut (Figure 2, Item 10), lockwasher (Figure 2, Item 11), and capscrew (Figure 2, Item 12) from clamp (Figure 2, Item 13). Discard lockwasher.
14. Remove clamps (Figure 2, Items 13 and 20) from hose (Figure 2, Item 6) and tube (Figure 2, Item 21).
15. Remove hose (Figure 2, Item 6), brake tubes (Figure 2, Items 21 and 22), and strap tee (Figure 2, Item 23) from vehicle.

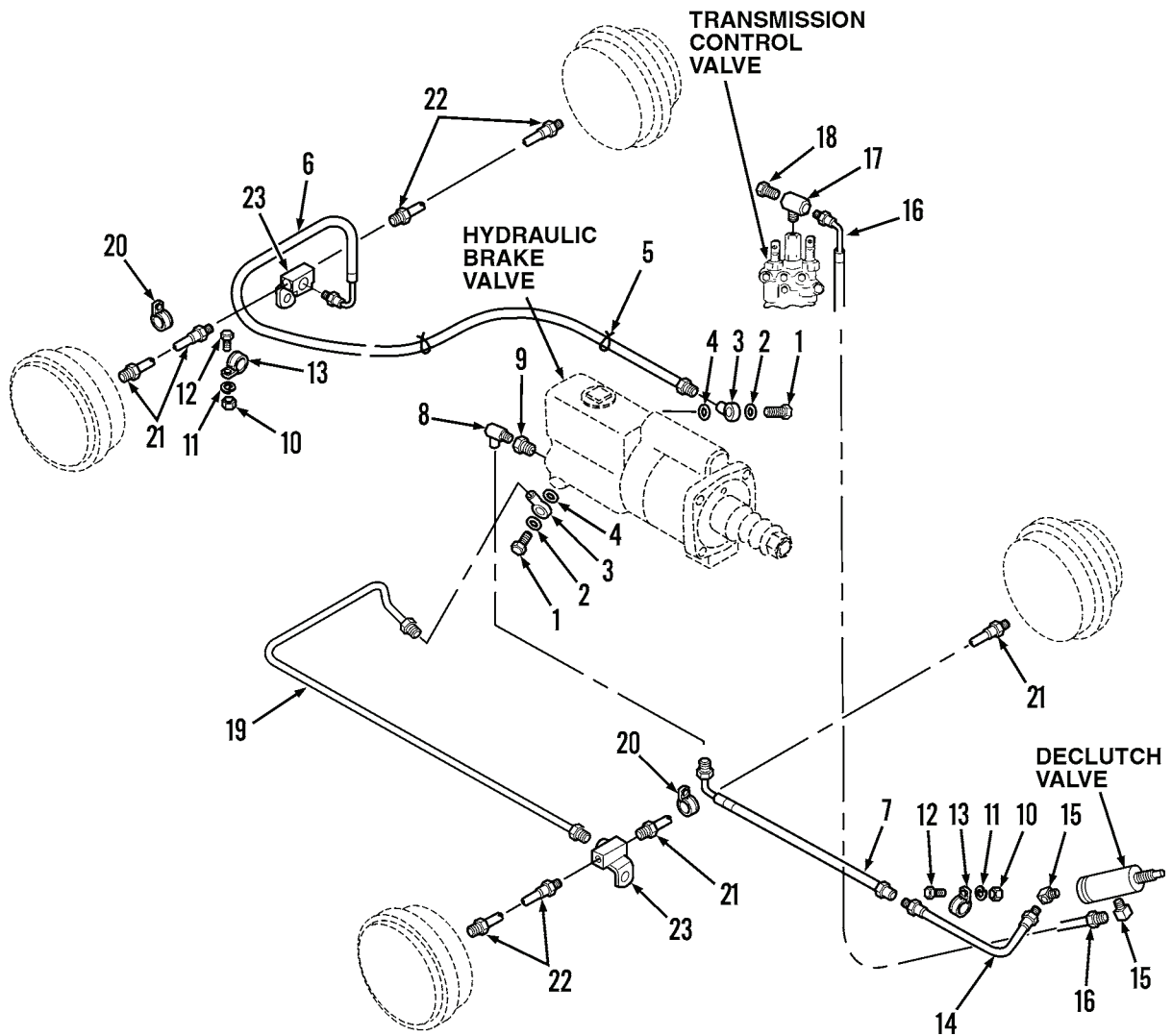

444-1131

**Figure 2. Brake Hose Assembly.****END OF TASK**

**CLEANING****WARNING**

- Solvent cleaning compound MIL-PRF-680 Type III is an environmentally compliant and low toxic material. However, it may be irritating to the eyes and skin. Use protective gloves and goggles. Use in well-ventilated areas. Keep away from open flames and other sources of ignition. Failure to do so may result in injury or death to personnel.
  - Particles blown by compressed air are hazardous. DO NOT exceed 15 PSI (103 kPa) nozzle pressure when drying parts with compressed air. DO NOT direct compressed air against human skin. Make sure air stream is directed away from user and other personnel in the area. To prevent injury, user must wear protective goggles or face shield. Failure to follow this warning may result in injury to personnel.
1. Use solvent cleaning compound to clean all parts. Dry thoroughly with compressed air.
  2. After cleaning hoses, fittings, and tubes, flush interior with clean brake fluid to remove all traces of cleaning solvent.

**END OF TASK****INSPECTION**

1. Inspect clamps (Figure 3, Items 13 and 20). Replace if damaged.
2. Inspect all fittings. Replace if cracked, or if threads damaged.
3. Inspect hoses (Figure 3, Items 6, 7, and 16). Replace if cracked, split, or deteriorated, or if fitting threads damaged.

**END OF TASK****INSTALLATION**

1. Install strap tee (Figure 3, Item 23) on rear axle.
2. Connect hose (Figure 3, Item 6) and brake tubes (Figure 3, Items 21 and 22) to rear axle and tighten.
3. Position two clamps (Figure 3, Items 13 and 20) on hose (Figure 3, Item 6) and brake tube (Figure 3, Item 21).
4. Install capscrew (Figure 3, Item 12), new lockwasher (Figure 3, Item 11), and nut (Figure 3, Item 10) and tighten nut until clamp (Figure 3, Item 13) is securely mounted.
5. Install tee (Figure 3, Item 17) and plug (Figure 3, Item 18) and tighten until securely mounted to transmission.
6. Connect hose (Figure 3, Item 16) to tee (Figure 3, Item 17) and tighten.
7. Install nine new tiedown straps (Figure 3, Item 5) around hoses (Figure 3, Items 6 and 16).
8. Install strap tee (Figure 3, Item 23) on front axle.
9. Install brake tubes (Figure 3, Items 21 and 22) on front axle and tighten.
10. Install clamp (Figure 3, Item 20) on tube (Figure 3, Item 21).
11. Connect supply tube (Figure 3, Item 19) to tee (Figure 3, Item 23) and tighten.
12. Connect two fittings (Figure 3, Item 15), hose (Figure 3, Item 16), and tube (Figure 3, Item 14) to declutch valve and tighten.
13. Position clamp (Figure 3, Item 13) on tube (Figure 3, Item 14).
14. Install capscrew (Figure 3, Item 12), new lockwasher (Figure 3, Item 11), and nut (Figure 3, Item 10) and tighten nut until clamp (Figure 3, Item 13) is securely mounted.

**INSTALLATION - CONTINUED**

15. Connect fitting (Figure 3, Item 9), tee (Figure 3, Item 8), and hose (Figure 3, Item 7) to hydraulic brake valve and tighten.
16. Connect two fittings (Figure 3, Item 3) to hose (Figure 3, Item 6) and tube (Figure 3, Item 19) and tighten.
17. Connect two fittings (Figure 3, Item 3), four new gaskets (Figure 3, Items 2 and 4), and connector bolts (Figure 3, Item 1) to hydraulic brake valve and tighten.
18. Connect inlet hose (Figure 3, Item 7) to tube (Figure 3, Item 14) and tighten.
19. Bleed brake lines (WP 0163).
20. Depress brake pedal with engine running. Check for proper brake operation.

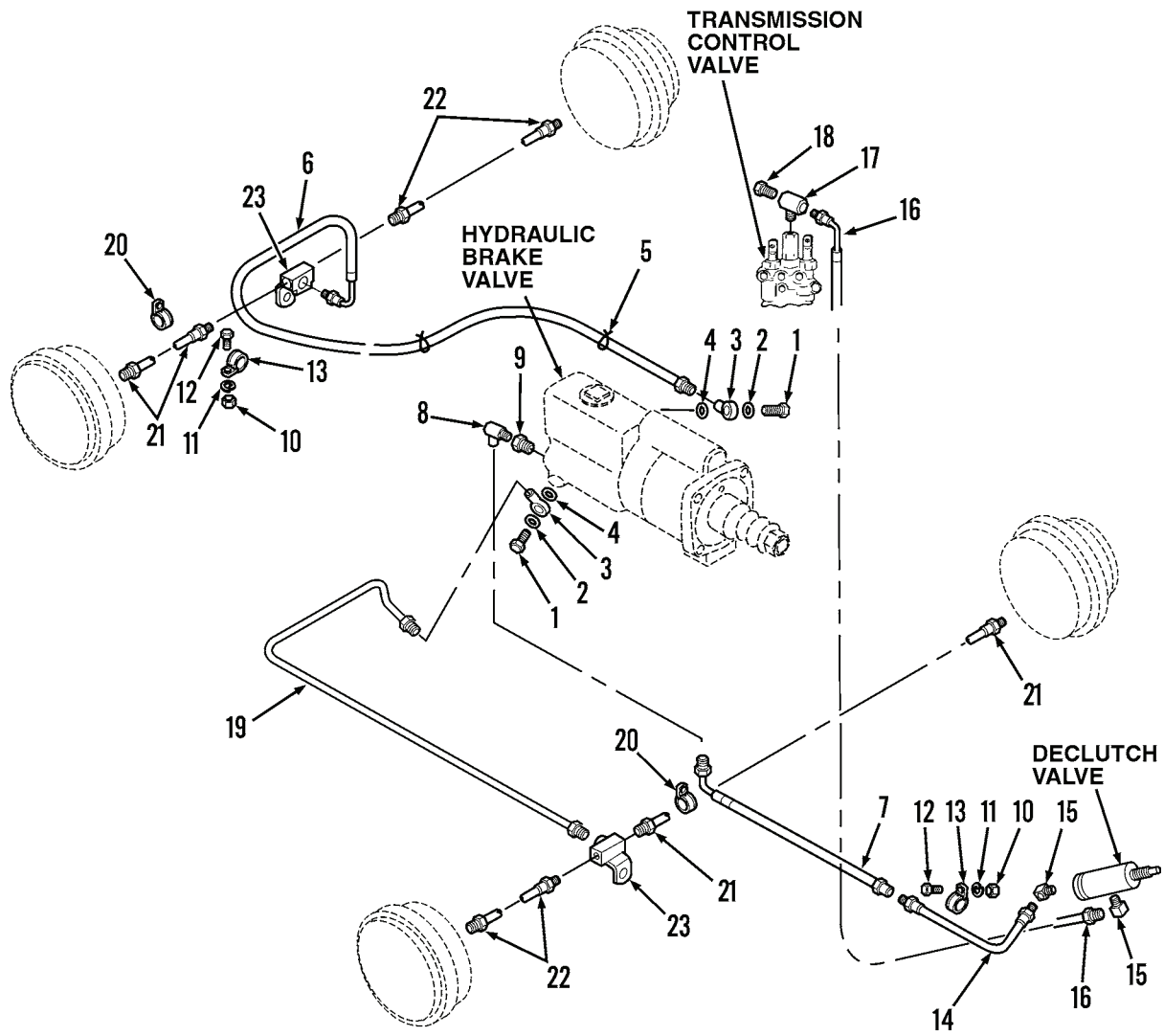

444-1131

**Figure 3. Brake Hose Assembly.**

**END OF TASK**

**END OF WORK PACKAGE**



---

## ORGANIZATIONAL MAINTENANCE INSTRUCTIONS

### BRAKE MASTER CYLINDER REPLACEMENT

Leak Inspection, Cleaning, Inspection, Removal, Installation/Replacement

---

#### INITIAL SETUP

##### Maintenance Level

Organizational

##### Tools and Special Tools

Tool kit, general mechanic's (Item 15, WP 0309)  
Shop equipment, common no. 1 (Item 2, WP 0309)  
Wood blocks (2), 6 x 6 x 18 in.

##### Materials/Parts

Brake fluid, automotive, silicone (Item 6, WP 0310)  
Cleaning compound, solvent (Item 10, WP 0310)  
Grease, automotive and artillery (Item 17, WP 0310)  
Rag, wiping (Item 26, WP 0310)

##### Materials/Parts - Continued

Lockwasher (3)  
O-ring

##### References

WP 0163

##### Equipment Condition

Engine OFF  
Vehicle parked on level surface  
Wheels blocked  
Parking brake applied  
Stop light switch removed (WP 0126)  
Brake hoses, lines, and fittings disconnected from hydraulic brake valve (WP 0164)  
Chassis guard removed (WP 0188)

---

**LEAK INSPECTION**

Perform leak inspection as indicated by Figure 1.

**LEAK INSPECTION**

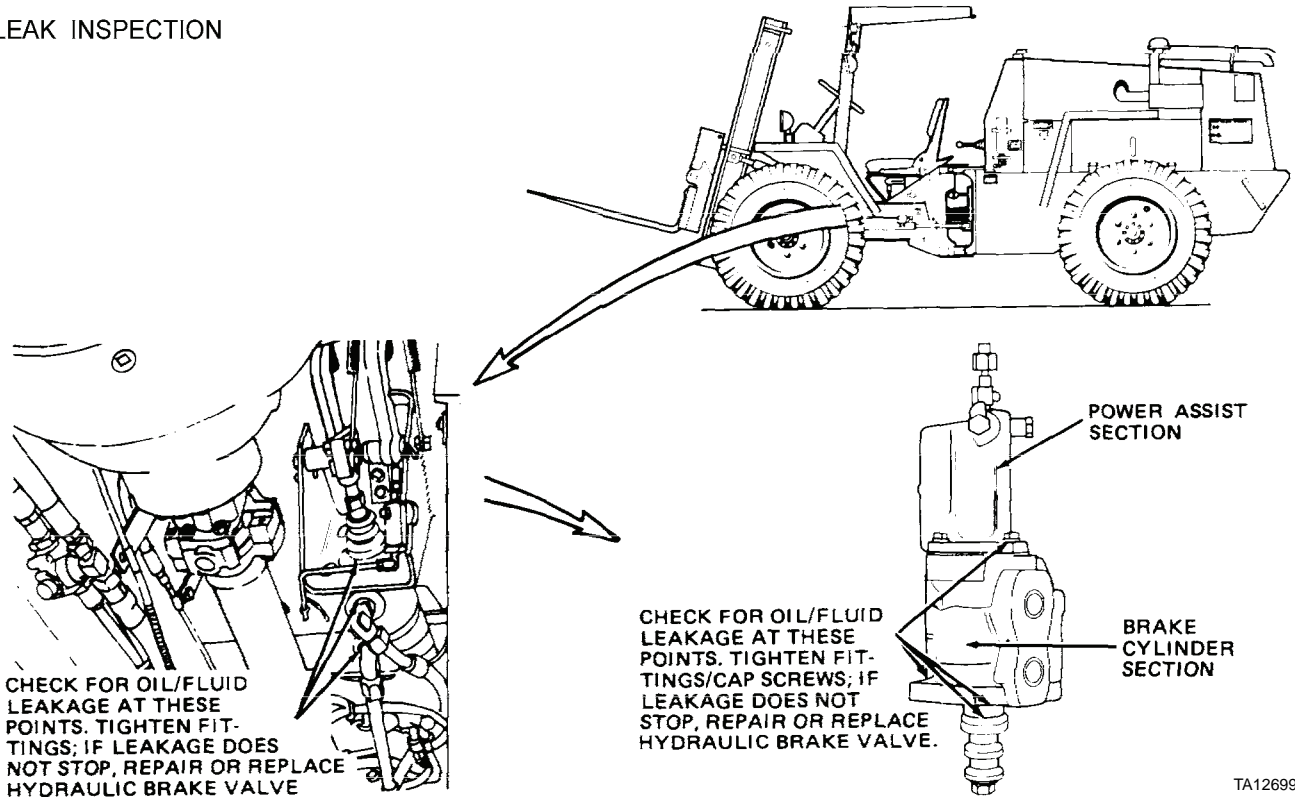

TA126999

**Figure 1. Brake Master Cylinder.**

**END OF TASK**

**CLEANING**



Solvent cleaning compound MIL-PRF-680 Type III is an environmentally compliant and low toxic material. However, it may be irritating to the eyes and skin. Use protective gloves and goggles. Use in well-ventilated areas. Keep away from open flames and other sources of ignition. Failure to do so may result in injury or death to personnel.

Use solvent cleaning compound to clean master cylinder and dry with clean rag. Clean outside of cylinder only.

**END OF TASK**

**INSPECTION**

1. Inspect capscrew (Figure 2, Item 1), lockwasher (Figure 2, Item 2), fill plug (Figure 2, Item 4), and O-ring (Figure 2, Item 5). Replace if worn, or if threads damaged. Discard O-ring.
2. Inspect body (Figure 2, Item 3). Replace master cylinder assembly if cracked or threads damaged.

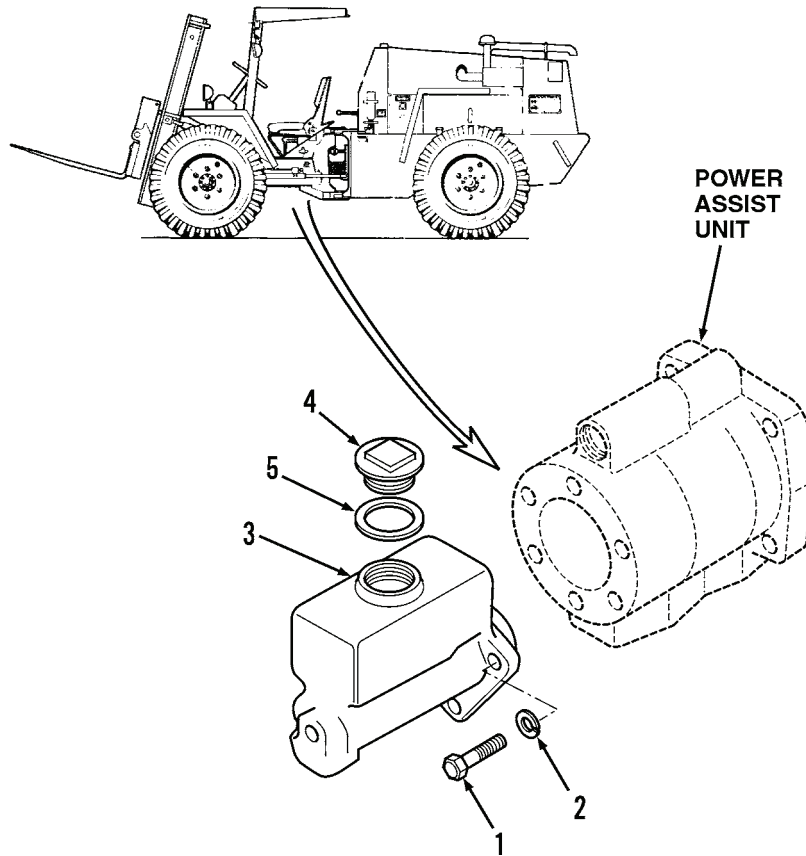

**Figure 2. Brake Master Cylinder Assembly.**

**END OF TASK****REMOVAL**

1. Remove three capscrews (Figure 2, Item 1) and lockwashers (Figure 2, Item 2) from master cylinder body (Figure 2, Item 3). Discard lockwashers.
2. Remove brake master cylinder body (Figure 2, Item 3) from power assist unit.

**END OF TASK**

**INSTALLATION/REPLACEMENT**

1. Lubricate mating surface on body (Figure 3). Lightly coat exterior area shown with grease.

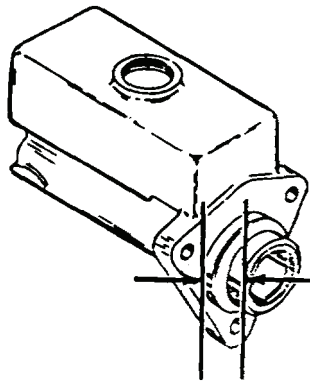

TA127004

**Figure 3. Brake Master Cylinder Mating Surface.**

2. Position brake master cylinder (Figure 4, Item 3) against power assist unit, with fill plug opening facing upward.
3. Install three new lockwashers (Figure 4, Item 2) and capscrews (Figure 4, Item 1) and tighten capscrews until brake master cylinder (Figure 4, Item 3) is securely mounted.
4. Connect brake hoses, lines, and fittings to hydraulic brake valve and tighten (WP 0164).
5. Install stop light switch on hydraulic brake valve (WP 0126).
6. Fill brake master cylinder (Figure 4, Item 3). Add clean brake fluid to within 1/2 in. (13 mm) of fill opening.



## INSTALLATION/REPLACEMENT - CONTINUED

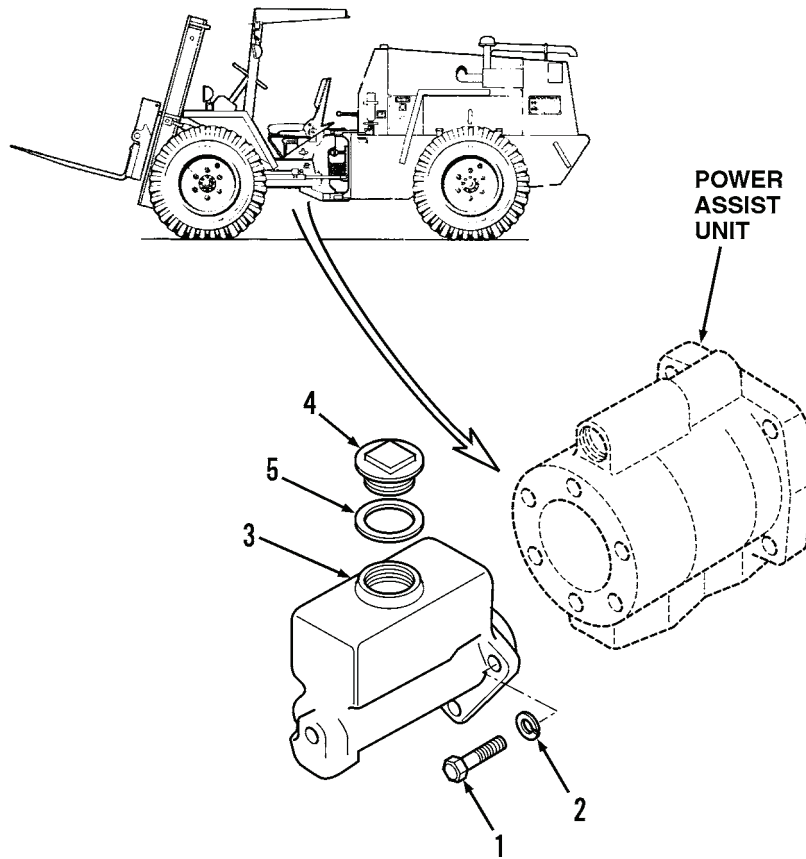

444-1133

**Figure 4. Brake Master Cylinder Assembly.**

7. Bleed brake lines (WP 0163).
8. Depress brake pedal with engine running. Check for proper brake operation.

**END OF TASK****END OF WORK PACKAGE**



---

# ORGANIZATIONAL MAINTENANCE INSTRUCTIONS

## BRAKE POWER ASSIST UNIT MAINTENANCE

Removal, Disassembly, Cleaning, Inspection, Assembly/Repair, Installation/Replacement

---

### INITIAL SETUP

#### Maintenance Level

Organizational

#### Tools and Special Tools

Tool kit, general mechanic's (Item 15, WP 0309)  
Shop equipment, common no. 1 (Item 2, WP 0309)  
Wood blocks (2), 6 x 6 x 18 in.

#### Materials/Parts

Cleaning compound, solvent (Item 10, WP 0310)  
Lubricating oil, OE/HDO-10 (Item 20, WP 0310)  
Rag, wiping (Item 26, WP 0310)  
Backup ring (3)  
Lockwasher (4)  
O-ring (5)  
Piston ring

#### Materials/Parts - Continued

Retaining ring  
Rubber cover  
U-cap seal (3)

#### References

WP 0021

#### Equipment Condition

Engine OFF  
Vehicle parked on level surface  
Wheels blocked  
Parking brake applied  
Brake master cylinder removed (WP 0165)  
Hydraulic lines and fittings disconnected from  
power assist unit (WP 0172)  
Brake pedal and declutch pedal removed (WP  
0168)

---

**REMOVAL**

1. Remove rubber cover (Figure 1, Item 1) from gland (Figure 1, Item 2).
2. Remove four capscrews (Figure 1, Item 3) and lockwashers (Figure 1, Item 4) from power assist unit body (Figure 1, Item 5). Discard lockwashers.
3. Remove power assist unit body (Figure 1, Item 5) by pulling straight from bracket until clear of push rod (Figure 1, Item 7), then lower and remove from vehicle.
4. Remove and discard rubber cover (Figure 1, Item 1) from push rod (Figure 1, Item 7).

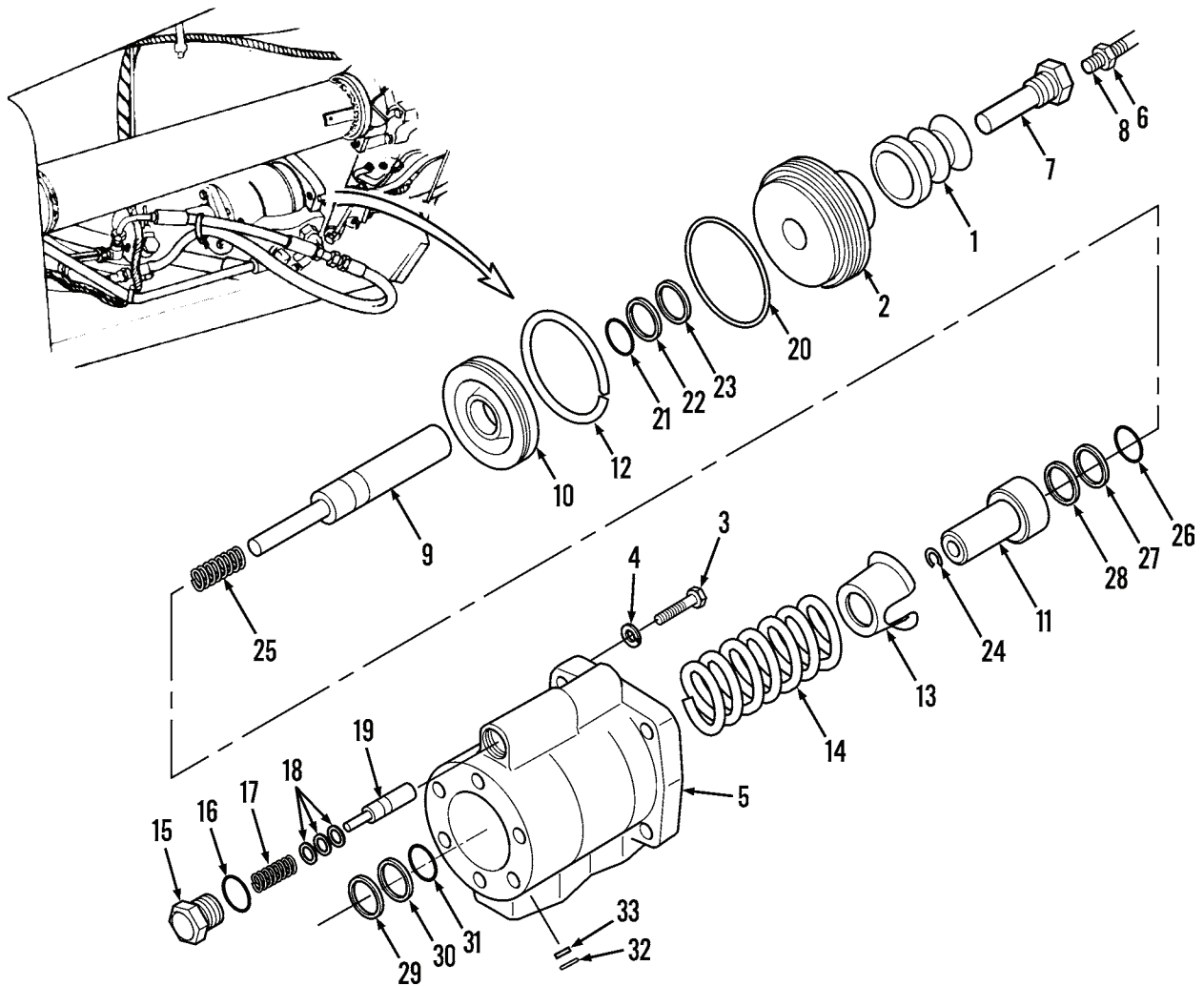

444-1135

**Figure 1. Brake Power Assist Unit Assembly.**

**END OF TASK**

**DISASSEMBLY**

1. Place power assist unit body (Figure 1, Item 5) in vise, with gland (Figure 1, Item 2) facing upward.

**WARNING**

Take care when removing gland. There will be spring tension against the gland. Failure to follow this warning may cause gland to fly into your eyes.

2. Remove gland (Figure 1, Item 2) from power assist unit body (Figure 1, Item 5).
3. Remove spool (Figure 1, Item 9), piston (Figure 1, Item 10), and spool cap (Figure 1, Item 11) from power assist unit body (Figure 1, Item 5).
4. Remove piston (Figure 1, Item 10) from spool (Figure 1, Item 9).
5. Remove and discard piston ring (Figure 1, Item 12) from piston (Figure 1, Item 10).
6. Remove spring retainer (Figure 1, Item 13) and spring (Figure 1, Item 14) from power assist unit body (Figure 1, Item 5).
7. Place power assist unit body (Figure 1, Item 5) in vise, with gland (Figure 1, Item 2) end facing down.
8. Remove end plug (Figure 1, Item 15) from power assist unit body (Figure 1, Item 5).
9. Remove and discard O-ring (Figure 1, Item 16) from end plug (Figure 1, Item 15).

**NOTE**

Spring and shim(s) are a matched set. Retain shim(s) for reassembly with original spring.

10. Remove spring (Figure 1, Item 17), shim(s) (Figure 1, Item 18), and poppet (Figure 1, Item 19) from power assist unit body (Figure 1, Item 5).
11. Remove and discard O-ring (Figure 1, Item 20) from gland (Figure 1, Item 2).
12. Remove and discard O-ring (Figure 1, Item 21), U-cup seal (Figure 1, Item 22), and backup ring (Figure 1, Item 23) from bore in gland (Figure 1, Item 2).
13. Place spool (Figure 1, Item 9) and spool cap (Figure 1, Item 11) in soft-jawed vise, with retaining ring (Figure 1, Item 24) facing upward.

**WARNING**

Take care when removing retaining ring. There will be spring tension against the spool cap. Failure to follow this warning may cause injury to your eyes by spool cap.

14. Remove and discard retaining ring (Figure 1, Item 24).
15. Remove spool cap (Figure 1, Item 11) and spring (Figure 1, Item 25) from spool (Figure 1, Item 9).
16. Remove and discard O-ring (Figure 1, Item 26), U-cup seal (Figure 1, Item 27), and backup ring (Figure 1, Item 28) from bore in spool cap (Figure 1, Item 11).
17. Remove and discard backup ring (Figure 1, Item 29), U-cup seal (Figure 1, Item 30), and O-ring (Figure 1, Item 31) from bore in power assist unit body (Figure 1, Item 5).
18. Remove retaining ring (Figure 1, Item 32) and filter (Figure 1, Item 33) from breather hole in power assist unit body (Figure 1, Item 5).

**END OF TASK**

**CLEANING****WARNING**

- Solvent cleaning compound MIL-PRF-680 Type III is an environmentally compliant and low toxic material. However, it may be irritating to the eyes and skin. Use protective gloves and goggles. Use in well-ventilated areas. Keep away from open flames and other sources of ignition. Failure to do so may result in injury or death to personnel.
  - Particles blown by compressed air are hazardous. DO NOT exceed 15 PSI (103 kPa) nozzle pressure when drying parts with compressed air. DO NOT direct compressed air against human skin. Make sure air stream is directed away from user and other personnel in the area. To prevent injury, user must wear protective goggles or face shield. Failure to follow this warning may result in injury to personnel.
1. Use solvent cleaning compound to clean all parts. Dry parts, except breather filter (Figure 2, Item 33), with compressed air.
  2. After cleaning internal metal parts, remove all traces of cleaning solvent by flushing with clean lubricating oil.

**END OF TASK****INSPECTION**

1. Inspect springs (Figure 2, Items 14 and 25). Replace if cracked, distorted, or broken.
2. Inspect spring (Figure 2, Item 17) and shim(s) (Figure 2, Item 18). Replace power assist unit if cracked or damaged.
3. Inspect capscrews (Figure 2, Item 3), power assist unit body (Figure 2, Item 5), end plug (Figure 2, Item 15), and gland (Figure 2, Item 2). Replace if cracked, worn, or threads damaged, or body bore scored, pitted, or burred.
4. Inspect push rod (Figure 2, Item 7), spool (Figure 2, Item 9), piston (Figure 2, Item 10), spool cap (Figure 2, Item 11), and poppet (Figure 2, Item 19). Replace if cracked, scored, pitted, or burred.

**END OF TASK****ASSEMBLY/REPAIR**

1. Install breather filter (Figure 2, Item 33) in breather hole of power assist unit body (Figure 2, Item 5).
2. Install retaining ring (Figure 2, Item 32). Push into breather hole until retaining ring is against shoulder of breather hole.
3. Lubricate power assist unit body (Figure 2, Item 5) with light coat of lubricating oil.
4. Install new O-ring (Figure 2, Item 31) in new U-cup seal (Figure 2, Item 30).
5. Install new U-cup seal (Figure 2, Item 30) and new O-ring (Figure 2, Item 31) in groove of bore at rear of power assist unit body (Figure 2, Item 5) with lips of U-cup seal facing body.
6. Install new backup ring (Figure 2, Item 29) against flat side of new U-cup seal (Figure 2, Item 30) in power assist unit body (Figure 2, Item 5) bore.
7. Install new O-ring (Figure 2, Item 26) in new U-cup seal (Figure 2, Item 27).
8. Lubricate spool cap (Figure 2, Item 11) with light coat of lubricating oil.
9. Install new backup ring (Figure 2, Item 28) against flat side of new U-cup seal (Figure 2, Item 27) in spool cap (Figure 2, Item 11) bore.
10. Install new U-cup seal (Figure 2, Item 27) and new O-ring (Figure 2, Item 26) in groove of spool cap (Figure 2, Item 11) bore, with lips of U-cup seal facing open end of spool cap bore.

**ASSEMBLY/REPAIR - CONTINUED**

11. Place spool (Figure 2, Item 9) in soft-jawed vise, with narrow end of spool facing up.
12. Install spring (Figure 2, Item 25) over narrow end of spool (Figure 2, Item 9).

**CAUTION**

Take care when installing spool cap not to damage U-cup seal.

13. Install spool cap (Figure 2, Item 11) over spool (Figure 2, Item 9) and against pressure of spring (Figure 2, Item 25).
14. Install new retaining ring (Figure 2, Item 24) into groove at end of spool cap (Figure 2, Item 11), and close with pliers until retaining ring is tight in groove.

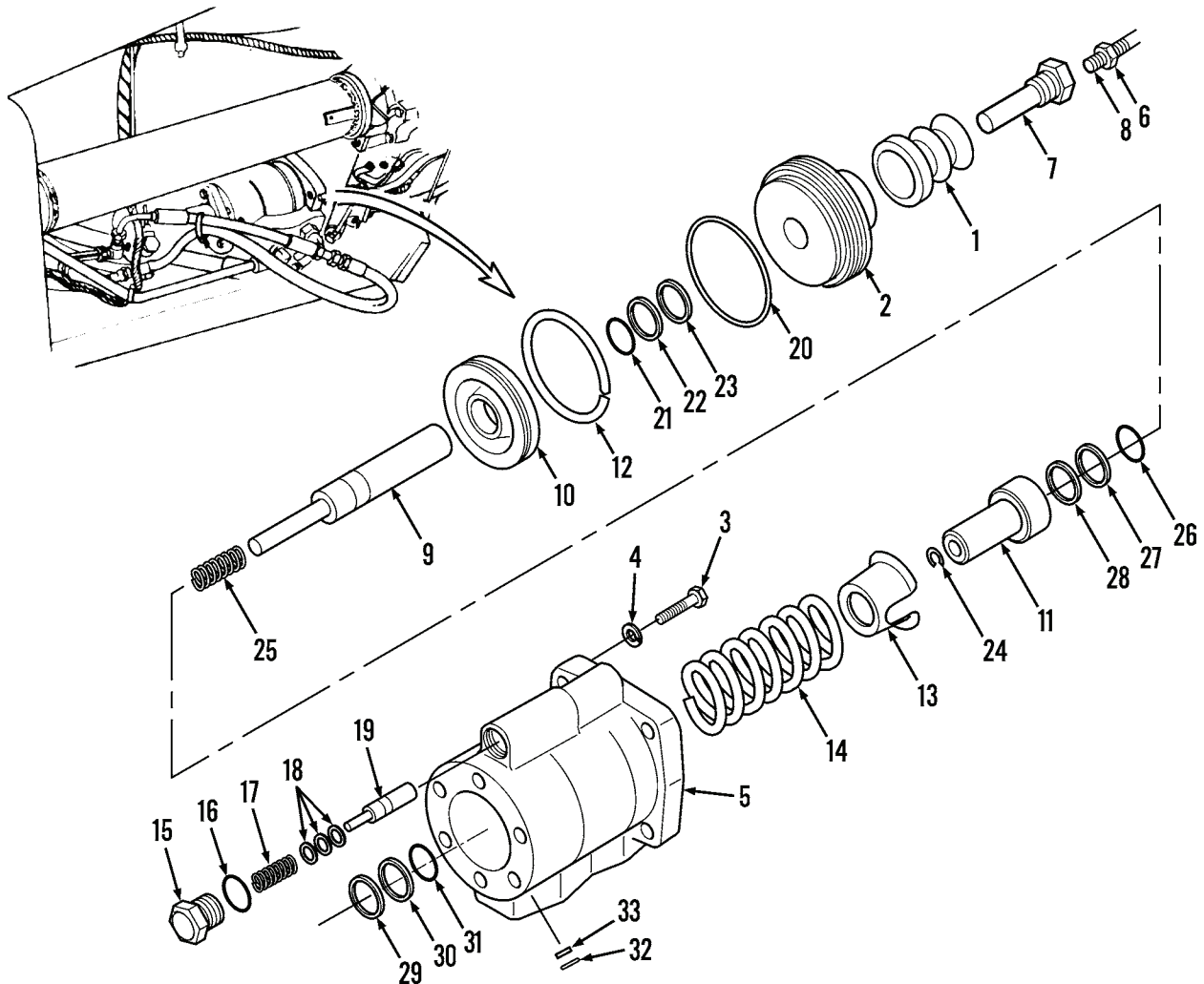

444-1135

**Figure 2. Brake Power Assist Unit Assembly.**

**ASSEMBLY/REPAIR - CONTINUED**

15. Install new O-ring (Figure 3, Item 21) in new U-cup seal (Figure 3, Item 22).
16. Lubricate gland (Figure 3, Item 2) with light coat of lubricating oil.
17. Install new backup ring (Figure 3, Item 23) against flat side of U-cup seal (Figure 3, Item 22) in gland (Figure 3, Item 2) bore.
18. Install new U-cup seal (Figure 3, Item 22) and new O-ring (Figure 3, Item 21) in groove of gland (Figure 3, Item 2) bore, with lips of new seal (Figure 3, Item 22) toward inner face of gland.
19. Install new O-ring (Figure 3, Item 20) in groove at outside diameter of gland (Figure 3, Item 2).
20. Place power assist unit body (Figure 3, Item 5) in vise with gland (Figure 3, Item 2) end facing down.
21. Lubricate poppet (Figure 3, Item 19) with light coat of lubricating oil.

**CAUTION**

Take care not to scratch or damage poppet during installation.

22. Install poppet (Figure 3, Item 19) in relief valve bore of power assist unit body (Figure 3, Item 5), with narrow end of poppet facing up. Be sure poppet goes fully down to seat.

**NOTE**

Spring and shim(s) are matched for proper relief pressure. Assemble power assist unit using original spring and shim(s) only.

23. Install shim(s) (Figure 3, Item 18), if used, by sliding over narrow end of poppet (Figure 3, Item 19) onto shoulder.
24. Install spring (Figure 3, Item 17) on poppet (Figure 3, Item 19).
25. Install new O-ring (Figure 3, Item 16) over threaded end of end plug (Figure 3, Item 15).
26. Install end plug (Figure 3, Item 15) and tighten.
27. Position power assist unit body (Figure 3, Item 5) in vise with gland (Figure 3, Item 2) end facing up.
28. Install spring (Figure 3, Item 14) and retainer (Figure 3, Item 13) in power assist unit body (Figure 3, Item 5) bore.
29. Install new piston ring (Figure 3, Item 12) on piston (Figure 3, Item 10).
30. Lubricate spool (Figure 3, Item 9) with light coat of lubricating oil.
31. Install piston (Figure 3, Item 10) as shown (Figure 3).
32. Lubricate piston (Figure 3, Item 10) and piston ring (Figure 3, Item 12) with light coat of lubricating oil.
33. Install spool cap (Figure 3, Item 11), spool (Figure 3, Item 9), and piston (Figure 3, Item 10). Position spool cap (Figure 3, Item 11) into bore of power assist unit body (Figure 3, Item 5); then lower spool, spool cap, and piston assembly onto spring (Figure 3, Item 14).
34. Lubricate new O-ring (Figure 3, Item 20) and new U-cup seals (Figure 3, Items 22 and 30) with light coat of lubricating oil.

**CAUTION**

Take care not to damage U-cup seals when installing gland.

35. Install gland (Figure 4, Item 2). Carefully push onto spool (Figure 4, Item 9) then push gland down against pressure of spring (Figure 4, Item 14) and screw several turns into power assist unit body (Figure 4, Item 5).
36. Push down spool (Figure 4, Item 9) to verify spool cap (Figure 4, Item 11) moves smoothly through bore.
37. Use spanner wrench or chain wrench to tighten gland (Figure 4, Item 2).
38. Install new rubber cover (Figure 4, Item 1). Push large end of cover onto groove around outside of gland (Figure 4, Item 2).
39. Remove power assist unit body (Figure 4, Item 5) from vise.



ASSEMBLY/REPAIR - CONTINUED

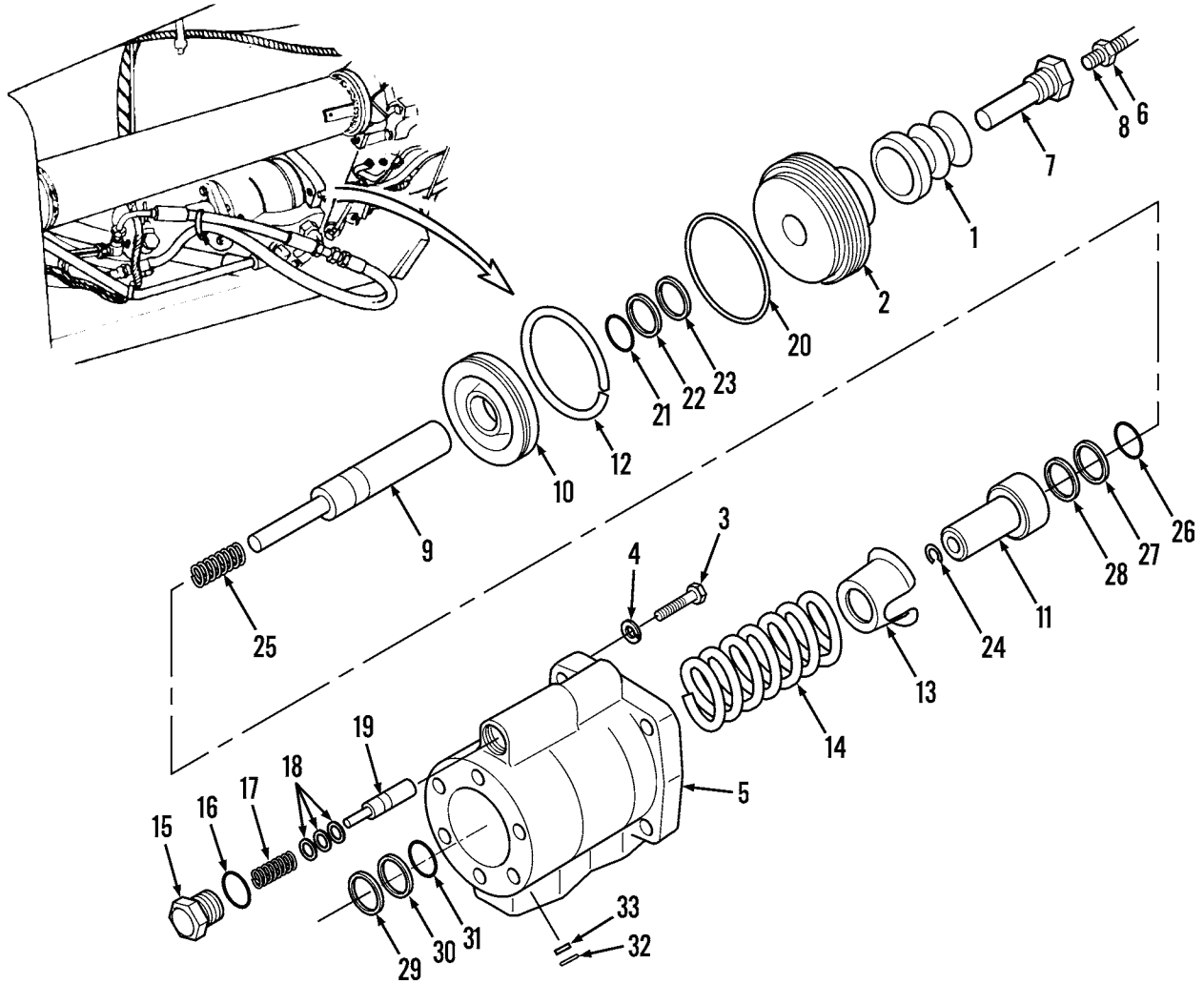

444-1135

Figure 3. Brake Power Assist Unit Assembly.

END OF TASK

---

**INSTALLATION/REPLACEMENT**

1. Install push rod (Figure 4, Item 7). Screw clockwise onto yoke (Figure 4, Item 8).
2. Slide new rubber cover (Figure 4, Item 1) over push rod (Figure 4, Item 7). Position bracket, with hydraulic ports in body facing down.
3. Install four new lockwashers (Figure 4, Item 4) and capscrews (Figure 4, Item 3) through bracket and tighten capscrews until power assist unit is securely mounted.
4. Connect hydraulic lines and fittings to ports on power assist unit body (Figure 4, Item 5) and tighten (WP 0172).
5. Install brake master cylinder (WP 0165).
6. Adjust free travel of brake pedal (WP 0168).
7. Test relief pressure of power assist unit (WP 0021, MALFUNCTION 8, step 7).
8. Depress brake pedal with engine running and check for proper brake operation.

INSTALLATION/REPLACEMENT - CONTINUED

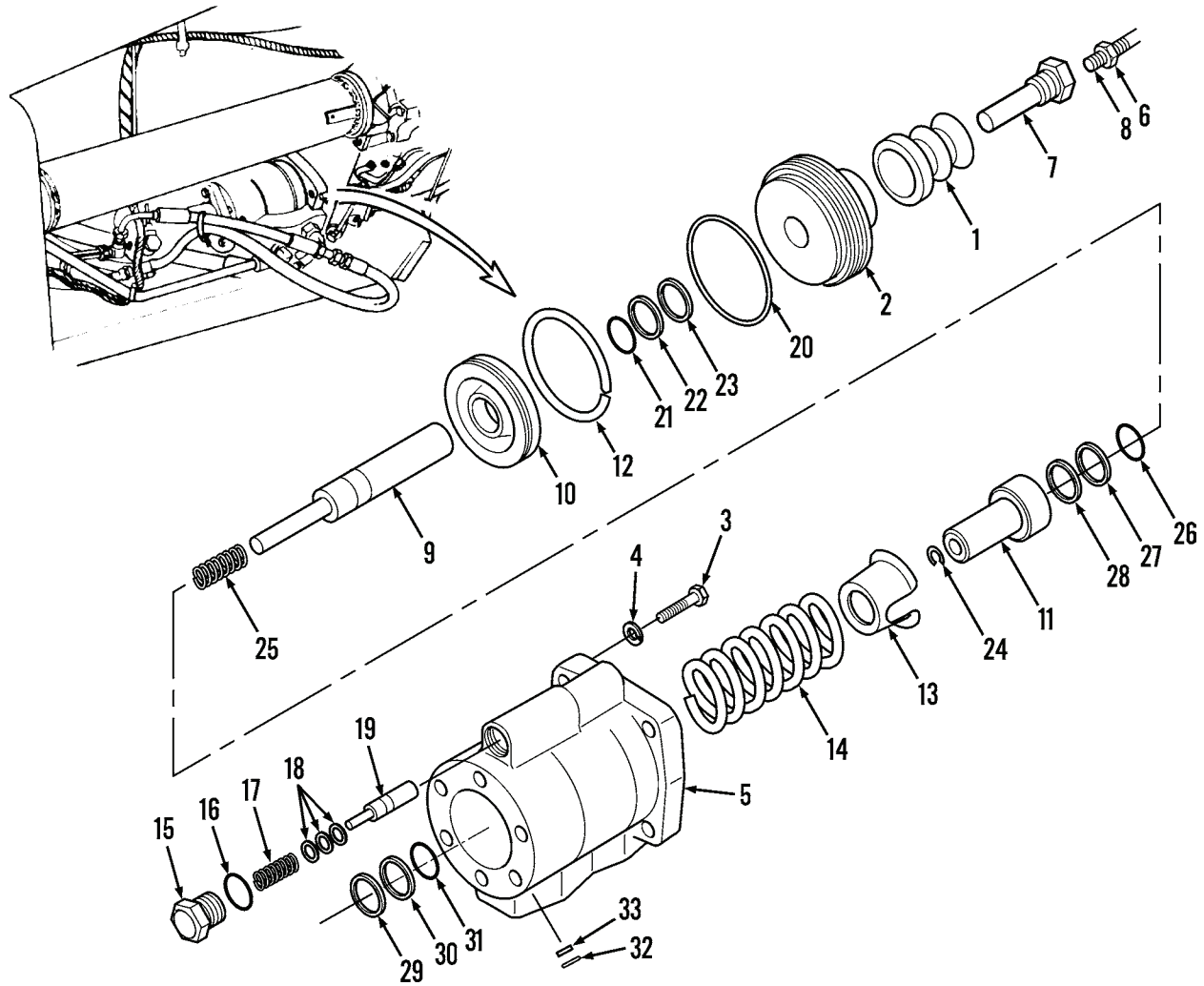

444-1135

Figure 4. Brake Power Assist Unit Assembly.

END OF TASK

END OF WORK PACKAGE



---

# ORGANIZATIONAL MAINTENANCE INSTRUCTIONS

## DECLUTCH VALVE MAINTENANCE

Removal, Disassembly, Cleaning, Inspection, Assembly, Installation, Adjustment

---

### INITIAL SETUP

**Maintenance Level**

Organizational

**Tools and Special Tools**

Tool kit, general mechanic's (Item 15, WP 0309)

Shop equipment, common no. 1 (Item 2, WP 0309)

**Materials/Parts**

Cleaning compound, solvent (Item 10, WP 0310)

Rag, wiping (Item 26, WP 0310)

Locknut

**Materials/Parts - Continued**

Lockwasher (2)

**References**

WP 0163

**Equipment Condition**

Engine OFF

Vehicle parked on level surface

Wheels blocked

Parking brake applied

Brake hoses, lines, and fittings disconnected from  
declutch valve (WP 0164)

---

**REMOVAL**

1. Remove two nuts (Figure 1, Item 1), lockwashers (Figure 1, Item 2), flat washers (Figure 1, Item 3), and capscrews (Figure 1, Item 4) from support bracket (Figure 1, Item 5). Discard lockwashers.
2. Remove support bracket (Figure 1, Item 5) and declutch valve (Figure 1, Item 10) from pedal bracket.

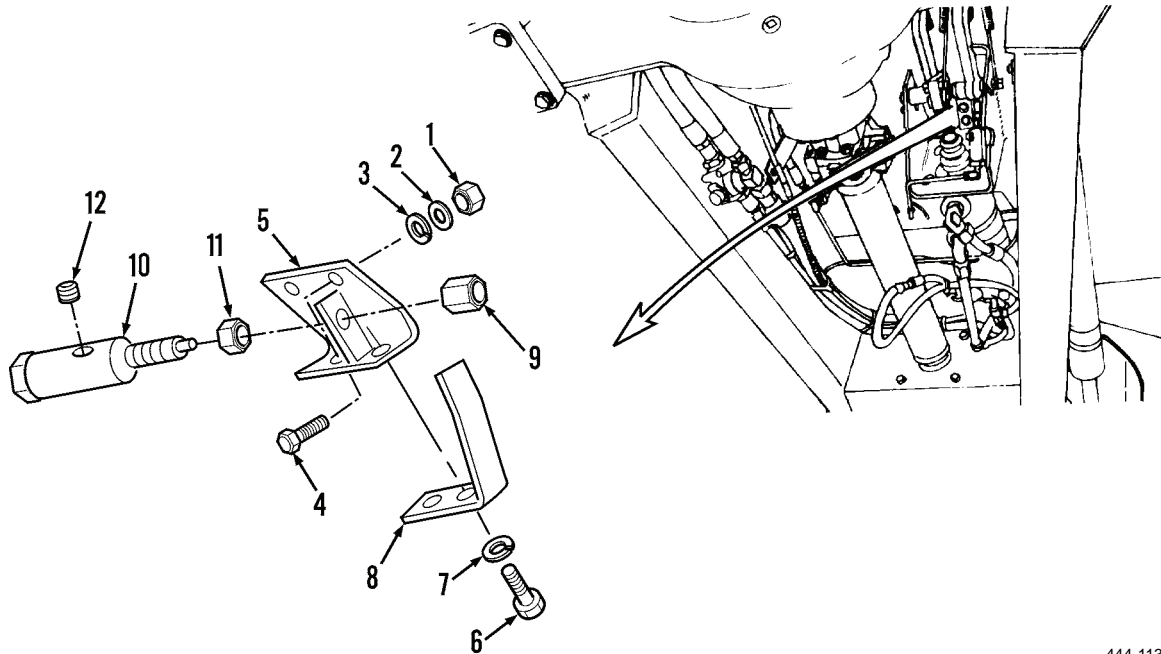

444-1137

**Figure 1. Declutch Valve Assembly.****END OF TASK****DISASSEMBLY**

1. Remove two screws (Figure 1, Item 6) and lockwashers (Figure 1, Item 7) from spring (Figure 1, Item 8), support bracket (Figure 1, Item 5), and declutch valve (Figure 1, Item 10). Discard lockwashers.
2. Remove flat spring (Figure 1, Item 8) from declutch valve (Figure 1, Item 10).
3. Remove nut (Figure 1, Item 9) from declutch valve (Figure 1, Item 10).
4. Remove declutch valve (Figure 1, Item 10) from support bracket (Figure 1, Item 5).
5. Remove locknut (Figure 1, Item 11) and pipe plug (Figure 1, Item 12) from declutch valve (Figure 1, Item 10). Discard locknut.

**END OF TASK**

**CLEANING****WARNING**

- Solvent cleaning compound MIL-PRF-680 Type III is an environmentally compliant and low toxic material. However, it may be irritating to the eyes and skin. Use protective gloves and goggles. Use in well-ventilated areas. Keep away from open flames and other sources of ignition. Failure to do so may result in injury or death to personnel.
- Particles blown by compressed air are hazardous. DO NOT exceed 15 PSI (103 kPa) nozzle pressure when drying parts with compressed air. DO NOT direct compressed air against human skin. Make sure air stream is directed away from user and other personnel in the area. To prevent injury, user must wear protective goggles or face shield. Failure to follow this warning may result in injury to personnel.

1. Wipe exterior of declutch valve (Figure 1, Item 10) and shaft with rag moistened in solvent cleaning compound.
2. Use solvent cleaning compound to clean all other parts. Dry thoroughly with compressed air.

**END OF TASK****INSPECTION**

1. Inspect spring (Figure 1, Item 8). Replace if cracked, distorted, or damaged.
2. Inspect all other parts. Replace if cracked, worn, or threads damaged.

**END OF TASK****ASSEMBLY****NOTE**

Remove and discard bleeder valve and washer supplied with new declutch valve.

1. Install pipe plug (Figure 1, Item 12) on declutch valve (Figure 1, Item 10).
2. Install new locknut (Figure 1, Item 11) on shaft of declutch valve (Figure 1, Item 10). Do not tighten locknut at this time.
3. Position declutch valve (Figure 1, Item 10) on support bracket (Figure 1, Item 5).
4. Install nut (Figure 1, Item 9) on shaft of declutch valve (Figure 1, Item 10). Do not tighten nut at this time.
5. Position flat spring (Figure 1, Item 8) on support bracket (Figure 1, Item 5).
6. Install two new lockwashers (Figure 1, Item 7) and screws (Figure 1, Item 6) and tighten screws until spring (Figure 1, Item 8) is securely mounted.

**END OF TASK**

**INSTALLATION**

1. Position support bracket (Figure 2, Item 5) and declutch valve (Figure 2, Item 10) on pedal bracket.
2. Install two capscrews (Figure 2, Item 4), washers (Figure 2, Item 3), new lockwashers (Figure 2, Item 2), and nuts (Figure 2, Item 1) on pedal bracket and support bracket (Figure 2, Item 5). Do not tighten nuts at this time.
3. Reconnect brake hoses, lines, and fittings to declutch valve (Figure 2, Item 10) (WP 0164).
4. Bleed brake system (refer to *Bleeding Brakes* in WP 0163).

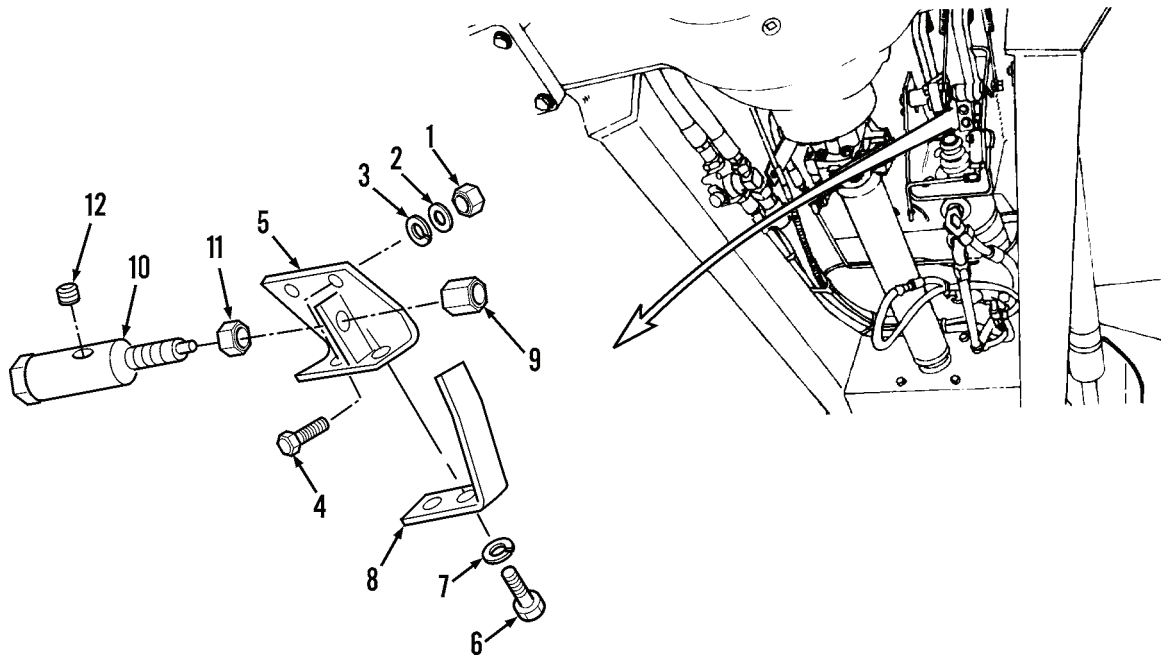

444-1137

**Figure 2. Declutch Valve Assembly.****END OF TASK**



## ADJUSTMENT

1. Position declutch valve (Figure 2, Item 10) on support bracket (Figure 2, Item 5) so valve plunger just makes contact with flat spring (Figure 2, Item 8) as shown in Figure 3.

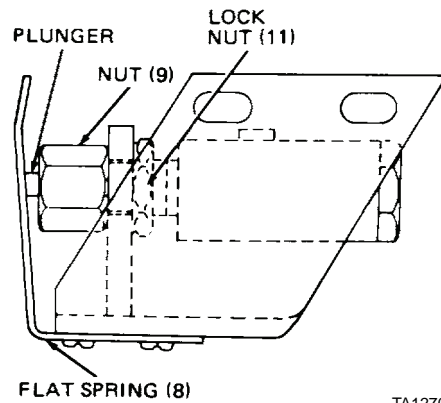

**Figure 3. Declutch Valve Support Bracket.**

2. Tighten nuts (Figure 2, Items 9 and 1) and locknut (Figure 2, Item 11) against support bracket (Figure 2, Item 5).
3. Gently pull flat spring (Figure 2, Item 8) from plunger and release to check adjustment. When released, flat spring should contact valve plunger without depressing plunger as shown in Figure 4.

## NOTE

If necessary, repeat steps 1 and 2, and recheck adjustment (step 3) before proceeding.

4. Position support bracket (Figure 2, Item 5) on pedal bracket so flat spring (Figure 2, Item 8) just makes contact with cam on declutch pedal without depressing valve plunger as shown in Figure 4.

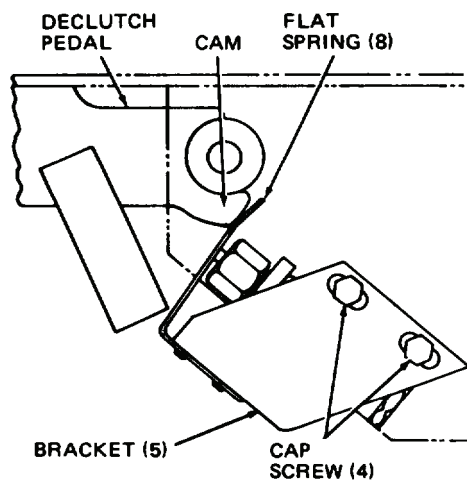

**Figure 4. Declutch Valve Pedal Bracket.**

5. Tighten two capscrews (Figure 2, Item 4) on support bracket (Figure 2, Item 5).

**END OF TASK**

**END OF WORK PACKAGE**



---

## ORGANIZATIONAL MAINTENANCE INSTRUCTIONS

### BRAKE PEDAL AND DECLUTCH PEDAL MAINTENANCE

Removal, Disassembly, Cleaning, Inspection, Assembly, Installation, Adjustment

---

#### INITIAL SETUP

##### Maintenance Level

Organizational

##### Tools and Special Tools

Tool kit, general mechanic's (Item 15, WP 0309)

Shop equipment, common no. 1 (Item 2, WP 0309)

Wood blocks (2), 6 x 6 x 18 in.

##### Materials/Parts

Cleaning compound, solvent (Item 10, WP 0310)

Grease, automotive and artillery (Item 17, WP 0310)

Rag, wiping (Item 26, WP 0310)

##### Materials/Parts - Continued

Cotter pin

Locknut (3)

Lockwasher

##### References

WP 0167

##### Equipment Condition

Engine OFF

Vehicle parked on level surface

Wheels blocked

Parking brake applied

Chassis floor plate removed (WP 0188)

---

**REMOVAL**

1. Remove cotter pin (Figure 1, Item 1) and clevis pin (Figure 1, Item 2). Discard cotter pin.
2. Use pliers to remove two springs (Figure 1, Item 3).
3. Remove nut (Figure 1, Item 4), lockwasher (Figure 1, Item 5), and capscrew (Figure 1, Item 6) from eye rod (Figure 1, Item 7). Discard lockwasher.
4. Remove eye rod (Figure 1, Item 7) from pivot pin (Figure 1, Item 8).
5. Remove pivot pin (Figure 1, Item 8) from pedals (Figure 1, Items 9 and 10).
6. Remove declutch pedal (Figure 1, Item 9) and brake pedal (Figure 1, Item 10) from vehicle.
7. Unscrew locknut (Figure 1, Item 11) from nut on brake valve push rod. Discard locknut.
8. Unscrew brake pedal yoke (Figure 1, Item 12) from brake valve push rod.

**END OF TASK****DISASSEMBLY**

1. Remove two grease fittings (Figure 1, Item 13) from pedals (Figure 1, Items 9 and 10).
2. Remove four locknuts (Figure 1, Item 14) and capscrews (Figure 1, Item 15). Discard locknuts.

**END OF TASK****CLEANING****WARNING**

- Solvent cleaning compound MIL-PRF-680 Type III is an environmentally compliant and low toxic material. However, it may be irritating to the eyes and skin. Use protective gloves and goggles. Use in well-ventilated areas. Keep away from open flames and other sources of ignition. Failure to do so may result in injury or death to personnel.
- Particles blown by compressed air are hazardous. DO NOT exceed 15 PSI (103 kPa) nozzle pressure when drying parts with compressed air. DO NOT direct compressed air against human skin. Make sure air stream is directed away from user and other personnel in the area. To prevent injury, user must wear protective goggles or face shield. Failure to follow this warning may result in injury to personnel.

Use solvent cleaning compound to clean all parts. Dry thoroughly with compressed air.

**END OF TASK****INSPECTION**

1. Inspect springs (Figure 1, Item 3). Replace if cracked, distorted, or coil broken.
2. Inspect pivot pin (Figure 1, Item 8), declutch pedal (Figure 1, Item 9), brake pedal (Figure 1, Item 10), yoke (Figure 1, Item 12), and pin (Figure 1, Item 2). Replace if worn, pitted, burred, or damaged.
3. Inspect all hardware. Replace if worn, or if threads damaged.

## INSPECTION - CONTINUED

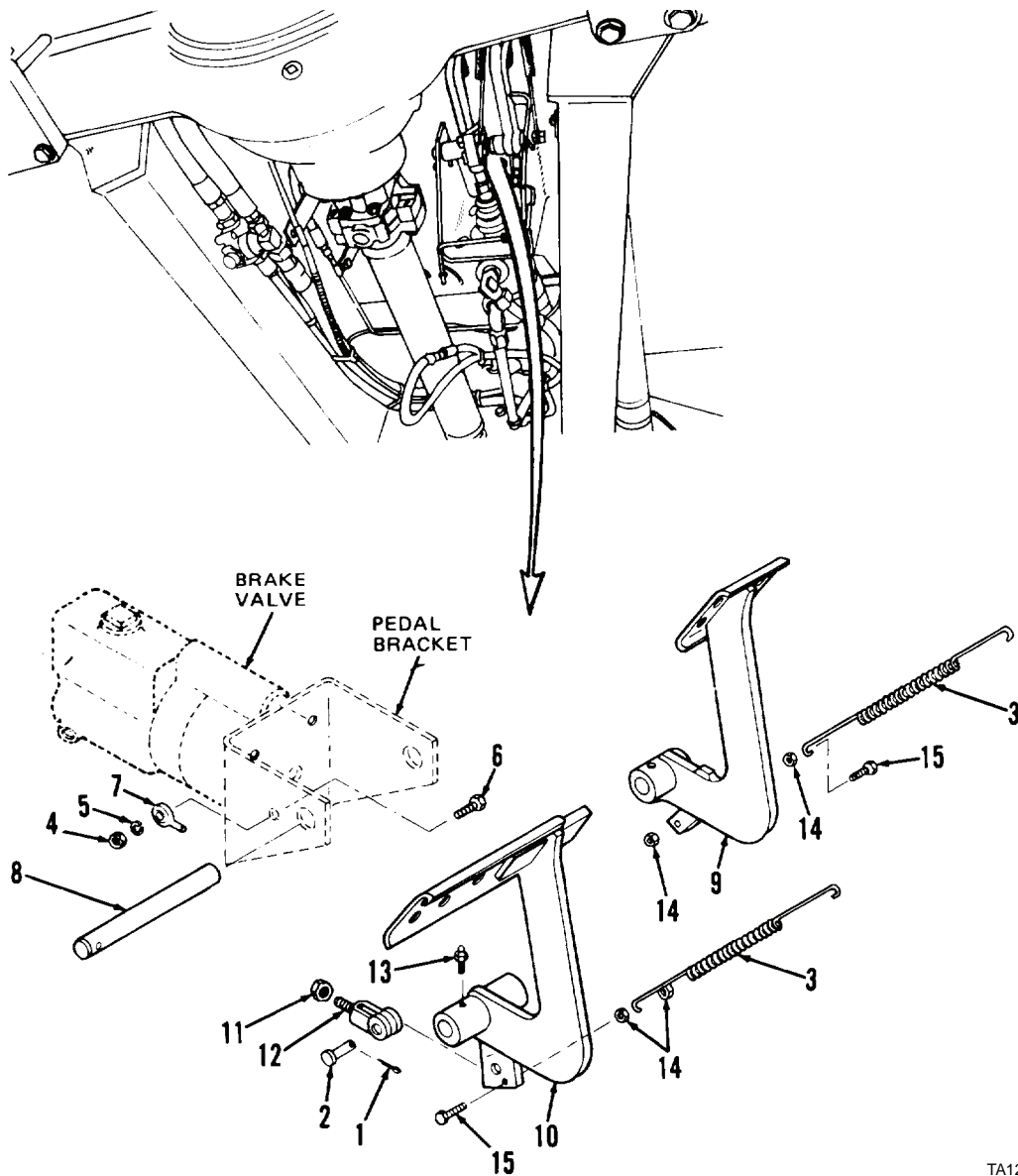

Figure 1. Brake Pedal and Declutch Pedal Assembly.

TA127010

## END OF TASK

## ASSEMBLY

1. Position two cap screws (Figure 1, Item 15) on pedal spring bracket.
2. Install four new locknuts (Figure 1, Item 14) and tighten until cap screws (Figure 1, Item 15) are securely mounted.
3. Install four new locknuts (Figure 1, Item 14) on end of cap screws (Figure 1, Item 15). Do not tighten against inside locknut or spring bracket on pedal.
4. Install two grease fittings (Figure 1, Item 13) and tighten until securely mounted.

## END OF TASK

**INSTALLATION**

1. Install new locknut (Figure 2, Item 11) on brake pedal yoke (Figure 2, Item 12). Do not tighten locknut at this time.
2. Install brake pedal yoke (Figure 2, Item 12) on brake valve push rod.
3. Install pedals (Figure 2, Items 9 and 10) and pivot pin (Figure 2, Item 8) on pedal bracket.
4. Position eye rod (Figure 2, Item 7) on brake valve.
5. Install capscrew (Figure 2, Item 6), new lockwasher (Figure 2, Item 5), and nut (Figure 2, Item 4) and tighten nut until eye rod (Figure 2, Item 7) is securely mounted.
6. Install two springs (Figure 2, Item 3) on pedals (Figure 2, Items 9 and 10).
7. Position brake pedal yoke (Figure 2, Item 12) on brake pedal (Figure 2, Item 10).
8. Install clevis pin (Figure 2, Item 2) and new cotter pin (Figure 2, Item 1) on yoke (Figure 2, Item 12) and brake pedal (Figure 2, Item 10).

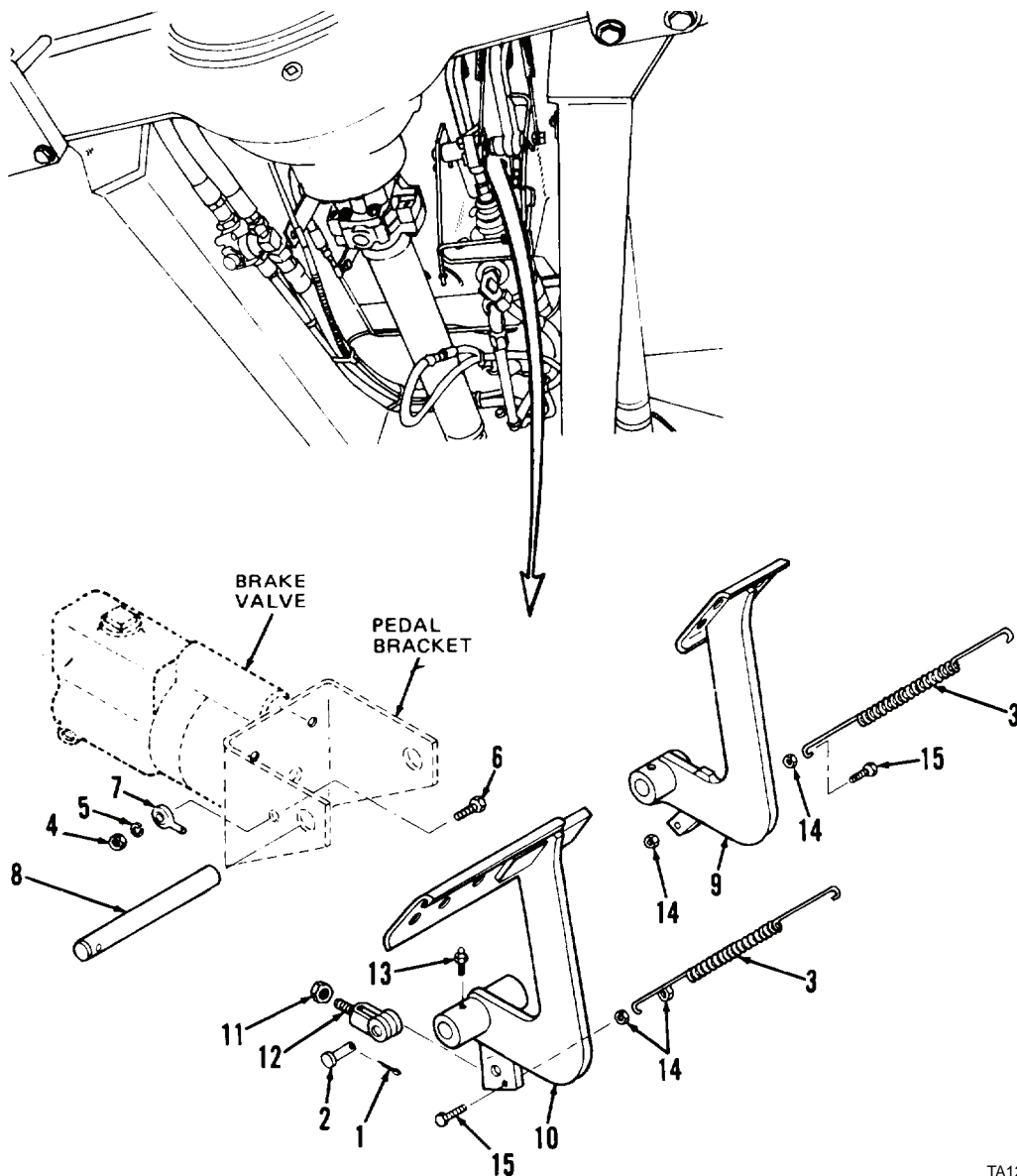

**Figure 2. Brake Pedal and Declutch Pedal Assembly.**

TA127010

**END OF TASK**

**ADJUSTMENT**

1. Adjust declutch valve and bracket (WP 0167).
2. Remove rubber cover from gland on hydraulic brake valve.
3. Adjust push rod in or out until free travel of brake pedal is 1/2 to 7/8 in. (13 to 22 mm) as shown in Figure 3.

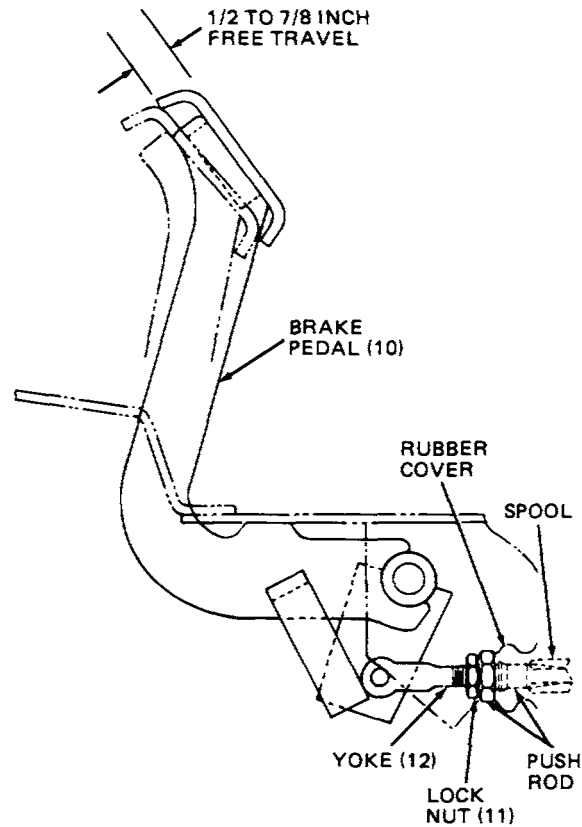

TA127011

**Figure 3. Brake Pedal Linkage and Travel.**

4. Tighten locknut (Figure 3, Item 11) against push rod.
5. Install rubber cover. Push large end of cover over groove at brake unit gland.

**END OF TASK****END OF WORK PACKAGE**





---

## ORGANIZATIONAL MAINTENANCE INSTRUCTIONS

### WHEELS AND TIRES MAINTENANCE

#### Removal, Disassembly, Cleaning, Inspection, Installation

---

#### INITIAL SETUP

##### Maintenance Level

Organizational

##### Tools and Special Tools

Tool kit, general mechanic's (Item 15, WP 0309)  
 Shop equipment, common no. 1 (Item 2, WP 0309)  
 Wood blocks (2), 6 x 6 x 18 in.

##### Materials/Parts

Brush, wire (Item 8, WP 0310)  
 Cleaning compound, solvent (Item 10, WP 0310)

##### Materials/Parts - Continued

Rag, wiping (Item 26, WP 0310)

##### References

TM 9-2610-200-24

##### Equipment Condition

Vehicle parked on level surface  
 Engine OFF  
 Parking brake applied  
 Wheels and tires not being removed blocked  
 Shipping lock pin installed (WP 0044)  
 Wheel and tire to be removed raised off ground

---



#### WARNING

Before raising wheel off ground, ensure shipping lock pin is installed. Failure to do so may cause vehicle to turn and slip off jack or jack stands, causing injury or death to personnel.

**REMOVAL**

1. Remove six stud nuts (Figure 1, Item 1) from wheel and tire assembly.
2. Remove wheel and tire assembly from vehicle.

**END OF TASK****DISASSEMBLY**

1. Remove valve cap (Figure 1, Item 2) from extension valve (Figure 1, Item 5).
2. Remove valve core (Figure 1, Item 3) from extension valve (Figure 1, Item 5) to deflate tire (Figure 1, Item 4).
3. Remove tire (Figure 1, Item 4) from wheel (Figure 1, Item 7) (TM 9-2610-200-24).
4. Remove extension valve (Figure 1, Item 5) and air valve (Figure 1, Item 6) from wheel (Figure 1, Item 7).

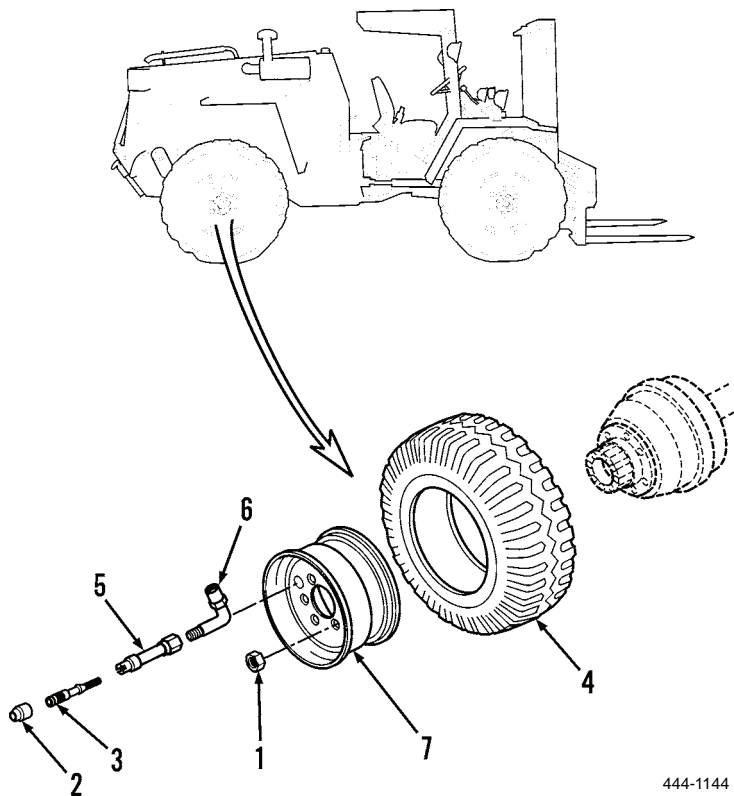

444-1144

**Figure 1. Wheel and Tire Assembly.****END OF TASK**

**CLEANING****WARNING**

Solvent cleaning compound MIL-PRF-680 Type III is an environmentally compliant and low toxic material. However, it may be irritating to the eyes and skin. Use protective gloves and goggles. Use in well-ventilated areas. Keep away from open flames and other sources of ignition. Failure to do so may result in injury or death to personnel.

1. Clean wheel with wire brush to remove rust, corrosion and particles of rubber. Clean wheel with solvent cleaning compound. Dry thoroughly.
2. Clean tire with water and wipe dry with clean rags.
3. Clean other parts with solvent cleaning compound. Dry thoroughly.

**END OF TASK****INSPECTION**

1. Inspect six stud nuts (Figure 1, Item 1). Replace if distorted or threads are damaged.
2. Inspect valve cap (Figure 1, Item 2), valve core (Figure 1, Item 3), extension valve (Figure 1, Item 5), and air valve (Figure 1, Item 6). Replace if bent, distorted, cracked, or threads are damaged.
3. Inspect tire (Figure 1, Item 4). Replace if tread is excessively worn, punctured, or casing is damaged.
4. Inspect wheel (Figure 1, Item 7). Replace if cracked, bent, or damaged.

**END OF TASK****ASSEMBLY**

1. Install air valve (Figure 1, Item 6) and extension valve (Figure 1, Item 5) on wheel (Figure 1, Item 7).
2. Install valve core (Figure 1, Item 3) on extension valve (Figure 1, Item 5).

**WARNING**

Do not overinflate tire. Injury or death to personnel could result.

3. Install tire (Figure 1, Item 4) on wheel (Figure 1, Item 7) and inflate to 45 PSI (310 kPa). (Refer to TM 9-2610-200-24 for mounting and inflation procedures.)

**END OF TASK****INSTALLATION**

1. Position wheel and tire assembly on studs at end of axle.
2. Install six stud nuts (Figure 1, Item 1) on studs and partially tighten stud nuts.
3. Lower wheel and tire assembly to the ground and alternately tighten six stud nuts (Figure 1, Item 1) to 240-260 lb-ft (325 to 353 Nm).

**END OF TASK****END OF WORK PACKAGE**



---

## ORGANIZATIONAL MAINTENANCE INSTRUCTIONS

### HYDRAULIC PUMP REPLACEMENT

#### Removal, Installation

---

#### INITIAL SETUP

**Maintenance Level**

Organizational

**Tools and Special Tools**

Tool kit, general mechanic's (Item 15, WP 0309)

Shop equipment, common no. 1 (Item 2, WP 0309)

**Materials/Parts**

Cap set, protective (Item 9, WP 0310)

Cleaning compound, solvent (Item 10, WP 0310)

Rag, wiping (Item 26, WP 0310)

Gasket

**Materials/Parts - Continued**

Lockwasher (2)

**References**

WP 0198

**Equipment Condition**

Vehicle parked on level surface

Engine OFF

Parking brake applied

Exhaust pipe removed (WP 0076 and WP 0077)

Top hood removed (WP 0180 and WP 0181)

Right side panel removed (WP 0179)

---

**REMOVAL****WARNING**

Solvent cleaning compound MIL-PRF-680 Type III is an environmentally compliant and low toxic material. However, it may be irritating to the eyes and skin. Use protective gloves and goggles. Use in well-ventilated areas. Keep away from open flames and other sources of ignition. Failure to do so may result in injury or death to personnel.

1. At right side of engine compartment, clean hydraulic pump (Figure 1, Item 8), hydraulic connections, and surface of transmission with solvent cleaning compound. Dry with clean rags.
2. Loosen hose clamp (Figure 1, Item 1).

**NOTE**

When disconnecting suction hose in step 3, be ready to plug it immediately to prevent loss of hydraulic oil.

3. Disconnect suction hose (Figure 1, Item 2) from hydraulic pump (Figure 1, Item 8). Plug suction hose and cap hydraulic pump.
4. Disconnect supply hose (Figure 1, Item 3) from connector (Figure 1, Item 4). Plug supply hose.
5. Remove connector (Figure 1, Item 4) from hydraulic pump (Figure 1, Item 8). Plug outlet of hydraulic pump.
6. While supporting hydraulic pump (Figure 1, Item 8), remove two capscrews (Figure 1, Item 5), lockwashers (Figure 1, Item 6), washers (Figure 1, Item 7), hydraulic pump, and gasket (Figure 1, Item 9) from transmission. Discard gasket and lockwashers.
7. Clean any remaining gasket material from transmission and hydraulic pump (Figure 1, Item 8).

**END OF TASK****INSTALLATION**

1. Install new gasket (Figure 1, Item 9) and hydraulic pump (Figure 1, Item 8) on transmission with two washers (Figure 1, Item 7), new lockwashers (Figure 1, Item 6), and capscrews (Figure 1, Item 5).
2. Install connector (Figure 1, Item 4) on outlet of hydraulic pump (Figure 1, Item 8).
3. Connect supply hose (Figure 1, Item 3) to connector (Figure 1, Item 4).
4. Connect suction hose (Figure 1, Item 2) to hydraulic pump (Figure 1, Item 8).
5. Tighten hose clamp (Figure 1, Item 1).
6. In operator's compartment, start engine and operate at idle speed while turning steering wheel to extreme right and left several times.
7. Increase engine speed and operate shift control lever to shift forks right and left several times.
8. Idle engine and check for oil leaks at hydraulic pump and connections.
9. Stop engine
10. At hydraulic oil reservoir, check hydraulic oil level. Add oil if necessary (WP 0198).

INSTALLATION - CONTINUED

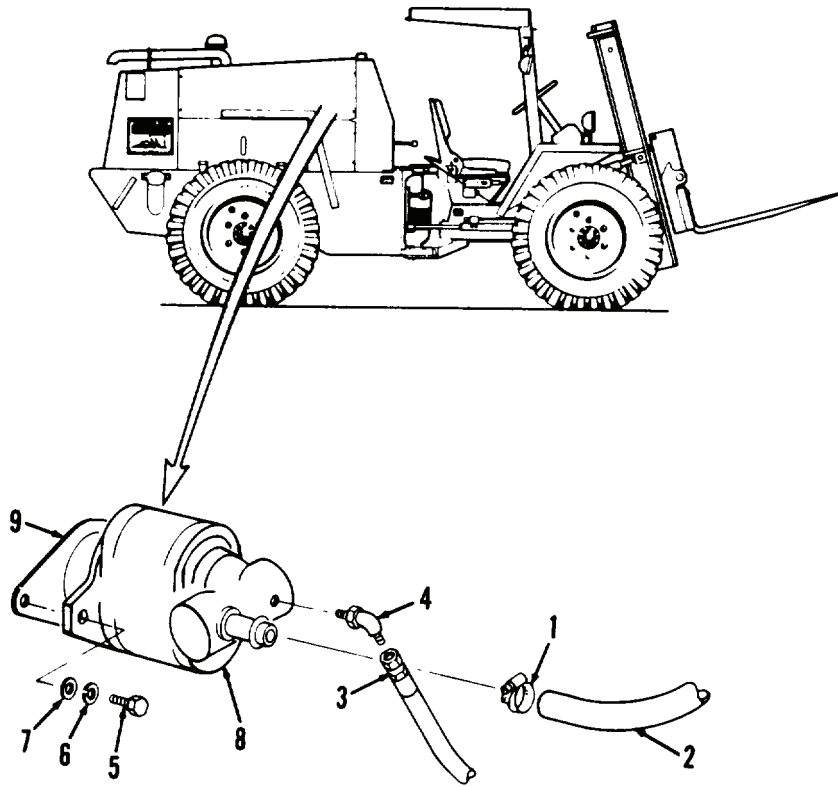

Figure 1. Hydraulic Pump Assembly.

END OF TASK

END OF WORK PACKAGE





---

## ORGANIZATIONAL MAINTENANCE INSTRUCTIONS

### STEERING HOSES, LINES, AND FITTINGS MAINTENANCE (STEERING GEAR TO STEERING CYLINDER)

Removal, Cleaning, Inspection, Installation, Adjustment

---

#### INITIAL SETUP

##### Maintenance Level

Organizational

##### Tools and Special Tools

Tool kit, general mechanic's (Item 15, WP 0309)

Shop equipment, common no. 1 (Item 2, WP 0309)

##### Materials/Parts

Cleaning compound, solvent (Item 10, WP 0310)

Lubricating oil, OE/HDO-10 (Item 20, WP 0310)

Rag, wiping (Item 26, WP 0310)

##### Materials/Parts - Continued

Strap, tiedown (Item 32, WP 0310)

Lockwasher

##### References

WP 0198

##### Equipment Condition

Vehicle parked on level surface

Engine OFF

Parking brake applied

Left and right side panels removed (WP 0179)

Noise baffle mat removed (WP 0187)

---

---

**REMOVAL**

1. At chassis, cut and remove two tiedown straps (Figure 1, Item 1). Discard tiedown straps.
2. Remove four hose clamps (Figure 1, Item 2).
3. Remove two steering cylinder guards (Figure 1, Item 3).
4. Disconnect four hose fittings (Figure 1, Item 4) of two steering supply hoses (Figure 1, Item 5).
5. Remove two steering supply hoses (Figure 1, Item 5) from vehicle.
6. Remove two elbows (Figure 1, Item 6).
7. Disconnect four hose fittings (Figure 1, Item 7) of two steering supply hoses (Figure 1, Item 8).
8. Remove two steering supply hoses (Figure 1, Item 8) from vehicle.
9. Remove two elbows (Figure 1, Item 9).
10. At front-right side of chassis, disconnect tube fittings (Figure 1, Items 10 and 11).
11. Remove nuts (Figure 1, Items 12 and 13) and remove two bulkhead unions (Figure 1, Item 14).
12. At bottom center of chassis, disconnect tube fitting (Figure 1, Item 15) and remove steering tube assembly (Figure 1, Item 16).
13. Disconnect tube fitting (Figure 1, Item 17) and remove steering tube assembly (Figure 1, Item 18).
14. At front-left side of chassis, remove nut (Figure 1, Item 19), lockwasher (Figure 1, Item 20), washer (Figure 1, Item 21), capscrew (Figure 1, Item 22), and clamps (Figure 1, Items 23 and 24). Discard lockwasher.
15. Disconnect tube fittings (Figure 1, Items 25 and 26) and remove steering bypass tube assembly (Figure 1, Item 27).
16. Disconnect tube fittings (Figure 1, Items 28 and 29) and remove steering bypass tube assembly (Figure 1, Item 30).
17. Remove connectors (Figure 1, Items 31 and 32).
18. At steering bypass valve, loosen stem nut (Figure 1, Item 33).
19. Remove valve stem (Figure 1, Item 34), nut (Figure 1, Item 35), and valve body (Figure 1, Item 36).
20. At steering gear in operator's compartment, disconnect tube fittings (Figure 1, Items 37, 38, and 39).
21. Disconnect tube fitting (Figure 1, Item 40) and remove steering return tube assembly (Figure 1, Item 41).
22. Remove two connectors (Figure 1, Item 42) and adapter (Figure 1, Item 43).
23. Disconnect tube fitting (Figure 1, Item 44) and remove steering supply tube assembly (Figure 1, Item 45).
24. Disconnect tube fitting (Figure 1, Item 46) and remove steering tube tee (Figure 1, Item 47).
25. Disconnect tube fitting (Figure 1, Item 48) and remove steering tube assembly (Figure 1, Item 49).
26. Disconnect tube fitting (Figure 1, Item 50) and remove steering supply tube assembly (Figure 1, Item 51).
27. Disconnect tube fitting (Figure 1, Item 52) and remove steering tube tee (Figure 1, Item 53).
28. Disconnect tube fitting (Figure 1, Item 54) and remove steering tube assembly (Figure 1, Item 55).
29. Remove two nuts (Figure 1, Item 56) and two bulkhead unions (Figure 1, Item 57).

REMOVAL - CONTINUED

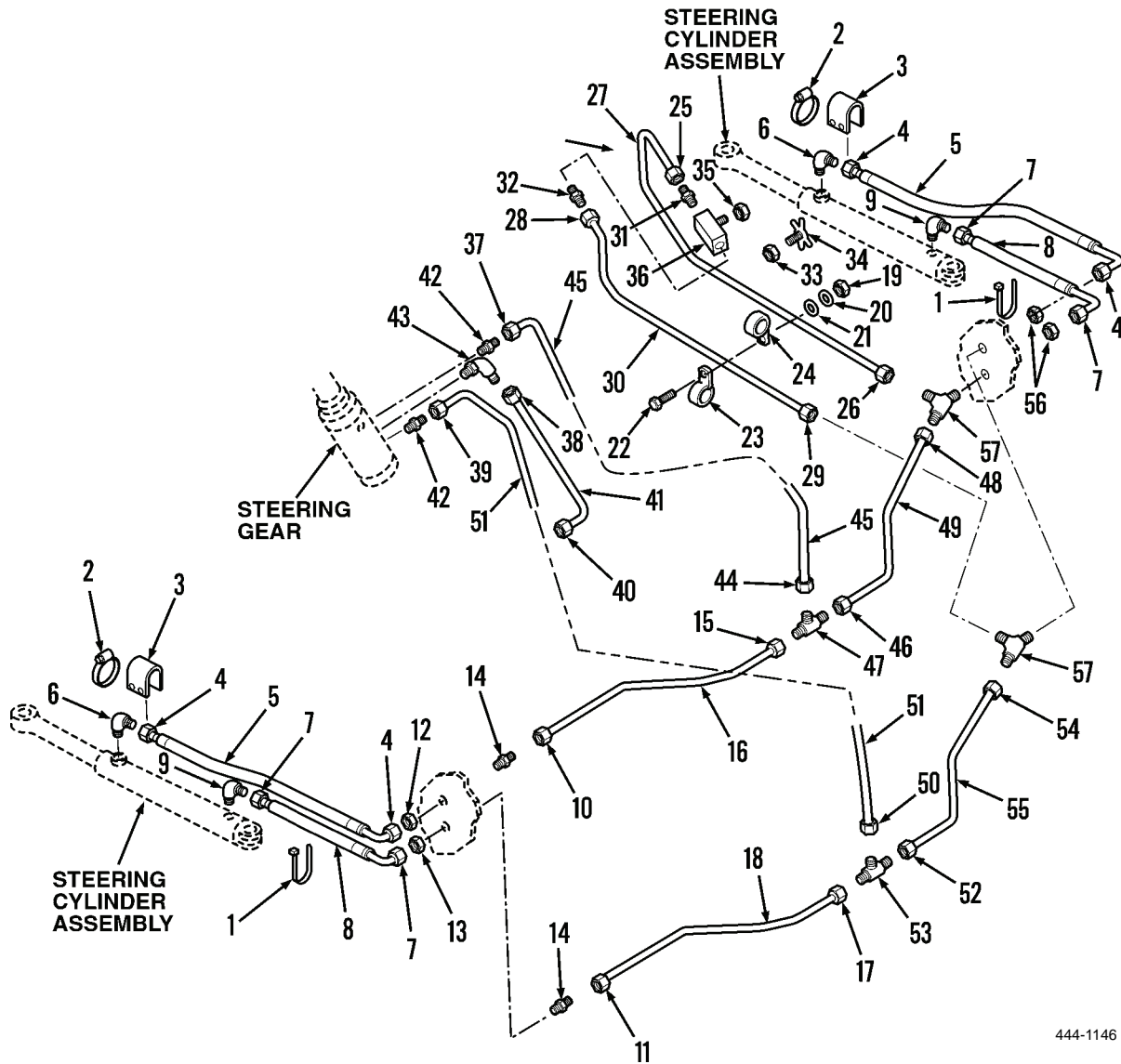

444-1146

Figure 1. Steering Hoses, Lines, and Fittings.

END OF TASK

**CLEANING****WARNING**

Solvent cleaning compound MIL-PRF-680 Type III is an environmentally compliant and low toxic material. However, it may be irritating to the eyes and skin. Use protective gloves and goggles. Use in well-ventilated areas. Keep away from open flames and other sources of ignition. Failure to do so may result in injury or death to personnel.

Clean all parts with solvent cleaning compound. Dry thoroughly

**END OF TASK****INSPECTION**

1. Inspect hoses. Replace if cracked, split, worn, or fittings are damaged.
2. Inspect tube assemblies. Replace if dented, or fittings are damaged.
3. Inspect all other parts. Replace if cracked or damaged.

**END OF TASK****INSTALLATION**

1. Install two bulkhead unions (Figure 2, Item 57) on vehicle with two nuts (Figure 2, Item 56).
2. Install steering tube assembly (Figure 2, Item 55) and connect fitting (Figure 2, Item 54).
3. Install steering tube tee (Figure 2, Item 53) and connect tube fitting (Figure 2, Item 52).
4. Install steering supply tube assembly (Figure 2, Item 51) and connect tube fitting (Figure 2, Item 50).
5. Install steering tube assembly (Figure 2, Item 49) and connect tube fitting (Figure 2, Item 48).
6. Install steering tube tee (Figure 2, Item 47) and connect tube fitting (Figure 2, Item 46).
7. Install steering supply tube assembly (Figure 2, Item 45) and connect tube fitting (Figure 2, Item 44).
8. Install adapter (Figure 2, Item 43) and two connectors (Figure 2, Item 42).
9. Install steering return tube assembly (Figure 2, Item 41) and connect tube fitting (Figure 2, Item 40).
10. Connect tube fittings (Figure 2, Items 39, 38, and 37).
11. Install valve body (Figure 2, Item 36), nut (Figure 2, Item 35), and valve stem (Figure 2, Item 34).
12. Tighten stem nut (Figure 2, Item 33).
13. Install connectors (Figure 2, Items 32 and 31).
14. Install steering bypass tube assembly (Figure 2, Item 30) and connect tube fittings (Figure 2, Items 29 and 28).
15. Install steering bypass tube assembly (Figure 2, Item 27) and connect tube fittings (Figure 2, Items 26 and 25).
16. Install clamps (Figure 2, Items 24 and 23) with capscrew (Figure 2, Item 22), washer (Figure 2, Item 21), new lockwasher (Figure 2, Item 20), and nut (Figure 2, Item 19).
17. Install steering tube assembly (Figure 2, Item 18) and connect tube fitting (Figure 2, Item 17).
18. Install steering tube assembly (Figure 2, Item 16) and connect tube fitting (Figure 2, Item 15).
19. Install two bulkhead unions (Figure 2, Item 14) with nuts (Figure 2, Items 13 and 12).
20. Connect tube fittings (Figure 2, Items 11 and 10).

**INSTALLATION - CONTINUED**

21. Install two elbows (Figure 2, Item 9).
22. Position two steering supply hoses (Figure 2, Item 8) on vehicle.
23. Connect four hose fittings (Figure 2, Item 7) of two steering supply hoses (Figure 2, Item 8).
24. Install two elbows (Figure 2, Item 6).
25. Position two steering supply hoses (Figure 2, Item 5) on vehicle.
26. Connect four hose fittings (Figure 2, Item 4) of two steering supply hoses (Figure 2, Item 5).
27. Install two steering cylinder guards (Figure 2, Item 3).
28. Install four hose clamps (Figure 2, Item 2).
29. Install two new tiedown straps (Figure 2, Item 1).
30. In operator's compartment, start engine and operate at idle speed while turning steering wheel to extreme right and left several times.

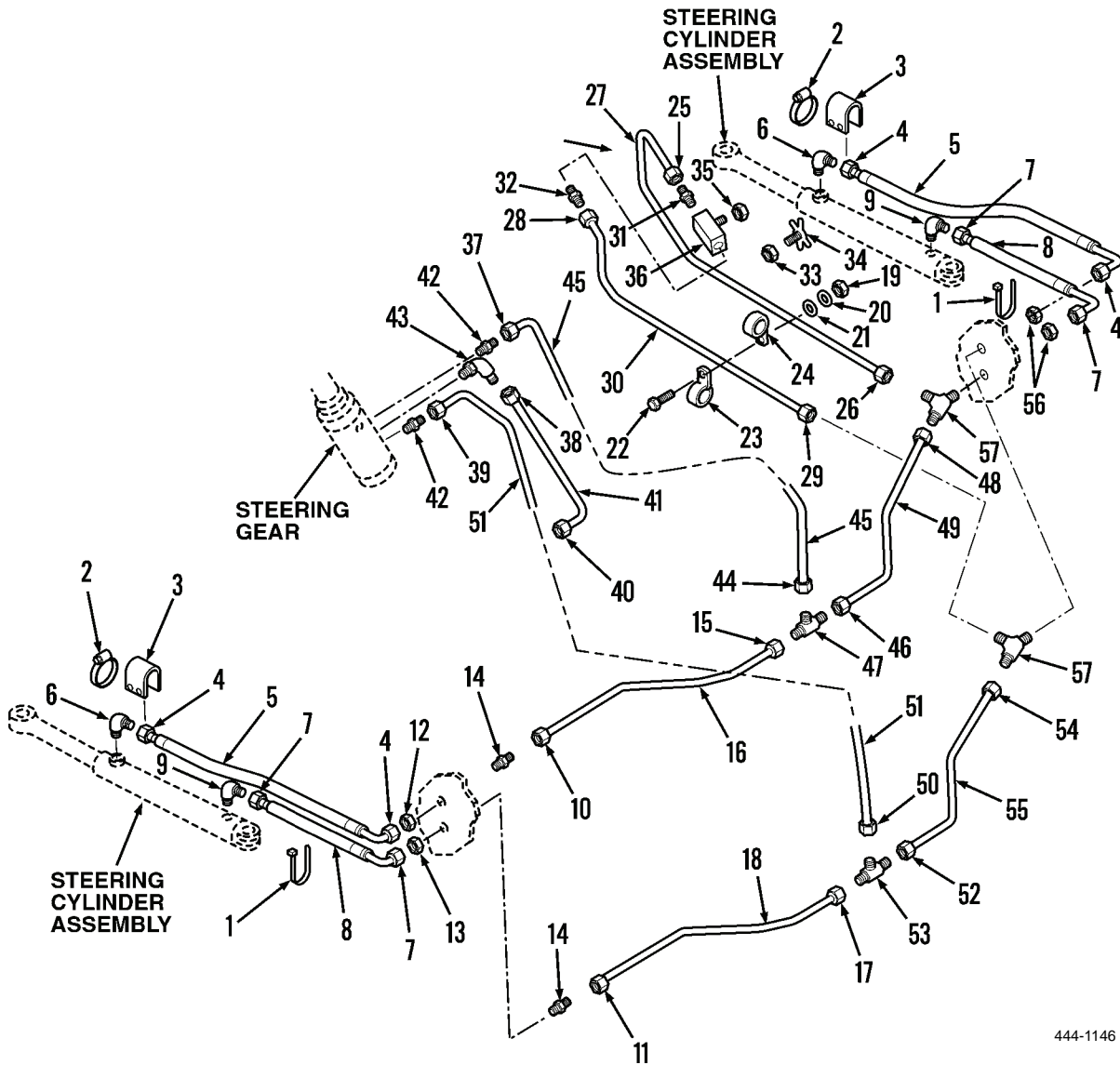

444-1146

**Figure 2. Steering Hoses, Lines, and Fittings.**

**INSTALLATION - CONTINUED**

31. Increase engine speed and operate shift control lever to shift forks right and left several times.
32. Idle engine and check for oil leaks at connections.
33. Stop engine.
34. At hydraulic oil reservoir, check hydraulic oil level. Add oil if necessary (WP 0198).

**END OF TASK****END OF WORK PACKAGE**

---

## ORGANIZATIONAL MAINTENANCE INSTRUCTIONS

### STEERING HOSES, LINES, AND FITTINGS MAINTENANCE (HYDRAULIC PUMP TO STEERING GEAR)

Removal, Cleaning, Inspection, Installation, Adjustment

---

#### INITIAL SETUP

##### Maintenance Level

Organizational

##### Tools and Special Tools

Tool kit, general mechanic's (Item 15, WP 0309)

Shop equipment, common no. 1 (Item 2, WP 0309)

Test stand, automotive (Item 12, WP 0309)

##### Materials/Parts

Cap set, protective (Item 9, WP 0310)

Cleaning compound, solvent (Item 10, WP 0310)

##### Materials/Parts - Continued

Lubricating oil, OE/HDO-10 (Item 20, WP 0310)

Rag, wiping (Item 26, WP 0310)

Lockwasher (3)

##### References

WP 0198

##### Equipment Condition

Vehicle parked on level surface

Engine OFF

Parking brake applied

Noise baffle mat removed (WP 0187)

---

**REMOVAL**

1. At steering gear in operator's compartment, disconnect hose fitting (Figure 1, Item 1) of hose (Figure 1, Item 13) from adapter (Figure 1, Item 2).
2. Remove adapter (Figure 1, Item 2) from steering gear.
3. Disconnect tube fitting (Figure 1, Item 3) of tube (Figure 1, Item 6) from connector (Figure 1, Item 4).
4. Disconnect tube fitting (Figure 1, Item 5) from control valve and remove tube (Figure 1, Item 6) from vehicle.
5. At bottom-right side of chassis, disconnect hose fitting (Figure 1, Item 7) of hose assembly (Figure 1, Item 8) from tee (Figure 1, Item 11). Plug hose.
6. Disconnect hose fitting (Figure 1, Item 9) of hose assembly (Figure 1, Item 10) from tee (Figure 1, Item 11). Plug hose.
7. Remove tee (Figure 1, Item 11) from relief valve (Figure 1, Item 28).
8. Disconnect hose fitting (Figure 1, Item 12) of hose assembly (Figure 1, Item 13) from adapter (Figure 1, Item 14).
9. Remove adapter (Figure 1, Item 14) from relief valve (Figure 1, Item 28).
10. Remove nut (Figure 1, Item 17), lockwasher (Figure 1, Item 18), washer (Figure 1, Item 19), capscrew (Figure 1, Item 20), and clamp (Figure 1, Item 21) from tube assembly (Figure 1, Item 22). Discard lockwasher.
11. Disconnect tube fittings (Figure 1, Items 15 and 16) of tube assembly (Figure 1, Item 22) from adapter (Figure 1, Item 23) and elbow (Figure 1, Item 30). Remove elbow.
12. Remove tube assembly (Figure 1, Item 22) from vehicle.
13. Remove adapter (Figure 1, Item 23) from relief valve (Figure 1, Item 28).
14. Remove two nuts (Figure 1, Item 24), lockwashers (Figure 1, Item 25), washers (Figure 1, Item 26), capscrews (Figure 1, Item 27), and relief valve (Figure 1, Item 28). Discard lockwashers.
15. At hydraulic brake valve, disconnect hose fitting (Figure 1, Item 29) of hose assembly (Figure 1, Item 32) from second elbow (Figure 1, Item 30). Remove elbow.
16. At hydraulic pump, disconnect hose fitting (Figure 1, Item 31) of hose assembly (Figure 1, Item 32) from connector (Figure 1, Item 33).
17. Remove hose assembly (Figure 1, Item 32) from vehicle.
18. Remove connector (Figure 1, Item 33) from hydraulic pump.

**NOTE**

Perform steps 19 through 21 if hose is to be removed.

19. Drain hydraulic oil reservoir (WP 0198).
20. Loosen two hose clamps (Figure 1, Item 34) and remove hose (Figure 1, Item 35) from elbow (Figure 1, Item 36) and hydraulic pump.
21. Remove elbow (Figure 1, Item 36) from bottom of hydraulic oil reservoir.



REMOVAL - CONTINUED

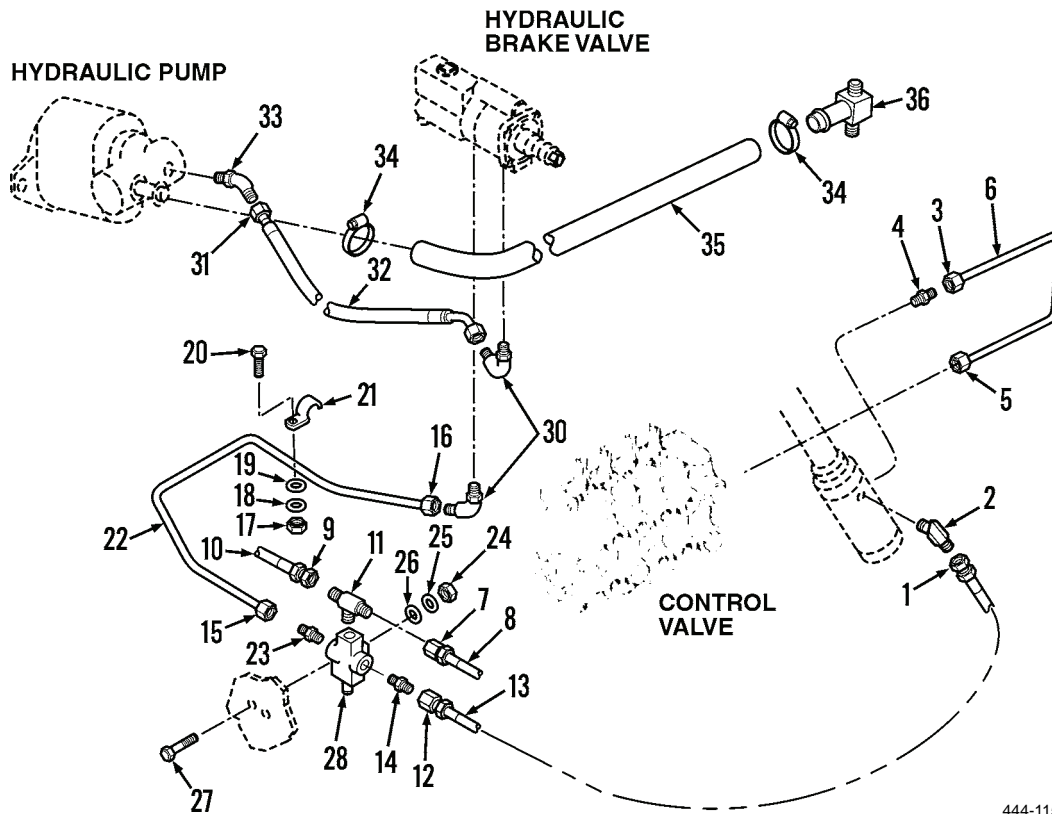

444-1153

Figure 1. Steering Hoses, Lines, and Fittings.

END OF TASK

CLEANING



WARNING

Solvent cleaning compound MIL-PRF-680 Type III is an environmentally compliant and low toxic material. However, it may be irritating to the eyes and skin. Use protective gloves and goggles. Use in well-ventilated areas. Keep away from open flames and other sources of ignition. Failure to do so may result in injury or death to personnel.

Clean all parts with solvent cleaning compound. Dry thoroughly.

END OF TASK

INSPECTION

1. Inspect hoses. Replace if cracked, split, worn, or fittings are damaged.
2. Inspect tube assemblies. Replace if dented or fittings are damaged.
3. Inspect all other parts. Replace if cracked or damaged.

END OF TASK

---

**INSTALLATION****NOTE**

Perform steps 1 through 3 if hose was removed.

1. Install elbow (Figure 2, Item 36) on bottom of hydraulic reservoir.
2. Install hose (Figure 2, Item 35) on elbow (Figure 2, Item 36) and hydraulic pump. Tighten two hose clamps (Figure 2, Item 34).
3. Fill hydraulic oil reservoir (WP 0198).
4. At hydraulic pump, install connector (Figure 2, Item 33) on hydraulic pump.
5. Position hose assembly (Figure 2, Item 32) on vehicle.
6. Connect hose fitting (Figure 2, Item 31) of hose assembly (Figure 2, Item 32) to connector (Figure 2, Item 33).
7. At hydraulic brake valve, install elbow (Figure 2, Item 30) and connect hose fitting (Figure 2, Item 29) of hose assembly (Figure 2, Item 32) to elbow.
8. Install relief valve (Figure 2, Item 28) on vehicle with two capscrews (Figure 2, Item 27), washers (Figure 2, Item 26), new lockwashers (Figure 2, Item 25), and nuts (Figure 2, Item 24).
9. Install adapter (Figure 2, Item 23) on relief valve.
10. Install second elbow (Figure 2, Item 30) on hydraulic brake valve.
11. Position tube assembly (Figure 2, Item 22) on vehicle.
12. Connect tube fittings (Figure 2, Items 15 and 16) of tube assembly (Figure 2, Item 22) to elbow (Figure 2, Item 30) and adapter (Figure 2, Item 23).
13. Install clamp (Figure 2, Item 21) on tube assembly (Figure 2, Item 22) with capscrew (Figure 2, Item 20), washer (Figure 2, Item 19), new lockwasher (Figure 2, Item 18), and nut (Figure 2, Item 17).
14. Install adapter (Figure 2, Item 14) on relief valve (Figure 2, Item 28).
15. Connect hose fitting (Figure 2, Item 12) of hose assembly (Figure 2, Item 13) to adapter (Figure 2, Item 14).
16. Install tee (Figure 2, Item 11) on relief valve (Figure 2, Item 28).
17. Connect hose fitting (Figure 2, Item 9) of hose assembly (Figure 2, Item 10) to tee (Figure 2, Item 11).
18. Connect hose fitting (Figure 2, Item 7) of hose assembly (Figure 2, Item 8) to tee (Figure 2, Item 11).
19. Position tube (Figure 2, Item 6) on vehicle and connect tube fitting (Figure 2, Item 5) to control valve.
20. Connect tube fitting (Figure 2, Item 3) of tube (Figure 2, Item 6) to connector (Figure 2, Item 4).
21. Install adapter (Figure 2, Item 2) on steering gear.
22. Connect hose fitting (Figure 2, Item 1) of hose (Figure 2, Item 13) to adapter (Figure 2, Item 2).
23. In operator's compartment, start engine and operate at idle speed while turning steering wheel to extreme right and left several times.
24. Increase engine speed and operate shift control lever to shift forks right and left several times.
25. Idle engine and check for oil leaks at connections.
26. Stop engine.
27. At hydraulic oil reservoir, check hydraulic oil level. Add oil if necessary (WP 0198).

INSTALLATION - CONTINUED

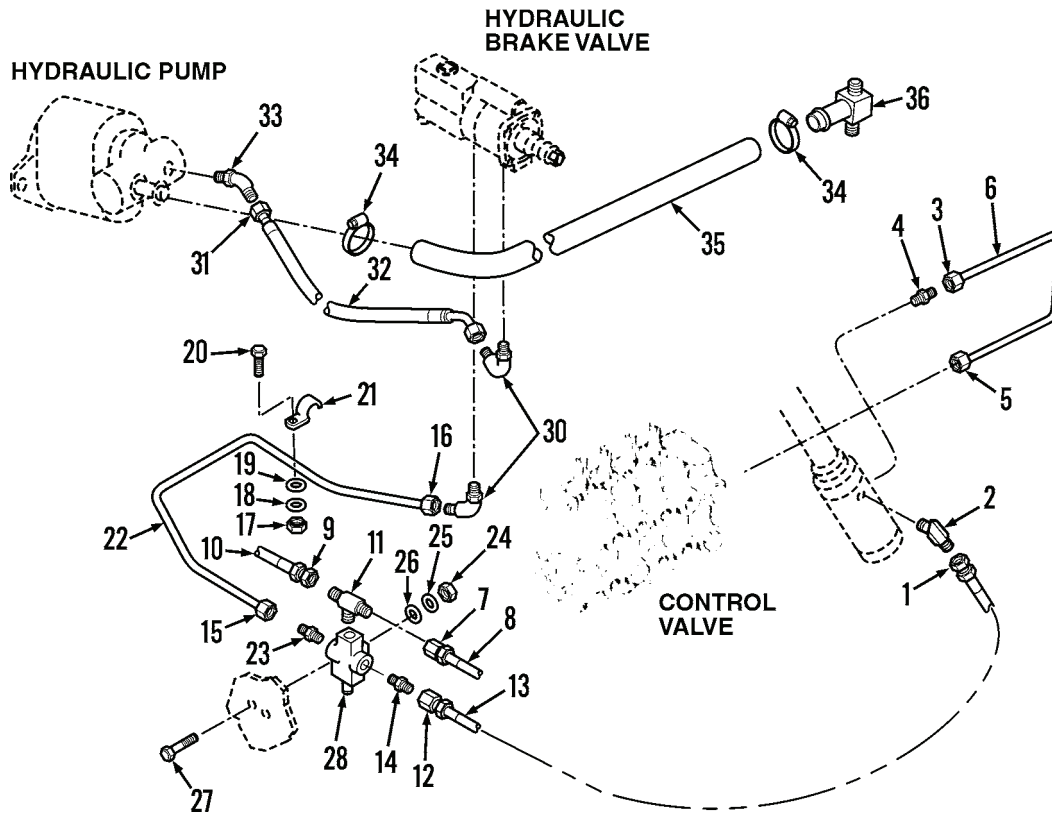

444-1153

Figure 2. Steering Hoses, Lines, and Fittings.

END OF TASK

## ADJUSTMENT

## NOTE

Perform the following steps to adjust hydraulic system to proper pressure.

1. Ensure engine is OFF.
2. In operator's compartment, operate all hydraulic control levers of control valve several times to relieve hydraulic system pressure.
3. At hydraulic pump in engine compartment, remove either plug or cap and install a hydraulic pressure gage (Figure 3).

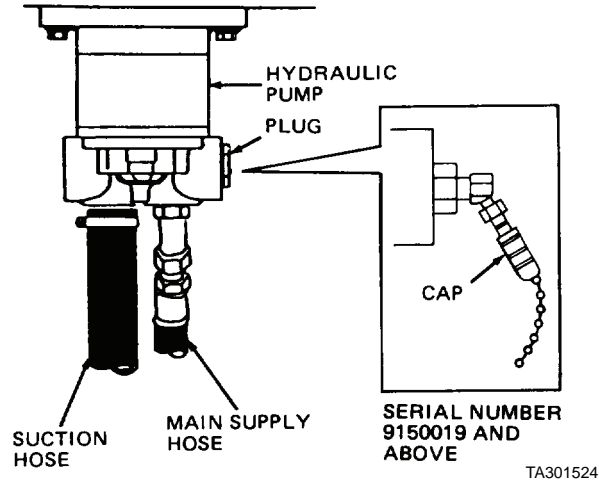

Figure 3. Hydraulic Pressure Adjustment.

## NOTE

Step 4 will warm the hydraulic oil.

4. Start engine and hold lift control lever toward you until tube shown at hydraulic control valve is warm to touch (Figure 4).

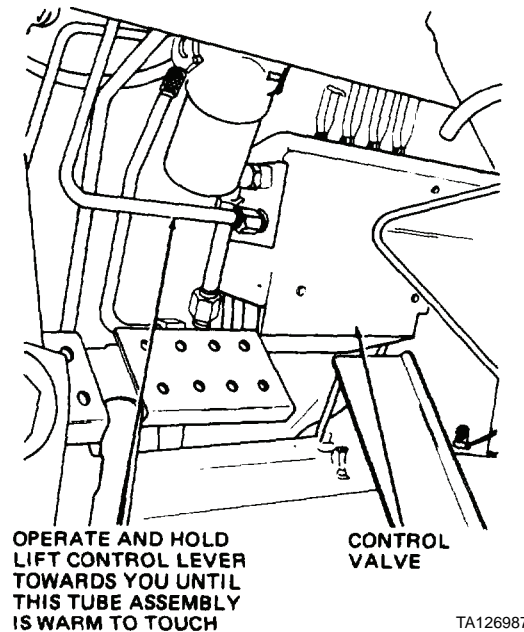

Figure 4. Tube at Hydraulic Control Valve.

**ADJUSTMENT - CONTINUED**

5. While continuing to hold lift control lever toward you, operate engine at full throttle and observe pressure gage reading. Gage should indicate 2,500 to 2,550 PSI (17,237 to 17,582 kPa) at 2,150 to 2,250 RPM. Return engine to idle speed.

**NOTE**

If pressure indication on gage was NOT correct, perform the following steps.

6. At relief valve, located at bottom-right side of chassis, remove nut and seal washer. Then loosen jam nut (Figure 5).
7. Repeat step 3 and rotate adjusting screw of relief valve until proper indication is obtained. Stop engine.
8. Tighten jam nut and install seal washer and nut.

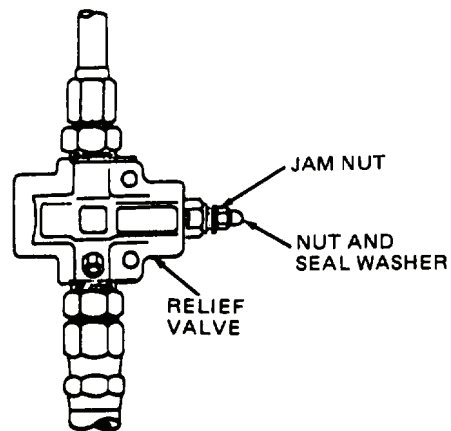

TA127026

**Figure 5. Relief Valve Adjustment.**

9. Repeat steps 1 and 2.
10. Remove hydraulic pressure gage and install cap or plug on hydraulic pump.

**END OF TASK****END OF WORK PACKAGE**



# ORGANIZATIONAL MAINTENANCE INSTRUCTIONS

## STEERING CYLINDER REPLACEMENT

### Removal, Cleaning, Inspection, Installation

#### INITIAL SETUP

##### Maintenance Level

Organizational

##### Tools and Special Tools

Tool kit, general mechanic's (Item 15, WP 0309)  
 Shop equipment, common no. 1 (Item 2, WP 0309)  
 Chain hoist, 1/4-ton capacity  
 Thread cutting tap, 9/16-18 UNF

##### Materials/Parts

Cap set, protective (Item 9, WP 0310)  
 Cleaning compound, solvent (Item 10, WP 0310)

##### Materials/Parts - Continued

Grease, automotive and artillery (Item 17, WP 0310)  
 Rag, wiping (Item 26, WP 0310)  
 Strap, tiedown (Item 32, WP 0310)

##### References

WP 0204

##### Equipment Condition

Vehicle parked on level surface  
 Engine OFF  
 Parking brake applied  
 Shipping lock pin installed (WP 0044)

#### REMOVAL



**WARNING**



Solvent cleaning compound MIL-PRF-680 Type III is an environmentally compliant and low toxic material. However, it may be irritating to the eyes and skin. Use protective gloves and goggles. Use in well-ventilated areas. Keep away from open flames and other sources of ignition. Failure to do so may result in injury or death to personnel.

#### NOTE

Perform the following steps to remove each of two steering cylinders.

**REMOVAL - CONTINUED**

1. At side of vehicle, clean steering cylinder (Figure 1, Item 12) and hydraulic connections with solvent cleaning compound. Dry with clean rags.
2. Cut and remove tiedown strap (Figure 1, Item 1). Discard tiedown strap.
3. Loosen and remove two hose clamps (Figure 1, Item 2) and steering cylinder guard (Figure 1, Item 3).
4. Disconnect hose fitting (Figure 1, Item 4) from elbow (Figure 1, Item 5). Plug hose fitting.
5. Remove elbow (Figure 1, Item 5) from steering cylinder (Figure 1, Item 12). Plug opening in steering cylinder.
6. Disconnect hose fitting (Figure 1, Item 6) from elbow (Figure 1, Item 7). Plug hose fitting.
7. Remove elbow (Figure 1, Item 7) from steering cylinder (Figure 1, Item 12). Plug opening in steering cylinder.
8. While supporting steering cylinder (Figure 1, Item 12), remove retaining ring (Figure 1, Item 8), pin (Figure 1, Item 9), retaining ring (Figure 1, Item 10), pin (Figure 1, Item 11), and steering cylinder from vehicle.

**END OF TASK****CLEANING****WARNING**

Solvent cleaning compound MIL-PRF-680 Type III is an environmentally compliant and low toxic material. However, it may be irritating to the eyes and skin. Use protective gloves and goggles. Use in well-ventilated areas. Keep away from open flames and other sources of ignition. Failure to do so may result in injury or death to personnel.

Clean each end of steering cylinder with solvent cleaning compound. Dry with clean rags.

**END OF TASK****INSPECTION**

1. Inspect hose clamps (Figure 1, Item 2) and steering cylinder guard (Figure 1, Item 3). Replace if damaged.
2. Inspect pins (Figure 1, Items 9 and 11). Replace if worn or damaged.
3. Inspect steering cylinder (Figure 1, Item 12). Replace if damaged.
4. Inspect threaded openings in steering cylinder (Figure 1, Item 12). If threads are distorted, chase threads with thread cutting tap.
5. Inspect other parts. Replace if damaged.

**END OF TASK****INSTALLATION**

1. Apply thin coat of grease to surface of pins (Figure 1, Items 9 and 11).
2. While supporting steering cylinder (Figure 1, Item 12), install steering cylinder on vehicle with pin (Figure 1, Item 11), retaining ring (Figure 1, Item 10), pin (Figure 1, Item 9), and retaining ring (Figure 1, Item 8).
3. Install elbows (Figure 1, Items 7 and 5) on steering cylinder (Figure 1, Item 12).
4. Connect hose fitting (Figure 1, Item 6) to elbow (Figure 1, Item 7).



**INSTALLATION - CONTINUED**

5. Connect hose fitting (Figure 1, Item 4) to elbow (Figure 1, Item 5).
6. Install steering cylinder guard (Figure 1, Item 3) on steering cylinder (Figure 1, Item 12) with two hose clamps (Figure 1, Item 2).
7. Install new tiedown strap (Figure 1, Item 1).
8. In operator's compartment, start engine and operate at idle speed while turning steering wheel to extreme right and left several times.
9. At hydraulic oil reservoir, check hydraulic oil level. Add oil if necessary (WP 0198).

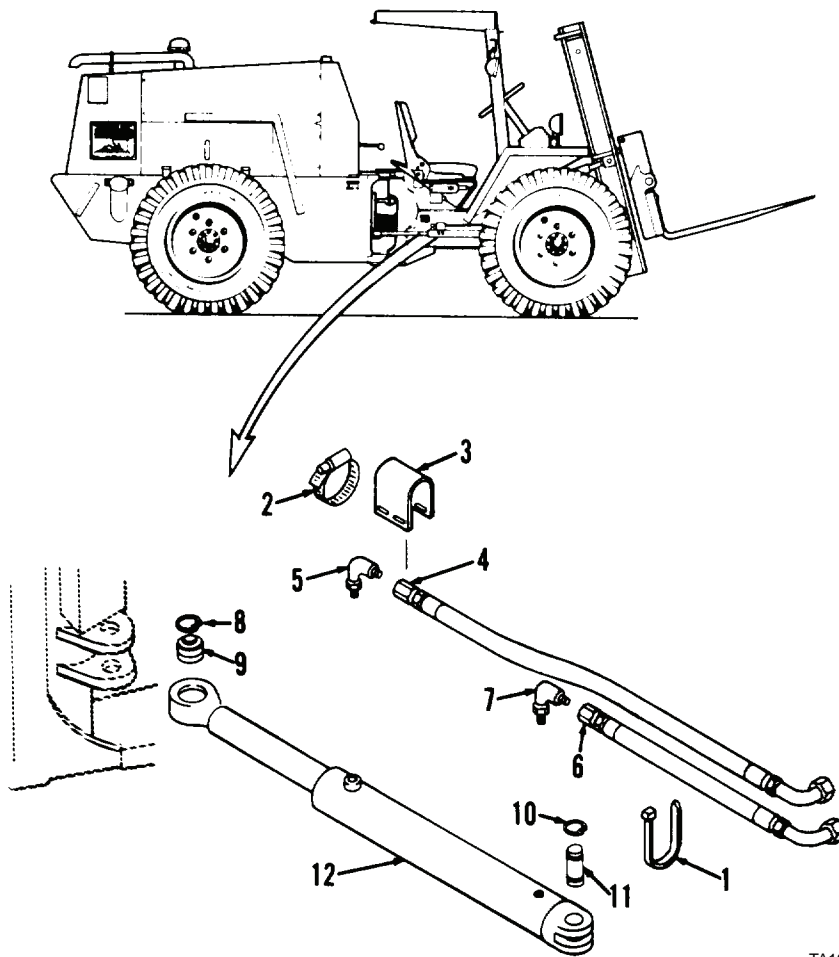

TA127027

**Figure 1. Steering Cylinder.****END OF TASK****END OF WORK PACKAGE**



---

## ORGANIZATIONAL MAINTENANCE INSTRUCTIONS

### ROLLOVER PROTECTIVE STRUCTURE REPLACEMENT

#### Removal, Cleaning, Inspection, Installation

---

#### INITIAL SETUP

**Maintenance Level**

Organizational

**Tools and Special Tools**

Tool kit, general mechanic's (Item 15, WP 0309)

Shop equipment, common no. 1 (Item 2, WP 0309)

Hoist, 1/2-ton capacity

**Materials/Parts**

Adhesive, vinyl (Item 3, WP 0310)

Cleaning compound, solvent (Item 10, WP 0310)

Rag, wiping (Item 26, WP 0310)

**Materials/Parts - Continued**

Lockwasher (4)

**Personnel Required**

Two

**Equipment Condition**

Engine OFF

Parking brake applied

Front floodlights removed (WP 0111 and WP 0112)

Front blackout light removed (WP 0113)

Noise baffle mat removed (WP 0187)

---

**REMOVAL**

1. At front floor of operator's compartment, disconnect two wire connectors at left side, and one connector at right side.
2. Attach hoist to top of rollover protective structure (ROPS) (Figure 1, Item 9) and take up slack.
3. Remove two nuts (Figure 1, Item 1), washers (Figure 1, Item 2), reinforcing plates (Figure 1, Item 3), washers (Figure 1, Item 4), and capscrews (Figure 1, Item 5).
4. Remove two nuts (Figure 1, Item 6), lockwashers (Figure 1, Item 7), and capscrews (Figure 1, Item 8). Discard lockwashers.
5. Remove ROPS (Figure 1, Item 9) from vehicle.
6. Remove two nuts (Figure 1, Item 10), lockwashers (Figure 1, Item 11), washers (Figure 1, Item 12), capscrews (Figure 1, Item 13), and brackets (Figure 1, Item 14). Discard lockwashers.

**NOTE**

Do not perform step 7 unless inspection indicates replacement of canopy headlining is necessary.

7. Remove headlining (Figure 1, Item 15) from ROPS (Figure 1, Item 9).

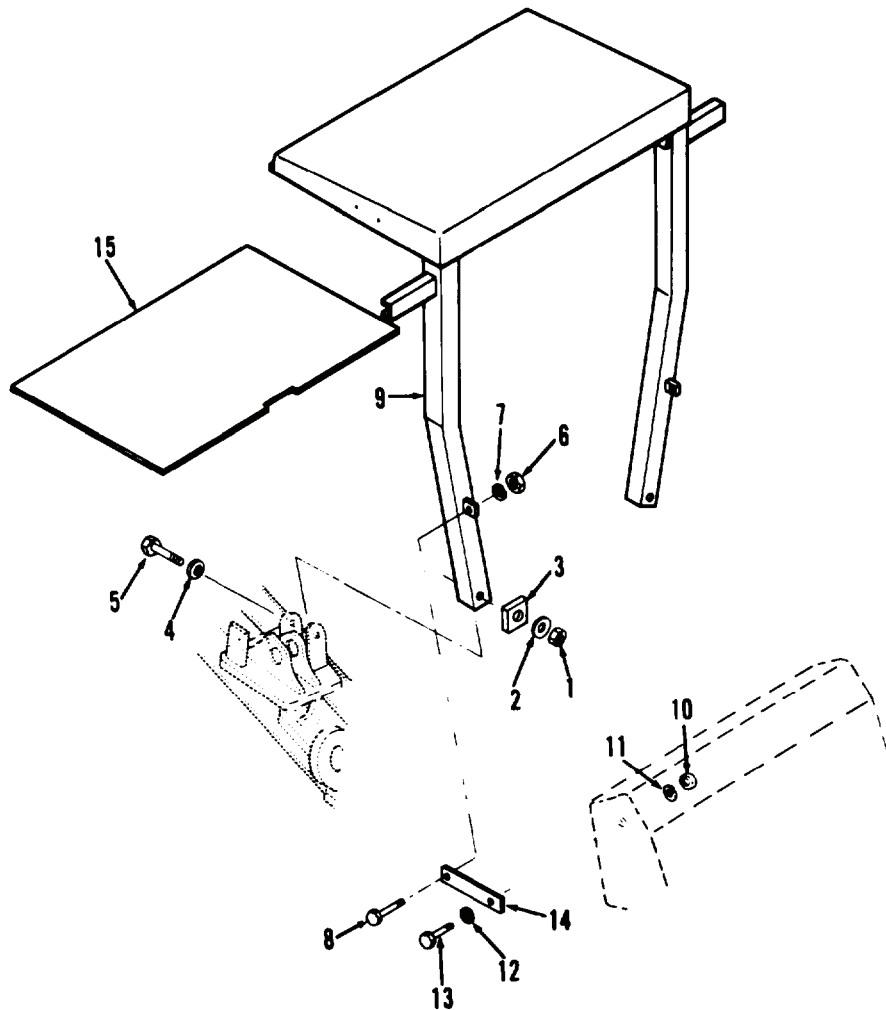

TA127028

**Figure 1. Rollover Protective Structure.**

**END OF TASK**

**CLEANING****WARNING**

Solvent cleaning compound MIL-PRF-680 Type III is an environmentally compliant and low toxic material. However, it may be irritating to the eyes and skin. Use protective gloves and goggles. Use in well-ventilated areas. Keep away from open flames and other sources of ignition. Failure to do so may result in injury or death to personnel.

Clean all parts with solvent cleaning compound. Dry with clean rags.

**END OF TASK****INSPECTION****WARNING**

ROPS must be replaced if bent, broken or welds show cracks or breaks. No repair of any kind is authorized. Failure to follow this warning could result in injury or death to personnel.

1. Inspect ROPS. Replace if bent, broken, or welds show cracks or breaks.
2. Inspect canopy headlining. Replace if portions are missing.
3. Inspect all other parts. Replace if cracked, bent, or threads are damaged.

**END OF TASK****INSTALLATION**

1. Install headlining (Figure 1, Item 15) on ROPS (Figure 1, Item 9), if removed. Use vinyl adhesive.
2. Install two brackets (Figure 1, Item 14) on ROPS (Figure 1, Item 9) with two capscrews (Figure 1, Item 13), washers (Figure 1, Item 12), new lockwashers (Figure 1, Item 11), and nuts (Figure 1, Item 10).
3. Attach hoist to top of ROPS (Figure 1, Item 9) and position ROPS on vehicle.
4. Install two capscrews (Figure 1, Item 8), new lockwashers (Figure 1, Item 7), and nuts (Figure 1, Item 6).
5. Install two capscrews (Figure 1, Item 5), washers (Figure 1, Item 4), reinforcing plates (Figure 1, Item 3), washers (Figure 1, Item 2), and nuts (Figure 1, Item 1). Tighten nuts to 290 to 300 lb-ft (393 to 407 Nm). Remove hoist.
6. At front floor of operator's compartment, connect one wire connector at right side and two connectors at left side.

**END OF TASK****END OF WORK PACKAGE**



---

## ORGANIZATIONAL MAINTENANCE INSTRUCTIONS

### CHASSIS STOP BUMPER REPLACEMENT

Removal, Installation

---

#### INITIAL SETUP

**Maintenance Level**

Organizational

**Tools and Special Tools**

Tool kit, general mechanic's (Item 15, WP 0309)

Shop equipment, common no. 1 (Item 2, WP 0309)

**Materials/Parts**

Lockwasher (2)

**Equipment Condition**

Vehicle parked on level surface

Engine OFF

Parking brake applied

---

**REMOVAL****NOTE**

Perform this procedure to remove each of two chassis stop bumpers.

At rear of operator's compartment, remove two nuts (Figure 1, Item 1), lockwashers (Figure 1, Item 2), and chassis stop bumper (Figure 1, Item 3). Discard lockwashers.

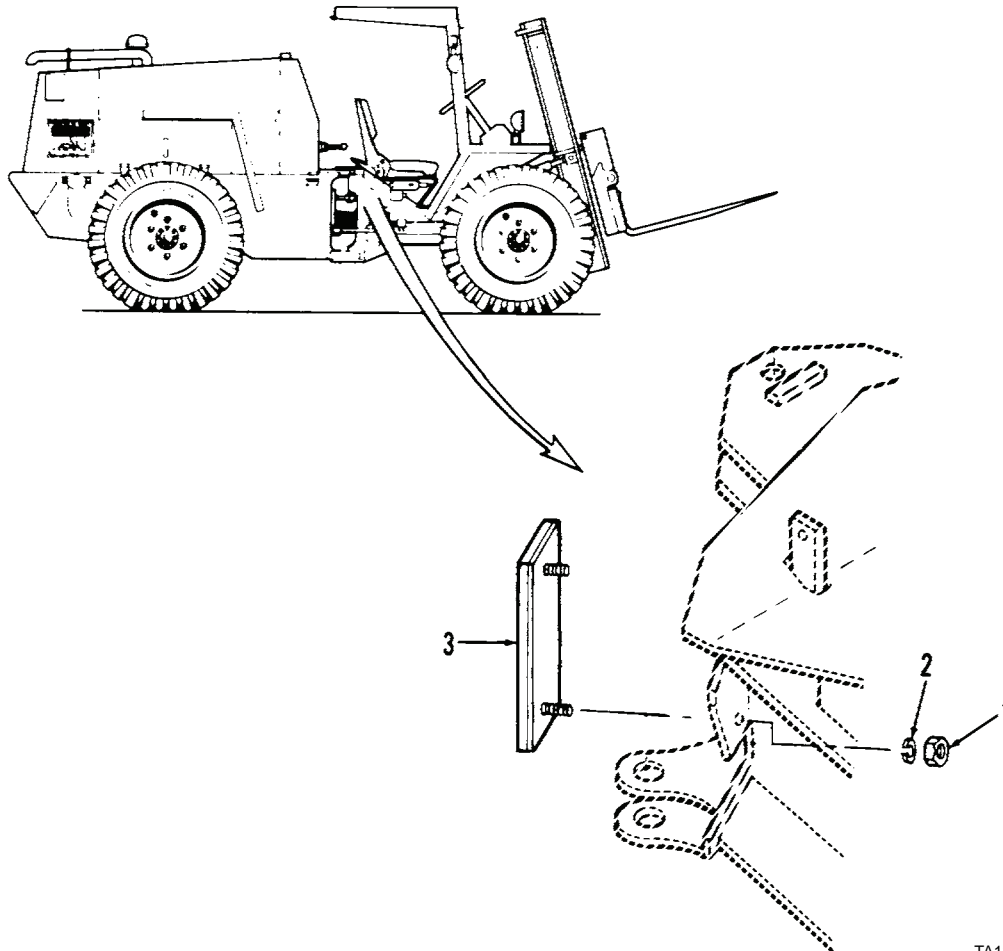

TA127029

**Figure 1. Chassis Stop Bumper.**

**END OF TASK****INSTALLATION****NOTE**

Perform this procedure to install each of two chassis stop bumpers.

At rear of operator's compartment, install chassis stop bumper (Figure 1, Item 3) with two new lockwashers (Figure 1, Item 2) and nuts (Figure 1, Item 1).

**END OF TASK****END OF WORK PACKAGE**



---

# ORGANIZATIONAL MAINTENANCE INSTRUCTIONS

## TOW BAR, TOW CHAINS, AND PINTLE HOOK REPLACEMENT

### Removal, Cleaning, Inspection, Installation

---

#### INITIAL SETUP

**Maintenance Level**

Organizational

**Tools and Special Tools**

Tool kit, general mechanic's (Item 15, WP 0309)

Shop equipment, common no. 1 (Item 2, WP 0309)

**Materials/Parts**

Cleaning compound, solvent (Item 10, WP 0310)

**Materials/Parts - Continued**

Rag, wiping (Item 26, WP 0310)

Lockwasher (4)

**References**

WP 0132

**Equipment Condition**

Vehicle parked on level surface

Engine OFF

Parking brake applied

---

**REMOVAL**

1. At rear of vehicle, remove pin and lower tow bar (Figure 1, Item 5) to ground.
2. Remove two nuts (Figure 1, Item 1), washers (Figure 1, Item 2), capscrews (Figure 1, Item 3), washers (Figure 1, Item 4), and tow bar (Figure 1, Item 5) from vehicle.
3. Unhook two chains (Figure 1, Item 8) and lay chains on ground.
4. Remove two nuts (Figure 1, Item 6), capscrews (Figure 1, Item 7), and chains (Figure 1, Item 8) from vehicle.
5. Move grille latch knob left and swing grille outward.
6. Remove battery cover (WP 0132).
7. While supporting pintle hook (Figure 1, Item 12), remove four nuts (Figure 1, Item 9), lockwashers (Figure 1, Item 11), capscrews (Figure 1, Item 10), and pintle hook from vehicle. Discard lockwashers.

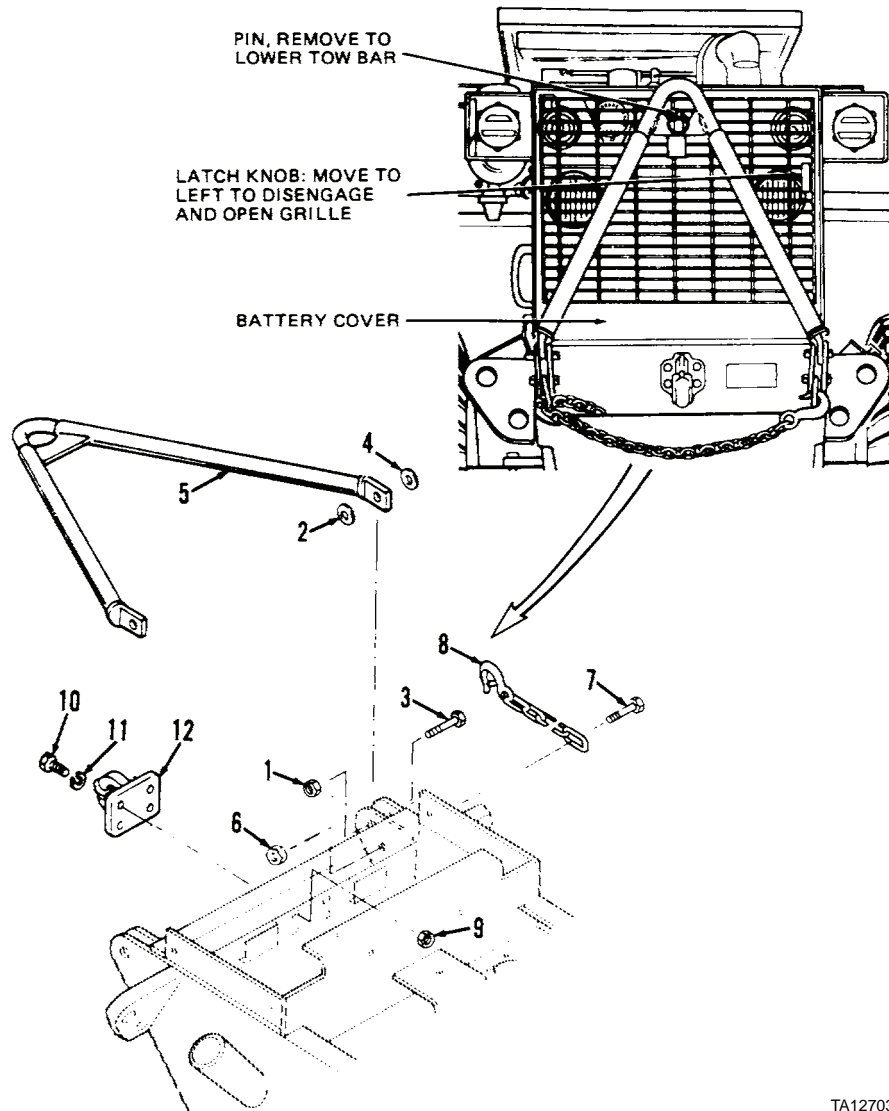

TA127030

**Figure 1. Tow Bar, Chains, and Pintle.****END OF TASK**

**CLEANING****WARNING**

Solvent cleaning compound MIL-PRF-680 Type III is an environmentally compliant and low toxic material. However, it may be irritating to the eyes and skin. Use protective gloves and goggles. Use in well-ventilated areas. Keep away from open flames and other sources of ignition. Failure to do so may result in injury or death to personnel.

Clean all parts with solvent cleaning compound. Dry thoroughly.

**END OF TASK****INSPECTION**

Inspect all parts. Replace if cracked, bent, or distorted.

**END OF TASK****INSTALLATION**

1. At rear of vehicle, install pintle hook (Figure 1, Item 12) with four cap screws (Figure 1, Item 10), new lockwashers (Figure 1, Item 11), and nuts (Figure 1, Item 9).
2. Install battery cover (WP 0132).
3. Swing grille closed until securely latched.
4. Install two chains (Figure 1, Item 8) on rear of vehicle with two capscrews (Figure 1, Item 7) and nuts (Figure 1, Item 6). Stow and hook chains on opposite sides of vehicle.
5. Position tow bar (Figure 1, Item 5) on vehicle and install two capscrews (Figure 1, Item 3), washers (Figure 1, Items 2 and 4), and nuts (Figure 1, Item 1).
6. Raise tow bar (Figure 1, Item 5) to stowed position and secure tow bar by installing pin.

**END OF TASK****END OF WORK PACKAGE**



---

# ORGANIZATIONAL MAINTENANCE INSTRUCTIONS

## GRILLE MAINTENANCE

Removal, Disassembly, Cleaning, Inspection, Assembly, Installation

---

### INITIAL SETUP

#### Maintenance Level

Organizational

#### Tools and Special Tools

Tool kit, general mechanic's (Item 15, WP 0309)

Shop equipment, common no. 1 (Item 2, WP 0309)

#### Materials/Parts

Brush, wire (Item 8, WP 0310)

Cleaning compound, solvent (Item 10, WP 0310)

Diesel fuel, arctic (Item 14, WP 0310)

#### Materials/Parts - Continued

Diesel fuel, DF-2 (Item 15, WP 0310)

Rag, wiping (Item 26, WP 0310)

Lockwasher (5)

#### Equipment Condition

Vehicle parked on level surface

Engine OFF

Parking brake applied

Tow bar lowered to ground and grille opened (WP 0176)

---

**REMOVAL**

1. Remove two nuts (Figure 1, Item 1), lockwashers (Figure 1, Item 2), washers (Figure 1, Item 3), and capscrews (Figure 1, Item 4). Discard lockwashers.
2. Remove grille (Figure 1, Item 5) from vehicle.
3. Remove pivot bracket (Figure 1, Item 6) from grille (Figure 1, Item 5).
4. Remove nut (Figure 1, Item 7), lockwasher (Figure 1, Item 8), washer (Figure 1, Item 9), spacer (Figure 1, Item 10), washer (Figure 1, Item 11), and capscREW (Figure 1, Item 12) from vehicle. Discard lockwasher.

**END OF TASK****DISASSEMBLY**

1. Remove tow bar pin (Figure 1, Item 13) from grille (Figure 1, Item 5). Straighten cotter pin (part of tow bar pin) to remove.
2. Remove two nuts (Figure 1, Item 14) and lockwashers (Figure 1, Item 15) from mounting plate (Figure 1, Item 16). Discard lockwashers.
3. Remove mounting plate (Figure 1, Item 16), capscrews (Figure 1, Items 17 and 18), nut (Figure 1, Item 19), bumper (Figure 1, Item 20), and tow bar bracket (Figure 1, Item 21) from vehicle.
4. Remove latch release knob (Figure 1, Item 22), nut (Figure 1, Item 23), and capscREW (Figure 1, Item 24) from grille latch (Figure 1, Item 28).
5. Remove two nuts (Figure 1, Item 25), washers (Figure 1, Item 26), and capscrews (Figure 1, Item 27) from latch mounting plate (Figure 1, Item 29).
6. Remove grille latch (Figure 1, Item 28) and latch mounting plate (Figure 1, Item 29) from vehicle.

**END OF TASK****CLEANING****WARNING**

DO NOT clean using fuel while smoking or near fire, flames, or sparks. Fuel may ignite, causing damage to machine and injury or death to personnel.

1. Use clean diesel fuel to clean bumper (20). Dry thoroughly.

**WARNING**

Solvent cleaning compound MIL-PRF-680 Type III is an environmentally compliant and low toxic material. However, it may be irritating to the eyes and skin. Use protective gloves and goggles. Use in well-ventilated areas. Keep away from open flames and other sources of ignition. Failure to do so may result in injury or death to personnel.

2. Use solvent cleaning compound to clean all other parts. Dry thoroughly.

## CLEANING - CONTINUED

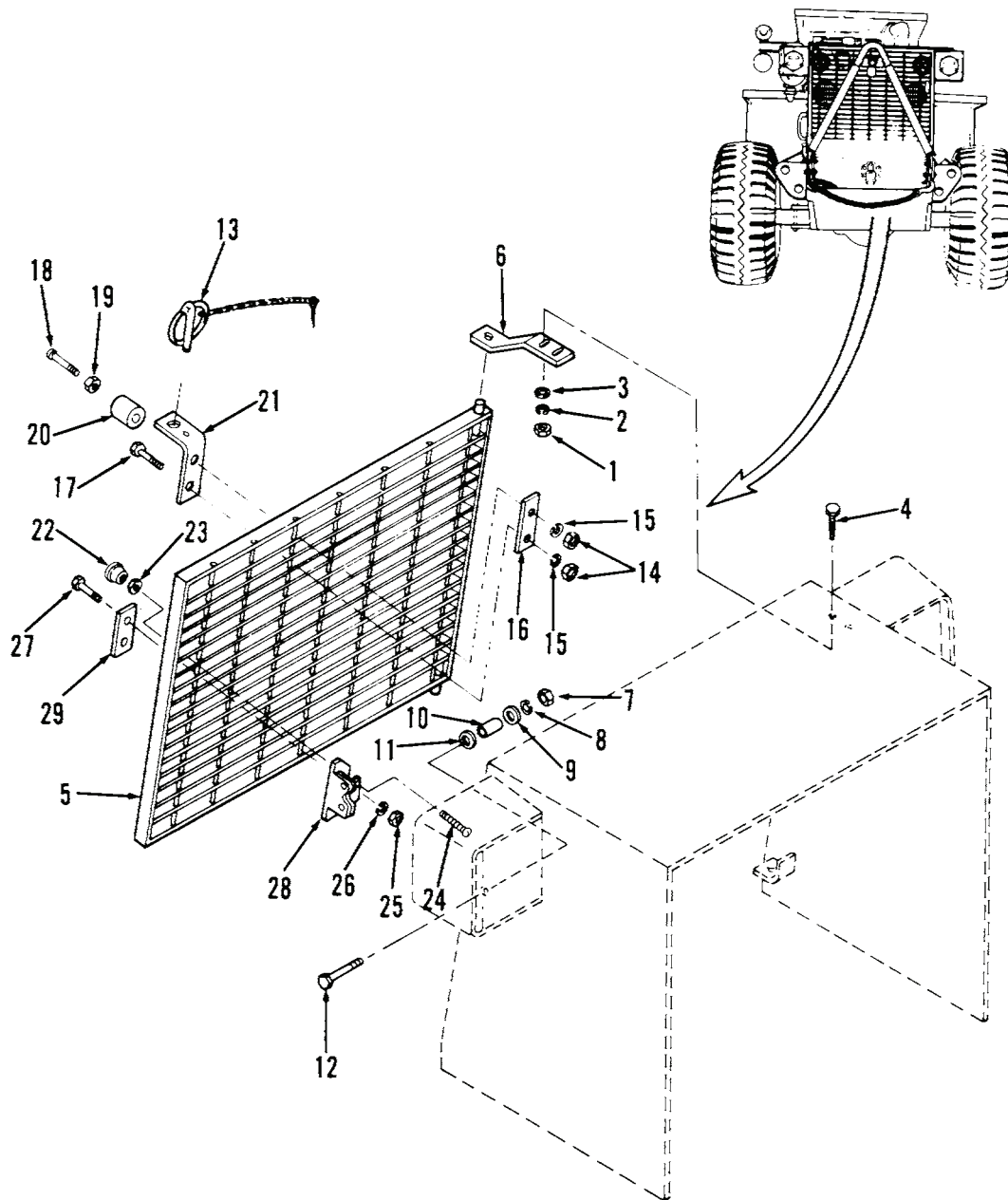

Figure 1. Grille

## END OF TASK

## INSPECTION

1. Inspect grille latch (Figure 1, Item 28). Replace if cracked, damaged, or latch malfunctions.
2. Inspect all other parts. Replace if cracked, damaged, worn, or distorted.

## END OF TASK

---

**ASSEMBLY**

1. Position latch mounting plate (Figure 2, Item 29) on grille (Figure 2, Item 5).
2. Position grille latch (Figure 2, Item 28) on grille (Figure 2, Item 5).
3. Install two capscrews (Figure 2, Item 27), washers (Figure 2, Item 26), and nuts (Figure 2, Item 25) on latch mounting plate (Figure 2, Item 29) and grille latch (Figure 2, Item 28).
4. Install capscrew (Figure 2, Item 24), nut (Figure 2, Item 23), and latch release knob (Figure 2, Item 22) on grille (Figure 2, Item 5).
5. Install nut (Figure 2, Item 19) on capscrew (Figure 2, Item 18).
6. Install bumper (Figure 2, Item 20) on capscrew (Figure 2, Item 18).
7. Position tow bar bracket (Figure 2, Item 21) and mounting plate (Figure 2, Item 16) on grille (Figure 2, Item 5).
8. Install two new lockwashers (Figure 2, Item 15), capscrews (Figure 2, Items 17 and 18), and nuts (Figure 2, Item 14) on tow bar bracket (Figure 2, Item 21) and mounting plate (Figure 2, Item 16) and tighten nuts.
9. Install tow bar pin (Figure 2, Item 13) on grille (Figure 2, Item 5). Bend cotter pin (part of tow bar pin).

**END OF TASK****INSTALLATION**

1. Install capscrew (Figure 2, Item 12), washer (Figure 2, Item 11), spacer (Figure 2, Item 10), washer (Figure 2, Item 9), new lockwasher (Figure 2, Item 8), and nut (Figure 2, Item 7) on vehicle.
2. Position pivot bracket (Figure 2, Item 6) on grille (Figure 2, Item 5).
3. Install two capscrews (Figure 2, Item 4), washers (Figure 2, Item 3), new lockwashers (Figure 2, Item 2), and nuts (Figure 2, Item 1).



INSTALLATION - CONTINUED

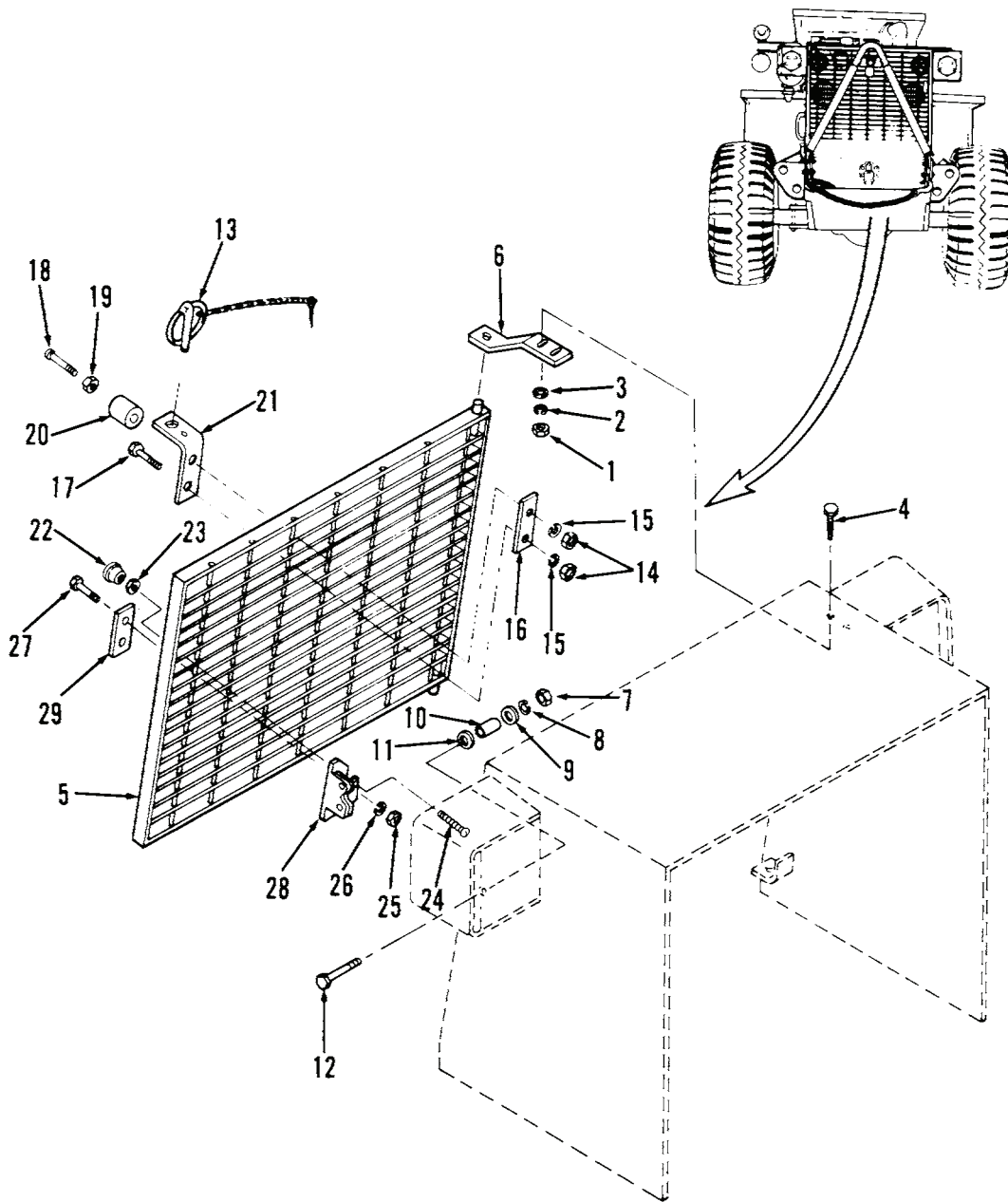

Figure 2. Grille

END OF TASK

END OF WORK PACKAGE



---

# ORGANIZATIONAL MAINTENANCE INSTRUCTIONS

## FENDERS REPLACEMENT

Removal, Cleaning, Inspection, Installation

---

### INITIAL SETUP

#### Maintenance Level

Organizational

#### Tools and Special Tools

Tool kit, general mechanic's (Item 15, WP 0309)

Shop equipment, common no. 1 (Item 2, WP 0309)

#### Materials/Parts

Brush, wire (Item 8, WP 0310)

Cleaning compound, solvent (Item 10, WP 0310)

Rag, wiping (Item 26, WP 0310)

#### Materials/Parts - Continued

Lockwasher (9)

#### References

WP 0110

#### Equipment Condition

Vehicle parked on level surface

Engine OFF

Parking brake applied

Left and right side panels removed (WP 0179)

Stowage box removed (Model 4-390 only) (WP 0189)

---

**REMOVAL**

1. Remove two nuts (Figure 1, Item 1) and lockwashers (Figure 1, Item 2) from capscrews (Figure 1, Item 3). Discard lockwashers.
2. Remove two capscrews (Figure 1, Item 3) and washers (Figure 1, Item 4).
3. Remove nut (Figure 1, Item 5), lockwasher (Figure 1, Item 6), and capscrew (Figure 1, Item 7) from console support bracket. Discard lockwasher.
4. Loosen nut (Figure 1, Item 9) under front fender (Figure 1, Item 8).
5. Pull fender (Figure 1, Item 8) out slightly and capscrew (Figure 1, Item 11), washer (Figure 1, Item 12), lockwasher (Figure 1, Item 10), and nut (Figure 1, Item 9) will disengage from slot in console support bracket.
6. Remove nut (Figure 1, Item 9), lockwasher (Figure 1, Item 10), capscrew (Figure 1, Item 11), and washer (Figure 1, Item 12) from front fender (Figure 1, Item 8). Discard lockwasher.
7. Remove two plugs (Figure 1, Item 13) from rear fender (Figure 1, Item 18).

**NOTE**

Disconnect hourmeter ground wire when removing left rear fender (Model 207 only) (WP 0110).

8. Remove five nuts (Figure 1, Item 14), lockwashers (Figure 1, Item 15), capscrews (Figure 1, Item 16), and nine washers (Figure 1, Item 17). Discard lockwashers.
9. Remove rear fender (Figure 1, Item 18) from vehicle.

**END OF TASK****CLEANING****WARNING**

Solvent cleaning compound MIL-PRF-680 Type III is an environmentally compliant and low toxic material. However, it may be irritating to the eyes and skin. Use protective gloves and goggles. Use in well-ventilated areas. Keep away from open flames and other sources of ignition. Failure to do so may result in injury or death to personnel.

Use solvent cleaning compound to clean all parts. Dry thoroughly. Remove rust using stiff wire brush.

**END OF TASK****INSPECTION**

Inspect all parts. Replace if cracked, damaged, bent, broken, distorted, or threads damaged.

INSPECTION - CONTINUED

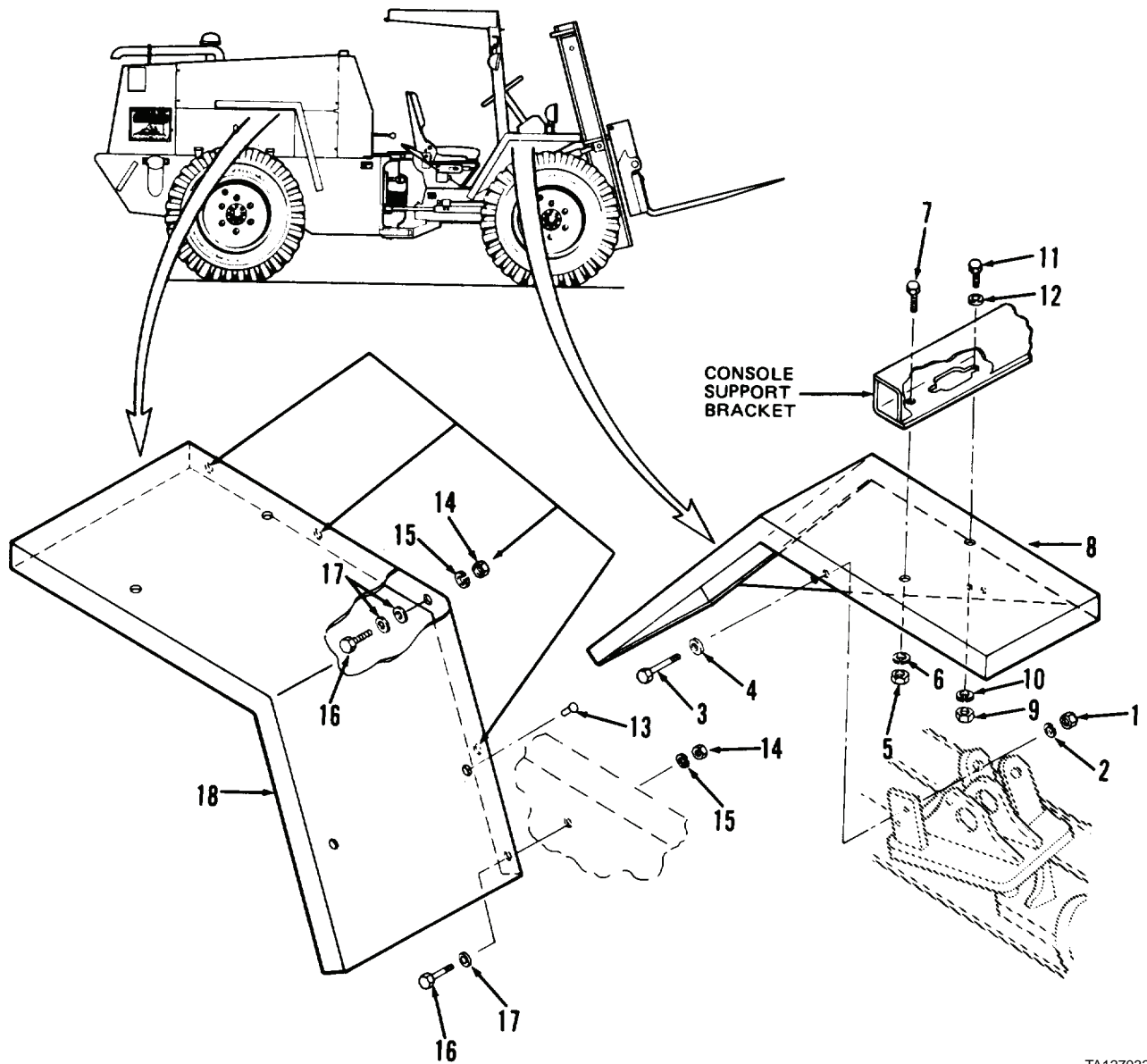

Figure 1. Fenders.

TA127032

END OF TASK

---

**INSTALLATION****NOTE**

Connect hourmeter ground wire when installing left rear fender (Model 207 only) (WP 0110).

1. Position rear fender (Figure 2, Item 18) and install nine washers (Figure 2, Item 17), five capscrews (Figure 2, Item 16), new lockwashers (Figure 2, Item 15), and nuts (Figure 2, Item 14).
2. Install two plugs (Figure 2, Item 13) on rear fender (Figure 2, Item 18).
3. Loosely install washer (Figure 2, Item 12) and capscrew (Figure 2, Item 11) in console support bracket.
4. Position front fender (Figure 2, Item 8). Position assembled capscrew (Figure 2, Item 11) and washer (Figure 2, Item 12) in slot in console support bracket.
5. Install new lockwasher (Figure 2, Item 10) and nut (Figure 2, Item 9) under front fender (Figure 2, Item 8). Tighten nut.
6. Install capscrew (Figure 2, Item 7), new lockwasher (Figure 2, Item 6), and nut (Figure 2, Item 5) on console support bracket and front fender (Figure 2, Item 8).
7. Install two washers (Figure 2, Item 4), capscrews (Figure 2, Item 3), new lockwashers (Figure 2, Item 2), and nuts (Figure 2, Item 1) in front fender (Figure 2, Item 8).
8. Tighten all fasteners in steps 6 and 7.

INSTALLATION - CONTINUED

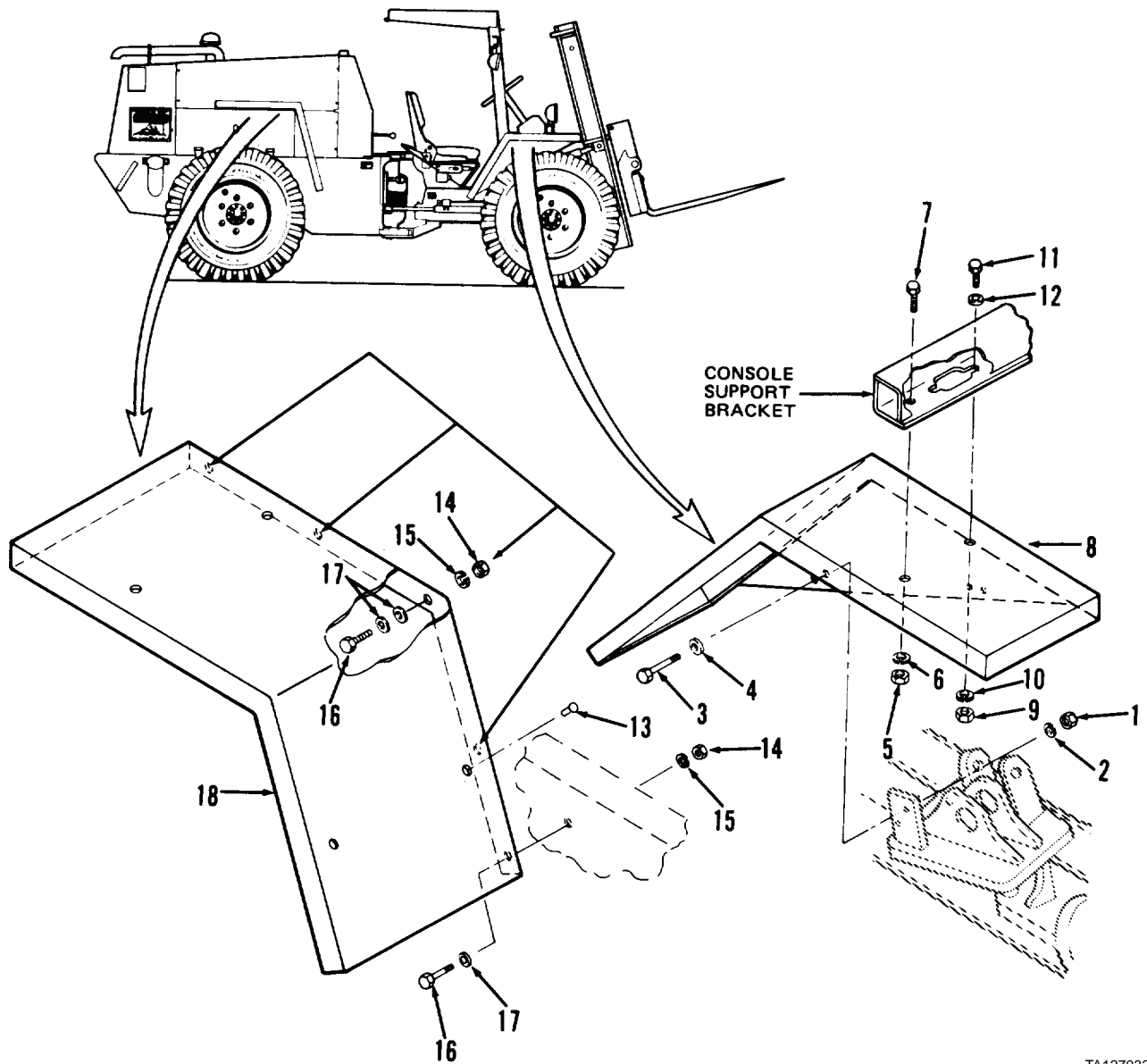

Figure 2. Fenders.

TA127032

END OF TASK

END OF WORK PACKAGE





---

# ORGANIZATIONAL MAINTENANCE INSTRUCTIONS

## SIDE PANELS MAINTENANCE

Removal, Disassembly, Cleaning, Inspection, Assembly, Installation

---

### INITIAL SETUP

**Maintenance Level**

Organizational

**Tools and Special Tools**

Tool kit, general mechanic's (Item 15, WP 0309)

Shop equipment, common no. 1 (Item 2, WP 0309)

**Materials/Parts**

Cleaning compound, solvent (Item 10, WP 0310)

**Materials/Parts - Continued**

Rag, wiping (Item 26, WP 0310)

Cotter pin (2)

Lockwasher (2)

**Equipment Condition**

Vehicle parked on level surface

Engine OFF

Parking brake applied

---

**REMOVAL**

1. Release hood panel hook (Figure 1, Item 13) from hood panel lock brackets (Figure 1, Item 6).
2. Grasp hood panel handle (Figure 1, Item 9), pull outward, and remove side panel (Figure 1, Item 1).

**NOTE**

Perform step 3 only if inspection indicates replacement of hood panel lock brackets is necessary.

3. Remove four nuts (Figure 1, Item 2), washers (Figure 1, Item 3), capscrews (Figure 1, Item 4), lockwashers (Figure 1, Item 5), and two hood panel lock brackets (Figure 1, Item 6) from vehicle. Discard lockwashers.

**END OF TASK****DISASSEMBLY**

1. Remove two capscrews (Figure 1, Item 7) and washers (Figure 1, Item 8) from side panel (Figure 1, Item 1).
2. Remove hood panel handle (Figure 1, Item 9) and two lockwashers (Figure 1, Item 10). Discard lockwashers.
3. Remove two cotter pins (Figure 1, Item 11) from two anchor pins (Figure 1, Item 12). Discard cotter pins.
4. Remove two anchor pins (Figure 1, Item 12) from anchor brackets (Figure 1, Item 17).
5. Remove two hood panel hooks (Figure 1, Item 13) from anchor brackets (Figure 1, Item 17).
6. Remove two nuts (Figure 1, Item 14), screws (Figure 1, Item 15), lockwashers (Figure 1, Item 16), and anchor brackets (Figure 1, Item 17) from side panel (Figure 1, Item 1). Discard lockwashers.

**END OF TASK****CLEANING****WARNING**

Solvent cleaning compound MIL-PRF-680 Type III is an environmentally compliant and low toxic material. However, it may be irritating to the eyes and skin. Use protective gloves and goggles. Use in well-ventilated areas. Keep away from open flames and other sources of ignition. Failure to do so may result in injury or death to personnel.

Use solvent cleaning compound to clean all parts. Dry thoroughly.

**END OF TASK****INSPECTION**

Inspect all parts. Replace if damaged, cracked, bent, distorted, or threads damaged.

## INSPECTION - CONTINUED

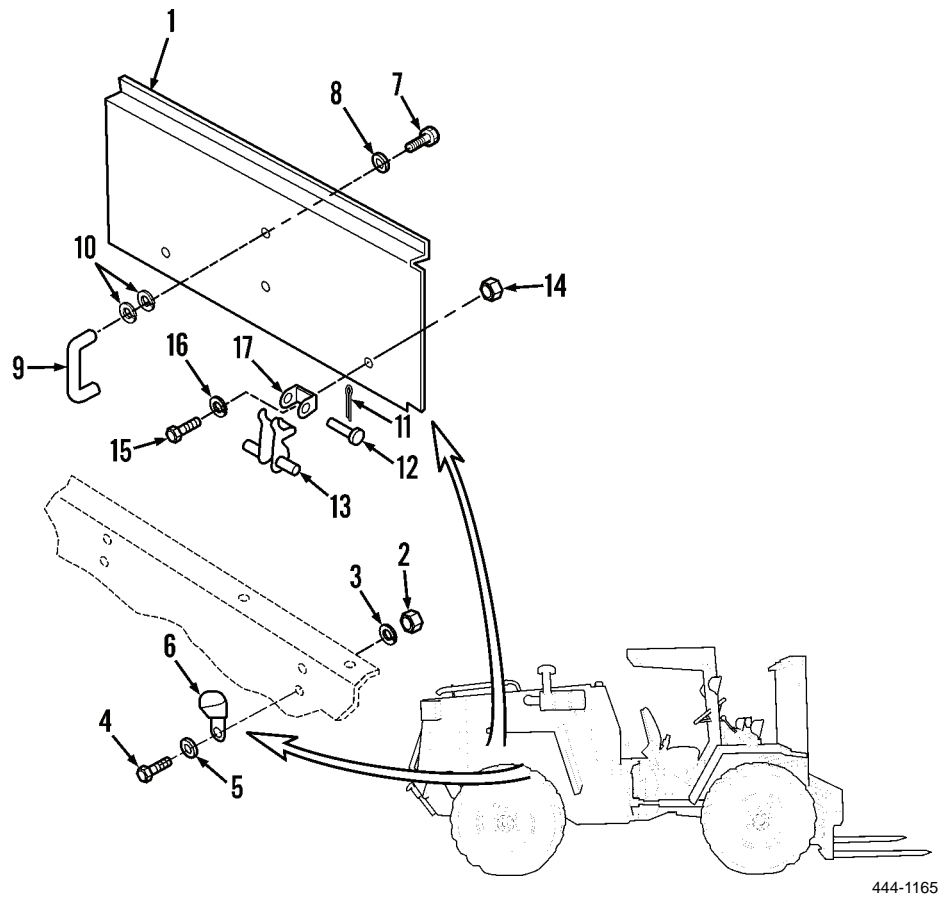

Figure 1. Side Panel.

## END OF TASK

## ASSEMBLY

1. Position two anchor brackets (Figure 1, Item 17) on side panel (Figure 1, Item 1) and install two new lockwashers (Figure 1, Item 16), screws (Figure 1, Item 15), and nuts (Figure 1, Item 14).
2. Position two hood panel hooks (Figure 1, Item 13) on anchor brackets (Figure 1, Item 17).
3. Install two anchor pins (Figure 1, Item 12) on anchor brackets (Figure 1, Item 17).
4. Install two new cotter pins (Figure 1, Item 11) on anchor pins (Figure 1, Item 12).
5. Install hood panel handle (Figure 1, Item 9) on side panel (Figure 1, Item 1) with two new lockwashers (Figure 1, Item 10), washers (Figure 1, Item 8), and capscrews (Figure 1, Item 7). Tighten capscrews.

## END OF TASK

**INSTALLATION**

1. Install two hood panel lock brackets (Figure 2, Item 6) on vehicle with four new lockwashers (Figure 2, Item 5), capscrews (Figure 2, Item 4), washers (Figure 2, Item 3), and nuts (Figure 2, Item 2), if removed.
2. Install side panel (Figure 2, Item 1) on vehicle.
3. Pull down hood panel hook (Figure 2, Item 13) and engage in hood panel lock brackets (Figure 2, Item 6).

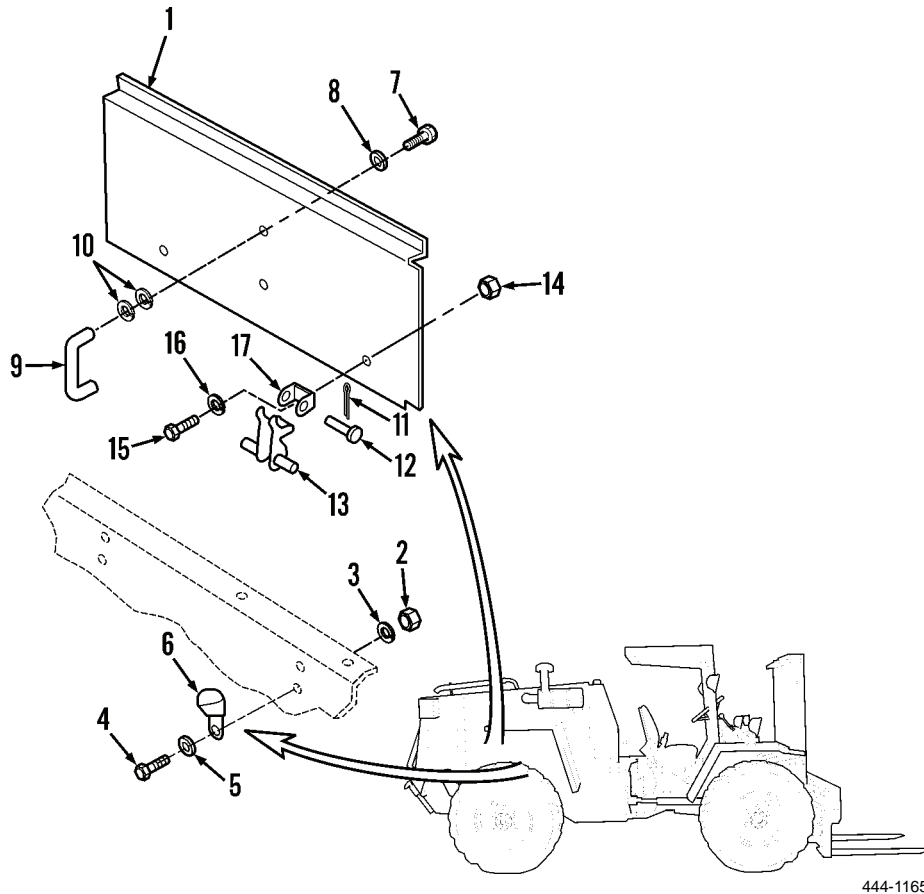

444-1165

**Figure 2. Side Panel.****END OF TASK****END OF WORK PACKAGE**

---

## ORGANIZATIONAL MAINTENANCE INSTRUCTIONS

### TOP HOOD REPLACEMENT (MODEL 207)

#### Removal, Cleaning, Inspection, Installation

---

#### INITIAL SETUP

**Maintenance Level**

Organizational

**Tools and Special Tools**

Tool kit, general mechanic's (Item 15, WP 0309)

Shop equipment, common no. 1 (Item 2, WP 0309)

**Materials/Parts**

Brush, wire (Item 8, WP 0310)

Cleaning compound, solvent (Item 10, WP 0310)

**Materials/Parts - Continued**

Rag, wiping (Item 26, WP 0310)

Lockwasher (18)

**Equipment Condition**

Vehicle parked on level surface

Engine OFF

Parking brake applied

Exhaust pipe removed (WP 0076)

---

**REMOVAL**

1. Remove 18 capscrews (Figure 1, Items 1 and 2), washers (Figure 1, Item 3), and lockwashers (Figure 1, Item 4) from top hood (Figure 1, Item 5). Discard lockwashers.
2. Remove top hood (Figure 1, Item 5) from vehicle.

**END OF TASK****CLEANING****WARNING**

Solvent cleaning compound MIL-PRF-680 Type III is an environmentally compliant and low toxic material. However, it may be irritating to the eyes and skin. Use protective gloves and goggles. Use in well-ventilated areas. Keep away from open flames and other sources of ignition. Failure to do so may result in injury or death to personnel.

Use solvent cleaning compound to clean all parts. Dry thoroughly. Remove any rust with stiff wire brush.

**END OF TASK****INSPECTION**

Inspect all parts. Replace if cracked, damaged, bent, distorted, or threads damaged.

**END OF TASK****INSTALLATION**

1. Position top hood (Figure 1, Item 5) on vehicle.
2. Install 18 new lockwashers (Figure 1, Item 4), washers (Figure 1, Item 3), and capscrews (Figure 1, Items 2 and 1) on top hood (Figure 1, Item 5).
3. Install exhaust pipe (WP 0076).

INSTALLATION - CONTINUED

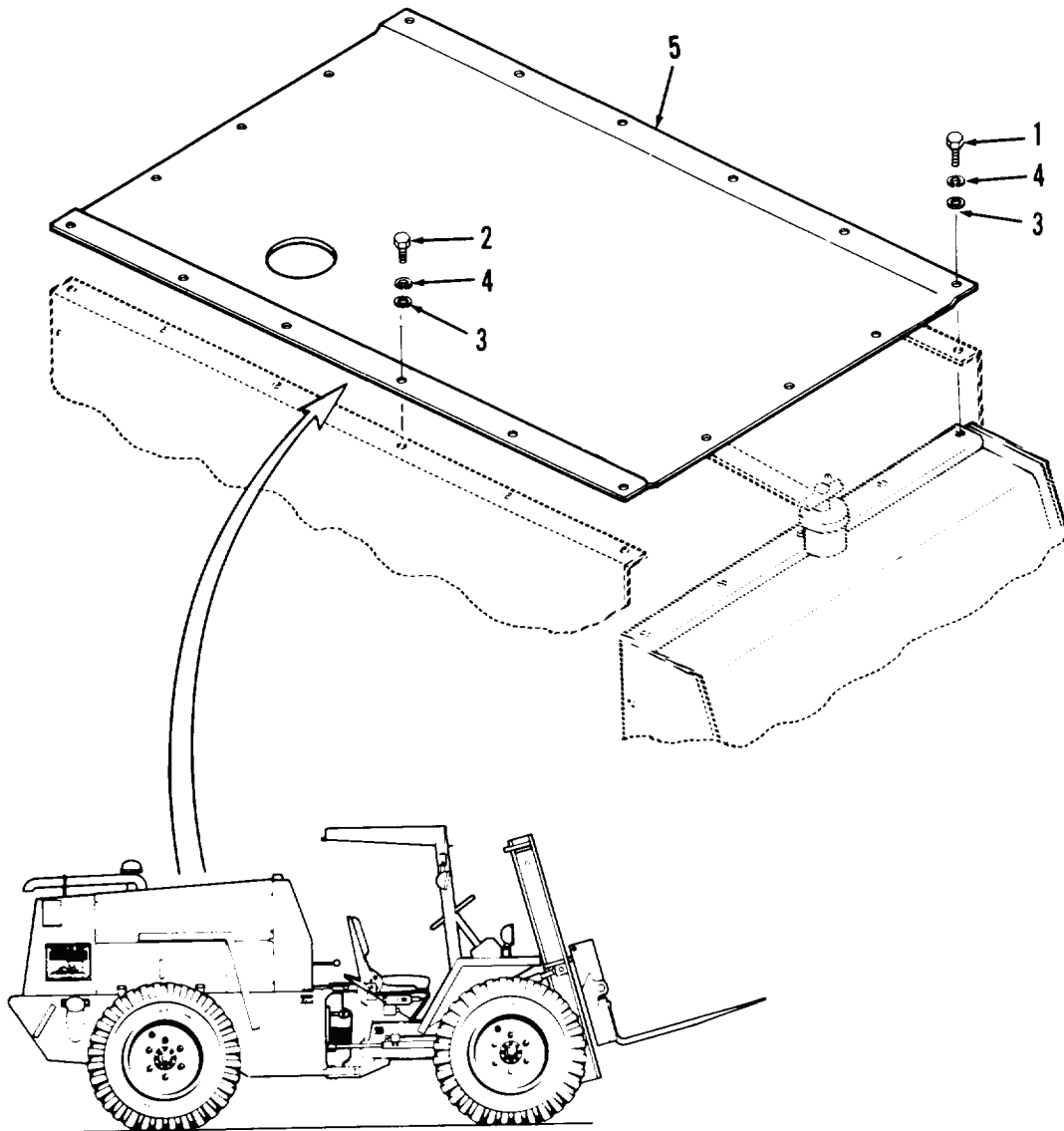

Figure 1. Top Hood.

TA127034

END OF TASK

END OF WORK PACKAGE





---

## ORGANIZATIONAL MAINTENANCE INSTRUCTIONS

### TOP HOOD REPLACEMENT (MODEL 4-390)

Removal, Cleaning, Inspection, Installation

---

#### INITIAL SETUP

##### Maintenance Level

Organizational

##### Tools and Special Tools

Tool kit, general mechanic's (Item 15, WP 0309)

Shop equipment, common no. 1 (Item 2, WP 0309)

##### Materials/Parts

Brush, wire (Item 8, WP 0310)

##### Materials/Parts - Continued

Cleaning compound, solvent (Item 10, WP 0310)

Rag, wiping (Item 26, WP 0310)

Lockwasher (18)

##### Equipment Condition

Engine OFF

Exhaust pipe removed (WP 0077)

---

**REMOVAL**

1. At engine compartment, remove 18 capscrews (Figure 1, Items 1 and 2), washers (Figure 1, Item 3), and lockwashers (Figure 1, Item 4). Discard lockwashers.
2. Remove top hood (Figure 1, Item 5) from vehicle.

**END OF TASK****CLEANING****WARNING**

Solvent cleaning compound MIL-PRF-680 Type III is an environmentally compliant and low toxic material. However, it may be irritating to the eyes and skin. Use protective gloves and goggles. Use in well-ventilated areas. Keep away from open flames and other sources of ignition. Failure to do so may result in injury or death to personnel.

1. Remove any rust with wire brush.
2. Clean all parts with solvent cleaning compound. Dry with clean rags.

**END OF TASK****INSPECTION**

Inspect all parts. Replace if cracked, damaged, bent, distorted, or threads are damaged.

**END OF TASK****INSTALLATION**

1. Position top hood (Figure 1, Item 5) on top of engine compartment.
2. Install 18 new lockwashers (Figure 1, Item 4), washers (Figure 1, Item 3), and capscrews (Figure 1, Items 2 and 1).
3. Install exhaust pipe (WP 0077).

INSTALLATION - CONTINUED

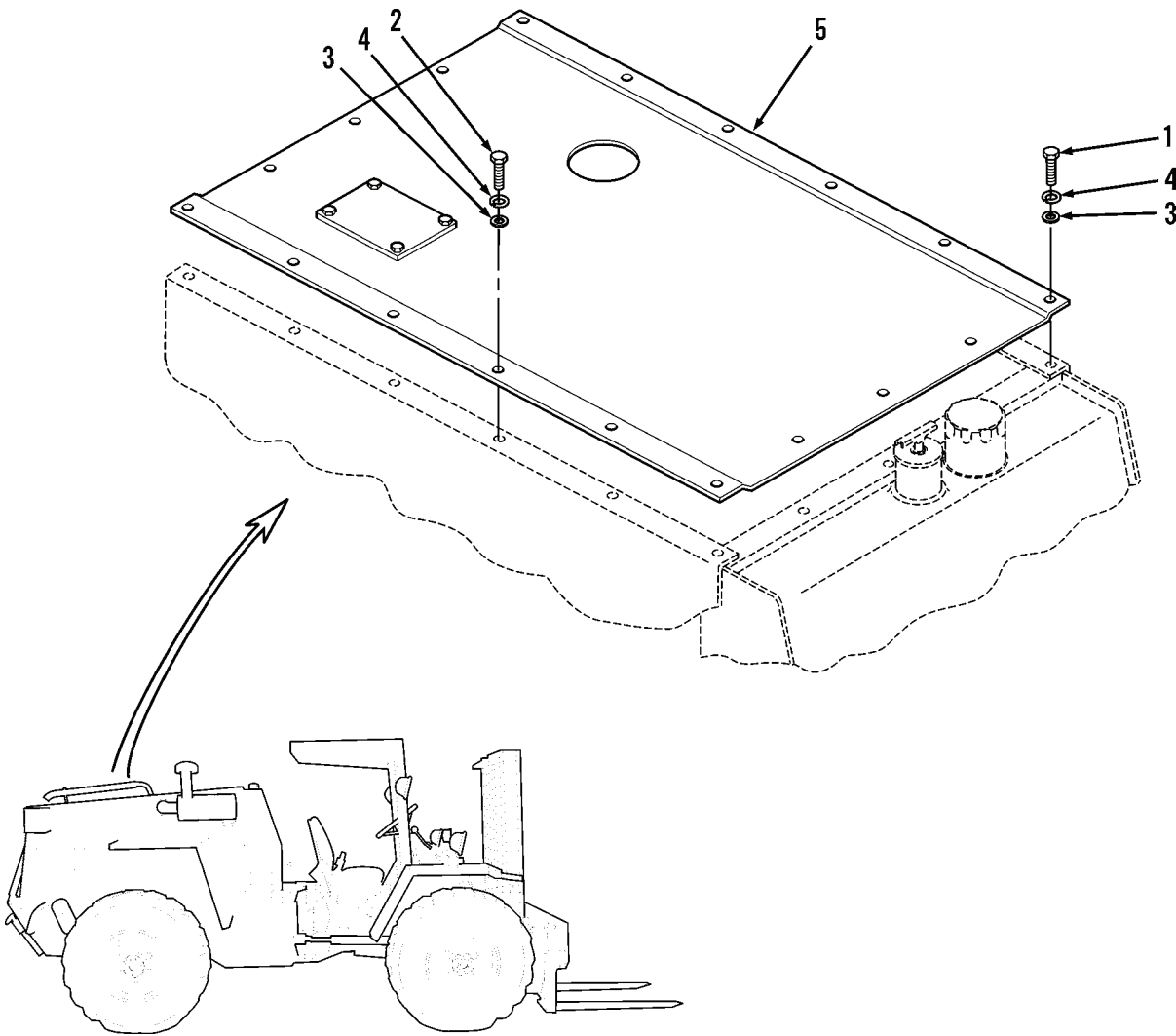

444-0141

Figure 1. Top Hood.

END OF TASK

END OF WORK PACKAGE



---

## ORGANIZATIONAL MAINTENANCE INSTRUCTIONS

### HOOD PANELS AND HOOD SUPPORT PLATES REPLACEMENT (MODEL 207)

#### Removal, Cleaning, Inspection, Installation

---

#### INITIAL SETUP

**Maintenance Level**

Organizational

**Tools and Special Tools**

Tool kit, general mechanic's (Item 15, WP 0309)

Shop equipment, common no. 1 (Item 2, WP 0309)

**Materials/Parts**

Brush, wire (Item 8, WP 0310)

Cleaning compound, solvent (Item 10, WP 0310)

Rag, wiping (Item 26, WP 0310)

Lockwasher (9)

**References**

WP 0180

**Equipment Condition**

Vehicle parked on level surface

Engine OFF

Parking brake applied

Air cleaner removed (left hood panel removal only) (WP 0061)

Slave receptacle removed (WP 0109)

Hourmeter removed (WP 0110)

Rear fenders removed (WP 0178)

---

**REMOVAL**

1. Remove two nuts (Figure 1, Item 1), four capscrews (Figure 1, Items 2 and 3), lockwashers (Figure 1, Item 4), and washers (Figure 1, Item 5) from hood panel (Figure 1, Item 6 or 7). Discard lockwashers.
2. Remove hood panel (Figure 1, Item 6 or 7) from vehicle.

**NOTE**

If top hood is not removed (WP 0180) you must remove six capscrews, washers, and lockwashers.

3. Remove three nuts (Figure 1, Item 8), lockwashers (Figure 1, Item 9), washers (Figure 1, Item 10), and capscrews (Figure 1, Item 11) from hood support plate (Figure 1, Item 15 or 16). Discard lockwashers.
4. Remove two capscrews (Figure 1, Item 12), lockwashers (Figure 1, Item 13), and washers (Figure 1, Item 14) from hood support plate (Figure 1, Item 15 or 16). Discard lockwashers.
5. Disconnect ground cable and remove ground cable washer if left hood support plate (Figure 1, Item 15) is being removed.
6. Remove hood support plate (Figure 1, Item 15 or 16) from vehicle.

**END OF TASK****CLEANING****WARNING**

Solvent cleaning compound MIL-PRF-680 Type III is an environmentally compliant and low toxic material. However, it may be irritating to the eyes and skin. Use protective gloves and goggles. Use in well-ventilated areas. Keep away from open flames and other sources of ignition. Failure to do so may result in injury or death to personnel.

Use solvent cleaning compound to clean all parts. Dry thoroughly. Remove rust with stiff wire brush.

**END OF TASK****INSPECTION**

Inspect all parts. Replace if cracked, damaged, broken, bent, distorted, or threads damaged.

**END OF TASK****INSTALLATION**

1. Position hood support plate (Figure 1, Item 15 or 16) and install two washers (Figure 1, Item 14), new lockwashers (Figure 1, Item 13), and capscrews (Figure 1, Item 12). Tighten capscrews.
2. Connect ground cable and ground cable washer only if left hood support plate (Figure 1, Item 15) is being installed.

**NOTE**

Be sure clamp securing cold start tube and air cleaner indicator tube is installed.

3. Install three capscrews (Figure 1, Item 11), washers (Figure 1, Item 10), new lockwashers (Figure 1, Item 9), and nuts (Figure 1, Item 8) on hood support plate (Figure 1, Item 15 or 16) and tighten nuts.
4. Position hood panel (Figure 1, Item 6 or 7) on vehicle and install four washers (Figure 1, Item 5), new lockwashers (Figure 1, Item 4), capscrews (Figure 1, Items 3 and 2), and two nuts (Figure 1, Item 1). Tighten nuts.

INSTALLATION - CONTINUED

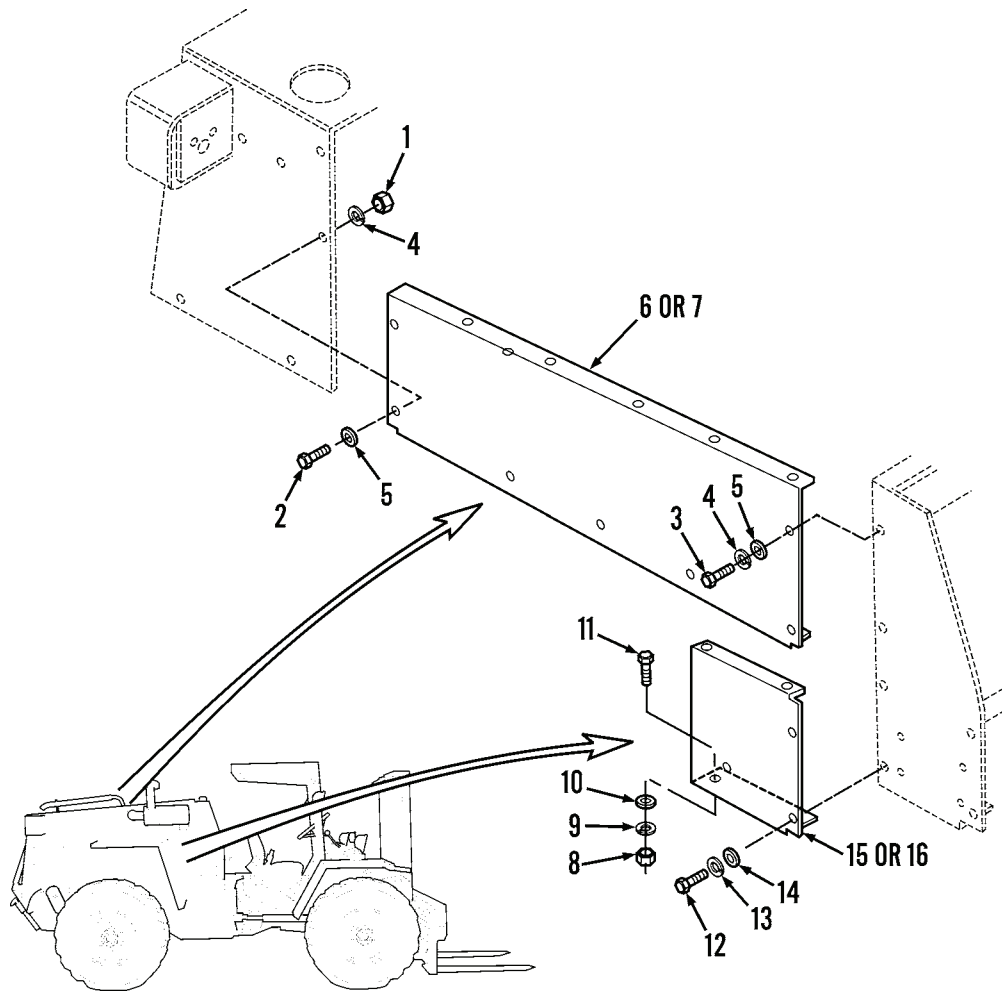

444-1167

Figure 1. Hood Panel and Hood Support Plate.

END OF TASK

END OF WORK PACKAGE





---

## ORGANIZATIONAL MAINTENANCE INSTRUCTIONS

### HOOD PANELS AND HOOD SUPPORT PLATES REPLACEMENT (MODEL 4-390)

#### Removal, Cleaning, Inspection, Installation

---

#### INITIAL SETUP

**Maintenance Level**

Organizational

**References**

WP 0181

**Tools and Special Tools**

Tool kit, general mechanic's (Item 15, WP 0309)

Shop equipment, common no. 1 (Item 2, WP 0309)

**Equipment Condition**

Engine OFF

Air cleaner removed (right hood panel removal only) (WP 0062)

Slave receptacle removed (left hood support plate removal only) (WP 0109)

Hourmeter removed (left hood support plate removal only) (WP 0110)

**Materials/Parts**

Brush, wire (Item 8, WP 0310)

Cleaning compound, solvent (Item 10, WP 0310)

Rag, wiping (Item 26, WP 0310)

Lockwasher (14)

Rear fenders removed (WP 0178)

---

**REMOVAL**

1. At upper-left or upper-right side of engine compartment, remove two nuts (Figure 1, Item 1), four capscrews (Figure 1, Items 2 and 3), lockwashers (Figure 1, Item 4), and washers (Figure 1, Item 5). Discard lockwashers.

**NOTE**

If top hood has not been removed (WP 0181), you must remove six additional capscrews, washers, and lockwashers.

2. Remove hood panel (Figure 1, Item 6 or 7) from vehicle.
3. At left or right side of engine compartment, remove two nuts (Figure 1, Item 8), lockwashers (Figure 1, Item 9), washers (Figure 1, Item 10), and capscrews (Figure 1, Item 11) Discard lockwashers.
4. Remove two capscrews (Figure 1, Item 12), lockwashers (Figure 1, Item 13), and washers (Figure 1, Item 14). Discard lockwashers.
5. Remove hood support plate (Figure 1, Item 15 or 16) from vehicle.
6. Remove grommet (Figure 1, Item 17) from right hood panel (Figure 1, Item 6).

**END OF TASK****CLEANING****WARNING**

Solvent cleaning compound MIL-PRF-680 Type III is an environmentally compliant and low toxic material. However, it may be irritating to the eyes and skin. Use protective gloves and goggles. Use in well-ventilated areas. Keep away from open flames and other sources of ignition. Failure to do so may result in injury or death to personnel.

Remove rust with stiff wire brush and clean all parts with solvent cleaning compound. Dry with clean rags.

**END OF TASK****INSPECTION**

Inspect all parts. Replace if cracked, damaged, broken, bent, distorted, or threads are damaged.

**END OF TASK**

**INSTALLATION**

1. Install grommet (Figure 1, Item 17) on right hood panel (Figure 1, Item 6).
2. Position hood support plate (Figure 1, Item 15 or 16) on vehicle.
3. Install two washers (Figure 1, Item 14), new lockwashers (Figure 1, Item 13), and capscrews (Figure 1, Item 12).
4. Install two capscrews (Figure 1, Item 11), washers (Figure 1, Item 10), new lockwashers (Figure 1, Item 9), and nuts (Figure 1, Item 8).
5. At upper-left or upper-right side of engine compartment, position hood panel (Figure 1, Item 6 or 7) on vehicle.
6. Install four washers (Figure 1, Item 5), new lockwashers (Figure 1, Item 4), four capscrews (Figure 1, Items 3 and 2), and nuts (Figure 1, Item 1).

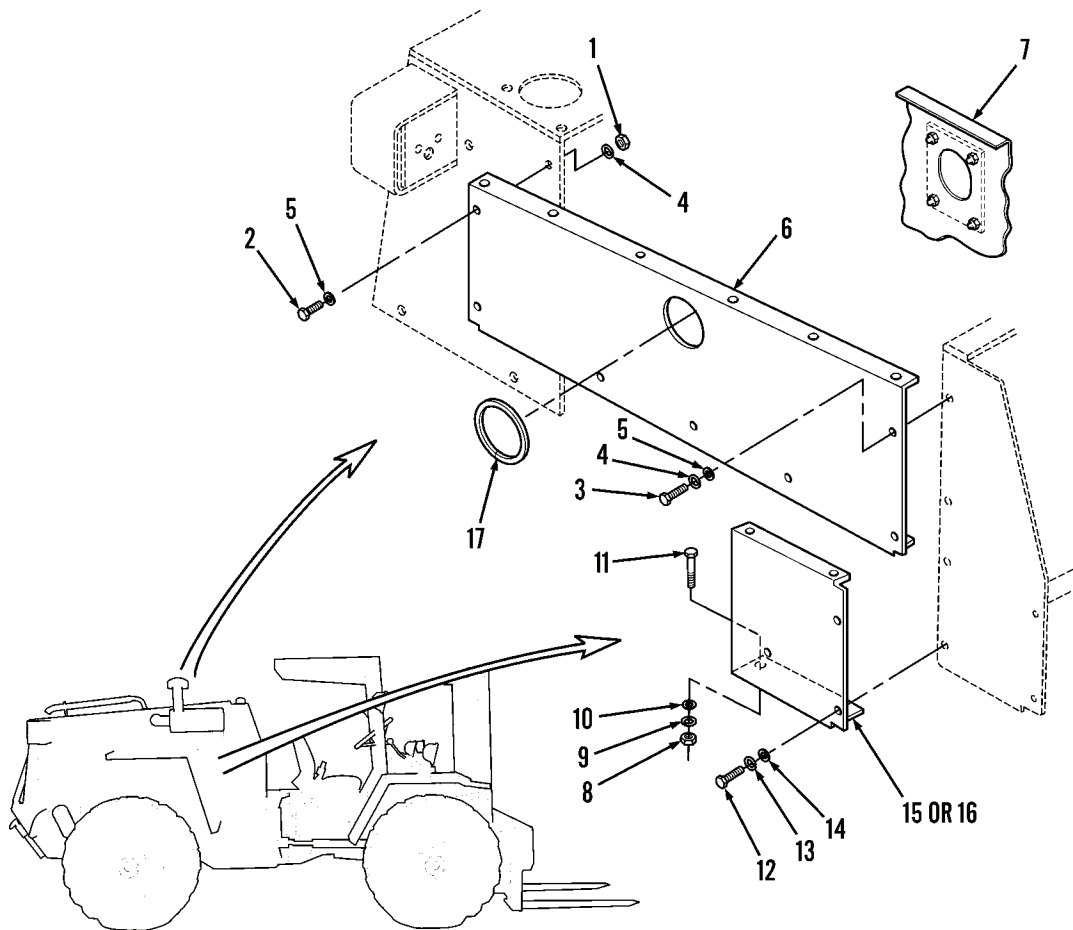

444-0143

**Figure 1. Hood Panel and Hood Support Plate.****END OF TASK****END OF WORK PACKAGE**



---

## ORGANIZATIONAL MAINTENANCE INSTRUCTIONS

### FRONT COVER PANEL REPLACEMENT

Removal, Cleaning, Inspection, Installation

---

#### INITIAL SETUP

##### Maintenance Level

Organizational

##### Tools and Special Tools

Tool kit, general mechanic's (Item 15, WP 0309)

Shop equipment, common no. 1 (Item 2, WP 0309)

##### Materials/Parts

Brush, wire (Item 8, WP 0310)

Cap set, protective (Item 9, WP 0310)

##### Materials/Parts - Continued

Cleaning compound, solvent (Item 10, WP 0310)

Rag, wiping (Item 26, WP 0310)

Lockwasher (8)

##### Equipment Condition

Vehicle parked on level surface

Engine OFF

Parking brake applied

---

**REMOVAL**

1. Remove axle disconnect lever knob.
2. Remove six capscrews (Figure 1, Item 1), washers (Figure 1, Item 2), and lockwashers (Figure 1, Item 3) from front cover panel (Figure 1, Item 5). Discard lockwashers.

**CAUTION**

To prevent entry of foreign material into transmission which could cause damage, plug tube and hose after removal of dipstick and front cover plate, respectively.

3. Remove dipstick from dipstick tube.
4. Loosen clamp (Figure 1, Item 4) on dipstick assembly hose.
5. Remove front cover panel (Figure 1, Item 5) from vehicle.
6. Remove two nuts (Figure 1, Item 6), lockwashers (Figure 1, Item 7), and capscrews (Figure 1, Item 8) from flange-mounted bearing (Figure 1, Item 9) and front cover panel (Figure 1, Item 5). Discard lockwashers.
7. Remove flange-mounted bearing (Figure 1, Item 9) from front cover panel (Figure 1, Item 5).

**END OF TASK****CLEANING****WARNING**

Solvent cleaning compound MIL-PRF-680 Type III is an environmentally compliant and low toxic material. However, it may be irritating to the eyes and skin. Use protective gloves and goggles. Use in well-ventilated areas. Keep away from open flames and other sources of ignition. Failure to do so may result in injury or death to personnel.

Use solvent cleaning compound to clean all parts. Dry thoroughly. Remove rust using stiff wire brush.

**END OF TASK****INSPECTION**

Inspect all parts. Replace if cracked, damaged, broken, bent, distorted, missing, or damaged threads.

INSPECTION - CONTINUED

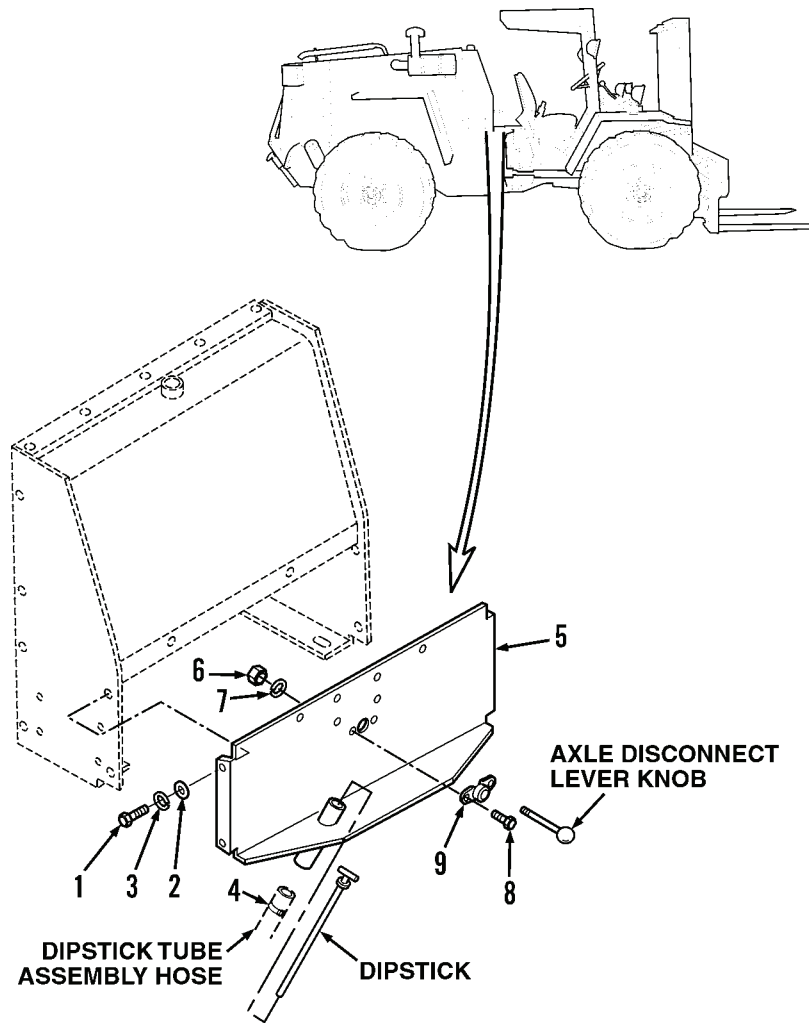

444-1168

Figure 1. Front Cover Panel.

END OF TASK

---

**INSTALLATION**

1. Position flange-mounted bearing (Figure 2, Item 9) on front cover panel (Figure 2, Item 5).
2. Install two capscrews (Figure 2, Item 8), new lockwashers (Figure 2, Item 7), and nuts (Figure 2, Item 6) in flange-mounted bearing (Figure 2, Item 9) and front cover panel (Figure 2, Item 5). Tighten nuts.
3. Position front cover panel (Figure 2, Item 5) on vehicle.
4. Connect dipstick tube assembly hose to front cover panel (Figure 2, Item 5) tube and tighten clamp (Figure 2, Item 4).
5. Install six washers (Figure 2, Item 3), new lockwashers (Figure 2, Item 2), and capscrews (Figure 2, Item 1) in front cover panel (Figure 2, Item 5).
6. Install dipstick in dipstick tube.
7. Install axle disconnect lever knob on vehicle.



INSTALLATION - CONTINUED

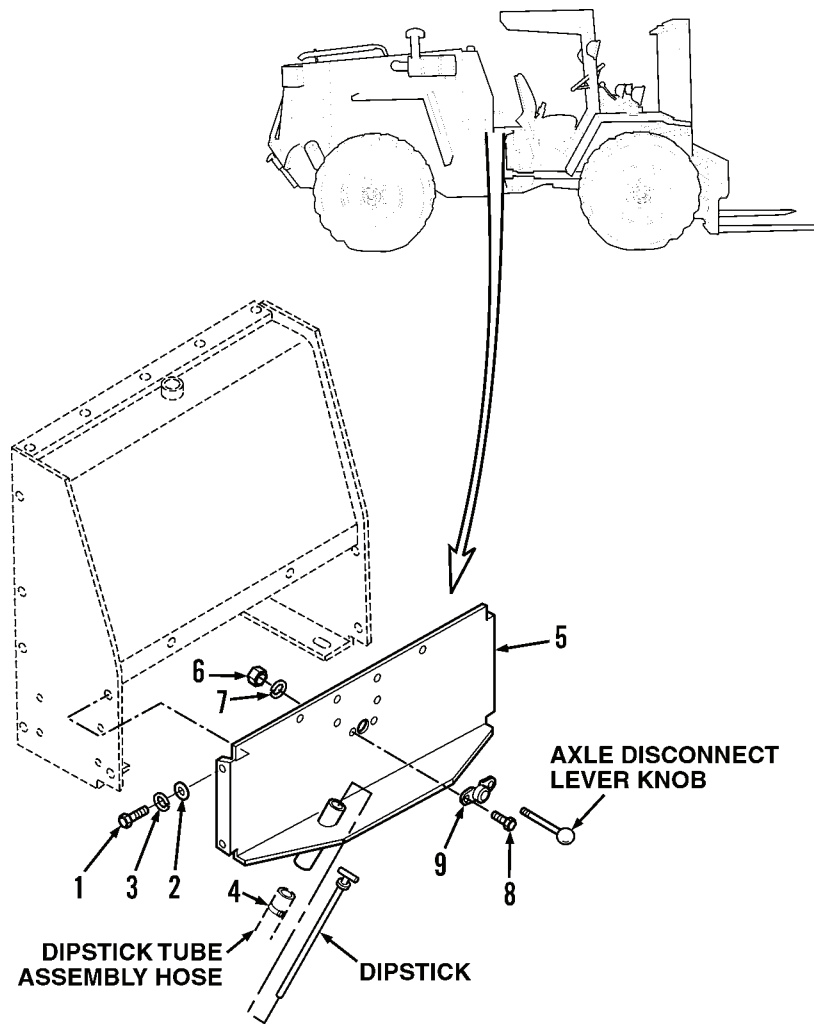

444-1168

Figure 2. Front Cover Panel.

END OF TASK

END OF WORK PACKAGE



---

## ORGANIZATIONAL MAINTENANCE INSTRUCTIONS

### OPERATOR'S SEAT MAINTENANCE (MODEL 207)

Removal, Disassembly, Cleaning, Inspection, Assembly, Installation

---

#### INITIAL SETUP

##### Maintenance Level

Organizational

##### Tools and Special Tools

Tool kit, general mechanic's (Item 15, WP 0309)

Shop equipment, common no. 1 (Item 2, WP 0309)

##### Materials/Parts

Cleaning compound, solvent (Item 10, WP 0310)

##### Materials/Parts - Continued

Detergent, liquid (Item 13, WP 0310)

Rag, wiping (Item 26, WP 0310)

Lockwasher (8)

Water

##### Equipment Condition

Vehicle parked on level surface

Engine OFF

Parking brake applied

---

**REMOVAL**

1. Remove two nuts (Figure 1, Item 1), lockwashers (Figure 1, Item 2), and capscrews (Figure 1, Item 3) from seat belt (Figure 1, Item 4) and mounting bracket. Discard lockwashers.
2. Remove seat belt (Figure 1, Item 4) from vehicle.
3. Remove four nuts (Figure 1, Item 5) and lockwashers (Figure 1, Item 6) from seat adjusters (Figure 1, Items 9 and 10). Discard lockwashers.
4. Remove operator's seat assembly (Figure 1, Item 7) from vehicle.

**END OF TASK****DISASSEMBLY**

1. Remove four screws (Figure 1, Item 8) and seat adjusters (Figure 1, Items 9 and 10).
2. Remove eight screws (Figure 1, Item 11) from rails (Figure 1, Items 17 and 18).
3. Remove back rest (Figure 1, Item 12) from rails (Figure 1, Items 17 and 18).
4. Remove cushion (Figure 1, Item 13) from rails (Figure 1, Items 17 and 18).
5. Remove two nuts (Figure 1, Items 14), lockwashers (Figure 1, Item 15), and screws (Figure 1, Item 16) from rails (Figure 1, Items 17 and 18). Discard lockwashers.

**END OF TASK****CLEANING**

1. Use mild detergent and water to clean back rest (Figure 1, Item 12), cushion (Figure 1, Item 13), and seat belt (Figure 1, Item 4). Dry thoroughly.

**WARNING**

Solvent cleaning compound MIL-PRF-680 Type III is an environmentally compliant and low toxic material. However, it may be irritating to the eyes and skin. Use protective gloves and goggles. Use in well-ventilated areas. Keep away from open flames and other sources of ignition. Failure to do so may result in injury or death to personnel.

2. Use solvent cleaning compound to clean all other parts. Dry thoroughly.

**END OF TASK****INSPECTION**

1. Inspect back rest (Figure 1, Item 12) and cushion (Figure 1, Item 13). Replace if damaged, worn, cracked, or slit.
2. Inspect seat belt (Figure 1, Item 4). Replace if damaged, worn, slit, or buckles damaged.
3. Inspect seat adjusters (Figure 1, Items 10 and 9). Replace if damaged, worn, cracked, distorted, or does not slide freely.
4. Inspect all other parts. Replace if damaged, worn, cracked, distorted, or threads damaged.

INSPECTION - CONTINUED

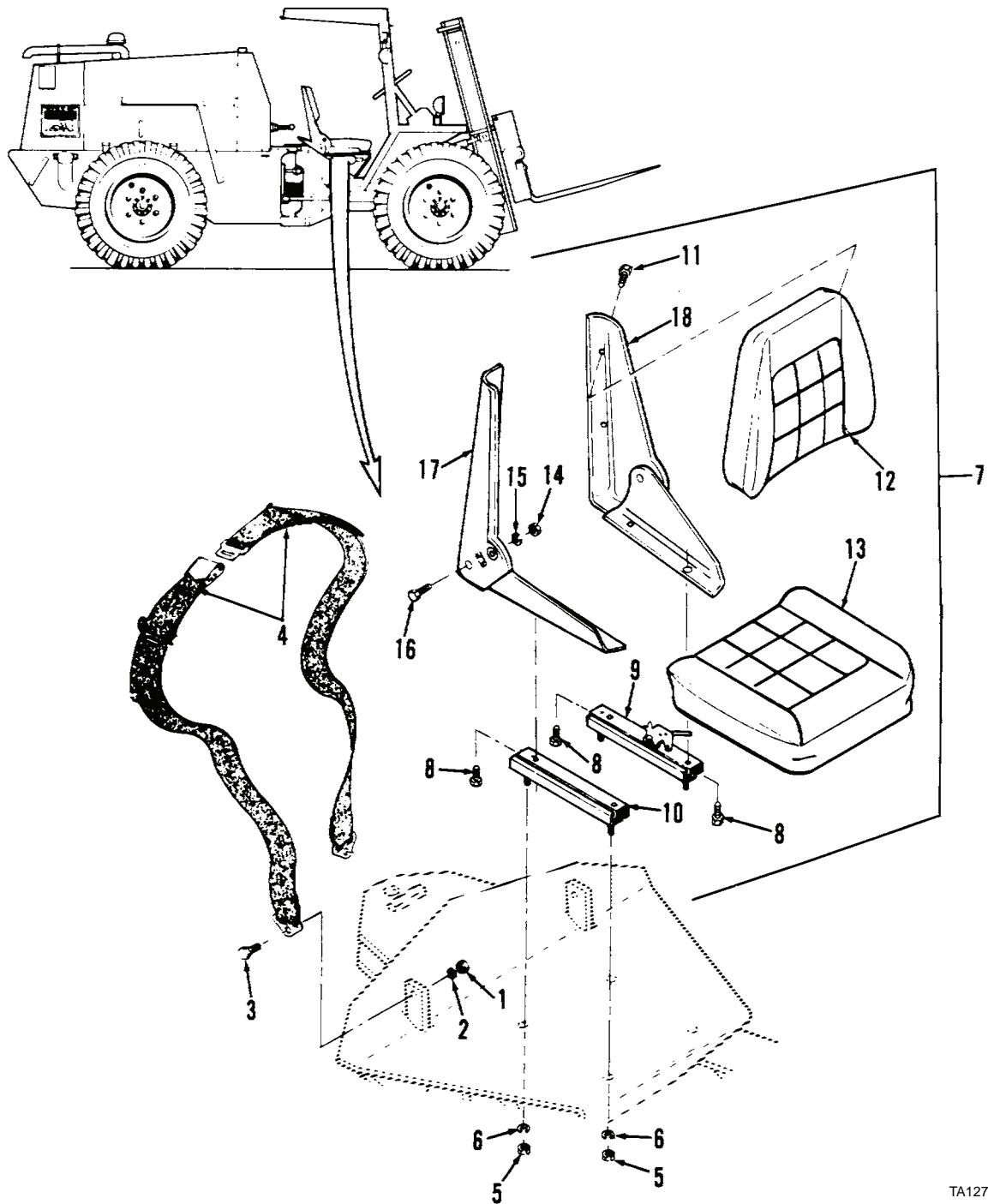

Figure 1. Operator's Seat.

TA127037

END OF TASK

**ASSEMBLY**

1. Install two screws (Figure 2, Item 16), new lockwashers (Figure 2, Item 15), and nuts (Figure 2, Item 14) on rails (Figure 2, Items 17 and 18).
2. Position cushion (Figure 2, Item 13) and back rest (Figure 2, Item 12) on rails (Figure 2, Items 17 and 18).
3. Install eight screws (Figure 2, Item 11) in rails (Figure 2, Items 17 and 18).
4. Position seat adjusters (Figure 2, Items 10 and 9) and extend adjusters. Line up screw holes with rail holes.
5. Install four screws (Figure 2, Item 8) on seat adjusters (Figure 2, Items 10 and 9).

**END OF TASK****INSTALLATION**

1. Position seat assembly (Figure 2, Item 7) and install four new lockwashers (Figure 2, Item 6) and nuts (Figure 2, Item 5).
2. Position seat belt (Figure 2, Item 4) and install two capscrews (Figure 2, Item 3), new lockwashers (Figure 2, Item 2), and nuts (Figure 2, Item 1).

INSTALLATION - CONTINUED

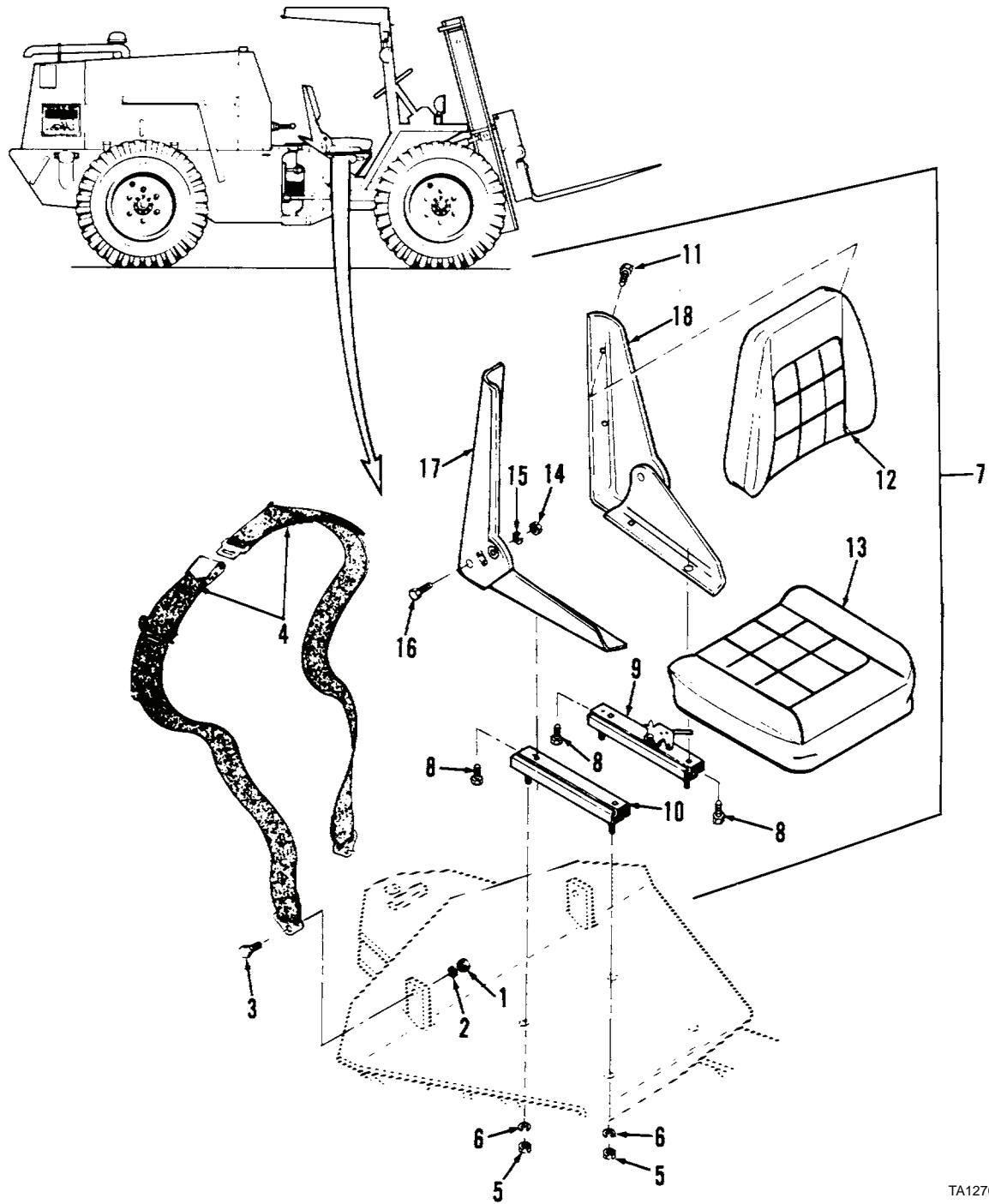

Figure 2. Operator's Seat.

TA127037

END OF TASK

END OF WORK PACKAGE





---

## ORGANIZATIONAL MAINTENANCE INSTRUCTIONS

### OPERATOR'S SEAT MAINTENANCE (MODEL 4-390)

Removal, Disassembly, Cleaning, Inspection, Assembly, Installation

---

#### INITIAL SETUP

**Maintenance Level**

Organizational

**Tools and Special Tools**

Tool kit, general mechanic's (Item 15, WP 0309)

Shop equipment, common no. 1 (Item 2, WP 0309)

**Materials/Parts**

Cleaning compound, solvent (Item 10, WP 0310)

**Materials/Parts - Continued**

Detergent, liquid (Item 13, WP 0310)

Rag, wiping (Item 26, WP 0310)

Locknut (2)

Lockwasher (4)

Water

**Equipment Condition**

Engine OFF

---

**REMOVAL**

1. In operator's compartment, raise seat adjustment bar (Figure 1, Item 5) and adjust position of seat adjusters (Figure 1, Items 6 and 7) for access to all four socket head capscrews (Figure 1, Item 3).
2. Remove four nuts (Figure 1, Item 1), lockwashers (Figure 1, Item 2), socket head capscrews (Figure 1, Item 3), and operator's seat assembly (Figure 1, Item 4) from vehicle. Discard lockwashers.

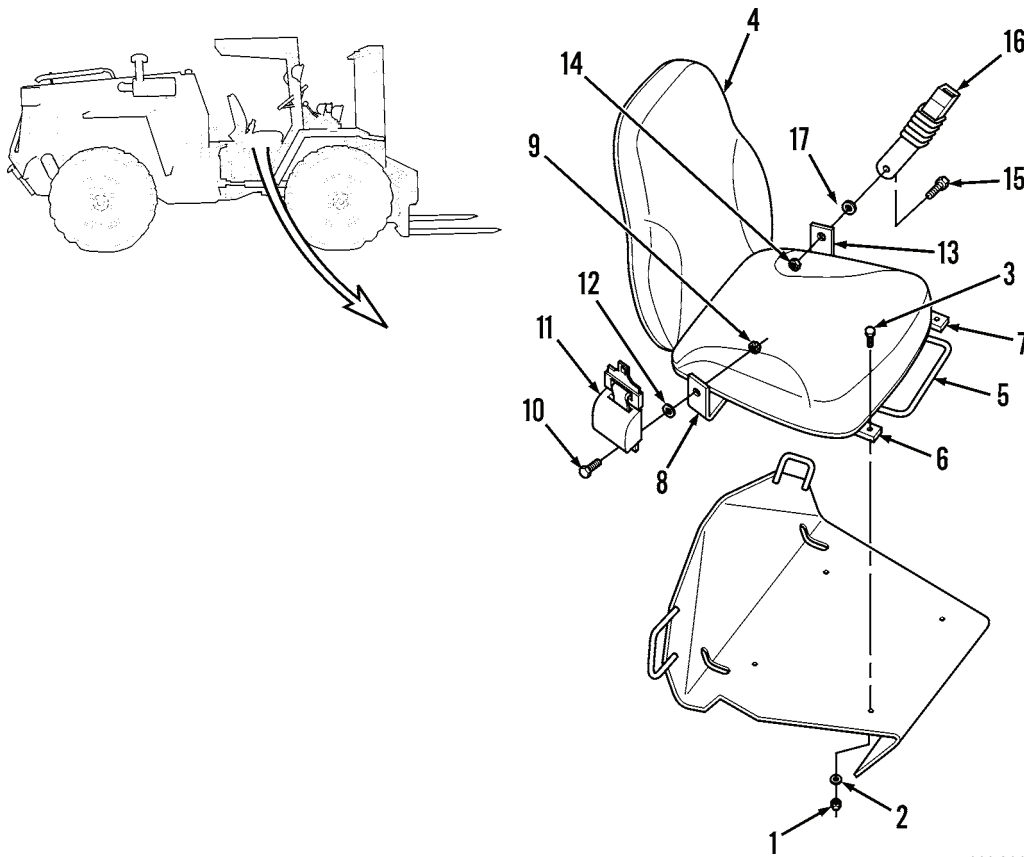

444-0145

**Figure 1. Operator's Seat.****END OF TASK****DISASSEMBLY**

1. Remove locknut (Figure 1, Item 9), cap screw (Figure 1, Item 10), right seat belt (Figure 1, Item 11), and washer (Figure 1, Item 12) from right seat belt bracket (Figure 1, Item 8). Discard locknut.
2. Remove locknut (Figure 1, Item 14), cap screw (Figure 1, Item 15), left seat belt (Figure 1, Item 16), and washer (Figure 1, Item 17) from left seat belt bracket (Figure 1, Item 13). Discard locknut.

**END OF TASK**

**CLEANING**

1. Clean operator's seat and seat belts with mild detergent and water. Dry thoroughly.

**WARNING**

Solvent cleaning compound MIL-PRF-680 Type III is an environmentally compliant and low toxic material. However, it may be irritating to the eyes and skin. Use protective gloves and goggles. Use in well-ventilated areas. Keep away from open flames and other sources of ignition. Failure to do so may result in injury or death to personnel.

2. Clean all other parts with solvent cleaning compound. Dry thoroughly.

**END OF TASK****INSPECTION**

1. Inspect operator's seat. Replace if damaged, worn, cracked, or slit.
2. Inspect seat belts. Replace if damaged, worn, slit, or buckles are damaged.
3. Inspect mounting hardware. Replace if worn, cracked, distorted, or threads are damaged

**END OF TASK****ASSEMBLY**

1. Install left seat belt (Figure 1, Item 16) on left seat belt bracket (Figure 1, Item 13) with washer (Figure 1, Item 17), capscrew (Figure 1, Item 15), and new locknut (Figure 1, Item 14).
2. Install right seat belt (Figure 1, Item 11) on right seat belt bracket (Figure 1, Item 8) with washer (Figure 1, Item 12), capscrew (Figure 1, Item 10), and new locknut (Figure 1, Item 9).

**END OF TASK****INSTALLATION**

1. Position operator's seat assembly (Figure 1, Item 4) in vehicle.
2. Raise seat adjuster bar (Figure 1, Item 5) and adjust position of seat adjusters (Figure 1, Items 6 and 7) for access to four holes in vehicle.
3. Install operator's seat (Figure 1, Item 4) in vehicle with four socket head capscrews (Figure 1, Item 3), new lockwashers (Figure 1, Item 2), and nuts (Figure 1, Item 1).

**END OF TASK****END OF WORK PACKAGE**



---

## ORGANIZATIONAL MAINTENANCE INSTRUCTIONS

### NOISE Baffle MAT REPLACEMENT

#### Removal, Installation

---

#### INITIAL SETUP

**Maintenance Level**

Organizational

**Tools and Special Tools**

Tool kit, general mechanic's (Item 15, WP 0309)

Shop equipment, common no. 1 (Item 2, WP 0309)

**Materials/Parts**

Rag, wiping (Item 26, WP 0310)

Lockwasher (2)

**Equipment Condition**

Vehicle parked on level surface

Engine OFF

Parking brake applied

---

---

**REMOVAL**

1. Remove nut (Figure 1, Item 1) and lockwasher (Figure 1, Item 2) from mat support rod (Figure 1, Item 5). Discard lockwasher.
2. Remove mat support rod (Figure 1, Item 5) from opposite side of instrument panel.
3. Remove nut (Figure 1, Item 3) and lockwasher (Figure 1, Item 4) from mat support rod (Figure 1, Item 5). Discard lockwasher.
4. Remove four capscrews (Figure 1, Item 6) and washers (Figure 1, Item 7) from mounting strap (Figure 1, Item 8).
5. Remove mounting strap (Figure 1, Item 8) from vehicle.
6. Remove noise baffle mat (Figure 1, Item 9) from vehicle.

**END OF TASK****INSTALLATION**

1. Position noise baffle mat (Figure 1, Item 9) on edge of instrument panel.
2. Position mounting strap (Figure 1, Item 8) on noise baffle mat (Figure 1, Item 9).
3. Install four washers (Figure 1, Item 7) and capscrews (Figure 1, Item 6) on mounting strap (Figure 1, Item 8).
4. Position new lockwasher (Figure 1, Item 4) and nut (Figure 1, Item 3) on end of mat support rod (Figure 1, Item 5).
5. Install mat support rod (Figure 1, Item 5) from one side of instrument panel.
6. Install new lockwasher (Figure 1, Item 2) and nut (Figure 1, Item 1) on end of mat support rod (Figure 1, Item 5).

INSTALLATION - CONTINUED

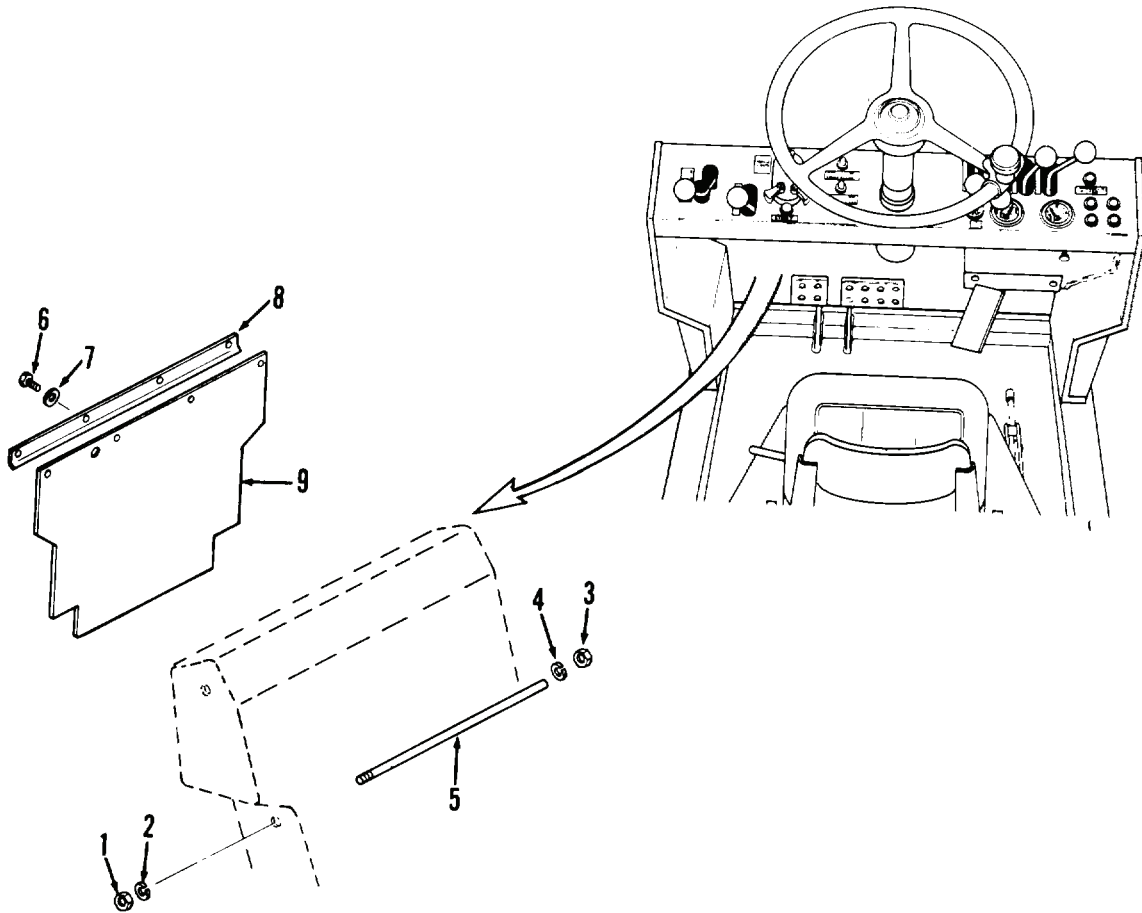

Figure 1. Noise Baffle Mat.

END OF TASK

END OF WORK PACKAGE





---

## ORGANIZATIONAL MAINTENANCE INSTRUCTIONS

### CHASSIS FLOOR PLATE AND GUARD REPLACEMENT

Removal, Cleaning, Inspection, Installation

---

#### INITIAL SETUP

**Maintenance Level**

Organizational

**Tools and Special Tools**

Tool kit, general mechanic's (Item 15, WP 0309)

Shop equipment, common no. 1 (Item 2, WP 0309)

**Materials/Parts**

Cleaning compound, solvent (Item 10, WP 0310)

**Materials/Parts - Continued**

Rag, wiping (Item 26, WP 0310)

Lockwasher (10)

**Equipment Condition**

Vehicle parked on level surface

Engine OFF

Parking brake applied

---

**REMOVAL**

1. Remove four hex nuts (Figure 1, Item 1), lockwashers (Figure 1, Item 2), washers (Figure 1, Item 3), and capscrews (Figure 1, Item 4) from guard (Figure 1, Item 5). Discard lockwashers.
2. Remove guard (Figure 1, Item 5) from vehicle.
3. Remove six capscrews (Figure 1, Item 6), lockwashers (Figure 1, Item 7), and washers (Figure 1, Item 8) from floor plate (Figure 1, Item 9). Discard lockwashers.
4. Remove floor plate (Figure 1, Item 9) from vehicle.

**END OF TASK****CLEANING****WARNING**

- Solvent cleaning compound MIL-PRF-680 Type III is an environmentally compliant and low toxic material. However, it may be irritating to the eyes and skin. Use protective gloves and goggles. Use in well-ventilated areas. Keep away from open flames and other sources of ignition. Failure to do so may result in injury or death to personnel.
- Particles blown by compressed air are hazardous. DO NOT exceed 15 PSI (103 kPa) nozzle pressure when drying parts with compressed air. DO NOT direct compressed air against human skin. Make sure air stream is directed away from user and other personnel in the area. To prevent injury, user must wear protective goggles or face shield. Failure to follow this warning may result in injury to personnel.

Use solvent cleaning compound to clean all parts. Dry thoroughly with compressed air.

**END OF TASK****INSPECTION**

1. Inspect capscrews (Figure 1, Items 4 and 6), hex nuts (Figure 1, Item 1), and washers (Figure 1, Items 3 and 8). Replace if worn, or if threads damaged.
2. Inspect guard (Figure 1, Item 5) and floor plate (Figure 1, Item 9). Repair small cracks by welding. Replace if severely cracked or damaged.

**END OF TASK****INSTALLATION**

1. Position floor plate (Figure 1, Item 9) in vehicle. Guide slots on floor plate over pedals and lower onto chassis.
2. Install six washers (Figure 1, Item 8), new lockwashers (Figure 1, Item 7), and capscrews (Figure 1, Item 6) on floor plate (Figure 1, Item 9). Tighten capscrews.

## INSTALLATION - CONTINUED

## NOTE

Use hydraulic jack, blocks, or assistants to hold guard against bottom of chassis.

3. Position guard (Figure 1, Item 5) and install four capscrews (Figure 1, Item 4), washers (Figure 1, Item 3), new lockwashers (Figure 1, Item 2), and hex nuts (Figure 1, Item 1). Tighten hex nuts.

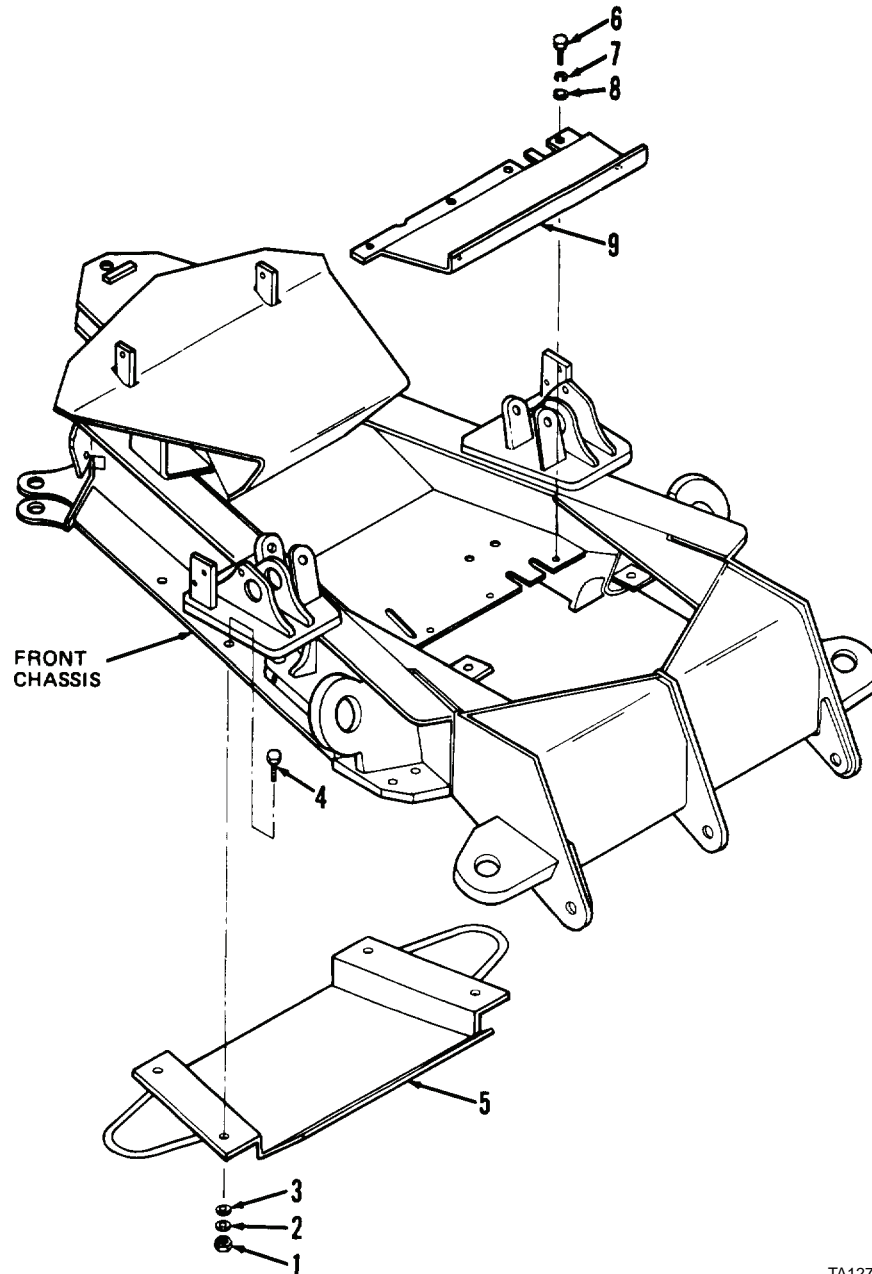

TA127039

Figure 1. Chassis Floor Plate and Guard.

END OF TASK

END OF WORK PACKAGE



---

## ORGANIZATIONAL MAINTENANCE INSTRUCTIONS

### STOWAGE BOX REPLACEMENT (MODEL 4-390)

Removal, Cleaning, Installation

---

#### INITIAL SETUP

##### Maintenance Level

Organizational

##### Tools and Special Tools

Tool kit, general mechanic's (Item 15, WP 0309)

Shop equipment, common no. 1 (Item 2, WP 0309)

##### Materials/Parts

Detergent, liquid (Item 13, WP 0310)

Rag, wiping (Item 26, WP 0310)

Locknut (4)

Water

##### Equipment Condition

Engine OFF

---

**REMOVAL**

1. At rear of left-front fender, open lid of stowage box (Figure 1, Item 1).
2. While supporting stowage box (Figure 1, Item 1), remove four locknuts (Figure 1, Item 2), eight washers (Figure 1, Item 3), and four capscrews (Figure 1, Item 4). Discard locknuts.
3. Remove stowage box (Figure 1, Item 1) from fender.

**END OF TASK****CLEANING**

Clean stowage box with detergent and water. Dry with clean rags.

**END OF TASK****INSTALLATION**

1. Position stowage box (Figure 1, Item 1) on left-front fender.
2. Install four capscrews (Figure 1, Item 4), eight washers (Figure 1, Item 3), and four new locknuts (Figure 1, Item 2).
3. Close lid of stowage box (Figure 1, Item 1).

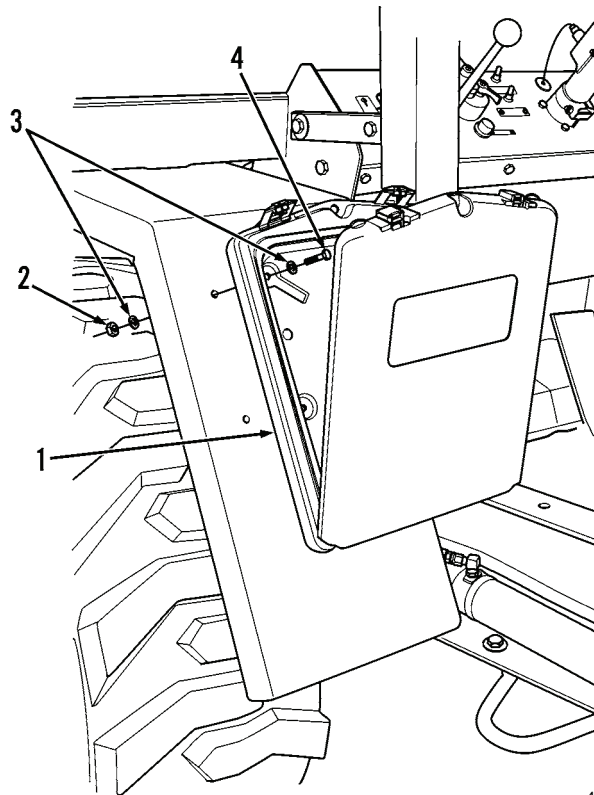

444-0149

**Figure 1. Stowage Box.**

**END OF TASK****END OF WORK PACKAGE**

# ORGANIZATIONAL MAINTENANCE INSTRUCTIONS

## HYDRAULIC LIFT SYSTEM OPERATIONAL TEST

### Operational Test

#### INITIAL SETUP

##### Maintenance Level

Organizational

##### Tools and Special Tools

Tool kit, general mechanic's (Item 15, WP 0309)

Shop equipment, common no. 1 (Item 2, WP 0309)

##### Materials/Parts

Rag, wiping (Item 26, WP 0310)

##### References

LO 10-3930-638-12

WP 0193

WP 0194

WP 0195

WP 0196

WP 0198

##### Equipment Condition

Vehicle parked on level surface

Parking brake applied

Engine OFF

#### OPERATIONAL TEST

#### NOTE

This procedure provides an operational test of the control valve, associated cylinders (lift, tilt, rotation, and sideshift), and hoses, lines, and fittings. This procedure may also be used to quickly troubleshoot the mast assembly to determine what components are defective.

1. Check hydraulic reservoir oil level; add hydraulic oil if oil level is not between FULL and ADD marks on dipstick with mast lowered (WP 0198).
2. Start engine and operate at idle speed.
3. Place lift control lever in RAISE position; release lever when mast reaches full height.
  - a. If mast moves upward smoothly, proceed to step 4.
  - b. If mast does not move properly, check hoses, lines, and fittings between control valve and lift cylinder assembly for oil leaks. Tighten loose fittings/replace leaking hose (WP 0195 and WP 0196). Check lift chains and pulleys for wear or damage; replace as necessary (WP 0193). If hoses, lines, fittings, lift chains, and pulleys are okay, notify Direct Support Maintenance.
4. Place tilt control lever in FWD position; release when mast is in full forward position.
  - a. Mast moves forward smoothly, proceed to step 7.
  - b. If mast does not move properly, proceed to step 5.
5. With mast in full forward position, disconnect fitting at rod end of tilt cylinder assemblies and plug fitting. Place tilt control lever in FWD position and hold.
  - a. If there is no oil leakage at tilt cylinder assemblies port where fitting disconnected, reconnect fitting to tilt cylinder assemblies. Proceed to step 6.
  - b. If leakage is present, notify Direct Support Maintenance (tilt cylinder assembly requires replacement).
6. Check hoses, lines, and fittings between control valve and tilt cylinder assemblies for oil leaks.
  - a. If no oil leaks are found, notify Direct Support Maintenance (control valve requires replacement).
  - b. If leakage is present, tighten fittings; replace leaking hoses (WP 0195 and WP 0196).

**OPERATIONAL TEST - CONTINUED**

7. Place tilt control lever in REAR position; release when mast is in full rearward position.
  - a. If mast moves rearward smoothly, proceed to step 8.
  - b. If mast does not move properly, repeat step 5.
8. Place tilt control lever in FWD position; release lever when mast is in vertical position.
9. Place lift control lever in LOWER position; release when forks are touching ground.
  - a. If mast moves downward smoothly, proceed to step 10.
  - b. If mast does not move properly, replace restrictor (WP 0195).
10. Position vehicle to pick up a 4,000-lb (1,814 kg) load. Place lift control lever in RAISE position; release when mast is at full height. Allow mast to remain at full height for 2 minutes.
  - a. Downward drift of mast should not exceed 1 in. (25 mm). If drift is okay, proceed to step 11.
  - b. If downward drift exceeds 1 in. (25 mm), bleed air from lift cylinder assembly (WP 0195, step 27).
11. Place lift control lever in LOWER position; release lever when forks are 3 ft (91 cm) from ground. Then, place shift control lever in RIGHT position until forks are at extreme right position.
  - a. If forks shift load to right smoothly, proceed to step 14.
  - b. If forks move improperly, check sideshift chains and pulleys for wear or damage; replace as necessary (WP 0194). Proceed to step 12.
12. Place lift control lever in LOWER position until load is resting on ground. Disconnect fitting at rod end of sideshift cylinder assembly and plug fitting. Place shift control lever in RIGHT position and hold.
  - a. If there is no oil leakage at sideshift cylinder assembly port where fitting disconnected, reconnect fitting to sideshift cylinder assembly. Proceed to step 13.
  - b. If leakage is present, notify Direct Support Maintenance (sideshift cylinder requires replacement).
13. Check hoses, lines, and fittings between control valve and sideshift cylinder assembly for oil leaks.
  - a. If no oil leaks are found, notify Direct Support Maintenance (control valve requires replacement).
  - b. If leakage present, tighten fittings; replace leaking hoses (WP 0195 and WP 0196).
14. Place shift control lever in LEFT position until forks are at extreme left position.
  - a. If forks shift load to left smoothly, proceed to step 15.
  - b. If forks do not shift properly, check sideshift chains and pulleys for wear or damage; replace as necessary (WP 0194).

**NOTE**

If binding or loud noise is heard during rotation, grease lubrication fitting on rotation bearing (LO 10-3930-638-12) and repeat step 15. If condition still exists, notify Direct Support Maintenance (rotation bearing requires replacement).

15. Place lift control lever in LOWER position until load is resting on ground. Back vehicle away from load. Place lift control lever in RAISE position until forks are 3 ft (91 cm) from ground. Then, place rotate control lever in CW position until forks are rotated fully clockwise.
  - a. If forks rotate clockwise smoothly, proceed to step 18.
  - b. If forks do not rotate properly, proceed to step 16.



**OPERATIONAL TEST - CONTINUED**

16. With forks in extreme clockwise position, disconnect fitting at rod end of rotation cylinder and plug fitting. Place rotate control lever in CW position and hold.
  - a. If there is no oil leakage at rotation cylinder port where fitting disconnected, reconnect fitting to rotation cylinder and proceed to step 17.
  - b. If leakage is present, notify Direct Support Maintenance (rotation cylinder requires replacement).
17. Check hoses, lines, and fittings between control valve and rotation cylinder assembly for oil leaks.
  - a. If there are no oil leaks, notify Direct Support Maintenance (control valve requires replacement).
  - b. If leakage is present, tighten fittings; replace leaking hoses (WP 0195 and WP 0196).

**NOTE**

If binding or loud noise is heard during rotation, grease lubrication fitting on rotation bearing (LO 10-3930-638-12) and repeat step 18. If condition still exists, notify Direct Support Maintenance (rotation bearing requires replacement).

18. Place rotate control lever in CCW position until forks are rotated fully counterclockwise.
  - a. If forks rotate counterclockwise smoothly, proceed to step 19.
  - b. If forks do not rotate properly, repeat step 16.
19. Turn engine OFF and check hydraulic reservoir oil level; add hydraulic oil if necessary (WP 0198).

**END OF TASK****END OF WORK PACKAGE**



---

## ORGANIZATIONAL MAINTENANCE INSTRUCTIONS

### HYDRAULIC CONTROL LEVERS AND LINKAGES MAINTENANCE

Removal, Cleaning, Inspection, Repair, Installation/Replacement

---

#### INITIAL SETUP

##### Maintenance Level

Organizational

##### Tools and Special Tools

Tool kit, general mechanic's (Item 15, WP 0309)  
Shop equipment, common no. 1 (Item 2, WP 0309)  
Bore gage, 0 to 1 in. range

##### Materials/Parts

Cleaning compound, solvent (Item 10, WP 0310)  
Cloth, crocus (Item 12, WP 0310)  
Rag, wiping (Item 26, WP 0310)

##### Materials/Parts - Continued

Cotter pin (8)  
Retaining ring (2)

##### References

LO 10-3930-638-12

##### Equipment Condition

Vehicle parked on level surface  
Forks lowered and resting on ground  
Mast vertical  
Engine OFF  
Parking brake applied.  
Noise baffle mat removed (WP 0187)

---

**REMOVAL**

1. Remove four knobs (Figure 1, Item 1) from control levers (Figure 1, Items 9, 11, 13, and 15) on instrument panel.
2. Remove four cotter pins (Figure 1, Item 2) from control valve spools at bottom of instrument panel. Discard cotter pins.
3. Remove four clevis pins (Figure 1, Item 3) from valve links (Figure 1, Item 7).
4. On work bench, remove control levers (Figure 1, Items 9, 11, 13, and 15) as an assembly from bottom of instrument panel.
5. Remove four cotter pins (Figure 1, Item 4) from clevis pins (Figure 1, Item 5). Discard cotter pins.
6. Remove four clevis pins (Figure 1, Item 5) from valve links (Figure 1, Item 7).
7. Remove eight valve links (Figure 1, Items 6 and 7) from assembly.
8. Remove retaining ring (Figure 1, Item 8) from bearings (Figure 1, Item 18). Discard retainer ring.
9. Remove tilt control lever (Figure 1, Item 9) from assembly.
10. Remove washer (Figure 1, Item 10) from assembly.
11. Remove lift control lever (Figure 1, Item 11) from assembly.
12. Remove washer (Figure 1, Item 12) from assembly.
13. Remove shift control lever (Figure 1, Item 13) from assembly.
14. Remove washer (Figure 1, Item 14) from assembly.
15. Remove rotate control lever (Figure 1, Item 15) from assembly.
16. Remove retaining ring (Figure 1, Item 16) and pivot shaft (Figure 1, Item 17) from assembly. Discard retaining ring.

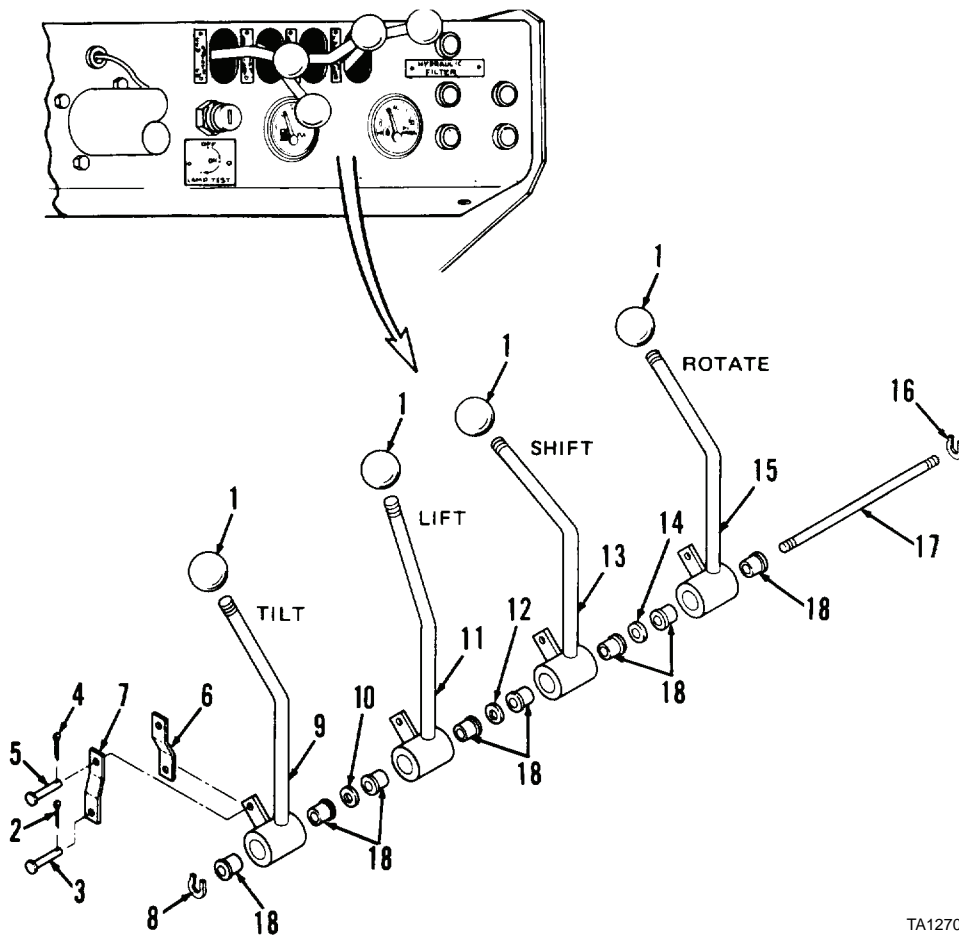

Figure 1. Hydraulic Control Levers and Linkages.

TA127041

**END OF TASK**

**CLEANING****WARNING**

Solvent cleaning compound MIL-PRF-680 Type III is an environmentally compliant and low toxic material. However, it may be irritating to the eyes and skin. Use protective gloves and goggles. Use in well-ventilated areas. Keep away from open flames and other sources of ignition. Failure to do so may result in injury or death to personnel.

Use solvent cleaning compound to clean all parts.

**END OF TASK****INSPECTION**

1. Inspect knobs (Figure 1, Item 1). Replace if cracked, nicked, or internal threads damaged.
2. Inspect clevis pins (Figure 1, Items 3 and 5). Replace if bent, cracked, or holes elongated.
3. Inspect valve links (Figure 1, Items 6 and 7). Replace if bent, cracked, deformed, or mounting holes elongated.
4. Inspect washers (Figure 1, Items 10, 12, and 14). Replace if damaged or holes elongated.
5. Inspect pivot shaft (Figure 1, Item 17). Replace if bent or damaged. Remove nicks or scratches with fine crocus cloth.
6. Inspect control levers (Figure 1, Items 9, 11, 13, and 15). Replace if cracked or broken.
7. Inspect bearings (Figure 1, Item 18). Use bore gage and measure inside diameter; replace (see *Repair* in this work package) if inside diameter is greater than 0.690 in. (17.53 mm).

**END OF TASK****REPAIR**

1. Use punch to remove two bearings (Figure 1, Item 18) from opposite side of each control lever (Figure 1, Items 9, 11, 13, and 15).
2. Use soft hammer to install two bearings (Figure 1, Item 18). Position and tap bearings into lever tube until shoulder just touches end of tube.

**END OF TASK****INSTALLATION/REPLACEMENT**

1. Install new retaining ring (Figure 1, Item 16) on one end of pivot shaft (Figure 1, Item 17).
2. Install rotate control lever (Figure 1, Item 15) on pivot shaft (Figure 1, Item 17).
3. Install washer (Figure 1, Item 14) on pivot shaft (Figure 1, Item 17). Use as required to position rotate control lever (Figure 2, Item 15) in instrument panel slot.
4. Install shift control lever (Figure 1, Item 13) on pivot shaft (Figure 1, Item 17).
5. Install washer (Figure 1, Item 12) on pivot shaft (Figure 1, Item 17). Use as required to position shift control lever (Figure 2, Item 13) in instrument panel slot.
6. Install lift control lever (Figure 1, Item 11) on pivot shaft (Figure 1, Item 17).
7. Install washer (Figure 1, Item 10) on pivot shaft (Figure 1, Item 17). Use as required to position lift control lever (Figure 2, Item 10) in instrument panel slot.

**INSTALLATION/REPLACEMENT**

8. Install tilt control lever (Figure 2, Item 9) on pivot shaft (Figure 2, Item 17).
9. Install new retaining ring (Figure 2, Item 8) on pivot shaft (Figure 2, Item 17).
10. Position eight valve links (Figure 2, Items 6 and 7) on tabs of control levers (Figure 2, Items 9, 11, 13, and 15).
11. Install four clevis pins (Figure 2, Item 5) on valve links. Secure valve links to tabs on control levers (Figure 2, Items 9, 11, 13, and 15).
12. Install four new cotter pins (Figure 2, Item 4) on clevis pins (Figure 2, Item 5).
13. Position assembled control levers (Figure 2, Items 9, 11, 13, and 15) from beneath instrument panel.
14. Install four clevis pins (Figure 2, Item 3) on valve links (Figure 2, Items 6 and 7) and control levers (Figure 2, Items 9, 11, 13, and 15).
15. Install four new cotter pins (Figure 2, Item 2) in clevis pins (Figure 2, Item 3).
16. Install four knobs (Figure 2, Item 1) on control levers (Figure 2, Items 9, 11, 13, and 15).

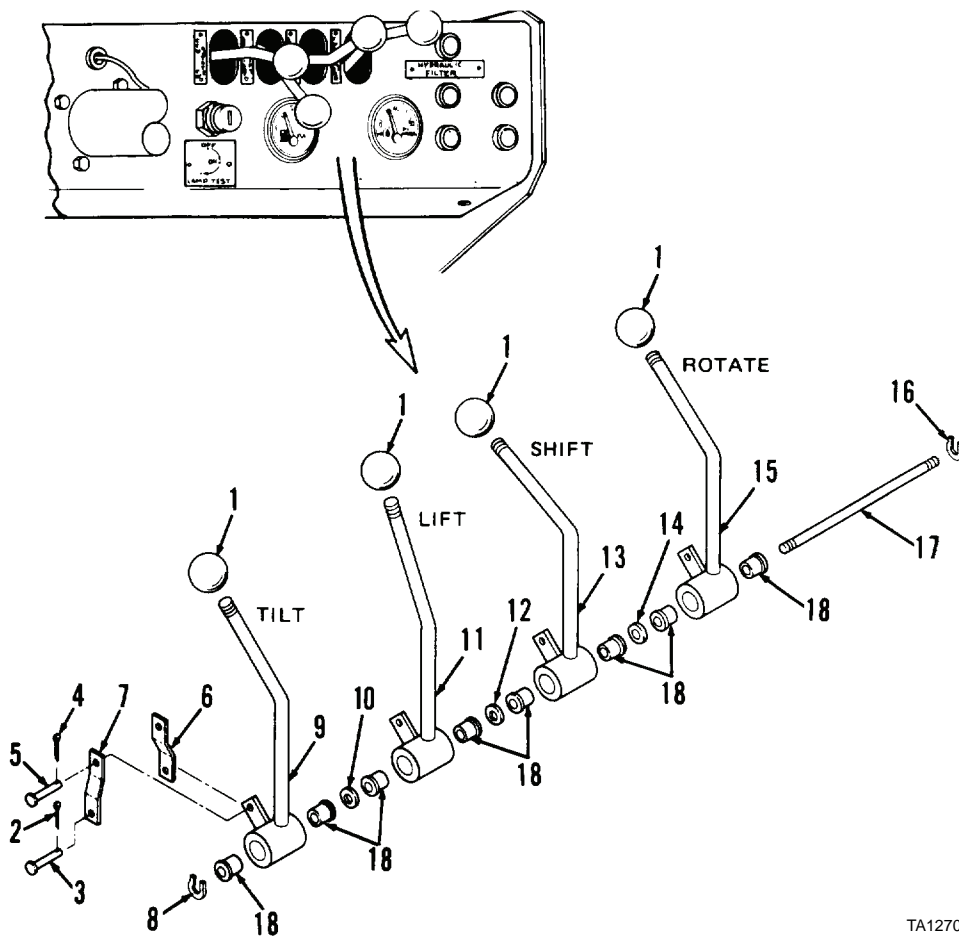

TA127041

Figure 2. Hydraulic Control Levers and Linkages.

**END OF TASK****END OF WORK PACKAGE**

---

# ORGANIZATIONAL MAINTENANCE INSTRUCTIONS

## LIFTING FORKS REPLACEMENT

### Removal, Installation/Replacement

---

#### INITIAL SETUP

##### Maintenance Level

Organizational

##### Tools and Special Tools

Tool kit, general mechanic's (Item 15, WP 0309)

Shop equipment, common no. 1 (Item 2, WP 0309)

Bar, 1-1/2 in. dia. x 18 in. long

Wood blocks (2), 6 x 6 x 30 in.

##### Materials/Parts

Rag, wiping (Item 26, WP 0310)

##### Equipment Condition

Vehicle parked on level surface

Lifting forks raised waist high (approximately  
3-1/2 ft from ground)

Carriage assembly blocked so it will not fall

Engine OFF

Parking brake applied

Placard placed on control valve levers indicating  
levers are not to be operated

---

**REMOVAL**

1. Remove capscrew and nut from carriage assembly (Figure 1).
2. Position fork travel bar on left carriage assembly. Use 1-1/2 in. diameter bar and hammer to drive bar far enough through bore on opposite side of carriage to remove fork.
3. Lift end of lifting fork to disengage from notch in support and slide fork from bar.
4. Position fork travel bar on right carriage assembly. Use 1-1/2 in. diameter bar and hammer to drive bar far enough through bore on opposite side of carriage to remove fork.
5. Repeat step 3.

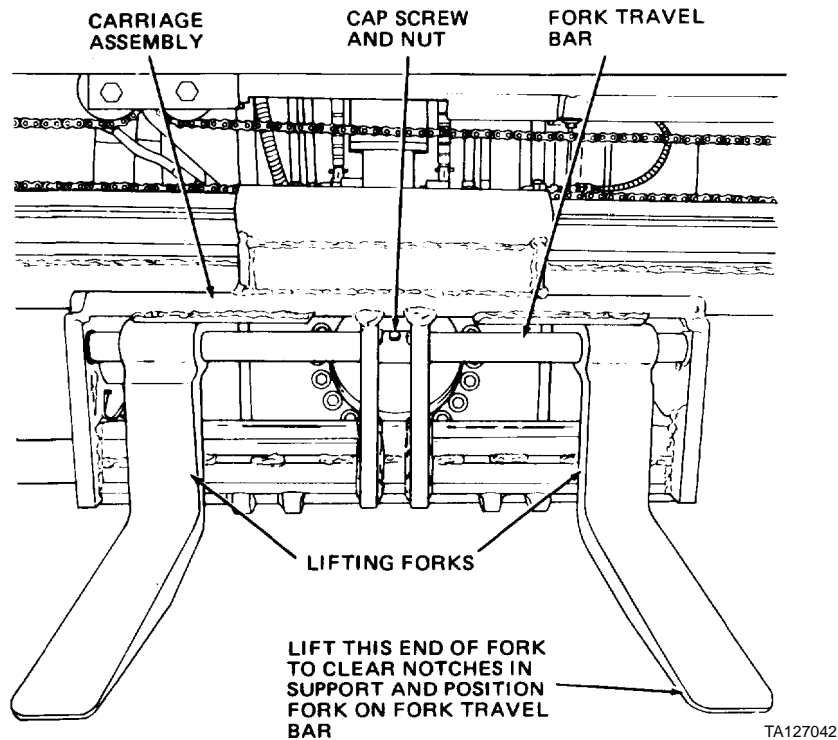
**Figure 1. Lifting Forks.****END OF TASK**



---

**INSTALLATION/REPLACEMENT****WARNING**

Use extreme caution when manually adjusting position of lifting forks. Avoid crushing fingers or hands by keeping hands away from pinch points. Failure to do so may result in serious injury.

1. Install lifting fork on fork travel bar at front right of carriage assembly (Figure 1). If necessary, perform *Removal*, step 2 in this work package to position bar. Be sure to lift end of fork to clear notches in support.
2. Position fork travel bar on left side of carriage assembly. Use 1-1/2 in. diameter bar and hammer to drive bar into its bore on opposite side of carriage. Continue driving bar far enough through bore until remaining fork can be installed.
3. Install lifting fork on fork travel bar at front left of carriage assembly. Be sure you lift end of fork to clear notches in support.
4. Position fork travel bar on right side of carriage assembly. Drive bar into its bore on opposite side of carriage until holes in bar and center of carriage are aligned.
5. Install capscrew and nut at middle of carriage assembly.

**END OF TASK****END OF WORK PACKAGE**



---

# ORGANIZATIONAL MAINTENANCE INSTRUCTIONS

## LIFT CHAINS AND PULLEYS MAINTENANCE

Removal, Cleaning, Inspection, Installation/Replacement, Adjustment

---

### INITIAL SETUP

#### Maintenance Level

Organizational

#### Tools and Special Tools

Tool kit, general mechanic's (Item 15, WP 0309)  
Shop equipment, common no. 1 (Item 2, WP 0309)  
Arbor press  
Bore gage, 2-in. capacity  
Sleeve, 13/16-in. dia. x 12 in. long  
Sleeve, 2-7/32-in. dia. x 12 in. long

#### Materials/Parts

Cap set, protective (Item 9, WP 0310)  
Cleaning compound, solvent (Item 10, WP 0310)

#### Materials/Parts - Continued

Lubricating oil, OE/HDO-10 (Item 20, WP 0310)  
Rag, wiping (Item 26, WP 0310)  
Tag, marker (Item 33, WP 0310)  
Lockwasher (6)

#### References

WP 0196

#### Equipment Condition

Vehicle parked on level surface  
Engine OFF  
Parking brake applied  
Mast vertical  
Forks resting on ground  
Control valve control levers operated several times  
to relieve hydraulic pressure

---

## REMOVAL



## WARNING

Solvent cleaning compound MIL-PRF-680 Type III is an environmentally compliant and low toxic material. However, it may be irritating to the eyes and skin. Use protective gloves and goggles. Use in well-ventilated areas. Keep away from open flames and other sources of ignition. Failure to do so may result in injury or death to personnel.

## NOTE

Tag and cap all hoses.

1. Disconnect four hose fittings on inner mast of mast assembly (Figure 1). Use solvent cleaning compound to clean hose fittings.
2. Install 1/4-20 nut on each of four tension tubes to hold tension tubes in position.

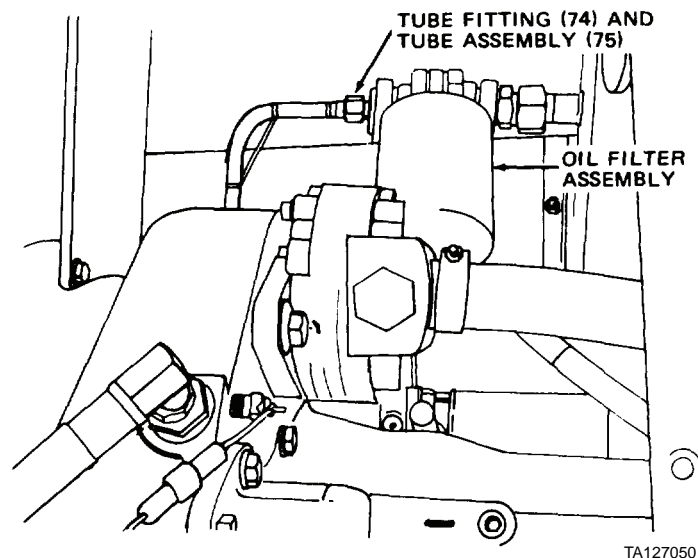

TA127050

Figure 1. Inner Mast Assembly.

**REMOVAL - CONTINUED**

3. Remove two nuts (Figure 2, Item 3), lockwashers (Figure 2, Item 3A), and capscrews (Figure 2, Item 4) from lift cylinder assembly. Discard lockwashers.

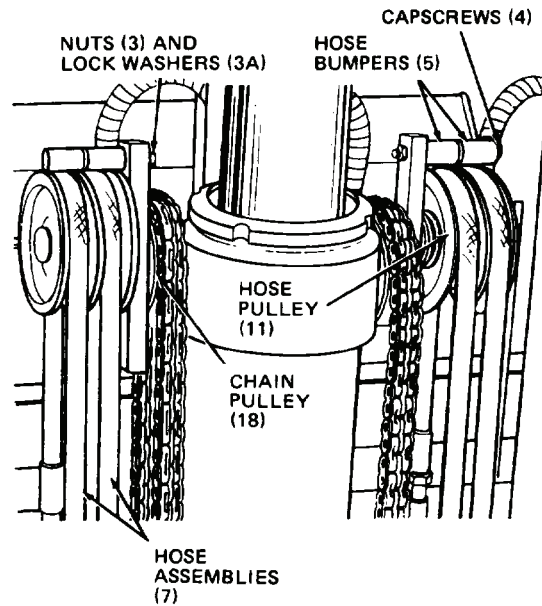

SERIAL NUMBER 9150573 AND ABOVE

TA301525

**Figure 2. Lift Chains and Pulleys.**

4. Remove four hose bumpers (Figure 3, Item 5) and two hose separators (Figure 3, Item 6) (if equipped).
5. Position four hose assemblies (Figure 3, Item 7) aside.
6. Slowly loosen and remove two lift chain nuts from lift cylinder assembly.

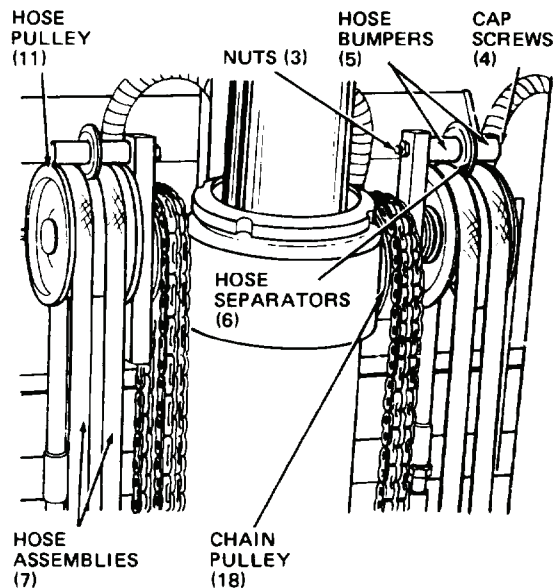

SERIAL NUMBER 9150572 AND BELOW

TA127061

**Figure 3. Lift Chains, Hose Separators, and Pulleys.**

**REMOVAL - CONTINUED**

7. Position two lift chains (Figure 4, Item 21) aside.
8. Remove two step bolts (Figure 4, Item 9) from pulley assembly.
9. Remove four washers (Figure 4, Item 10) from pulley assembly.
10. Remove two hose pulleys (Figure 4, Item 11) from pulley assembly.

**NOTE**

Do not perform step 11 unless inspection indicates bushing requires replacement.

11. Remove bushing (Figure 4, Item 12) from pulley assembly with 13/16-in. diameter sleeve.
12. Remove six washers (Figure 4, Item 13) from pulley assembly.
13. Remove four capscrews (Figure 4, Item 14) and lockwashers (Figure 4, Item 15) (if equipped).
14. Remove pulley bar (Figure 4, Item 16) from pulley assembly.
15. Remove washer (Figure 4, Item 17) from pulley assembly.
16. Remove chain pulley (Figure 4, Item 18) from pulley assembly.

**NOTE**

Do not perform step 17 unless inspection indicates bearing requires replacement.

17. Remove bearing (Figure 4, Item 19) from pulley assembly with 2-7/32-in. diameter sleeve.

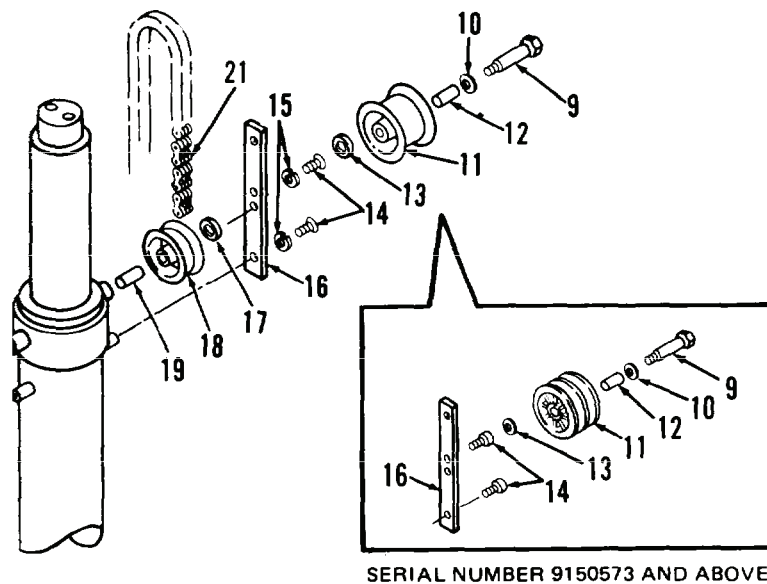

TA301526

**Figure 4. Pulley Assemblies.**

18. Remove two lift chain nuts (Figure 5, Item 20) from top of carriage bearing plate.
19. Remove two lift chains (Figure 5, Item 21) from vehicle.

REMOVAL - CONTINUED

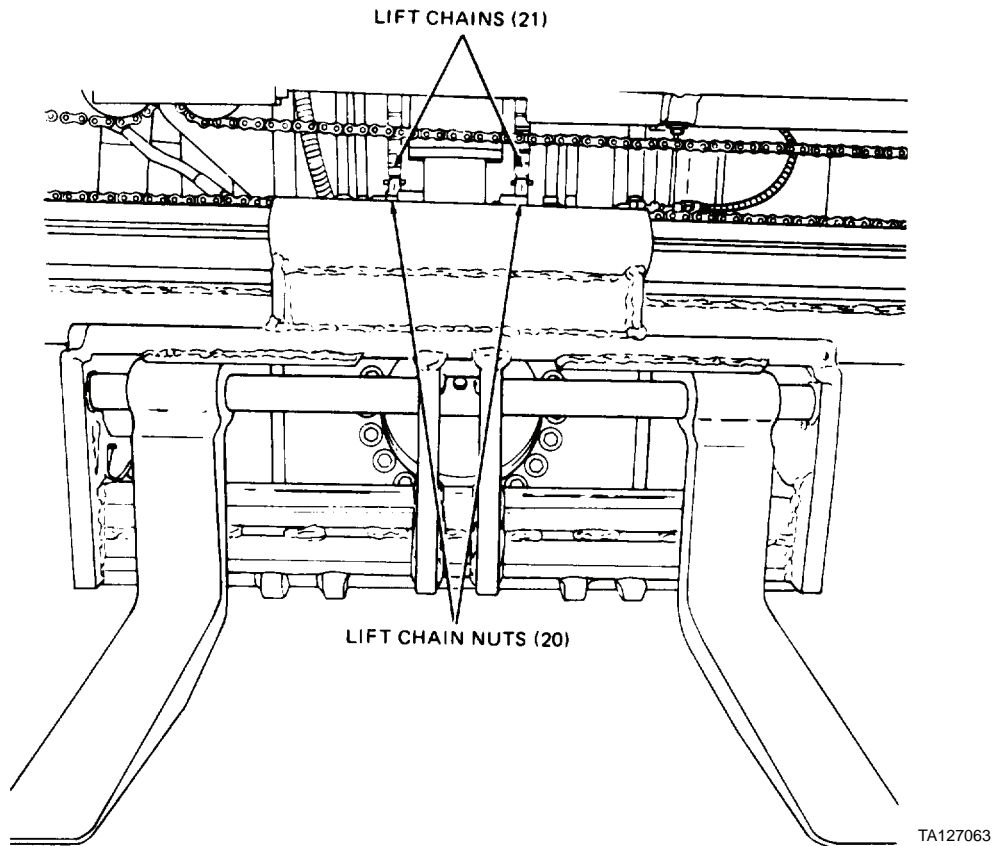

Figure 5. Lift Chains and Nuts.

END OF TASK

CLEANING



Solvent cleaning compound MIL-PRF-680 Type III is an environmentally compliant and low toxic material. However, it may be irritating to the eyes and skin. Use protective gloves and goggles. Use in well-ventilated areas. Keep away from open flames and other sources of ignition. Failure to do so may result in injury or death to personnel.

Use solvent cleaning compound to clean all parts.

END OF TASK

## INSPECTION

1. Inspect hose bumpers. Replace if cracked, chipped, or mounting holes enlarged.
2. Inspect step bolts. Replace if body is worn or cracked or if threads are damaged.
3. Inspect hose pulleys and bushings. Replace as an assembly if pulley is cracked, bent, or damaged. Replace bushing (*Removal*, step 11 in this work package) if inside diameter is 0.79 in. (20.1 mm) or more (use bore gage to measure).
4. Inspect pulley bar. Replace if bent or cracked; chase outer threaded hole with 1/4-20 tap; chase inner threaded hole with 7/16-14 tap.
5. Inspect chain pulleys and bearing. Replace as an assembly if pulley is cracked, bent, or damaged. Replace bearing (*Removal*, step 17 in this work package) if rolling action is rough or if inside diameter is 1.24 in. (31.5 mm) or more (use bore gage to measure).
6. Inspect lift chains. Replace chain if any link is broken or cracked. Replace chain bolt if threads damaged; replace pin if cracked or bent. See Figure 6 for replacement of these parts.

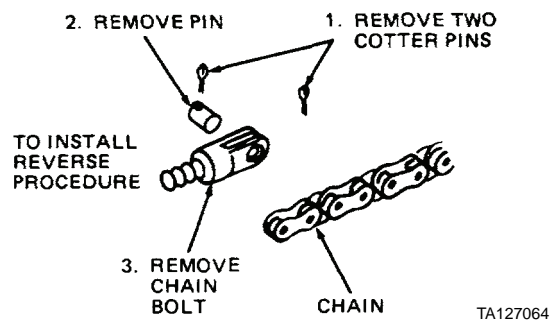

Figure 6. Lift Chain Assembly.

## END OF TASK

### INSTALLATION/REPLACEMENT

1. Soak two lift chains in lubricating oil. Position and install chain bolt in carriage bracket supports (Figure 7).
2. Install two lift chain nuts on vehicle.

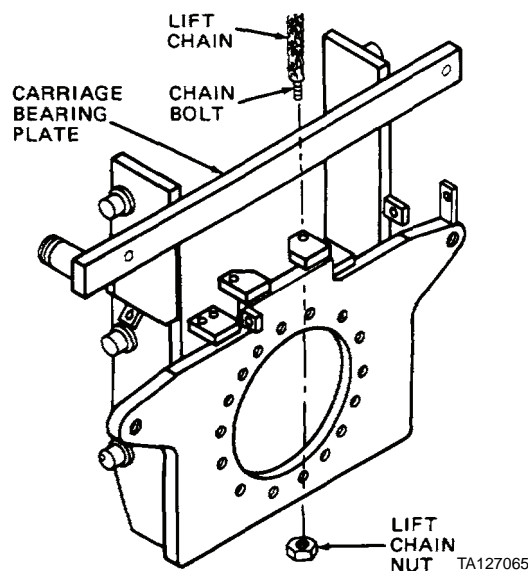
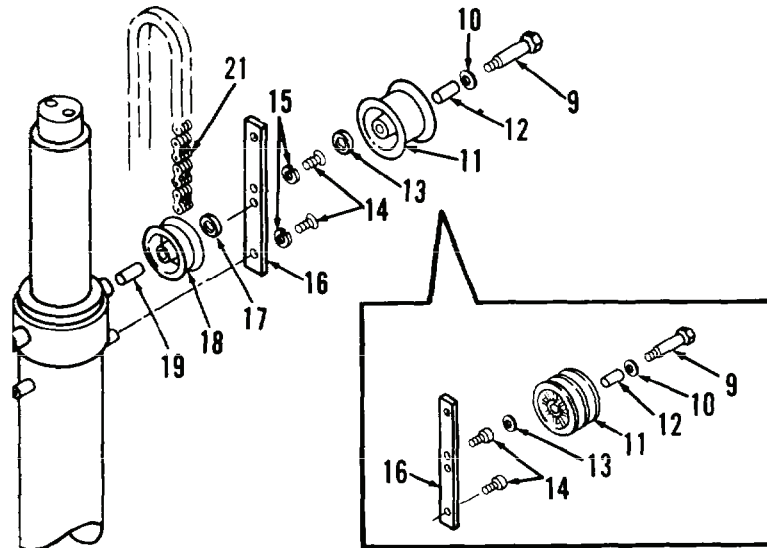

Figure 7. Carriage Bearing Plate.



**INSTALLATION/REPLACEMENT - CONTINUED**

3. Use 2-7/32-in. diameter sleeve to install chain pulley (Figure 8, Item 18) and bearing (Figure 8, Item 19). Press into chain pulley hub until centered.
4. Use 13/16-in. diameter sleeve to install hose pulley (Figure 8, Item 11) and bushing (Figure 8, Item 12). Press into hose pulley hub until centered.
5. Position chain pulley (Figure 8, Item 18) on lift cylinder assembly.
6. Position new lockwasher (Figure 8, Item 15) and capscrew (Figure 8, Item 14) in unthreaded center hole of pulley bar (Figure 8, Item 16). Use lockwasher on Serial Number 9150572 and below. Tighten capscrew to 25 to 35 lb-ft (34 to 47 Nm) (Serial Number 9150573 and above).
7. Position washer (Figure 8, Item 17) on capscrew (Figure 8, Item 14).
8. Position pulley bar (Figure 8, Item 16) and install capscrew (Figure 8, Item 14) through chain pulley (Figure 8, Item 18) hub.
9. Install new lockwasher (Figure 8, Item 15) and capscrew (Figure 8, Item 14) on pulley bar (Figure 8, Item 16). Use lockwasher on Serial Number 9150572 and below. Tighten capscrew to 25 to 35 lb-ft (34 to 47 Nm) (Serial Number 9150573 and above).
10. Loop lift chain (Figure 8, Item 21) over chain pulley. Install chain bolt in inner mast rod.
11. Install lift chain nuts on lift cylinder assembly (Figure 7). Tighten nuts until chain deflects 1/2 in. (13 mm) when depressed in middle.
12. Position two washers (Figure 8, Item 10) on step bolt (Figure 8, Item 9).
13. Position hose pulley (Figure 8, Item 11) on step bolt (Figure 8, Item 9).
14. Position three washers (Figure 8, Item 13) on step bolt (Figure 8, Item 9).
15. Install step bolt (Figure 8, Item 9) in center threaded hole of pulley bar (Figure 8, Item 16).



SERIAL NUMBER 9150573 AND ABOVE

TA301526

**Figure 8. Pulley Assemblies.**

**INSTALLATION/REPLACEMENT - CONTINUED**

16. Loop two hose assemblies over hose pulley and position near tension tubes (2).
17. Remove 1/4-20 nuts from two tension tubes.
18. Connect hose fittings to tension tube and tighten.
19. Position hose bumper on capscrew.
20. Position hose separator (if equipped) on capscrew.
21. Position second hose bumper on capscrew.
22. Install capscrew and nut with hose separator (if equipped) between two hose assemblies.

**NOTE**

Repeat steps 5 through 22 to install remaining chain and hose pulleys.

23. Perform WP 0196, *Installation/Replacement*, steps 40 through 45.

**END OF TASK**

**ADJUSTMENT**

1. Depress lift chains in middle (Figures 9 and 10). Chains should deflect approximately 1/2 in. (13 mm).
2. Tighten or loosen lift chain nuts as required to obtain 1/2-in. (13-mm) deflection when chains are depressed in middle.

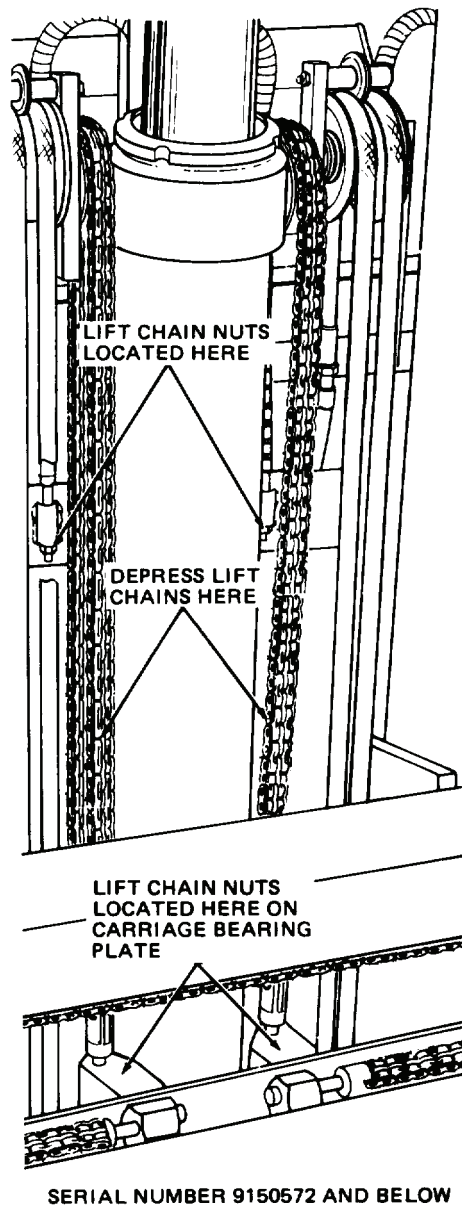
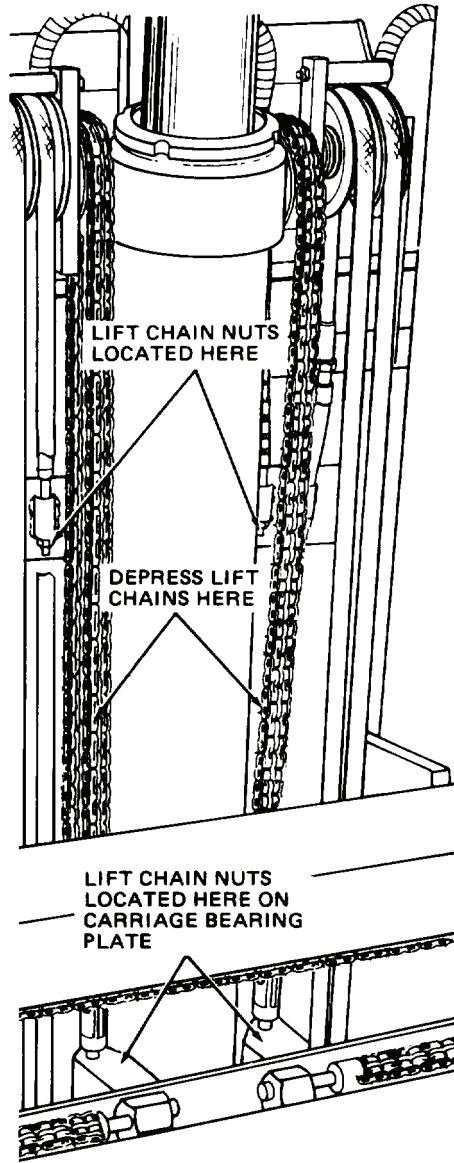

Figure 9. Lift Chain Depression Points (Serial Number 9150572 and Below).

ADJUSTMENT - CONTINUED



SERIAL NUMBER 9150573 AND ABOVE TA301527

Figure 10. Lift Chain Depression Points (Serial Number 9150573 and Above).

END OF TASK

END OF WORK PACKAGE

---

## ORGANIZATIONAL MAINTENANCE INSTRUCTIONS

### SIDESHIFT CHAINS AND PULLEYS MAINTENANCE

Removal, Cleaning, Inspection, Installation/Replacement, Adjustment

---

#### INITIAL SETUP

##### Maintenance Level

Organizational

##### Tools and Special Tools

Tool kit, general mechanic's (Item 15, WP 0309)  
Shop equipment, common no. 1 (Item 2, WP 0309)  
Arbor press  
Bore gage, 2-in. capacity  
Sleeve, 2-7/32-in. diameter x 12 in. long

##### Materials/Parts

Cleaning compound, solvent (Item 10, WP 0310)  
Lubricating oil, OE/HDO-10 (Item 20, WP 0310)  
Rag, wiping (Item 26, WP 0310)

##### Materials/Parts - Continued

Lockwasher (4)  
Retaining ring (2)

##### References

LO 10-3930-638-12

##### Equipment Condition

Vehicle parked on level surface  
Engine OFF  
Parking brake applied  
Mast vertical, forks resting on ground  
Control valve control levers operated several times  
to relieve hydraulic pressure

---

**REMOVAL**

1. Remove two sideshift chain nuts (Figure 1, Item 1) from carriage assembly.

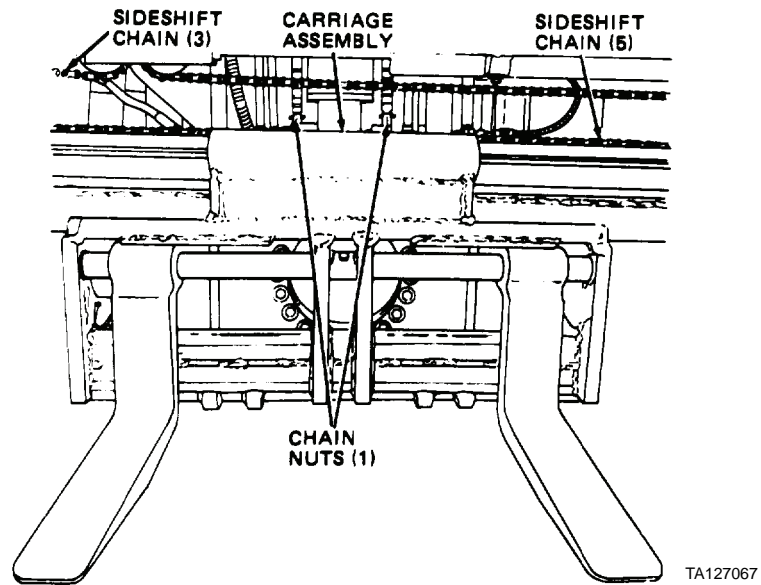

**Figure 1. Sideshift Chains and Carriage.**

2. Remove sideshift chain nut (Figure 2, Item 2) from sideshift assembly.
3. Remove sideshift chain (Figure 2, Item 3) from sideshift assembly.
4. Remove sideshift chain nut (Figure 2, Item 4) from sideshift assembly.
5. Remove sideshift chain (Figure 2, Item 5) from sideshift assembly.

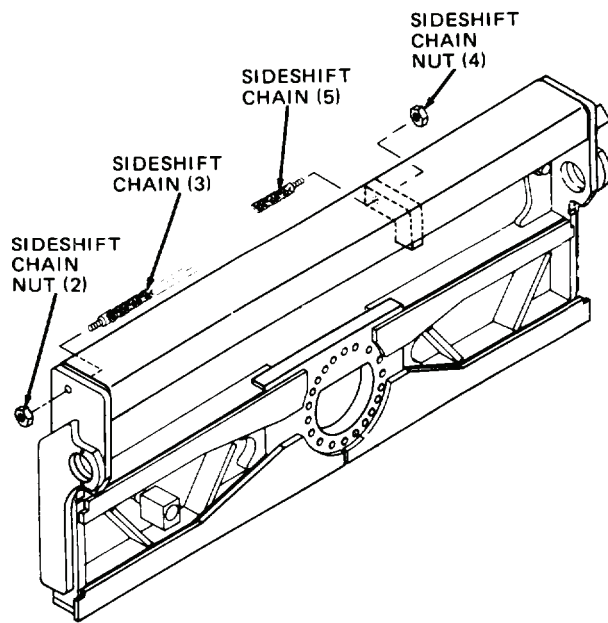

TA127068

**Figure 2. Sideshift Chains and Nuts.**

**REMOVAL - CONTINUED**

6. Remove two retaining rings (Figure 3, Item 6) from sideshift assembly. Discard retaining rings.
7. Remove two chain pulleys (Figure 3, Item 7) from sideshift assembly.

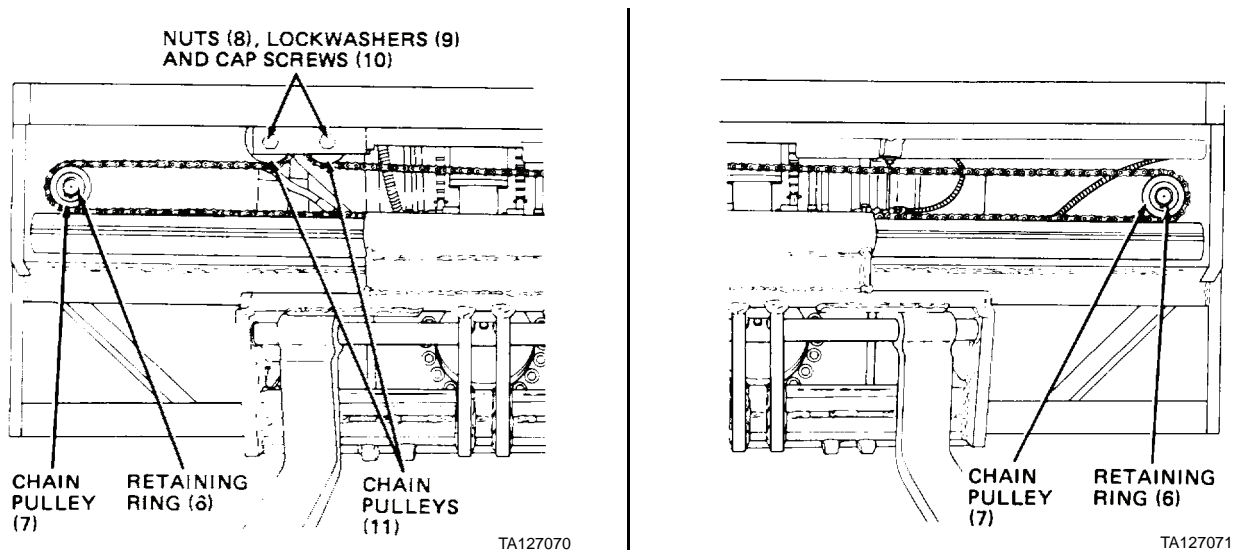

**Figure 3. Sideshift Chain and Pulleys (Right and Left Side).**

8. Remove two nuts (Figure 4, Item 8), lockwashers (Figure 4, Item 9), and capscrews (Figure 4, Item 10) from each of two chain pulley (Figure 4, Item 11) assemblies. Discard lockwashers.
9. Remove two chain pulleys (Figure 4, Item 11) from sideshift assembly.
10. Remove two spacers (Figure 4, Item 12) and eight washers (Figure 4, Item 13) from each of two chain pulleys (Figure 4, Item 11).

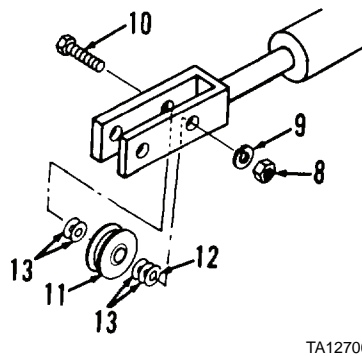

TA127069

**Figure 4. Sideshift Chain Pulleys.**

**CLEANING****WARNING**

Solvent cleaning compound MIL-PRF-680 Type III is an environmentally compliant and low toxic material. However, it may be irritating to the eyes and skin. Use protective gloves and goggles. Use in well-ventilated areas. Keep away from open flames and other sources of ignition. Failure to do so may result in injury or death to personnel.

Use solvent cleaning compound to clean all parts.

**END OF TASK****INSPECTION**

1. Inspect chain pulleys. Replace complete assembly if pulley cracked, bent, or damaged. Replace bearing if rolling action is rough or race is chipped or damaged, or if inside diameter is 0.79 in. (20 mm) or more (use bore gage to measure). Press bearing out of pulley hub using 2-7/32-in. diameter sleeve. Press new bearing into hub until centered in hub using same sleeve.
2. Inspect sideshift chains. Replace chains if any link is broken or cracked. Replace chain bolt if threads damaged; replace pin if bent or cracked. See Figure 5 for replacement of these parts.

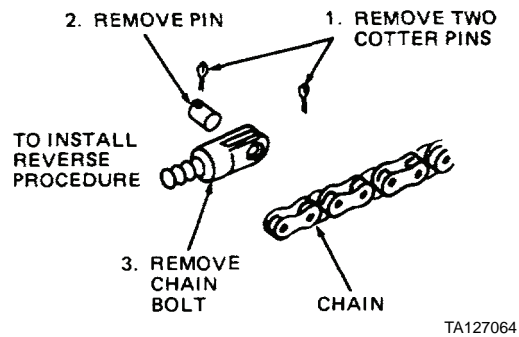

**Figure 5. Sideshift Chain Assembly.**

3. Inspect all other parts. Replace if cracked, bent, or threads damaged.

**END OF TASK**



**INSTALLATION/REPLACEMENT**

1. Position two spacers (Figure 6, Item 12) and eight washers (Figure 6, Item 13) in sideshift assembly.
2. Position two chain pulleys (Figure 6, Item 11) on sideshift assembly.
3. Install two capscrews (Figure 6, Item 10), new lockwashers (Figure 6, Item 9), and nuts (Figure 6, Item 8) in each of two chain pulley (Figure 6, Item 11) assemblies.
4. Position two chain pulleys (Figure 6, Item 7) on pulley supports.

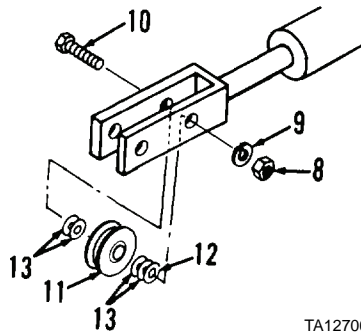

TA127069

**Figure 6. Sideshift Chain Pulleys.**

5. Install two new retaining rings (Figure 7, Item 6). Be sure rings are seated in groove.

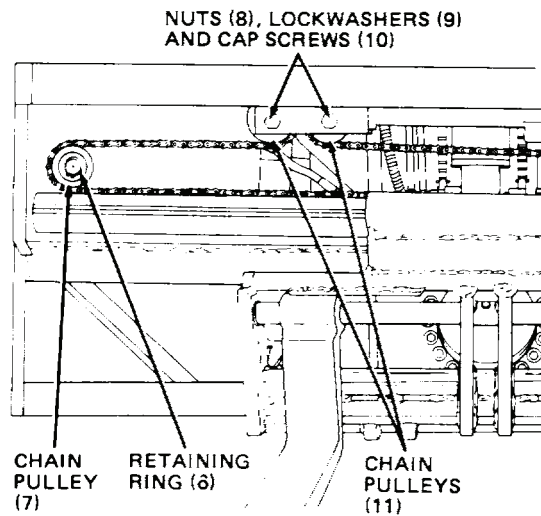

TA127070

**Figure 7. Sideshift Chain and Pulleys (Right Side).**

**INSTALLATION/REPLACEMENT - CONTINUED**

6. Soak sideshift chain (Figure 8, Item 5) in lubricating oil, then position. Insert chain bolt in sideshift cylinder support hole.
7. Install sideshift chain nut (Figure 8, Item 4) on sideshift assembly.
8. Soak sideshift chain (Figure 8, Item 3) in lubricating oil, then position. Insert chain bolt in hole on right side of sideshift assembly.
9. Install sideshift chain nut (Figure 8, Item 2) on sideshift assembly.

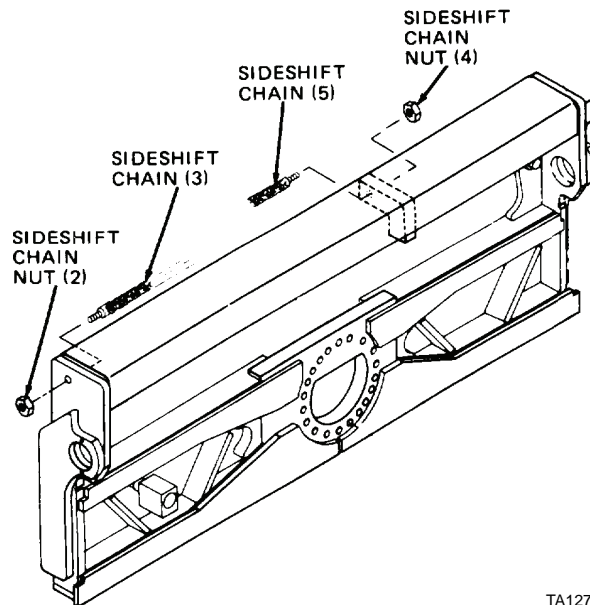

TA127068

**Figure 8. Sideshift Chains and Nuts.**

10. Route sideshift chain (Figure 9, Item 5) around and down inner pulley mounted in sideshift cylinder rod fork to pulley on left of sideshift assembly, around and down pulley to carriage assembly. Insert chain bolt in chain mounting lug on carriage assembly.
11. Route sideshift chain (Figure 9, Item 3) around and down outer pulley mounted in sideshift cylinder rod fork to pulley on right of sideshift assembly, around and down pulley to carriage assembly. Insert chain bolt in chain mounting lug on carriage assembly.

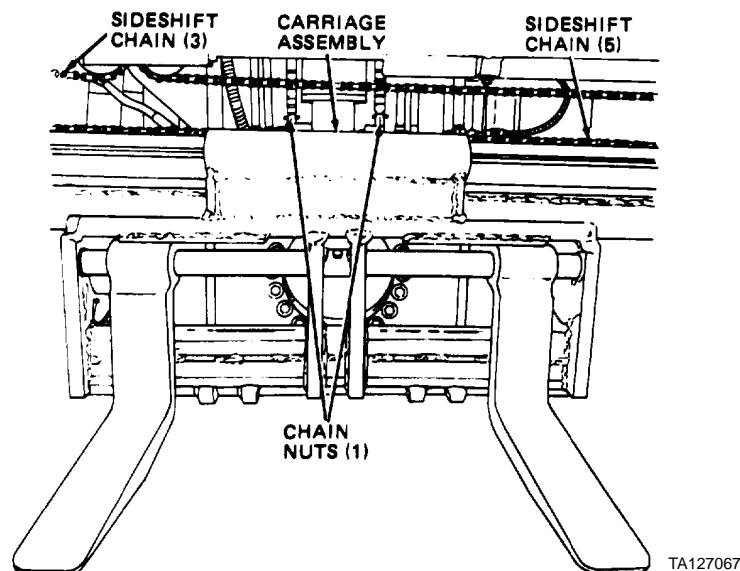

TA127067

**Figure 9. Sideshift Chains and Carriage.**

**INSTALLATION/REPLACEMENT - CONTINUED**

12. Install two carriage assembly sideshift chain nuts (Figure 10, Item 1). Tighten nuts until chain deflects approximately 1/2 in. (13 mm) when depressed in middle.

**END OF TASK****ADJUSTMENT**

1. Depress sideshift chains in middle (Figure 10). Chain should deflect approximately 1/2-in. (13 mm).
2. Tighten or loosen sideshift chain nuts as required to obtain approximately 1/2-in. (13-mm) deflection when chains are depressed in middle.

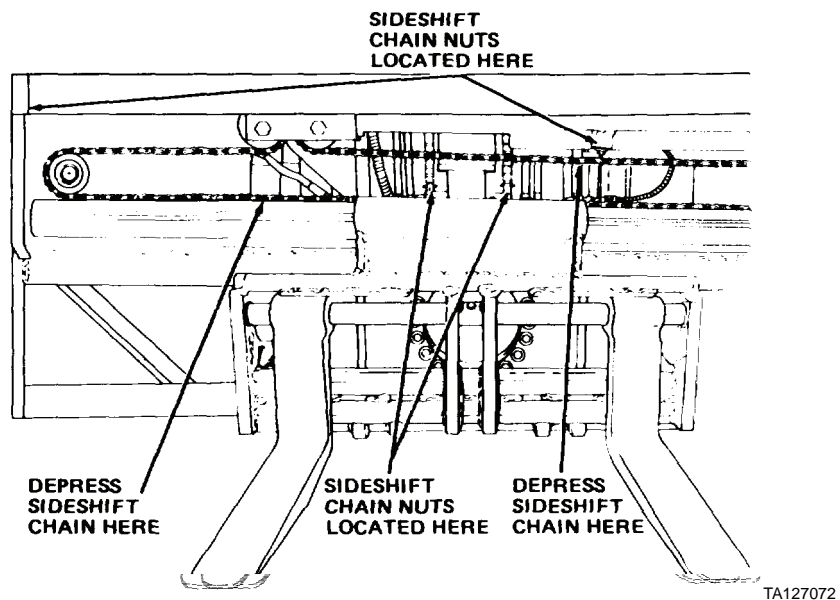

Figure 10. Sideshift Chain Depression Points.

**END OF TASK****END OF WORK PACKAGE**



---

## ORGANIZATIONAL MAINTENANCE INSTRUCTIONS

### HYDRAULIC HOSES, LINES, AND FITTINGS MAINTENANCE (HYDRAULIC OIL FILTER TO CONTROL VALVE TO MAST)

Removal, Cleaning, Inspection, Installation/Replacement, Bleeding Air from Lift Cylinder

---

#### INITIAL SETUP

##### Maintenance Level

Organizational

##### Tools and Special Tools

Tool kit, general mechanic's (Item 15, WP 0309)  
Shop equipment, common no. 1 (Item 2, WP 0309)  
Container, 12-gal. capacity

##### Materials/Parts

Cleaning compound, solvent (Item 10, WP 0310)  
Lubricating oil, OE/HDO-15/40 (Item 21, WP 0310)  
Rag, wiping (Item 26, WP 0310)  
Tag, marker (Item 33, WP 0310)  
Lockwasher (3)

##### References

WP 0198

##### Equipment Condition

Vehicle parked on level surface  
Mast tilted forward, forks resting on ground  
Mast vertical  
Engine OFF  
Parking brake applied  
Left side panel removed (WP 0179)  
Noise baffle mat removed (WP 0187)  
All control levers on control valve operated several times to relieve hydraulic pressure

---

**REMOVAL****NOTE**

Tag all hose and tube assemblies before disconnecting and removing.

1. Disconnect tube fittings (Figure 1, Items 1 and 2) from steering gear and control valve connector (Figure 1, Item 4).
2. Remove tube assembly (Figure 1, Item 3) from vehicle.
3. Remove connector (Figure 1, Item 4) from control valve.
4. Disconnect tube fitting (Figure 1, Item 5) from tee (Figure 1, Item 9).
5. Position tube assembly (Figure 1, Item 6) away from tee (Figure 1, Item 9).
6. Disconnect hose fitting (Figure 1, Item 7) from tee (Figure 1, Item 9).
7. Remove tee (Figure 1, Item 9) from tube fitting (Figure 1, Item 8).
8. Disconnect tube fitting (Figure 1, Item 10) from adapter (Figure 1, Item 12).
9. Remove tube assembly (Figure 1, Item 11) from vehicle.
10. Remove adapter (Figure 1, Item 12) from control valve.
11. Disconnect hose fittings (Figure 1, Items 13 and 14) from tees (Figure 1, Items 17 and 18).
12. Disconnect hose fittings (Figure 1, Items 15 and 16) from tees (Figure 1, Items 17 and 18).
13. Remove tees (Figure 1, Items 17 and 18) from control valve.
14. Disconnect hose fitting (Figure 1, Item 19) from elbow (Figure 1, Item 26).
15. Disconnect hose fittings (Figure 1, Items 20 and 21) from elbows (Figure 1, Items 24 and 25).
16. Disconnect hose fittings (Figure 1, Items 22 and 23) from elbows (Figure 1, Items 24 and 25).

**NOTE**

Elbows (Figure 1, Items 24, 25, and 26) are adjustable; if necessary, loosen nut (part of elbow) and extend elbow to obtain clearance to remove it.

17. Remove four elbows (Figure 1, Items 24 and 25) from control valve.
18. Remove elbow (Figure 1, Item 26) from control valve.
19. Disconnect hose fittings (Figure 1, Items 27 and 28) from right tilt cylinder assemblies.
20. Remove hose assembly (Figure 1, Item 29) from vehicle.
21. Remove hose assembly (Figure 1, Item 30) from vehicle.
22. Remove adapter (Figure 1, Item 31) from right tilt cylinder assembly.
23. Remove elbow (Figure 1, Item 32) from right tilt cylinder assembly.
24. Remove capscrew (Figure 1, Item 33), nut (Figure 1, Item 34), lockwasher (Figure 1, Item 35), and washer (Figure 1, Item 36). Discard lockwasher.
25. Remove two clamps (Figure 1, Items 37 and 39) and spacer (Figure 1, Item 38) from vehicle.
26. Disconnect hose fittings (Figure 1, Items 40 and 41) from left tilt cylinder assembly.
27. Remove hose assembly (Figure 1, Item 42) from vehicle.
28. Remove hose assembly (Figure 1, Item 43) from vehicle.
29. Remove adapter (Figure 1, Item 44) from left tilt cylinder assembly.
30. Remove elbow (Figure 1, Item 45) from left tilt cylinder assembly.

REMOVAL - CONTINUED

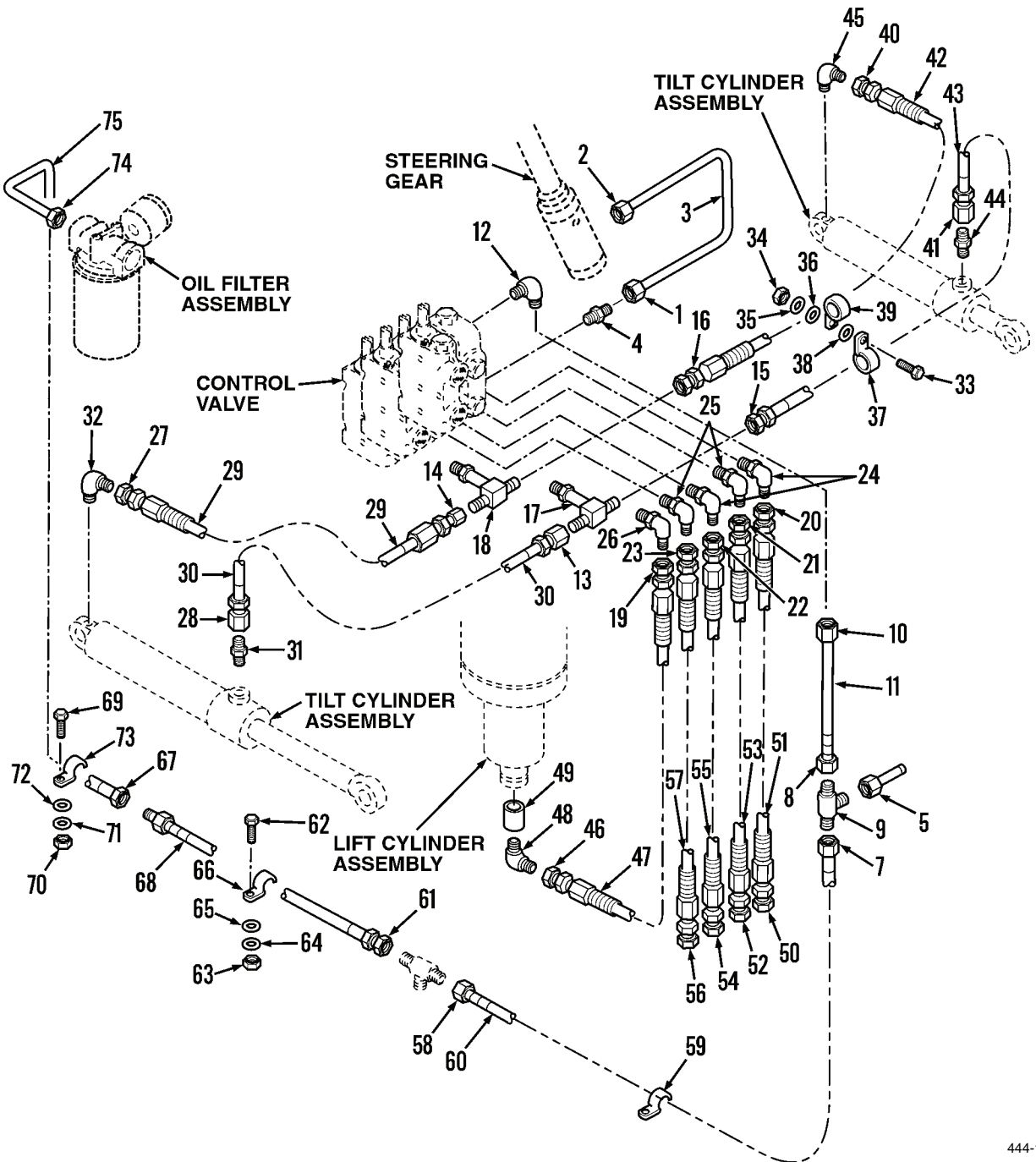

444-1187

Figure 1. Hydraulic Hoses, Lines, and Fittings.

**REMOVAL - CONTINUED**

31. Place 12-gal. (45-L) container under hose fitting (Figure 2, Item 46) and drain hydraulic oil.

**NOTE**

When performing step 32, slowly loosen fitting to relieve hydraulic pressure safely.

32. Disconnect hose fitting (Figure 2, Item 46) and remove from hose assembly (Figure 2, Item 47).

33. Remove hose assembly (Figure 2, Item 47), elbow (Figure 2, Item 48), and restrictor (Figure 2, Item 49).

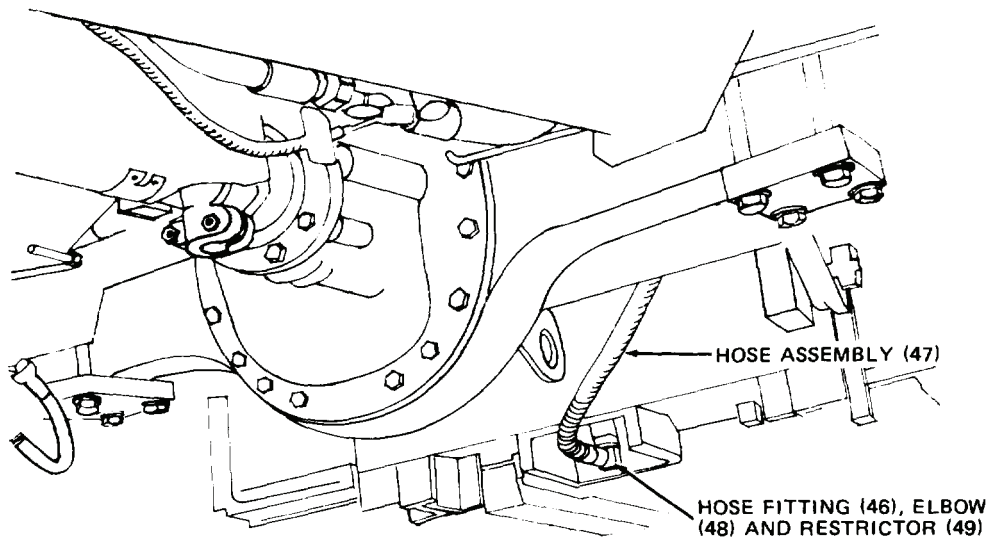

TA127046

**Figure 2. Hose Assembly and Fittings.**

34. Disconnect hose fitting (Figure 3, Item 50) from hose assembly (Figure 3, Item 51).

35. Remove hose assembly (Figure 3, Item 51) from vehicle.

36. Disconnect hose fitting (Figure 3, Item 52) from hose assembly (Figure 3, Item 53).

37. Remove hose assembly (Figure 3, Item 53) from vehicle.

38. Disconnect hose fitting (Figure 3, Item 54) from hose assembly (Figure 3, Item 55).

39. Remove hose assembly (Figure 3, Item 55) from vehicle.

40. Disconnect hose fitting (Figure 3, Item 56) from hose assembly (Figure 3, Item 57).

41. Remove hose assembly (Figure 3, Item 57) from vehicle.

42. Disconnect hose fitting (Figure 3, Item 58) from tee connection and hose assembly (Figure 3, Item 60).

43. Remove clamp (Figure 3, Item 59) and fastener from vehicle.

44. Remove hose assembly (Figure 3, Item 60) from vehicle.

45. Disconnect hose fitting (Figure 3, Item 61) from hose assembly (Figure 3, Item 68) and tee connection.

46. Remove capscrew (Figure 3, Item 62), nut (Figure 3, Item 63), lockwasher (Figure 3, Item 64), washer (Figure 3, Item 65), and clamp (Figure 3, Item 66) from vehicle. Discard lockwasher.

47. Disconnect tube fitting (Figure 3, Item 67) from hose assembly (Figure 3, Item 68) and tube assembly (Figure 3, Item 75).

48. Remove hose assembly (Figure 3, Item 68) from vehicle.

49. Remove capscrew (Figure 3, Item 69), nut (Figure 3, Item 70), lockwasher (Figure 3, Item 71), washer (Figure 3, Item 72), and clamp (Figure 3, Item 73) from vehicle. Discard lockwasher.



**REMOVAL - CONTINUED**

- 50. Disconnect tube fitting (Figure 3, Item 74) from tube assembly (Figure 3, Item 75) and oil filter assembly.
- 51. Remove tube assembly (Figure 3, Item 75) from vehicle.

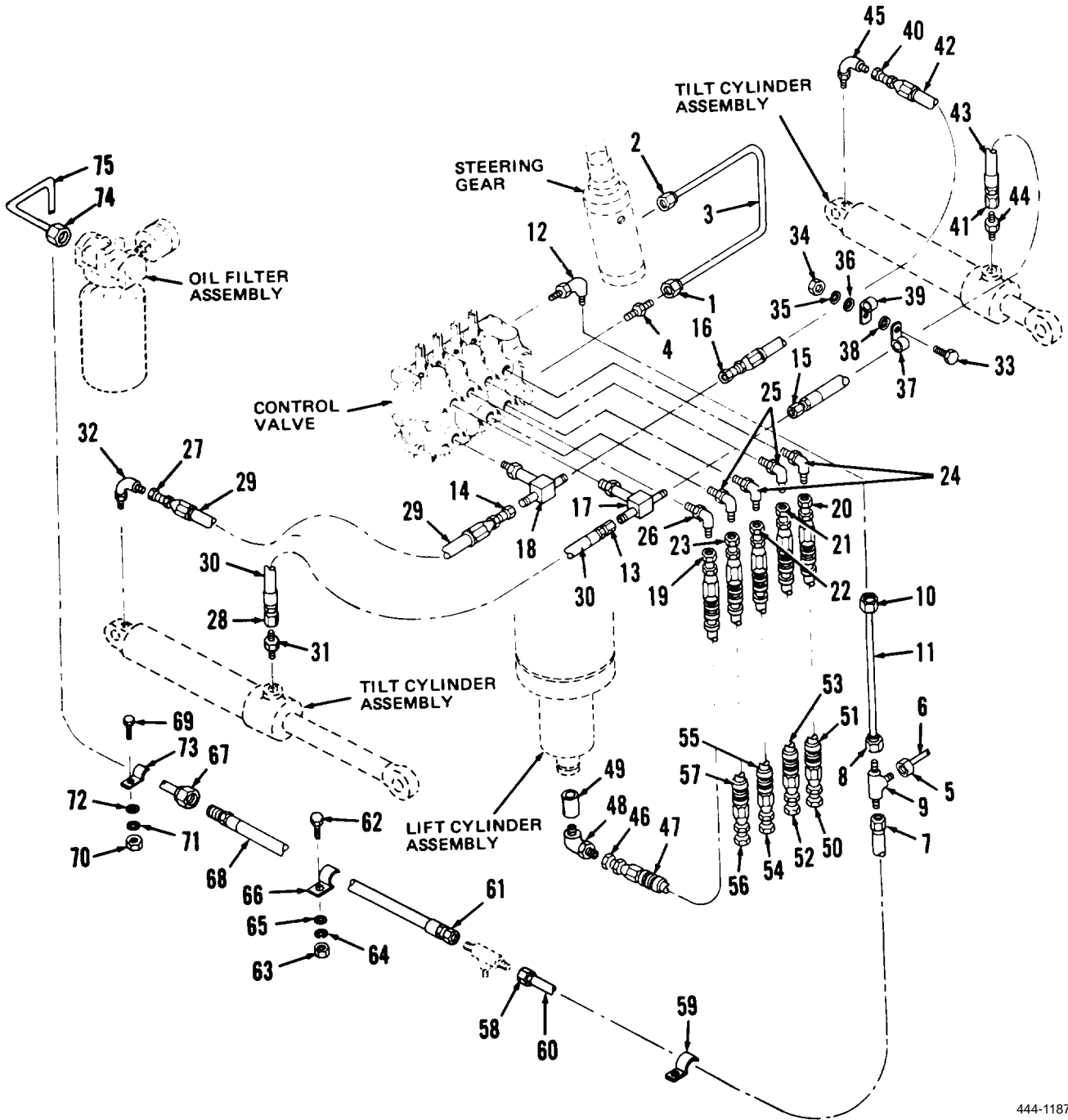

Figure 3. Hydraulic Hoses, Lines, and Fittings.

444-1187

**END OF TASK**

**CLEANING****WARNING**

Solvent cleaning compound MIL-PRF-680 Type III is an environmentally compliant and low toxic material. However, it may be irritating to the eyes and skin. Use protective gloves and goggles. Use in well-ventilated areas. Keep away from open flames and other sources of ignition. Failure to do so may result in injury or death to personnel.

Use solvent cleaning compound to clean all parts.

**END OF TASK****INSPECTION**

1. Inspect tube assemblies. Replace if cracked, kinked, dented, twisted, or fitting threads damaged.
2. Inspect connector, tees, adapters, and elbows. Replace if cracked, distorted, or threads damaged.
3. Inspect hose assemblies. Replace if cracked, split, or fitting threads damaged.
4. Inspect clamps. Replace if bent or cracked.
5. Inspect restrictor. Replace if cracked, damaged, or threads damaged.

**END OF TASK****INSTALLATION/REPLACEMENT****NOTE**

Remove plugs/caps from tube and hose assemblies and cylinders as connections are made.

1. Position tube assembly (Figure 4, Item 75) between oil filter head and front of rear chassis.
2. Connect tube fitting (Figure 4, Item 74) to oil filter head and tighten.
3. Position clamp (Figure 4, Item 73) on tube assembly (Figure 4, Item 75) and install capscrew (Figure 4, Item 69), washer (Figure 4, Item 72), new lockwasher (Figure 4, Item 71), and nut (Figure 4, Item 70). Tighten nut.
4. Position hose assembly (Figure 4, Item 68) between tube assembly (Figure 4, Item 75) and tee located on relief valve.
5. Connect tube fitting (Figure 4, Item 67) to hose (Figure 4, Item 68) and tighten.
6. Position clamp (Figure 4, Item 66) on hose assembly (Figure 4, Item 68). Install capscrew (Figure 4, Item 62), washer (Figure 4, Item 65), new lockwasher (Figure 4, Item 64), and nut (Figure 4, Item 63). Tighten nut.
7. Connect hose fitting (Figure 4, Item 61) to hose (Figure 4, Item 68) and tee connection.
8. Connect hose fitting (Figure 4, Item 58) to hose assembly (Figure 4, Item 60) and position both between tee located on relief valve and operator's compartment.
9. Position clamp (Figure 4, Item 59) on hose (Figure 4, Item 60) and secure to right side of accelerator pivot base.
10. Connect hose fitting (Figure 4, Item 58) to tee located on relief valve. Tighten hose fitting.
11. Position hose assembly (Figure 4, Item 57) on vehicle and connect to hose fitting (Figure 4, Item 56).
12. Connect hose fitting (Figure 4, Item 56) to fitting on left outer mast. Tighten hose fitting.
13. Position hose assembly (Figure 4, Item 55) on vehicle and connect to hose fitting (Figure 4, Item 54).
14. Connect hose fitting (Figure 4, Item 54) to fitting on outer mast, center mounting bracket, right side. Tighten hose fitting.

**INSTALLATION/REPLACEMENT - CONTINUED**

15. Position hose assembly (Figure 4, Item 53) on vehicle and connect to hose fitting (Figure 4, Item 52).
16. Connect hose fitting (Figure 4, Item 52) to fitting on outer mast, right side. Tighten hose fitting.
17. Position hose assembly (Figure 4, Item 51) on vehicle and connect to hose fitting (Figure 4, Item 50).
18. Connect hose fitting (Figure 4, Item 50) to fitting on outer mast, center mounting bracket, left side. Tighten hose fitting.

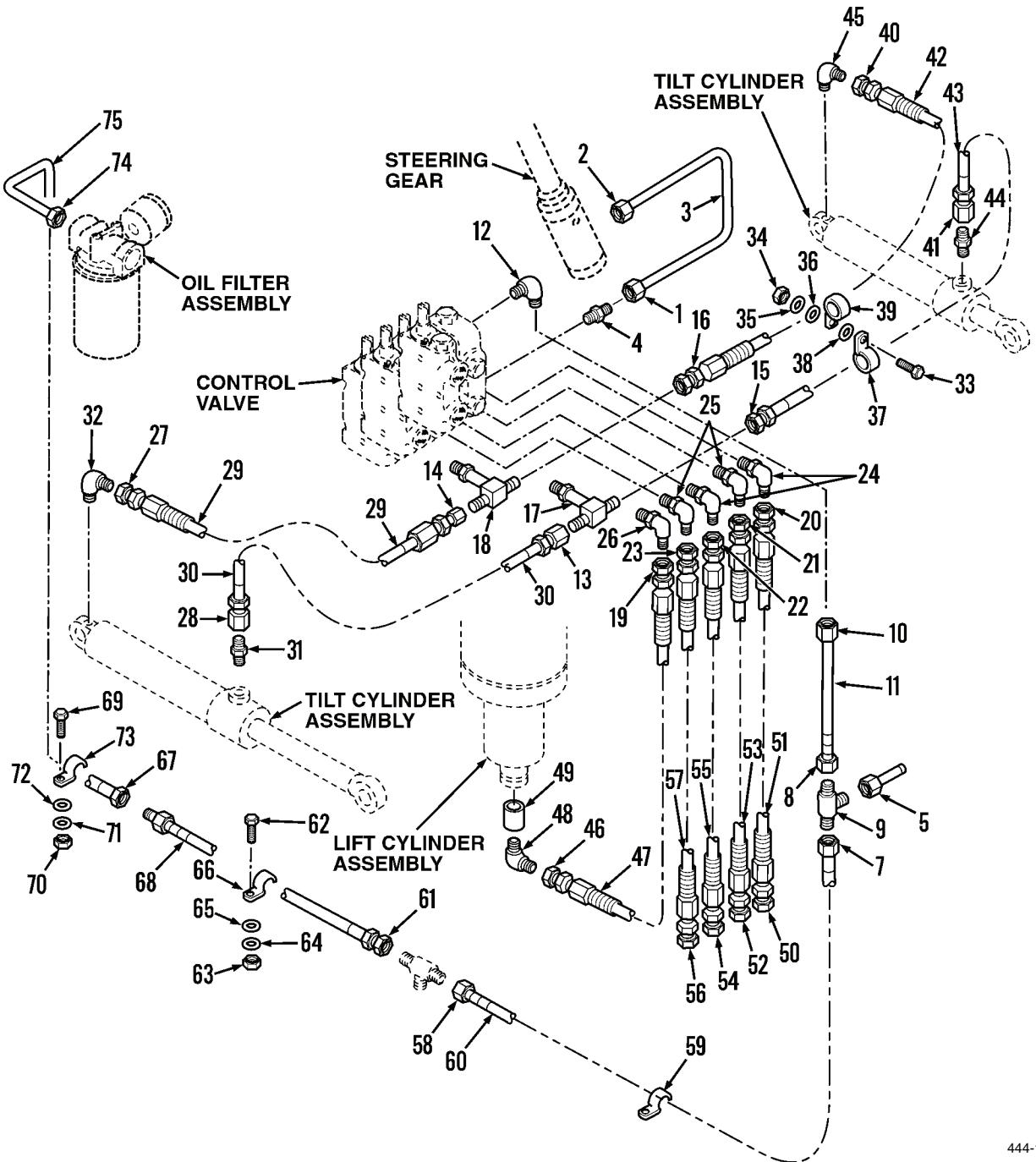

444-1187

**Figure 4. Hydraulic Hoses, Lines, and Fittings.**

**INSTALLATION/REPLACEMENT - CONTINUED**

19. Install restrictor (Figure 5, Item 49) in lift cylinder port.
20. Install elbow (Figure 5, Item 48) on restrictor (Figure 5, Item 49) and lift cylinder port.
21. Position hose assembly (Figure 5, Item 47) on vehicle and connect to hose fitting (Figure 5, Item 46).
22. Connect hose fitting (Figure 5, Item 46) to elbow (Figure 5, Item 48) and tighten.
23. Install elbow (Figure 5, Item 45) on left tilt cylinder assembly.
24. Install adapter (Figure 5, Item 44) on left tilt cylinder assembly.
25. Position hose assembly (Figure 5, Item 43) between cylinder and control valve.
26. Connect hose fitting (Figure 5, Item 41) to adapter (Figure 5, Item 44) and tighten.
27. Position hose assembly (Figure 5, Item 42) between cylinder and control valve.
28. Connect hose fitting (Figure 5, Item 40) to elbow (Figure 5, Item 45) and tighten.
29. Position clamp (Figure 5, Item 39) on hose (Figure 5, Item 42).
30. Position clamp (Figure 5, Item 37) on hose (Figure 5, Item 43) and place on capscrew (Figure 5, Item 33).
31. Install spacer (Figure 5, Item 38), clamp (Figure 5, Item 39), washer (Figure 5, Item 36), new lockwasher (Figure 5, Item 35), and nut (Figure 5, Item 34) on capscrew (Figure 5, Item 33). Tighten nut.
32. Install elbow (Figure 5, Item 32) and adapter (Figure 5, Item 31) on right tilt cylinder assembly.
33. Position hose assembly (Figure 5, Item 30) between cylinder and control valve.
34. Connect hose fitting (Figure 5, Item 28) to adapter (Figure 5, Item 31) and tighten.
35. Connect hose assembly (Figure 5, Item 30) to hose fitting (Figure 5, Item 28).
36. Position hose assembly (Figure 5, Item 29) between cylinder and control valve.
37. Connect hose fitting (Figure 5, Item 27) to elbow (Figure 5, Item 32) and tighten.
38. Connect hose assembly (Figure 5, Item 29) to hose fitting (Figure 5, Item 27).
39. Install elbow (Figure 5, Item 26) on control valve.
40. Install elbows (Figure 5, Item 25 and 24) on control valve.

**NOTE**

Elbows (Figure 5, Items 24, 25, and 26) are adjustable; if necessary, loosen nut (part of elbow) and extend or compress elbow as required to install it. After installation, be sure to tighten elbow nut to prevent hydraulic oil leakage.

41. Connect hose fittings (Figure 5, Items 22 and 23) to elbows (Figure 5, Items 25 and 24) and tighten.
42. Connect hose fittings (Figure 5, Items 20 and 21) to hose fittings (Figure 5, Items 22 and 23) and tighten.
43. Connect hose fitting (Figure 5, Item 19) to elbow (Figure 5, Item 26) and tighten.
44. Install tees (Figure 5, Items 17 and 18) on control valve and tighten.
45. Connect hose fittings (Figure 5, Items 15 and 16) to tees (Figure 5, Items 17 and 18) and tighten.
46. Connect hose fittings (Figure 5, Items 13 and 14) to tees (Figure 5, Items 17 and 18) and tighten.
47. Install adapter (Figure 5, Item 12) in control valve.
48. Position tube assembly (Figure 5, Item 11) on adapter (Figure 5, Item 12) and tighten tube fitting (Figure 5, Item 10).
49. Connect tee (Figure 5, Item 9) to fitting (Figure 5, Item 8) and tighten fitting.
50. Connect hose fitting (Figure 5, Item 7) to tee (Figure 5, Item 9) and tighten.
51. Position tube assembly (Figure 5, Item 6) on tee (Figure 5, Item 9) and tighten tube fitting (Figure 5, Item 5).
52. Install connector (Figure 5, Item 4) on control valve.

**INSTALLATION/REPLACEMENT - CONTINUED**

- 53. Position tube assembly (Figure 5, Item 3) between control valve and steering gear and tighten tube fitting (Figure 5, Item 2) on steering gear.
- 54. Tighten tube fitting (Figure 5, Item 1) on connector (Figure 5, Item 4).

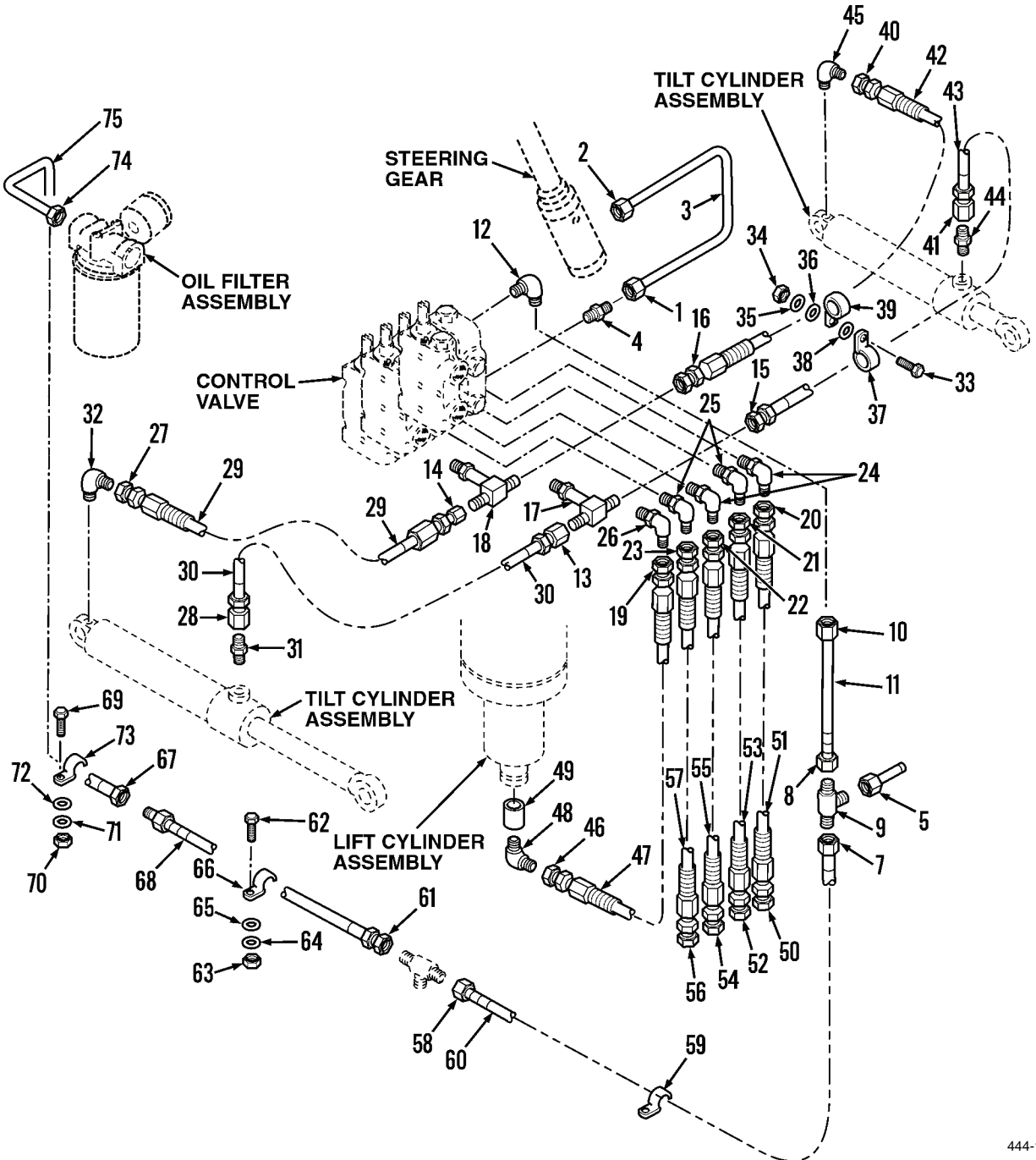

**Figure 5. Hydraulic Hoses, Lines, and Fittings.**

**END OF TASK**

**BLEEDING AIR FROM LIFT CYLINDER**

1. Start engine and operate at idle speed while turning steering wheel to extreme right and left several times.
2. Increase engine speed and operate control valve levers (lift, rotate, shift, and tilt control levers) several times.
3. Operate engine at idle speed and check for oil leaks at connections. Tighten fittings if necessary.
4. Turn engine OFF.
5. Check hydraulic oil reservoir oil level; add oil if necessary (WP 0198).
6. Start engine, operate at idle speed, and operate lift control lever to raise forks 5 ft (152 cm) from ground. Turn engine OFF.

**WARNING**

When performing step 7, do not look directly down at bleed fitting; hydraulic oil is under pressure and may cause injury to personnel.

7. Mount carriage assembly and slowly open bleed fitting located at top of lift cylinder assembly to bleed air; when carriage assembly almost touches ground, close bleed fitting.
8. Repeat steps 5, 6, and 7 until all air is expelled from lift cylinder assembly.

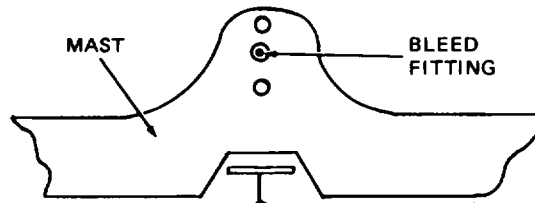

TA127051

**Figure 6. Mast and Bleed Fitting.****END OF TASK****END OF WORK PACKAGE**

---

## ORGANIZATIONAL MAINTENANCE INSTRUCTIONS

### HYDRAULIC HOSES, LINES, AND FITTINGS REPLACEMENT (MAST) SERIAL NO. 9150572 AND BELOW

Removal, Cleaning, Inspection, Installation/Replacement

---

#### INITIAL SETUP

##### Maintenance Level

Organizational

##### Tools and Special Tools

Tool kit, general mechanic's (Item 15, WP 0309)

Shop equipment, common no. 1 (Item 2, WP 0309)

##### Materials/Parts

Cap set, protective (Item 9, WP 0310)

Cleaning compound, solvent (Item 10, WP 0310)

Rag, wiping (Item 26, WP 0310)

Tag, marker (Item 33, WP 0310)

##### References

WP 0193

WP 0195

WP 0198

##### Equipment Condition

Vehicle parked on level surface

Mast tilted forward

Forks resting on ground

Engine OFF

Parking brake applied

All control levers on control valve operated several times to relieve hydraulic pressure

---

---

**REMOVAL****NOTE**

Plug or cap all tube and hose assemblies after removal to prevent entry of dirt/other foreign matter.  
Tag all hose and tube assemblies before removing.

1. Disconnect outer mast hose fitting (WP 0195, *Removal*, step 6).
2. Disconnect four hose fittings (Figure 1, Item 1) from nuts (Figure 1, Item 2).
3. Remove four nuts (Figure 1, Item 2) from elbow fittings (Figure 1, Item 3).
4. Remove four elbow fittings (Figure 1, Item 3) from vehicle.
5. Disconnect four hose fittings (Figure 1, Item 4) from inner mast.
6. Remove four hose assemblies (Figure 1, Item 5) from vehicle.
7. Disconnect four hose fittings (Figure 1, Item 6) from four nuts (Figure 1, Item 9).
8. Disconnect four hose fittings (Figure 1, Item 7) from eight nuts (Figure 1, Item 14).
9. Remove four hose assemblies (Figure 1, Item 8) from inner mast.
10. Remove four nuts (Figure 1, Item 9) from four elbow fittings (Figure 1, Item 10).
11. Remove four elbow fittings (Figure 1, Item 10) from inner mast hose fittings (Figure 1, Item 4).
12. Disconnect four hose fittings (Figure 1, Item 11) from inner mast.
13. Disconnect four hose fittings (Figure 1, Item 12) from nuts (Figure 1, Item 46).



REMOVAL - CONTINUED

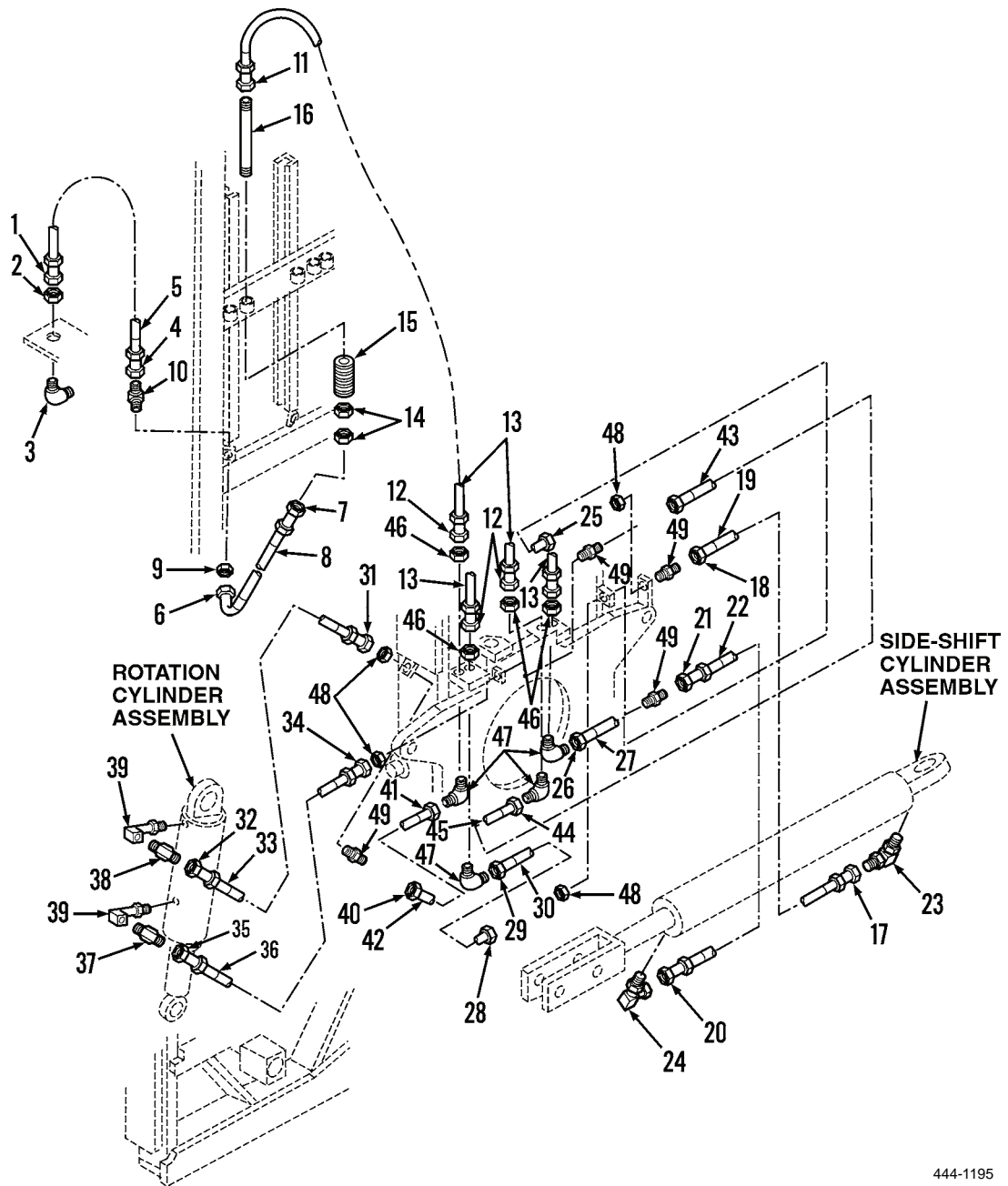
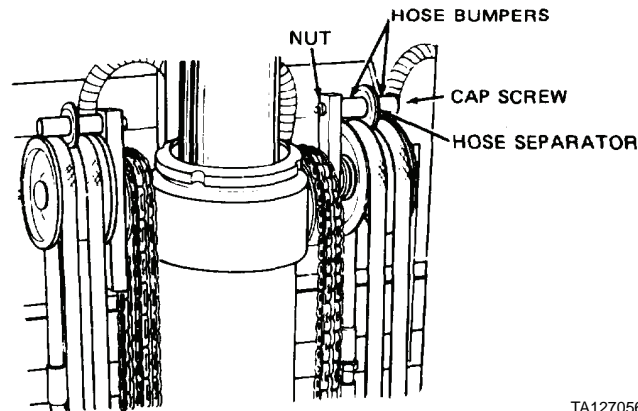

Figure 1. Hydraulic Hoses, Lines, and Fittings.

444-1195

**REMOVAL - CONTINUED**

14. Remove two capscrews and nuts from vehicle (Figure 2) (WP 0193).
15. Remove four hose bumpers from vehicle (Figure 2) (WP 0193).
16. Remove two hose separators (Figure 2) (WP 0193).



TA127056

**Figure 2. Hose Bumpers and Separators.**

17. Remove four hose assemblies (Figure 3, Item 13) from eight nuts (Figure 3, Item 14).
18. Remove eight nuts (Figure 3, Item 14) from four hose springs (Figure 3, Item 15).
19. Remove four hose springs (Figure 3, Item 15) from four tension tubes (Figure 3, Item 16).
20. Remove four tension tubes (Figure 3, Item 16) from four hose fittings (Figure 3, Item 11).
21. Remove four hose assemblies (Figure 3, Item 13) from vehicle.
22. Disconnect hose fittings (Figure 3, Items 17 and 18) from inner mast assembly.
23. Remove hose assembly (Figure 3, Item 19) from vehicle.
24. Disconnect hose fittings (Figure 3, Item 20) from elbow fitting (Figure 3, Item 24).
25. Disconnect hose fitting (Figure 3, Item 21) from fitting (Figure 3, Item 49).
26. Remove hose assembly (Figure 3, Item 22) from vehicle.
27. Remove elbow fittings (Figure 3, Items 23 and 24) from sideshift cylinder assembly.
28. Disconnect tube fittings (Figure 3, Items 25 and 26) from inner mast assembly.
29. Remove tube assembly (Figure 3, Item 27) from vehicle.
30. Disconnect tube fitting (Figure 3, Item 25) from nut (Figure 3, Item 48).
31. Disconnect tube fitting (Figure 3, Item 26) from elbow fitting (Figure 3, Item 47).
32. Disconnect tube fittings (Figure 3, Item 28 and 29) from inner mast assembly.
33. Remove tube assembly (Figure 3, Item 30) from vehicle.
34. Disconnect tube fitting (Figure 3, Item 28) from nut (Figure 3, Item 48).
35. Disconnect tube fitting (Figure 3, Item 29) from elbow fitting (Figure 3, Item 47).
36. Disconnect hose fittings (Figure 3, Items 31 and 32) from inner mast.
37. Remove hose assembly (Figure 3, Item 33) from vehicle.
38. Disconnect hose fitting (Figure 3, Item 31) from 90 degree fitting (Figure 3, Item 38).
39. Disconnect hose fitting (Figure 3, Item 32) from nut (Figure 3, Item 48).
40. Disconnect hose fittings (Figure 3, Item 34 and 35) from inner mast assembly.
41. Remove hose assembly (Figure 3, Item 36) from vehicle.
42. Disconnect hose fitting (Figure 3, Item 34) from nut (Figure 3, Item 48).
43. Disconnect hose fitting (Figure 3, Item 35) from 45 degree fitting (Figure 3, Item 37).

**REMOVAL - CONTINUED**

44. Remove 45 degree fitting (Figure 3, Item 37) from 90 degree fitting (Figure 3, Item 39).
45. Remove 90 degree fitting (Figure 3, Item 38) from 90 degree fitting (Figure 3, Item 39).
46. Remove two 90 degree fittings (Figure 3, Item 39) from rotation cylinder assembly.
47. Disconnect tube fittings (Figure 3, Items 40 and 41) from inner mast assembly.
48. Remove tube assembly (Figure 3, Item 42) from vehicle.
49. Disconnect tube fitting (Figure 3, Item 40) from fitting (Figure 3, Item 49).
50. Disconnect tube fitting (Figure 3, Item 41) from elbow fitting (Figure 3, Item 47).

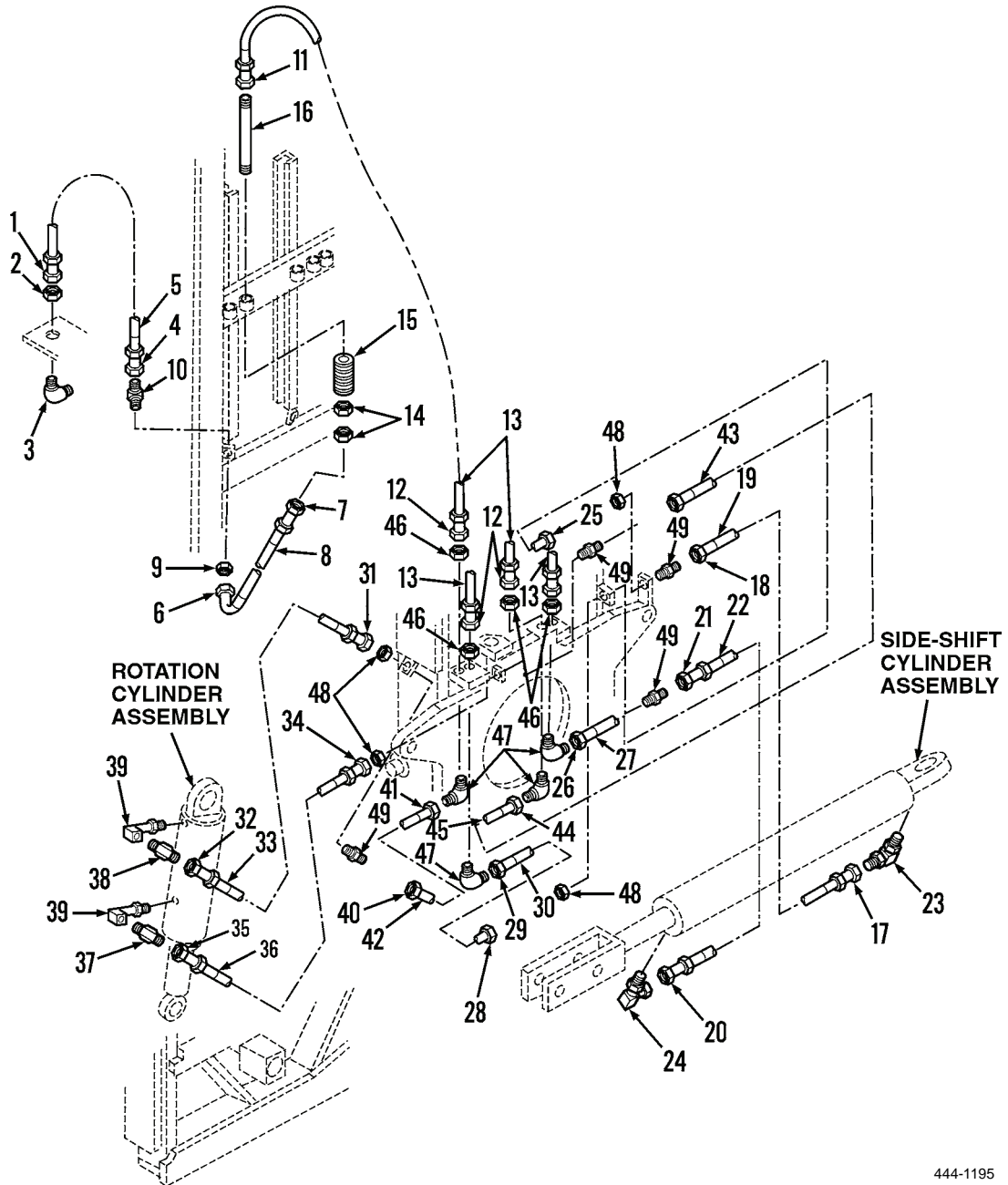

**Figure 3. Hydraulic Hoses, Lines, and Fittings.**

444-1195

**REMOVAL - CONTINUED**

51. Disconnect tube fittings (Figure 4, Items 43 and 44) from inner mast.
52. Remove tube assembly (Figure 4, Item 45) from vehicle.
53. Disconnect tube fitting (Figure 4, Item 43) from fitting (Figure 4, Item 49).
54. Disconnect tube fitting (Figure 4, Item 44) from elbow fitting (Figure 4, Item 47).
55. Remove four nuts (Figure 4, Item 46) from vehicle.
56. Remove four elbow fittings (Figure 4, Item 47) from vehicle.
57. Remove four nuts (Figure 4, Item 48) from vehicle.
58. Remove four fittings (Figure 4, Item 49) from vehicle.

**END OF TASK****CLEANING**

Solvent cleaning compound MIL-PRF-680 Type III is an environmentally compliant and low toxic material. However, it may be irritating to the eyes and skin. Use protective gloves and goggles. Use in well-ventilated areas. Keep away from open flames and other sources of ignition. Failure to do so may result in injury or death to personnel.

Use solvent cleaning compound to clean all parts.

**END OF TASK****INSPECTION**

1. Inspect elbow fittings, 45 degree fitting, 90 degree fittings, and fitting. Replace if cracked, distorted, or threads damaged.
2. Inspect hose assemblies. Replace if cracked, split, or fitting threads damaged.
3. Inspect tube assemblies and tension tubes. Replace if cracked, kinked, dented, twisted, or fitting threads damaged.
4. Inspect hose springs. Replace if cracked or damaged or evidence of permanent set is obvious.

**END OF TASK****INSTALLATION/REPLACEMENT**

1. Position four fittings (Figure 4, Item 49) on carriage assembly.
2. Install four nuts (Figure 4, Item 48) on four fittings (Figure 4, Item 49) and tighten.
3. Position four elbow fittings (Figure 4, Item 47) on carriage assembly.
4. Install four nuts (Figure 4, Item 46) on four elbow fittings (Figure 4, Item 47) and tighten.
5. Position tube assembly (Figure 4, Item 45) on carriage assembly.
6. Connect tube fittings (Figure 4, Items 44 and 43) to elbow fitting (Figure 4, Item 47) and fitting (Figure 4, Item 49), respectively. Tighten tube fittings.
7. Position tube assembly (Figure 4, Item 42) on carriage assembly.

**INSTALLATION/REPLACEMENT - CONTINUED**

8. Connect tube fittings (Figure 4, Items 41 and 40) to elbow fitting (Figure 4, Item 47) and fitting (Figure 4, Item 49), respectively. Tighten tube fittings.
9. Install two 90 degree fittings (Figure 4, Item 39) in rotation cylinder assembly.
10. Install 90 degree fitting (Figure 4, Item 38) on 90 degree fitting (Figure 4, Item 39).
11. Install 45 degree fitting (Figure 4, Item 37) on 90 degree fitting (Figure 4, Item 39).
12. Position hose assembly (Figure 4, Item 36) on carriage assembly.

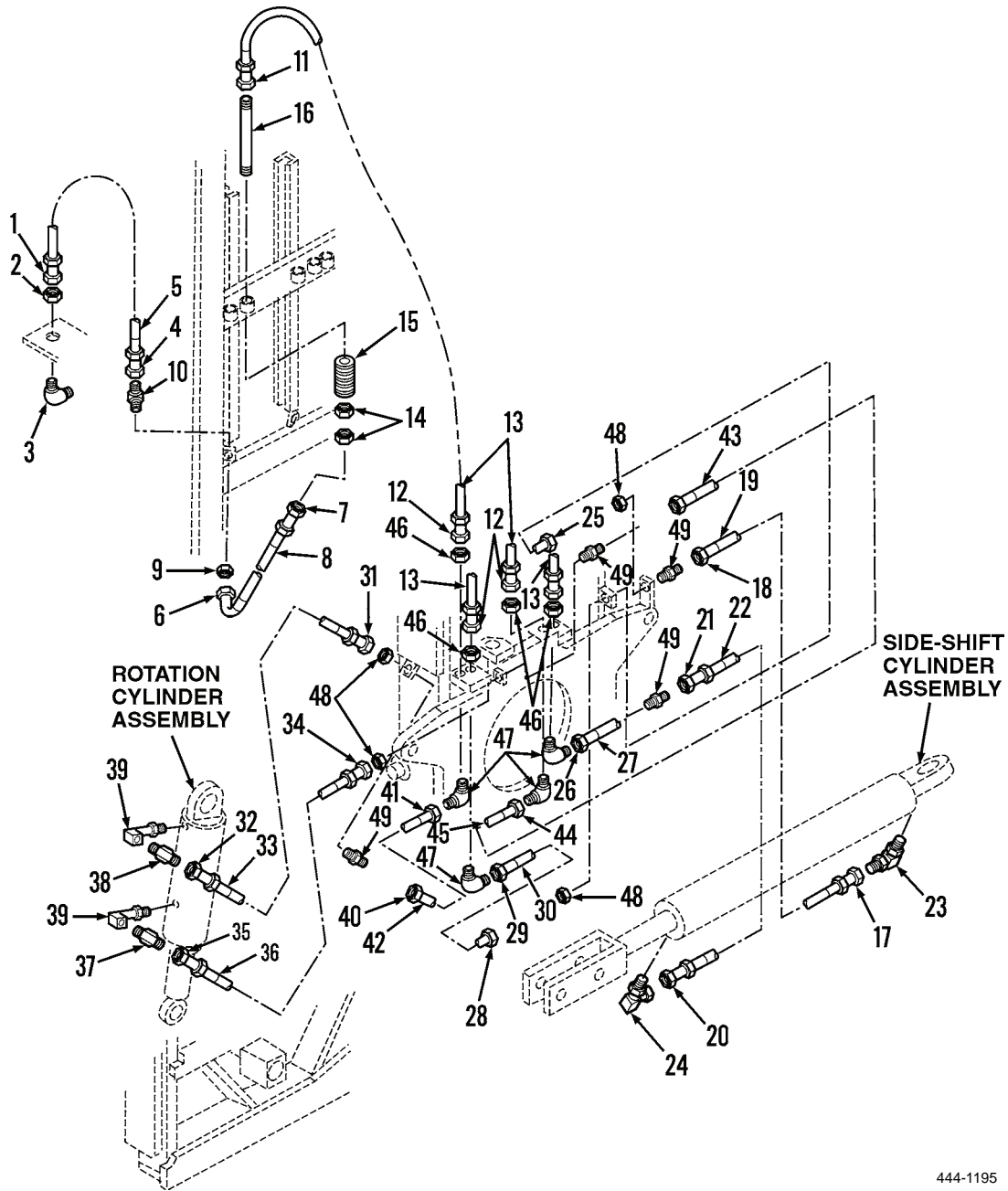
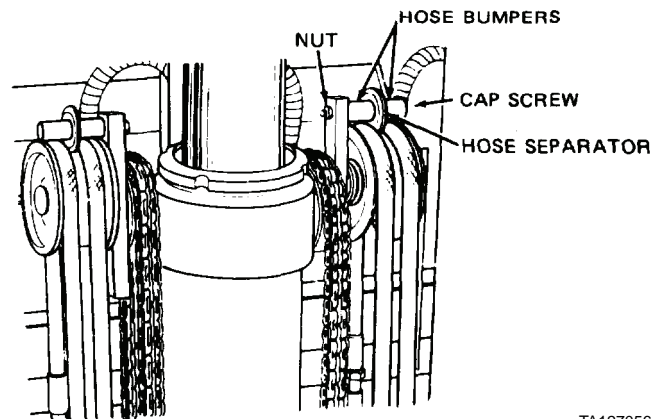

**Figure 4. Hydraulic Hoses, Lines, and Fittings.**

444-1195

**INSTALLATION/REPLACEMENT - CONTINUED**

13. Connect hose fittings (Figure 6, Items 35 and 34) to 45 degree fitting (Figure 6, Item 37) and fitting (Figure 6, Item 49), respectively. Tighten hose fittings.
14. Position hose assembly (Figure 6, Item 33) on carriage assembly.
15. Connect hose fittings (Figure 6, Items 32 and 31) to 90 degree fitting (Figure 6, Item 38) and fitting (Figure 6, Item 49), respectively. Tighten hose fittings.
16. Position tube assembly (Figure 6, Item 30) on carriage assembly.
17. Connect tube fittings (Figure 6, Items 29 and 28) to elbow fitting (Figure 6, Item 47) and fitting (Figure 6, Item 49), respectively. Tighten tube fittings.
18. Position tube assembly (Figure 6, Item 27) on carriage assembly.
19. Connect tube fittings (Figure 6, Items 26 and 25) to elbow fitting (Figure 6, Item 47) and fitting (Figure 6, Item 49), respectively. Tighten tube fittings.
20. Install elbow fittings (Figure 6, Items 24 and 23) on sideshift cylinder assembly.
21. Position hose assembly (Figure 6, Item 22) on carriage assembly.
22. Connect hose fittings (Figure 6, Items 21 and 20) to fitting (Figure 6, Item 49) and elbow fitting (Figure 6, Item 24), respectively. Tighten hose fittings.
23. Position hose assembly (Figure 6, Item 19) on carriage assembly.
24. Connect hose fittings (Figure 6, Items 18 and 17) to fitting (Figure 6, Item 49) and elbow fitting (Figure 6, Item 23), respectively. Tighten hose fittings.
25. Position tension tube (Figure 6, Item 16) on inner mast assembly with short threaded end towards fitting (Figure 6, Item 11).
26. Position four hose springs (Figure 6, Item 15) on tension tubes (Figure 6, Item 16).
27. Install eight nuts (Figure 6, Item 14) on four hose springs (Figure 6, Item 15).
28. Position four hose assemblies (Figure 6, Item 13) on eight nuts (Figure 6, Item 14) on inner mast assembly.



TA127056

**Figure 5. Hose Bumpers and Separators.**

29. Position hose bumper and hose separator on capscrew (Figure 5) (WP 0193).
30. Install two capscrews and nuts. Position four hose assemblies (Figure 6, Item 13) on each side of separator (Figure 5) (WP 0193).
31. Connect four hose fittings (Figure 6, Item 11) to tension tube (Figure 6, Item 16) and tighten.
32. Connect four hose fittings (Figure 6, Item 12) to elbow fitting (Figure 6, Item 47) and tighten.
33. Position elbow fitting (Figure 6, Item 10) and install nut (Figure 6, Item 9).

**INSTALLATION/REPLACEMENT - CONTINUED**

34. Position hose assembly (Figure 6, Item 8) on vehicle and connect hose fittings (Figure 6, Items 7 and 6).
35. Position hose assembly (Figure 6, Item 5) and connect hose fitting (Figure 6, Item 4) and tighten.
36. Connect hose fitting (Figure 6, Item 4) to elbow fitting (Figure 6, Item 10).
37. Position elbow fitting (Figure 6, Item 3) on outer mast assembly and install nut (Figure 6, Item 2).
38. Connect hose fitting (Figure 6, Item 1) to elbow fitting (Figure 6, Item 3) and tighten.
39. Connect and tighten hose fitting (WP 0195, *Installation/Replacement*, steps 11 through 18).

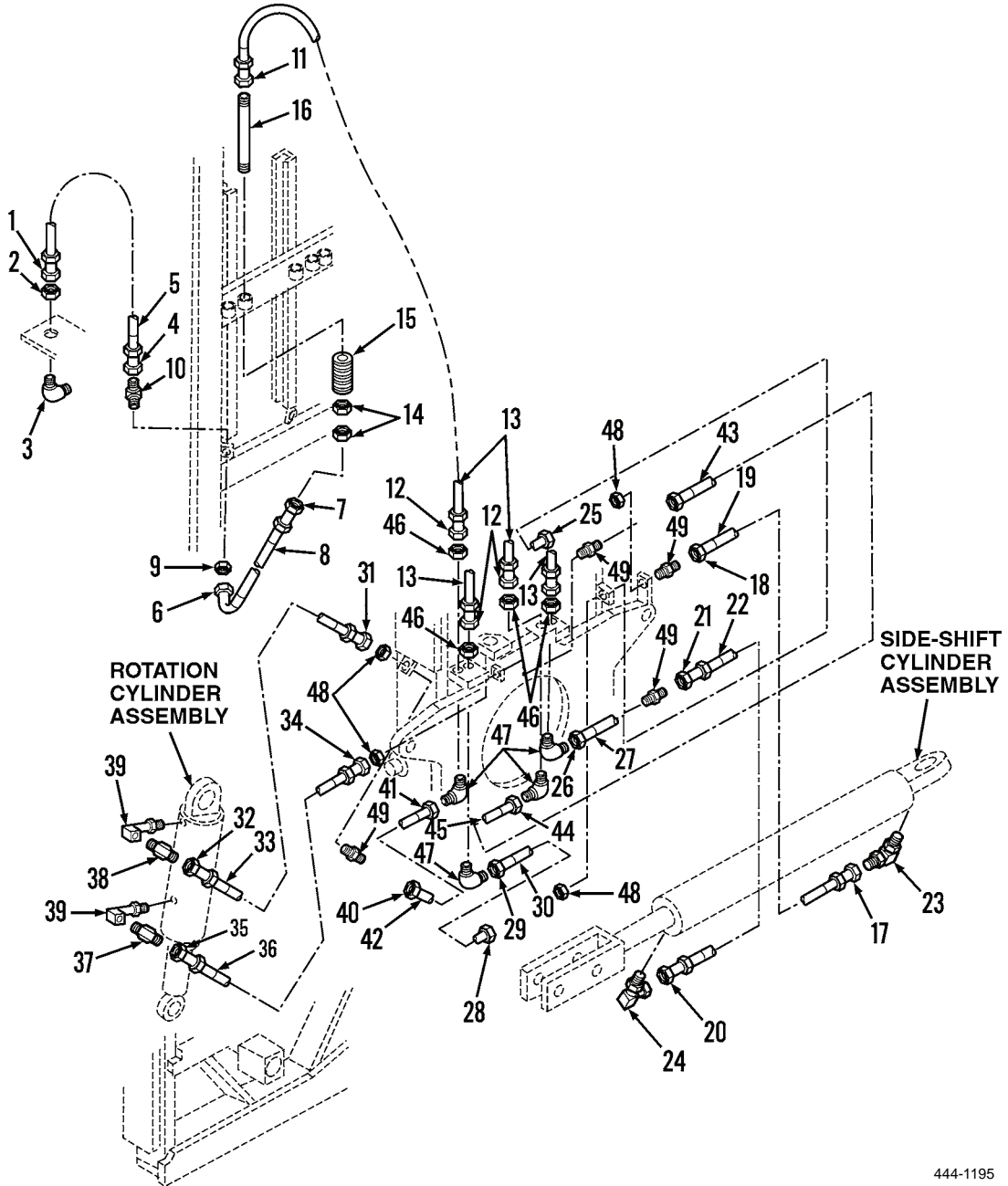

**Figure 6. Hydraulic Hoses, Lines, and Fittings.**

444-1195

**INSTALLATION/REPLACEMENT - CONTINUED**

40. Start engine and operate at idle speed while turning steering wheel to extreme right and left several times.
41. Increase engine speed and operate control valve levers (lift, rotate, shift, and tilt control levers) several times.
42. Operate engine at idle speed and check for oil leaks at connections. Tighten fittings if necessary.
43. Turn engine OFF.
44. Check hydraulic reservoir oil level; add oil if necessary (WP 0198).
45. Repeat steps 40 through 44.

**END OF TASK****END OF WORK PACKAGE**



---

## ORGANIZATIONAL MAINTENANCE INSTRUCTIONS

### HYDRAULIC HOSES, LINES, AND FITTINGS REPLACEMENT (MAST) SERIAL NO. 9150573 AND ABOVE

Removal, Cleaning, Inspection, Installation/Replacement

---

#### INITIAL SETUP

##### Maintenance Level

Organizational

##### Tools and Special Tools

Tool kit, general mechanic's (Item 15, WP 0309)

Shop equipment, common no. 1 (Item 2, WP 0309)

##### Materials/Parts

Cap set, protective (Item 9, WP 0310)

Cleaning compound, solvent (Item 10, WP 0310)

Rag, wiping (Item 26, WP 0310)

Tag, marker (Item 33, WP 0310)

Lockwasher (2)

##### References

WP 0193

WP 0198

##### Equipment Condition

Vehicle parked on level surface

Mast tilted forward

Forks resting on ground

Mast vertical

Engine OFF

Parking brake applied

All control levers on control valve operated several times to relieve hydraulic pressure

---

**REMOVAL****WARNING**

Hydraulic system is under pressure. Before disconnecting any hoses, lines, or fittings, operate all hydraulic control levers to relieve hydraulic system pressure. Failure to do so could cause injury or death to personnel.

**NOTE**

Plug or cap all tube and hose assemblies after removal to prevent entry of dirt or other foreign matter. Tag all hose and tube assemblies before removing.

1. Disconnect four tube fittings (Figure 1, Item 1) from four control valve hoses in outer mast assembly.
2. Disconnect four tube fittings (Figure 1, Item 2) from two hoses (Figure 1, Items 2D and 2E).
3. Remove two capscrews (Figure 1, Item 2A), lockwashers (Figure 1, Item 2B), and clamps (Figure 1, Item 2C) from outer mast assembly. Discard lockwashers.
4. Remove two tube assemblies (Figure 1, Item 2D and 2E) from vehicle.
5. Disconnect four hose fittings (Figure 1, Item 3) from four fittings (Figure 1, Item 3B).
6. Remove four nuts (Figure 1, Item 3A) from four fittings (Figure 1, Item 3B).
7. Remove four fittings (Figure 1, Item 3B) from outer mast assembly.
8. Disconnect four hose fittings (Figure 1, Item 4) from inner mast assembly.
9. Remove four hose assemblies (Figure 1, Item 5) from vehicle.
10. Disconnect four hose fittings (Figure 1, Item 6) from inner mast assembly.
11. Disconnect four hose fittings (Figure 1, Item 7) from nuts (Figure 1, Item 14).
12. Remove four hose assemblies (Figure 1, Item 8) from vehicle.
13. Remove four nuts (Figure 1, Item 9) from elbow fittings (Figure 1, Item 10).
14. Remove four elbow fittings (Figure 1, Item 10) from hose fittings (Figure 1, Item 4).
15. Disconnect four hose fittings (Figure 1, Item 11) from tension tubes (Figure 1, Item 16).
16. Disconnect four hose fittings (Figure 1, Item 12) from nuts (Figure 1, Item 46).

REMOVAL - CONTINUED

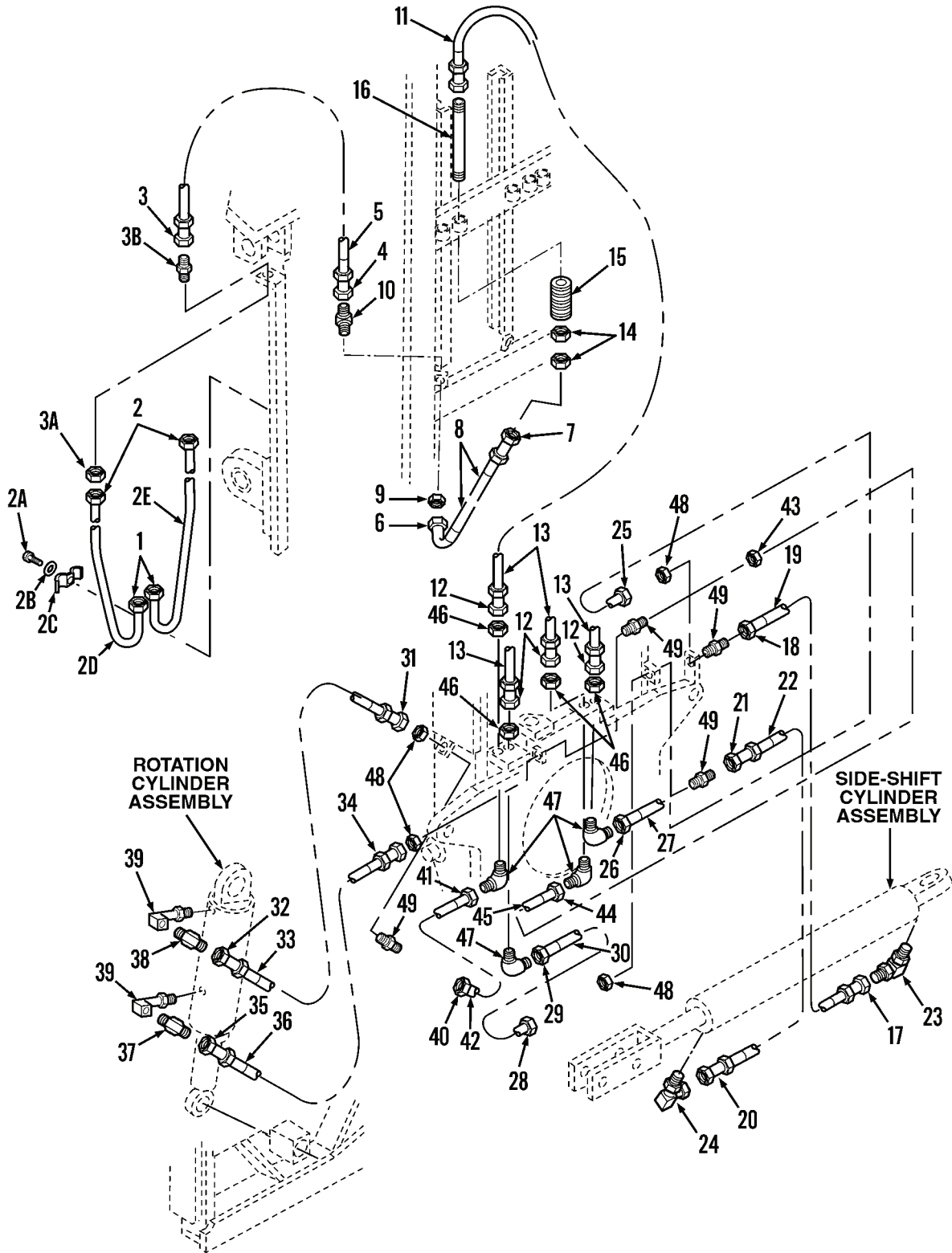
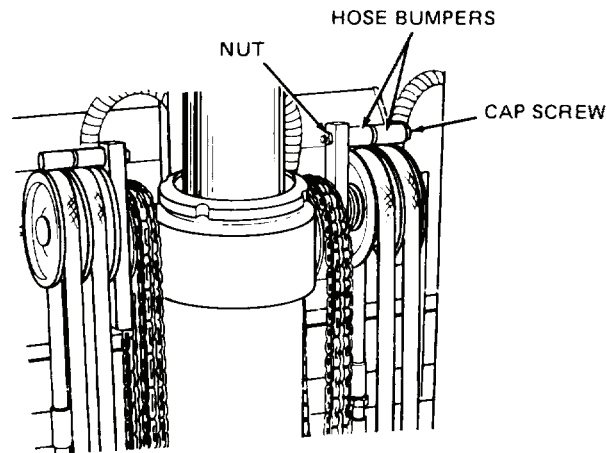

Figure 1. Hydraulic Hoses, Lines, and Fittings.

444-1203

**REMOVAL - CONTINUED**

17. Remove two capscrews and nuts from four hose bumpers (Figure 2) (WP 0193).
18. Remove four hose bumpers from vehicle (Figure 2) (WP 0193).



TA301532

**Figure 2. Hose Bumpers.**

19. Remove four hose assemblies (Figure 3, Item 13) from vehicle.
20. Remove eight nuts (Figure 3, Item 14) from vehicle.
21. Remove four hose springs (Figure 3, Item 15) from vehicle.
22. Remove four tension tubes (Figure 3, Item 16) from vehicle.
23. Disconnect hose fittings (Figure 3, Items 17 and 18) from fitting (Figure 3, Item 49) and elbow fitting (Figure 3, Item 23), respectively.
24. Remove hose assembly (Figure 3, Item 19) from vehicle.
25. Disconnect hose fittings (Figure 3, Items 20 and 21) from fitting (Figure 3, Item 49) and elbow fitting (Figure 3, Item 24), respectively.
26. Remove hose assembly (Figure 3, Item 22) from vehicle.
27. Remove elbow fittings (Figure 3, Items 23 and 24) from sideshift cylinder assembly.
28. Disconnect tube fittings (Figure 3, Items 25 and 26) from nut (Figure 3, Item 48) and elbow fitting (Figure 3, Item 47), respectively.
29. Remove tube assembly (Figure 3, Item 27) from vehicle.
30. Disconnect tube fittings (Figure 3, Items 28 and 29) from nut (Figure 3, Item 48) and elbow fitting (Figure 3, Item 47), respectively.
31. Remove tube assembly (Figure 3, Item 30) from vehicle.
32. Disconnect hose fittings (Figure 3, Items 31 and 32) from nut (Figure 3, Item 48) and 90 degree fitting (Figure 3, Item 38), respectively.
33. Remove hose assembly (Figure 3, Item 33) from vehicle.
34. Disconnect hose fittings (Figure 3, Items 34 and 35) from nut (Figure 3, Item 48) and 45 degree fitting (Figure 3, Item 37), respectively.
35. Remove hose assembly (Figure 3, Item 36) from vehicle.
36. Remove 45 degree fitting (Figure 3, Item 37) from bottom 90 degree fitting (Figure 3, Item 39).
37. Remove 90 degree fitting (Figure 3, Item 38) from top 90 degree fitting (Figure 3, Item 39).

REMOVAL - CONTINUED

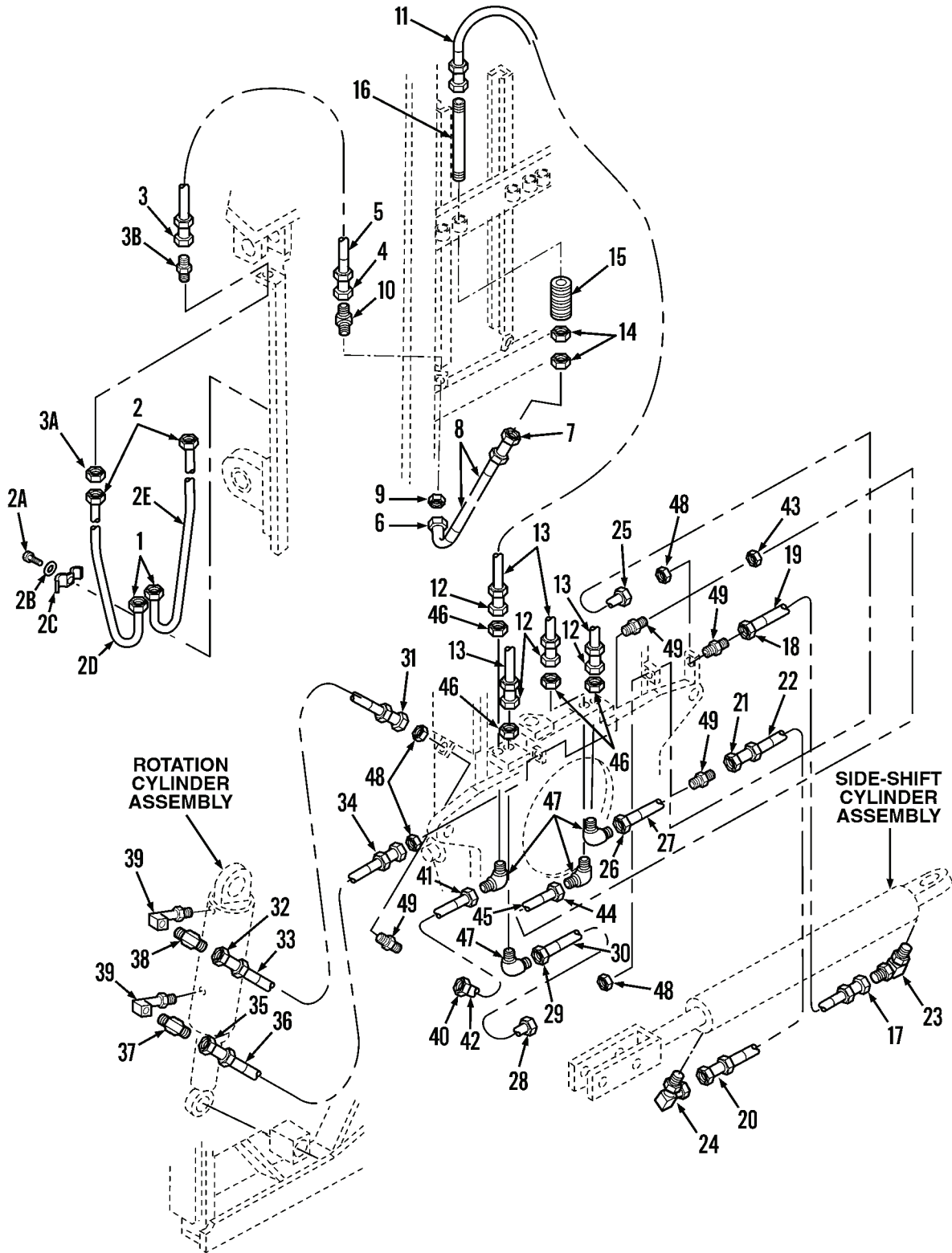

Figure 3. Hydraulic Hoses, Lines, and Fittings.

444-1203

**REMOVAL - CONTINUED**

38. Remove two 90 degree fittings (Figure 4, Item 39) from rotation cylinder assembly.
39. Disconnect tube fittings (Figure 4, Items 40 and 41) from fitting (Figure 4, Item 49) and elbow fitting (Figure 4, Item 47), respectively.
40. Remove tube assembly (Figure 4, Item 42) from vehicle.
41. Disconnect tube fittings (Figure 4, Items 43 and 44) from fitting (Figure 4, Item 49) and elbow fitting (Figure 4, Item 47), respectively.
42. Remove tube assembly (Figure 4, Item 45) from vehicle.
43. Remove four nuts (Figure 4, Item 46) from vehicle.
44. Remove four elbow fittings (Figure 4, Item 47) from vehicle.
45. Remove four nuts (Figure 4, Item 48) from vehicle.
46. Remove four fittings (Figure 4, Item 49) from vehicle.

**END OF TASK****CLEANING****WARNING**

Solvent cleaning compound MIL-PRF-680 Type III is an environmentally compliant and low toxic material. However, it may be irritating to the eyes and skin. Use protective gloves and goggles. Use in well-ventilated areas. Keep away from open flames and other sources of ignition. Failure to do so may result in injury or death to personnel.

Use solvent cleaning compound to clean all parts.

**END OF TASK****INSPECTION**

1. Inspect elbow fittings, 45 degree fitting, 90 degree fittings, and fittings. Replace if cracked, distorted, or threads damaged.
2. Inspect hose assemblies. Replace if cracked, split, or fitting threads damaged.
3. Inspect tube assemblies and tension tubes. Replace if cracked, kinked, dented, twisted, or fitting threads damaged.
4. Inspect hose springs. Replace if cracked or damaged or evidence of permanent set is obvious.

**END OF TASK****INSTALLATION/REPLACEMENT**

1. Position four fittings (Figure 4, Item 49) on carriage assembly.
2. Install four nuts (Figure 4, Item 48) to secure fittings (Figure 4, Item 49).
3. Position four elbow fittings (Figure 4, Item 47) on carriage assembly.
4. Install four nuts (Figure 4, Item 46) to secure elbow fittings (Figure 4, Item 47).
5. Position tube assembly (Figure 4, Item 45) on carriage assembly.

INSTALLATION/REPLACEMENT - CONTINUED

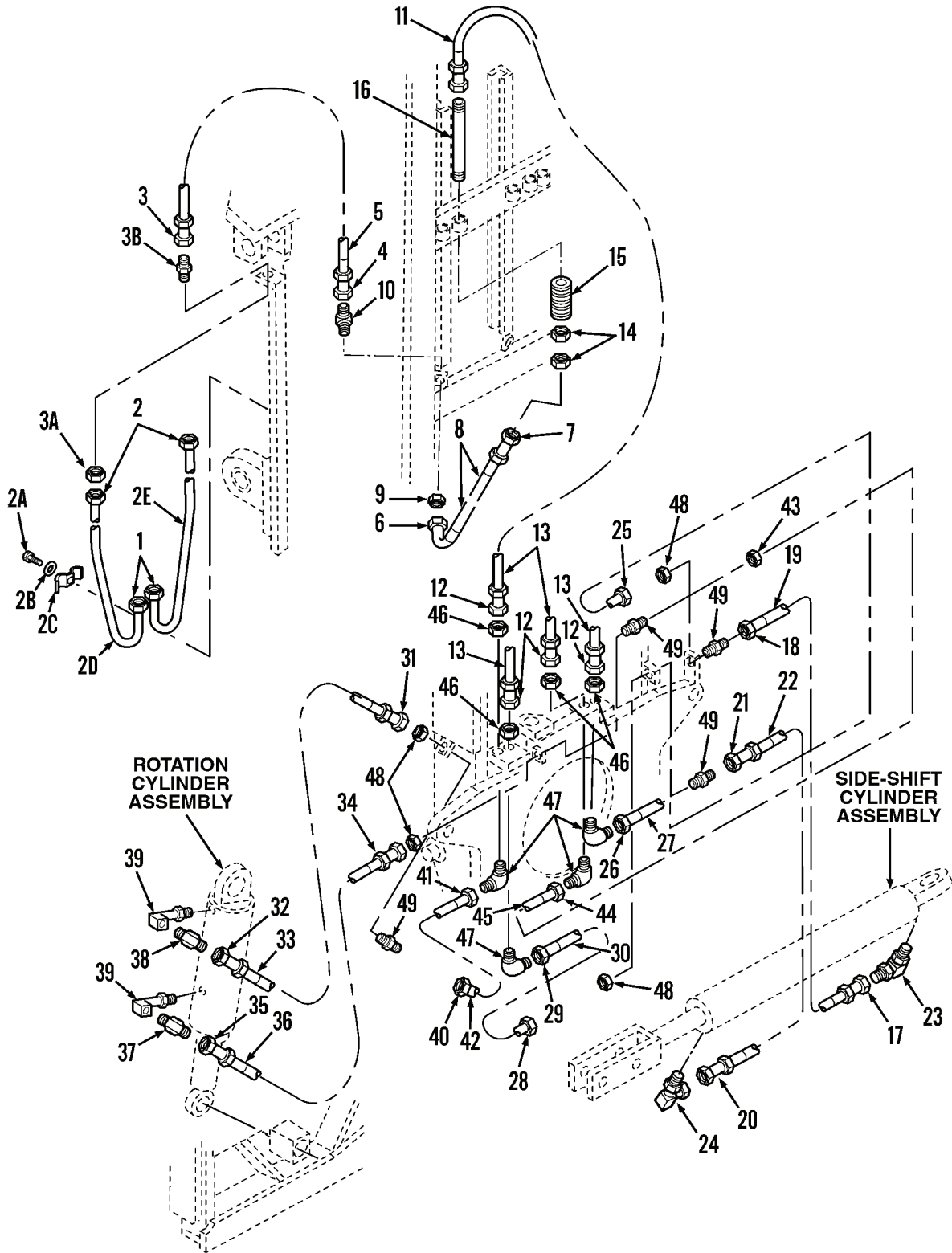

Figure 4. Hydraulic Hoses, Lines, and Fittings.

444-1203

**INSTALLATION/REPLACEMENT - CONTINUED**

6. Connect tube fittings (Figure 5, Items 43 and 44) to fitting (Figure 5, Item 49) and elbow fitting (Figure 5, Item 47), respectively. Tighten tube fittings.
7. Position tube assembly (Figure 5, Item 42) on carriage assembly.
8. Connect tube fittings (Figure 5, Items 40 and 41) to fitting (Figure 5, Item 49) and elbow fitting (Figure 5, Item 47), respectively. Tighten tube fittings.
9. Install two 90 degree fittings (Figure 5, Item 39) on rotation cylinder assembly.
10. Install 90 degree fitting (Figure 5, Item 38) on top 90 degree fitting (Figure 5, Item 39).
11. Install 45 degree fitting (Figure 5, Item 37) on bottom 90 degree fitting (Figure 5, Item 39).
12. Position hose assembly (Figure 5, Item 36) on carriage assembly.
13. Connect hose fittings (Figure 5, Items 34 and 35) to fitting (Figure 5, Item 49) and 45 degree fitting (Figure 5, Item 37), respectively. Tighten hose fittings.
14. Position hose assembly (Figure 5, Item 33) on carriage assembly.
15. Connect hose fittings (Figure 5, Items 31 and 32) to fitting (Figure 5, Item 49) and 90 degree fitting (Figure 5, Item 38), respectively. Tighten hose fittings.
16. Position tube assembly (Figure 5, Item 30) on carriage assembly.
17. Connect tube fittings (Figure 5, Items 28 and 29) to fitting (Figure 5, Item 49) and elbow fitting (Figure 5, Item 47), respectively. Tighten tube fittings.
18. Position tube assembly (Figure 5, Item 27) on carriage assembly.
19. Connect tube fittings (Figure 5, Items 25 and 26) to fitting (Figure 5, Item 49) and elbow fitting (Figure 5, Item 47), respectively. Tighten tube fittings.
20. Install elbow fittings (Figure 5, Items 23 and 24) on sideshift cylinder assembly.
21. Position hose assembly (Figure 5, Item 22) on carriage assembly.
22. Connect hose fittings (Figure 5, Items 20 and 21) to elbow fitting (Figure 5, Item 24) and fitting (Figure 5, Item 49), respectively. Tighten hose fittings.
23. Position hose assembly (Figure 5, Item 19) on carriage assembly.
24. Connect hose assemblies (Figure 5, Items 17 and 18) to elbow fitting (Figure 5, Item 23) and fitting (Figure 5, Item 49), respectively. Tighten hose assemblies.
25. Position tension tube (Figure 5, Item 16) on inner mast assembly with short threaded end towards hose fitting (Figure 5, Item 11).
26. Position hose spring (Figure 5, Item 15) on tension tube (Figure 5, Item 16).
27. Install two nuts (Figure 5, Item 14) on tension tube (Figure 5, Item 16).
28. Position hose assembly (Figure 5, Item 13) on inner mast assembly.



INSTALLATION/REPLACEMENT - CONTINUED

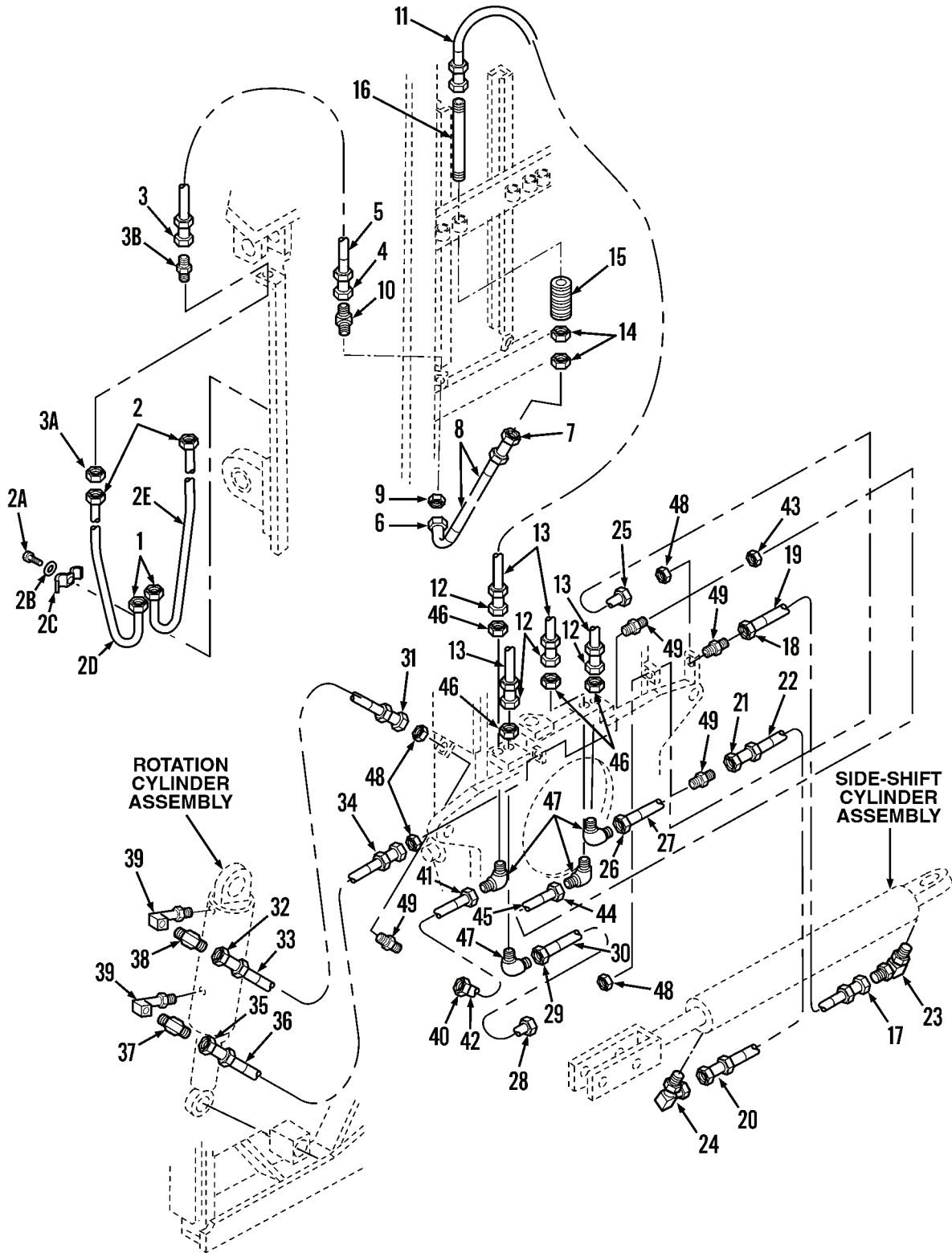
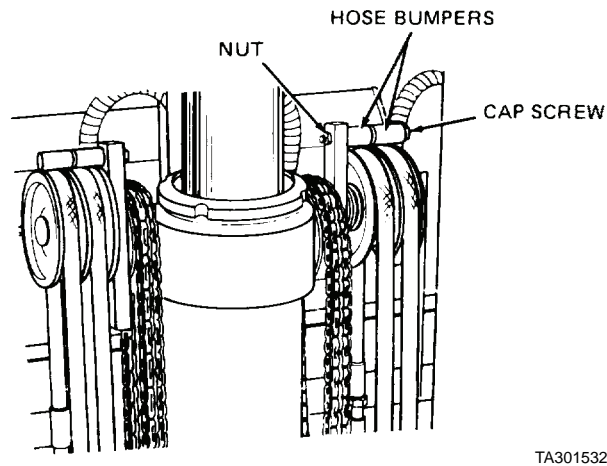

Figure 5. Hydraulic Hoses, Lines, and Fittings.

444-1203

**INSTALLATION/REPLACEMENT - CONTINUED**

29. Position hose bumper on capscrew (Figure 6) (WP 0193).
30. Install capscrew and nut and position hose assemblies (Figure 7, Item 13) in each pulley groove (Figure 6) (WP 0193).

**Figure 6. Hose Bumpers.**

31. Connect hose fitting (Figure 7, Item 11) to tension tube (Figure 7, Item 16) and tighten.
32. Connect hose fitting (Figure 7, Item 12) to elbow fitting (Figure 7, Item 47) and tighten.
33. Position elbow fitting (Figure 7, Item 10) and install nut (Figure 7, Item 9).
34. Position hose assembly (Figure 7, Item 8) on inner mast assembly.
35. Connect hose fittings (Figure 7, Items 6 and 7) to fitting (Figure 7, Item 10) and tension tube (Figure 7, Item 16), respectively. Tighten hose fittings.
36. Position hose assembly (Figure 7, Item 5) on inner mast assembly.
37. Connect hose fitting (Figure 7, Item 4) to elbow fitting (Figure 7, Item 10) and tighten.
38. Install four fittings (Figure 7, Item 3B) on outer mast assembly.
39. Install four nuts (Figure 7, Item 3A) on fittings (Figure 7, Item 3B) and tighten.
40. Connect four hose fittings (Figure 7, Item 3) to fittings (Figure 7, Item 3B) and tighten.
41. Position two tube assemblies (Figure 7, Items 2E and 2D) on outer mast.
42. Install two clamps (Figure 7, Item 2C), new lockwashers (Figure 7, Item 2B), and capscrews (Figure 7, Item 2A) to secure tube assemblies (Figure 7, Items 2E and 2D). Tighten capscrews.
43. Connect four tube fittings (Figure 7, Item 2) to fittings (Figure 7, Item 3B) and tighten.
44. Connect four tube fittings (Figure 7, Item 1) to control valve hoses and tighten.
45. Start engine and operate at idle speed while turning steering wheel to extreme right and left several times.
46. Increase engine speed and operate control valve levers (lift, rotate, shift, and tilt control levers) several times.
47. Operate engine at idle speed and check for oil leaks at connections. Tighten fittings if necessary.
48. Turn engine OFF.
49. Check hydraulic reservoir oil level; add oil if necessary (WP 0198).
50. Repeat steps 45 through 49.

INSTALLATION/REPLACEMENT - CONTINUED

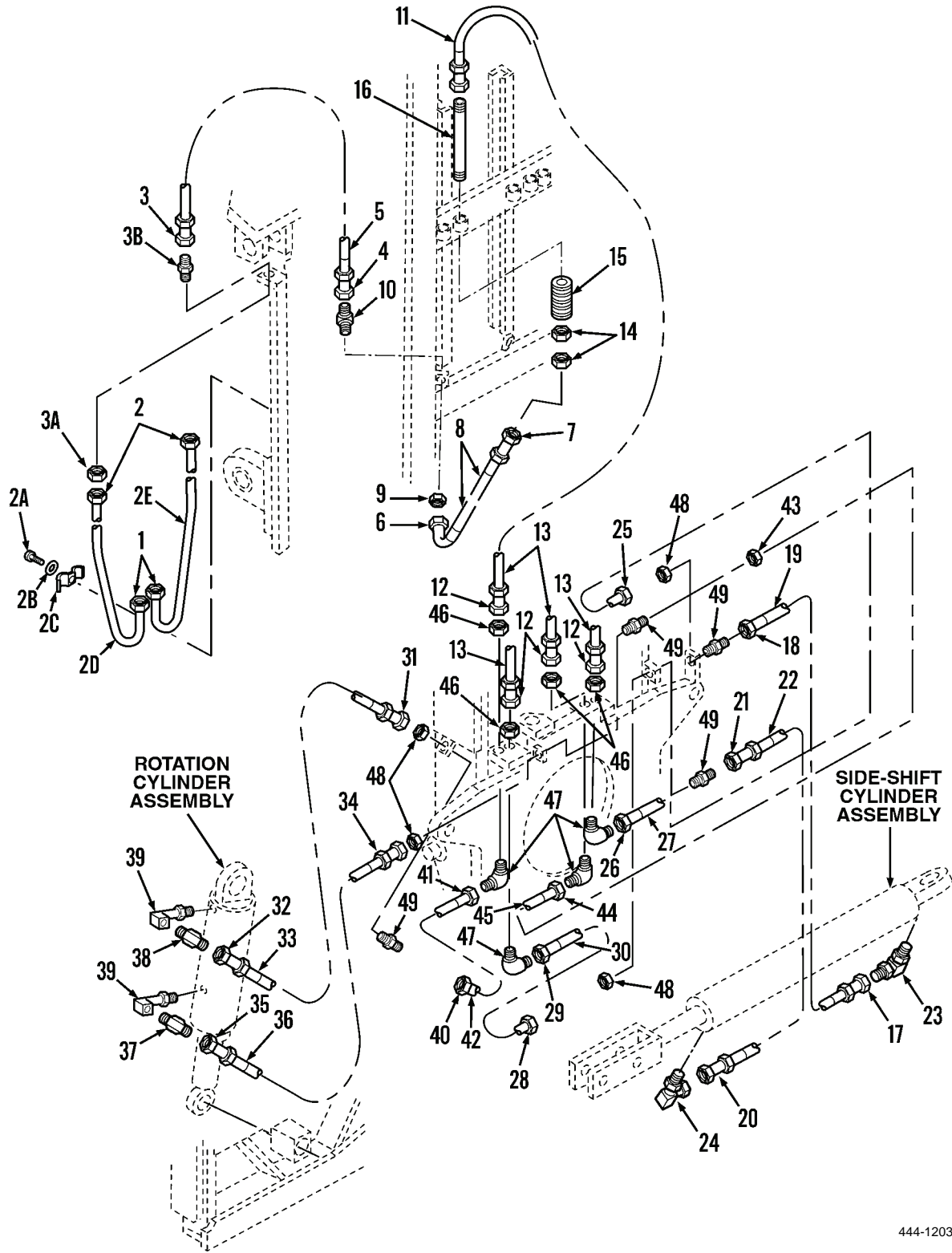

444-1203

Figure 7. Hydraulic Hoses, Lines, and Fittings.

END OF TASK  
END OF WORK PACKAGE



---

## ORGANIZATIONAL MAINTENANCE INSTRUCTIONS

### DRAINING AND FILLING HYDRAULIC RESERVOIR

#### Draining, Cleaning, Filling

---

#### INITIAL SETUP

**Maintenance Level**

Organizational

**Tools and Special Tools**

Tool kit, general mechanic's (Item 15, WP 0309)  
Shop equipment, common no. 1 (Item 2, WP 0309)  
Container, 18-gal. capacity

**Materials/Parts**

Cleaning compound, solvent (Item 10, WP 0310)  
Lubricating oil, OE/HDO-15/40 (Item 21, WP 0310)  
Rag, wiping (Item 26, WP 0310)  
Air breather  
Oil filter

**Materials/Parts - Continued**

O-ring (2)

**References**

LO 10-3930-638-12  
WP 0199  
WP 0200  
WP 0201

**Equipment Condition**

Vehicle parked on level surface  
Engine OFF  
Parking brake applied  
Right side panel removed (WP 0179)

---

**DRAINING**

1. Remove dipstick from top of hydraulic reservoir.
2. Position 18-gal. (68-L) container under magnetic drain plug (Figure 1, Item 1).
3. Remove magnetic drain plug (Figure 1, Item 1) and drain oil.
4. Clean magnetic drain plug (Figure 1, Item 1) and install.

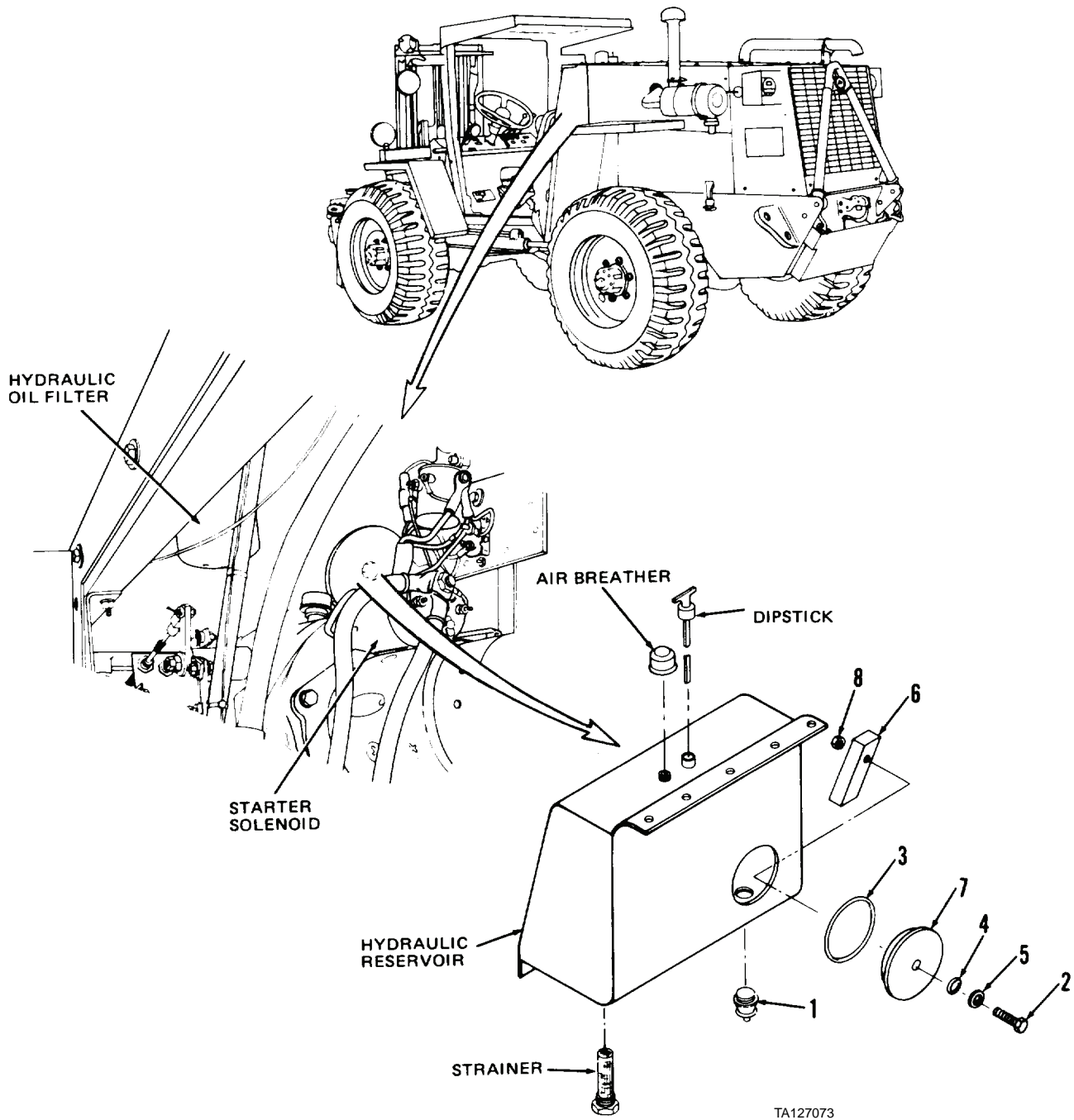

Figure 1. Draining, Cleaning, and Filling Hydraulic Reservoir.

**END OF TASK**

**CLEANING**

1. Loosen capscrew (Figure 1, Item 2) at rear of hydraulic reservoir, then remove cover (Figure 1, Item 7) and attached parts as an assembly.
2. Remove and discard O-ring (Figure 1, Item 3).

**WARNING**

Solvent cleaning compound MIL-PRF-680 Type III is an environmentally compliant and low toxic material. However, it may be irritating to the eyes and skin. Use protective gloves and goggles. Use in well-ventilated areas. Keep away from open flames and other sources of ignition. Failure to do so may result in injury or death to personnel.

3. Use clean rag moistened with solvent cleaning compound to clean interior of hydraulic reservoir interior. Wipe dry with clean rag.
4. Remove capscrew (Figure 1, Item 2), O-ring (Figure 1, Item 4), washer (Figure 1, Item 5), and nut (Figure 1, Item 8). Discard O-ring.
5. Remove hold-down bar (Figure 1, Item 6) and clean using clean rag moistened with solvent cleaning compound.
6. Use clean rag moistened with solvent cleaning compound to clean cover (Figure 1, Item 7).
7. Position hold-down bar (Figure 1, Item 6) on cover (Figure 1, Item 7).
8. Position washer (Figure 1, Item 5) and new O-ring (Figure 1, Item 4) on capscrew (Figure 1, Item 2).
9. Install capscrew (Figure 1, Item 2) loosely in cover (Figure 1, Item 7) and hold-down bar (Figure 1, Item 6).
10. Install nut (Figure 1, Item 8) on capscrew (Figure 1, Item 2).
11. Position new O-ring (Figure 1, Item 3) on cover (Figure 1, Item 7).
12. Install cover (Figure 1, Item 7) on hydraulic reservoir.
13. Tighten capscrew (Figure 1, Item 2) to draw cover tight.
14. Replace oil filter (WP 0199).
15. Clean strainer (WP 0200).
16. Replace air breather (WP 0201).

**END OF TASK****FILLING**

1. Fill hydraulic reservoir with oil to between FULL and ADD marks on dipstick. Refer to LO 10-3930-638-12.
2. Install dipstick on top of hydraulic reservoir.

**END OF TASK****END OF WORK PACKAGE**





---

# ORGANIZATIONAL MAINTENANCE INSTRUCTIONS

## HYDRAULIC OIL FILTER AND FILTER HEAD REPLACEMENT

### Removal, Cleaning, Inspection, Installation

---

#### INITIAL SETUP

**Maintenance Level**

Organizational

**Tools and Special Tools**

Tool kit, general mechanic's (Item 15, WP 0309)

Shop equipment, common no. 1 (Item 2, WP 0309)

**Materials/Parts**

Cleaning compound, solvent (Item 10, WP 0310)

Lubricating oil, OE/HDO-15/40 (Item 21, WP 0310)

Rag, wiping (Item 26, WP 0310)

**Materials/Parts - Continued**

Oil filter

**References**

WP 0125

**Equipment Condition**

Vehicle parked on level surface

Engine OFF

Parking brake applied

Left side panel removed (WP 0179)

Hydraulic reservoir oil drained (WP 0198)

---

**REMOVAL**

1. Use clamp type filter wrench to remove hydraulic oil filter (Figure 1, Item 1).

**WARNING**

Solvent cleaning compound MIL-PRF-680 Type III is an environmentally compliant and low toxic material. However, it may be irritating to the eyes and skin. Use protective gloves and goggles. Use in well-ventilated areas. Keep away from open flames and other sources of ignition. Failure to do so may result in injury or death to personnel.

2. Use clean rag moistened with solvent cleaning compound to clean filter head assembly (Figure 1, Item 5).

**NOTE**

Do not perform the following steps unless filter head assembly, bypass valve, or bypass spring has been damaged and replacement is necessary.

3. Disconnect tube fitting (Figure 1, Item 2) from fitting (Figure 1, Item 4).
4. Remove hydraulic filter restriction switch (Figure 1, Item 3) (WP 0125).
5. Remove fitting (Figure 1, Item 4) from filter head assembly (Figure 1, Item 5).
6. Remove bypass valve (Figure 1, Item 6) from filter head assembly (Figure 1, Item 5).
7. Remove fitting (Figure 1, Item 8) and bypass spring (Figure 1, Item 7) from filter head assembly (Figure 1, Item 5).

**END OF TASK****CLEANING****WARNING**

Solvent cleaning compound MIL-PRF-680 Type III is an environmentally compliant and low toxic material. However, it may be irritating to the eyes and skin. Use protective gloves and goggles. Use in well-ventilated areas. Keep away from open flames and other sources of ignition. Failure to do so may result in injury or death to personnel.

Use solvent cleaning compound to clean all parts.

**END OF TASK****INSPECTION**

1. Inspect fittings (Figure 1, Items 4 and 8). Replace if threads damaged.
2. Inspect filter head assembly (Figure 1, Item 5). Replace if cracked, distorted, or threads damaged.
3. Inspect bypass valve (Figure 1, Item 6). Replace if damaged.
4. Inspect bypass spring (Figure 1, Item 7). Replace if deformed, damaged, or permanently set.

## INSPECTION - CONTINUED

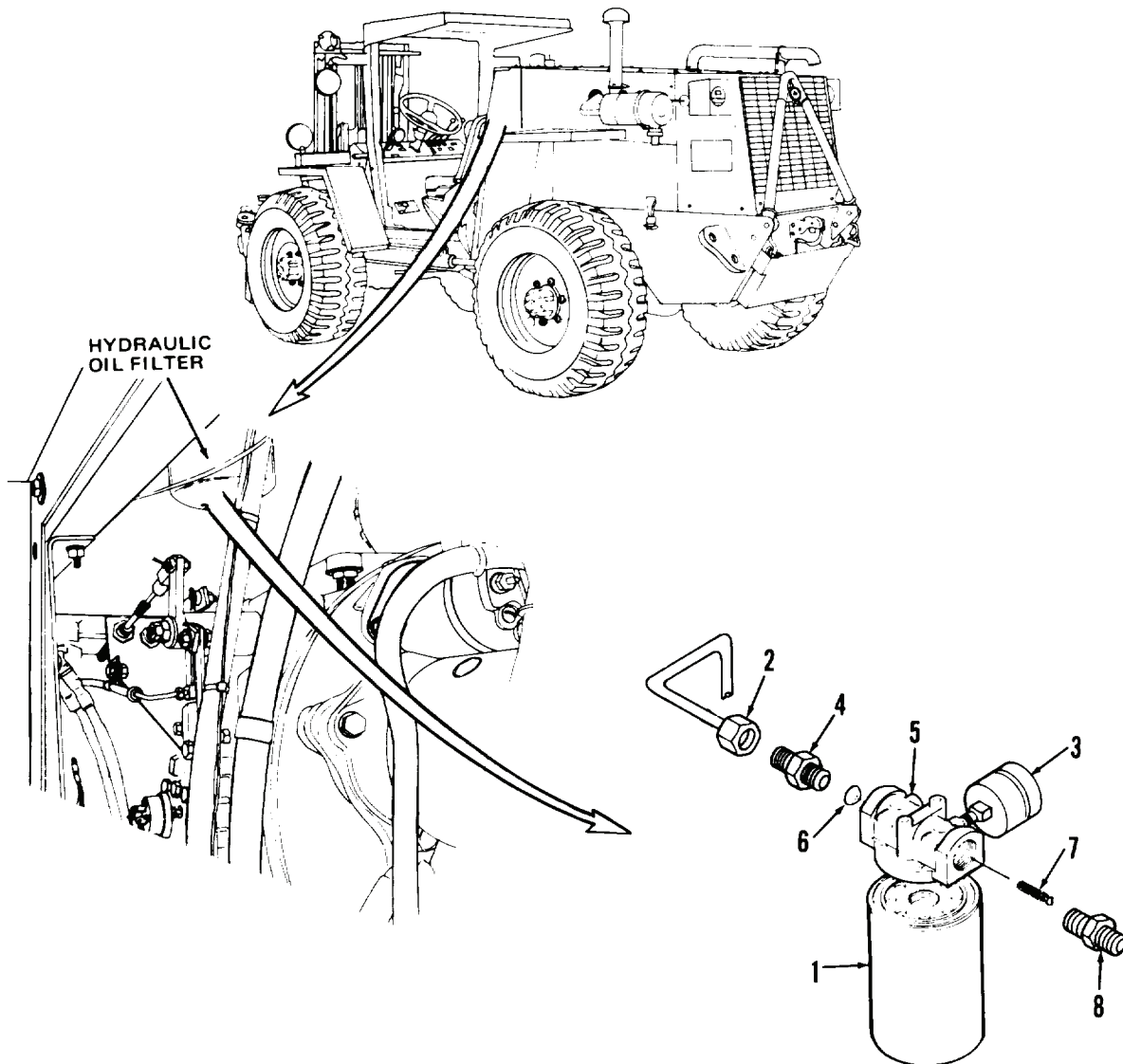

TA127074

Figure 1. Hydraulic Oil Filter and Filter Head.

## END OF TASK

## INSTALLATION

1. Install bypass spring (Figure 1, Item 7) and fitting (Figure 1, Item 8) in filter head assembly (Figure 1, Item 5).
2. Install bypass valve (Figure 1, Item 6) in filter head assembly (Figure 1, Item 5).
3. Install filter head assembly (Figure 1, Item 5) on fitting (Figure 1, Item 8).
4. Install fitting (Figure 1, Item 4) in filter head assembly (Figure 1, Item 5).
5. Install hydraulic filter restriction switch (Figure 1, Item 3) (WP 0125).
6. Connect tube fitting (Figure 1, Item 2) to fitting (Figure 1, Item 4) and tighten.
7. Install hydraulic oil filter (Figure 1, Item 1) until gasket contacts base. Then, tighten an additional one-half to three-quarters turn.

**INSTALLATION - CONTINUED**

8. Fill hydraulic reservoir with oil to between FULL and ADD marks on dipstick (WP 0198).
9. Start engine and operate at idle speed.
10. Check for oil leaks at oil filter; tighten if necessary.
11. Turn engine OFF.

**END OF TASK****END OF WORK PACKAGE**

---

## ORGANIZATIONAL MAINTENANCE INSTRUCTIONS

### HYDRAULIC OIL RESERVOIR STRAINER REPLACEMENT

#### Removal, Cleaning, Installation

---

#### INITIAL SETUP

**Maintenance Level**

Organizational

**Tools and Special Tools**

Tool kit, general mechanic's (Item 15, WP 0309)

Shop equipment, common no. 1 (Item 2, WP 0309)

**Materials/Parts**

Cap set, protective (Item 9, WP 0310)

Cleaning compound, solvent (Item 10, WP 0310)

**Materials/Parts - Continued**

Rag, wiping (Item 26, WP 0310)

**Equipment Condition**

Vehicle parked on level surface

Engine OFF

Parking brake applied

Left side panel removed (WP 0179)

Hydraulic reservoir oil drained (WP 0198)

Front cover panel removed (WP 0184)

---

**NOTE**

Cap all openings.

**REMOVAL**

1. Loosen hose clamp and disconnect hose from elbow (Figure 1).
2. Remove elbow from strainer.
3. Remove strainer from vehicle.

**END OF TASK****CLEANING****WARNING**

Solvent cleaning compound MIL-PRF-680 Type III is an environmentally compliant and low toxic material. However, it may be irritating to the eyes and skin. Use protective gloves and goggles. Use in well-ventilated areas. Keep away from open flames and other sources of ignition. Failure to do so may result in injury or death to personnel.

Clean strainer by immersing in solvent cleaning compound and dry using clean rag.

**END OF TASK****INSTALLATION**

1. Install strainer on vehicle (Figure 1).
2. Install elbow in strainer.
3. Connect hose to elbow.
4. Tighten hose clamp.
5. Fill hydraulic reservoir with oil to between FULL and ADD marks on dipstick (WP 0198).
6. Start engine and operate at idle speed while turning steering wheel to extreme right and left several times.
7. Increase engine speed and operate shift control lever to shift forks right and left several times.
8. Operate engine at idle speed and check for oil leaks at connections.
9. Turn engine OFF.
10. Check hydraulic reservoir oil level; fill as necessary (WP 0198).

## INSTALLATION - CONTINUED

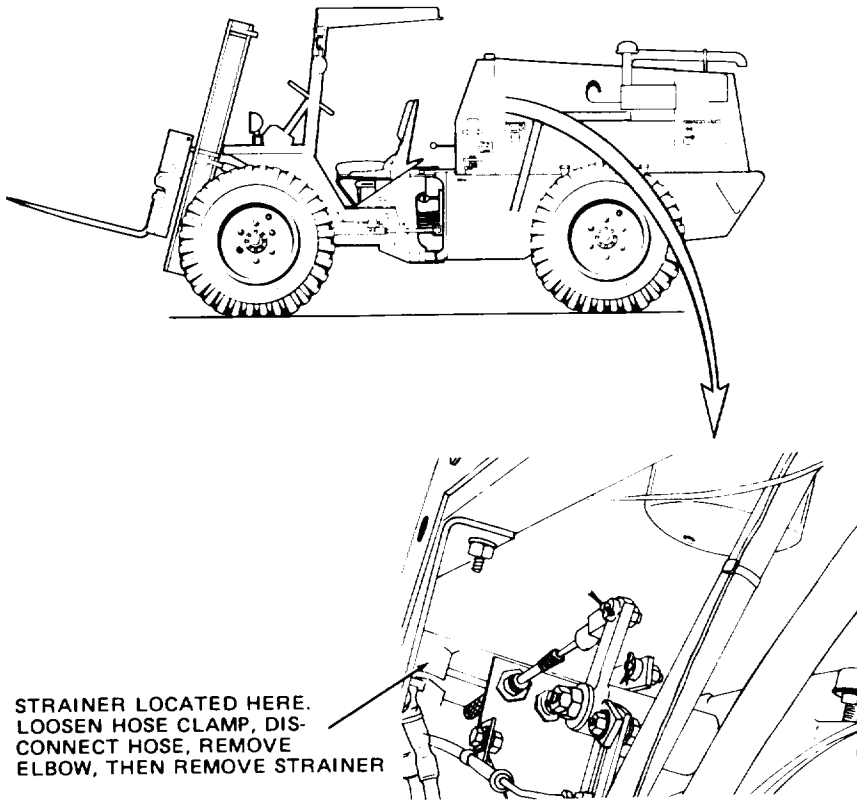

TA127075

Figure 1. Hydraulic Oil Reservoir Strainer.

END OF TASK

END OF WORK PACKAGE





---

## ORGANIZATIONAL MAINTENANCE INSTRUCTIONS

### HYDRAULIC OIL RESERVOIR AND AIR BREATHER REPLACEMENT

#### Removal, Cleaning, Inspection, Installation/Replacement

---

#### INITIAL SETUP

##### Maintenance Level

Organizational

##### Tools and Special Tools

Tool kit, general mechanic's (Item 15, WP 0309)  
Shop equipment, common no. 1 (Item 2, WP 0309)  
Chain hoist, 1/4-ton capacity  
Shop equipment, welding  
Steam cleaning equipment

##### Materials/Parts

Cleaning compound, solvent (Item 10, WP 0310)  
Rag, wiping (Item 26, WP 0310)  
Air breather

##### Materials/Parts - continued

Lockwasher (17)

##### Equipment Condition

Vehicle parked on level surface  
Engine OFF  
Parking brake applied  
Hydraulic reservoir oil drained and cover removed  
(WP 0198)  
Hydraulic oil filter removed (WP 0199)  
Hydraulic reservoir strainer removed (WP 0200)  
Dipstick removed (WP 0198)  
Front cover panel removed (WP 0184)  
Quick start kit removed (WP 0073, step 3)  
Air cleaner indicator removed (WP 0061, step 4)

---

**REMOVAL**

1. Turn air breather counter clockwise, remove, and discard (Figure 1).

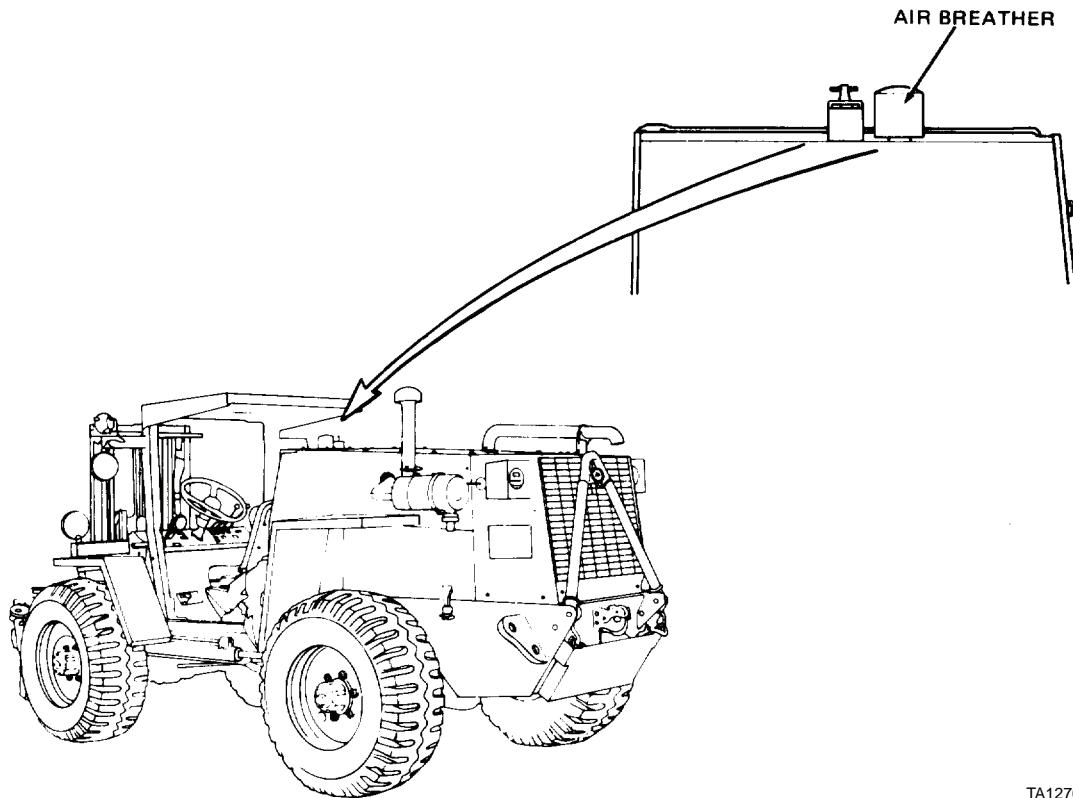

TA127076

**Figure 1. Air Breather.**

2. Remove five capscrews (Figure 2, Item 1), lockwashers (Figure 2, Item 2), and washers (Figure 2, Item 3) from top of hydraulic reservoir. Discard lockwashers.
3. Remove two capscrews (Figure 2, Item 4), lockwashers (Figure 2, Item 5), and washers (Figure 2, Item 6) from left side of hydraulic reservoir. Discard lockwashers.
4. Remove two capscrews (Figure 2, Item 7), lockwashers (Figure 2, Item 8), and washers (Figure 2, Item 9) from left side of hydraulic reservoir. Discard lockwashers.
5. Remove two capscrews (Figure 2, Item 10), lockwashers (Figure 2, Item 11), and washers (Figure 2, Item 12) from right side of hydraulic reservoir. Discard lockwashers.
6. Remove two capscrews (Figure 2, Item 13), lockwashers (Figure 2, Item 14), and washers (Figure 2, Item 15) from right side of hydraulic reservoir. Discard lockwashers.
7. Remove four capscrews (Figure 2, Item 16), nuts (Figure 2, Item 17), lockwashers (Figure 2, Item 18), and washers (Figure 2, Item 19) from bottom of hydraulic reservoir.
8. With lifting equipment, remove hydraulic reservoir (Figure 2, Item 20) from vehicle.

REMOVAL - CONTINUED

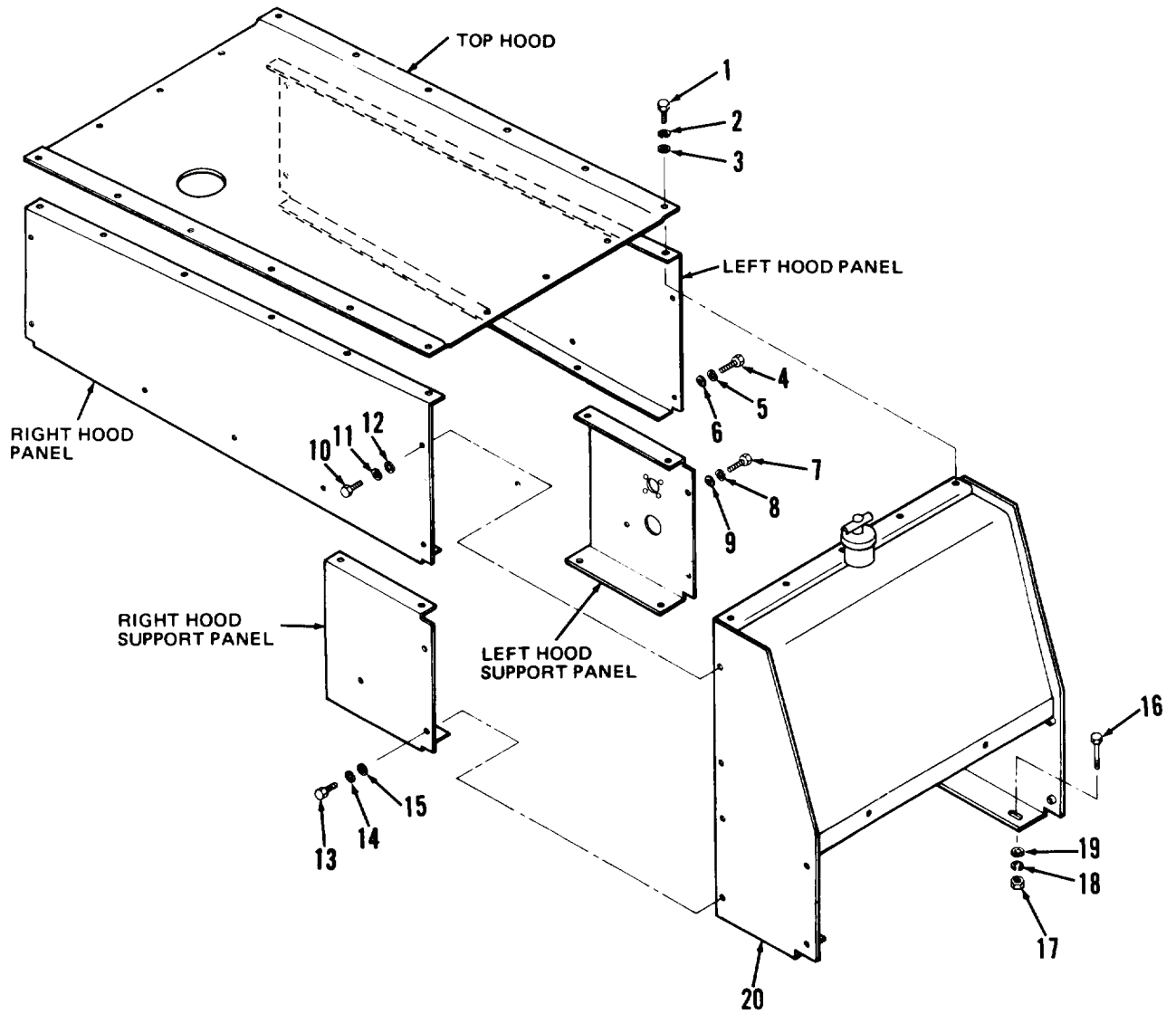

TA127077

Figure 2. Hydraulic Oil Reservoir.

END OF TASK

**CLEANING****WARNING**

Solvent cleaning compound MIL-PRF-680 Type III is an environmentally compliant and low toxic material. However, it may be irritating to the eyes and skin. Use protective gloves and goggles. Use in well-ventilated areas. Keep away from open flames and other sources of ignition. Failure to do so may result in injury or death to personnel.

1. Use solvent cleaning compound to clean exterior of hydraulic reservoir.
2. Use steam to clean interior of hydraulic reservoir.

**END OF TASK****INSPECTION**

1. Inspect hydraulic reservoir. Check for cracks, breaks, dents, and corrosion.
2. Hammer out dents in hydraulic reservoir.

**WARNING**

Hydraulic fluid is flammable. When welding hydraulic reservoir, partially fill it with water. Failure to do so may cause injury or death to personnel.

3. Weld cracks, breaks, leaks, or corrosion damage.

**END OF TASK****INSTALLATION/REPLACEMENT**

1. With lifting equipment, position hydraulic reservoir (Figure 3, Item 20) on rear chassis to remove chain hoist. Slide into position until mounting holes are aligned.
2. Install four capscrews (Figure 3, Item 16), new lockwashers (Figure 3, Item 18), washers (Figure 3, Item 19), and nuts (Figure 3, Item 17) on hydraulic reservoir (Figure 3, Item 20).
3. Install two washers (Figure 3, Item 15), new lockwashers (Figure 3, Item 14), and capscrews (Figure 3, Item 13) on right side of hydraulic reservoir (Figure 3, Item 20).
4. Install two washers (Figure 3, Item 12), new lockwashers (Figure 3, Item 11), and capscrews (Figure 3, Item 10) on right side of hydraulic reservoir (Figure 3, Item 20).
5. Install two washers (Figure 3, Item 9), new lockwashers (Figure 3, Item 8), and capscrews (Figure 3, Item 7) on left side of hydraulic reservoir (Figure 3, Item 20).
6. Install two washers (Figure 3, Item 6), new lockwashers (Figure 3, Item 5), and capscrews (Figure 3, Item 4) on left side of hydraulic reservoir (Figure 3, Item 20).
7. Install five washers (Figure 3, Item 3), new lockwashers (Figure 3, Item 2), and capscrews (Figure 3, Item 1) on top of hydraulic reservoir (Figure 3, Item 20).
8. Install new air breather and turn air breather clockwise.

INSTALLATION/REPLACEMENT - CONTINUED

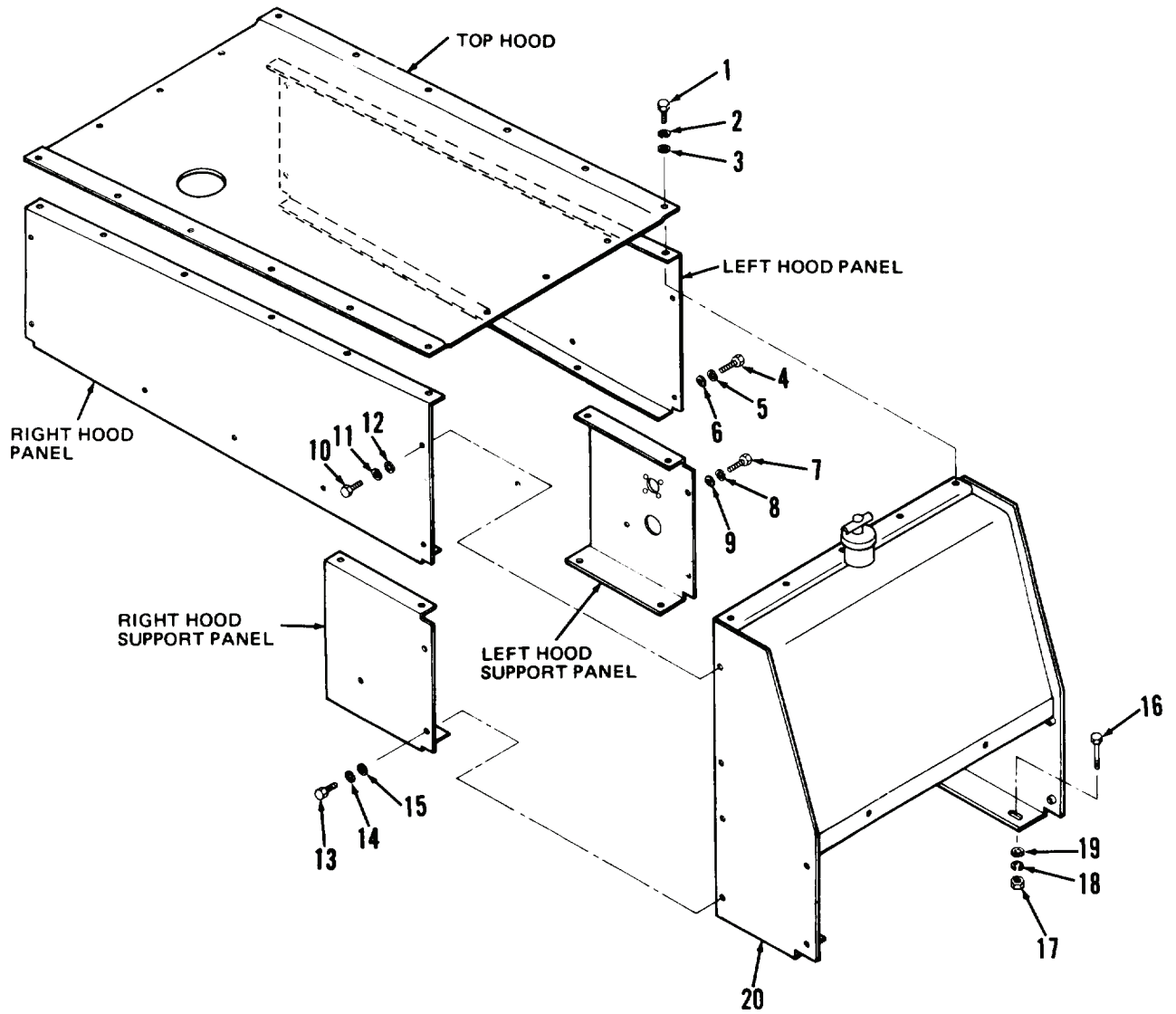

TA127077

Figure 3. Hydraulic Oil Reservoir.

END OF TASK

END OF WORK PACKAGE



# ORGANIZATIONAL MAINTENANCE INSTRUCTIONS

## GAGE BULB REPLACEMENT

### Removal, Installation

#### INITIAL SETUP

##### Maintenance Level

Organizational

##### Materials/Parts

Bulb

##### Equipment Condition

Ignition switch in OFF position and key removed

Noise baffle mat rod removed and mat pulled up and over instrument panel for access to bottom of instrument panel (WP 0187)

#### REMOVAL

1. Remove socket (Figure 1, Item 1) from gage (Figure 1, Item 3).
2. Remove and discard bulb (Figure 1, Item 2) from socket (Figure 1, Item 1).

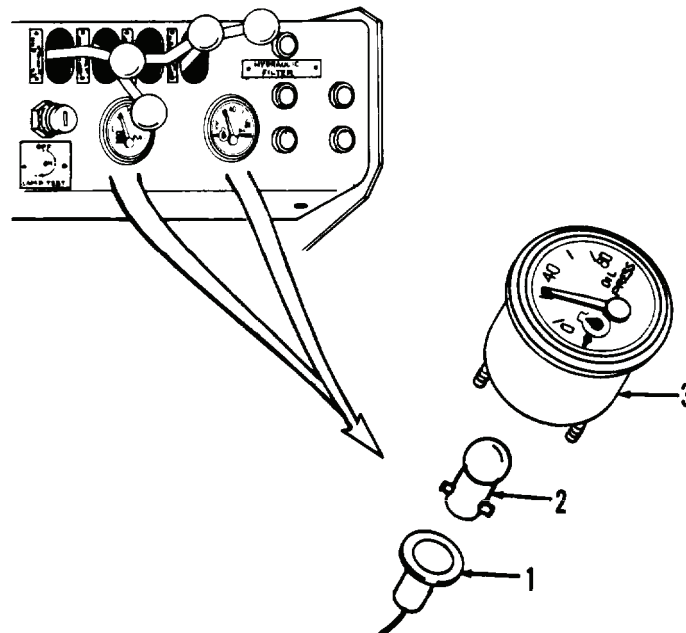

TA126892

Figure 1. Gage Bulb.

#### END OF TASK

#### INSTALLATION

1. Install new bulb (Figure 1, Item 2) on socket (Figure 1, Item 1). Push in until bulb snaps into position.
2. Install socket (Figure 1, Item 1) and new bulb (Figure 1, Item 2) in gage (Figure 1, Item 3).

#### END OF TASK

#### END OF WORK PACKAGE





---

# ORGANIZATIONAL MAINTENANCE INSTRUCTIONS

## GAGE REPLACEMENT

### Removal, Installation

---

#### INITIAL SETUP

##### Maintenance Level

Organizational

##### Tools and Special Tools

Shop equipment, common no. 1 (Item 2, WP 0309)

Tool kit, general mechanic's (Item 15, WP 0309)

##### Materials/Parts

Rag, wiping (Item 26, WP 0310)

Tag, marker (Item 33, WP 0310)

Lockwasher (2)

##### Equipment Condition

Ignition switch in OFF position and key removed

Gage socket and bulb removed (WP 0202)

---

**NOTE**

Tag all electrical leads before disconnecting.

**REMOVAL**

1. Remove two nuts (Figure 1, Item 2) and lockwashers (Figure 1, Item 3) from two mounting clamp screws (Figure 1, Item 4). Discard lockwashers.
2. Disconnect three wire leads (Figure 1, Item 1) from two mounting clamp screws (Figure 1, Item 4).
3. Remove mounting clamp (Figure 1, Item 5) from mounting clamp screws (Figure 1, Item 4) and gage (Figure 1, Item 6).
4. Remove gage (Figure 1, Item 6) from instrument panel.

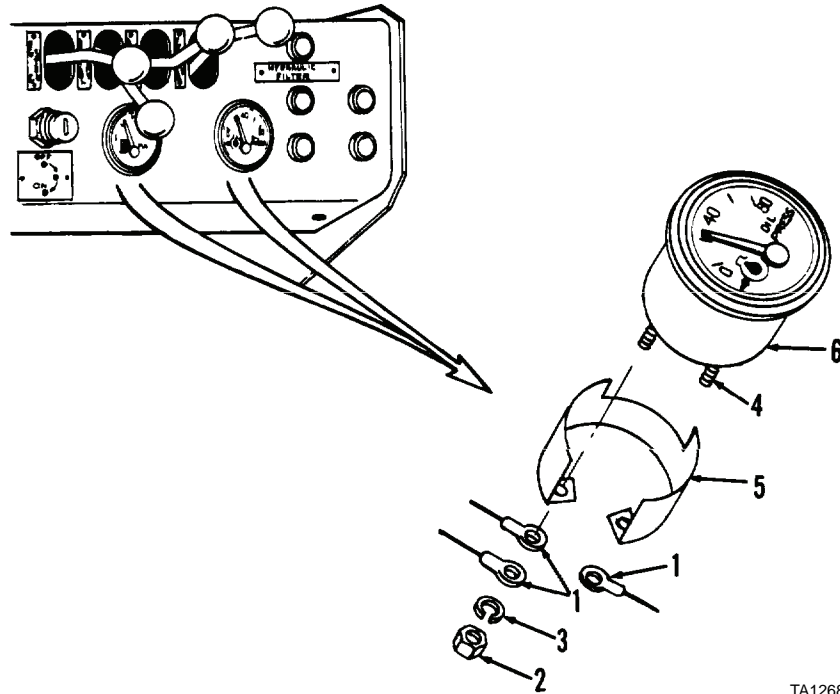

TA126893

**Figure 1. Gage.**

**END OF TASK****INSTALLATION**

1. Position gage (Figure 1, Item 6) on instrument panel.
2. Position mounting clamp (Figure 1, Item 5) on two mounting clamp screws (Figure 1, Item 4) and tighten mounting clamp screws evenly.
3. Connect three wire leads (Figure 1, Item 1) to two mounting clamp screws (Figure 1, Item 4).
4. Install two new lockwashers (Figure 1, Item 3) and nuts (Figure 1, Item 2) on two mounting clamp screws (Figure 1, Item 4).
5. Install gage socket and bulb (WP 0202).

**END OF TASK****END OF WORK PACKAGE**

**CHAPTER 5**  
**DIRECT SUPPORT MAINTENANCE INSTRUCTIONS**



---

## DIRECT SUPPORT MAINTENANCE INSTRUCTIONS

### LOCATING TOP DEAD CENTER (MODEL 207)

#### Locating Top Dead Center (TDC)

---

#### INITIAL SETUP

**Maintenance Level**

Direct Support

**Tools and Special Tools**

Tool kit, general mechanic's (Item 15, WP 0309)

**Materials/Parts**

Rag, wiping (Item 26, WP 0310)

**References**

WP 0206

**Equipment Condition**

Vehicle parked on level surface

Engine OFF

Parking brake applied

Left side panel removed (WP 0179)

Flywheel housing timing hole cover opened (WP 0220)

Rocker arm cover removed (WP 0222)

---

### LOCATING TOP DEAD CENTER (TDC)

1. At left side of engine compartment, rotate engine flywheel clockwise with blade of screwdriver engaging teeth of ring gear (Figure 1).
2. Rotate engine flywheel until pointer in timing hole is in line with TDC mark on flywheel.

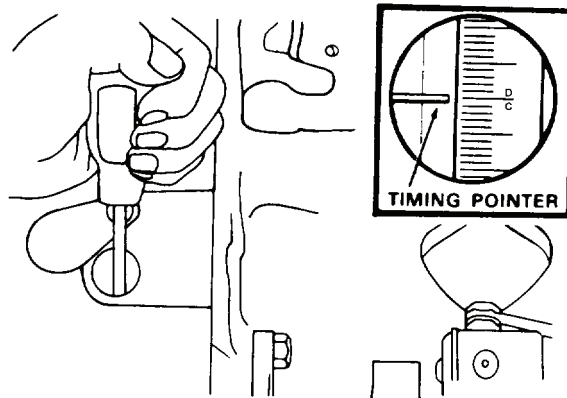

TA127227

**Figure 1. Locating Top Dead Center.**

3. Check push rods of No.1 cylinder for looseness. If push rods are loose, engine is at TDC. If push rods are still tight, rotate engine one additional revolution. Again, ensure push rods are loose. If loose, engine is at TDC.

### NOTE

Perform the following steps ONLY if accuracy of flywheel timing pointer is in doubt.

4. Rotate engine flywheel clockwise by engaging flywheel ring gear teeth with blade of screwdriver (Figure 2). Rotate engine until pointer in timing hole is in line with 10° before top dead center (BTDC) mark on flywheel.

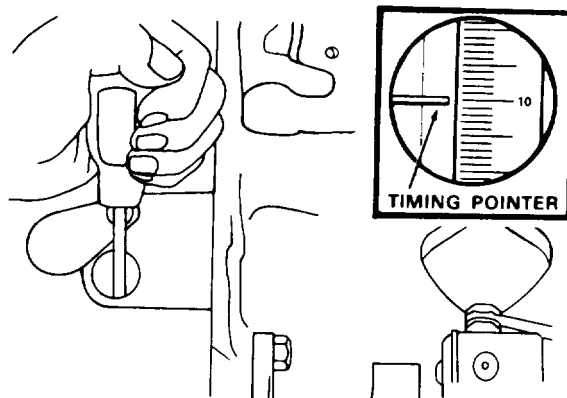

TA127059

**Figure 2. 10° Before Top Dead Center.**

**LOCATING TOP DEAD CENTER (TDC) - CONTINUED**

5. Use wrench to rotate rocker arm adjusting screw for No. 1 cylinder intake valve counterclockwise to loosen push rod (Figure 3).

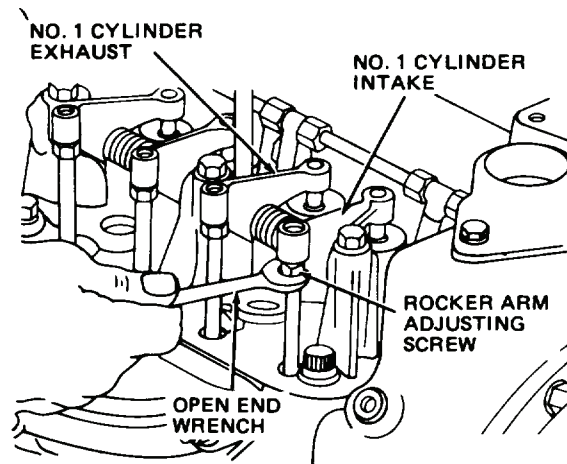

TA127080

**Figure 3. Rocker Arm Adjusting Screw.**

6. While pushing rocker arm downward against pressure of valve spring, remove push rod from engine.
7. Compress valve spring using screwdriver (Figure 4), remove two valve keepers of No. 1 cylinder intake valve, and slowly release screwdriver.

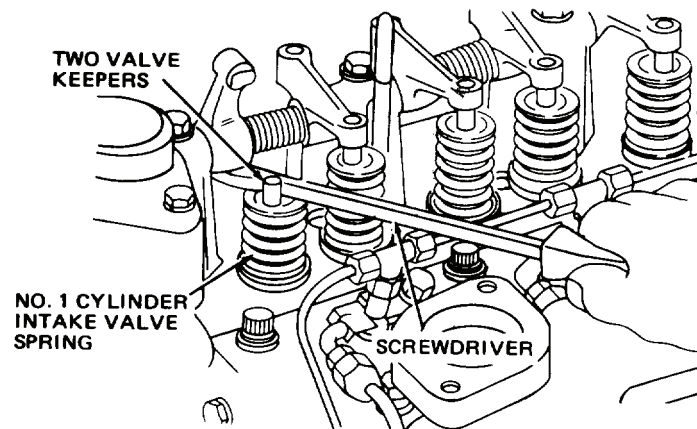

TA127081

**Figure 4. Two Valve Keepers.**

**LOCATING TOP DEAD CENTER (TDC) - CONTINUED**

8. Remove valve spring and seat from No. 1 cylinder intake valve (Figure 5).

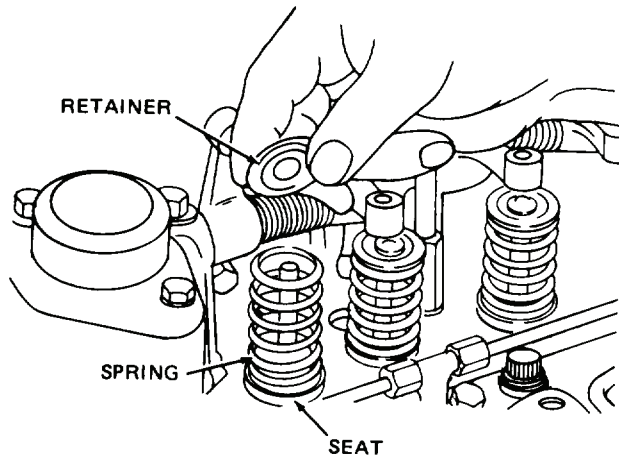

TA127082

**Figure 5. Valve Spring and Seat.****NOTE**

Do not remove seal from valve stem. If seal is removed, valve may fall through valve guide if piston is moved too far, requiring removal of cylinder head.

9. With valve resting on top of No. 1 piston, position dial indicator on end of valve stem (Figure 6).

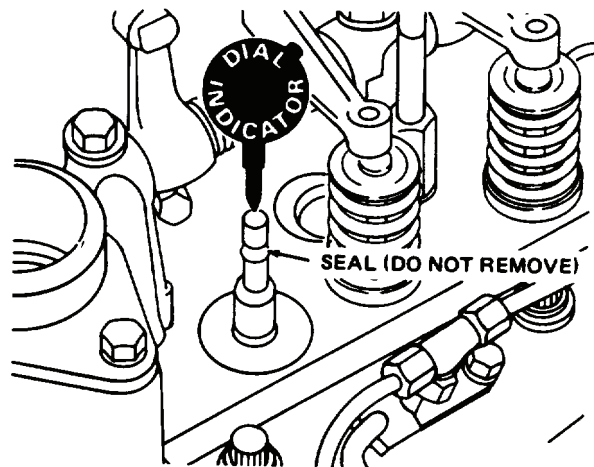

TA127083

**Figure 6. Dial Indicator.**



**LOCATING TOP DEAD CENTER (TDC) - CONTINUED**

10. Zero dial indicator.
11. Rotate engine flywheel clockwise until dial indicator pointer stops moving, then reset dial indicator to read zero.
12. Continue rotating engine flywheel clockwise until dial indicator reads 0.010 in. (0.25 mm). Scribe a mark on flywheel in line with timing pointer (Figure 7).

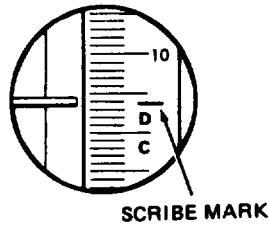

TA127084

**Figure 7. Scribe Mark on Flywheel.**

13. Rotate engine flywheel counterclockwise past dial indicator zero, until dial indicator reads 0.010 in. (0.25 mm). Scribe another mark on flywheel in line with timing pointer (Figure 8). Half the distance between these two scribe marks is TDC for No. 1 cylinder.

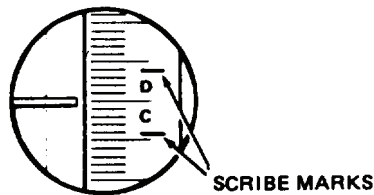

TA127085

**Figure 8. Two Scribe Marks on Flywheel.**

14. Remove seal from valve stem.

**NOTE**

Position spring with closed damping coil end against top of cylinder head as shown (Figure 9).

15. Install seat, valve spring, and retainer.

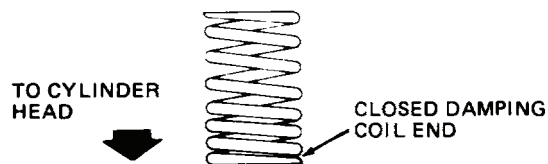

TA127086

**Figure 9. Valve Spring.**

**LOCATING TOP DEAD CENTER (TDC) - CONTINUED**

16. Install two valve keepers and new seal.
17. Compress valve spring using screwdriver (Figure 10).
18. Install new seal in lower groove of valve stem.
19. Install two keepers in upper groove of valve stem, and slowly release screwdriver. Gently tap end of valve stem to seat keepers.

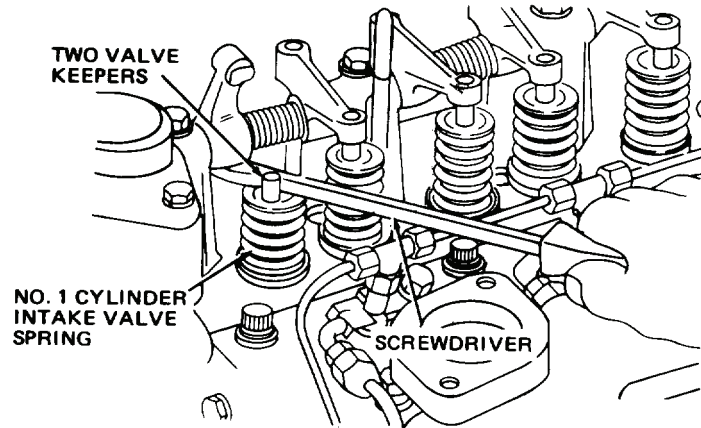

TA127081

**Figure 10. Two Valve Keepers.**

20. Push rocker arm down against valve spring.
21. Lower push rod into bore in cylinder head and position push rod beneath rocker arm adjusting screw. Release rocker arm.
22. Adjust tappet clearance of No. 1 cylinder intake valve (WP 0206).

**END OF TASK****END OF WORK PACKAGE**

---

## DIRECT SUPPORT MAINTENANCE INSTRUCTIONS

### LOCATING TOP DEAD CENTER (MODEL 4-390)

#### Locating Top Dead Center (TDC)

---

#### INITIAL SETUP

**Maintenance Level**

Direct Support

**Tools and Special Tools**

Tool kit, general mechanic's (Item 15, WP 0309)  
Shop equipment, common no. 1 (Item 2, WP 0309)  
Adapter, torque wrench (NSN 5120-00-018-1523,  
P/N CAS 1066A)  
Engine turnover tool (P/N CAS-1690)

**Materials/Parts**

Rag, wiping (Item 26, WP 0310)

**Equipment Condition**

Vehicle parked on level surface  
Engine OFF  
Parking brake applied  
Right side panel removed (WP 0179)

---

#### LOCATING TOP DEAD CENTER (TDC)

1. At right side of vehicle at engine flywheel housing, remove cover from access opening.
2. Insert engine turnover tool into access opening (Figure 1).

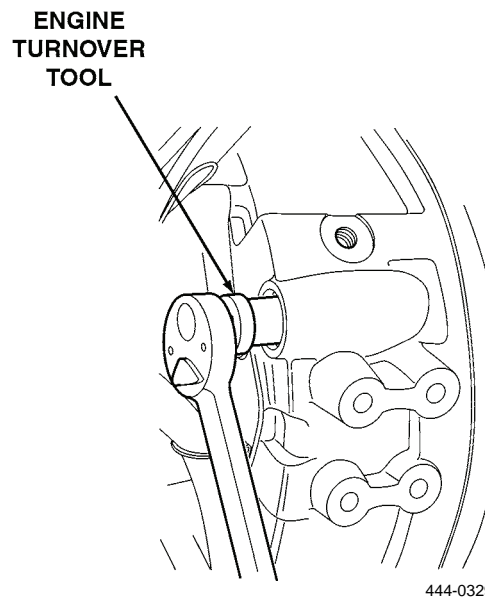
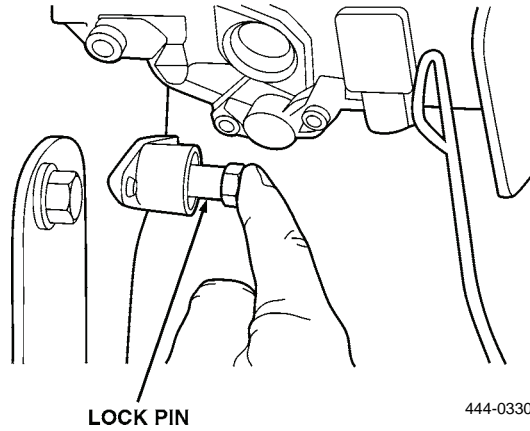

Figure 1. Engine Turnover Tool.

**LOCATING TOP DEAD CENTER - CONTINUED**

3. At right rear of engine compartment, press lock pin of engine while rotating engine with engine turnover tool (Figure 2).
4. When lock pin engages, engine is at top dead center (TDC).



**Figure 2. Lock Pin.**

**END OF TASK**

**END OF WORK PACKAGE**

## DIRECT SUPPORT MAINTENANCE INSTRUCTIONS

### VALVE TAPPET CLEARANCE ADJUSTMENT (MODEL 207)

Tappet Adjustment - Cold Setting, Tappet Adjustment - Hot Setting

#### INITIAL SETUP

##### Maintenance Level

Direct Support

##### Tools and Special Tools

Tool kit, general mechanic's (Item 15, WP 0309)  
Extension wrench (P/N M20419)

##### Materials/Parts

Lubricating oil, OE/HDO-15/40 (Item 21, WP 0310)  
Rag, wiping (Item 26, WP 0310)  
Rocker arm cover gasket

##### References

WP 0224

##### Equipment Condition

Vehicle parked on level surface  
Engine OFF  
Parking brake applied  
Left side panel removed (WP 0179)  
Top hood removed (WP 0180)  
Engine positioned at TDC for No. 1 cylinder (WP 0204)  
Rocker arm cover removed (WP 0222)

#### TAPPET ADJUSTMENT - COLD SETTING

#### NOTE

The cold setting valve tappet clearance must be adjusted whenever rocker arms or push rods have been removed. Do not attempt to start engine until cold setting tappet clearance adjustment has been performed.

1. At No.1 cylinder intake valve, loosen adjusting screw until a 0.012 in. (0.30 mm) feeler gage can be placed between rocker arm and valve stem (Figure 1), then turn adjusting screw clockwise until rocker arm-to-valve stem clearance is 0.012 in. (0.30 mm).

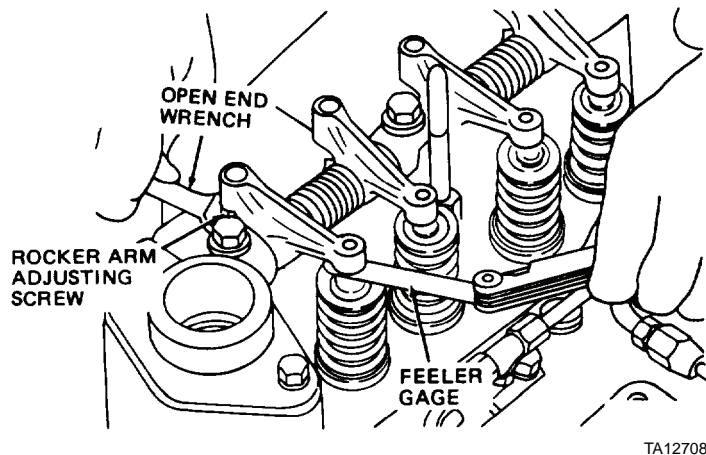
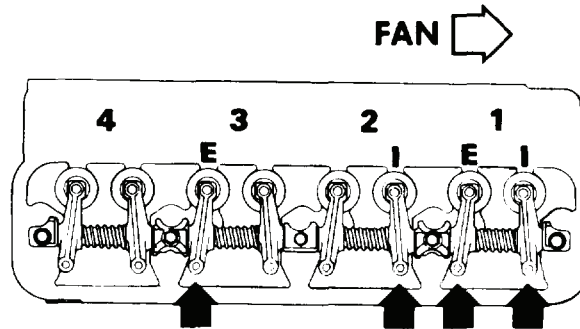

Figure 1. Valve Tappet Adjustment.

**TAPPET ADJUSTMENT - COLD SETTING - CONTINUED**

- Repeat step 1 to adjust intake and exhaust valves shown by arrows (Figure 2).

TAPPET CLEARANCE – INTAKE VALVES 0.012 INCH  
EXHAUST VALVES 0.014 INCH



TA127088

**Figure 2. Adjusting Four Intake and Exhaust Valves.**

- Rotate engine flywheel one complete revolution clockwise until pointer in timing hole is in line with TDC mark on flywheel (TDC position for No. 4 cylinder).
- Repeat step 1 to adjust intake and exhaust valves shown by arrows (Figure 3).

TAPPET CLEARANCE – INTAKE VALVES 0.012 INCH  
EXHAUST VALVES 0.014 INCH

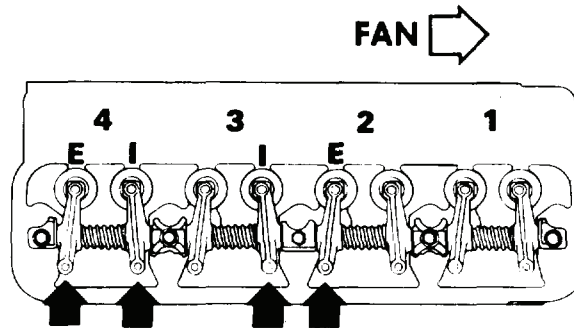

NO. 4 TDC COMPRESSION STROKE

TA127089

**Figure 3. Adjusting Remaining Four Intake and Exhaust Valves.**

- Lubricate valve stems by squirting oil through valve springs to lubricate stems before starting engine.
- Start engine and check oil pressure gage for normal indication. Visually check rocker arms to ensure they are receiving oil. Stop engine.
- Proceed to *Tappet Adjustment - Hot Setting* in this work package.

**END OF TASK**

**TAPPET ADJUSTMENT - HOT SETTING**

1. Install rocker arm cover (WP 0222).
2. Start engine and operate (under load if possible) approximately 1 hour. Stop engine.
3. Remove rocker arm cover (WP 0222).

**NOTE**

- Engine must be at normal operating temperature for each of the following steps. If necessary, restart and run engine to maintain normal operating temperature.
  - Performing step 4 will retorque cylinder head nuts and bolts.
  - Use extension wrench to torque nuts in positions 4 and 5.
4. Loosen bolt shown in position 1 approximately 1/4 turn, then tighten to 110 to 115 lb-ft (149 to 156 Nm). Using same procedure, retorque each cylinder head nut and bolt in sequence shown (Figure 4).

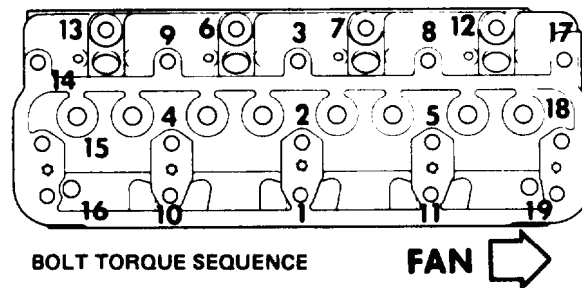

TA127090

**Figure 4. Bolt Tightening Sequence.**

5. Retorque rocker arm bracket bolts (WP 0224).
6. With engine at operating temperature, repeat step 4.
7. Install rocker arm cover (WP 0222).

**END OF TASK****END OF WORK PACKAGE**





# DIRECT SUPPORT MAINTENANCE INSTRUCTIONS

## VALVE TAPPET CLEARANCE ADJUSTMENT (MODEL 4-390)

### Adjustment

#### INITIAL SETUP

##### Maintenance Level

Direct Support

##### Tools and Special Tools

Tool kit, general mechanic's (Item 15, WP 0309)  
 Shop equipment, common no. 1 (Item 2, WP 0309)  
 Engine turnover tool (P/N CAS-1690)

##### Materials/Parts

Rag, wiping (Item 26, WP 0310)

##### Equipment Condition

Vehicle parked on level surface  
 Engine OFF  
 Parking brake applied  
 Right side panel removed (WP 0179)  
 Top hood removed (WP 0181)  
 Engine positioned at TDC (WP 0205)  
 Rocker arm cover removed (WP 0223)

#### ADJUSTMENT

#### NOTE

- The cold setting valve tappet clearance must be adjusted whenever arms or push rods have been removed. Do not attempt to start engine until cold setting tappet clearance adjustment has been performed.
  - Rocker arm adjusting screw for No. 1 cylinder intake valve is shown in Figure 1.
1. Adjust intake valve adjusting screws by loosening each adjusting screw until a 0.010 in. (0.25 mm) feeler gage can be placed between rocker arm and intake valve stem (Figure 1), then turn adjusting screw clockwise until rocker arm-to-intake valve stem clearance is 0.010 in. (0.25 mm).
  2. For each exhaust valve stem, clearance should be 0.020 in. (0.51 mm).

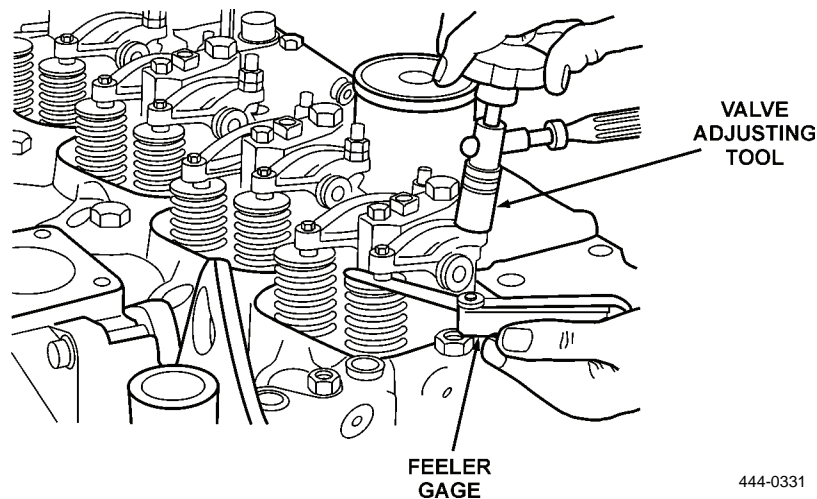

444-0331

**Figure 1. Valve Tappet Adjustment.**

**ADJUSTMENT - CONTINUED**

3. Insert engine turnover tool into opening in engine flywheel housing (Figure 2).
4. Move flywheel a small amount in each direction in order to free lock pin. Disengage lock pin (Figure 2).

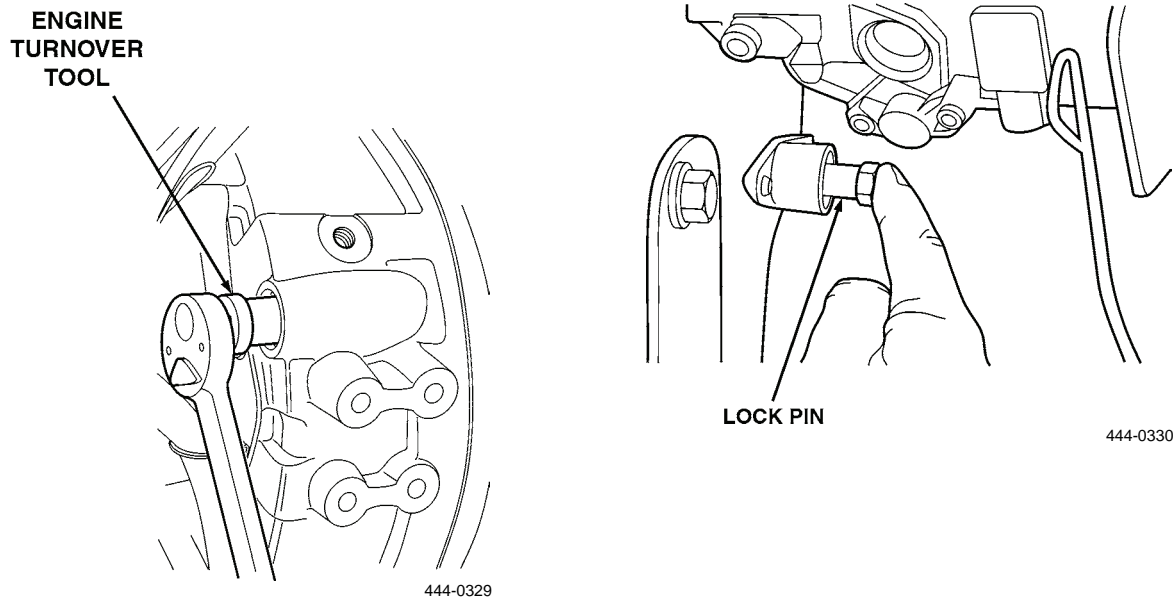

**Figure 2. Engine Turnover Tool and Lock Pin.**

5. Rotate flywheel one complete revolution.
6. Check and adjust valve clearances. Intake valve clearance should be 0.010 in. (0.25 mm) and exhaust valve clearance should be 0.020 in. (0.51 mm).

**END OF TASK**

**END OF WORK PACKAGE**

## DIRECT SUPPORT MAINTENANCE INSTRUCTIONS

### FUEL INJECTION PUMP ADJUSTMENTS (MODEL 207) Injection Pump - Timing Adjustment, Engine Idle Speed Adjustment, Engine No-Load Governed Speed Adjustment

#### INITIAL SETUP

##### Maintenance Level

Direct Support

##### Personnel Required

Two

##### Tools and Special Tools

Tool kit, general mechanic's (Item 15, WP 0309)

##### References

WP 0074

##### Materials/Parts

Rag, wiping (Item 26, WP 0310)

Timing window gasket

Wire seal (2)

##### Equipment Condition

Vehicle parked on level surface

Engine OFF

Parking brake applied

Left and right side panels removed (WP 0179)

Tachometer drive cover removed (WP 0217)

#### INJECTION PUMP - TIMING ADJUSTMENT

1. At left side of engine compartment, engage flywheel ring gear teeth with blade of screwdriver (Figure 1). Rotate engine counterclockwise until pointer in timing hole is past 8° BTDC mark on flywheel. Then, rotate engine clockwise until pointer is in line with 8° BTDC mark on flywheel.

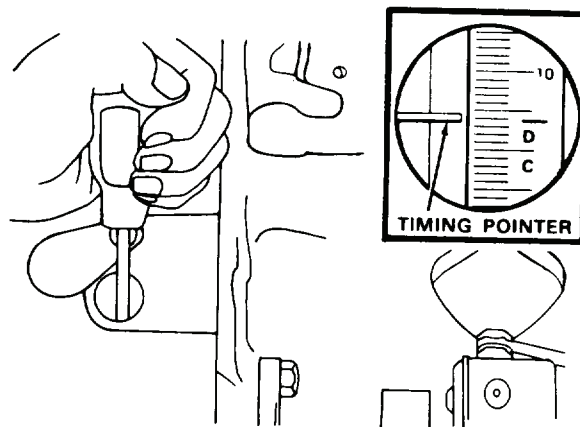

TA127079

Figure 1. Rotating Flywheel Toward 8° Before Top Dead Center.

**INJECTION PUMP - TIMING ADJUSTMENT - CONTINUED**

- At fuel injection pump, remove screws, cover, and gasket of timing window (Figure 2). Discard gasket.

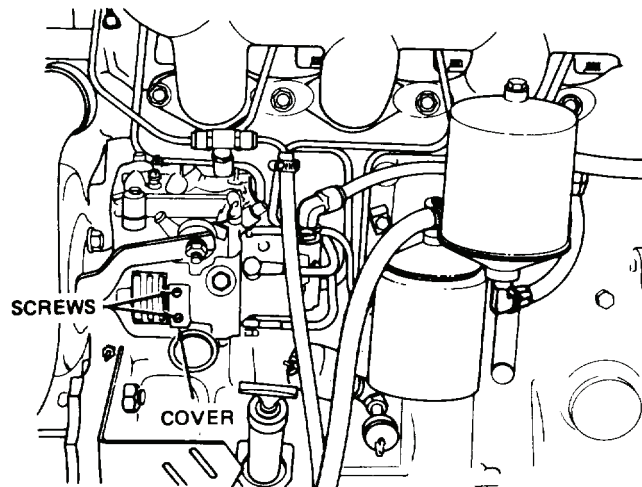

TA127091

**Figure 2. Timing Window Screws, Cover, and Gasket.****NOTE**

If both timing marks are not visible in step 3, rotate engine one complete revolution and repeat step 1.

- Observe alignment of timing marks. If timing marks are aligned as shown (Figure 3), proceed to step 8. If marks are not aligned, proceed to step 4.

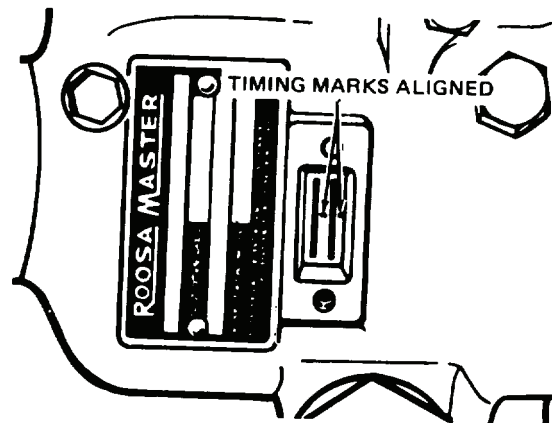

TA127092

**Figure 3. Timing Marks.**

**INJECTION PUMP - TIMING ADJUSTMENT - CONTINUED**

- Loosen three mounting nuts of fuel injection pump (Figure 4).

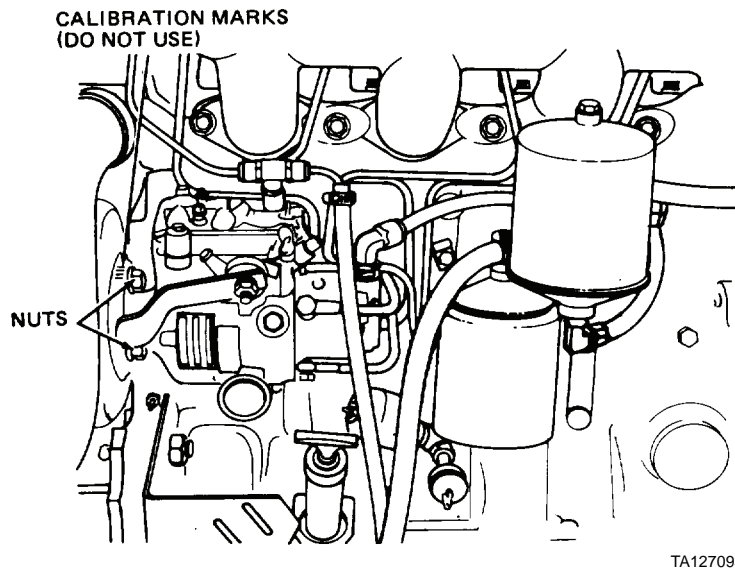

**Figure 4. Mounting Nuts of Fuel Injection Pump.**

**NOTE**

- Do not use calibration marks in step 5. Use marks in injection pump timing window only.
  - To advance timing, rotate top of pump away from engine. To retard timing, rotate top of pump toward engine.
- Rotate fuel injection pump until timing marks in timing window are in line.
  - Tighten three mounting nuts to 35 to 42 lb-ft (47 to 57 Nm).
  - Check injection pump timing again. Repeat steps 4 through 6 until timing marks are in line.
  - Install new gasket and cover on timing window with screws (Figure 2).

**END OF TASK**

## ENGINE IDLE SPEED ADJUSTMENT

1. Start engine and operate until normal operating temperature is reached.

### NOTE

Tachometer drive shaft operates at 1/2 engine speed. Double tachometer reading to obtain engine RPM.

2. With engine idling, press conical tip of tachometer against tachometer drive shaft on engine until tachometer hand stops moving, then note reading (Figure 5).

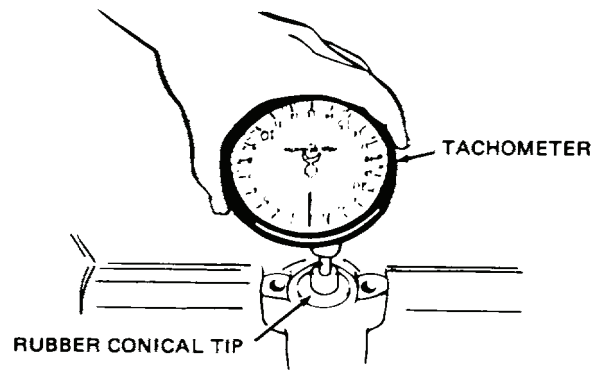

Figure 5. Tachometer.

3. Repeat step 2 to recheck idle speed. If engine idle speed is 825 to 850 RPM, proceed to *Engine No-Load Governed Speed Adjustment* in this work package. If idle speed is not correct, proceed to step 4.
4. With accelerator pedal at idle position, verify idle-speed screw is against injection pump boss (Figure 6). If screw is NOT against pump boss, adjust accelerator cable ball joint (WP 0074). If screw is against pump boss, proceed to step 5.

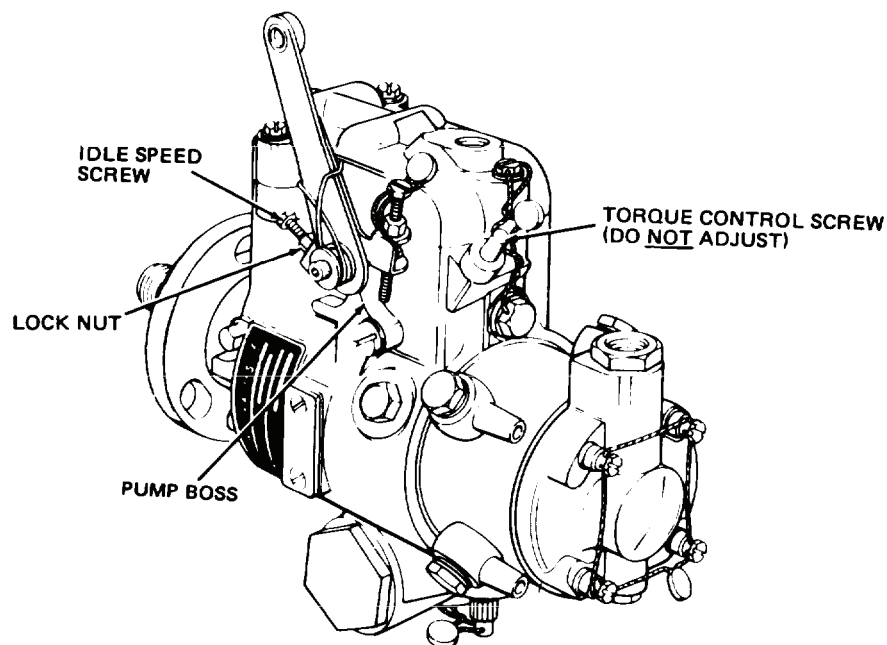

Figure 6. Injection Pump Idle Speed Screw.

**ENGINE IDLE SPEED ADJUSTMENT - CONTINUED**

- Cut and remove wire seal of idle-speed screw. Discard wire seal.

**NOTE**

Turn idle-speed screw out (counterclockwise) to decrease engine speed. Turn idle-speed screw in (clockwise) to increase engine idle-speed.

- Loosen locknut and adjust idle-speed screw 1/2 turn at a time and recheck engine idle speed. Repeat until engine idles at 825 to 850 RPM.
- While holding idle-speed screw, tighten locknut.
- Install new wire seal on idle-speed screw.

**END OF TASK****ENGINE NO-LOAD GOVERNED SPEED ADJUSTMENT**

- While an assistant fully depresses accelerator pedal, verify high-speed screw is against injection pump boss pedal (Figure 7). If screw is NOT against pump boss, adjust accelerator cable ball joint (WP 0074).

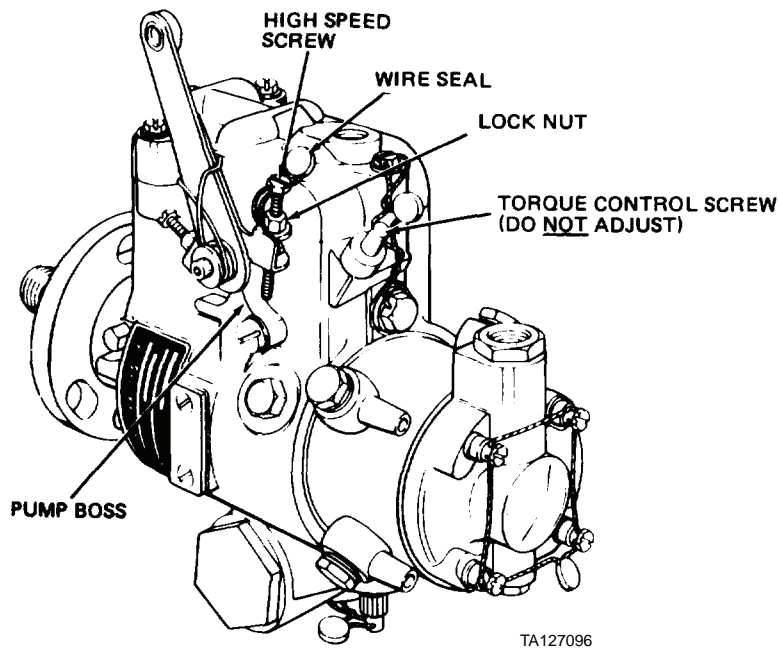

**Figure 7. Injection Pump High Speed Screw.**

- Start engine and operate until normal operating temperature is reached.

**ENGINE NO-LOAD GOVERNED SPEED ADJUSTMENT - CONTINUED****NOTE**

Tachometer drive shaft operates at 1/2 engine speed. Double tachometer reading to obtain engine RPM.

3. With accelerator pedal fully depressed, press conical tip of tachometer against tachometer drive shaft on engine until tachometer hand stops moving, then note reading (Figure 8).

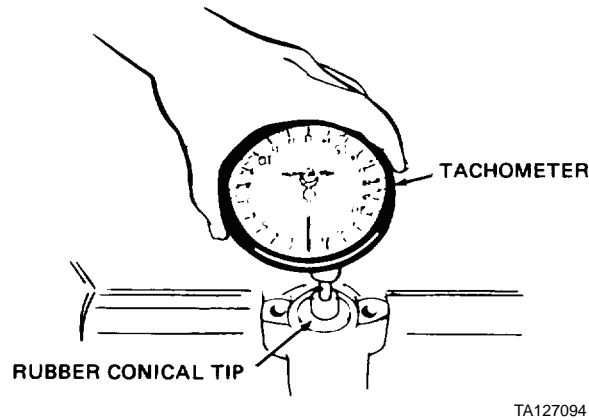

**Figure 8. Tachometer.**

4. Repeat step 3 to recheck no-load governed speed. If no-load governed speed is 2,230 to 2,270 RPM, proceed to step 9. If speed is NOT correct, proceed to step 5.
5. Cut and remove wire seal of high-speed screw. Discard wire seal.

**NOTE**

Turn high-speed screw out (counterclockwise) to increase engine speed. Turn high-speed screw in (clockwise) to decrease engine no-load governed speed.

6. Loosen locknut of high speed screw and adjust 1/2 turn at a time and recheck no-load governed speed. Repeat until engine no-load governed speed is 2,230 to 2,270 RPM.
7. While holding high-speed screw, tighten locknut.
8. Install new wire seal on high-speed screw.
9. Install tachometer drive cover (WP 0217).

**END OF TASK**

**END OF WORK PACKAGE**



---

## DIRECT SUPPORT MAINTENANCE INSTRUCTIONS

### ENGINE MOUNT REPLACEMENT (MODEL 207)

#### Removal, Cleaning, Inspection, Installation

---

#### INITIAL SETUP

**Maintenance Level**

Direct Support

**Tools and Special Tools**

Tool kit, general mechanic's (Item 15, WP 0309)

Shop equipment, common no. 1 (Item 2, WP 0309)

Hex nut, 5/8-1 UNC

Sleeve, 1-1/2 in. dia. x 1 in. long

Sling and hoist, 1-ton capacity

**Materials/Parts**

Cleaning compound, solvent (Item 10, WP 0310)

Detergent, liquid (Item 13, WP 0310)

**Materials/Parts - Continued**

Rag, wiping (Item 26, WP 0310)

Locknut

Rubber mount

**Personnel Required**

Two

**Equipment Condition**

Vehicle parked on level surface

Engine OFF

Parking brake applied

Radiator shroud (with radiator and oil cooler still attached) removed (WP 0082)

---

**REMOVAL**

1. At rear of engine compartment, remove locknut (Figure 1, Item 1) and washer (Figure 1, Item 2) from capscrew (Figure 1, Item 4). Discard locknut.

**WARNING**

Keep hands and body clear while engine is being raised. When engine mount bracket is clear of frame, support engine using blocks to prevent engine from falling while replacing engine mount. Failure to do so may result in injury or death to personnel due to engine falling.

2. Loosen two mounting bolts of transmission mounts before performing step 3.
3. Using sling and hoist, lift rear of engine. Lift until engine mount (Figure 1, Item 6) will clear frame and engine mount bracket.
4. Remove capscrew (Figure 1, Item 4), washer (Figure 1, Item 5), and washer (Figure 1, Item 3).
5. Remove engine mount (Figure 1, Item 6) from engine mount bracket. Discard engine mount.

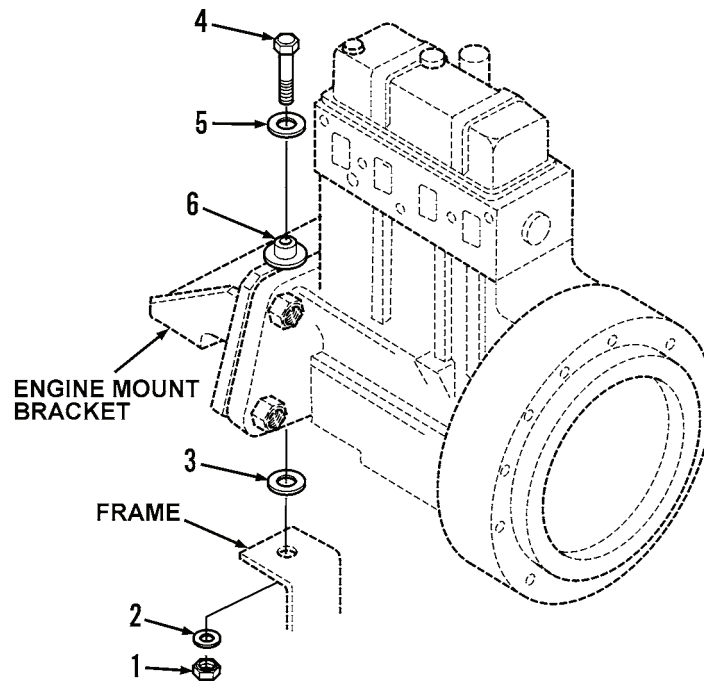

444-1223

**Figure 1. Engine Mount.****END OF TASK**

**CLEANING****WARNING**

- Solvent cleaning compound MIL-PRF-680 Type III is an environmentally compliant and low toxic material. However, it may be irritating to the eyes and skin. Use protective gloves and goggles. Use in well-ventilated areas. Keep away from open flames and other sources of ignition. Failure to do so may result in injury or death to personnel.
- Particles blown by compressed air are hazardous. DO NOT exceed 15 PSI (103 kPa) nozzle pressure when drying parts with compressed air. DO NOT direct compressed air against human skin. Make sure air stream is directed away from user and other personnel in the area. To prevent injury, user must wear protective goggles or face shield. Failure to follow this warning may result in injury to personnel.

Clean capscrew, washers, and engine mount bracket with solvent cleaning compound. Dry thoroughly with compressed air.

**END OF TASK****INSPECTION**

1. Inspect washers. Replace if worn.
2. Inspect capscrew. Replace if bent, stretched, or threads are damaged.

**END OF TASK**

**INSTALLATION**

1. Apply rubber lubricant or liquid soap to new engine mount (Figure 2, Item 6).

**CAUTION**

Do not attempt to install engine mount using hammer. Driving mount into engine mount bracket may damage rubber.

2. Using hardware shown in Figure 2, press new engine mount (Figure 2, Item 6) into engine mount bracket until it is seated against engine mount bracket. Remove hardware.
3. Position washer (Figure 2, Item 3) on frame of vehicle with holes aligned.

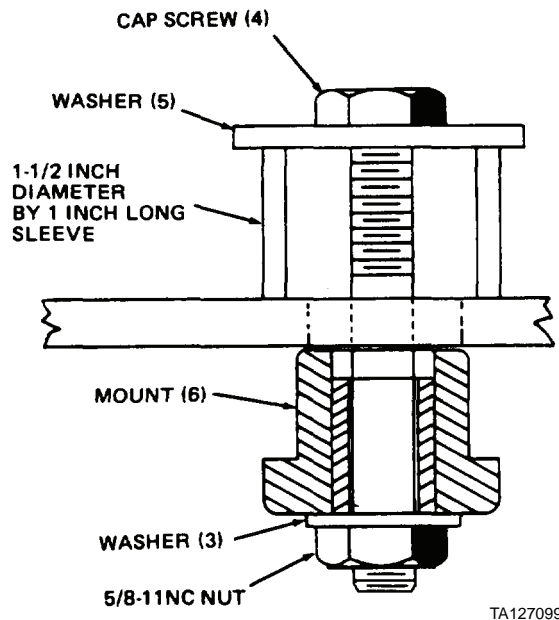

TA127099

**Figure 2. Detail of Engine Mount.**

## INSTALLATION - CONTINUED

**WARNING**

Keep hands and body clear while engine is being lowered. Failure to do so could cause injury or death to personnel due to engine falling.

4. Remove support blocks and lower engine using hoist. Ensure engine mount (Figure 3, Item 6), washer (Figure 3, Item 3), and frame holes are aligned.
5. Install washer (Figure 3, Item 5), capscrew (Figure 3, Item 4), washer (Figure 3, Item 2), and new locknut (Figure 3, Item 1). Tighten locknut.

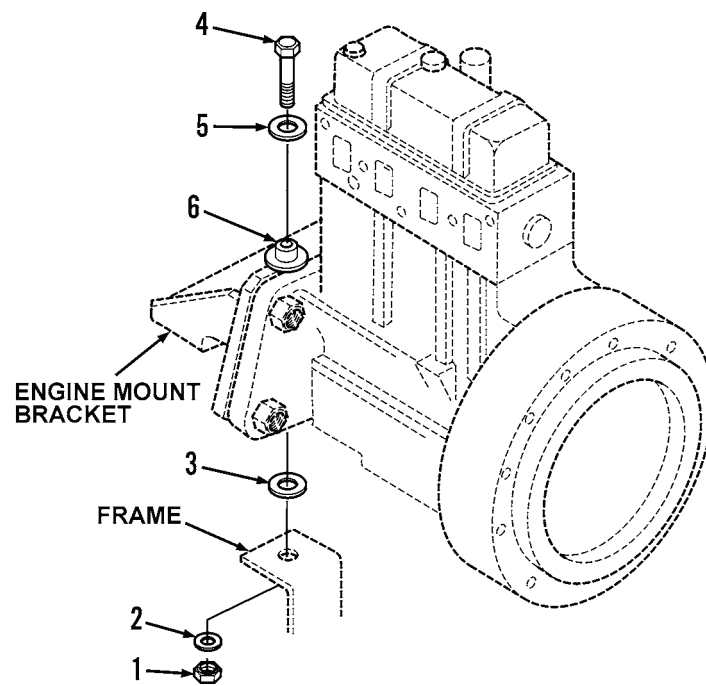

444-1223

**Figure 3. Engine Mount.**

6. Tighten two mounting bolts of transmission mounts.
7. Install radiator shroud (WP 0082).

**END OF TASK**

**END OF WORK PACKAGE**



---

## DIRECT SUPPORT MAINTENANCE INSTRUCTIONS

### ENGINE MOUNT REPLACEMENT (MODEL 4-390)

Removal, Cleaning, Inspection, Installation

---

#### INITIAL SETUP

**Maintenance Level**

Direct Support

**Tools and Special Tools**

Tool kit, general mechanic's (Item 15, WP 0309)

Sling and hoist, 1-ton capacity

**Materials/Parts**

Cleaning compound, solvent (Item 10, WP 0310)

Rag, wiping (Item 26, WP 0310)

Lockwasher (4)

**Personnel Required**

Two

**Equipment Condition**

Vehicle parked on level surface

Engine OFF

Parking brake applied

Left and right side panels removed (WP 0179)

Top hood removed (WP 0181)

---

**REMOVAL**

1. In engine compartment, attach lifting equipment to both engine lifting brackets (Figure 1, Item 1) and take up slack.
2. At rear of engine compartment, remove capscrew (Figure 1, Item 2), nut (Figure 1, Item 3), and three washers (Figure 1, Item 4).
3. Remove four capscrews (Figure 1, Item 6) and lockwashers (Figure 1, Item 7) to separate bracket (Figure 1, Item 8) from engine. Discard lockwashers.
4. Remove engine mount bracket (Figure 1, Item 8) from engine compartment.
5. Remove two isolators (Figure 1, Item 5) from engine mount bracket (Figure 1, Item 8).
6. Remove four capscrews (Figure 1, Item 9), washers (Figure 1, Item 10), nuts (Figure 1, Item 11), and plate (Figure 1, Item 12) from rear chassis.

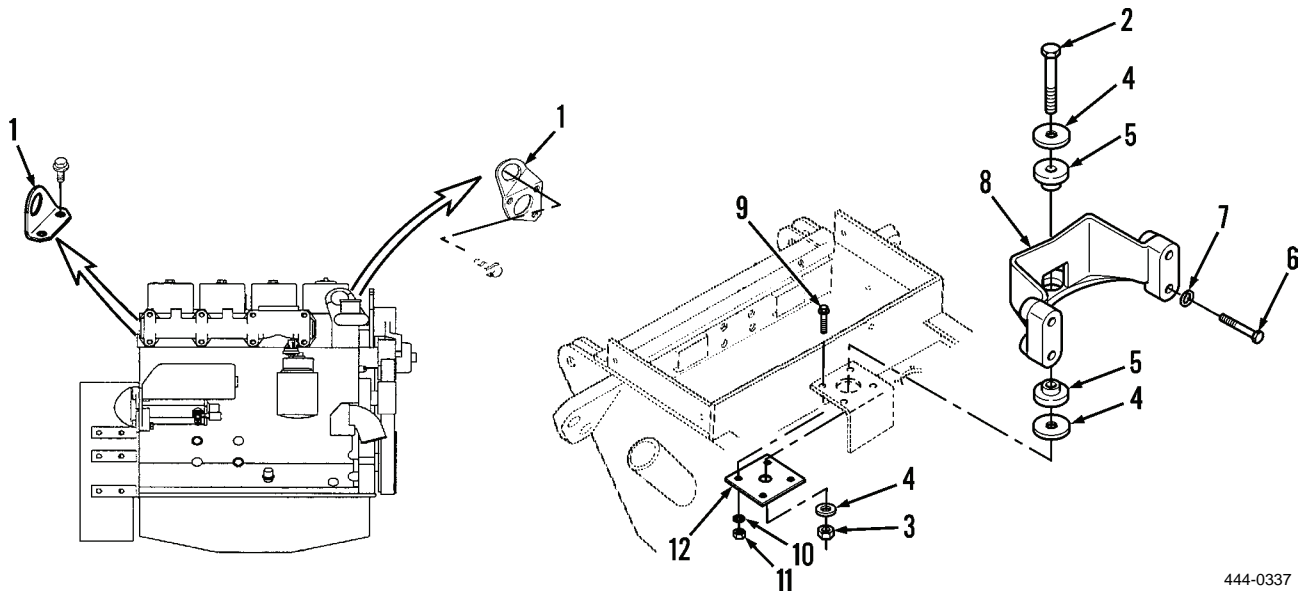

444-0337

**Figure 1. Engine Mount and Lifting Brackets.****END OF TASK**



**CLEANING****WARNING**

- Solvent cleaning compound MIL-PRF-680 Type III is an environmentally compliant and low toxic material. However, it may be irritating to the eyes and skin. Use protective gloves and goggles. Use in well-ventilated areas. Keep away from open flames and other sources of ignition. Failure to do so may result in injury or death to personnel.
  - Particles blown by compressed air are hazardous. DO NOT exceed 15 PSI (103 kPa) nozzle pressure when drying parts with compressed air. DO NOT direct compressed air against human skin. Make sure air stream is directed away from user and other personnel in the area. To prevent injury, user must wear protective goggles or face shield. Failure to follow this warning may result in injury to personnel.
1. Clean engine mount bracket, plate, and mounting hardware with solvent cleaning compound. Dry thoroughly with compressed air or clean rags.
  2. Clean rubber isolators by wiping with clean rags.

**END OF TASK****INSPECTION**

Inspect all parts. Replace if worn or damaged.

**END OF TASK****INSTALLATION**

1. Install plate (Figure 1, Item 12) on rear chassis with four capscrews (Figure 1, Item 9), washers (Figure 1, Item 10), and nuts (Figure 1, Item 11). Tighten capscrews to 110 to 132 lb-ft (149 to 179 Nm).
2. Install two isolators (Figure 1, Item 5) on engine mount bracket (Figure 1, Item 8).
3. Position engine mount bracket (Figure 1, Item 8) in engine compartment.
4. Install engine mount bracket (Figure 1, Item 8) on engine with four new lockwashers (Figure 1, Item 7) and capscrews (Figure 1, Item 6). Tighten capscrews to 320 to 380 lb-ft (434 to 515 Nm).
5. Install three washers (Figure 1, Item 4), nut (Figure 1, Item 3), and capscrew (Figure 1, Item 2). Tighten capscrew to 400 to 480 lb-ft (542 to 651 Nm).
6. Remove lifting equipment from both engine lifting brackets (Figure 1, Item 1).

**END OF TASK****END OF WORK PACKAGE**



# DIRECT SUPPORT MAINTENANCE INSTRUCTIONS

## POWER PACK REPLACEMENT (MODEL 207)

### Removal, Installation

#### INITIAL SETUP

##### Maintenance Level

Direct Support

##### Tools and Special Tools

Tool kit, general mechanic's (Item 15, WP 0309)  
 Shop equipment, common no. 1 (Item 2, WP 0309)  
 Drain pans  
 Sling and hoist, 1-ton capacity

##### Materials/Parts

Cleaning compound, solvent (Item 10, WP 0310)  
 Rag, wiping (Item 26, WP 0310)  
 Locknut (3)  
 Lockwasher (4)

##### Personnel Required

Two

##### References

WP 0209

##### Equipment Condition

**NOTE: Prepare equipment for power pack removal in the following order:**

##### Rear chassis, grille, and battery compartment:

Tow bar lowered and grille removed (WP 0177)  
 Battery ground cable disconnected (WP 0133)

##### Rear chassis, top and sides:

Left and right side panels removed (WP 0179)  
 Exhaust pipe removed (WP 0076)  
 Top hood removed (WP 0180)  
 Air cleaner removed (WP 0061)  
 Fenders removed (WP 0178)  
 Hood panels removed (WP 0182)

##### Rear chassis, front:

Front cover panel removed (WP 0184)  
 Hydraulic oil reservoir drained (WP 0198)

##### Engine compartment, rear:

Radiator and engine coolant drained (WP 0078)  
 Radiator hoses removed (WP 0080)  
 Oil cooler hoses disconnected from oil cooler (WP 0152)  
 Radiator shroud (with radiator and oil cooler still attached) removed (WP 0082)  
 Hydraulic oil reservoir removed (WP 0201)

##### Equipment Condition - Continued

##### Transmission, front:

Parking brake cable disconnected (WP 0161)  
 Center drive shaft assembly disconnected (WP 0155)

Rear drive shaft assembly disconnected (WP 0156)

##### Transmission, left side:

Neutral start switch and back-up alarm switch leads disconnected (WP 0118)

Transmission linkage cables disconnected (WP 0148)

Declutch valve outlet hose disconnected (WP 0167)

##### Engine, left side:

Alternator leads disconnected (WP 0093)

Battery cables, slave receptacle cables, and harness leads disconnected from starter and solenoid switch (WP 0095)

Starter relay and 25 amp circuit breaker leads disconnected (WP 0097)

Engine temperature switch lead disconnected (WP 0120)

##### Engine compartment, left side:

Hydraulic oil filter and filter head removed (WP 0199)

##### Engine compartment, right side:

Fuel tank shut-off valve closed

##### Transmission, right side:

Transmission temperature switch lead disconnected (WP 0121)

Oil cooler hoses disconnected (WP 0152)

Hydraulic pump hoses disconnected (WP 0172)

##### Engine, right side:

Fuel lines disconnected from fuel filters (WP 0059 and WP 0065)

Fuel return line disconnected from fuel injector tee fitting (WP 0063)

Restriction indicator and cold start kit lines disconnected from intake manifold (WP 0063 and WP 0073)

Accelerator ball joint and cable disconnected from fuel injection pump (WP 0074)

Muffler and muffler bracket removed (WP 0076)

Engine oil pressure switch and sending unit leads disconnected (WP 0123)

Rear axle breather removed (WP 0159)

**REMOVAL**

1. At engine compartment, attach sling and hoist to engine and transmission. Take up slack.
2. At transmission mounts (Figure 1, Item 15), remove two locknuts (Figure 1, Item 1), washers (Figure 1, Item 2), and capscrews (Figure 1, Item 3). Discard locknuts.

**NOTE**

- Washer (Figure 1, Item 6) can be removed from vehicle when power pack has been removed.
  - To replace rubber engine mount from rear engine mount, refer to WP 0209.
3. At rear engine mount (Figure 1, Item 12), remove locknut (Figure 1, Item 4), washer (Figure 1, Item 5), and washer (Figure 1, Item 6). Discard locknut.
  4. Remove capscrew (Figure 1, Item 7) and washer (Figure 1, Item 8) from rear engine mount (Figure 1, Item 12).
  5. At transmission, remove eight capscrews (Figure 1, Item 13), washers (Figure 1, Item 14), and two transmission mounts (Figure 1, Item 15).

**WARNING**

Keep clear of engine and transmission during power pack removal. Never place hands or body under power pack. Failure to do so may result in injury or death to personnel due to power pack falling.

**CAUTION**

Ensure all hoses, lines, and wires are disconnected as the power pack is lifted from vehicle. If necessary, lower power pack onto supports and disconnect remaining hoses, lines, or wires. Failure to do so may result in damage to equipment.

6. Slowly lift power pack from vehicle and place on suitable and secure supports.

**NOTE**

Perform step 7 if rear engine mount requires replacement.

7. Remove four nuts (Figure 1, Item 9), lockwashers (Figure 1, Item 10), capscrews (Figure 1, Item 11), and rear engine mount from engine. Discard lockwashers.

REMOVAL - CONTINUED

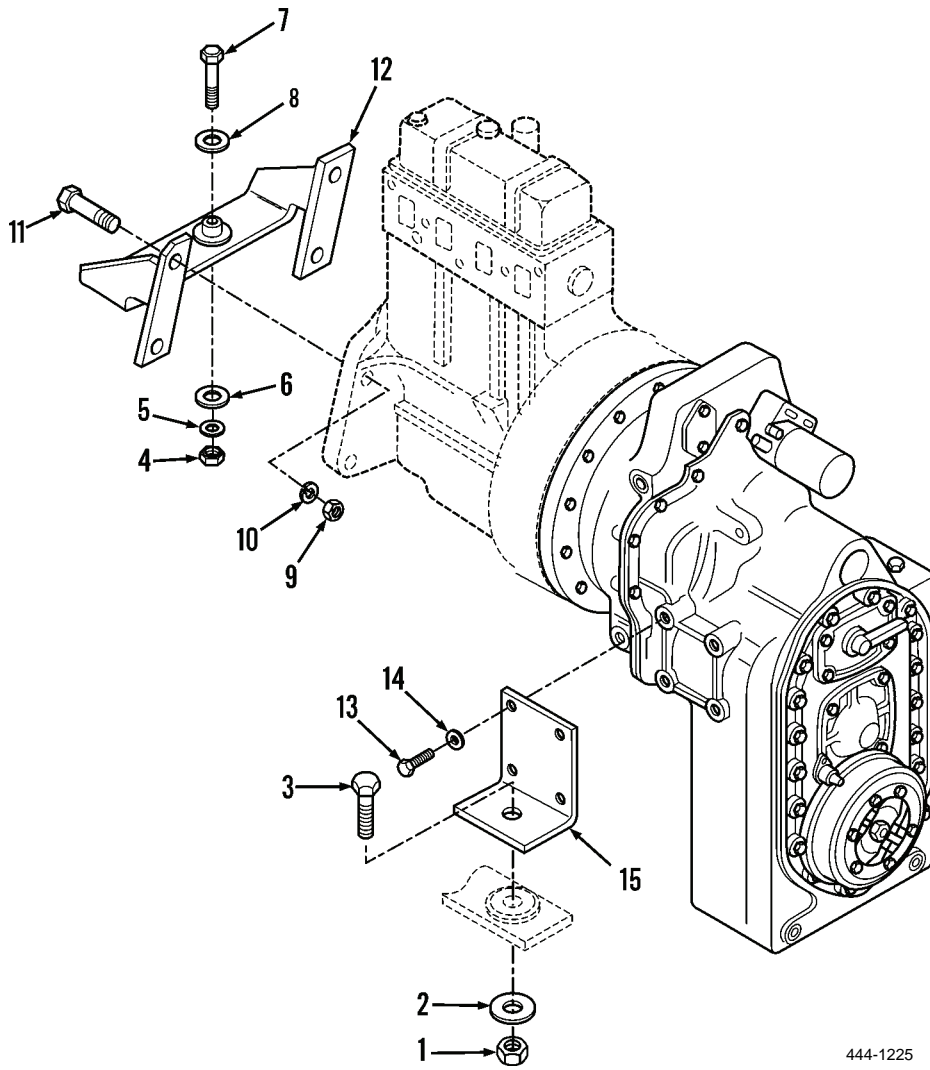

444-1225

Figure 1. Engine and Transmission Mounts.

END OF TASK

## INSTALLATION

### NOTE

Perform step 1 if rear engine mount required replacement.

1. Install rear engine mount (Figure 2, Item 12) on engine with four capscrews (Figure 2, Item 11), new lockwashers (Figure 2, Item 10), and nuts (Figure 2, Item 9). Tighten nuts to 150 to 180 lb-ft (203 to 244 Nm).



### WARNING

Keep clear of engine and transmission during power pack installation. Never place hands or body under power pack. Failure to do so may result in injury or death to personnel due to power pack falling.

### CAUTION

Ensure all hoses, lines, and wires are clear as power pack is slowly lowered into vehicle. If necessary, reposition hoses, lines, or wires before installing power pack. Failure to do so may result in damage to equipment.

2. Using slings and hoist, slowly lift power pack from secure location and slowly lower power pack into vehicle engine compartment.
3. At transmission, install two transmission mounts (Figure 2, Item 15) with eight washers (Figure 2, Item 14) and capscrews (Figure 2, Item 13).

### NOTE

Ensure washer (Figure 2, Item 6) is positioned between frame of vehicle and rear engine mount.

4. Position washer (Figure 2, Item 6), washer (Figure 2, Item 8), and capscrew (Figure 2, Item 7) on rear engine mount (Figure 2, Item 12).
5. Install washer (Figure 2, Item 5) and new locknut (Figure 2, Item 4) on capscrew (Figure 2, Item 7). Tighten locknut until bottom of rubber engine mount expands to same diameter as washer (Figure 2, Item 6).
6. At transmission, install two capscrews (Figure 2, Item 3), washers (Figure 2, Item 2), and new locknuts (Figure 2, Item 1). Tighten locknuts until bottom of rubber mounts expand to same diameter as washers.

INSTALLATION - CONTINUED

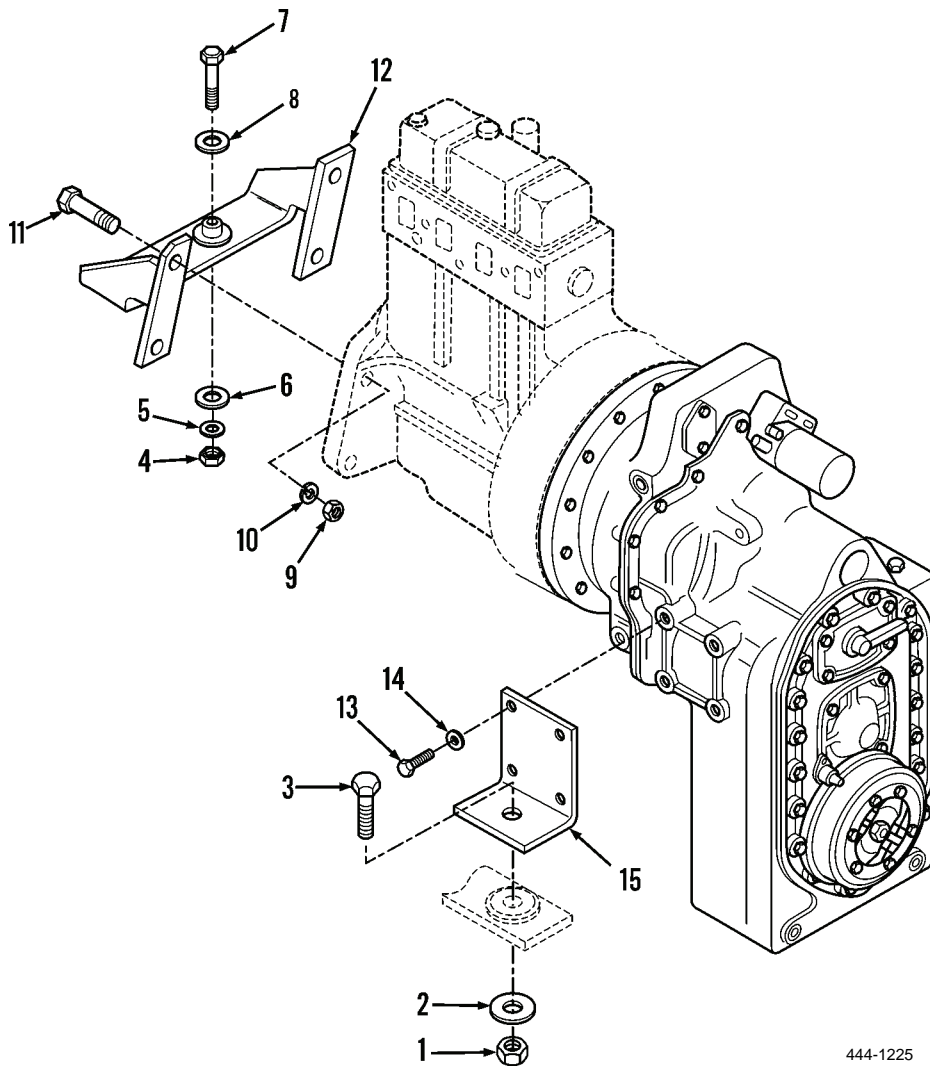

444-1225

Figure 2. Engine and Transmission Mounts.

END OF TASK

END OF WORK PACKAGE





## DIRECT SUPPORT MAINTENANCE INSTRUCTIONS

### POWER PACK REPLACEMENT (MODEL 4-390)

#### Removal, Installation

#### INITIAL SETUP

##### Maintenance Level

Direct Support

##### Tools and Special Tools

Tool kit, general mechanic's (Item 15, WP 0309)  
Shop equipment, common no. 1 (Item 2, WP 0309)  
Sling and hoist, 1-ton capacity

##### Materials/Parts

Cleaning compound, solvent (Item 10, WP 0310)  
Rag, wiping (Item 26, WP 0310)  
Drain pans

##### Personnel Required

Two

##### Equipment Condition

**NOTE: Prepare equipment for power pack removal in the following order:**

Tow bar lowered and grille removed (WP 0177)  
Battery ground cable disconnected (WP 0134)

##### Rear chassis, top and sides:

Left and right side panels removed (WP 0179)  
Exhaust pipe removed (WP 0077)  
Top hood removed (WP 0181)  
Air cleaner removed (WP 0062)  
Fenders removed (WP 0178)  
Hood panels removed (WP 0183)

##### Rear chassis, front:

Front cover panel removed (WP 0184)  
Hydraulic oil reservoir drained (WP 0198)

##### Engine compartment, rear:

Radiator and engine coolant drained (WP 0079)  
Radiator hoses removed (WP 0081)  
Oil cooler hoses disconnected from oil cooler (WP 0152)  
Radiator shroud (with radiator and oil cooler still attached) removed (WP 0083)  
Hydraulic oil reservoir removed (WP 0201)

##### Transmission, front:

Parking brake cable disconnected (WP 0161)  
Center drive shaft assembly disconnected (WP 0155)  
Rear drive shaft assembly disconnected (WP 0156)

##### Equipment Condition - Continued

##### Transmission, left side:

Neutral start switch and back-up alarm switch leads disconnected (WP 0119)  
Transmission linkage cables disconnected (WP 0148)  
Declutch valve outlet hose disconnected (WP 0167)

##### Engine, left side:

Alternator leads disconnected (WP 0094)  
Battery cables, slave receptacle cables, and harness leads disconnected from starter and solenoid switch (WP 0096)  
Starter relay and 25 amp circuit breaker leads disconnected (WP 0098)  
Engine temperature switch lead disconnected (WP 0122)

##### Engine compartment, left side:

Hydraulic oil filter and filter head removed (WP 0199)

##### Engine compartment, right side:

Fuel tank shut-off valve closed

##### Transmission, right side:

Transmission temperature switch lead disconnected (WP 0122)

Oil cooler hoses disconnected (WP 0152)

Hydraulic pump hoses disconnected (WP 0172)

##### Engine, right side:

Fuel lines disconnected from fuel filters (WP 0060 and WP 0066)

Fuel return line disconnected from fuel injector tee fitting (WP 0064)

Restriction indicator and cold start kit lines disconnected from intake manifold (WP 0064 and WP 0073)

Accelerator ball joint and cable disconnected from fuel injection pump (WP 0075)

Muffler and muffler bracket removed (WP 0077)

Engine oil pressure switch and sending unit leads disconnected (WP 0124)

Rear axle breather removed (WP 0159)

##### Engine compartment:

Engine mount removed (WP 0210)

Transmission mounts removed (WP 0214)

**REMOVAL**

1. In engine compartment, attach slings to engine and transmission and attach slings to lifting hoist.

**WARNING**

Keep clear of engine and transmission during power pack removal. Never place hands or body under power pack. Failure to do so may result in injury or death to personnel due to power pack falling.

**CAUTION**

Ensure all hoses, lines, and wires are disconnected as the power pack is lifted from vehicle. If necessary, lower power pack onto mounts and disconnect remaining hoses, lines, or wires. Failure to follow this caution could cause damage to equipment.

2. Slowly lift power pack from vehicle and place on suitable and secure supports.
3. If engine mount requires replacement (WP 0210).

**END OF TASK****INSTALLATION**

1. Install engine mount, if removed (WP 0210).

**WARNING**

Keep clear of engine and transmission during power pack installation. Never place hands or body under power pack. Failure to do so may result in injury or death to personnel due to power pack falling.

**CAUTION**

Ensure all hoses, lines, and wires are reconnected after power pack is installed in vehicle. Failure to follow this caution could cause damage to equipment.

2. Slowly lower power pack into vehicle. Ensure mounting holes are aligned.

**END OF TASK****END OF WORK PACKAGE**

---

## DIRECT SUPPORT MAINTENANCE INSTRUCTIONS

### SEPARATION OF ENGINE AND TRANSMISSION (MODEL 207)

#### Removal of Transmission from Engine, Installation of Transmission on Engine

---

##### INITIAL SETUP

**Maintenance Level**

Direct Support

**Tools and Special Tools**

Tool kit, general mechanic's (Item 15, WP 0309)

Guide stud, 3/8-24 NF x 4 in.

Sling and hoist, 1-ton capacity

**Materials/Parts**

Rag, wiping (Item 26, WP 0310)

Lockwasher (15)

**Personnel Required**

Two

**Equipment Condition**

Power pack removed from vehicle (WP 0211)

---

## REMOVAL OF TRANSMISSION FROM ENGINE

1. Fabricate and install transmission supports on transmission, as shown in Figure 1, to support transmission in upright position after removal from engine.
2. Remove three capscrews (Figure 1, Item 1), lockwashers (Figure 1, Item 2), washers (Figure 1, Item 3), and dust cover (Figure 1, Item 4) from engine flywheel housing.
3. Reach into engine flywheel housing opening and remove eight capscrews (Figure 1, Item 5) securing flex plate to flywheel. Rotate flywheel at crankshaft pulley as required to reach all eight capscrews. Hold crankshaft pulley, at front of engine, stationary (use 1/2-in. drive wrench) while removing capscrews.
4. Attach sling and hoist to transmission. Take up slack.
5. At flange of transmission, remove 10 capscrews (Figure 1, Item 7) and lockwashers (Figure 1, Item 8). Discard lockwashers.

### NOTE

Remove studs only if required for replacement.

6. Also at flange of transmission, remove two nuts (Figure 1, Item 6) and remaining lockwashers (Figure 1, Item 8) from studs (Figure 1, Item 9). Discard lockwashers.
7. Slide transmission rearward from flywheel housing until flex plate clears housing, then lift and remove transmission.

## END OF TASK

## INSTALLATION OF TRANSMISSION ON ENGINE

1. Install one guide stud in a lower flex plate nut and rotate flex plate until guide stud is at bottom center of transmission.
2. At engine flywheel housing, rotate flywheel until flex plate capscrew hole is aligned with guide stud at bottom of transmission.
3. If removed, install two studs (Figure 1, Item 9) on engine flywheel housing.
4. While aligning guide stud with flywheel, position transmission against engine flywheel housing.
5. Install two new lockwashers (Figure 1, Item 8) and nuts (Figure 1, Item 6) on studs (Figure 1, Item 9). Do not fully tighten nuts.
6. Install ten new lockwashers (Figure 1, Item 10) and capscrews (Figure 1, Item 7). Do not fully tighten capscrews.
7. Gradually rotate flywheel and flexplate and install at least one capscrew (Figure 1, Item 5) before removing guide stud. After all eight capscrews (Figure 1, Item 5) are snug, rotate flywheel and flex plate and tighten capscrews to 25 to 30 lb-ft (34 to 41 Nm).
8. Fully tighten two nuts (Figure 1, Item 6) and 10 capscrews (Figure 1, Item 7).
9. Install dust cover (Figure 1, Item 4) on engine flywheel housing with three washers (Figure 1, Item 3), new lockwashers (Figure 1, Item 2), and capscrews (Figure 1, Item 1).
10. Remove mounting hardware and transmission supports from transmission.

INSTALLATION OF TRANSMISSION ON ENGINE - CONTINUED

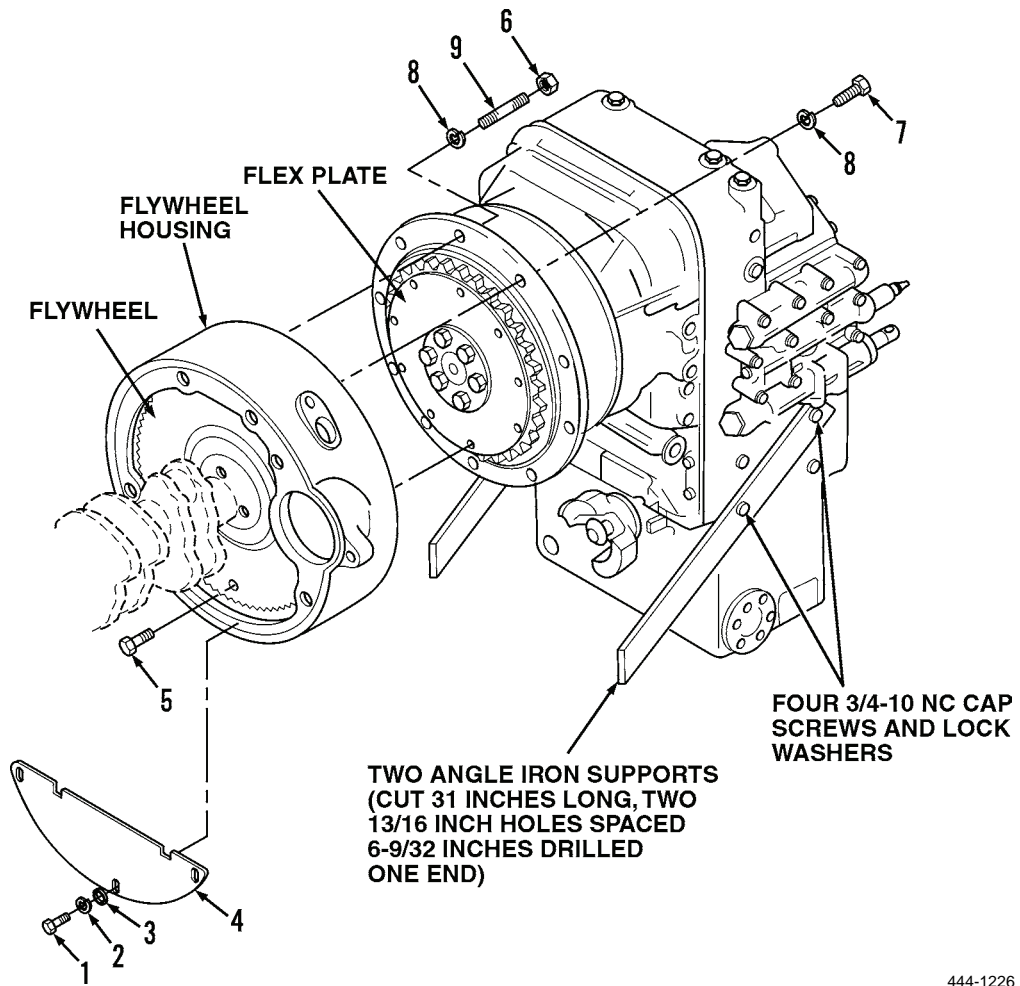

444-1226

Figure 1. Engine and Transmission.

END OF TASK

END OF WORK PACKAGE



## DIRECT SUPPORT MAINTENANCE INSTRUCTIONS

### SEPARATION OF ENGINE AND TRANSMISSION (MODEL 4-390)

#### Removal of Transmission from Engine, Installation of Transmission on Engine

#### INITIAL SETUP

##### Maintenance Level

Direct Support

##### Tools and Special Tools

Tool kit, general mechanic's (Item 15, WP 0309)

Guide stud, 3/8-24 NF x 4 in.

Sling and hoist, 1-ton capacity

##### Materials/Parts

Rag, wiping (Item 26, WP 0310)

Sealing compound, brown (Item 29, WP 0310)

Gasket

O-ring

##### Equipment Condition

Power pack removed from vehicle (WP 0212)

#### REMOVAL OF TRANSMISSION FROM ENGINE

1. Fabricate and install transmission supports on transmission, as shown in Figure 1, to support transmission in upright position after removal from engine.

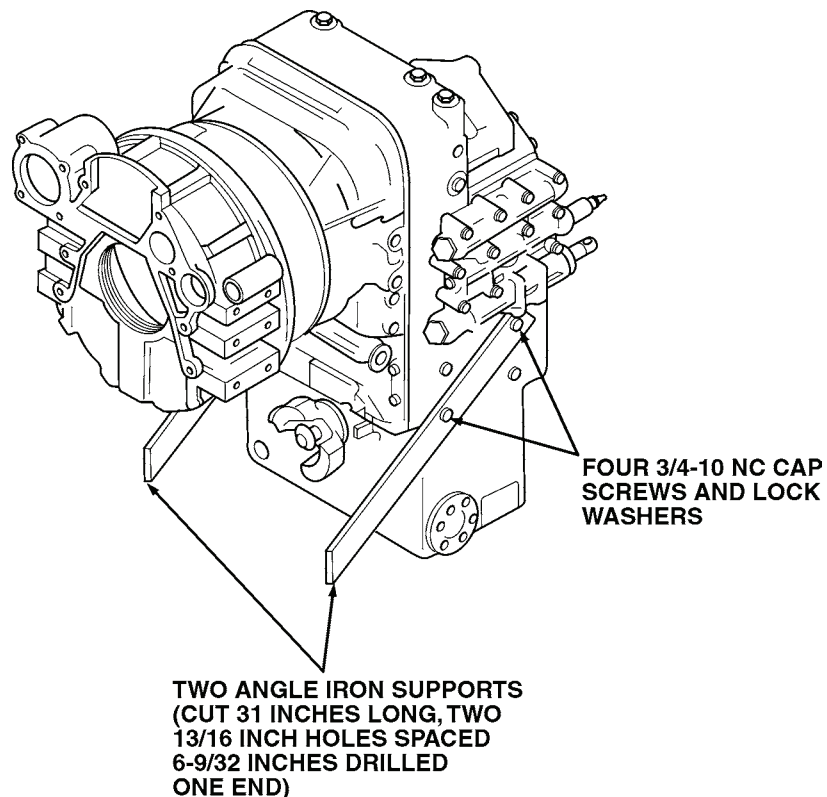
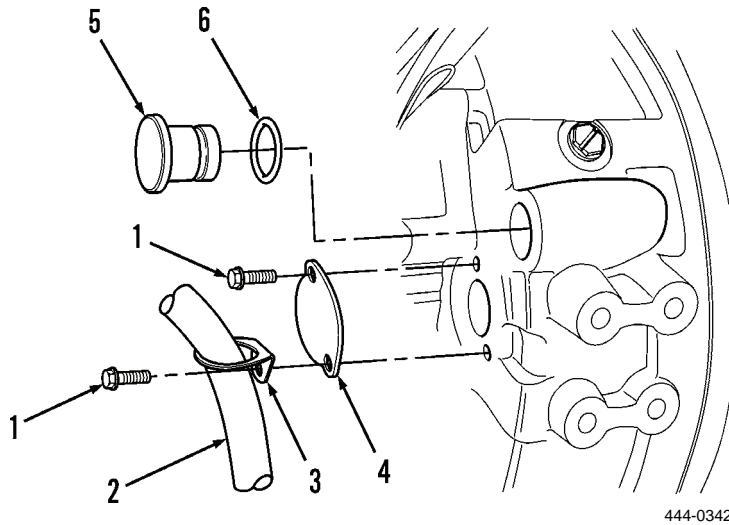

Figure 1. Transmission Supports.

**REMOVAL OF TRANSMISSION FROM ENGINE - CONTINUED**

2. Remove two capscrews (Figure 2, Item 1), hose (Figure 2, Item 2), hose bracket (Figure 2, Item 3), and flywheel housing inspection cover (Figure 2, Item 4) from engine flywheel housing.
3. Remove engine turnover access cover (Figure 2, Item 5) and O-ring (Figure 2, Item 6) from flywheel housing. Discard O-ring.

**Figure 2. Inspection Cover and Access Cover.**

4. Insert engine turnover tool into access hole (Figure 3). Rotate tool until a capscrew head is visible in inspection hole.

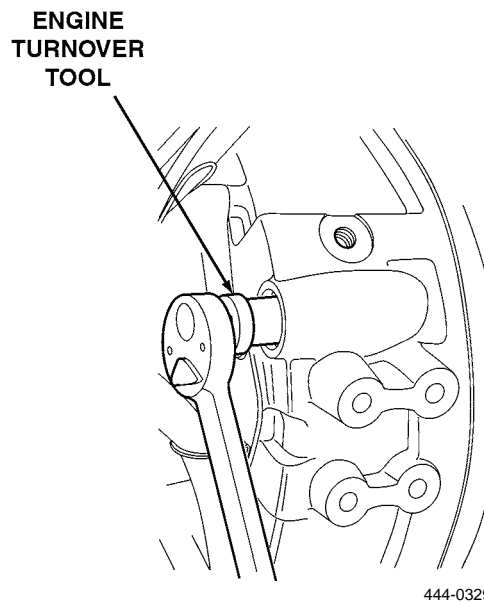
**Figure 3. Engine Turnover Tool.**



**REMOVAL OF TRANSMISSION FROM ENGINE - CONTINUED**

5. As tool is rotated, remove eight capscrews (Figure 4, Item 7) and lockwashers (Figure 4, Item 8), one at a time, from flywheel housing. Discard lockwashers.
6. Lower power pack so transmission is supported by ground.
7. Remove two nuts (Figure 4, Item 9) and lockwashers (Figure 4, Item 10) from flange of transmission. Discard lockwashers.
8. Remove 10 capscrews (Figure 4, Item 11) and lockwashers (Figure 4, Item 12). Discard lockwashers.
9. Carefully move hoist to separate engine from transmission.
10. Remove and discard gasket (Figure 4, Item 13).

**NOTE**

Remove two studs (Figure 4, Item 14) from flywheel housing only if replacement is necessary.

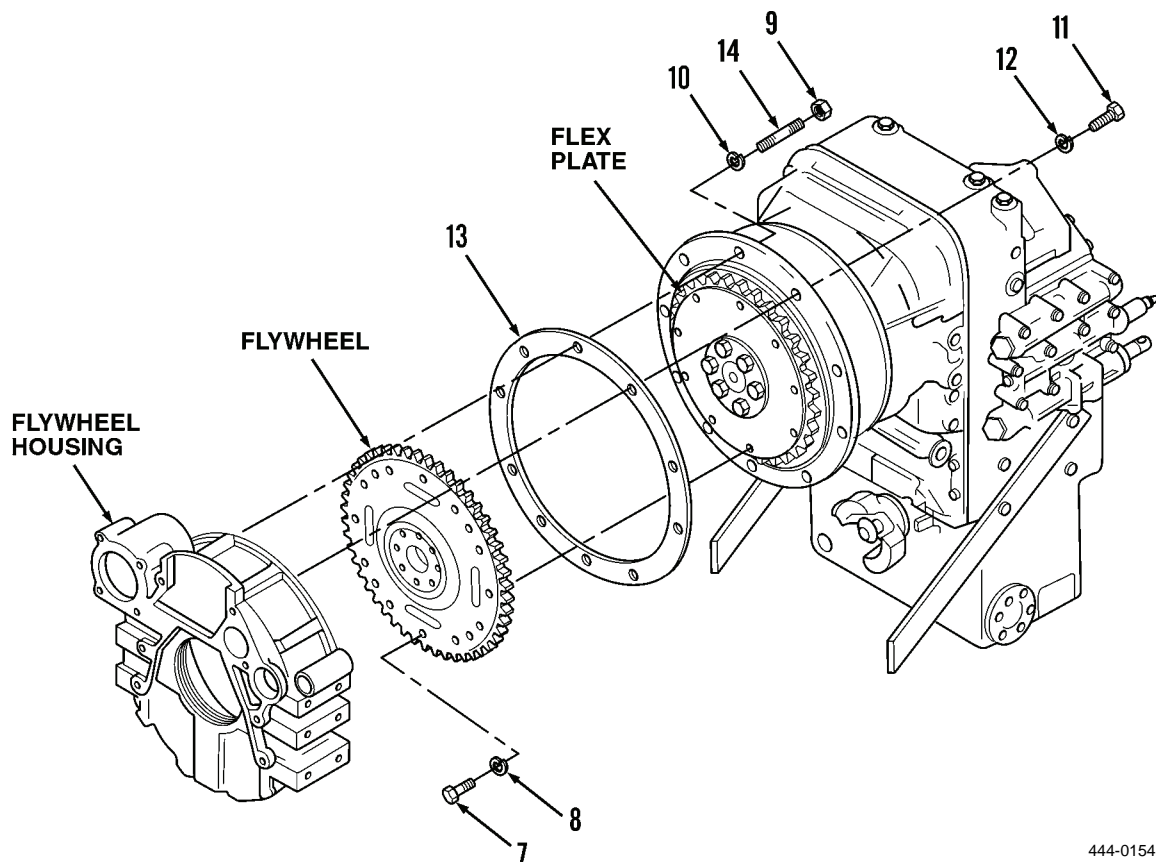

444-0154

**Figure 4. Engine and Transmission.**

**END OF TASK**

## INSTALLATION OF TRANSMISSION ON ENGINE

1. Install guide stud in flex plate.
2. Rotate flex plate until guide stud is at bottom center of transmission.
3. Install two studs (Figure 5, Item 14) in flywheel housing, if removed.
4. Position new gasket (Figure 5, Item 13) on transmission.
5. Carefully move hoist to position engine against transmission. Align guide stud with one hole in flywheel. Align two studs (Figure 5, Item 14) with holes in transmission housing.
6. Install two new lockwashers (Figure 5, Item 10) and nuts (Figure 5, Item 9) on studs (Figure 5, Item 14).
7. Install 10 new lockwashers (Figure 5, Item 12) and capscrews (Figure 5, Item 11).
8. While using engine turnover tool to rotate flywheel, install one (or more) new lockwashers (Figure 5, Item 8) and capscrews (Figure 5, Item 7) in flywheel.
9. Remove guide stud.
10. Install remaining new lockwashers (Figure 5, Item 8) and capscrews (Figure 5, Item 7). Tighten all eight capscrews to 25 to 30 lb-ft (34 to 41 Nm).

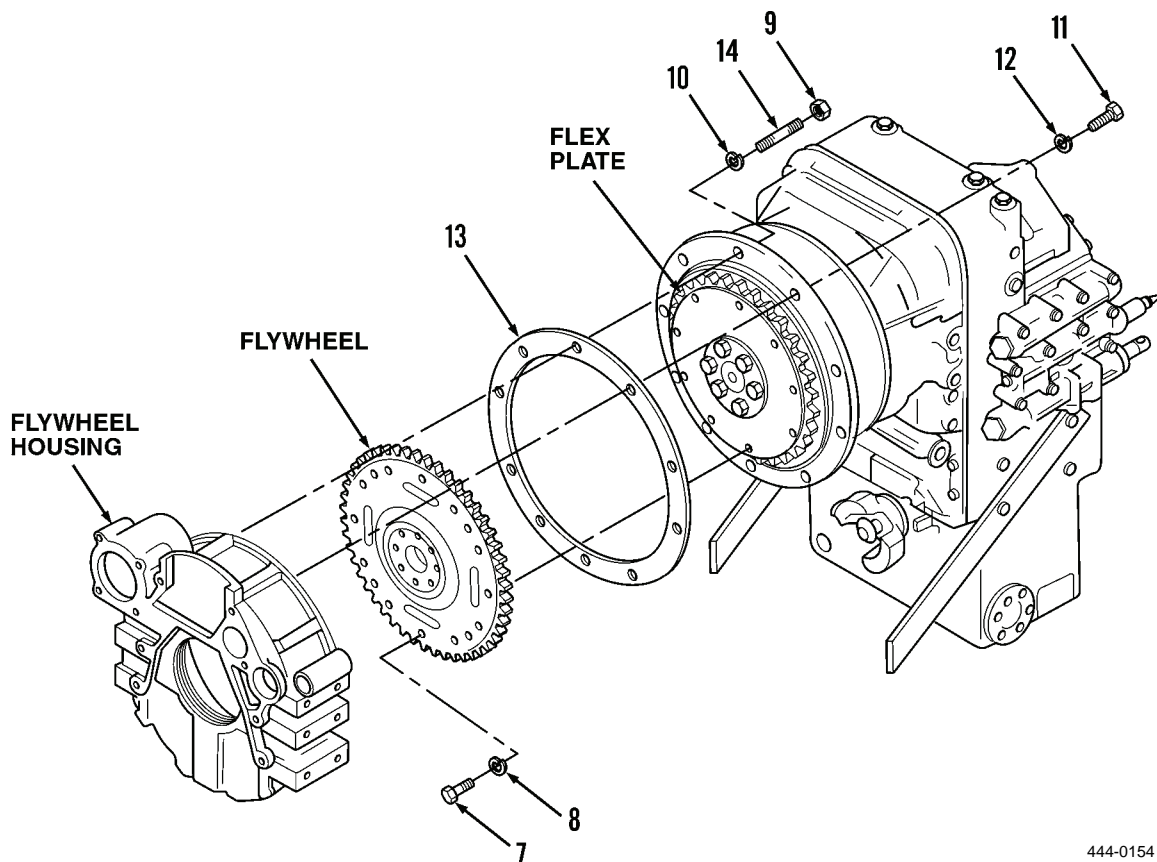

444-0154

Figure 5. Engine and Transmission.

**INSTALLATION OF TRANSMISSION ON ENGINE - CONTINUED**

11. Remove engine turnover tool from access hole.
12. Install new O-ring (Figure 6, Item 6) and engine turnover access cover (Figure 6, Item 5).
13. Install flywheel housing inspection cover (Figure 6, Item 4), hose bracket (Figure 6, Item 3), and hose (Figure 6, Item 2) with two capscrews (Figure 6, Item 1).

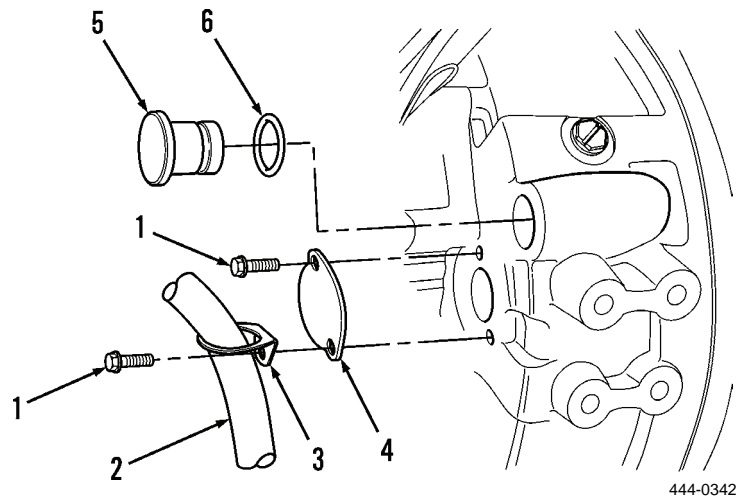

**Figure 6. Inspection Cover and Access Cover.**

14. Remove mounting hardware and transmission supports from transmission.

**END OF TASK**

**END OF WORK PACKAGE**



# DIRECT SUPPORT MAINTENANCE INSTRUCTIONS

## CYLINDER BLOCK INSPECTION (MODEL 207)

### Inspection

#### INITIAL SETUP

##### Maintenance Level

Direct Support

##### Tools and Special Tools

Tool kit, general mechanic's (Item 15, WP 0309)

##### Materials/Parts

Rag, wiping (Item 26, WP 0310)

##### Equipment Condition

Vehicle parked on level surface

Engine OFF

Parking brake applied

Left and right side panels removed (WP 0179)

#### INSPECTION

At engine compartment, inspect cylinder block (Figure 1). If any expansion plugs are eroded or leaking, cylinder block is cracked, or shows sign of damage or wear, notify General Support Maintenance.

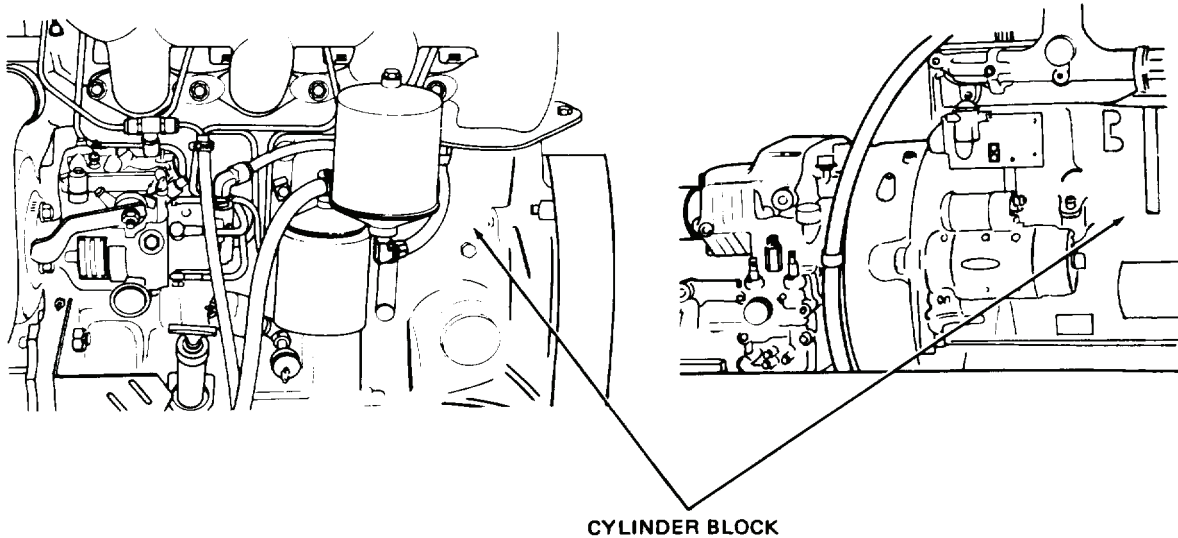

TA127102

Figure 1. Cylinder Block Inspection.

END OF TASK

END OF WORK PACKAGE



---

## DIRECT SUPPORT MAINTENANCE INSTRUCTIONS

### CYLINDER BLOCK INSPECTION (MODEL 4-390)

#### Inspection

---

#### INITIAL SETUP

**Maintenance Level**

Direct Support

**Tools and Special Tools**

Tool kit, general mechanic's (Item 15, WP 0309)

**Materials/Parts**

Rag, wiping (Item 26, WP 0310)

**Equipment Condition**

Vehicle parked on level surface

Engine OFF

Parking brake applied

Left and right side panels removed (WP 0179)

---

#### INSPECTION

In engine compartment, inspect cylinder block. Notify General Support Maintenance if an expansion plug is eroded, or if cylinder block is cracked, leaking, or damaged.

#### END OF TASK

#### END OF WORK PACKAGE





---

## DIRECT SUPPORT MAINTENANCE INSTRUCTIONS

### TACHOMETER DRIVE REPLACEMENT (MODEL 207)

Removal, Cleaning, Inspection, Installation

---

#### INITIAL SETUP

**Maintenance Level**

Direct Support

**Tools and Special Tools**

Tool kit, general mechanic's (Item 15, WP 0309)

Tachometer drive removal tool

**Materials/Parts**

Cleaning compound, solvent (Item 10, WP 0310)

**Materials/Parts - Continued**

Rag, wiping (Item 26, WP 0310)

**Equipment Condition**

Vehicle parked on level surface

Engine OFF

Parking brake applied

Left side panel removed (WP 0179)

---

REMOVAL

NOTE

Fabricate tachometer drive removal tool as shown in Figure 1.

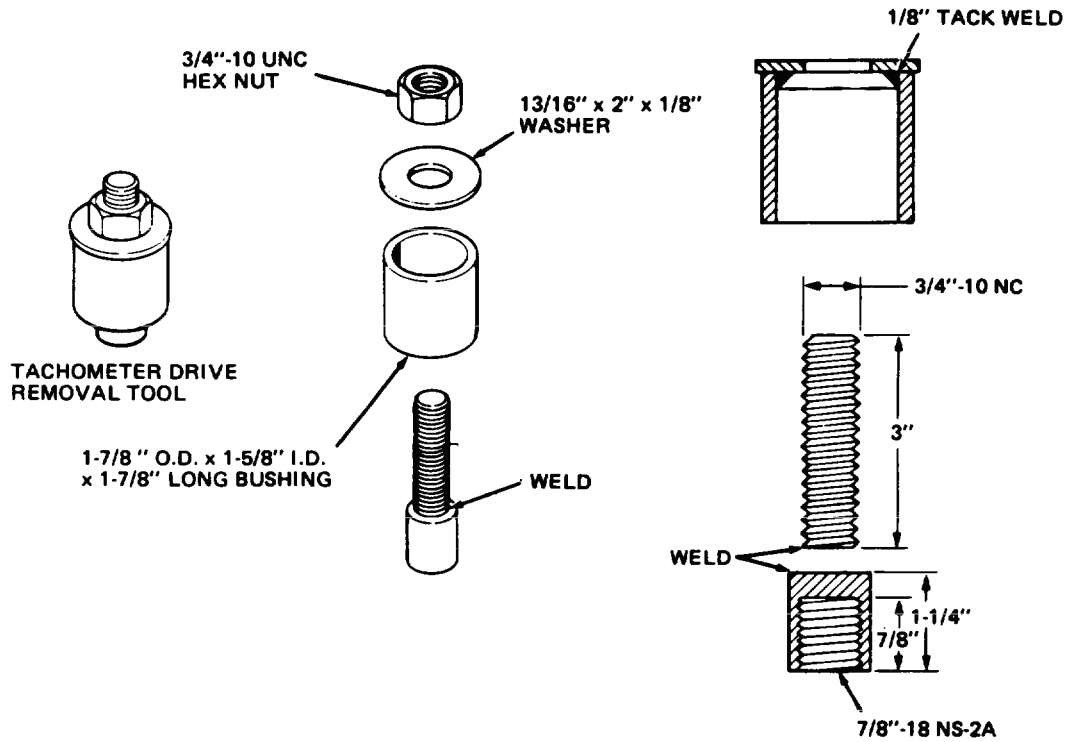

TA127103

Figure 1. Removal Tool.

**REMOVAL - CONTINUED**

1. At left side of engine compartment, rotate tachometer drive cover counterclockwise and lift tachometer drive cover from tachometer drive.
2. Install tachometer drive removal tool on threads of tachometer drive (Figure 2).
3. Rotate nut of tachometer drive removal tool clockwise to remove tachometer drive from engine.
4. Remove tachometer drive removal tool from tachometer drive.

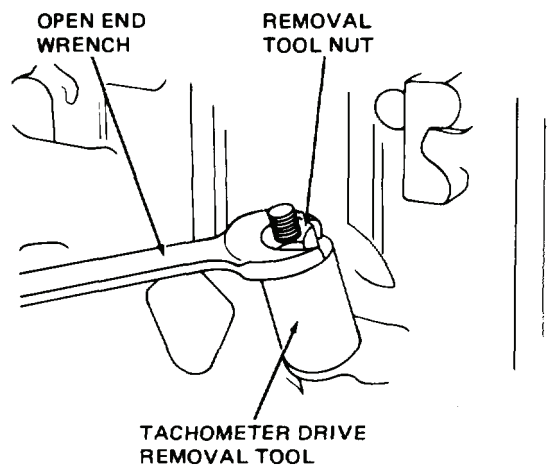

TA127104

**Figure 2. Removal of Tachometer Drive.****END OF TASK****CLEANING****WARNING**

- Solvent cleaning compound MIL-PRF-680 Type III is an environmentally compliant and low toxic material. However, it may be irritating to the eyes and skin. Use protective gloves and goggles. Use in well-ventilated areas. Keep away from open flames and other sources of ignition. Failure to do so may result in injury or death to personnel.
- Particles blown by compressed air are hazardous. **DO NOT** exceed 15 PSI (103 kPa) nozzle pressure when drying parts with compressed air. **DO NOT** direct compressed air against human skin. Make sure air stream is directed away from user and other personnel in the area. To prevent injury, user must wear protective goggles or face shield. Failure to follow this warning may result in injury to personnel.

Clean tachometer drive with solvent cleaning compound. Dry with compressed air.

**END OF TASK**

**INSPECTION**

Inspect tachometer drive. Replace if body is cracked or threads are damaged, drive gear teeth are worn or broken, or if drive shaft or bushings are excessively worn.

**END OF TASK****INSTALLATION**

1. At left side of engine compartment, position tachometer drive in engine block.
2. Carefully tap tachometer drive with soft-faced hammer until top of body is flush with engine block.
3. Install tachometer drive cover. Turn clockwise on tachometer drive threads until hand-tight.

**END OF TASK****END OF WORK PACKAGE**

---

## DIRECT SUPPORT MAINTENANCE INSTRUCTIONS

### CYLINDER HEAD REPLACEMENT (MODEL 207)

#### Removal, Inspection, Installation

---

#### INITIAL SETUP

##### Maintenance Level

Direct Support

##### Tools and Special Tools

Tool kit, general mechanic's (Item 15, WP 0309)  
Shop equipment, common no. 1 (Item 2, WP 0309)  
Extension wrench (P/N M20419)

##### Materials/Parts

Cleaning compound, solvent (Item 10, WP 0310)  
Lubricating oil, OE/HDO-15/40 (Item 21, WP 0310)  
Rag, wiping (Item 26, WP 0310)  
Gasket

##### References

WP 0213  
WP 0270  
WP 0272

##### References - Continued

WP 0280

##### Equipment Condition

Vehicle parked on level surface  
Engine OFF  
Parking brake applied  
Left and right side panels removed (WP 0179)  
Top hood removed (WP 0180)  
Spark arresting muffler removed (WP 0076)  
Intake manifold removed (WP 0053)  
Exhaust manifold removed (WP 0055)  
Water pump removed (WP 0086)  
Engine temperature switch removed (WP 0120)  
Rocker arm cover removed (WP 0222)  
Rocker arm assembly removed (WP 0224)  
Fuel injectors removed (WP 0231)

---

**REMOVAL**

1. At top of engine cylinder head (Figure 1, Item 4), loosen two stud nuts (Figure 1, Item 1).
2. Remove two stud nuts (Figure 1, Item 1) and rocker arm cover studs (Figure 1, Item 6) as two assemblies. Remove two washers (Figure 1, Item 3). Separate stud nuts from studs only if required for replacement.
3. Remove 17 bolts (Figure 1, Item 2) and 17 additional washers (Figure 1, Item 3) from top of cylinder head (Figure 1, Item 4).
4. Remove cylinder head (Figure 1, Item 4) and gasket (Figure 1, Item 5) from engine block. Discard gasket.
5. Clean any remaining gasket material from cylinder head (Figure 1, Item 4) and engine block.

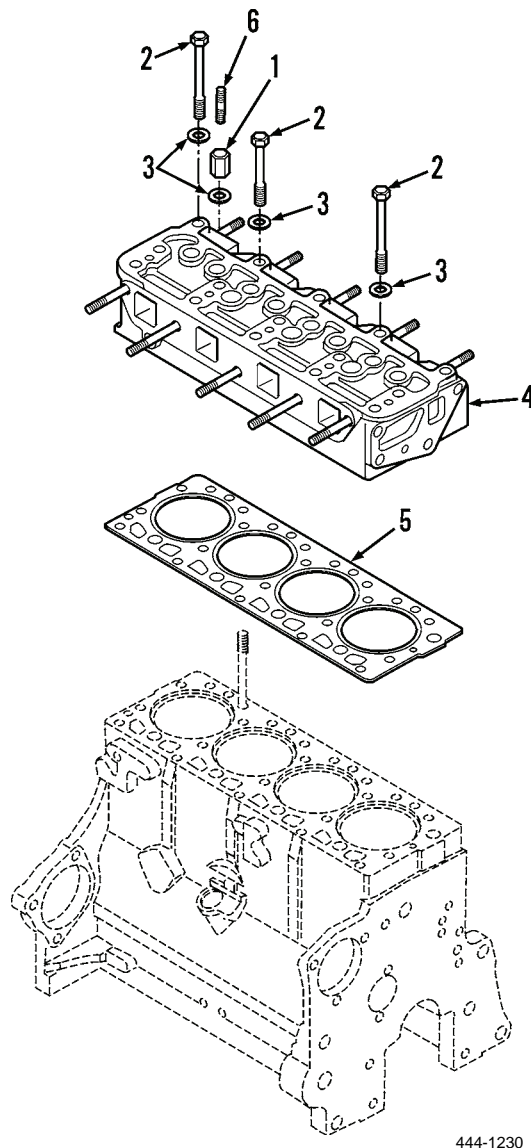
**Figure 1. Engine Cylinder Head.****END OF TASK**

## INSPECTION

1. Inspect cylinder head. Replace if cracked or damaged.
2. Inspect bottom surface of cylinder head for warpage. Lay a straightedge diagonally from corner to corner and try to slide a 0.006 in. (0.152 mm) feeler gage under straightedge. Check at several points. Position straightedge at opposite corners and repeat checks. Resurface cylinder head if warpage exceeds 0.006 in. (WP 0272).
3. Inspect nuts, bolts, washers, and studs. Replace if corroded, worn, stretched, or threads are damaged.
4. Inspect walls of cylinder block sleeves. Check taper and out-of-roundness with bore gage. Replace sleeves if taper is more than 0.002 in. (0.051 mm) or if out-of-roundness is more than 0.001 in. (0.025 mm) (WP 0270).
5. Inspect tops of pistons. Replace if cracked or damaged (WP 0280).
6. Inspect top surface of engine cylinder block. Measure top surface using straightedge and feeler gage. Replace engine cylinder block if top varies more than 0.002 in. (0.051 mm) or if block is cracked, eroded, or damaged (WP 0213).

## END OF TASK

## INSTALLATION

1. Position new gasket (Figure 2, Item 5) on top of engine cylinder block. Ensure water hole of gasket aligns with water hole at fan end of block.

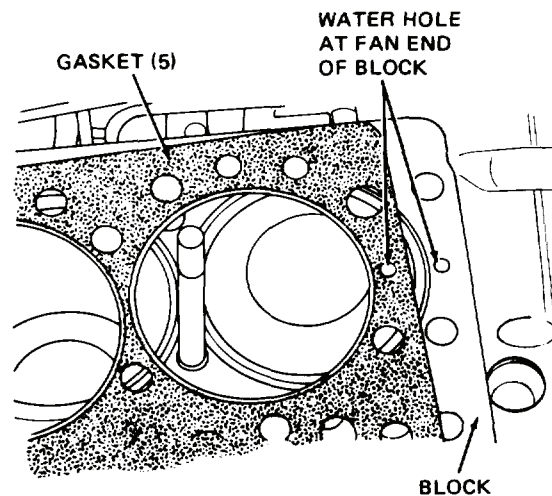

TA127106

Figure 2. Cylinder Head Gasket.

**INSTALLATION - CONTINUED**

2. Position cylinder head (Figure 3, Item 4) on engine cylinder block.
3. Apply thin coat of lubricating oil to two nuts (Figure 3, Item 1), rocker arm cover studs (Figure 3, Item 6), and 17 bolts (Figure 3, Item 2).
4. Install two washers (Figure 3, Item 3) and rocker arm stud (Figure 3, Item 6) and nut (Figure 3, Item 1) assemblies to top of cylinder head (Figure 3, Item 4).
5. Install 17 additional washers (Figure 3, Item 3) and bolts (Figure 3, Item 2).

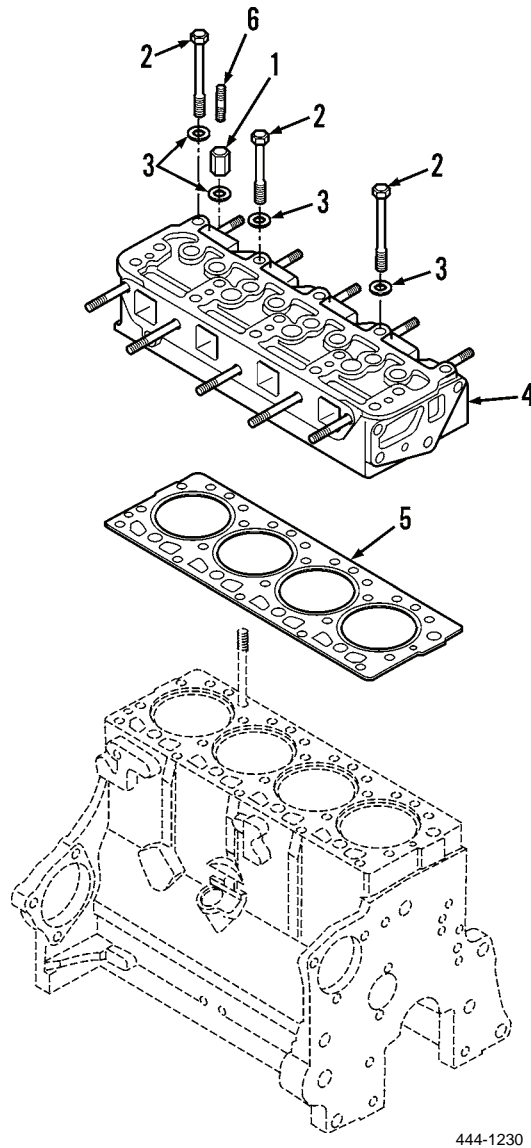
**Figure 3. Engine Cylinder Head.**



**INSTALLATION - CONTINUED****NOTE**

In steps 6 and 7, use extension wrench to torque nuts located at positions 4 and 5 (Figure 4).

6. Tighten two nuts (Figure 3, Item 1) and 17 bolts (Figure 3, Item 2) to 55 lb-ft (75 Nm) in sequence shown (Figure 4).
7. Using same tightening sequence (Figure 4), tighten two nuts (Figure 3, Item 1) and 17 bolts (Figure 3, Item 2) to 110 to 115 lb-ft (149 to 156 Nm).

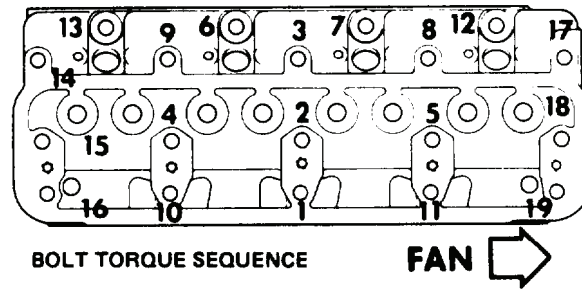

TA127090

**Figure 4. Bolt Tightening Sequence.**

**END OF TASK**

**END OF WORK PACKAGE**



---

## DIRECT SUPPORT MAINTENANCE INSTRUCTIONS

### CYLINDER HEAD REPLACEMENT (MODEL 4-390)

#### Removal, Inspection, Installation

---

#### INITIAL SETUP

##### Maintenance Level

Direct Support

##### Tools and Special Tools

Tool kit, general mechanic's (Item 15, WP 0309)  
 Shop equipment, common no. 1 (Item 2, WP 0309)  
 Extension wrench (P/N M20419)

##### Materials/Parts

Lubricating oil, OE/HDO-15/40 (Item 21, WP 0310)  
 Rag, wiping (Item 26, WP 0310)  
 Gasket

##### Equipment Condition

Vehicle parked on level surface  
 Engine OFF

##### Equipment Condition - Continued

Parking brake applied  
 Left and right side panels removed (WP 0179)  
 Top hood removed (WP 0181)  
 Spark arresting muffler removed (WP 0077)  
 Intake manifold removed (WP 0054)  
 Exhaust manifold removed (WP 0056)  
 Water pump removed (WP 0087)  
 Engine temperature switch removed (WP 0122)  
 Fuel injection lines and fittings removed (WP 0230)  
 Rocker arm cover removed (WP 0223)  
 Rocker arm assembly removed (WP 0223)  
 Fuel injectors removed (WP 0232)

---

**REMOVAL**

1. At top of cylinder head (Figure 1, Item 2), remove ten bolts (Figure 1, Item 1).
2. Lift cylinder head (Figure 1, Item 2) from engine block.
3. Remove gasket (Figure 1, Item 3) from cylinder head (Figure 1, Item 2) or from engine block. Discard gasket. Clean all gasket residue from cylinder head and engine block.

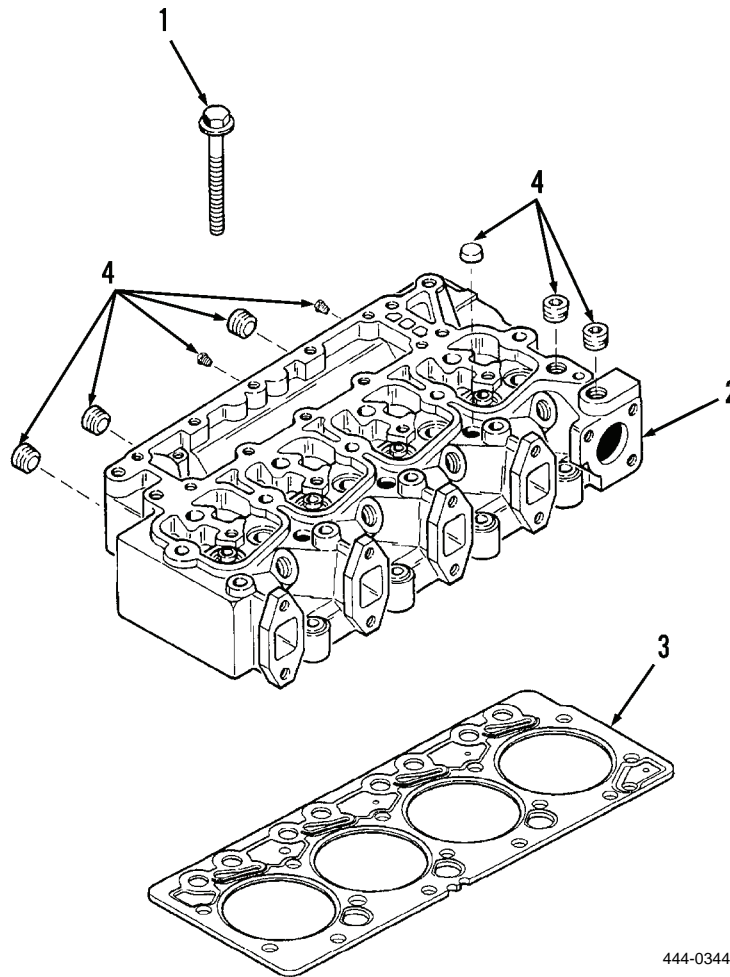

444-0344

**Figure 1. Engine Cylinder Head.****END OF TASK**

**INSPECTION**

1. Inspect bolts (Figure 1, Item 1). Replace if worn, or if threads are damaged.
2. Inspect tops of pistons. Replace if cracked or damaged. Clean carbon deposits (notify General Support Maintenance).
3. Inspect cylinder block sleeves for scoring. Replace if scored (notify General Support Maintenance).
4. Inspect cylinder block sleeves for taper. Check taper and out-of-roundness with bore gage. Replace sleeves if taper is more than 0.002 in. (0.051 mm) or if out-of-roundness is more than 0.001 in. (0.025 mm) (notify General Support Maintenance).
5. Inspect cylinder block top surface. Measure top surface using straightedge and feeler gage. Replace cylinder block if top surface varies more than 0.002 in. (0.051 mm), or if cylinder block is cracked, damaged, or eroded (notify General Support Maintenance).
6. Inspect cylinder head (Figure 1, Item 2). Replace if plugs are eroded, head is cracked, or valves are burned or damaged.
7. Inspect cylinder head bottom surface for warp. Lay straightedge diagonally from corner to corner and try to get a 0.030 in. (0.76 mm) feeler gage under straightedge. Check at several points. Reposition straightedge at opposite corners and repeat checks. Resurface cylinder head if warp exceeds 0.030 in. (0.76 mm) (notify General Support Maintenance).

**END OF TASK**

**INSTALLATION**

1. Position new gasket (Figure 1, Item 3) on top of engine cylinder block.
2. Position cylinder head (Figure 1, Item 2) over cylinder block and studs, and lower onto aligning dowels until resting on cylinder block.
3. Apply thin coat of lubricating oil to 10 bolts (Figure 1, Item 1).
4. Install 10 bolts (Figure 1, Item 1) on cylinder head (Figure 1, Item 2).

**NOTE**

Final torquing of all 18 bolts will be performed when rocker arm assemblies are installed.

5. Tighten 10 bolts to 30 lb-ft (41 Nm) in sequence shown in Figure 2.

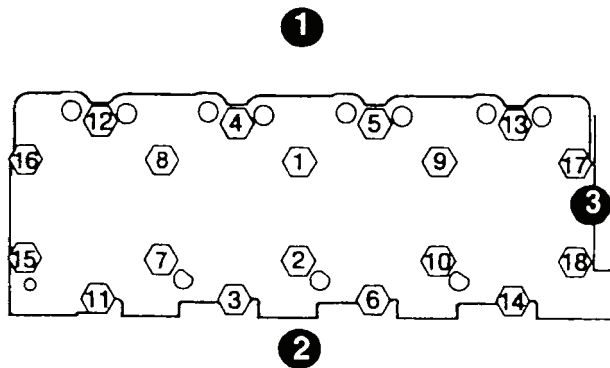

1. Intake Side    2. Exhaust Side    3. Front

444-0345

**Figure 2. Bolt Tightening Sequence.**

**END OF TASK**

**END OF WORK PACKAGE**



---

## DIRECT SUPPORT MAINTENANCE INSTRUCTIONS

### FLYWHEEL HOUSING INSPECTION (MODEL 207)

#### Inspection

---

#### INITIAL SETUP

**Maintenance Level**

Direct Support

**Tools and Special Tools**

Tool kit, general mechanic's (Item 15, WP 0309)

**Materials/Parts**

Rag, wiping (Item 26, WP 0310)

Lockwasher (4)

**References**

WP 0278

**Equipment Condition**

Vehicle parked on level surface

Engine OFF

Parking brake applied

Left and right side panels removed (WP 0179)

**INSPECTION**

1. In engine compartment, loosen capscrew (Figure 1, Item 1) of engine flywheel housing (Figure 1, Item 6) and move cover (Figure 1, Item 5) aside.
2. Inspect condition of cover (Figure 1, Item 5), capscrew (Figure 1, Item 1), and lockwasher (Figure 1, Item 2). Replace damaged or missing parts (WP 0278).
3. If parts are okay, close cover (Figure 1, Item 5) and tighten capscrew (Figure 1, Item 1).
4. Loosen three capscrews (Figure 1, Item 1) and inspect condition of dust cover (Figure 1, Item 4), three capscrews, lockwashers (Figure 1, Item 2), and washers (Figure 1, Item 3). Replace damaged or missing parts (WP 0278).
5. If parts are okay, tighten three capscrews (Figure 1, Item 1).
6. Inspect engine flywheel housing (Figure 1, Item 6). Replace if cracked or damaged (WP 0278).

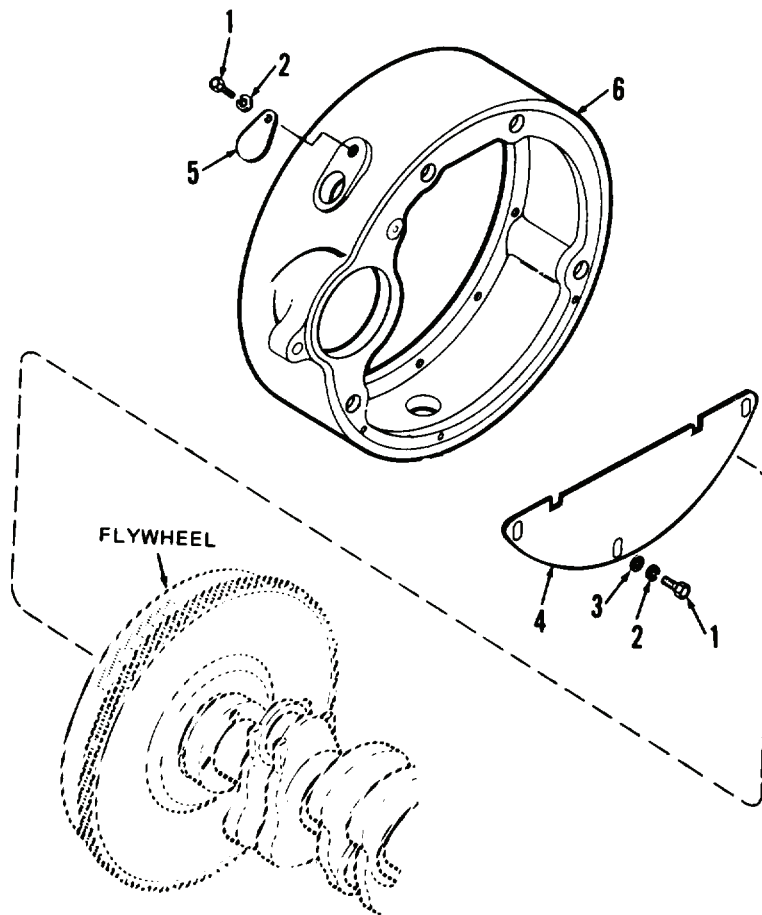

TA127107

**Figure 1. Engine Flywheel Housing.****END OF TASK****END OF WORK PACKAGE**



# DIRECT SUPPORT MAINTENANCE INSTRUCTIONS

## FLYWHEEL HOUSING INSPECTION (MODEL 4-390)

### Inspection

#### INITIAL SETUP

##### Maintenance Level

Direct Support

##### Tools and Special Tools

Tool kit, general mechanic's (Item 15, WP 0309)

##### Materials/Parts

Rag, wiping (Item 26, WP 0310)

##### Equipment Conditions

Vehicle parked on level surface

Engine OFF

Parking brake applied

Left and right side panels removed (WP 0179)

#### INSPECTION

1. At engine flywheel housing (Figure 1, Item 8), remove and inspect access cover (Figure 1, Item 1) and O-ring (Figure 1, Item 2). Replace if damaged. Install access cover and O-ring.
2. Inspect two capscrews (Figure 1, Item 3), hose (Figure 1, Item 4), hose bracket (Figure 1, Item 5), and inspection cover (Figure 1, Item 6). Replace if damaged.
3. Remove and inspect plug (Figure 1, Item 7). Replace if damaged. Install plug.
4. Inspect flywheel housing (Figure 1, Item 8). Notify General Support Maintenance if cracked or damaged.

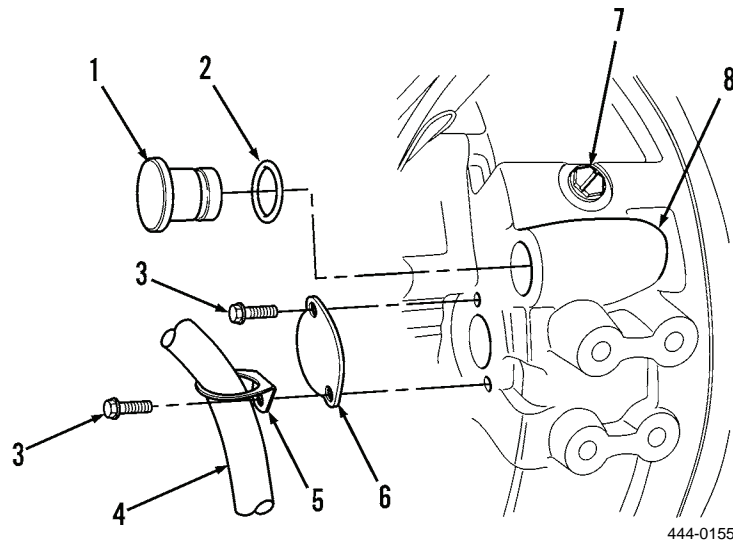

Figure 1. Inspection Cover and Access Cover.

END OF TASK

END OF WORK PACKAGE



---

## DIRECT SUPPORT MAINTENANCE INSTRUCTIONS

### ROCKER ARM COVER MAINTENANCE (MODEL 207)

Removal, Cleaning, Inspection, Repair, Installation

---

#### INITIAL SETUP

**Maintenance Level**

Direct Support

**Tools and Special Tools**

Tool kit, general mechanic's (Item 15, WP 0309)

**Materials/Parts**

Cleaning compound, solvent (Item 10, WP 0310)

Rag, wiping (Item 26, WP 0310)

Gasket

**Materials/Parts - Continued**

Hose, 44 ± 0.5 in. long

(P/N IFBRBRDLPBLKSYNRBRHYDHSE3-4ID)

**Equipment Condition**

Vehicle parked on level surface

Engine OFF

Parking brake applied

Top hood removed (WP 0180)

---

**REMOVAL**

1. In engine compartment, loosen hose clamp (Figure 1, Item 1) and disconnect breather hose (Figure 1, Item 2) from breather elbow (Figure 1, Item 8) of rocker arm cover (Figure 1, Item 6).
2. Remove hose clamp (Figure 1, Item 1) from breather hose (Figure 1, Item 2).
3. Remove two nuts (Figure 1, Item 3), washers (Figure 1, Item 4), and grommets (Figure 1, Item 5) from top of rocker arm cover (Figure 1, Item 6).
4. Remove rocker arm cover (Figure 1, Item 6) and gasket (Figure 1, Item 7) from engine cylinder head. Discard gasket.
5. Remove breather elbow (Figure 1, Item 8) and decal (Figure 1, Item 9), if necessary, from rocker arm cover (Figure 1, Item 6). Discard decal if removed.

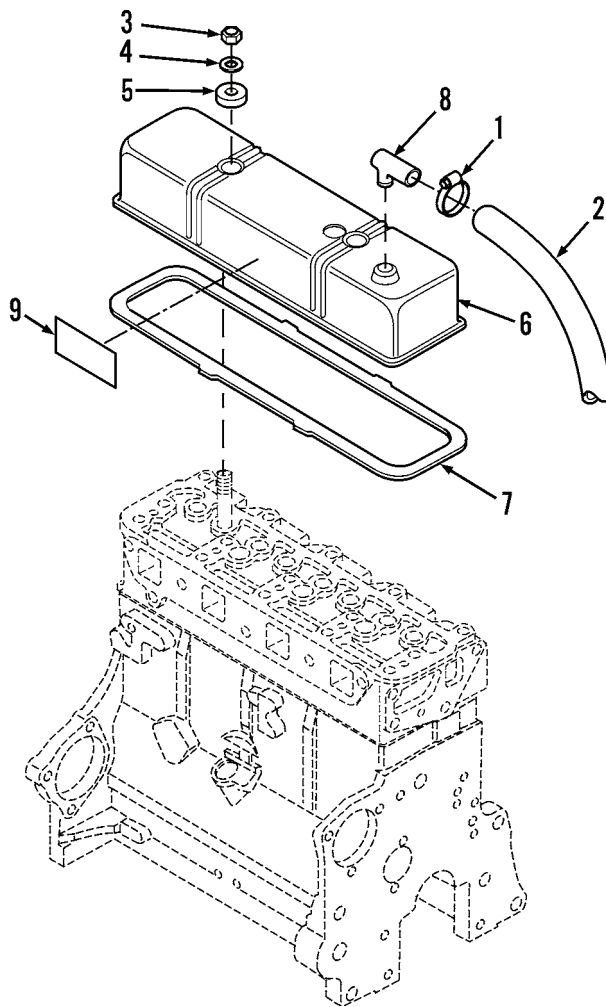

444-1233

**Figure 1. Rocker Arm Cover.****END OF TASK**

**CLEANING****WARNING**

- Solvent cleaning compound MIL-PRF-680 Type III is an environmentally compliant and low toxic material. However, it may be irritating to the eyes and skin. Use protective gloves and goggles. Use in well-ventilated areas. Keep away from open flames and other sources of ignition. Failure to do so may result in injury or death to personnel.
  - Particles blown by compressed air are hazardous. DO NOT exceed 15 PSI (103 kPa) nozzle pressure when drying parts with compressed air. DO NOT direct compressed air against human skin. Make sure air stream is directed away from user and other personnel in the area. To prevent injury, user must wear protective goggles or face shield. Failure to follow this warning may result in injury to personnel.
1. Clean rocker arm cover and top of engine cylinder head by scraping away all remaining gasket material from mating surfaces.
  2. Clean rocker arm cover, clamp, nuts, washers, and breather elbow with solvent cleaning compound. Dry with compressed air.

**END OF TASK****INSPECTION**

1. Inspect rocker arm cover. Replace if cracked or damaged so as to cause leakage.
2. Inspect all other parts. Replace if cracked, worn, or threads are damaged.

**END OF TASK****REPAIR**

Use a hammer and wooden backing block to remove any small dents from rocker arm cover. Ensure gasket mating surface on rocker arm cover is not deformed.

**END OF TASK****INSTALLATION**

1. Install breather elbow (Figure 1, Item 8) and new decal (Figure 1, Item 9), if removed, on rocker arm cover (Figure 1, Item 6).
2. Position new gasket (Figure 1, Item 7) and rocker arm cover (Figure 1, Item 6) on engine cylinder head.
3. Install two grommets (Figure 1, Item 5), washers (Figure 1, Item 4) and nuts (Figure 1, Item 3) on rocker arm cover (Figure 1, Item 6). Tighten nuts to 4 to 6 lb-ft (5 to 8 Nm).
4. Install hose clamp (Figure 1, Item 1) on breather hose (Figure 1, Item 2).
5. Connect breather hose (Figure 1, Item 2) to breather elbow (Figure 1, Item 8). Tighten hose clamp (Figure 1, Item 1).

**END OF TASK****END OF WORK PACKAGE**



# DIRECT SUPPORT MAINTENANCE INSTRUCTIONS

## ROCKER ARM COVER REPLACEMENT (MODEL 4-390)

Removal, Cleaning, Inspection, Installation

### INITIAL SETUP

#### MAINTENANCE LEVEL

Direct Support

#### Tools and Special Tools

Tool kit, general mechanic's (Item 15, WP 0309)

#### Materials/Parts

Cleaning compound, solvent (Item 10, WP 0310)

#### Materials/Parts - Continued

Rag, wiping (Item 26, WP 0310)

Gasket (4)

#### Equipment Condition

Vehicle parked on level surface

Engine OFF

Parking brake applied

Top hood removed (WP 0181)

### REMOVAL

#### NOTE

Perform steps 1 and 2 for each of four rocker arm covers.

1. At top of engine, remove screw assembly (Figure 1, Item 1) and rocker arm cover (Figure 1, Item 2) from engine cylinder head.
2. Remove gasket (Figure 1, Item 3). Discard gasket.

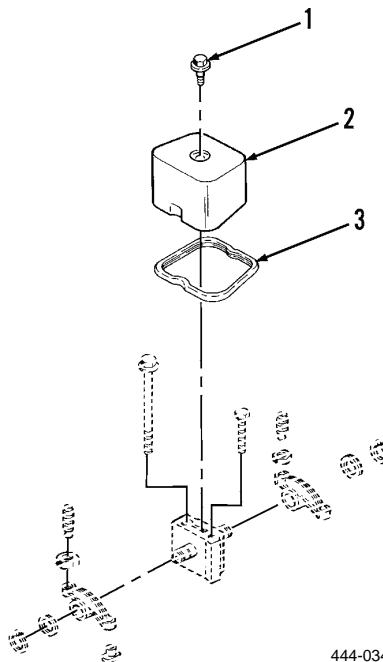

444-0347

Figure 1. Rocker Arm Cover.

### END OF TASK

**CLEANING****WARNING**

- Solvent cleaning compound MIL-PRF-680 Type III is an environmentally compliant and low toxic material. However, it may be irritating to the eyes and skin. Use protective gloves and goggles. Use in well-ventilated areas. Keep away from open flames and other sources of ignition. Failure to do so may result in injury or death to personnel.
  - Particles blown by compressed air are hazardous. DO NOT exceed 15 PSI (103 kPa) nozzle pressure when drying parts with compressed air. DO NOT direct compressed air against human skin. Make sure air stream is directed away from user and other personnel in the area. To prevent injury, user must wear protective goggles or face shield. Failure to follow this warning may result in injury to personnel.
1. Clean screw assemblies with solvent cleaning compound. Dry thoroughly with compressed air.
  2. Clean rocker arm covers and cylinder head by scraping all gasket residue from mating surfaces.
  3. Clean rocker arm covers with solvent cleaning compound. Dry thoroughly with compressed air.

**END OF TASK****INSPECTION**

1. Inspect rocker arm covers. Replace if dented, cracked, or damaged so as to cause oil leakage.
2. Inspect screw assemblies. Replace if cracked, worn, or threads are damaged.

**END OF TASK**



**INSTALLATION****NOTE**

Perform steps 1 and 2 for each of four rocker arm covers.

1. At top of engine, position new gasket (Figure 2, Item 3) on top of engine cylinder head.
2. Install rocker arm cover (Figure 2, Item 2) with screw assembly (Figure 2, Item 1). Tighten screw assembly to 18 lb-ft (24 Nm).

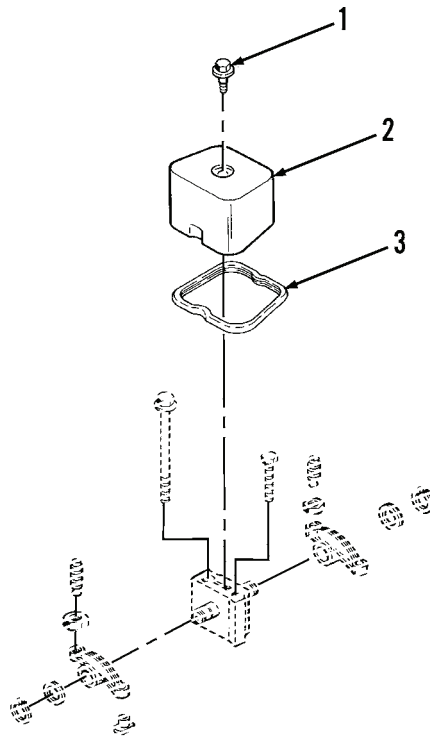

444-0347

**Figure 2. Rocker Arm Cover.**

**END OF TASK****END OF WORK PACKAGE**



---

## DIRECT SUPPORT MAINTENANCE INSTRUCTIONS

### ROCKER ARM ASSEMBLY MAINTENANCE (MODEL 207)

Removal, Disassembly, Cleaning, Inspection, Assembly/Installation, Adjustment

---

#### INITIAL SETUP

##### Maintenance Level

Direct Support

##### Tools and Special Tools

Tool kit, general mechanic's (Item 15, WP 0309)

Shop equipment, common no. 1 (Item 2, WP 0309)

Bore gage, 0 to 1 in.

Micrometer, 0 to 1 in.

Spring tester

##### Materials/Parts

Cleaning compound, solvent (Item 10, WP 0310)

##### Materials/Parts - Continued

Lubricating oil, OE/HDO-15/40 (Item 21, WP 0310)

Rag, wiping (Item 26, WP 0310)

##### References

WP 0206

##### Equipment Condition

Vehicle parked on level surface

Engine OFF

Parking brake applied

Rocker arm cover removed (WP 0222)

---

**REMOVAL**

1. At top of engine cylinder head, remove drilled bolt (Figure 1, Item 1), capscrew (Figure 1, Item 3), and two washers (Figure 1, Item 2).
2. While supporting right-hand rocker arms (Figure 1, Item 6) and left-hand rocker arms (Figure 1, Item 7), remove rear bracket (Figure 1, Item 4) and front bracket (Figure 1, Item 5).
3. Remove three capscrews (Figure 1, Item 9) and washers (Figure 1, Item 2).
4. Remove rocker arms (Figure 1, Items 6 and 7) and two springs (Figure 1, Item 8). Pull from front and rear end of shafts (Figure 1, Item 12).
5. Grasp ends of shafts (Figure 1, Item 12), push together, and remove rocker arm assembly from cylinder head.
6. Remove eight push rods (Figure 1, Item 13) from cylinder head.

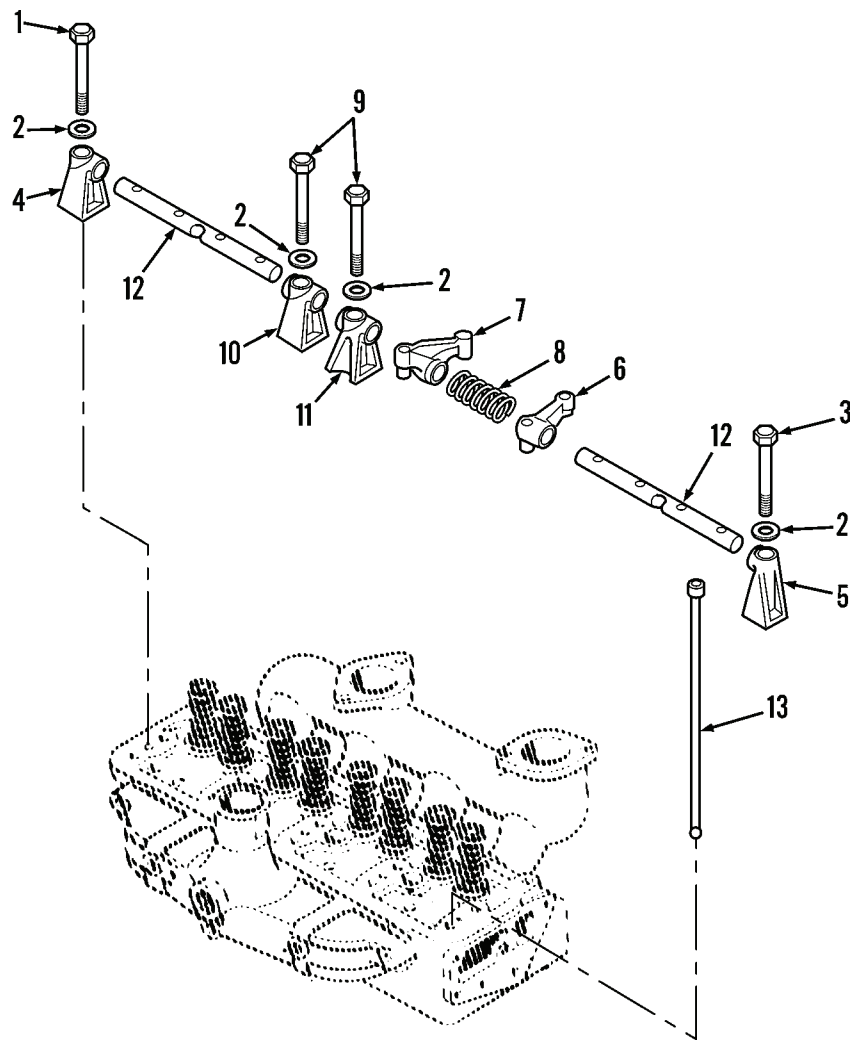

444-1234

Figure 1. Rocker Arm Assembly.

**END OF TASK**

**DISASSEMBLY**

1. Pull two shafts (Figure 1, Item 12) of rocker arm assembly from center bracket (Figure 1, Item 10).
2. Pull rocker arms (Figure 1, Items 6 and 7) and springs (Figure 1, Item 8) from shafts (Figure 1, Item 12).
3. Pull intermediate brackets (Figure 1, Item 11) from shafts (Figure 1, Item 12).

**END OF TASK****CLEANING****CAUTION**

Be careful not to scratch push rods or shafts in step 1.

1. Clean shafts (Figure 1, Item 12) and push rods (Figure 1, Item 13) by removing carbon and varnish deposits with a fine, power-driven wire brush.

**WARNING**

- Solvent cleaning compound MIL-PRF-680 Type III is an environmentally compliant and low toxic material. However, it may be irritating to the eyes and skin. Use protective gloves and goggles. Use in well-ventilated areas. Keep away from open flames and other sources of ignition. Failure to do so may result in injury or death to personnel.
  - Particles blown by compressed air are hazardous. DO NOT exceed 15 PSI (103 kPa) nozzle pressure when drying parts with compressed air. DO NOT direct compressed air against human skin. Make sure air stream is directed away from user and other personnel in the area. To prevent injury, user must wear protective goggles or face shield. Failure to follow this warning may result in injury to personnel.
2. Clean all parts with solvent cleaning compound. Dry thoroughly with compressed air.
  3. Flush rocker arm shafts and drilled bolt to remove internal particles. Use compressed air to ensure oil holes are free of obstructions.

**END OF TASK****INSPECTION**

1. Inspect drilled bolt, washers, and capscrews. Replace if worn or threads are damaged.
2. Inspect rocker arm shafts. Measure outside diameter with micrometer at worn spots on bottom of shaft. Replace shaft if outer diameter is less than 0.622 in. (15.80 mm), or if shaft is corroded, pitted, cracked, or scored.
3. Inspect springs. Install in spring tester. Ensure force to compress spring to 1.75 in. (44 mm) is 7.5 to 8.5 lb (3.4 to 3.8 kg). Replace spring if required force is not 7.5 to 8.5 lb (3.4 to 3.8 kg).
4. Inspect rocker arms and brackets. Use bore gage and check inside diameter. Measure bore gage with micrometer. Replace if inside diameter is greater than 0.626 in. (15.90 mm), if pitted, scored, or cracked, or if rocker arm adjusting screw threads damaged.
5. Inspect eight push rods. Replace if bent (place rod on flat surface and roll over surface; rod should roll smoothly indicating it is not bent), cracked, pitted, or excessively worn.

**END OF TASK**

**ASSEMBLY/INSTALLATION**

1. Apply thin coat of lubricating oil to all parts.
2. Position eight push rods (Figure 2, Item 13) in bores of cylinder head.
3. Position center bracket (Figure 2, Item 10) on cylinder head.
4. Install washer (Figure 2, Item 2) and capscrew (Figure 2, Item 9) on center bracket (Figure 2, Item 10). Hand-tighten capscrew.

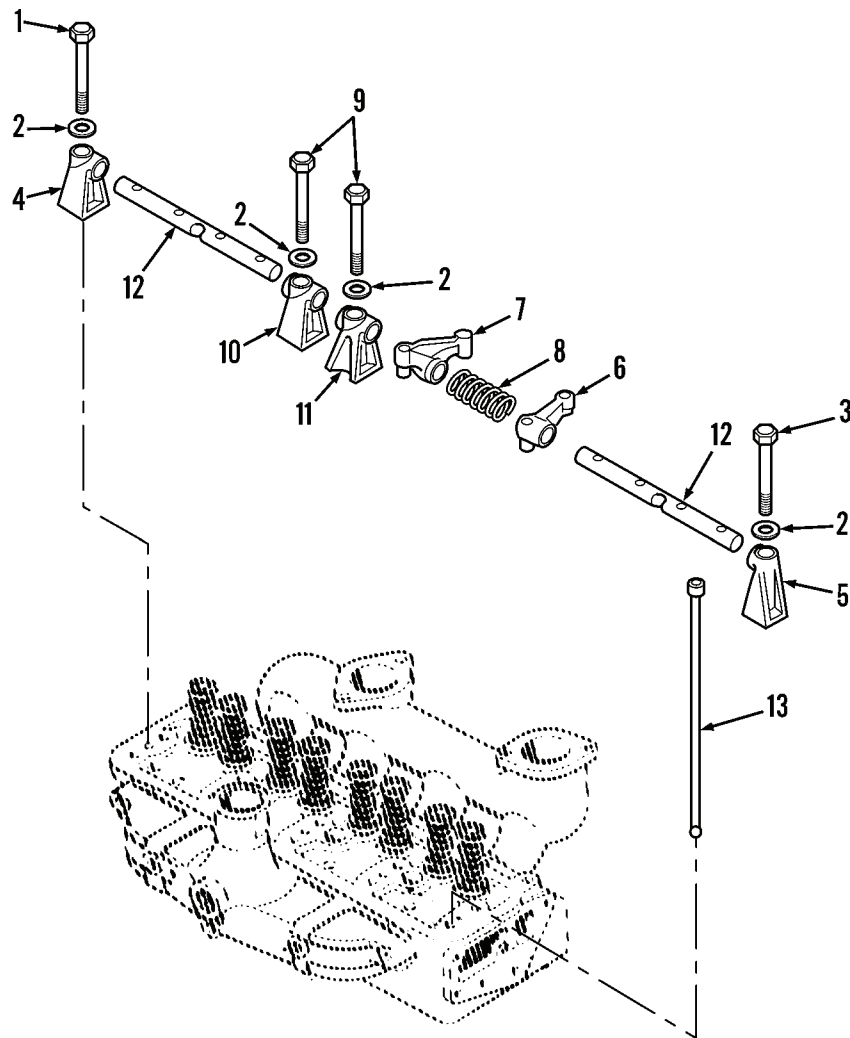

444-1234

**Figure 2. Rocker Arm Assembly.**

**ASSEMBLY/INSTALLATION - CONTINUED**

**NOTE**

Intermediate brackets are installed on cylinder head with slanted side toward push rods.

5. Install intermediate brackets (Figure 3, Item 11) on shafts (Figure 3, Item 12). Front shaft is installed with short end of shaft (as measured from shaft cut-out) toward fan end of engine. Rear shaft is installed with short end of shaft toward starter end of engine.

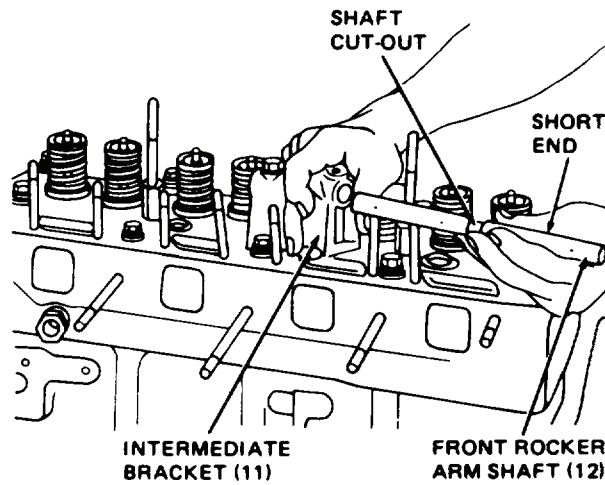

TA127110

**Figure 3. Intermediate Brackets.**

6. Install spring (Figure 4, Item 8) and rocker arms (Figure 4, Items 6 and 7). Push on long end of shafts (Figure 2, Item 12). Be sure slant of rocker arms is correct as shown (Figure 4).

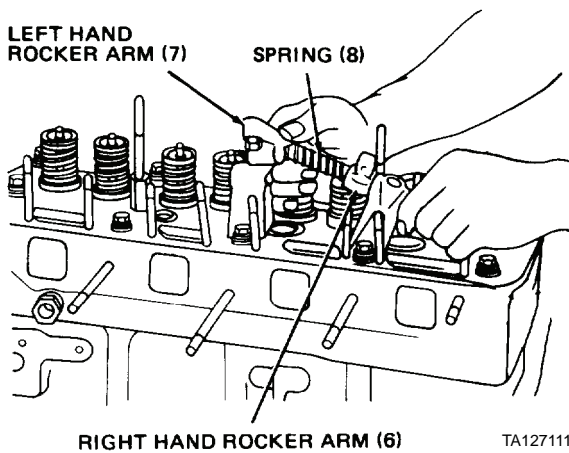

TA127111

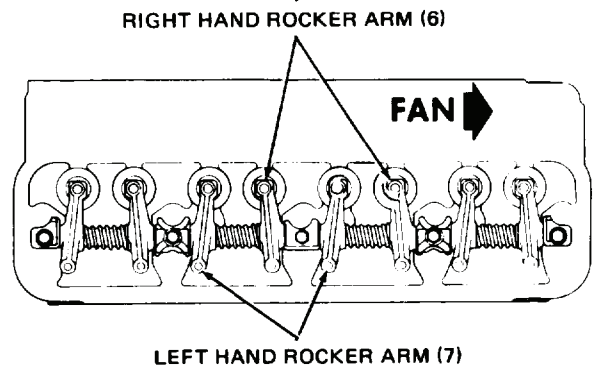

TA127112

**Figure 4. Springs and Rocker Arms.**

**ASSEMBLY/INSTALLATION - CONTINUED**

7. Install rocker arm shafts. Insert long end of shafts into center bracket (Figure 7, Item 10). Then position intermediate brackets (Figure 5, Item 11) on cylinder head.
8. Install two washers (Figure 7, Item 2) and capscrews (Figure 7, Item 9). Hand-tighten only, to secure intermediate brackets (Figure 7, Item 11).

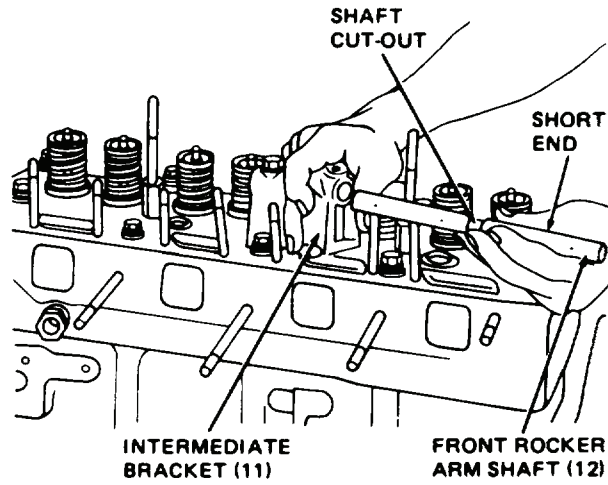

TA127110

**Figure 5. Rocker Arm Shafts.**

**NOTE**

Ensure oil holes in shafts are positioned horizontally as shown in step 9.

9. Install spring (Figure 6, Item 8) and rocker arms (Figure 6, Items 6 and 7). Push on short end of shafts (Figure 5, Item 12). Be sure slant of rocker arms is correct as shown.

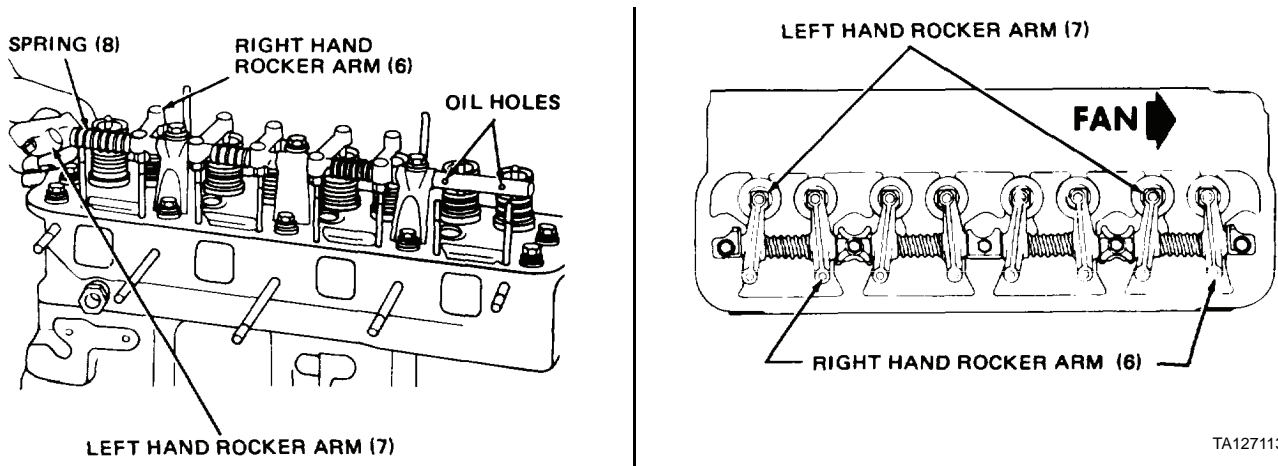

TA127114

TA127113

**Figure 6. Springs and Remaining Rocker Arms.**



**ASSEMBLY/INSTALLATION - CONTINUED**

10. Position rear bracket (Figure 7, Item 4) and front bracket (Figure 7, Item 5). Push shaft (Figure 7, Item 12) against tension of spring (Figure 7, Item 8).
11. Install washer (Figure 7, Item 2) and capscrew (Figure 7, Item 3). Hand-tighten only, to secure front bracket (Figure 7, Item 5).
12. Install drilled bolt (Figure 7, Item 1) and washer (Figure 7, Item 2). Hand-tighten only, to secure rear bracket (Figure 7, Item 4).
13. Tighten rocker arm bracket bolts and capscrews (Figure 7, Items 1, 3, and 9) to 25 to 30 lb-ft (34 to 41 Nm).

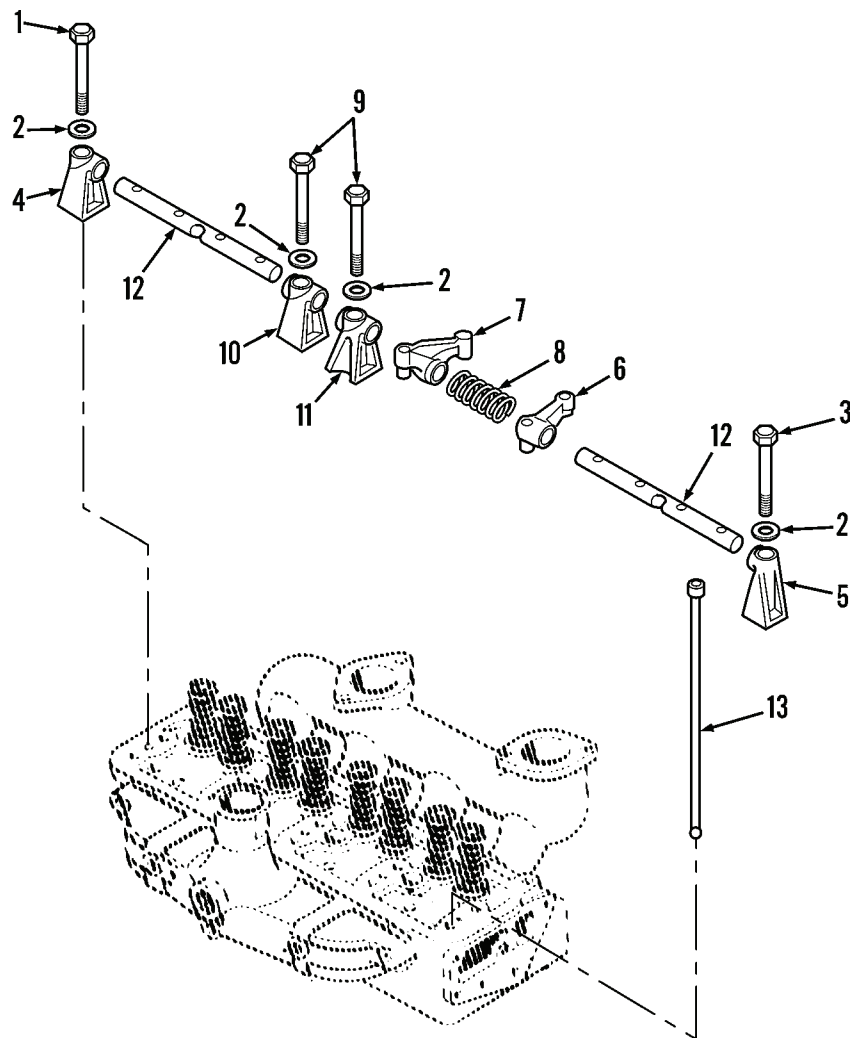

444-1234

**Figure 7. Rocker Arm Assembly.****END OF TASK****ADJUSTMENT**

Adjust valve tappet clearance (WP 0206).

**END OF TASK****END OF WORK PACKAGE**



---

## DIRECT SUPPORT MAINTENANCE INSTRUCTIONS

### ROCKER ARM ASSEMBLY MAINTENANCE (MODEL 4-390)

Removal, Disassembly, Cleaning, Inspection, Assembly, Adjustment

---

#### INITIAL SETUP

##### Maintenance Level

Direct Support

##### Tools and Special Tools

Tool kit, general mechanic's (Item 15, WP 0309)

Shop equipment, common no. 1 (Item 2, WP 0309)

Bore gage, 0 to 1 in.

Micrometer, 0 to 1 in.

##### Materials/Parts

Cleaning compound, solvent (Item 10, WP 0310)

##### Materials/Parts - Continued

Lubricating oil, OE/HDO-15/40 (Item 21, WP 0310)

Rag, wiping (Item 26, WP 0310)

##### References

WP 0207

##### Equipment Condition

Vehicle parked on level surface

Engine OFF

Parking brake applied

Rocker arm cover removed (WP 0223)

---

**REMOVAL****NOTE**

Perform steps 1 and 2 and *Disassembly* in this work package to remove each of four rocker arm assemblies.

1. At top of engine cylinder head, remove smaller capscrew (Figure 1, Item 2) first. Then, remove larger capscrew (Figure 1, Item 1).
2. Remove rocker arm support (Figure 1, Item 3) as an assembly.
3. Remove two push rods (Figure 1, Item 4) from cylinder head.

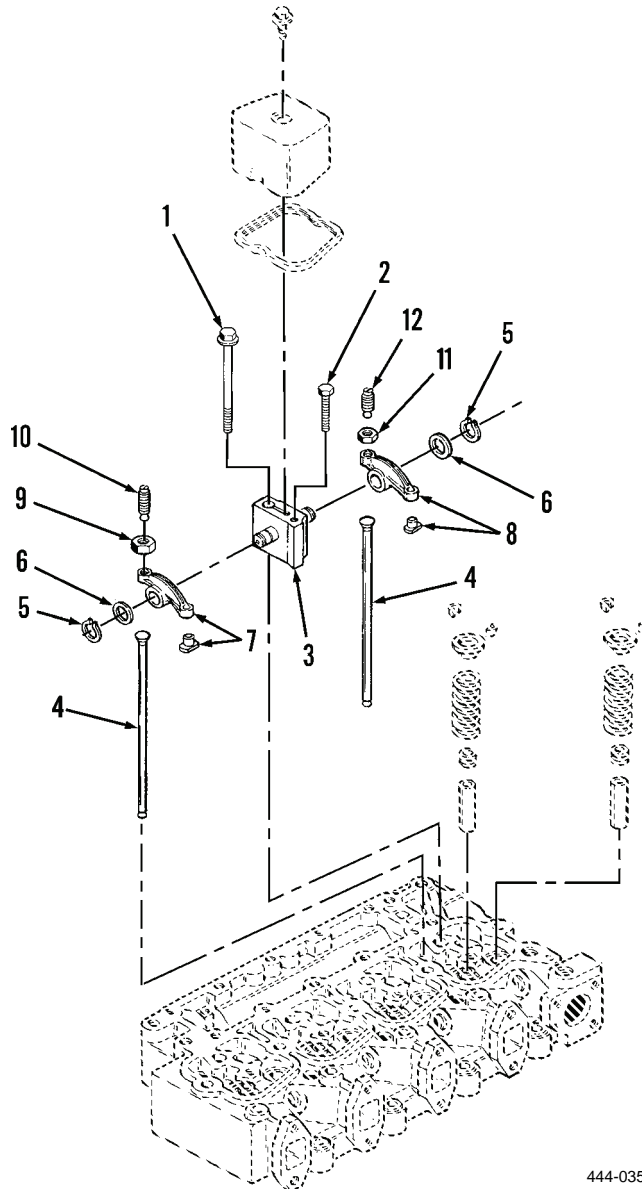

444-0354

**Figure 1. Rocker Arm Assembly.****END OF TASK**

**DISASSEMBLY**

1. Remove two snap rings (Figure 1, Item 5) and washers (Figure 1, Item 6) from rocker arm support (Figure 1, Item 3).
2. Remove rocker arm assemblies (Figure 1, Items 7 and 8) from rocker arm support (Figure 1, Item 3).
3. Remove nut (Figure 1, Item 9) and adjusting screw (Figure 1, Item 10) from rocker arm (Figure 1, Item 7).
4. Remove nut (Figure 1, Item 11) and adjusting screw (Figure 1, Item 12) from rocker arm (Figure 1, Item 8).

**END OF TASK****CLEANING****CAUTION**

Be careful not to scratch push rods or shafts in step 1.

1. Clean push rods (Figure 1, Item 4) by removing carbon and varnish deposits with a fine, power-driven wire brush.

**WARNING**

- Solvent cleaning compound MIL-PRF-680 Type III is an environmentally compliant and low toxic material. However, it may be irritating to the eyes and skin. Use protective gloves and goggles. Use in well-ventilated areas. Keep away from open flames and other sources of ignition. Failure to do so may result in injury or death to personnel.
- Particles blown by compressed air are hazardous. DO NOT exceed 15 PSI (103 kPa) nozzle pressure when drying parts with compressed air. DO NOT exceed 30 psi (207 kPa) nozzle pressure when drying parts with compressed air. DO NOT direct compressed air against human skin. Make sure air stream is directed away from user and other personnel in the area. To prevent injury, user must wear protective goggles or face shield. Failure to follow this warning may result in injury to personnel.

**NOTE**

Flush rocker arm supports to remove residual material. Use compressed air to free oil holes from any obstruction.

2. Clean all other parts with solvent cleaning compound. Dry thoroughly with compressed air.

**END OF TASK**

**INSPECTION**

1. Inspect shafts of rocker arm supports by measuring for out-of-round (Figure 2). Measure in three locations on shaft. If measurement is less than 0.7456 in. (18.938 mm), replace rocker arm support.

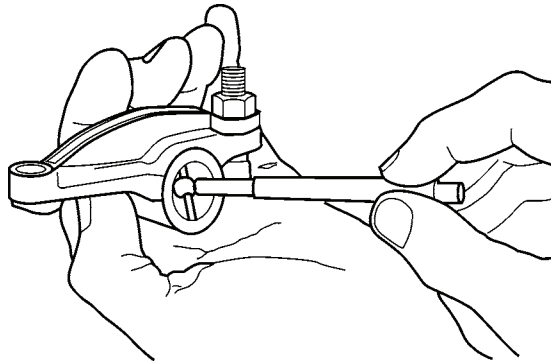

444-0352

**Figure 2. Measuring Bore of Rocker Arm.**

2. Inspect rocker arm assemblies by measuring bore with a bore gage (Figure 3). Measure in three locations inside bore.

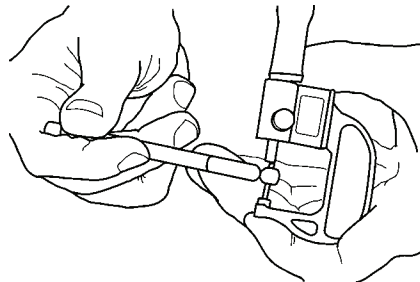

444-0353

**Figure 3. Measuring Bore Gage.**

3. If measurement is more than 0.750 in. (19.05 mm), replace rocker arm assembly (Figure 2, Items 7 or 8).

**END OF TASK****ASSEMBLY****NOTE**

Perform steps 1 and 2 and *Installation* in this work package for each of four rocker arm supports.

1. Loosely install adjusting screws (Figure 4, Items 9 and 12) and nuts (Figure 4, Items 10 and 11) on rocker arms (Figure 4, Items 7 and 8).
2. Install rocker arms (Figure 4, Items 7 and 8) on rocker arm supports (Figure 4, Item 3) with washers (Figure 4, Item 6) and snap rings (Figure 4, Item 5).

**END OF TASK**

**INSTALLATION**

1. Install push rods (Figure 4, Item 4) into cylinder head.
2. Position rocker arm support (Figure 4, Item 3) assembly on top of cylinder head.
3. Apply thin coat of oil to threads of capscrews (Figure 4, Item 1).
4. Install capscrews (Figure 4, Items 1 and 2) on rocker arm supports (Figure 4, Item 3). Tighten capscrews finger-tight.
5. Tighten all capscrews (Figure 4, Item 1) to 30, 60, and 93 lb-ft (41, 81, and 126 Nm).
6. Tighten all capscrews (Figure 4, Item 2) to 18 lb-ft (24 Nm).

**END OF TASK****ADJUSTMENT**

To adjust rocker arms for proper valve tappet clearance, refer to WP 0207.

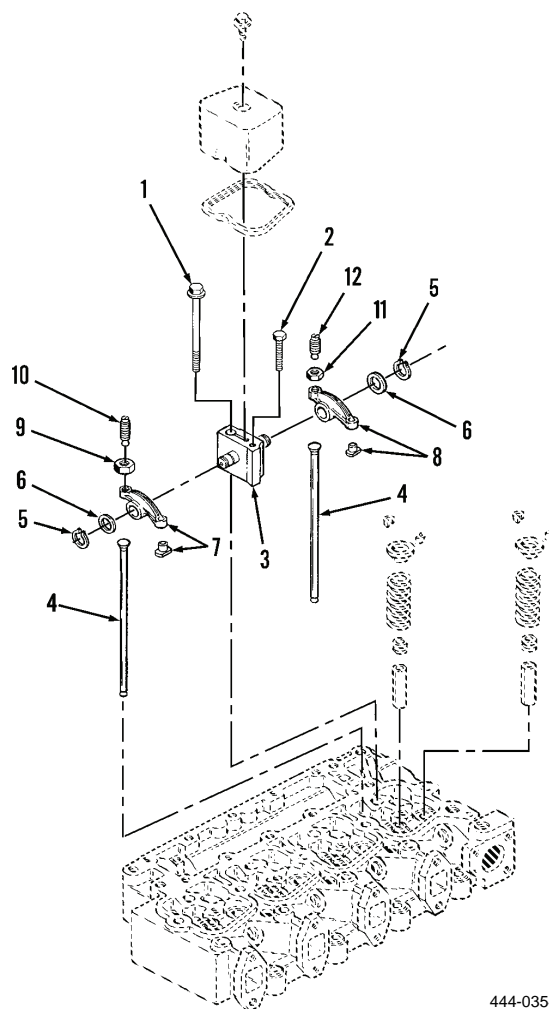

444-0354

**Figure 4. Rocker Arm Assembly.**

**END OF TASK****END OF WORK PACKAGE**





---

## DIRECT SUPPORT MAINTENANCE INSTRUCTIONS

### ENGINE OIL PAN MAINTENANCE (MODEL 207)

Removal, Cleaning, Inspection, Repair, Installation

---

#### INITIAL SETUP

**Maintenance Level**

Direct Support

**Tools and Special Tools**

Tool kit, general mechanic's (Item 15, WP 0309)

**Materials/Parts**

Cleaning compound, solvent (Item 10, WP 0310)

Permatex (Item 30, WP 0310)

Rag, wiping (Item 26, WP 0310)

**Materials/Parts - Continued**

Gasket

**Equipment Condition**

Vehicle parked on level surface

Engine OFF

Parking brake applied

Power pack removed (WP 0211)

Engine oil drained (WP 0049)

---

**REMOVAL**

1. At bottom of engine, remove four long bolts (Figure 1, Item 1) and reinforcement strip (Figure 1, Item 2) from oil pan (Figure 1, Item 4).
2. While supporting oil pan (Figure 1, Item 4), remove 14 short bolts (Figure 1, Item 3), oil pan, and gasket (Figure 1, Item 5) from engine. Discard gasket.
3. Remove drain plug (Figure 1, Item 6) and gasket (Figure 1, Item 7) from oil pan (Figure 1, Item 4).

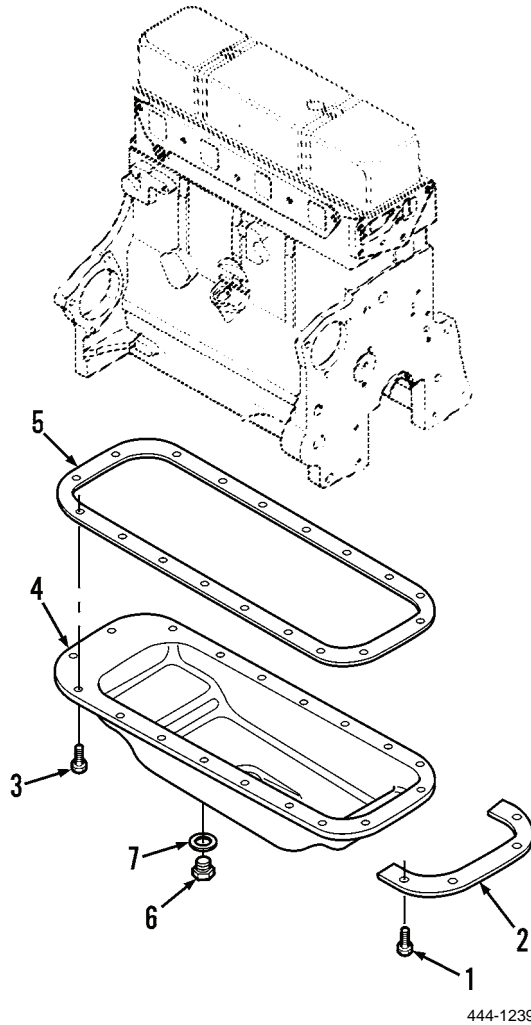
**Figure 1. Engine Oil Pan.****END OF TASK**

**CLEANING****WARNING**

- Solvent cleaning compound MIL-PRF-680 Type III is an environmentally compliant and low toxic material. However, it may be irritating to the eyes and skin. Use protective gloves and goggles. Use in well-ventilated areas. Keep away from open flames and other sources of ignition. Failure to do so may result in injury or death to personnel.
  - Particles blown by compressed air are hazardous. DO NOT exceed 15 PSI (103 kPa) nozzle pressure when drying parts with compressed air. DO NOT direct compressed air against human skin. Make sure air stream is directed away from user and other personnel in the area. To prevent injury, user must wear protective goggles or face shield. Failure to follow this warning may result in injury to personnel.
1. Clean mating surfaces of engine crankcase and oil pan by scraping away any remaining gasket material.
  2. Clean all parts with solvent cleaning compound. Dry thoroughly with compressed air.

**END OF TASK****INSPECTION**

1. Inspect oil pan. Replace if cracked or damaged. If dented, perform *Repair* in this work package.
2. Inspect reinforcement strip. Replace if cracked or damaged.
3. Inspect bolts and drain plug. Replace if worn or threads are damaged.

**END OF TASK****REPAIR**

Repair small dents in oil pan by pounding with a hammer and wooden backing block. Ensure gasket flanged surface of oil pan is not deformed.

**END OF TASK****INSTALLATION**

1. Apply Permatex 2 on top and bottom surfaces of gasket (Figure 1, Item 5) at front and rear portions only. Position gasket on mating surface of oil pan (Figure 1, Item 4).
2. Position oil pan (Figure 1, Item 4) on engine with bolt holes of oil pan in alignment with bolt holes of engine.
3. While supporting oil pan (Figure 1, Item 4), install 14 short bolts (Figure 1, Item 3). Tighten bolts alternately to 10 to 12 lb-ft (14 to 16 Nm).
4. Install reinforcing strip (Figure 1, Item 2) on oil pan (Figure 1, Item 4) with four long bolts (Figure 1, Item 1). Tighten bolts to 15 to 20 lb-ft (20 to 27 Nm).
5. Install gasket (Figure 1, Item 7) and drain plug (Figure 1, Item 6) on oil pan (Figure 1, Item 4). Tighten drain plug to 29 to 31 lb-ft (39 to 42 Nm).
6. Install power pack (WP 0211).
7. Fill engine crankcase with oil (WP 0049).

**END OF TASK****END OF WORK PACKAGE**



---

## DIRECT SUPPORT MAINTENANCE INSTRUCTIONS

### ENGINE OIL PAN MAINTENANCE (MODEL 4-390)

Removal, Cleaning, Inspection, Repair, Installation

---

#### INITIAL SETUP

**Maintenance Level**

Direct Support

**Tools and Special Tools**

Tool kit, general mechanic's (Item 15, WP 0309)

Container

**Materials/Parts**

Cleaning compound, solvent (Item 10, WP 0310)

Permatex (Item 30, WP 0310)

Rag, wiping (Item 26, WP 0310)

**Materials/Parts - Continued**

Gasket (2)

**References**

WP 0050

**Equipment Condition**

Vehicle parked on level surface

Engine OFF

Parking brake applied

Engine removed from vehicle (WP 0212)

---

**REMOVAL****NOTE**

Consult your unit/local hazardous waste disposal center or safety office for local regulatory guidance for disposal of oil. If further information is needed, please contact the Army Environmental Hotline at 1-800-872-3845.

1. At bottom of engine, remove drain plug (Figure 1, Item 1) and O-ring (Figure 1, Item 2) and allow engine oil to drain into container.
2. While supporting oil pan (Figure 1, Item 5), remove 28 bolts (Figure 1, Item 3) and washers (Figure 1, Item 4).
3. Remove oil pan (Figure 1, Item 5) and gasket (Figure 1, Item 6) from engine. Discard gasket.

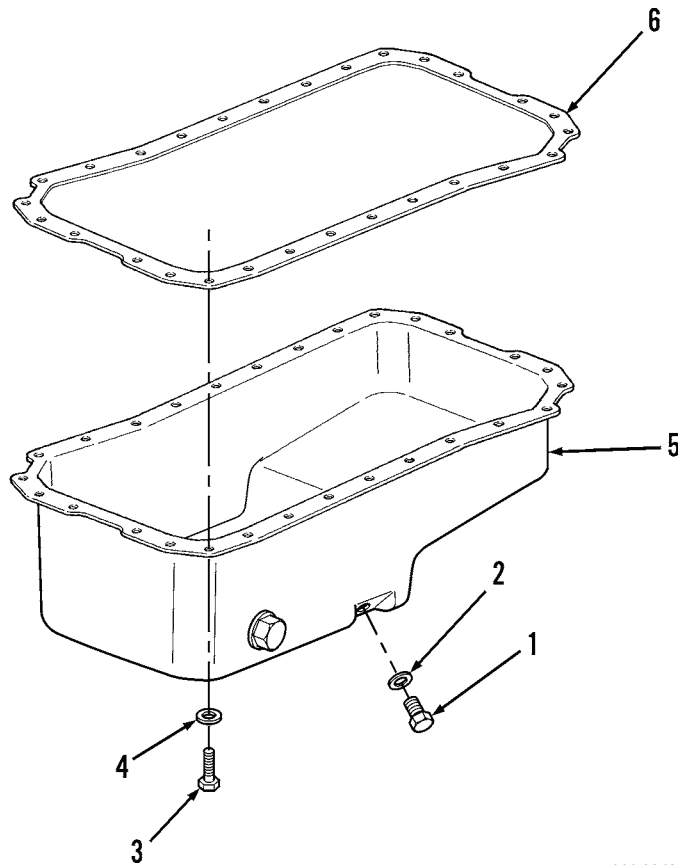

444-0348

**Figure 1. Engine Oil Pan.**

**REMOVAL - CONTINUED**

- Remove three bolts (Figure 2, Item 8), oil pick-up tube (Figure 2, Item 7), and gasket from bottom of engine. Discard gasket.

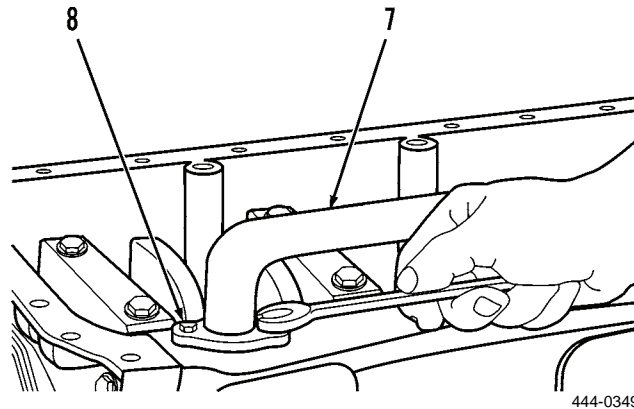

Figure 2. Oil Pick-Up Tube.

**END OF TASK****CLEANING**

**WARNING**



- Solvent cleaning compound MIL-PRF-680 Type III is an environmentally compliant and low toxic material. However, it may be irritating to the eyes and skin. Use protective gloves and goggles. Use in well-ventilated areas. Keep away from open flames and other sources of ignition. Failure to do so may result in injury or death to personnel.
  - Particles blown by compressed air are hazardous. **DO NOT** exceed 15 PSI (103 kPa) nozzle pressure when drying parts with compressed air. **DO NOT** direct compressed air against human skin. Make sure air stream is directed away from user and other personnel in the area. To prevent injury, user must wear protective goggles or face shield. Failure to follow this warning may result in injury to personnel.
- Clean oil pan flange and engine crankcase flange by scraping all gasket residue from mating surfaces.
  - Clean all parts with solvent cleaning compound. Dry thoroughly with compressed air.

**END OF TASK****INSPECTION**

- Inspect all bolts (Figure 1, Item 3) and drain plug (Figure 1, Item 1). Replace if worn, or if threads are damaged.
- Inspect O-ring (Figure 1, Item 2). Replace if worn, cracked, or deteriorated.
- Inspect oil pan (Figure 1, Item 5). Repair if dented (perform *Repair* in this work package). Replace if cracked.
- Inspect oil pick-up tube (Figure 2, Item 7). Replace if damaged.

**END OF TASK**

**REPAIR**

Repair oil pan by pounding out small dents with a hammer and wooden backing block. Ensure gasket mating surface of oil pan is not deformed.

**END OF TASK****INSTALLATION**

1. At bottom of engine, install new gasket, oil pick-up tube (Figure 3, Item 7), and three bolts (Figure 3, Item 8). Tighten bolts to 15 to 20 lb-ft (20 to 27 Nm).

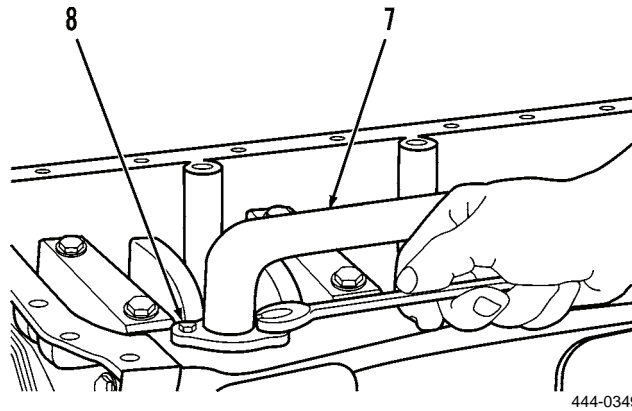
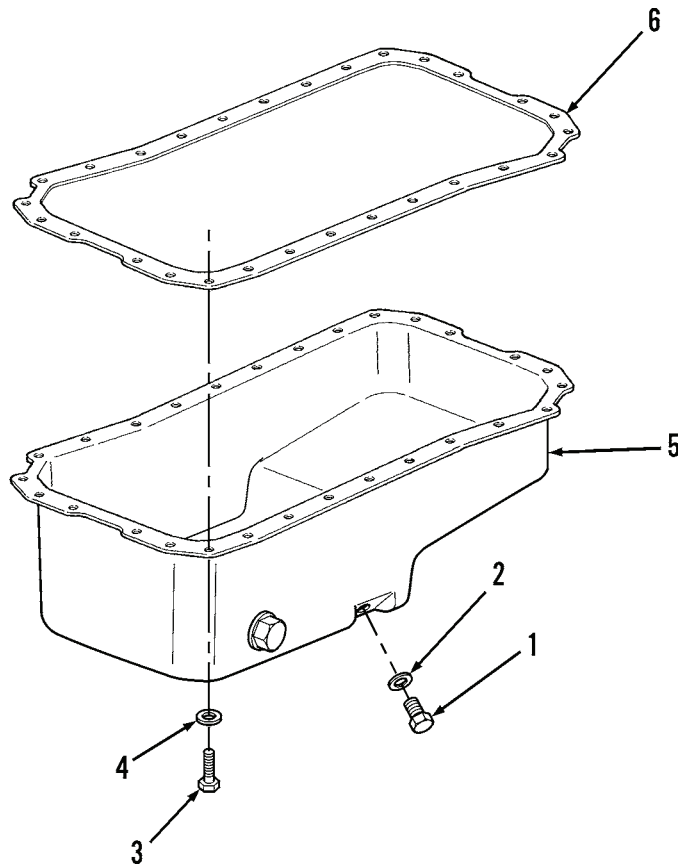

**Figure 3. Oil Pick-Up Tube.**



**INSTALLATION - CONTINUED**

2. Apply Permatex 2 on both sides of new gasket (Figure 4, Item 6) at front and rear portions only. Position gasket on mating surface of oil pan (Figure 4, Item 5).
3. Position oil pan (Figure 4, Item 5) on engine flange with gasket (Figure 4, Item 6) holes in alignment.
4. Install 28 washers (Figure 4, Item 4) and bolts (Figure 4, Item 3). Alternately tighten bolts to 15 to 20 lb-ft (20 to 27 Nm).
5. Install O-ring (Figure 4, Item 2) and drain plug (Figure 4, Item 1). Tighten drain plug to 50 to 60 lb-ft (68 to 81 Nm).

**Figure 4. Engine Oil Pan.**

6. Fill engine crankcase with lubricating oil (refer to WP 0050).

**END OF TASK****END OF WORK PACKAGE**



---

## DIRECT SUPPORT MAINTENANCE INSTRUCTIONS

### ENGINE OIL COOLER MAINTENANCE (MODEL 4-390)

Removal, Disassembly, Cleaning, Inspection, Assembly, Installation

---

#### INITIAL SETUP

##### Maintenance Level

Direct Support

##### Tools and Special Tools

Tool kit, general mechanic's (Item 15, WP 0309)

Shop equipment, common no. 1 (Item 2, WP 0309)

##### Materials/Parts

Cleaning compound, solvent (Item 10, WP 0310)

Rag, wiping (Item 26, WP 0310)

Gasket (2)

##### Materials/Parts - Continued

Seal (2)

##### Equipment Condition

Vehicle parked on level surface

Engine OFF

Parking brake applied

Right side panel removed (WP 0179)

Right hood panel removed (WP 0183)

Cooling system drained (WP 0079)

Oil filter removed (WP 0052)

Engine oil drained (WP 0050)

---

**REMOVAL**

1. At right side of engine, remove 14 capscrews (Figure 1, Item 1), filter head (Figure 1, Item 2), and gasket (Figure 1, Item 3) from oil cooler (Figure 1, Item 4). Discard gasket.
2. Remove oil cooler (Figure 1, Item 4) and gasket (Figure 1, Item 5) from side of engine. Discard gasket.

**END OF TASK****DISASSEMBLY**

1. At filter head (Figure 1, Item 2), remove cold oil relief valve (Figure 1, Item 6).
2. Remove plug (Figure 1, Item 7), seal (Figure 1, Item 8), spring (Figure 1, Item 9), and relief valve (Figure 1, Item 10) from filter head (Figure 1, Item 2). Discard seal.
3. Remove plug (Figure 1, Item 11).
4. Remove plug (Figure 1, Item 12), seal (Figure 1, Item 13), and fitting (Figure 1, Item 14). Discard seal.

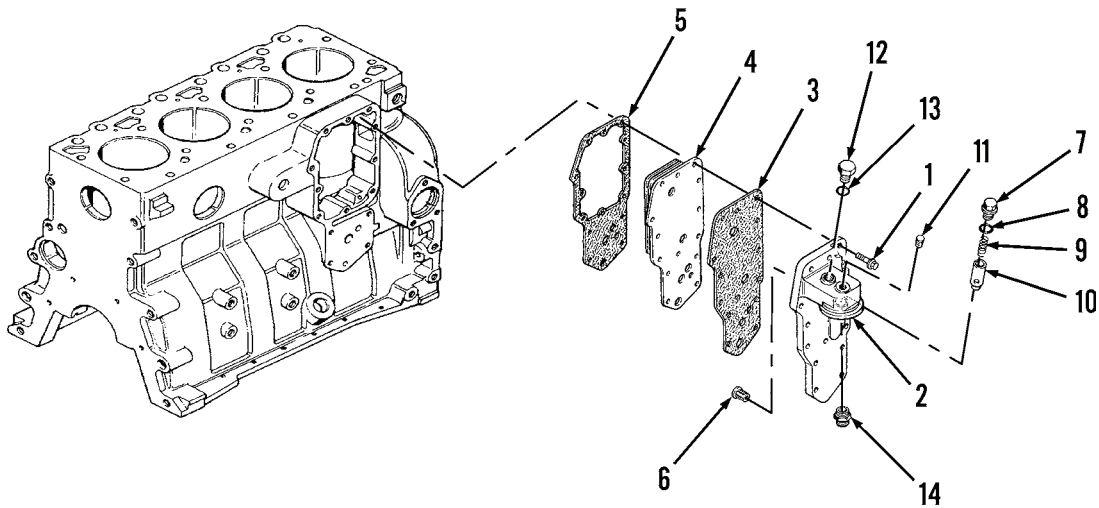

444-0168

**Figure 1. Engine Oil Cooler.****END OF TASK**

**CLEANING****WARNING**

Solvent cleaning compound MIL-PRF-680 Type III is an environmentally compliant and low toxic material. However, it may be irritating to the eyes and skin. Use protective gloves and goggles. Use in well-ventilated areas. Keep away from open flames and other sources of ignition. Failure to do so may result in injury or death to personnel.

Clean all parts with solvent cleaning compound. Dry thoroughly.

**END OF TASK****INSPECTION**

1. Inspect filter head (Figure 1, Item 2). Replace if cracked or damaged.
2. Inspect cold oil relief valve (Figure 1, Item 6) and relief valve (Figure 1, Item 10). Replace if cracked, worn, or scored.
3. Inspect all other parts. Replace if cracked, distorted, or threads are damaged.

**END OF TASK****ASSEMBLY**

1. At filter head (Figure 1, Item 2), install plug (Figure 1, Item 12), new seal (Figure 1, Item 13), and fitting (Figure 1, Item 14).
2. Install plug (Figure 1, Item 11).
3. Install relief valve (Figure 1, Item 10), spring (Figure 1, Item 9), new seal (Figure 1, Item 8), and plug (Figure 1, Item 7).
4. Install cold oil relief valve (Figure 1, Item 6).

**END OF TASK****INSTALLATION**

1. Position new gasket (Figure 1, Item 5) and oil cooler (Figure 1, Item 4) on right side of engine.
2. Install new gasket (Figure 1, Item 3) and filter head (Figure 1, Item 2) on oil cooler (Figure 1, Item 4) and engine with 14 capscrews (Figure 1, Item 1). Tighten capscrews to 18 lb-ft (24 Nm).

**END OF TASK****END OF WORK PACKAGE**



---

## DIRECT SUPPORT MAINTENANCE INSTRUCTIONS

### FUEL INJECTION LINES AND FITTINGS MAINTENANCE (MODEL 207)

Removal, Cleaning, Inspection, Installation, Leak Test

---

#### INITIAL SETUP

**Maintenance Level**

Direct Support

**Tools and Special Tools**

Tool kit, general mechanic's (Item 15, WP 0309)

**Materials/Parts**

Cleaning compound, solvent (Item 10, WP 0310)

Diesel fuel, arctic (Item 14, WP 0310)

Diesel fuel, DF-2 (Item 15, WP 0310)

**Materials/Parts - Continued**

Rag, wiping (Item 26, WP 0310)

Copper washer (8)

**Equipment Condition**

Vehicle parked on level surface

Engine OFF

Parking brake applied

Left and right side panels removed (WP 0179)

Fuel tank shut-off valve closed

Fuel return line disconnected from fuel injector tee fitting (WP 0063)

---

---

**REMOVAL****NOTE**

- Thoroughly steam clean area around fuel injectors, fuel filters, fuel injection pump, and fuel lines before starting removal.
  - Perform step 1 at each of four fuel injectors at top of engine.
1. At top of engine, loosen and remove tube nuts (Figure 1, Item 1), sleeves (Figure 1, Item 2), leak-off tubes (Figure 1, Item 3), cap nuts (Figure 1, Item 5), grommets (Figure 1, Item 6), and tees (Figure 1, Item 7).
  2. Loosen and remove tube nuts (Figure 1, Item 20), sleeves (Figure 1, Item 21), leak-off tube (Figure 1, Item 4), tee (Figure 1, Item 22), and sealing nut (Figure 1, Item 23) from fuel injection pump.
  3. Loosen and disconnect four tube nuts of injection tubes (Figure 1, Item 8) from fuel injectors.
  4. At fuel filters, loosen and disconnect two tube nuts (Figure 1, Item 9) from elbows (Figure 1, Item 10).
  5. Remove two elbows (Figure 1, Item 10) from fuel filter head.
  6. At fuel injection pump, loosen and disconnect tube nut (Figure 1, Item 11) from elbow (Figure 1, Item 12).
  7. Remove elbow (Figure 1, Item 12) and sealing nut (Figure 1, Item 14) from fuel injection pump.
  8. Remove fuel inlet line (Figure 1, Item 13) from between fuel injection pump and fuel filters.
  9. Remove screws (Figure 1, Item 17), tube clamps (Figure 1, Item 18), and nuts (Figure 1, Item 19) from four injection tubes (Figure 1, Item 8).
  10. At top of fuel injection pump, remove four connector bolts (Figure 1, Item 15), eight copper washers (Figure 1, Item 16), and four injection tubes (Figure 1, Item 8). Discard copper washers.



REMOVAL - CONTINUED

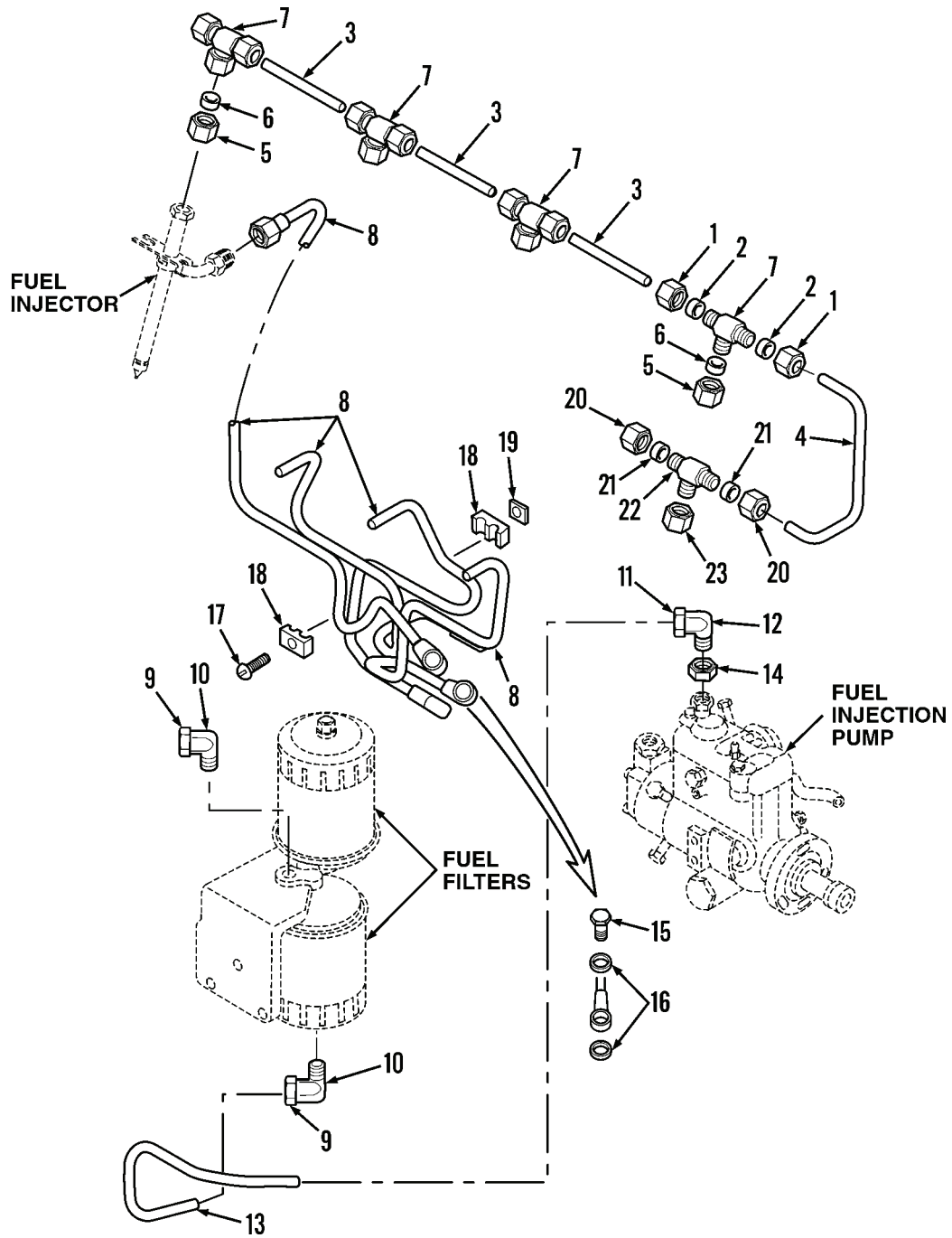

444-1240

Figure 1. Fuel Injection Lines and Fittings.

END OF TASK

**CLEANING****WARNING**

- Solvent cleaning compound MIL-PRF-680 Type III is an environmentally compliant and low toxic material. However, it may be irritating to the eyes and skin. Use protective gloves and goggles. Use in well-ventilated areas. Keep away from open flames and other sources of ignition. Failure to do so may result in injury or death to personnel.
  - DO NOT clean using fuel while smoking or near fire, flames, or sparks. Fuel may ignite, causing damage to machine and injury or death to personnel.
  - Particles blown by compressed air are hazardous. DO NOT exceed 15 PSI (103 kPa) nozzle pressure when drying parts with compressed air. DO NOT direct compressed air against human skin. Failure to follow this warning may result in injury to personnel. Make sure air stream is directed away from user and other personnel in the area. To prevent injury, user must wear protective goggles or face shield.
1. Clean all parts with solvent cleaning compound. Dry thoroughly.
  2. Clean tubes, lines, and fittings by flushing with clean diesel fuel to remove all traces of solvent cleaning compound. Dry thoroughly with compressed air.

**END OF TASK****INSPECTION**

1. Inspect tubes. Replace if dented or fittings are damaged.
2. Inspect all other parts. Replace if cracked or threads are damaged.

**END OF TASK****INSTALLATION**

1. At top of fuel injection pump, install four injection tubes (Figure 2, Item 8) with eight new copper washers (Figure 2, Item 16) and four connector bolts (Figure 2, Item 15). Do not fully tighten connector bolts.
2. At fuel injectors, connect four tube nuts of injection tubes (Figure 2, Item 8) to fuel injectors and tighten.
3. Tighten four connector bolts (Figure 2, Item 15) to 35 lb-ft (47 Nm).
4. Install tube clamps (Figure 2, Item 18) on four injection tubes (Figure 2, Item 8) with screws (Figure 2, Item 17) and nuts (Figure 2, Item 19).
5. Position fuel inlet line (Figure 2, Item 13) between fuel injection pump and fuel filters.
6. Install sealing nut (Figure 2, Item 14) and elbow (Figure 2, Item 12) on fuel injection pump. Tighten nut to 20 lb-ft (27 Nm).
7. Install tube nut (Figure 2, Item 11) on elbow (Figure 2, Item 12).
8. Install two elbows (Figure 2, Item 10) on fuel filter head.
9. Install two tube nuts (Figure 2, Item 9) on elbows (Figure 2, Item 10).
10. At fuel injection pump, install sealing nut (Figure 2, Item 23), tee (Figure 2, Item 22), leak-off tube (Figure 2, Item 4), sleeves (Figure 2, Item 21), and tube nuts (Figure 2, Item 20).

INSTALLATION - CONTINUED

NOTE

Perform step 11 at each of four fuel injectors at top of engine.

11. Install tees (Figure 2, Item 7), grommets (Figure 2, Item 6), cap nuts (Figure 2, Item 5), leak-off tubes (Figure 2, Item 3), sleeves (Figure 2, Item 2), and tube nuts (Figure 2, Item 1).

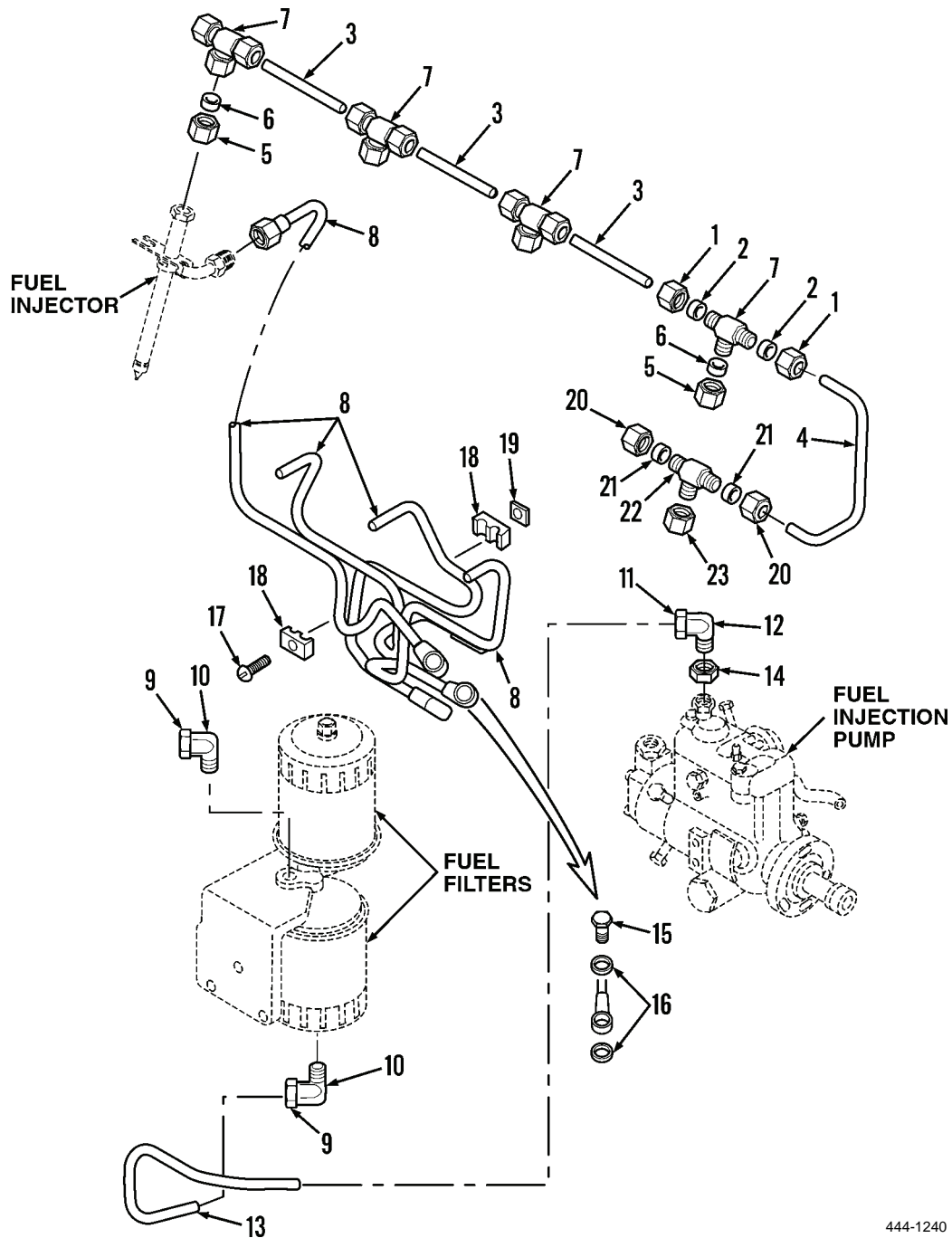

444-1240

Figure 2. Fuel Injection Lines and Fittings.

END OF TASK

**LEAK TEST**

1. Open fuel tank shut-off valve.
2. At ONE fuel injector, loosen tube nut of inlet tube.
3. Crank engine until fuel starts to flow from inlet tube. Stop cranking.
4. Tighten loosened tube nut of inlet tube.
5. Start engine and check for fuel leaks.

**END OF TASK****END OF WORK PACKAGE**

---

## DIRECT SUPPORT MAINTENANCE INSTRUCTIONS

### FUEL INJECTION LINES AND FITTINGS MAINTENANCE (MODEL 4-390)

Removal, Cleaning, Inspection, Installation/Replacement, Leak Test

---

#### INITIAL SETUP

**Maintenance Level**

Direct Support

**Tools and Special Tools**

Tool kit, general mechanic's (Item 15, WP 0309)

**Materials/Parts**

Cleaning compound, solvent (Item 10, WP 0310)

Diesel fuel, arctic (Item 14, WP 0310)

**Materials/Parts - Continued**

Diesel fuel, DF-2 (Item 15, WP 0310)

Rag, wiping (Item 26, WP 0310)

**Equipment Condition**

Vehicle parked on level surface

Engine OFF

Parking brake applied

Left and right side panels removed (WP 0179)

Top hood removed (WP 0181)

---

**REMOVAL****NOTE**

Thoroughly steam clean area around fuel injectors, fuel filters, fuel injection pump, and fuel lines before starting removal.

1. Remove four tube screws (Figure 1, Item 1) and seals (Figure 1, Item 2) from leak-off tube (Figure 1, Item 3).
2. Remove bolt (Figure 1, Item 4) from clamp (Figure 1, Item 5).
3. Remove screw (Figure 1, Item 6) and two washers (Figure 1, Item 7) from leak-off tube (Figure 1, Item 3).
4. Remove leak-off tube (Figure 1, Item 3) from bleed screw (Figure 1, Item 8).
5. Disconnect four inlet fittings from injection tubes (Figure 1, Item 9).
6. Remove five clamp bolts (Figure 1, Item 10) from cylinder head and disassemble five clamps (Figure 1, Item 11).
7. Disconnect four outlet fittings on injection tubes (Figure 1, Item 9) from fuel injection pump (Figure 1, Item 12).
8. Remove fuel injection tubes (Figure 1, Item 9) from engine.
9. Disconnect outlet fitting on fuel pump tube (Figure 1, Item 14) from fuel pump (Figure 1, Item 13).
10. Remove bleed screw (Figure 1, Item 8) and two washers (Figure 1, Item 15) from fuel filter.
11. Remove fuel pump tube (Figure 1, Item 14) from engine.
12. Remove bolt (Figure 1, Item 16), bleed screw (Figure 1, Item 17), and two washers (Figure 1, Item 18) from fuel pump inlet tube (Figure 1, Item 21).
13. Remove bleed screw (Figure 1, Item 19), two washers (Figure 1, Item 20), and fuel pump inlet tube (Figure 1, Item 21) from fuel injection pump (Figure 1, Item 12).

**NOTE**

Bolts are part of intake manifold.

14. Remove two bolts (Figure 1, Item 22) and mounts (Figure 1, Item 23) from intake manifold.

**END OF TASK****CLEANING****WARNING**

- DO NOT flush with diesel fuel while smoking or near fire, flames, or sparks. Fuel may ignite, causing damage to machine and injury or death to personnel.
  - Solvent cleaning compound MIL-PRF-680 Type III is an environmentally compliant and low toxic material. However, it may be irritating to the eyes and skin. Use protective gloves and goggles. Use in well-ventilated areas. Keep away from open flames and other sources of ignition. Failure to do so may result in injury or death to personnel.
  - Particles blown by compressed air are hazardous. DO NOT exceed 15 PSI (103 kPa) nozzle pressure when drying parts with compressed air. DO NOT direct compressed air against human skin. Make sure air stream is directed away from user and other personnel in the area. To prevent injury, user must wear protective goggles or face shield. Failure to follow this warning may result in injury to personnel.
1. Use solvent cleaning compound to clean all parts.

**CLEANING - CONTINUED**

- Flush all tubes, lines, and fittings with clean diesel fuel to remove all traces of solvent cleaning compound. Dry thoroughly with compressed air.

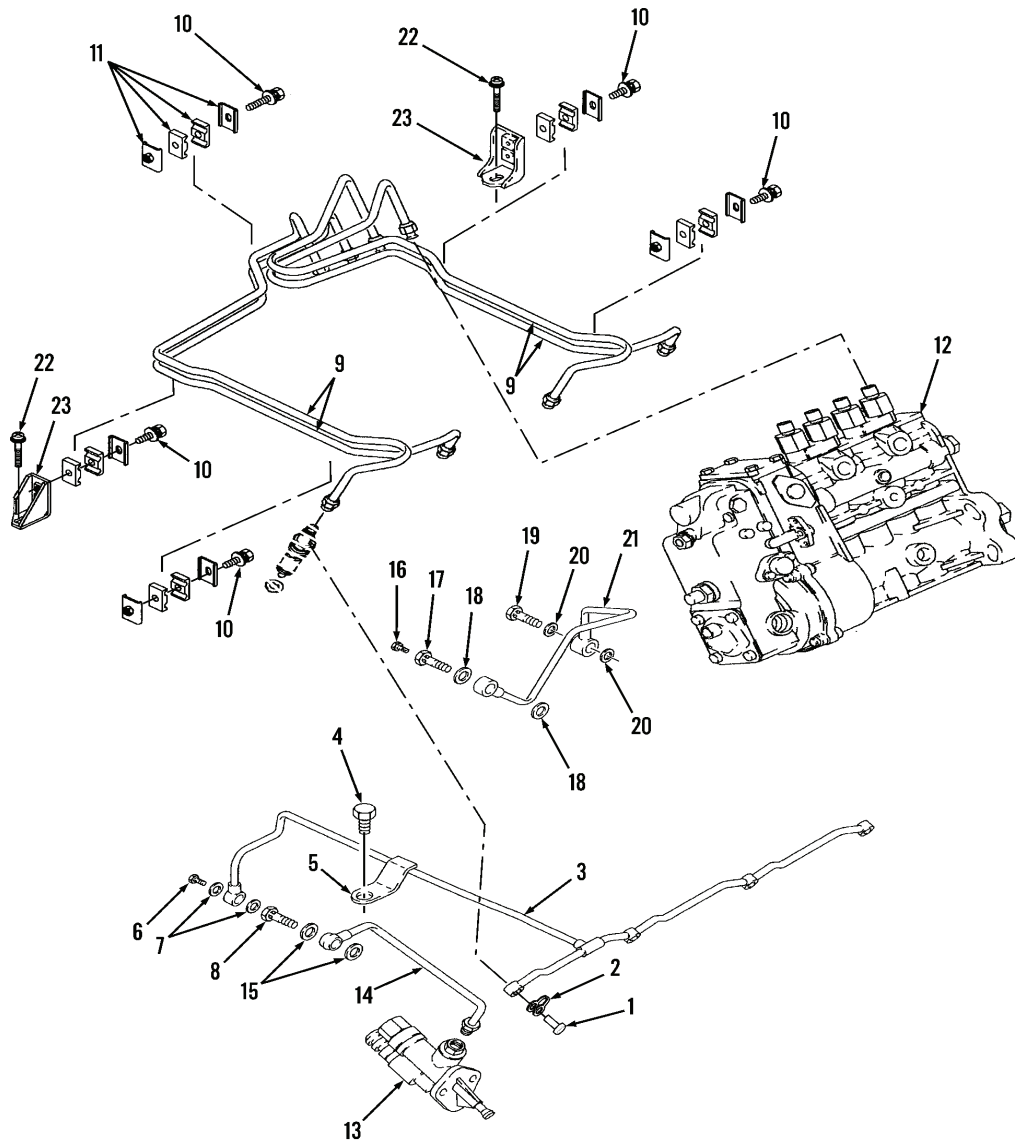

444-0213

**Figure 1. Fuel Injection Lines and Fittings.**

**END OF TASK**

**INSPECTION**

1. Inspect tubes (Figure 2, Items 3, 9, 14, and 21). Replace if cracked, kinked, dented, split, or if inlet fittings damaged.
2. Inspect all other parts. Replace if cracked, damaged, or threads worn.

**END OF TASK****INSTALLATION/REPLACEMENT**

1. Position two mounts (Figure 2, Item 23) on intake manifold and install two bolts (Figure 2, Item 22). Tighten bolts to 30 lb-ft (41 Nm).
2. Position fuel pump inlet tube (Figure 2, Item 21) on fuel injection pump (Figure 2, Item 12) and install bleed screw (Figure 2, Item 19), two washers (Figure 2, Item 20), and fuel pump inlet tube. Tighten bleed screw to 15 to 30 lb-ft (20 to 27 Nm).
3. Install bolt (Figure 2, Item 16), bleed screw (Figure 2, Item 17), and two washers (Figure 2, Item 18) on fuel pump inlet tube (Figure 2, Item 21). Tighten bolt to 15 to 30 lb-ft (20 to 27 Nm).
4. Position fuel pump tube (Figure 2, Item 14) between fuel filter and fuel pump (Figure 2, Item 13).
5. Install bleed screw (Figure 2, Item 8) and two washers (Figure 2, Item 15) on fuel pump tube (Figure 2, Item 14). Tighten bleed screw to 15 to 20 lb-ft (20 to 27 Nm).
6. Connect outlet fitting on fuel pump tube (Figure 2, Item 14) to fuel pump (Figure 2, Item 13) and tighten.
7. Position fuel injection tubes (Figure 2, Item 9) on engine.
8. Connect four outlet fittings on fuel injection tubes (Figure 2, Item 9) to fuel injection pump (Figure 2, Item 12) and tighten.
9. Install five clamp assemblies (Figure 2, Item 11) on cylinder head with five clamp bolts (Figure 2, Item 10).
10. Connect four inlet fittings on fuel tubes (Figure 2, Item 9) to fuel injection inlet fittings. Do not fully tighten until after leak test.
11. Position leak-off tube (Figure 2, Item 3) on bleed screw (Figure 2, Item 8).
12. Install screw (Figure 2, Item 6) and two washers (Figure 2, Item 7) on bleed screw (Figure 2, Item 8) and tighten screw.
13. Install bolt (Figure 2, Item 4) on clamp (Figure 2, Item 5).
14. Install four screws (Figure 2, Item 1) and seals (Figure 2, Item 2) on leak-off tube (Figure 2, Item 3). Tighten screws to 4 to 5 lb-ft (5 to 7 Nm).

**END OF TASK**



**LEAK TEST**

1. Crank engine with starter until fuel flows from inlet fitting on injection tubes (Figure 2, Item 9).
2. Tighten inlet fitting on injection tubes (Figure 2, Item 9).
3. Start engine and check for leaks. Tighten fittings as necessary.

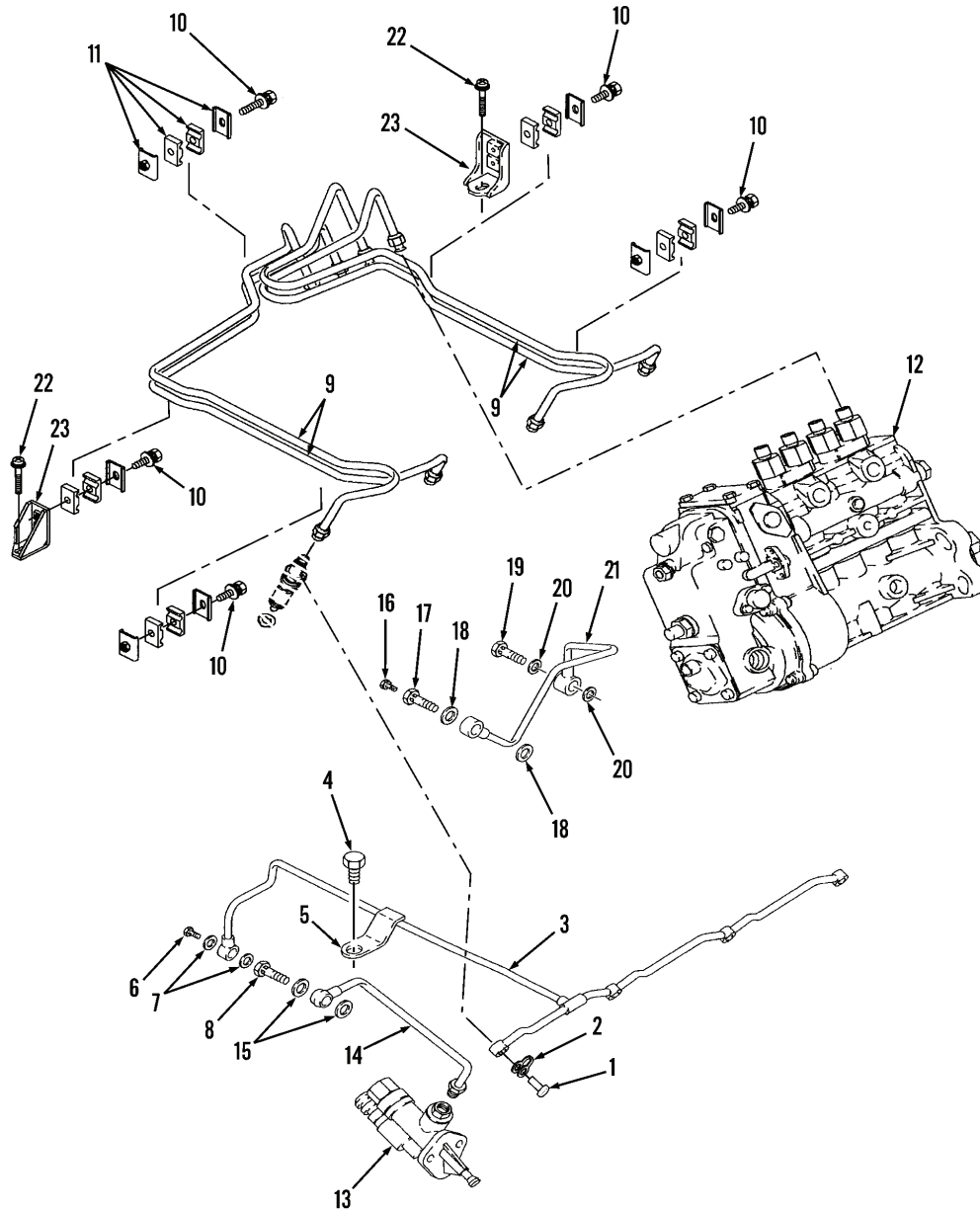

**Figure 2. Fuel Injection Lines and Fittings.**

444-0213

**END OF TASK**

**END OF WORK PACKAGE**



---

## DIRECT SUPPORT MAINTENANCE INSTRUCTIONS

### FUEL INJECTOR REPLACEMENT (MODEL 207)

#### Removal, Cleaning, Installation

---

#### INITIAL SETUP

##### Maintenance Level

Direct Support

##### Tools and Special Tools

Tool kit, general mechanic's (Item 15, WP 0309)

Bore cleaner (P/N A43277)

Nozzle puller (P/N A43278)

##### Materials/Parts

Cleaning compound, solvent (Item 10, WP 0310)

##### Equipment Condition

Vehicle parked on level surface

Engine OFF

Parking brake applied

Left and right side panels removed (WP 0179)

Fuel injector leak-off and injection tubes disconnected (WP 0229)

---

#### REMOVAL

#### NOTE

Perform steps 1 through 3 to remove each of four fuel injectors from engine.

1. At top of engine cylinder head, remove clamp assembly and spacer from fuel injector (Figure 1, Item 3).

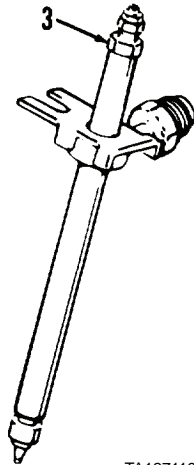

TA127119

Figure 1. Fuel Injector.

**REMOVAL - CONTINUED****CAUTION**

Do not attempt to remove fuel injector by prying with any type of tool. Doing so will damage fuel injector.

2. Pull upward, rotate, and remove fuel injector (Figure 2, Item 3).
3. If fuel injector (Figure 2, Item 3) cannot be easily removed by hand, use nozzle puller tool as shown.

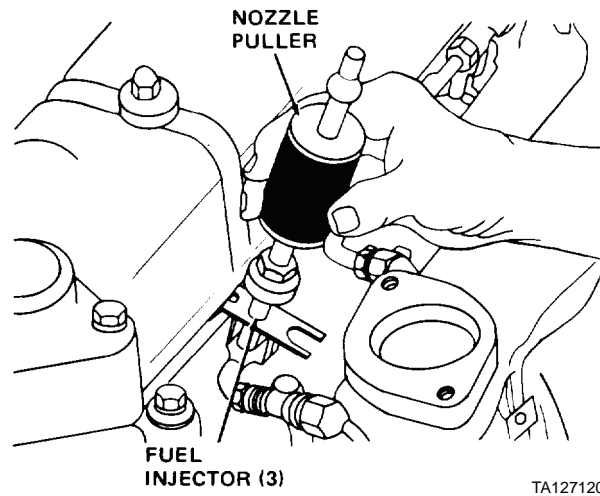

**Figure 2. Puller Tool.**

**END OF TASK**

**CLEANING**

- Solvent cleaning compound MIL-PRF-680 Type III is an environmentally compliant and low toxic material. However, it may be irritating to the eyes and skin. Use protective gloves and goggles. Use in well-ventilated areas. Keep away from open flames and other sources of ignition. Failure to do so may result in injury or death to personnel.
- Particles blown by compressed air are hazardous. **DO NOT** exceed 30 PSI (207 kPa) nozzle pressure when cleaning parts with compressed air. **DO NOT** direct compressed air against human skin. Make sure air stream is directed away from user and other personnel in the area. To prevent injury, user must wear protective goggles or face shield. Failure to follow this warning may result in injury to personnel.

1. Clean sealing surface of cylinder head with solvent cleaning compound. Ensure all particles of dirt and all burrs that could distort fuel injectors are removed. Dry thoroughly.
2. Clean each of four cylinder head bores with bore cleaning tool (Figure 3). Gradually rotate tool into bore clockwise, then remove tool.

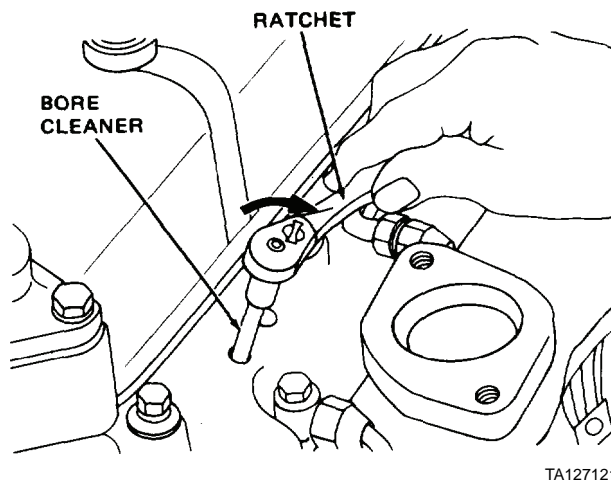

TA127121

**Figure 3. Bore Cleaner Tool.**

3. Clean bore with compressed air.

**END OF TASK**

**INSTALLATION****NOTE**

Perform steps 1 and 2 to install each of four fuel injectors on engine.

1. Install fuel injector (Figure 4, Item 3) in engine cylinder head using a twisting motion until locking plate of fuel injector contacts cylinder head.

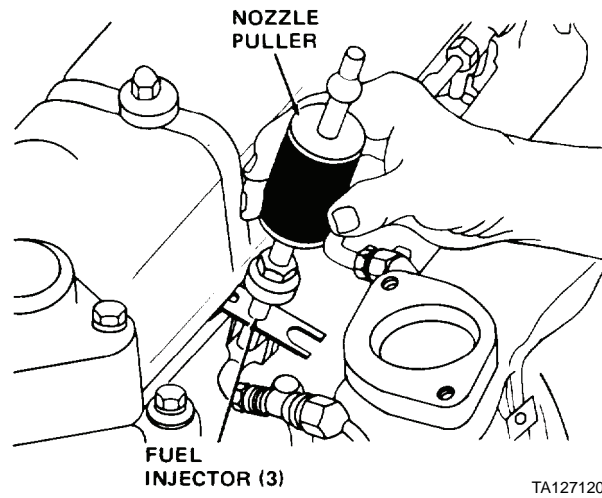

**Figure 4. Installing Fuel Injector.**

2. Install clamp assembly and spacer. Tighten bolt of clamp assembly to 18 to 22 lb-ft (24 to 30 Nm).

**END OF TASK**

**END OF WORK PACKAGE**

---

## DIRECT SUPPORT MAINTENANCE INSTRUCTIONS

### FUEL INJECTOR MAINTENANCE (MODEL 4-390)

Removal, Cleaning, Installation, Leak Test

---

#### INITIAL SETUP

##### Maintenance Level

Direct Support

##### Tools and Special Tools

Tool kit, general mechanic's (Item 15, WP 0309)  
Adapter, torque wrench (NSN 5120-00-018-1523,  
P/N CAS 1066A)  
Bore cleaner (P/N CAS-1694 or CAS-2155)  
Wrench, torque

##### Materials/Parts

Cleaning compound, solvent (Item 10, WP 0310)  
Rag, wiping (Item 26, WP 0310)  
Seal (3)

##### Equipment Condition

Vehicle parked on level surface  
Engine OFF  
Parking brake applied  
Side panels removed (WP 0179)  
Top hood removed (WP 0181)

---

**REMOVAL****NOTE**

Clean area around the fuel injectors.

1. Disconnect fuel injection line (Figure 1, Item 1) and remove seal (Figure 1, Item 2) from fuel injector (Figure 1, Item 3). Discard seal.
2. Remove leak-off bolt (Figure 1, Item 4) and seal (Figure 1, Item 5) and disconnect leak-off tube (Figure 1, Item 6) from fuel injector (Figure 1, Item 3). Discard seal.
3. Remove fuel injector (Figure 1, Item 3) and seal (Figure 1, Item 7) from cylinder head (Figure 1, Item 8) using ratchet and torque wrench adapter. Discard seal.

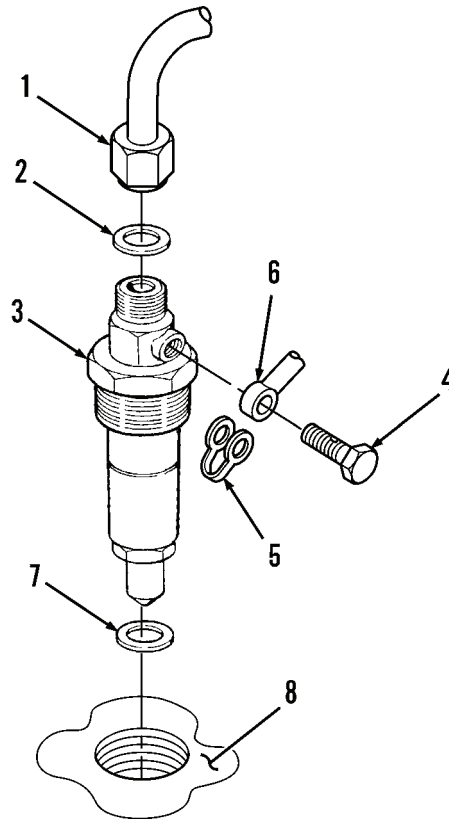

444-0156

**Figure 1. Fuel Injector.**

**END OF TASK**



## CLEANING



WARNING

- Solvent cleaning compound MIL-PRF-680 Type III is an environmentally compliant and low toxic material. However, it may be irritating to the eyes and skin. Use protective gloves and goggles. Use in well-ventilated areas. Keep away from open flames and other sources of ignition. Failure to do so may result in injury or death to personnel.
  - Particles blown by compressed air are hazardous. DO NOT exceed 30 PSI (207 kPa) nozzle pressure when cleaning parts with compressed air. DO NOT direct compressed air against human skin. Make sure air stream is directed away from user and other personnel in the area. To prevent injury, user must wear protective goggles or face shield. Failure to follow this warning may result in injury to personnel.
1. Use solvent cleaning compound to clean cylinder head fuel injector seal surfaces and dry thoroughly. Remove all dirt and burrs which could cause distortion of fuel injector when installing.
  2. Use bore cleaning tool to clean cylinder head fuel injector bore as shown (Figure 2). Gradually turn tool into bore using clockwise rotation; then remove tool and blow out bore with compressed air.

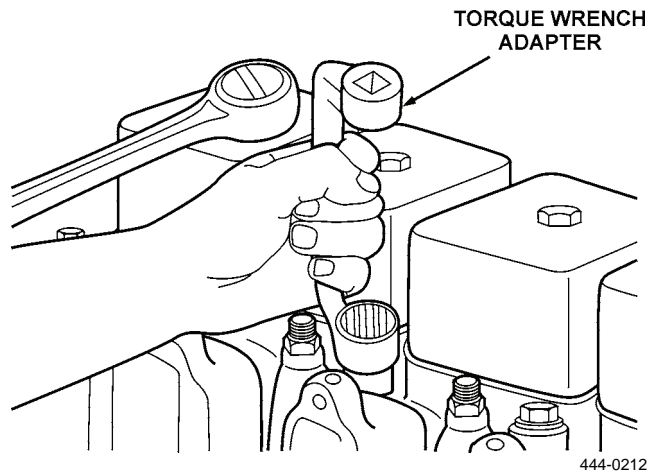

Figure 2. Cleaning Fuel Injector Bore.

END OF TASK

**INSTALLATION****NOTE**

Ball on fuel injector must align with slot in cylinder head bore.

1. Install new seal (Figure 3, Item 7) and fuel injector (Figure 3, Item 3) in bore of cylinder head (Figure 3, Item 8). Use torque wrench adapter to tighten fuel injector to 41 to 44 lb-ft (56 to 60 Nm).
2. Install new seal (Figure 3, Item 2) and connect fuel injector line (Figure 3, Item 1) to fuel injector (Figure 3, Item 3). Do not fully tighten line.
3. Connect leak-off tube (Figure 3, Item 6) to fuel injector (Figure 3, Item 3) and install new seal (Figure 3, Item 5) and leak-off bolt (Figure 3, Item 4). Tighten leak-off bolt to 71 lb-in. (8 Nm).

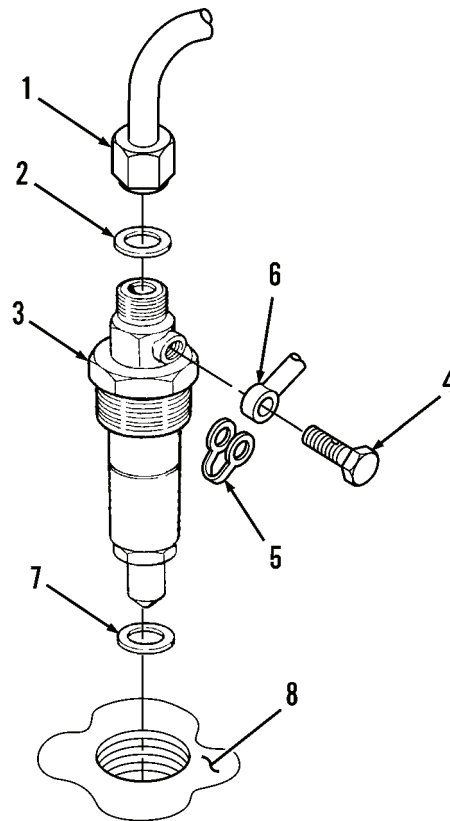

444-0156

**Figure 3. Fuel Injector.**

**END OF TASK****LEAK TEST**

1. Crank engine with starter until fuel flows from inlet fittings on injection lines (Figure 3, Item 1).
2. Tighten inlet fittings on injection lines (Figure 3, Item 1).
3. Start engine and check for leaks. Tighten fittings as necessary.

**END OF TASK****END OF WORK PACKAGE**

---

## DIRECT SUPPORT MAINTENANCE INSTRUCTIONS

### FUEL INJECTION PUMP REPLACEMENT (MODEL 207)

#### Removal, Cleaning, Inspection, Installation

---

#### INITIAL SETUP

##### Maintenance Level

Direct Support

##### Tools and Special Tools

Tool kit, general mechanic's (Item 15, WP 0309)

Dial indicator

Sleeve tool (P/N CD322)

Spring tester (P/N CAS-10418)

##### Materials/Parts

Cleaning compound, solvent (Item 10, WP 0310)

Cloth, crocus (Item 12, WP 0310)

Lubriplate (Item 23, WP 0310)

Rag, wiping (Item 26, WP 0310)

Gear housing cover plate gasket

Injection pump O-ring

Lockwasher

Pump drive shaft seals (2)

##### Materials/Parts - Continued

Pump window cover gasket

##### References

WP 0208

##### Equipment Condition

Vehicle parked on level surface

Engine OFF

Parking brake applied

Side panels removed (WP 0179)

Fuel tank shut-off valve closed

Fuel filters and filter head removed (WP 0069)

Injection pump fuel lines and fittings disconnected  
(WP 0229)

Engine positioned at TDC for No. 1 cylinder (WP  
0204)

Accelerator ball joint and cable disconnected from  
fuel injection pump (WP 0074)

---

**REMOVAL****NOTE**

If same injection pump is to be reinstalled, scribe small matchmarks on injection pump flange and timing gear housing to aid in installation.

1. While supporting fuel injection pump (Figure 1, Item 3), remove three nuts (Figure 1, Item 1), and washers (Figure 1, Item 2).
2. Carefully remove fuel injection pump (Figure 1, Item 3) from engine and drive shaft (Figure 1, Item 15). Remove and discard O-ring (Figure 1, Item 4).
3. Remove two seals (Figure 1, Item 5) from drive shaft (Figure 1, Item 15). Discard seals.

**NOTE**

The following steps cover removal of drive shaft and drive gear. If fuel injection pump is to be replaced, drive shaft must be forwarded to General Support Maintenance with defective pump.

4. At timing gear housing of engine, remove seven capscrews (Figure 1, Item 6), two nuts (Figure 1, Item 7), cover plate (Figure 1, Item 8), and gasket (Figure 1, Item 9). Discard gasket.
5. Remove thrust plunger (Figure 1, Item 10), spring (Figure 1, Item 11), nut (Figure 1, Item 12), and lockwasher (Figure 1, Item 13). Discard lockwasher.
6. Remove drive gear (Figure 1, Item 14) from drive shaft (Figure 1, Item 15).

**NOTE**

Replacement drive shaft includes roll pin. Perform step 7 only if roll pin is sheared and drive shaft is not damaged.

7. Remove roll pin (Figure 1, Item 16) from drive shaft (Figure 1, Item 15). Use 3/32 in. drift to push out, or carbide-tipped drill bit to drill out.

## REMOVAL - CONTINUED

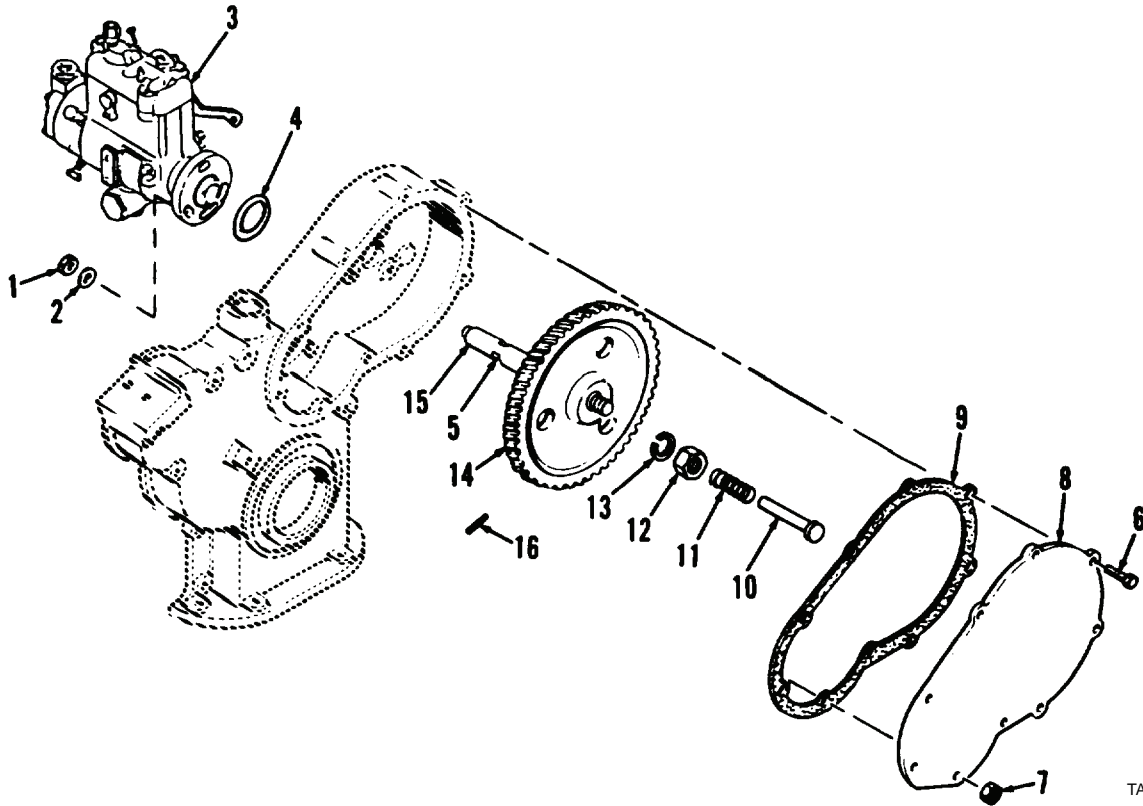

TA127122

Figure 1. Fuel Injection Pump and Drive Shaft.

## END OF TASK

## CLEANING



## WARNING



- Solvent cleaning compound MIL-PRF-680 Type III is an environmentally compliant and low toxic material. However, it may be irritating to the eyes and skin. Use protective gloves and goggles. Use in well-ventilated areas. Keep away from open flames and other sources of ignition. Failure to do so may result in injury or death to personnel.
- Particles blown by compressed air are hazardous. DO NOT exceed 15 PSI (103 kPa) nozzle pressure when drying parts with compressed air. DO NOT direct compressed air against human skin. Make sure air stream is directed away from user and other personnel in the area. To prevent injury, user must wear protective goggles or face shield. Failure to follow this warning may result in injury to personnel.

1. Clean exterior of fuel injection pump by wiping with clean rag moistened with solvent cleaning compound.
2. Clean all other parts with solvent cleaning compound. Dry with compressed air.

## END OF TASK

**INSPECTION**

1. Inspect drive gear (Figure 2, Item 14). Replace if gear teeth are excessively worn, pitted, broken, or missing.
2. Inspect drive shaft (Figure 2, Item 15). Replace if bent, pitted, or excessively worn.
3. Inspect spring (Figure 2, Item 11). Install in spring tester. Ensure force to compress spring to 0.95 in. (24 mm) is 6 lb, 4 oz (2.83 kg), and that free length is 1.22 in. (31 mm). Replace spring if above specifications are not met, or if coils are distorted or broken.
4. Inspect thrust plunger (Figure 2, Item 10). Replace if cracked, bent, or excessively worn.
5. Inspect cover plate (Figure 2, Item 8). Replace if cracked or damaged.
6. Inspect flange of fuel injection pump (Figure 2, Item 3) and mating surface of timing gear housing. Use fine stone or crocus cloth to remove any nicks or burrs from mating surfaces.

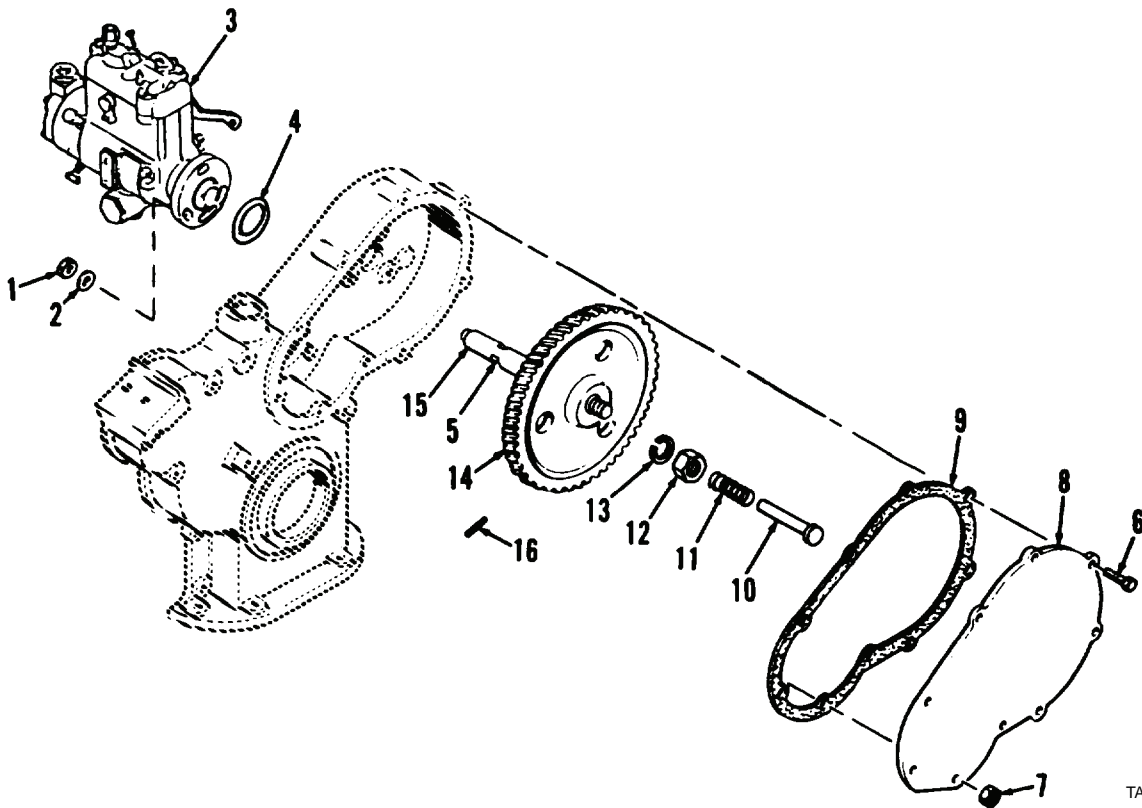

Figure 2. Fuel Injection Pump and Drive Shaft.

END OF TASK

## INSTALLATION

### NOTE

Replacement drive shaft includes roll pin. Perform steps 1 and 2 if only the roll pin requires replacement.

1. Use P/N 138-275 roll pin (Figure 2, Item 16) and grind flat on one end to 0.185 to 0.200 in. (4.70 to 5.08 mm) overall length as shown (Figure 3).

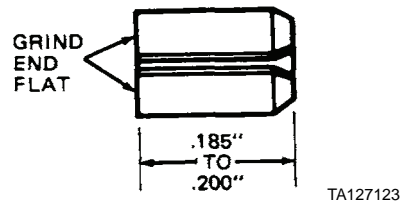

Figure 3. Roll Pin.

2. Press fabricated roll pin (Figure 2, Item 16) into drive shaft (Figure 2, Item 15), chamfered end first, to 0.065 to 0.075 in. (1.65 to 1.91 mm) dimension as shown (Figure 4).

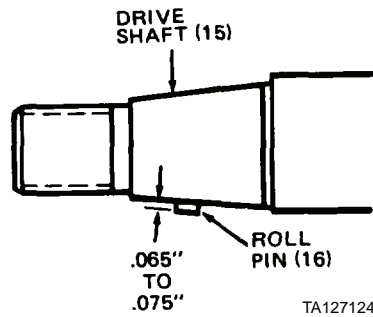

Figure 4. Roll Pin Installation.

3. Install drive shaft (Figure 2, Item 15) on large hub side of drive gear (Figure 2, Item 14).
4. Position drive shaft (Figure 2, Item 15) and drive gear (Figure 2, Item 14) assembly in timing gear housing. Align timing mark on drive gear with timing pointer on idler gear as shown (Figure 5).

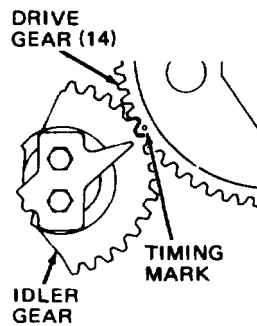
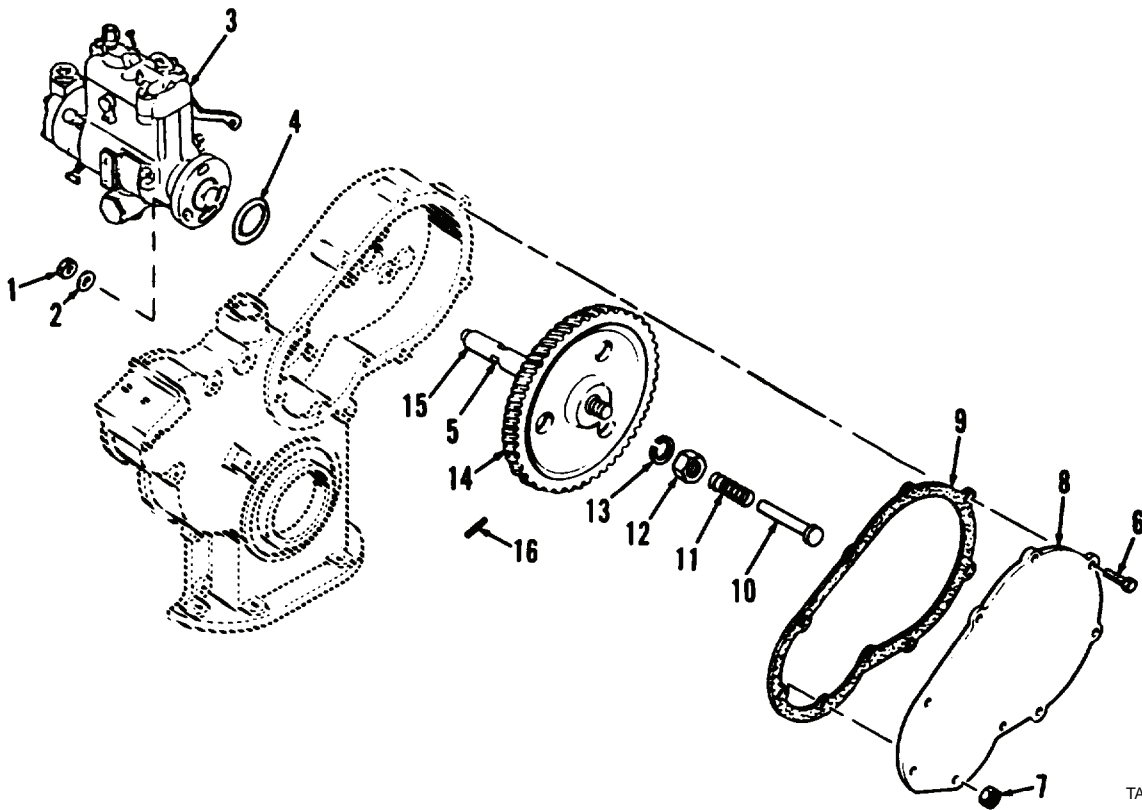

Figure 5. Aligning Timing Mark.

**INSTALLATION - CONTINUED**

5. Install new lockwasher (Figure 6, Item 13) and nut (Figure 6, Item 12) on drive shaft (Figure 6, Item 15). Tighten nut to 40 to 50 lb-ft (54 to 68 Nm).
6. Check backlash of drive gear (Figure 6, Item 14). Using dial indicator on one tooth of drive gear, measure drive gear-to-idler gear backlash. If backlash exceeds 0.007 in. (0.18 mm), install new drive gear and recheck. If backlash still exceeds 0.007 in. (0.18 mm), replace idler gear (notify General Support Maintenance).
7. Install spring (Figure 6, Item 11) and thrust plunger (Figure 6, Item 10) in bore of drive shaft (Figure 6, Item 15). Make sure plunger is free to move in bore of drive shaft.
8. Position new gasket (Figure 6, Item 9) and cover plate (Figure 6, Item 8) on timing gear housing.
9. Install seven cap screws (Figure 6, Item 6) and two nuts (Figure 6, Item 7). Tighten capscrews and nuts to 25 to 30 lb-ft (34 to 41 Nm).



TA127122

**Figure 6. Fuel Injection Pump and Drive Shaft.**



**INSTALLATION - CONTINUED**

10. Install two new seals (Figure 7, Item 5) on drive shaft (Figure 7, Item 15). Generously lubricate seals with lubriplate. Install seals on sleeve tool with lips of seals outward (seals back-to-back as shown in Figure 7), then slide sleeve tool over drive shaft and position seals in grooves of drive shaft.

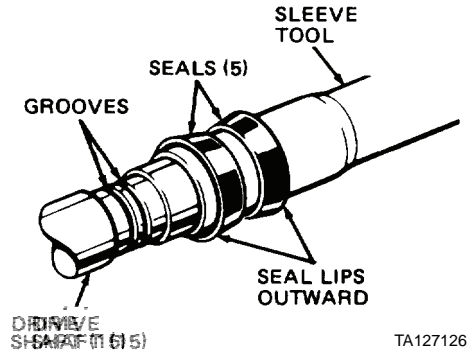

**Figure 7. Installing Seals.**

TA127126

**NOTE**

If engine has been cranked after removing fuel injection pump, reposition engine at TDC for No. 1 cylinder (WP 0204).

11. Position new O-ring (Figure 6, Item 4) on flange of fuel injection pump (Figure 6, Item 3).
12. At timing window of fuel injection pump (Figure 6, Item 3), remove two screws, cover, and gasket.
13. Position rotor of fuel injection pump (Figure 6, Item 3). Using a clean, wide-bladed screwdriver at drive end of injection pump, rotate pump rotor to approximate position of aligning hole of tang on drive shaft as shown (Figure 8, Item 15). Then, rotate pump rotor until timing lines in pump window are aligned.

**NOTE**

If holes on drive shaft tang and pump rotor are not aligned, pump will be 180 degrees out of time.

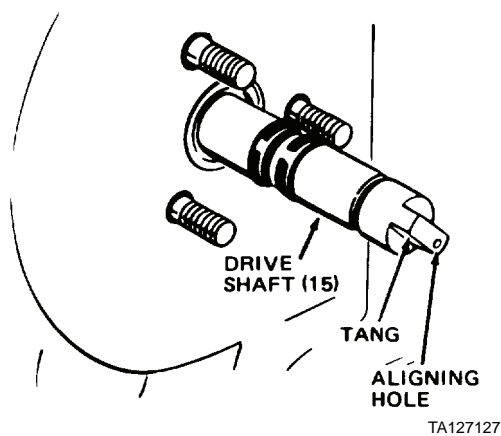
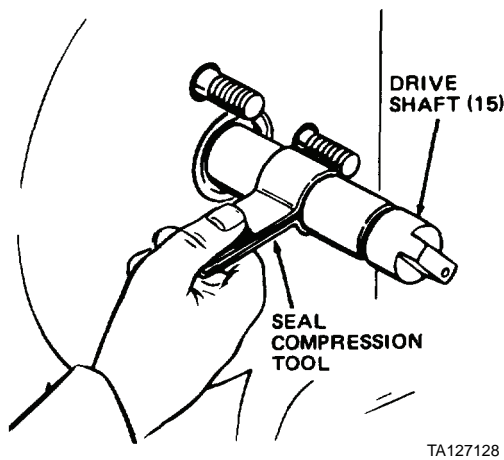

**Figure 8. Aligning Drive Shaft.**

TA127127

**INSTALLATION - CONTINUED**

14. Using a seal compression tool, as shown in Figure 9, compress two seals.



**Figure 9. Using Seal Compression Tool.**

15. Position fuel injection pump (Figure 10, Item 3) on timing gear housing. While still compressing seals (Figure 10, Item 5) with compression tool, slide fuel injection pump onto drive shaft (Figure 10, Item 15) and over seals; then, remove compression tool and slide pump against timing gear housing. After compression tool is removed, it may be necessary to rotate pump body slightly to permit tang of drive shaft to engage slot in injection pump.

**NOTE**

If rear seal is rolled over on drive shaft during installation, remove fuel injection pump and replace rear seal even though no visual damage is apparent.

16. Install fuel injection pump (Figure 10, Item 3) with three washers (Figure 10, Item 2) and nuts (Figure 10, Item 1). Hand-tighten nuts.
17. Connect injection pump fuel lines and fittings (WP 0229).
18. Connect accelerator ball joint and cable to fuel injection pump (WP 0074).
19. Install fuel filters and filter head (WP 0069).
20. Check and adjust timing, engine idle speed, and no-load governed speed (WP 0208).

INSTALLATION - CONTINUED

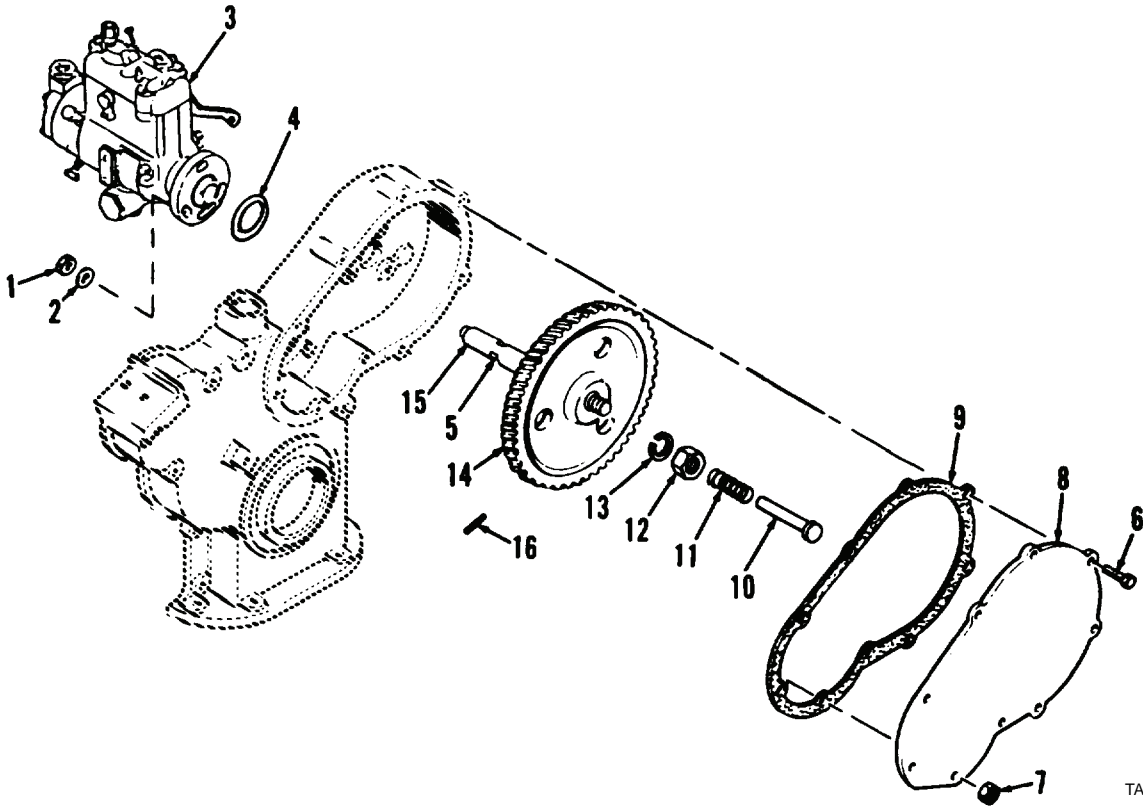

TA127122

Figure 10. Fuel Injection Pump and Drive Shaft.

END OF TASK

END OF WORK PACKAGE



---

## DIRECT SUPPORT MAINTENANCE INSTRUCTIONS

### FUEL INJECTION PUMP REPLACEMENT (MODEL 4-390)

Removal, Cleaning, Inspection, Installation

---

#### INITIAL SETUP

**Maintenance Level**

Direct Support

**Tools and Special Tools**

Tool kit, general mechanic's (Item 15, WP 0309)

Gear puller (CAS-1691A)

**Materials/Parts**

Cap set, protective (Item 9, WP 0310)

Cleaning compound, solvent (Item 10, WP 0310)

Rag, wiping (Item 26, WP 0310)

Copper washer (2)

Gear housing cover plate seal

Injection pump O-ring

**References**

WP 0184

**Equipment Condition**

Vehicle parked on level surface

Engine OFF

Parking brake applied

Left and right side panels removed (WP 0179)

Injection pump fuel lines and fittings disconnected  
(WP 0230)

Engine positioned at TDC for No. 1 cylinder (WP  
0205)

Accelerator ball joint and cable disconnected from  
fuel injection pump (WP 0075)

---

## REMOVAL

## NOTE

- Clean engine before any service work is done on fuel system.
  - Cap and plug all openings, hoses, and lines after disconnection.
1. Remove cover (Figure 1, Item 1) and seal (Figure 1, Item 2). Discard seal.
  2. Remove nut (Figure 1, Item 3) and washer (Figure 1, Item 4) from fuel injection pump shaft.

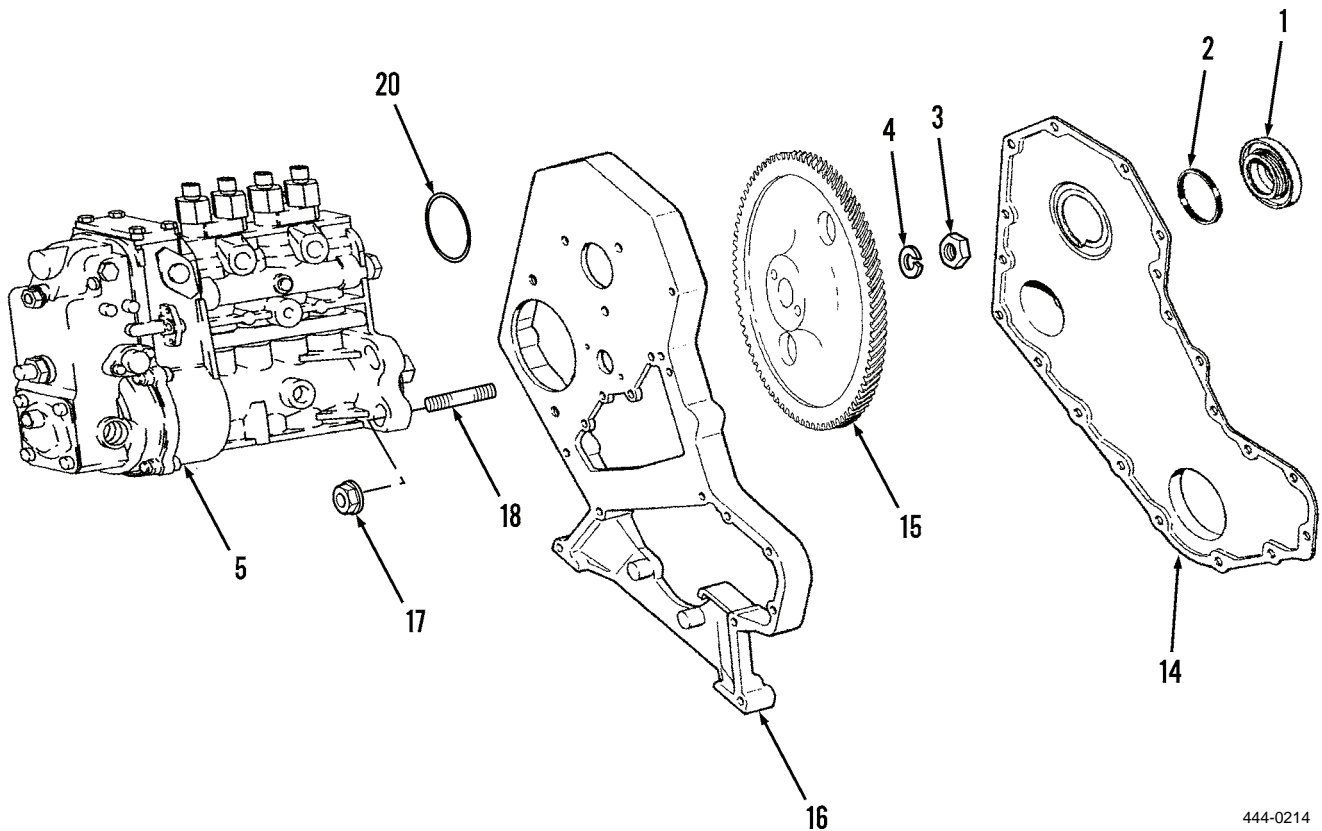

444-0214

**Figure 1. Fuel Injection Pump and Engine Cover.**

3. Remove bleed screw (Figure 2, Item 6) and two copper washers (Figure 2, Item 7) from fuel injection pump (Figure 2, Item 5).
4. Remove fuel tank return hose (Figure 2, Item 8) from engine.

REMOVAL - CONTINUED

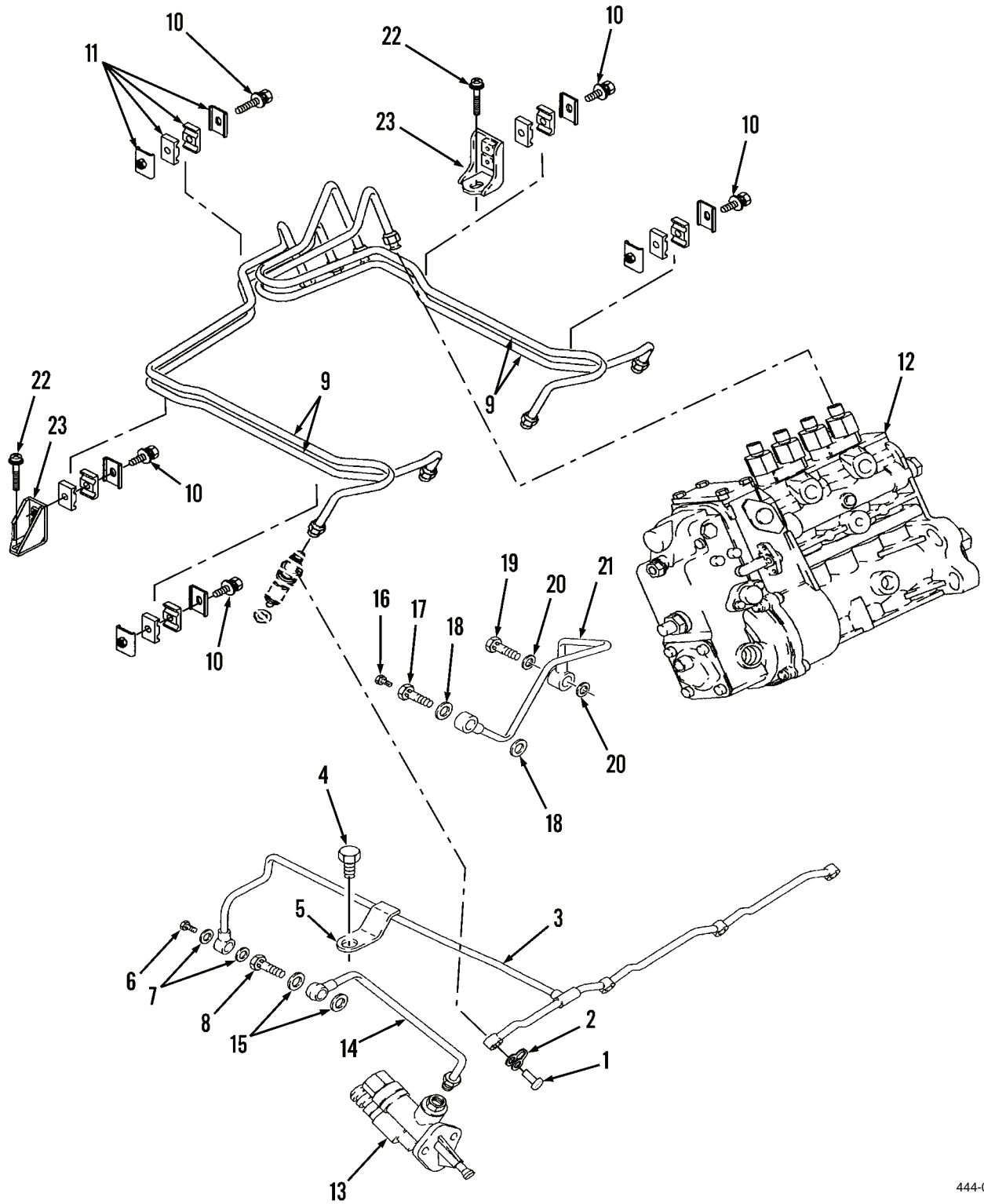
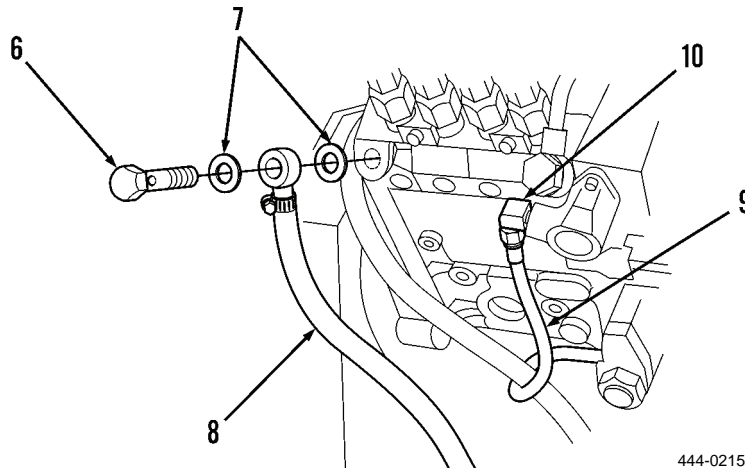

Figure 2. Fuel Lines and Fittings.

444-0213

**REMOVAL - CONTINUED**

5. Remove lubrication line (Figure 3, Item 9) and fitting (Figure 3, Item 10).



**Figure 3. Return Hose and Lubrication Line.**

6. Bend tab of locking clip (Figure 4, Item 11) away from cover (Figure 4, Item 12).
7. Remove cover (Figure 4, Item 12) and timing pin (Figure 4, Item 13). If timing tooth is not aligned in timing pin hole, rotate pump shaft until timing tooth is aligned.

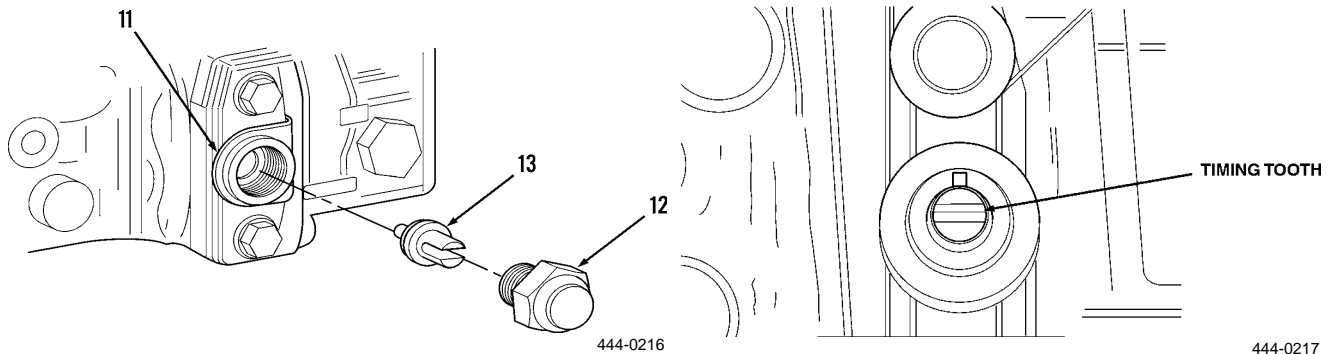

**Figure 4. Timing Pin and Timing Tooth.**

8. Turn timing pin (Figure 5, Item 13) around and install in timing pin hole. Slot on timing pin must align with timing tooth.

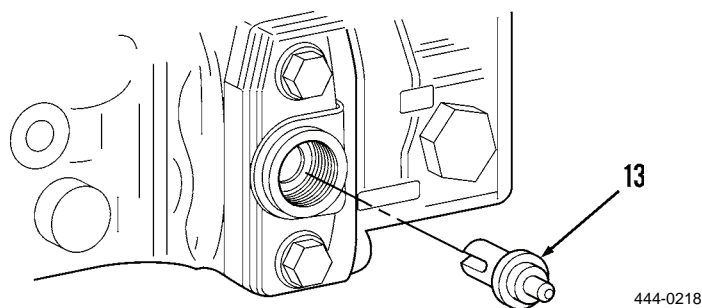
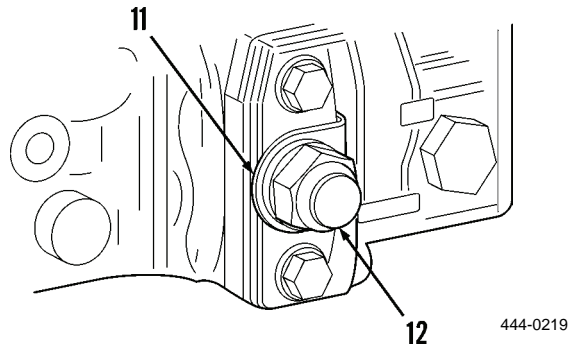

**Figure 5. Timing Pin.**



**REMOVAL - CONTINUED**

9. Install cover (Figure 6, Item 12) finger-tight. No need to bend tab of locking clip (Figure 6, Item 11).



**Figure 6. Cover.**

10. Loosen pump gear in front cover (Figure 7, Item 14). Use gear puller to loosen pump gear from pump shaft.

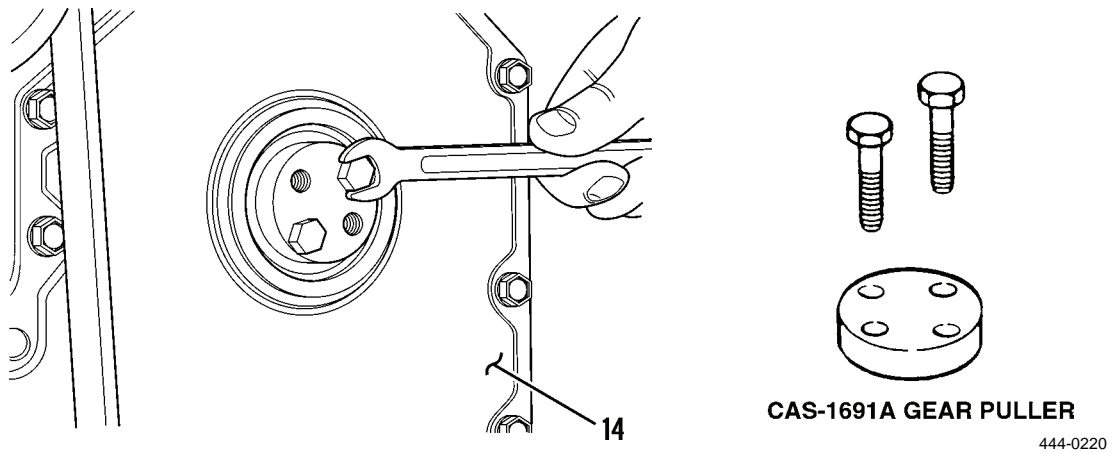

**Figure 7. Using Gear Puller Tool.**

**REMOVAL - CONTINUED**

11. Remove three nuts (Figure 8, Item 17) and studs (Figure 8, Item 18) from front housing (Figure 8, Item 16).
12. Remove fuel injection pump (Figure 8, Item 5) from engine.
13. Remove O-ring (Figure 8, Item 20) from fuel injection pump (Figure 8, Item 5). Discard O-ring.

**NOTE**

To remove pump gear from vehicle, remove front cover (WP 0184).

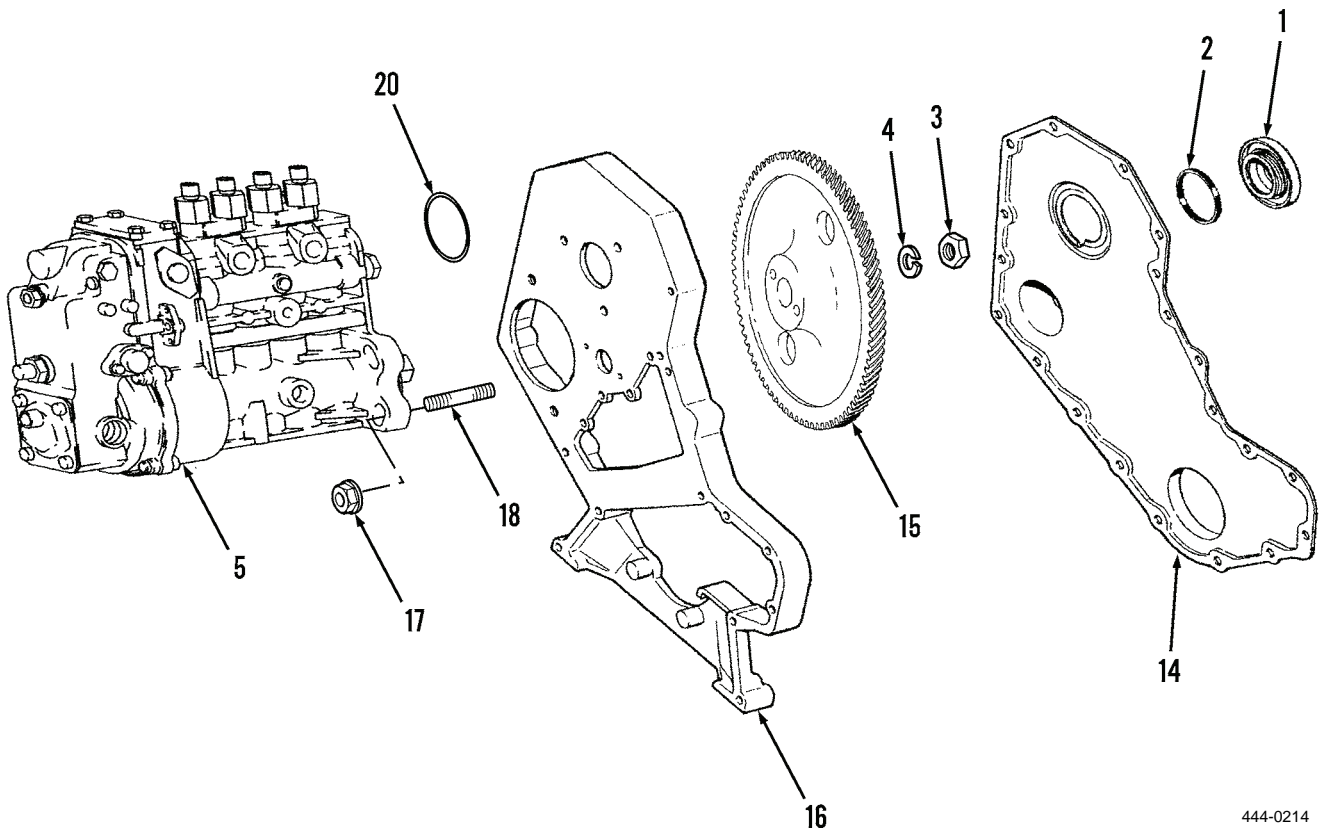

444-0214

Figure 8. Fuel Injection Pump and Engine Cover.

**CLEANING****WARNING**

- Solvent cleaning compound MIL-PRF-680 Type III is an environmentally compliant and low toxic material. However, it may be irritating to the eyes and skin. Use protective gloves and goggles. Use in well-ventilated areas. Keep away from open flames and other sources of ignition. Failure to do so may result in injury or death to personnel.
  - Particles blown by compressed air are hazardous. **DO NOT** exceed 15 PSI (103 kPa) nozzle pressure when drying parts with compressed air. **DO NOT** direct compressed air against human skin. Make sure air stream is directed away from user and other personnel in the area. To prevent injury, user must wear protective goggles or face shield. Failure to follow this warning may result in injury to personnel.
1. Use solvent cleaning compound to clean pump shaft and pump gear tapers.
  2. Dry pump gear taper with compressed air.

**END OF TASK****INSPECTION**

1. Inspect pump gear (Figure 8, Item 15). Replace if cracked or excessively worn.
2. Inspect fuel injection pump (Figure 8, Item 5). Replace if damaged.

**END OF TASK****INSTALLATION**

1. Install new O-ring (Figure 8, Item 20) on fuel injection pump (Figure 8, Item 5).
2. Install fuel injection pump (Figure 8, Item 5), three studs (Figure 8, Item 18), and nuts (Figure 8, Item 17) on front housing (Figure 8, Item 16). Tighten nuts to 29 to 35 lb-ft (39 to 47 Nm).
3. Install pump gear (Figure 8, Item 15), washer (Figure 8, Item 4), and nut (Figure 8, Item 3) on front cover (Figure 8, Item 14). Tighten nut securely but not to specification.

**INSTALLATION - CONTINUED**

4. Remove cover timing pin (Figure 9, Item 13) from fuel injection pump.
5. Install timing pin (Figure 9, Item 13) with notched end facing out.
6. Install cover (Figure 9, Item 12). Tighten cover to 10 to 13 lb-ft (14 to 18 Nm).

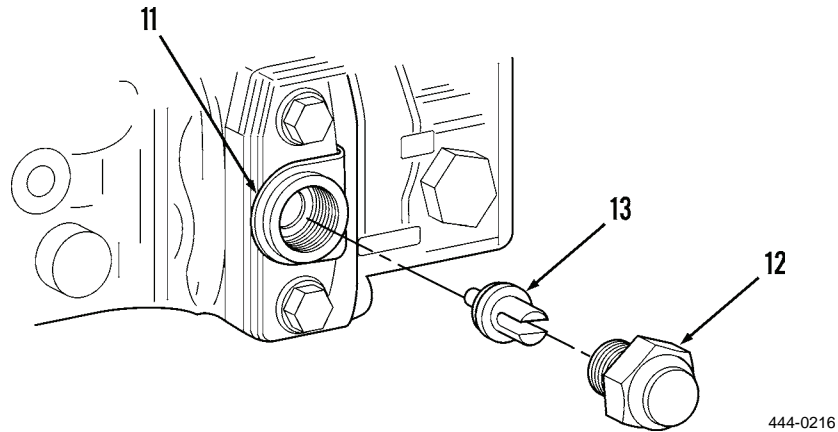

**Figure 9. Timing Pin and Cover.**

7. Install fitting (Figure 10, Item 10) and lubrication line (Figure 10, Item 9) on fuel injection pump (Figure 10, Item 5).
8. Position fuel tank return hose (Figure 10, Item 8) and install two copper washers (Figure 10, Item 7) and bleed screw (Figure 10, Item 6).

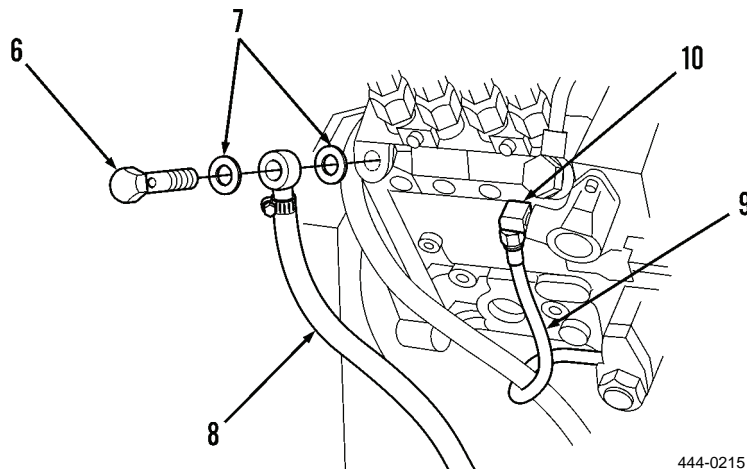

**Figure 10. Return Hose and Lubrication Line.**

9. Pull outward on lockpin of engine (WP 0205).
10. Tighten nut installed in step 3 to 63 to 74 lb-ft (85 to 100 Nm).
11. Reset top dead center (TDC) (WP 0205).

**END OF TASK****END OF WORK PACKAGE**

## DIRECT SUPPORT MAINTENANCE INSTRUCTIONS

### RADIATOR AND SHROUD REPAIR (MODEL 207)

#### Cleaning, Inspection/Repair

#### INITIAL SETUP

##### Maintenance Level

Direct Support

##### Tools and Special Tools

Tool kit, general mechanic's (Item 15, WP 0309)

##### Materials/Parts

Cleaning compound, solvent (Item 10, WP 0310)

Detergent, liquid (Item 13, WP 0310)

##### Materials/Parts - Continued

Paint, black (Item 24, WP 0310)

Rag, wiping (Item 26, WP 0310)

##### References

WP 0009

##### Equipment Condition

Radiator and shroud removed (WP 0082)

#### CLEANING

1. Use general purpose liquid detergent and water to clean radiator, then rinse radiator thoroughly.



WARNING



Solvent cleaning compound MIL-PRF-680 Type III is an environmentally compliant and low toxic material. However, it may be irritating to the eyes and skin. Use protective gloves and goggles. Use in well-ventilated areas. Keep away from open flames and other sources of ignition. Failure to do so may result in injury or death to personnel.

2. Use solvent cleaning compound to clean radiator exterior and cooling fins. Dry thoroughly and rinse with clear water to remove all traces of solvent cleaning compound.

#### END OF TASK

**INSPECTION/REPAIR**

1. Inspect radiator shroud and repair broken welds and cracks by welding.

**CAUTION**

Be careful not to damage core when straightening bent fins.

2. Inspect cooling fins and core of radiator. Straighten bent fins.

**CAUTION**

Use minimum amount of solder to prevent clogging radiator which could damage equipment.

3. Repair leaking core tubes by soldering.
4. Inspect interior and core. If necessary, repeat step 1 of *Cleaning* in this work package.
5. Inspect tanks, filler neck, brackets, and hose flanges; repair cracked or leaking areas by soldering.
6. Check for leakage (WP 0009, MALFUNCTION 3). Replace radiator if necessary.
7. Use black paint to protect repaired areas of radiator.

**END OF TASK****END OF WORK PACKAGE**

## DIRECT SUPPORT MAINTENANCE INSTRUCTIONS

### RADIATOR AND SHROUD REPAIR (MODEL 4-390)

#### Cleaning, Inspection/Repair

#### INITIAL SETUP

##### Maintenance Level

Direct Support

##### Tools and Special Tools

Tool kit, general mechanic's (Item 15, WP 0309)

##### Materials/Parts

Cleaning compound, solvent (Item 10, WP 0310)

##### Materials/Parts - Continued

Paint, black (Item 24, WP 0310)

Rag, wiping (Item 26, WP 0310)

##### References

WP 0009

##### Equipment Condition

Radiator and shroud removed (WP 0083)

#### CLEANING



**WARNING**



- Use alkaline cleaning compound only in a well-ventilated area. Avoid inhaling of fumes or contact with skin. Failure to do so may result in injury to personnel. If you inhale fumes, get fresh air immediately. If contact with skin or clothes is made, flush with large amounts of water and obtain medical aid immediately.
  - Solvent cleaning compound MIL-PRF-680 Type III is an environmentally compliant and low toxic material. However, it may be irritating to the eyes and skin. Use protective gloves and goggles. Use in well-ventilated areas. Keep away from open flames and other sources of ignition. Failure to do so may result in injury or death to personnel.
1. Use alkaline immersion process with cleaning compound to clean radiator. After cleaning, thoroughly rinse with clear water to remove all traces of cleaning compound.
  2. Radiator exterior and cooling fins may also be cleaned using solvent cleaning compound. Dry thoroughly and rinse with clear water to remove all traces of solvent cleaning compound.

#### END OF TASK

---

**INSPECTION/REPAIR**

1. Inspect radiator shroud. Repair broken welds and cracks by welding. Replace shroud if beyond economical repair.

**CAUTION**

- Be careful not to damage core when straightening bent fins.
  - Use minimum amount of solder to prevent clogging radiator which could damage equipment.
2. Inspect cooling fins and core from radiator. Straighten bent fins, taking care not to damage core. Repair leaking core tubes by soldering, using minimum amount of solder to prevent clogging tubes.
  3. Inspect interior and core. If necessary, repeat step 1 of *Cleaning* in this work package to remove all scale deposits.
  4. Inspect tanks, filler neck, brackets, and hose flanges. Repair cracked or leaking areas by soldering, using minimum amount of solder to prevent clogging radiator.

**NOTE**

After soldering radiator, perform radiator pressure test (WP 0009, MALFUNCTION 3) to check for leakage. Replace radiator if excessively clogged with scale deposits, or if unable to repair by soldering.

5. Paint radiator as soon as possible after pressure test, using black paint to protect repaired areas of radiator.

**END OF TASK****END OF WORK PACKAGE**



---

## DIRECT SUPPORT MAINTENANCE INSTRUCTIONS

### ALTERNATOR REPAIR (MODEL 207)

Disassembly, Cleaning, Inspection, Testing, Assembly

---

#### INITIAL SETUP

##### Maintenance Level

Direct Support

##### Tools and Special Tools

Tool kit, general mechanic's (Item 15, WP 0309)  
Shop equipment, common no. 1 (Item 2, WP 0309)  
Camshaft gear remover (P/N J8810)  
Front cover seal installer (P/N J7584-1)  
Valve guide installer (P/N J5158-2)

##### Materials/Parts

Cleaning compound, solvent (Item 10, WP 0310)  
Rag, wiping (Item 26, WP 0310)  
Tag, marker (Item 33, WP 0310)  
Bearing  
Grease slinger washer  
Lockwasher

##### Equipment Condition

Alternator removed (WP 0093)

---

---

**DISASSEMBLY**

1. Match mark drive end frame (Figure 1, Item 1) and slip ring end frame (Figure 1, Item 2) for correct reassembly.

**CAUTION**

Use extreme caution not to touch stator winding when inserting screwdriver blades and prying frames apart. Do not use hammer to drive frames apart. Damage to equipment may result.

**NOTE**

When separating, work evenly around circumference of frame.

2. Remove four thru bolts (Figure 1, Item 3) from alternator assembly and separate drive end frame (Figure 1, Item 1) and stator and slip ring end frame (Figure 1, Item 2).
3. Remove three nuts (Figure 1, Item 5) from slip ring end frame (Figure 1, Item 2).

**CAUTION**

Use caution when removing stator to avoid damaging stator.

**NOTE**

Tag all electrical leads to aid in assembly.

4. Disconnect and remove stator (Figure 1, Item 4) from alternator assembly.
5. Remove two screws (Figure 1, Item 6) from capacitor (Figure 1, Item 7).
6. Remove capacitor (Figure 1, Item 7) from alternator assembly.
7. Remove diode trio (Figure 1, Item 8) from alternator assembly.
8. Remove two screws (Figure 1, Item 9) from rectifier bridge assembly (Figure 1, Item 12).
9. Remove nut (Figure 1, Item 10) from alternator assembly.
10. Remove relay terminal (Figure 1, Item 11) from rectifier bridge assembly (Figure 1, Item 12).
11. Remove rectifier bridge assembly (Figure 1, Item 12) from alternator assembly.

DISASSEMBLY - CONTINUED

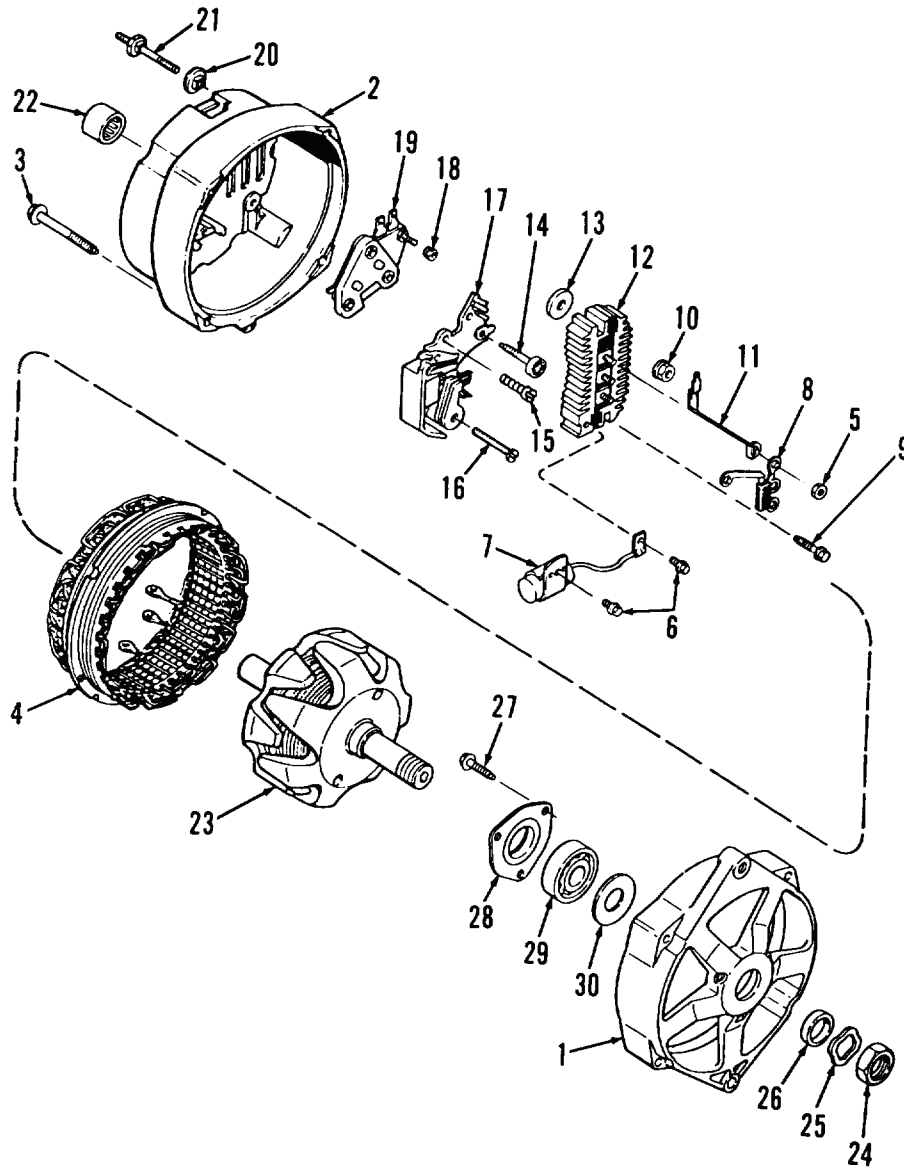

TA127134

Figure 1. Alternator Assembly.

**DISASSEMBLY - CONTINUED**

12. Remove terminal stud insulator (Figure 2, Item 13) from alternator assembly.
13. Remove two screws (Figure 2, Item 14) from brush holder (Figure 2, Item 17).
14. Remove screw (Figure 2, Item 15) from brush holder (Figure 2, Item 17).
15. Remove screw (Figure 2, Item 16) from brush holder (Figure 2, Item 17).
16. Remove brush holder (Figure 2, Item 17) from alternator assembly.
17. Remove nut (Figure 2, Item 18) from voltage regulator (Figure 2, Item 19).
18. Remove voltage regulator (Figure 2, Item 19) from slip ring end frame (Figure 2, Item 2).
19. Remove outer terminal stud insulator (Figure 2, Item 20) from alternator assembly.
20. Remove stud terminal (Figure 2, Item 21) from alternator assembly.
21. Position slip ring end frame (Figure 2, Item 2) on open jaws of vise, so jaws support area around bearings.

**NOTE**

Remove roller bearings only if worn, cracked, pitted, or damaged, or if grease supply is exhausted.

22. Use valve guide installer tool and press roller bearing (Figure 2, Item 22) out of end frame (Figure 2, Item 2). Discard bearing.
23. Use vise to hold rotor (Figure 2, Item 23) and remove from drive end frame (Figure 2, Item 1).

**CAUTION**

Do not overtighten vise. Overtightening may distort and damage rotor.

24. Remove shaft nut (Figure 2, Item 24) from shaft of rotor (Figure 2, Item 23).
25. Remove lockwasher (Figure 2, Item 25) from shaft of rotor (Figure 2, Item 23). Discard lockwasher.
26. Remove shaft collar (Figure 2, Item 26) from shaft of rotor (Figure 2, Item 23).
27. Remove drive end frame (Figure 2, Item 1) from rotor (Figure 2, Item 23).
28. Remove three screws (Figure 2, Item 27) from ball bearing retainer plate (Figure 2, Item 28).
29. Remove ball bearing retainer plate (Figure 2, Item 28) from alternator assembly.
30. Use front cover seal installer tool to back up bearing housing on drive end frame (Figure 2, Item 1).
31. Use valve guide installer tool and press ball bearing (Figure 2, Item 29) out of driver end frame (Figure 2, Item 1).
32. Remove grease slinger washer (Figure 2, Item 30) from driver end frame (Figure 2, Item 1). Discard grease slinger washer.

DISASSEMBLY - CONTINUED

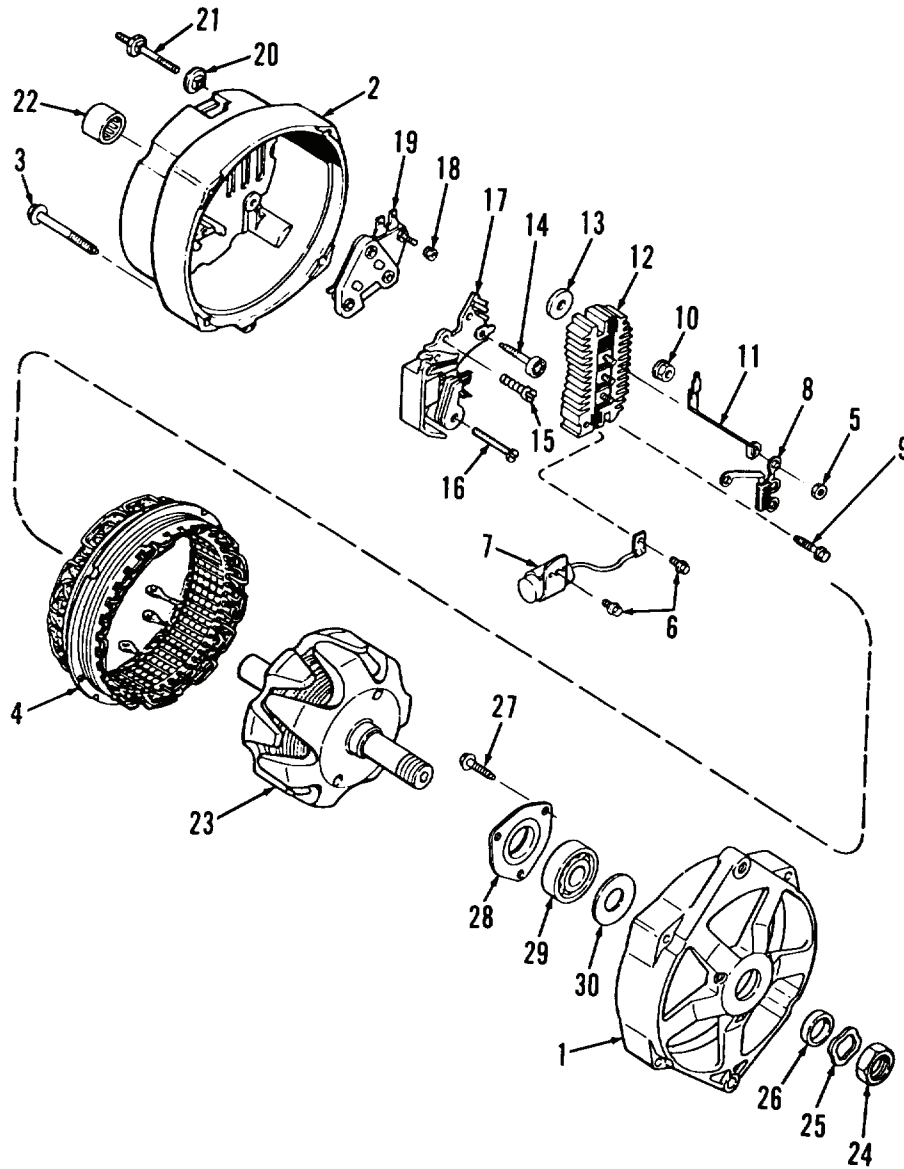

TA127134

Figure 2. Alternator Assembly.

END OF TASK

**CLEANING****CAUTION**

Do not clean stator or rotor with cleaning solvent.

1. Wipe stator (Figure 3, Item 4) and rotor (Figure 3, Item 23) with clean, soft, absorbent, lint-free rag.

**WARNING**

- Solvent cleaning compound MIL-PRF-680 Type III is an environmentally compliant and low toxic material. However, it may be irritating to the eyes and skin. Use protective gloves and goggles. Use in well-ventilated areas. Keep away from open flames and other sources of ignition. Failure to do so may result in injury or death to personnel.
  - Particles blown by compressed air are hazardous. DO NOT exceed 15 PSI (103 kPa) nozzle pressure when drying parts with compressed air. DO NOT direct compressed air against human skin. Make sure air stream is directed away from user and other personnel in the area. To prevent injury, user must wear protective goggles or face shield. Failure to follow this warning may result in injury to personnel.
2. Use clean, soft, absorbent, lint-free rag moistened with solvent cleaning compound to clean all other parts. Dry thoroughly with compressed air.

**END OF TASK****INSPECTION**

1. Inspect drive end frame (Figure 3, Item 1) and slip ring end frame (Figure 3, Item 2). Replace if cracked, worn, damaged, or distorted.
2. Inspect stator (Figure 3, Item 4). Replace if worn, damaged, discolored, unwound, or evidence of overheating.
3. Inspect bearings (Figure 3, Items 22 and 29). Replace if worn, cracked, pitted, or damaged.
4. Inspect ball bearing retainer plate (Figure 3, Item 28). Replace if retainer plate felt is hard or worn.
5. Inspect rotor (Figure 3, Item 23). Replace if worn, damaged, cracked, distorted, damaged threads, or slip rings damaged or scored.
6. Inspect all other parts. Replace if worn, cracked, damaged, or distorted.

INSPECTION - CONTINUED

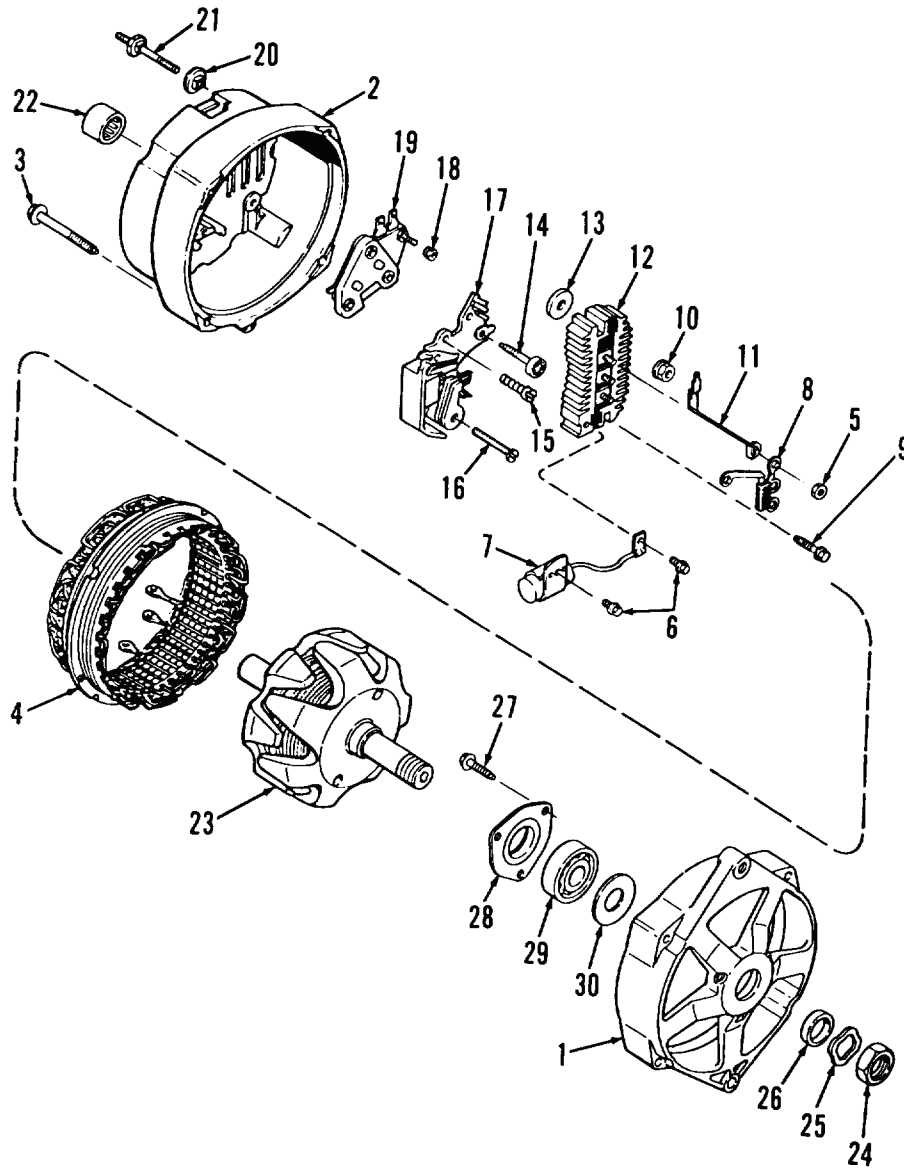

TA127134

Figure 3. Alternator Assembly.

END OF TASK

## TESTING

## CAUTION

Do not use 110V test lamp to test diode trio. Doing so could damage diode trio.

1. **Diode trio:** Set ohmmeter to lowest resistance range. Connect ohmmeter leads to single connector tab and one of three stator lead connectors as shown (Figure 4). Observe reading. Reverse ohmmeter leads and observe reading. Repeat procedure with each of two remaining stator lead connectors. Reading should be one low and one high reading for each test. If readings are either both high or low, replace diode trio.

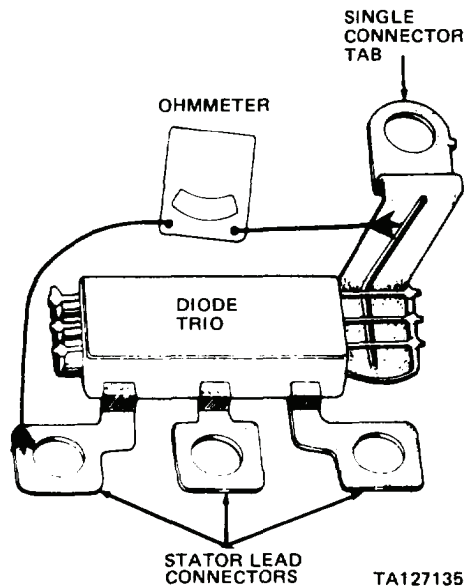
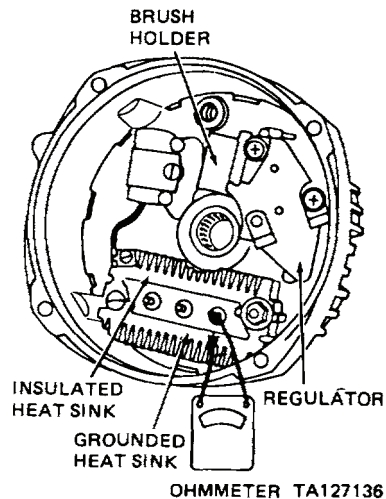

Figure 4. Diode Trio.

2. **Rectifier bridge assembly:** Use ohmmeter. Connect prod to grounded heat sink and base of one of three terminals as shown (Figure 5). Observe reading. Reverse prods. Observe reading. If readings are identical, replace bridge. Repeat procedure with remaining two terminals. Connect prods to insulated heat sink and one of three terminals. Observe reading. If readings are identical, replace rectifier bridge assembly. Repeat procedure with each of two remaining terminals.



TA127136

Figure 5. Rectifier Bridge Assembly.



**TESTING - CONTINUED**

3. **Stator:** Use ohmmeter. Connect test prods as shown (Figure 6). If meter reading is low when connected to any stator lead and frame, windings are grounded. If meter reading is high when connected between each pair of stator leads, windings are open. If stator winding is grounded or open or if evidence of short is observed, replace stator.

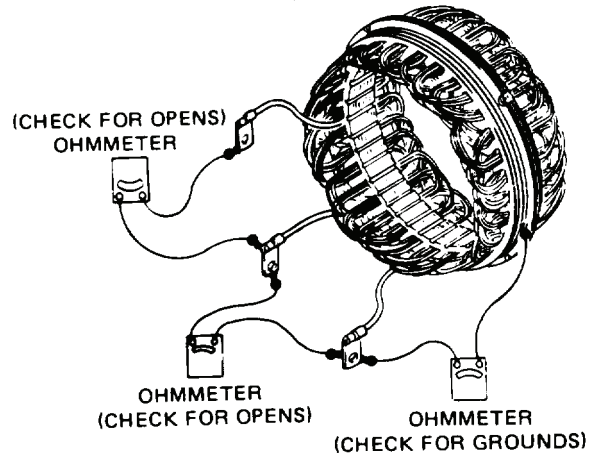

TA127504

**Figure 6. Stator.**

4. **Rotor:** Use 110V test lamp. Connect test lamp from rotor slip ring to rotor shaft as shown as shown (Figure 7). If lamp lights, field windings are grounded. Connect test lamp leads to each rotor slip ring. If lamp fails to light, field windings are open. Connect ammeter and battery to rotor as shown. If ammeter indicates more than 4.0 to 4.5 amperes, rotor field windings are shorted. If field windings are grounded, open, or have shorted, replace rotor.

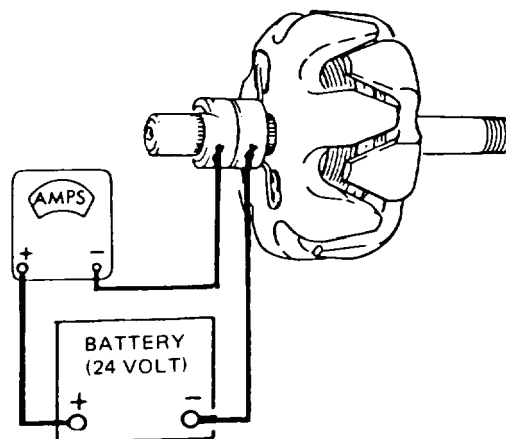

TA127137

**Figure 7. Rotor.****END OF TASK**

**ASSEMBLY**

1. Install new grease slinger washer (Figure 8, Item 30) on drive end frame (Figure 8, Item 1).
2. Use camshaft gear remover tool to back up new grease slinger washer (Figure 8, Item 30) inside of bearing area on end frame (Figure 8, Item 1).
3. Install ball bearing (Figure 8, Item 29). Press on closed end of ball bearing until flush with end frame housing.
4. Install ball bearing retainer plate (Figure 8, Item 28). Use valve guide installer tool until retainer seats against ball bearing (Figure 8, Item 29).
5. Install three screws (Figure 8, Item 27) on ball bearing retainer plate (Figure 8, Item 28) and tighten.

**CAUTION**

Do not overtighten vise. Overtightening may distort and damage rotor.

6. Mount rotor (Figure 8, Item 23) in vise.
7. Install drive end frame (Figure 8, Item 1) on rotor (Figure 8, Item 23).
8. Install shaft collar (Figure 8, Item 26), new lockwasher (Figure 8, Item 25), and shaft nut (Figure 8, Item 24). Tighten shaft nut hand-tight only.
9. Use camshaft gear remover tool on area surrounding bearing recess slip ring end frame (Figure 8, Item 2).
10. Install roller bearing (Figure 8, Item 22). Press on until roller bearing is flush with end frame housing.
11. Position outer terminal stud insulator (Figure 8, Item 20) on slip ring end frame (Figure 8, Item 2).
12. Install terminal stud (Figure 8, Item 21) on slip ring end frame (Figure 8, Item 2).
13. Position voltage regulator (Figure 8, Item 19) on slip ring end frame (Figure 8, Item 2) and install nut (Figure 8, Item 18). Tighten nut.
14. Position brush holder (Figure 8, Item 17) on voltage regulator (Figure 8, Item 19) and install four screws (Figure 8, Items 16, 15, and 14). Tighten screws.
15. Install inner terminal stud insulator (Figure 8, Item 13) on stud terminal (Figure 8, Item 21).
16. Position rectifier bridge assembly (Figure 8, Item 12) on alternator assembly.
17. Install relay terminal (Figure 8, Item 11) on rectifier bridge assembly (Figure 8, Item 12).
18. Install nut (Figure 8, Item 10) on terminal stud (Figure 8, Item 21) and tighten.
19. Install two screws (Figure 8, Item 9) on rectifier bridge assembly (Figure 8, Item 12) and tighten.
20. Install diode trio (Figure 8, Item 8) on rectifier bridge assembly (Figure 8, Item 12).
21. Position capacitor (Figure 8, Item 7) on rectifier bridge assembly (Figure 8, Item 12) and install two screws (Figure 8, Item 6). Tighten screws.
22. Install and connect stator (Figure 8, Item 4) on alternator assembly.

**CAUTION**

Take care to not damage stator.

23. Install three nuts (Figure 8, Item 5) on rectifier bridge assembly (Figure 8, Item 12) and tighten.
24. Position drive end frame (Figure 8, Item 1) on alternator assembly and align positioning marks on end frames (Figure 8, Items 1 and 2).

## ASSEMBLY - CONTINUED

## CAUTION

Use caution not to damage rotor and stator. Do not use hammer to install drive end frame in slip ring end frame. Hand push around entire circumference.

25. Install four thru bolts (Figure 8, Item 3) on alternator assembly and tighten alternately until end frames (Figure 8, Items 1 and 2) are securely fastened.

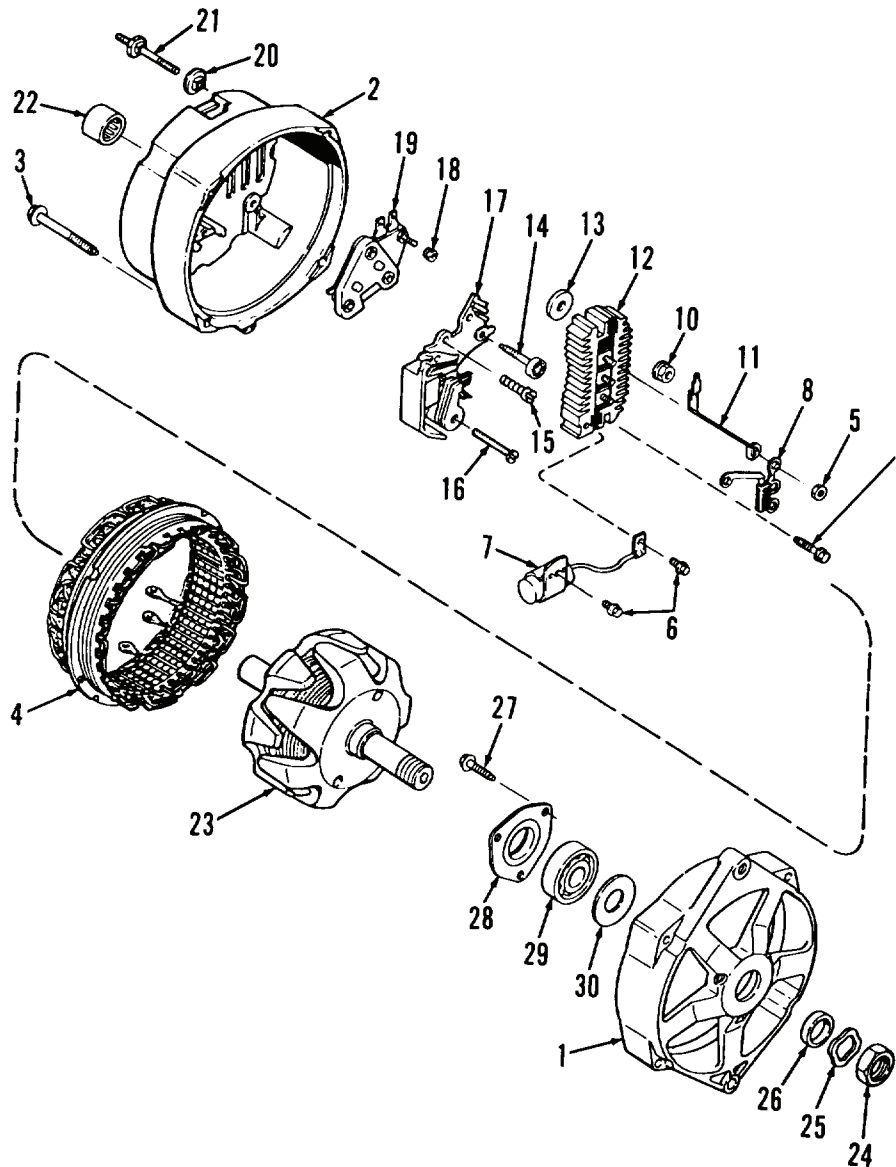

TA127134

Figure 8. Alternator Assembly.

END OF TASK

END OF WORK PACKAGE



---

## DIRECT SUPPORT MAINTENANCE INSTRUCTIONS

### STARTER AND SOLENOID REPAIR (MODEL 207)

Disassembly, Cleaning, Inspection, Testing, Assembly

---

#### INITIAL SETUP

##### Maintenance Level

Direct Support

##### Tools and Special Tools

Tool kit, general mechanic's (Item 15, WP 0309)

Shop equipment, common no. 1 (Item 2, WP 0309)

##### Materials/Parts

Cleaning compound, solvent (Item 10, WP 0310)

Lubricating oil, OE/HDO-10 (Item 20, WP 0310)

Lubriplate (Item 23, WP 0310)

##### Materials/Parts - Continued

Rag, wiping (Item 26, WP 0310)

Tape, electrical (Item 35, WP 0310)

Gasket

Lockwasher (7)

Oil seal

Washer (3)

##### Equipment Condition

Starter and solenoid removed (WP 0095)

---

---

**DISASSEMBLY**

1. Remove screw (Figure 1, Item 1) from connector (Figure 1, Item 2) and detach connector from solenoid (Figure 1, Item 24).
2. Remove two thru bolts (Figure 1, Item 3) from starter and solenoid assembly.
3. Remove end frame (Figure 1, Item 4) from field frame (Figure 1, Item 7).
4. Remove pipe plug (Figure 1, Item 5) and wick (Figure 1, Item 6) from end frame (Figure 1, Item 4).
5. Remove two screws (Figure 1, Item 8) and lockwashers (Figure 1, Item 9) from drive housing (Figure 1, Item 53). Discard lockwashers.
6. Remove armature (Figure 1, Item 10) from starter and solenoid assembly.
7. Remove and discard washer (Figure 1, Item 11) from armature (Figure 1, Item 10).
8. Remove and discard washer (Figure 1, Item 12) from drive assembly (Figure 1, Item 15).
9. Use a 1/2 in. pipe coupling, or an old pinion, to press stop collar (Figure 1, Item 13) toward armature to expose retaining ring (Figure 1, Item 14).
10. Use pliers to remove retaining ring (Figure 1, Item 14) from drive assembly (Figure 1, Item 15).
11. Remove stop collar (Figure 1, Item 13) from drive assembly (Figure 1, Item 15).
12. Remove drive assembly (Figure 1, Item 15) from armature shaft.
13. Remove washer (Figure 1, Item 16) from armature shaft. Discard washer.
14. Remove center bearing assembly (Figure 1, Item 17) from armature shaft.

DISASSEMBLY - CONTINUED

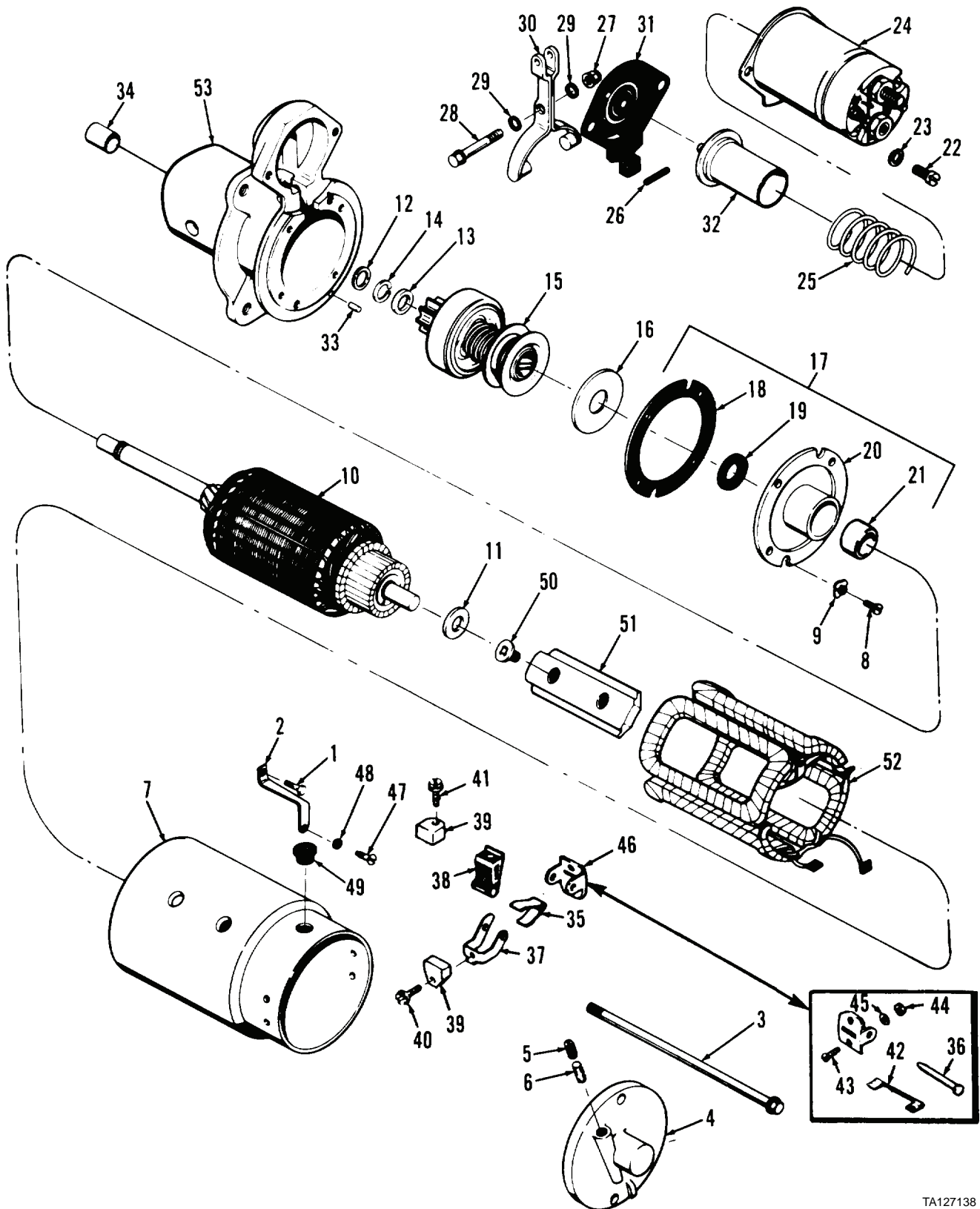

Figure 1. Starter and Solenoid.

TA127138

15. Remove and discard gasket (Figure 2, Item 18) at center bearing (Figure 2, Item 20).
16. Remove and discard oil seal (Figure 2, Item 19) at center bearing (Figure 2, Item 20).
17. Remove sleeve bearing (Figure 2, Item 21) from center bearing (Figure 2, Item 20).
18. Remove two screws (Figure 2, Item 22) and lockwashers (Figure 2, Item 23) from solenoid switch (Figure 2, Item 24). Discard lockwashers.
19. Remove solenoid switch (Figure 2, Item 24) from drive housing (Figure 2, Item 53).
20. Remove plunger spring (Figure 2, Item 25) from plunger (Figure 2, Item 32).
21. Remove spring pin (Figure 2, Item 26) from boot (Figure 2, Item 31).
22. Remove nut (Figure 2, Item 27) from screw (Figure 2, Item 28).
23. Remove screw (Figure 2, Item 28) and two seal washers (Figure 2, Item 29) from shift lever (Figure 2, Item 30).
24. Remove shift lever (Figure 2, Item 30) and boot (Figure 2, Item 31) from plunger (Figure 2, Item 32).
25. Remove pin (Figure 2, Item 33) from drive housing (Figure 2, Item 53).
26. Remove sleeve bearing (Figure 2, Item 34) from drive housing (Figure 2, Item 53).
27. Release two brush springs (Figure 2, Item 35).
28. Remove two brush support pins (Figure 2, Item 36) from two control assemblies (Figure 2, Item 46).
29. Remove two brush holders (Figure 2, Items 37 and 38), four screws (Figure 2, Items 40 and 41), two brushes (Figure 2, Item 39), and two brush springs (Figure 2, Item 35) from starter assembly as a unit.
30. Disconnect and remove two ground brush leads (Figure 2, Item 42) from two control assemblies (Figure 2, Item 46).
31. Disassemble four screws (Figure 2, Items 40 and 41), two brush holders (Figure 2, Items 37 and 38), brush (Figure 2, Item 39), and brush springs (Figure 2, Item 35).
32. Remove four screws (Figure 2, Item 43) from two control assemblies (Figure 2, Item 46).
33. Remove four nuts (Figure 2, Item 44) from two control assemblies (Figure 2, Item 46).
34. Remove and discard four lockwashers (Figure 2, Item 45) from two control assemblies (Figure 2, Item 46).
35. Remove two control assemblies (Figure 2, Item 46).
36. Remove screw (Figure 2, Item 47) and lockwasher (Figure 2, Item 48) from connector (Figure 2, Item 2) and remove connector from assembly. Discard lockwasher.
37. Remove grommet (Figure 2, Item 49) from field frame (Figure 2, Item 7).
38. Remove eight screws (Figure 2, Item 50) from four pole shoes (Figure 2, Item 51).
39. Remove four pole shoes (Figure 2, Item 51) from field coil assembly (Figure 2, Item 52).
40. Remove and release field coil assembly (Figure 2, Item 52) from assembly.



DISASSEMBLY - CONTINUED

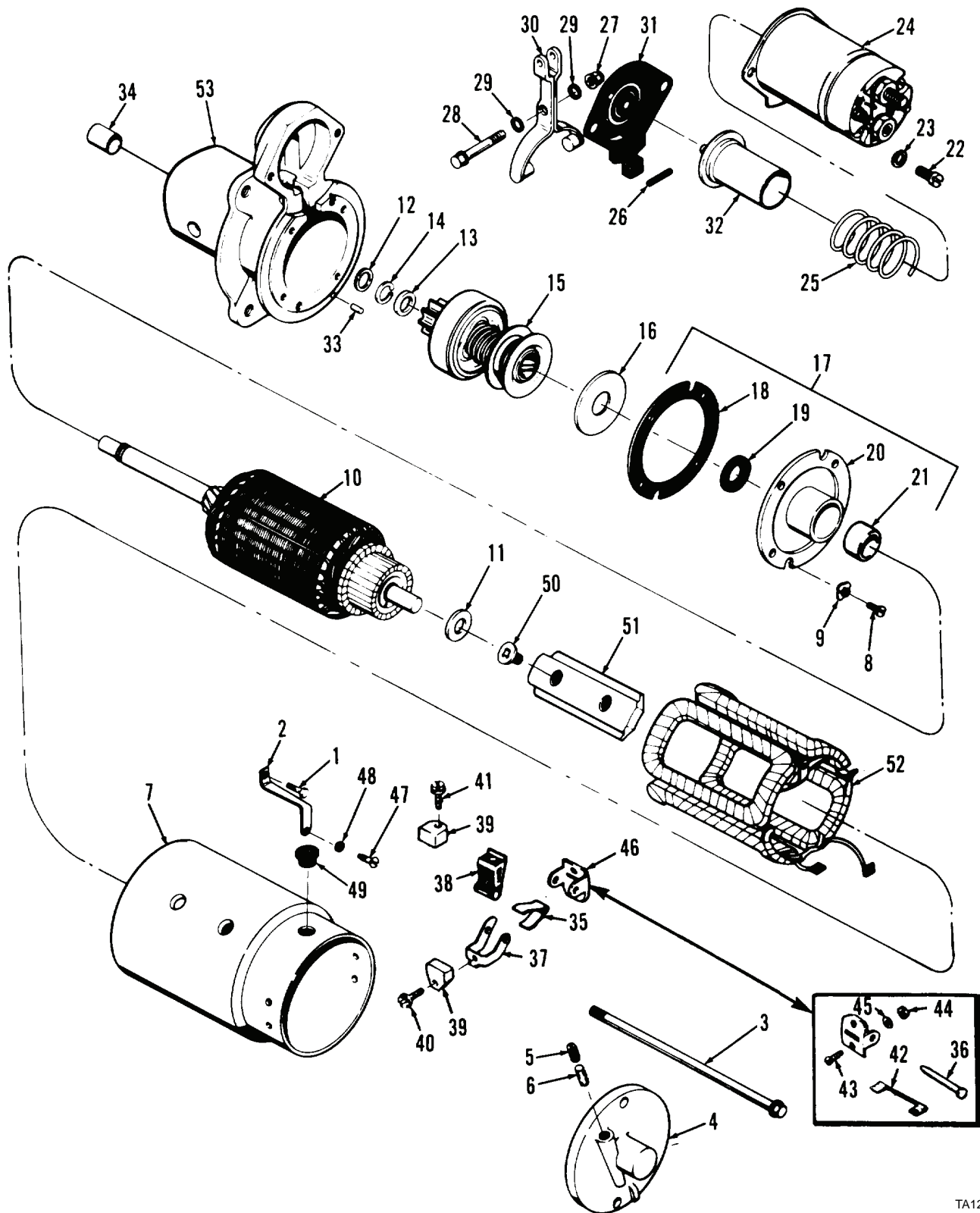

Figure 2. Starter and Solenoid.

TA127138

END OF TASK

## CLEANING

1. Wipe armature (Figure 3, Item 10), drive assembly (Figure 3, Item 15), solenoid switch (Figure 3, Item 24), brushes (Figure 3, Item 39), grommet (Figure 3, Item 49), and coil assembly (Figure 3, Item 52) with clean, dry, lint-free rag only. Do not use solvent cleaning compound.



WARNING



- Solvent cleaning compound MIL-PRF-680 Type III is an environmentally compliant and low toxic material. However, it may be irritating to the eyes and skin. Use protective gloves and goggles. Use in well-ventilated areas. Keep away from open flames and other sources of ignition. Failure to do so may result in injury or death to personnel.
  - Particles blown by compressed air are hazardous. DO NOT exceed 15 PSI (103 kPa) nozzle pressure when drying parts with compressed air. DO NOT direct compressed air against human skin. Make sure air stream is directed away from user and other personnel in the area. To prevent injury, user must wear protective goggles or face shield. Failure to follow this warning may result in injury to personnel.
2. Use clean rag moistened with solvent cleaning compound to clean all other parts. Dry thoroughly with compressed air.

## END OF TASK

## INSPECTION

1. Inspect brushes (Figure 3, Item 39). Replace if cracked, crazed, distorted, or if brush wear exceeds one-half of new brush length.
2. Inspect brush holders (Figure 3, Items 37 and 38). Replace if cracked, worn, or distorted, or if brush does not move freely in holder.
3. Inspect brush springs (Figure 3, Item 35). Inspect for wear, cracks, distortion, or discoloration. Check brush spring tension to ensure brushes are held firmly. If tension is weak or if any other condition is observed, replace spring.
4. Inspect sleeve bearings (Figure 3, Items 21 and 34). Replace if worn, cracked, pitted, or burred.
5. Inspect drive assembly (Figure 3, Item 15). Replace if worn, damaged, distorted, or pinion teeth cracked, chipped, worn, or damaged, or pinion does not turn freely in over-running direction.
6. Inspect armature (Figure 3, Item 10). Replace if worn, cracked, damaged, or distorted or commutator rough or out-of-round.
7. Inspect solenoid switch (Figure 3, Item 24). Replace if cracked, worn, damaged, or distorted.
8. Inspect all other parts. Replace if worn, cracked, damaged, or distorted.

INSPECTION - CONTINUED

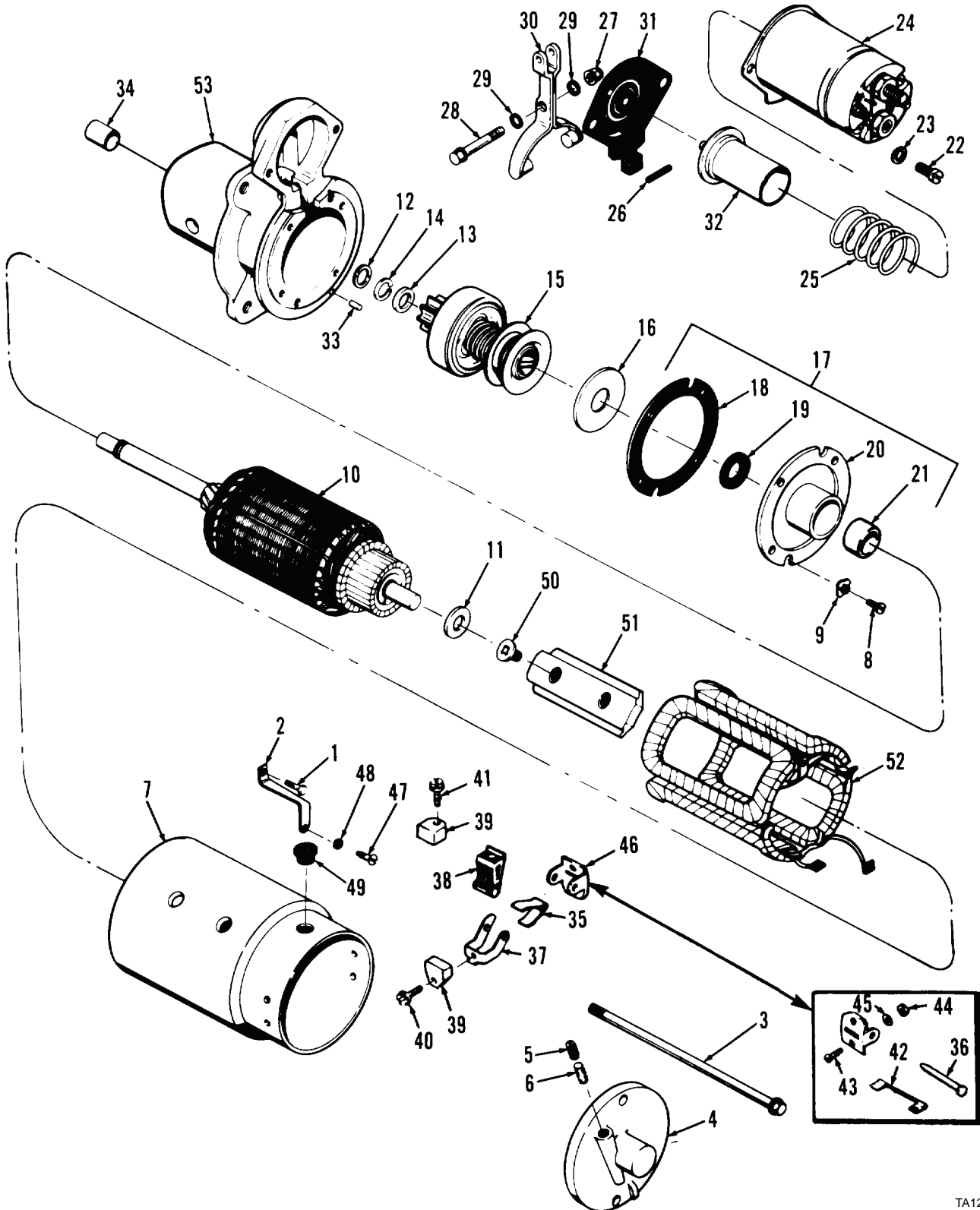

Figure 3. Starter and Solenoid.

TA127138

END OF TASK

**TESTING**

1. Test armature (Figure 4) for grounded winding:

Place armature in growler and turn power on. Touch one test probe to armature core, and second probe to commutator, as shown (Figure 4). If test lamp glows, armature winding or commutator is grounded.

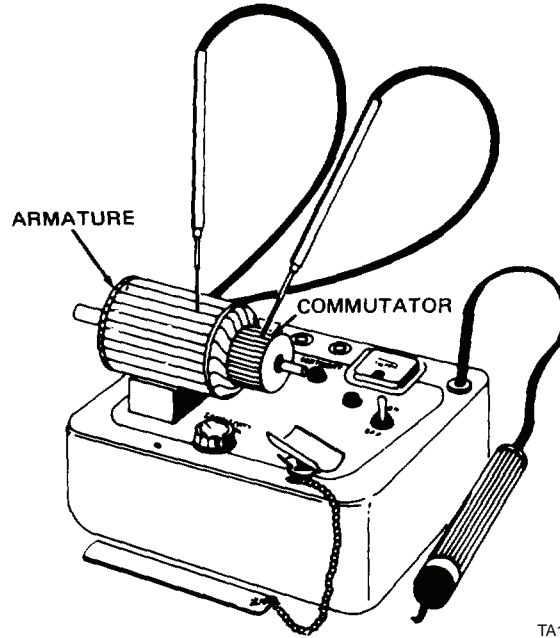

**Figure 4. Testing Armature for Grounded Winding.**

2. Test for shorted winding:

- a. Place armature in growler. Turn on power. Use steel blade provided with tester. Hold blade parallel with and touching armature core segment, as shown (Figure 5).

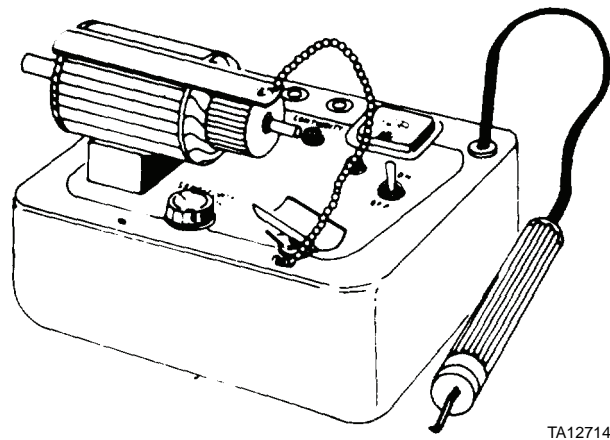

**Figure 5. Testing Armature for Shorted Winding.**

**TESTING - CONTINUED**

- b. Rotate armature slowly one or more revolutions. If armature is shorted, steel blade will vibrate. Turn power off.
- c. Position armature in growler, as shown (Figure 6). Turn power on.

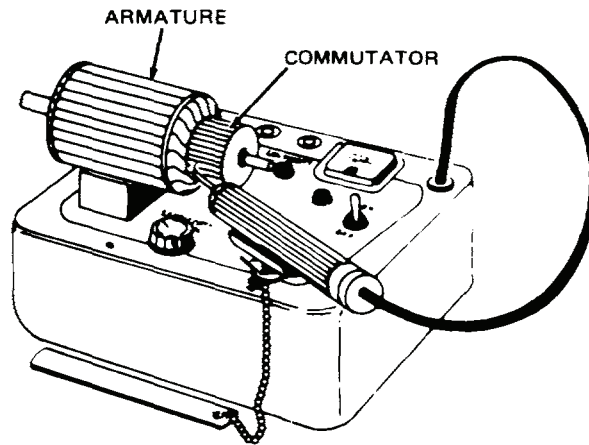

TA127141

**Figure 6. Testing Armature Commutator Bars.****3. Test commutator bars:**

Follow directions supplied with growler and test commutator bars for abnormal readings. Abnormal readings will indicate a short, open, or poor connection. If testing indicates commutator is grounded, armature is shorted or commutator readings indicate a short, or an open or poor connection, replace armature.

**4. Test field coil assembly (Figure 3, item 52):**

Disconnect field coil ground connection. Use test lamp. Connect one test probe of test lamp to connector and second probe to frame. If test lamp lights, field coils are grounded. If coils are grounded, remove and replace coils. Touch test probes to each end of field coil windings. If test lamp does not light, field coils are open. If coils are open, replace coil assembly.

**END OF TASK**

**ASSEMBLY**

1. Assemble and position field coil assembly (Figure 7, Item 52).
2. Position four pole shoes (Figure 7, Item 51) on field coil assembly (Figure 7, Item 52).
3. Install eight screws (Figure 7, Item 50) on four pole shoes (Figure 7, Item 51).
4. Install grommet (Figure 7, Item 49) on field frame (Figure 7, Item 7).
5. Position connector (Figure 7, Item 2) on field frame (Figure 7, Item 7) and install new lockwasher (Figure 7, Item 48) and screw (Figure 7, Item 47). Tighten screw.

**NOTE**

Always replace brushes and springs as a set.

6. Install two brushes (Figure 7, Item 39) on brush holders (Figure 7, Items 37 and 38).
7. Install four new lockwashers (Figure 7, Item 45) and screws (Figure 7, Item 43) on brush holders (Figure 7, Items 37 and 38).
8. Position two control assemblies (Figure 7, Item 46) in field frame (Figure 7, Item 7).
9. Install four new lockwashers (Figure 7, Item 45), screws (Figure 7, Item 43), nuts (Figure 7, Item 44), and two brush support pins (Figure 7, Item 36) on two control assemblies (Figure 7, Item 46).
10. Position two brush holder assemblies (Figure 7, Items 37 and 38) in control assembly (Figure 7, Item 46). Push holders and spring to bottom of control assembly and rotate spring to engage slot in assembly.
11. Connect two ground brush leads (Figure 7, Item 42) to two control assemblies (Figure 7, Item 46).
12. Install sleeve bearing (Figure 7, Item 21) on center bearing (Figure 7, Item 20).
13. Install new oil seal (Figure 7, Item 19) and new gasket (Figure 7, Item 18) on center bearing (Figure 7, Item 20).
14. Install center bearing assembly (Figure 7, Item 17) and new washer (Figure 7, Item 16) on drive assembly (Figure 7, Item 15).

**NOTE**

Apply light coat of lubricant to drive end of armature shaft. Slide drive assembly onto shaft with pinion away from armature.

15. Lubricate and position and armature (Figure 7, Item 10) shaft and drive assembly (Figure 7, Item 15) together.
16. Position stop collar (Figure 7, Item 13) with cupped surface of collar facing away from armature.
17. Stand armature (Figure 7, Item 10) on a wood block with commutator down.
18. Install retaining ring (Figure 7, Item 14). Tap into place with small block of wood and a hammer.
19. Install stop collar (Figure 7, Item 13). Force stop collar over retaining ring. Place washer over retaining ring. Squeeze collar and washer together using pliers. Remove and discard washer.
20. Install new washer (Figure 7, Item 12) on drive assembly (Figure 7, Item 15).
21. Install new washer (Figure 7, Item 11) on armature (Figure 7, Item 10) shaft.
22. Install sleeve bearing (Figure 7, Item 34) on drive housing.
23. Install pin (Figure 7, Item 33) on drive housing (Figure 7, Item 53).
24. Install armature (Figure 7, Item 10) and drive assembly (Figure 7, Item 15) on drive housing (Figure 7, Item 53).
25. Position two new lockwashers (Figure 7, Item 9) and install two screws (Figure 7, Item 8) on center bearing assembly (Figure 7, Item 17).
26. Install shift lever (Figure 7, Item 30) and engage with drive assembly.
27. Position two new seal washers (Figure 7, Item 29) and install screw (Figure 7, Item 28) and nut (Figure 7, Item 27).
28. Position boot (Figure 7, Item 31) and apply sealer to drive housing frame.
29. Position plunger (Figure 7, Item 32) on shift lever (Figure 7, Item 30).

ASSEMBLY - CONTINUED

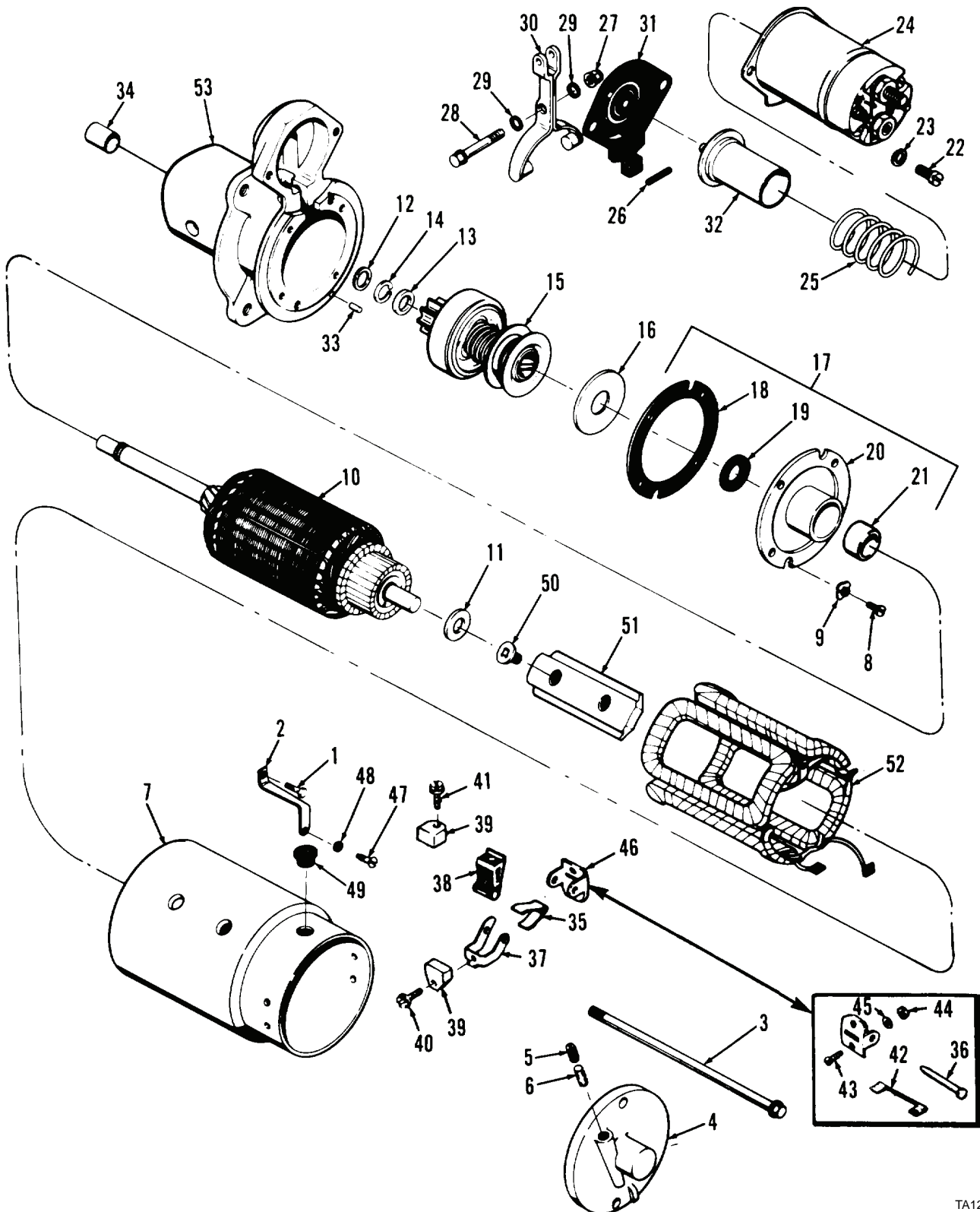

Figure 7. Starter and Solenoid.

TA127138

**ASSEMBLY - CONTINUED**

30. Press on plunger (Figure 7, Item 32) and shift lever (Figure 7, Item 30) and install spring pin (Figure 7, Item 26).
31. Position plunger spring (Figure 7, Item 25) over plunger (Figure 7, Item 32).
32. Position solenoid switch (Figure 7, Item 24) against drive housing (Figure 7, Item 53) and install two new lockwashers (Figure 7, Item 23) and screws (Figure 7, Item 22) on solenoid. Tighten screws.
33. Position field frame (Figure 7, Item 7) over armature.

**CAUTION**

Take care not to damage brushes when positioning frame over armature.

34. Apply sealant to field frame (Figure 7, Item 7) and solenoid switch (Figure 7, Item 24).
35. Saturate with lubricating oil and install wick (Figure 7, Item 6) on end frame (Figure 7, Item 4).
36. Install pipe plug (Figure 7, Item 5) in end frame (Figure 7, Item 4).
37. Apply light coat of lubricant to bushing of end frame (Figure 7, Item 4), then slide on armature shaft and push against field frame (Figure 7, Item 7).
38. Install two through bolts (Figure 7, Item 3) on alternator assembly and tighten.
39. Wrap field coil connector (Figure 7, Item 2) with electrical tape.
40. Connect starter and solenoid to test circuit as shown (Figure 8).

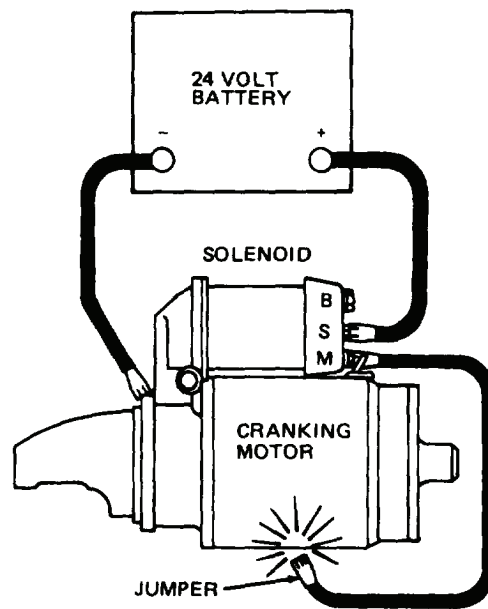

TA127142

**Figure 8. Testing Starter and Solenoid.**



**ASSEMBLY - CONTINUED****CAUTION**

Check position clearance quickly to avoid overheating and damage to solenoid windings.

41. Momentarily connect jumper lead from solenoid M terminal to starter case (to shift pinion into cranking position).

**NOTE**

Pinion clearance must measure between 0.010 and 0.140 in. (0.25 and 3.56 mm) to prevent buttons on the shift lever yoke from rubbing on the clutch collar during cranking. If clearance does not fall within limits, recheck for proper assembly and replace all worn parts.

42. Push clutch of drive assembly (Figure 7, Item 15) pinion back as far as possible toward armature, and check clearance as shown (Figure 9).

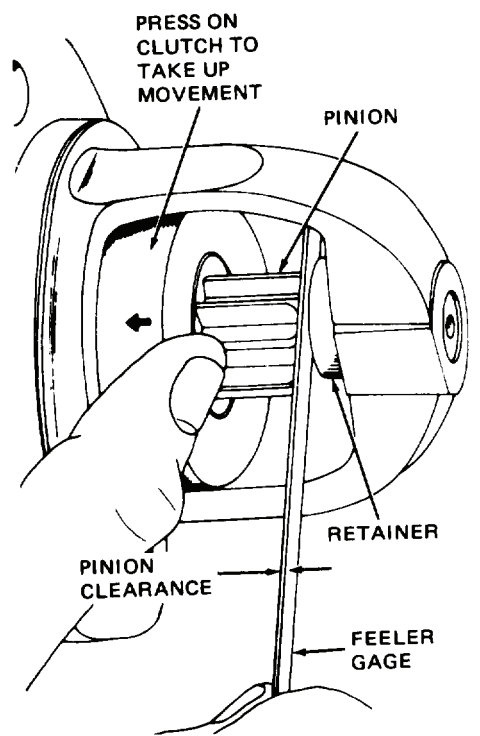

**Figure 9. Checking Pinion Clearance.**

**ASSEMBLY - CONTINUED**

- 43. Disconnect starter and solenoid from pinion clearance test set-up.
- 44. Remove tape and position field coil connector (Figure 10, Item 2) on M terminal of solenoid switch (Figure 10, Item 24).
- 45. Install screw (Figure 10, Item 1) on field coil connector (Figure 10, Item 2) and tighten.

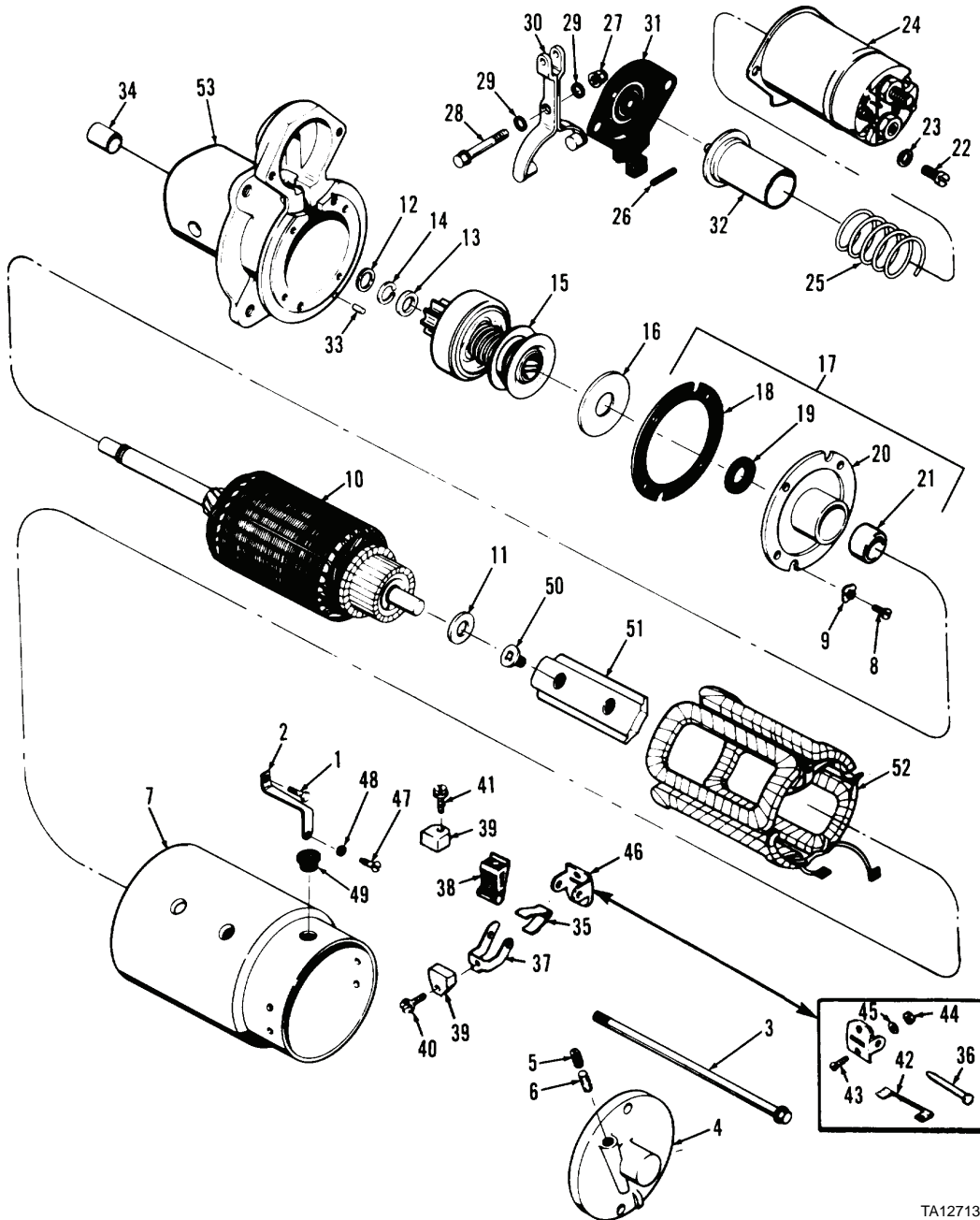

TA127138

**Figure 10. Starter and Solenoid.**

**END OF TASK**

**END OF WORK PACKAGE**

---

## DIRECT SUPPORT MAINTENANCE INSTRUCTIONS

### INSTRUMENT PANEL REPLACEMENT

#### Removal, Cleaning, Inspection, Installation

---

#### INITIAL SETUP

**Maintenance Level**

Direct Support

**Tools and Special Tools**

Tool kit, general mechanic's (Item 15, WP 0309)  
Shop equipment, common no. 1 (Item 2, WP 0309)  
Sling and hoist

**Materials/Parts**

Cleaning compound, solvent (Item 10, WP 0310)  
Rag, wiping (Item 26, WP 0310)  
Lockwasher (4)

**Personnel Required**

Two

**Equipment Condition**

Flood light switches, cables, retaining brackets and circuit breakers, start switch, vehicle lights switch, ignition switch and circuit breaker, lock-out relay, and warning lights and diodes removed (WP 0104, WP 0105, and WP 0106)

**Equipment Condition - Continued**

Gages removed (WP 0203)  
Two front floodlights mounted on fender support brackets removed (WP 0111 and WP 0112)  
Horn removed (WP 0127 and WP 0128)  
Transmission linkage and leaves removed (WP 0148)  
Rollover protective structure (ROPS) removed (WP 0174)  
Front fenders retaining hardware removed (WP 0178)  
Hydraulic control levers and linkages removed (WP 0191)  
Steering wheel and column removed (WP 0257)  
Steering gear removed (WP 0258)  
Control valve removed (WP 0262)

---

**REMOVAL**

1. Remove four nuts (Figure 1, Item 1), lockwashers (Figure 1, Item 2), and washers (Figure 1, Item 3). Discard lockwashers.
2. Remove four capscrews (Figure 1, Item 4) and large washers (if equipped).
3. Use sling and hoist to remove instrument panel (Figure 1, Item 5).

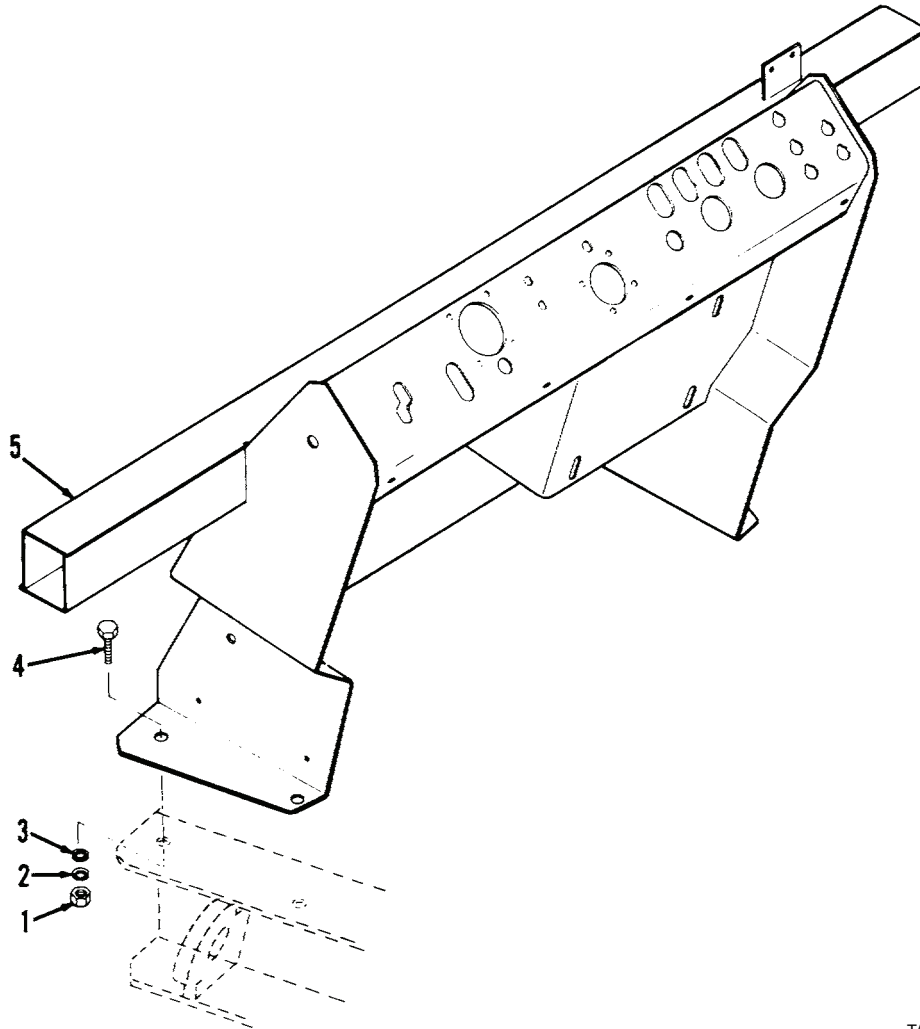
**Figure 1. Instrument Panel.**

TA127146

**END OF TASK**

**CLEANING****WARNING**

- Solvent cleaning compound MIL-PRF-680 Type III is an environmentally compliant and low toxic material. However, it may be irritating to the eyes and skin. Use protective gloves and goggles. Use in well-ventilated areas. Keep away from open flames and other sources of ignition. Failure to do so may result in injury or death to personnel.
- Particles blown by compressed air are hazardous. DO NOT exceed 15 PSI (103 kPa) nozzle pressure when drying parts with compressed air. DO NOT direct compressed air against human skin. Make sure air stream is directed away from user and other personnel in the area. To prevent injury, user must wear protective goggles or face shield. Failure to follow this warning may result in injury to personnel.

Use solvent cleaning compound to clean all parts. Dry thoroughly with compressed air.

**END OF TASK****INSPECTION**

1. Inspect nuts (Figure 1, Item 1), washers (Figure 1, Item 3), and capscrews (Figure 1, Item 4). Replace if worn, or if threads damaged.
2. Inspect instrument panel (Figure 1, Item 5). Repair broken welds or cracks by welding. Replace if severely cracked or damaged.

**END OF TASK****INSTALLATION**

1. Use sling and hoist to position instrument panel (Figure 1, Item 5) in operator's compartment, with frame and instrument panel mounting holes aligned.
2. Install four large washers (if equipped), capscrews (Figure 1, Item 4), washers (Figure 1, Item 3), new lockwashers (Figure 1, Item 2), and nuts (Figure 1, Item 1). Tighten nuts.

**END OF TASK****END OF WORK PACKAGE**



---

## DIRECT SUPPORT MAINTENANCE INSTRUCTIONS

### FRONT WIRING HARNESS REPLACEMENT (MODEL 207)

#### Removal, Installation

---

#### INITIAL SETUP

**Maintenance Level**

Direct Support

**Tools and Special Tools**

Tool kit, general mechanic's (Item 15, WP 0309)

Shop equipment, common no. 1 (Item 2, WP 0309)

**Materials/Parts**

Strap, tiedown (Item 32, WP 0310)

Tag, marker (Item 33, WP 0310)

**Materials/Parts - Continued**

Lockwasher (10)

**Equipment Condition**

Engine OFF

Battery ground cable disconnected (WP 0133)

Front wiring harness connector disconnected (WP 0135)

Noise baffle mat rod and mat pulled up and over instrument panel for access to bottom of instrument panel (WP 0187)

---

---

**REMOVAL****NOTE**

Tag all electrical leads before disconnecting.

1. Disconnect all harness connectors.
2. Cut and discard four tiedown straps from harness and hydraulic return hose at rear of transmission.
3. Remove connector nut (Figure 1, Item 20) and washer (Figure 1, Item 21) from harness connector and bracket.
4. Cut and discard two tiedown straps (Figure 1, Item 2) from harness to stop light switch and brake tube.
5. Remove harness loops at 6 and 10 ampere circuit breakers, bottom of instrument panel.
6. Cut and discard two tiedown straps (Figure 1, Item 3) from clamps (Figure 1, Item 7) and instrument panel.
7. Remove instrument panel rear and right-hand side panel.
8. Remove three nuts (Figure 1, Item 4), lockwashers (Figure 1, Item 5), and capscrews (Figure 1, Item 6) from clamps (Figure 1, Item 7) and instrument panel. Discard lockwashers.
9. Spread and remove clamps (Figure 1, Item 7) from harness.
10. Remove nut (Figure 1, Item 8), lockwasher (Figure 1, Item 9), and capscrew (Figure 1, Item 10) from clamp (Figure 1, Item 11) and end panel. Discard lockwasher.
11. Remove three nuts (Figure 1, Item 16), lockwashers (Figure 1, Item 13), and capscrews (Figure 1, Item 14) from clamps (Figure 1, Item 15) and instrument panel. Discard lockwashers.
12. Remove three nuts (Figure 1, Item 16), lockwashers (Figure 1, Item 13), and capscrews (Figure 1, Item 18) from clamps (Figure 1, Item 19) and side panel. Discard lockwashers.
13. Remove front wiring harness from vehicle.
14. Disconnect warning lights diodes from harness.

**END OF TASK****INSTALLATION**

1. Position front wiring harness on vehicle.
2. Position clamps (Figure 1, Items 7, 11, 15, and 19) over harness and against instrument panel mounting holes.
3. Install capscrews (Figure 1, Items 6, 10, 14, and 18), new lockwashers (Figure 1, Items 5, 9, 13, and 17) and nuts (Figure 1, Items 4, 8, 12, and 16). Tighten nuts.
4. Install new tiedown straps (Figure 1, Items 1, 2, and 3) on harness, hydraulic return hose, and brake tube.
5. Connect all harness leads to electrical components.
6. Connect harness connectors to warning lights diodes
7. Check all electrical systems for correct operation.



INSTALLATION - CONTINUED

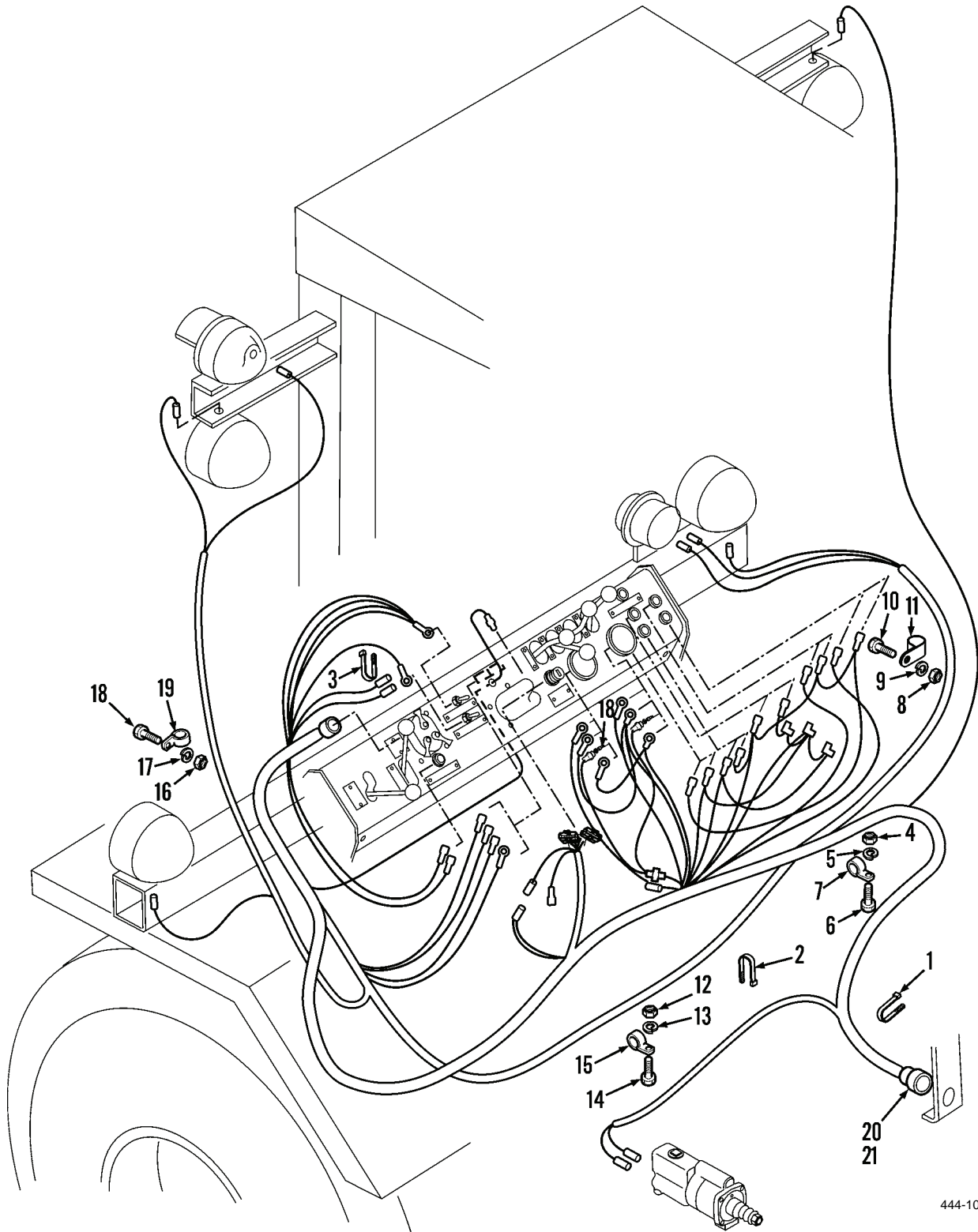

444-1096

Figure 1. Front Wiring Harness.

END OF TASK  
END OF WORK PACKAGE



---

## DIRECT SUPPORT MAINTENANCE INSTRUCTIONS

### FRONT WIRING HARNESS REPLACEMENT (MODEL 4-390)

#### Removal, Installation

---

#### INITIAL SETUP

##### Maintenance Level

Direct Support

##### Tools and Special Tools

Tool kit, general mechanic's (Item 15, WP 0309)

Shop equipment, common no. 1 (Item 2, WP 0309)

##### Materials/Parts

Strap, tiedown (Item 32, WP 0310)

Tag, marker (Item 33, WP 0310)

Front wiring harness

Lockwasher (10)

##### References

WP 0108

##### Equipment Condition

Engine OFF

Battery ground cable disconnected (WP 0134)

Front wiring harness connector disconnected (WP 0136)

Noise baffle mat rod removed and mat pulled up and over instrument panel for access to bottom of instrument panel (WP 0187)

---

#### NOTE

- Remove wiring harness clamps and cut tiedown straps as necessary. Discard tiedown straps.
- Tag all electrical leads before disconnecting.

---

**REMOVAL**

1. Disconnect all harness connectors from instrument panel bottom, stop light switch, and ROPS posts.
2. Cut and discard four tiedown straps (Figure 1, Item 1) from harness and hydraulic return hose.
3. Remove connector nut (Figure 1, Item 20) and washer (Figure 1, Item 21) from harness connector and bracket.
4. Cut and discard two tiedown straps (Figure 1, Item 2) from harness to stop light switch and brake tube under floor.
5. Cut and discard two tiedown straps (Figure 1, Item 3) from harness loops at 6 and 10 ampere circuit breakers, on bottom of instrument panel.
6. Cut and discard two tiedown straps (Figure 1, Item 3) from loops in harness wire.
7. Remove three nuts (Figure 1, Item 4), lockwashers (Figure 1, Item 5), and capscrews (Figure 1, Item 6) from clamps (Figure 1, Item 7) and instrument panel. Discard lockwashers.
8. Remove three clamps (Figure 1, Item 7) from harness.
9. Remove nut (Figure 1, Item 8), lockwasher (Figure 1, Item 9), and capscrew (Figure 1, Item 10) from clamp (Figure 1, Item 11) and end panel. Discard lockwasher.
10. Remove clamp (Figure 1, Item 11) from harness wire.
11. Remove three nuts (Figure 1, Item 12), lockwashers (Figure 1, Item 13), and capscrews (Figure 1, Item 14) from clamps (Figure 1, Item 15) and instrument panel. Discard lockwashers.
12. Remove three nuts (Figure 1, Item 16), lockwashers (Figure 1, Item 17), and capscrews (Figure 1, Item 18) from clamps (Figure 1, Item 19) and side panel. Discard lockwashers.
13. Remove front wiring harness from vehicle.
14. Remove warning light diodes from harness (WP 0108).

**END OF TASK****INSTALLATION**

1. Position front wiring harness on vehicle.
2. Position clamps (Figure 1, Items 7, 11, 15, and 19) over harness and against instrument panel mounting holes.
3. Install capscrews (Figure 1, Items 6, 10, 14, and 18), new lockwashers (Figure 1, Items 5, 9, 13, and 17), and nuts (Figure 1, Items 4, 8, 12, and 16). Tighten nuts.
4. Install new tiedown straps (Figure 1, Items 1, 2, and 3) on harness, hydraulic return hose, and brake tube.
5. Connect all harness leads to electrical components.
6. Connect harness connectors to warning light diodes (WP 0108).
7. Check all electrical systems for proper operation.

INSTALLATION - CONTINUED

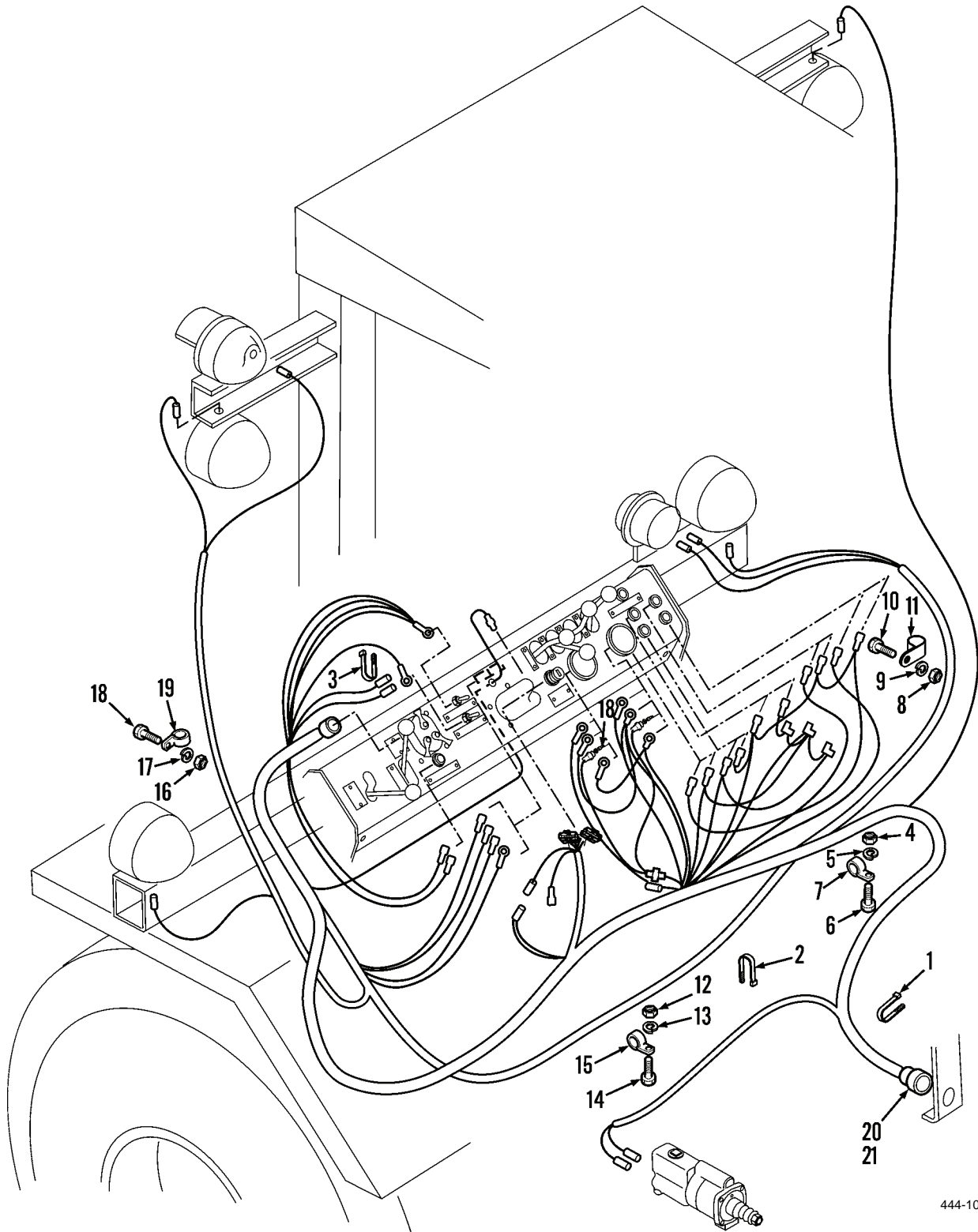

444-1096

Figure 1. Front Wiring Harness.

END OF TASK  
END OF WORK PACKAGE



---

## DIRECT SUPPORT MAINTENANCE INSTRUCTIONS

### REAR WIRING HARNESS REPLACEMENT (MODEL 207)

#### Removal, Installation

---

#### INITIAL SETUP

**Maintenance Level**

Direct Support

**Tools and Special Tools**

Tool kit, general mechanic's (Item 15, WP 0309)

Shop equipment, common no. 1 (Item 2, WP 0309)

**Materials/Parts**

Strap, tiedown (Item 32, WP 0310)

Tag, marker (Item 33, WP 0310)

**Materials/Parts - Continued**

Lockwasher (8)

**Equipment Condition**

Engine OFF

Battery ground cable disconnected (WP 0133)

Front wiring harness connector disconnected (WP 0135)

Radiator grille opened (WP 0177)

Left and right side panels removed (WP 0179)

---

**REMOVAL****NOTE**

Tag all electrical leads before disconnecting.

1. Disconnect all harness connectors and leads.
2. Cut and discard tiedown strap (Figure 1, Item 1) from harness and engine dipstick tube.
3. Cut and discard tiedown strap (Figure 1, Item 2) from harness and transmission cooler hose.
4. Remove accelerator cable nut (Figure 1, Item 3), lockwasher (Figure 1, Item 4), and capscrew (Figure 1, Item 5) from clamp (Figure 1, Item 6). Discard lockwasher.
5. Remove two nuts (Figure 1, Item 7), lockwashers (Figure 1, Item 8), bolts (Figure 1, Item 9), and washers (Figure 1, Item 10) from clamps (Figure 1, Item 11) and hydraulic tank. Discard lockwashers.
6. Remove two clamps (Figure 1, Item 11) from harness.
7. Remove nut (Figure 1, Item 14), lockwasher (Figure 1, Item 15), capscrew (Figure 1, Item 16), and ground cable (Figure 1, Item 17) from clamp (Figure 1, Item 18). Discard lockwasher.
8. Remove clamp (Figure 1, Item 18) from harness.
9. Remove engine timing gear cover bolt (Figure 1, Item 19) from clamp (Figure 1, Item 20) and timing gear cover.
10. Remove clamp (Figure 1, Item 20) from harness.
11. Remove nut (Figure 1, Item 21), lockwasher (Figure 1, Item 22), and capscrew (Figure 1, Item 23) from clamp (Figure 1, Item 24) and chassis side plate. Discard lockwasher.
12. Remove clamp (Figure 1, Item 24) from harness and battery cables.
13. Remove bolt (Figure 1, Item 25) and lockwasher (Figure 1, Item 26) from clamp (Figure 1, Item 27) and transmission cooler. Discard lockwasher.
14. Remove clamp (Figure 1, Item 27) from harness.
15. Remove two nuts (Figure 1, Item 28), lockwashers (Figure 1, Item 29), and capscrew (Figure 1, Item 30) from clamps (Figure 1, Item 31) and radiator baffle. Discard lockwashers.
16. Remove two clamps (Figure 1, Item 31) from harness.
17. Disconnect alternator warning light diode from rear wiring harness.
18. Remove rear wiring harness from vehicle.

**END OF TASK****INSTALLATION**

1. Position rear warning harness on vehicle.
2. Position harness clamps (Figure 1, Items 6, 11, 18, 24, 27, and 31) over harness and against mounting holes.

**NOTE**

Make sure all lockwashers are new.

3. Install clamp mounting hardware (Figure 1, Items 3, 4, 5, 7, 8, 9, 10, 14, 15, 16, 19, 21, 22, 23, 25, 26, 28, 29, and 30) and tighten.
4. Install new tiedown straps (Figure 1, Items 1 and 2) around harness, engine dipstick tube, and transmission cooler hose.
5. Connect all harness leads to electrical components.
6. Connect alternator warning light diode to harness connector.
7. Check all electrical systems for proper operation.



INSTALLATION - CONTINUED

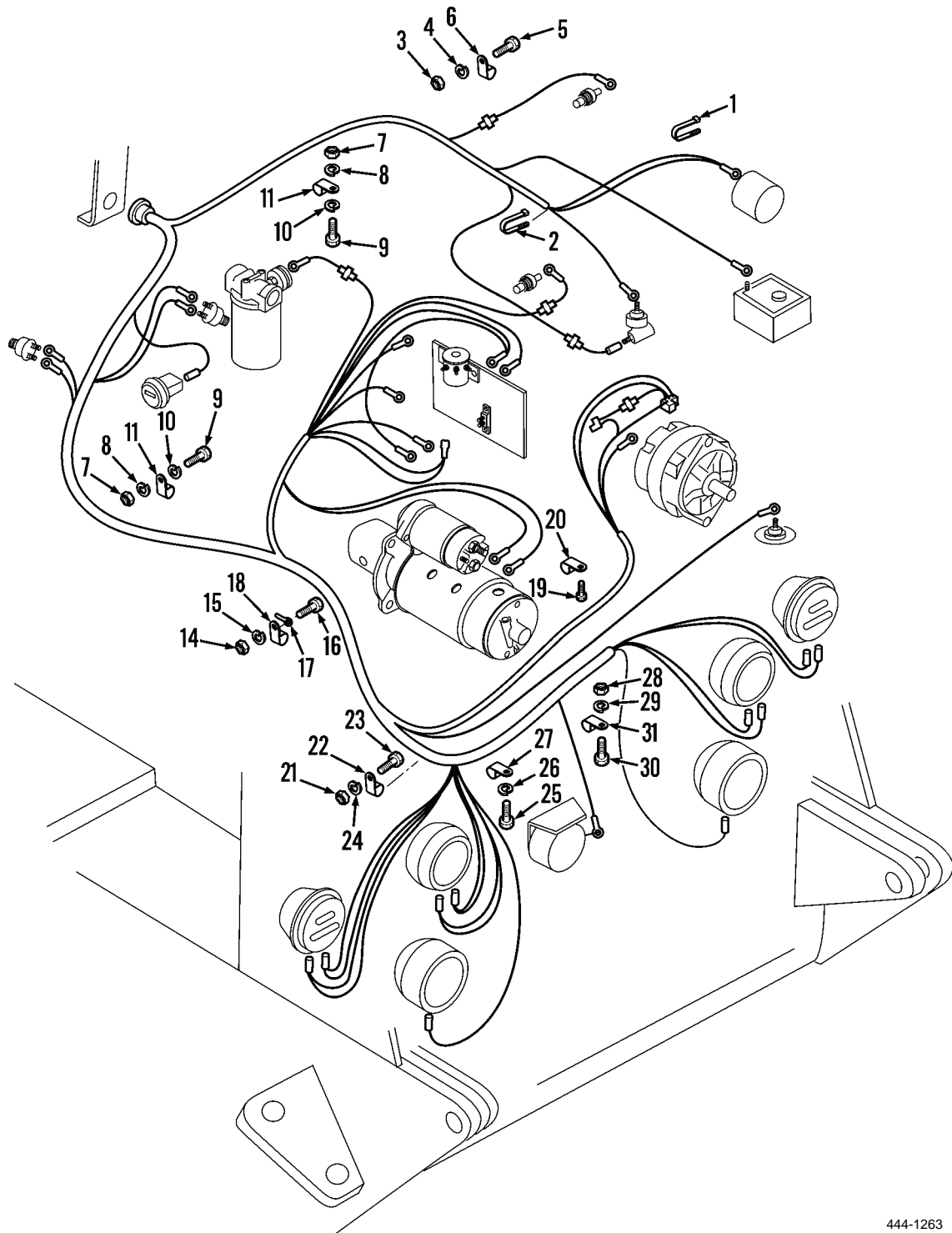

444-1263

Figure 1. Rear Wiring Harness.

END OF TASK  
 END OF WORK PACKAGE



---

## DIRECT SUPPORT MAINTENANCE INSTRUCTIONS

### REAR WIRING HARNESS REPLACEMENT (MODEL 4-390)

#### Removal, Installation

---

#### INITIAL SETUP

**Maintenance Level**

Direct Support

**Tools and Special Tools**

Tool kit, general mechanic's (Item 15, WP 0309)

Shop equipment, common no. 1 (Item 2, WP 0309)

**Materials/Parts**

Strap, tiedown (Item 32, WP 0310)

Lockwasher (3)

**References**

WP 0094

WP 0112

WP 0114

WP 0116

**References - Continued**

WP 0131

**Equipment Condition**

Vehicle parked on level surface

Engine OFF

Parking brake applied

Left and right side panels removed (WP 0179)

Battery ground cable disconnected (WP 0134)

Adapter wiring harness rear connector disconnected (WP 0244)

Rear wiring harness disconnected from relay panel wiring harness (WP 0245)

Rear wiring harness disconnected from starter (WP 0096)

---

**REMOVAL****NOTE**

- Remove wiring harness clamps and cut tiedown straps as necessary. Discard tiedown straps.
  - Tag all electrical leads before disconnecting.
1. Disconnect lead (Figure 1, Item 1) from adapter wiring harness, lead (Figure 1, Item 2) to ground, and lead (Figure 1, Item 3) to hourmeter.
  2. Disconnect front connector (Figure 1, Item 4) from left mounting bracket.
  3. Disconnect two leads (Figure 1, Item 5) from back-up alarm switch.
  4. Disconnect two leads (Figure 1, Item 6) from neutral start switch.
  5. Disconnect connector (Figure 1, Item 7) from fuel injection wiring harness.
  6. Disconnect lead (Figure 1, Item 8) from hydraulic flow restriction switch at hydraulic filter.
  7. Disconnect lead (Figure 1, Item 9) from transmission temperature switch.
  8. Disconnect lead (Figure 1, Item 10) from engine temperature switch.
  9. Disconnect lead (Figure 1, Item 11) from engine oil pressure sending unit at right side of cylinder block.
  10. Remove rear wiring harness bolt and clip from side of engine.
  11. Disconnect alternator leads (Figure 1, Item 12) (WP 0094).
  12. Disconnect harness ground (Figure 1, Item 13).
  13. Disconnect blackout light leads (Figure 1, Item 14) (WP 0114).
  14. Disconnect stop/taillight leads (Figure 1, Item 15) (WP 0116).
  15. Disconnect rear floodlight leads (Figure 1, Item 16) (WP 0112).
  16. Disconnect back-up alarm leads (Figure 1, Item 17) (WP 0131).
  17. Remove three nuts, lockwashers, and clips from radiator shroud and remove rear wiring harness (Figure 1, Item 18) from vehicle. Discard lockwashers.

**END OF TASK****INSTALLATION**

1. Position rear wiring harness (Figure 1, Item 18) on vehicle and install three clips, nuts, and new lockwashers on radiator shroud.
2. Connect back-up alarm leads (Figure 1, Item 17) to rear wiring harness (WP 0131).
3. Connect rear floodlight leads (Figure 1, Item 16) (WP 0112).
4. Connect stop/taillight leads (Figure 1, Item 15) (WP 0116).
5. Connect blackout light leads (Figure 1, Item 14) (WP 0114).
6. Connect harness ground (Figure 1, Item 13).
7. Connect alternator leads (Figure 1, Item 12) (WP 0094).
8. Install clip and bolt. Tighten bolt to 86 lb-ft (116 Nm).
9. Connect lead (Figure 1, Item 11) to oil pressure switch at center right of cylinder block.
10. Connect lead (Figure 1, Item 10) to engine temperature switch at front right of cylinder block.
11. Connect lead (Figure 1, Item 9) to transmission temperature switch.
12. Connect lead (Figure 1, Item 8) to hydraulic restriction switch at hydraulic filter.
13. Connect connector (Figure 1, Item 7) to fuel injection wiring harness at middle left side of engine compartment.

**INSTALLATION - CONTINUED**

14. Connect two leads (Figure 1, Item 6) to neutral start switch.
15. Connect two leads (Figure 1, Item 5) to back-up alarm switch.
16. Connect front connector (Figure 1, Item 4) to left mounting bracket at front left side of engine compartment.
17. Connect lead (Figure 1, Item 1) from adapter wiring harness, lead (Figure 1, Item 2) to ground, and lead (Figure 1, Item 3) to hourmeter.

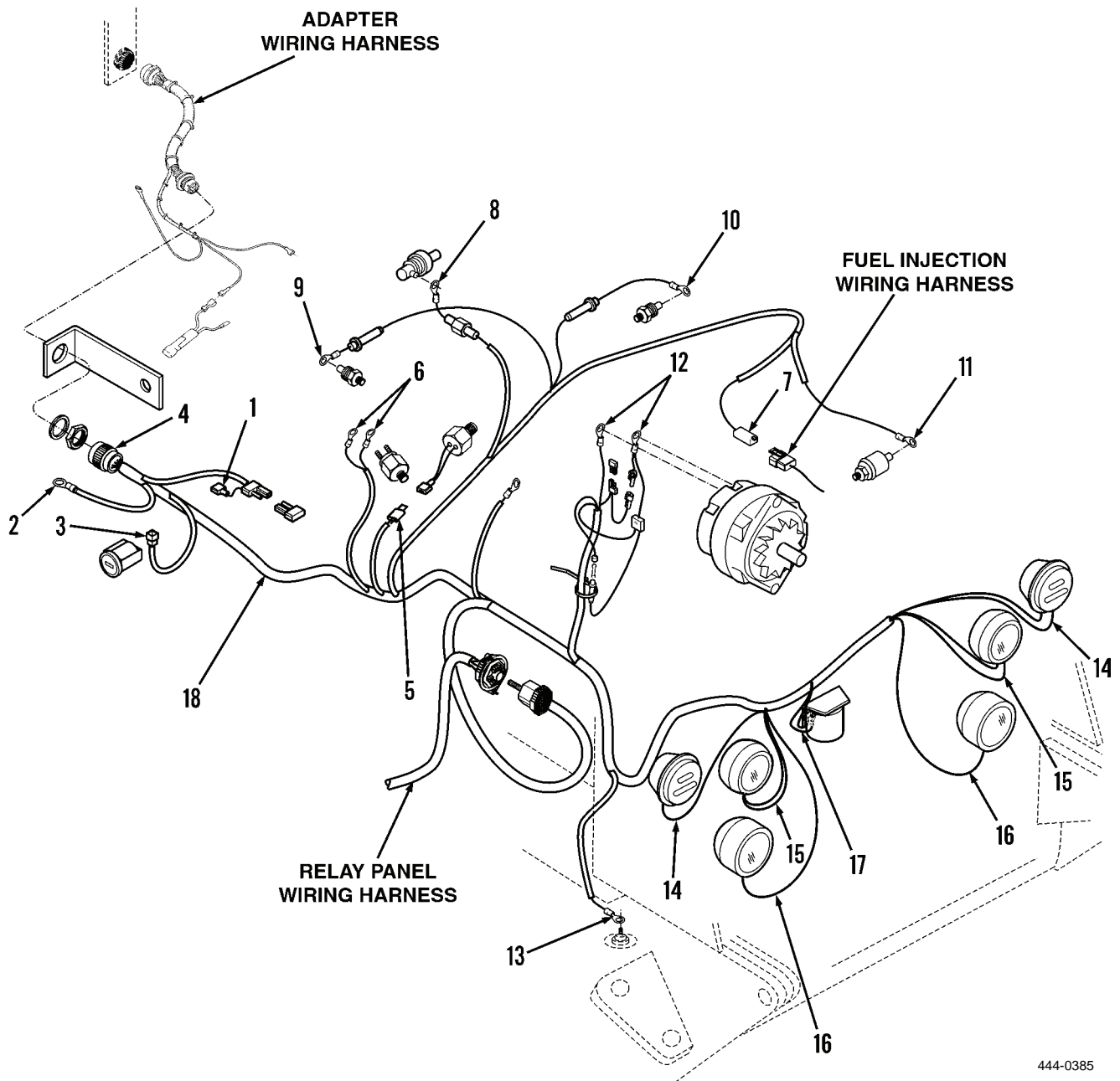

444-0385

Figure 1. Rear Wiring Harness.

END OF TASK

END OF WORK PACKAGE



---

**DIRECT SUPPORT MAINTENANCE INSTRUCTIONS**  
**ADAPTER WIRING HARNESS REPLACEMENT (MODEL 4-390)**  
**Removal, Installation**

---

**INITIAL SETUP****Maintenance Level**

Direct Support

**Tools and Special Tools**

Tool kit, general mechanic's (Item 15, WP 0309)

Shop equipment, common no. 1 (Item 2, WP 0309)

**Materials/Parts**

Strap, tiedown (Item 32, WP 0310)

Tag, marker (Item 33, WP 0310)

**Equipment Condition**

Vehicle parked on level surface

Engine OFF

Parking brake applied

Right and left side panels removed (WP 0179)

Battery ground cable disconnected (WP 0134)

Front wiring harness connector disconnected (WP  
0136)

**REMOVAL****NOTE**

Tag all harness connectors and leads.

1. Disconnect adapter wiring harness lead (Figure 1, Item 2) to hourmeter, lead (Figure 1, Item 3) to rear wiring harness, and lead (Figure 1, Item 4) to fuel injection pump wiring harness.
2. Disconnect front connector (Figure 1, Item 5) from front mounting harness.
3. Disconnect rear connector from left-side mounting bracket.
4. Remove adapter wiring harness (Figure 1, Item 1) from vehicle.

**END OF TASK****INSTALLATION**

1. Position adapter wiring harness (1) on vehicle.
2. Connect rear connector to left-side mounting bracket.
3. Connect front connector (Figure 1, Item 5) to front mounting harness.
4. Connect lead (Figure 1, Item 4) to fuel injection pump harness, lead (Figure 1, Item 3) to rear wiring harness, and lead (Figure 1, Item 2) to hourmeter.

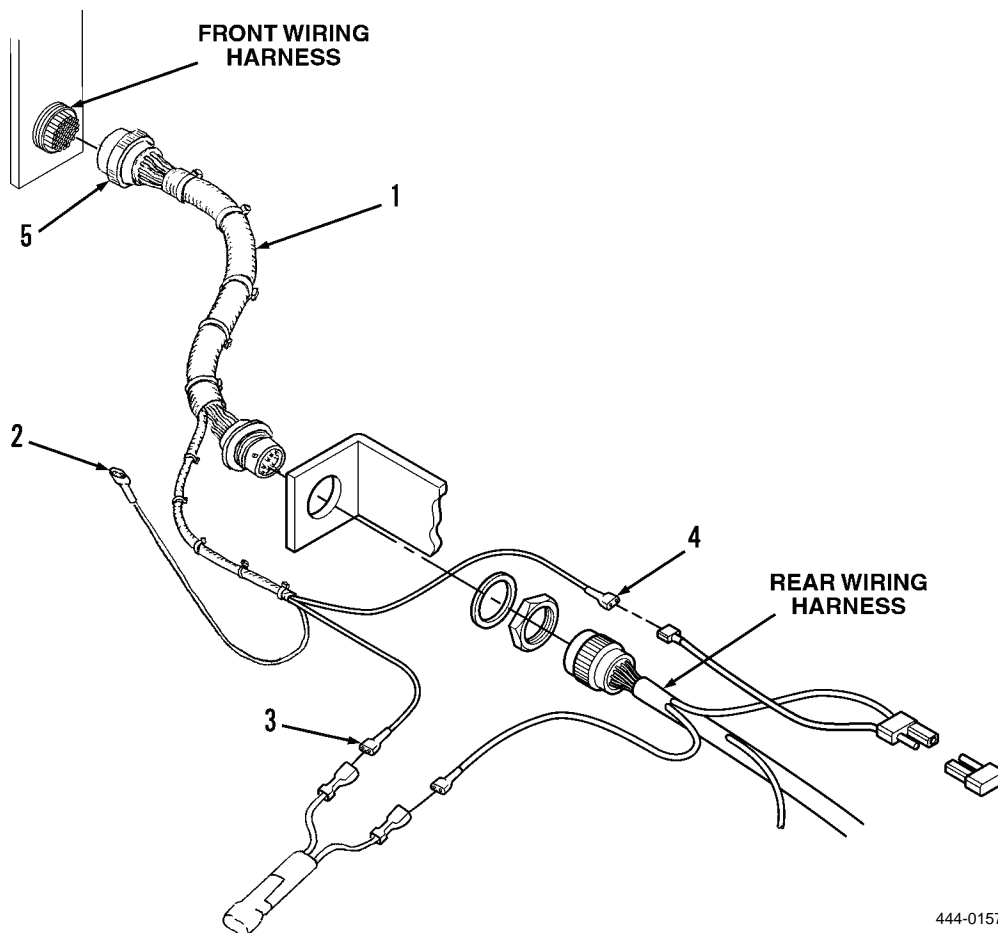

444-0157

Figure 1. Adapter Wiring Harness.

**END OF TASK**

**END OF WORK PACKAGE**



---

**DIRECT SUPPORT MAINTENANCE INSTRUCTIONS**  
**RELAY PANEL WIRING HARNESS REPLACEMENT (MODEL 4-390)**  
**Removal, Installation**

---

**INITIAL SETUP****Maintenance Level**

Direct Support

**Tools and Special Tools**

Tool kit, general mechanic's (Item 15, WP 0309)

Shop equipment, common no. 1 (Item 2, WP 0309)

**Materials/Parts**

Strap, tiedown (Item 32, WP 0310)

**References**

WP 0099

WP 0100

**References - Continued**

WP 0101

WP 0098

WP 0102

WP 0103

**Equipment Condition**

Vehicle parked on level surface

Engine OFF

Parking brake applied

Left side panel removed (WP 0179)

Battery ground cable disconnected (WP 0134)

**REMOVAL**

1. Disconnect relay panel wiring harness connector from rear wiring harness (Figure 1).
2. Disconnect relay panel harness leads. Refer to WP 0098, WP 0099, WP 0100, WP 0101, WP 0102, and WP 0103.
3. Remove relay panel wiring harness from vehicle.
4. Remove grommet from relay panel.

**END OF TASK****INSTALLATION**

1. Install grommet on relay panel.
2. Position relay panel wiring harness on vehicle.
3. Connect relay panel harness leads. Refer to WP 0099, WP 0100, WP 0101, WP 0098, WP 0102, and WP 0103.
4. Connect relay panel wiring harness connector to rear wiring harness (Figure 1).

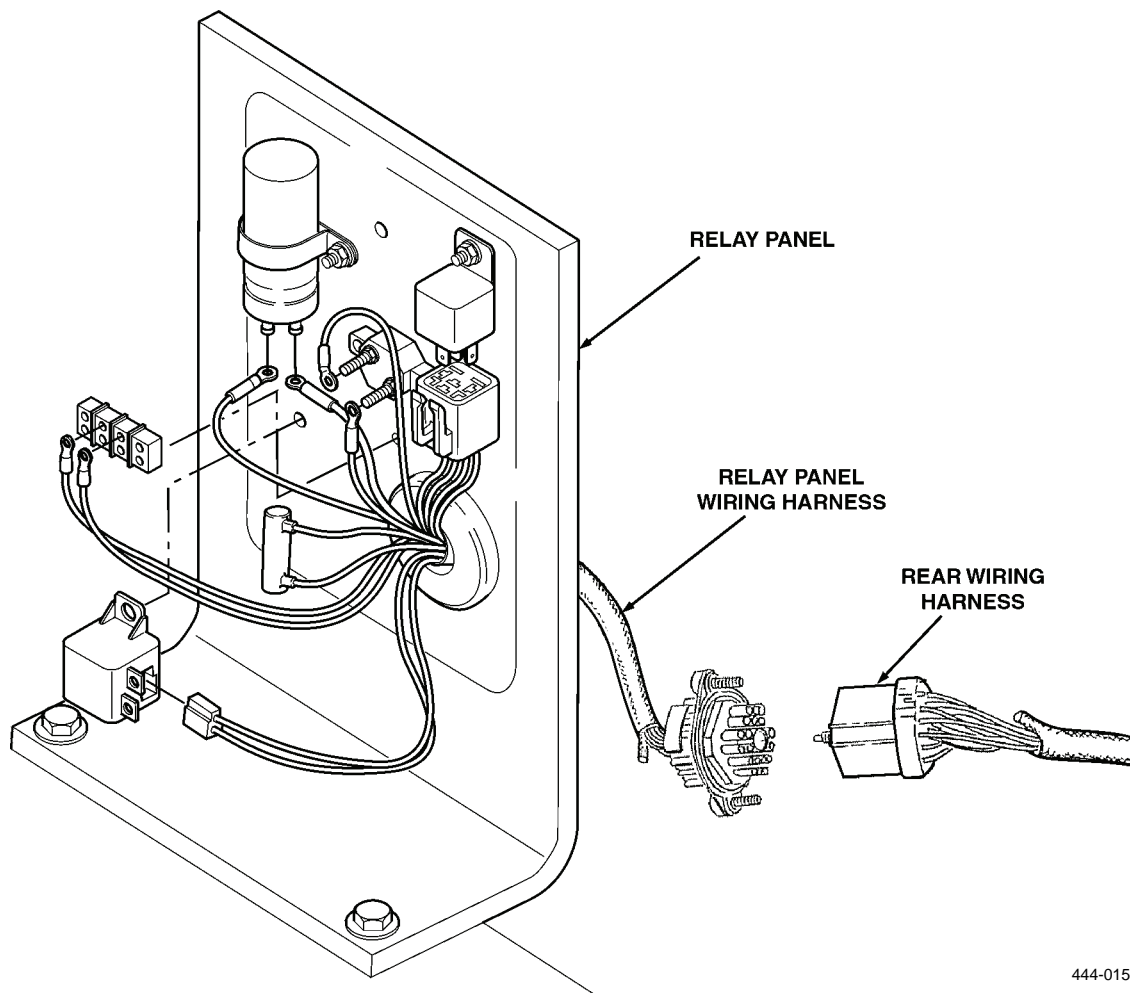

444-0158

**Figure 1. Relay Panel Wiring Harness.****END OF TASK****END OF WORK PACKAGE**

---

**DIRECT SUPPORT MAINTENANCE INSTRUCTIONS**  
**FUEL INJECTION WIRING HARNESS REPLACEMENT (MODEL 4-390)**  
**Removal, Installation**

---

**INITIAL SETUP****Maintenance Level**

Direct Support

**Tools and Special Tools**

Tool kit, general mechanic's (Item 15, WP 0309)

Shop equipment, common no. 1 (Item 2, WP 0309)

**Materials/Parts**

Strap, tiedown (Item 32, WP 0310)

**Equipment Condition**

Vehicle parked on level surface

Engine OFF

Parking brake applied

Left and right side panels removed (WP 0179)

Battery ground cable disconnected (WP 0134)

Fuel injection wiring harness leads disconnected  
from relay panel capacitor and starter relay (WP  
0098 and WP 0102)Lead from fuel injection wiring harness discon-  
nected from adapter wiring harness (WP 0244)

**REMOVAL**

1. Disconnect connector from wires of fuel injection pump (Figure 1).
2. Disconnect lead from oil pressure switch.
3. Remove connector from rear wiring harness.
4. Remove fuel injection wiring harness from engine.

**END OF TASK****INSTALLATION**

1. Position fuel injection wiring harness on engine.
2. Connect connector to rear wiring harness.
3. Connect lead to oil pressure switch.
4. Connect connector to wires of fuel injection pump (Figure 1).

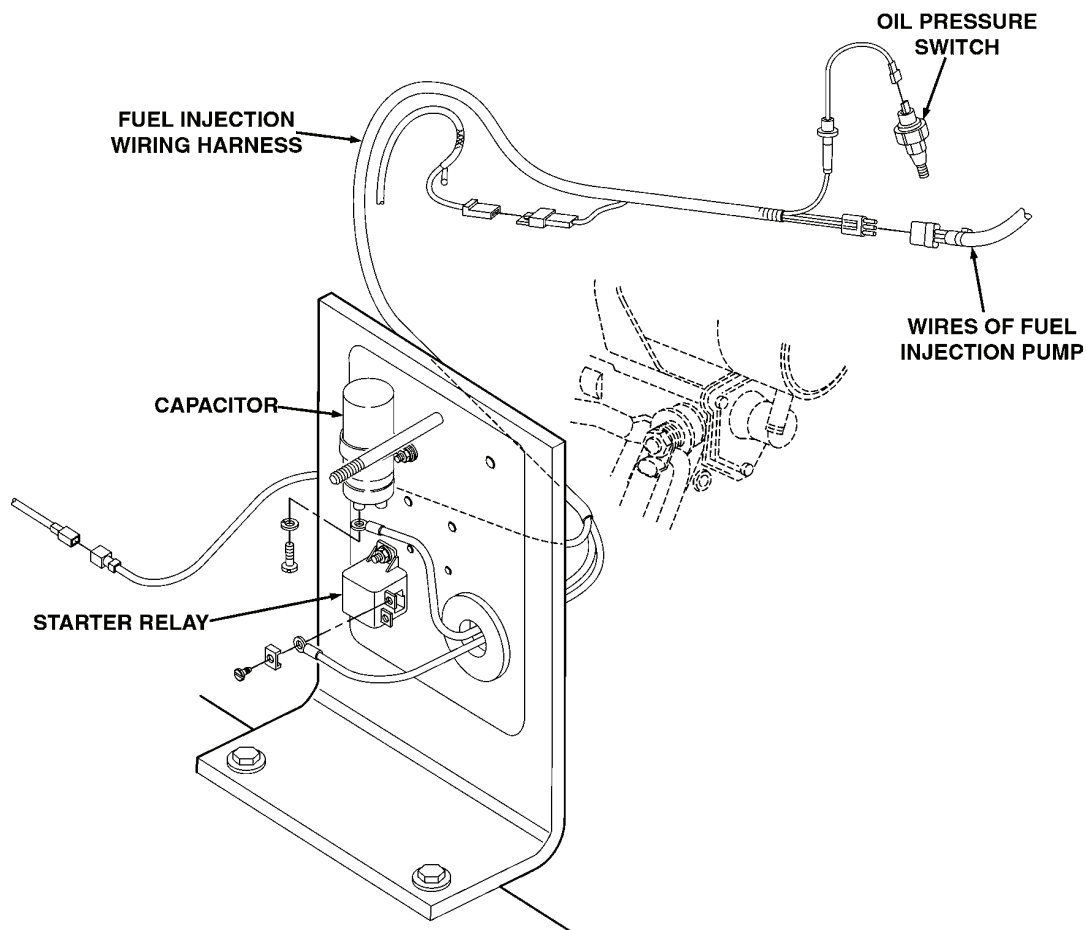

444-0139

**Figure 1. Fuel Injection Wiring Harness.****END OF TASK****END OF WORK PACKAGE**

---

**DIRECT SUPPORT MAINTENANCE INSTRUCTIONS****CABLE WIRING HARNESS REPLACEMENT (MODEL 4-390)****Removal, Installation**

---

**INITIAL SETUP****Maintenance Level**

Direct Support

**Tools and Special Tools**

Tool kit, general mechanic's (Item 15, WP 0309)

Shop equipment, common no. 1 (Item 2, WP 0309)

**Materials/Parts**

Star washer

**Equipment Condition**

Vehicle parked on level surface

Engine OFF

Parking brake applied

Left side panel removed (WP 0179)

Battery ground cable disconnected (WP 0134)

Red lead to 25 amp breaker disconnected (WP 0100)

Orange lead to starter relay disconnected (WP 0102)

---

**REMOVAL**

1. Remove screw (Figure 1, Item 2) and disconnect orange lead (Figure 1, Item 1) from starter.
2. Disconnect red lead (Figure 1, Item 4) from starter.
3. Remove star washer (Figure 1, Item 5) and nut (Figure 1, Item 6) from vehicle. Discard star washer.
4. Remove cable wiring harness (Figure 1, Item 7) from engine compartment.

**END OF TASK****INSTALLATION**

1. Position cable wiring harness (Figure 1, Item 7) in engine compartment.
2. Position red lead (Figure 1, Item 4) on starter terminal and install new star washer (Figure 1, Item 5) and nut (Figure 1, Item 6). Tighten nut to 160 to 200 lb-ft (217 to 271 Nm).
3. Position orange lead (Figure 1, Item 1) on starter terminal and install screw (Figure 1, Item 2). Tighten screw securely.

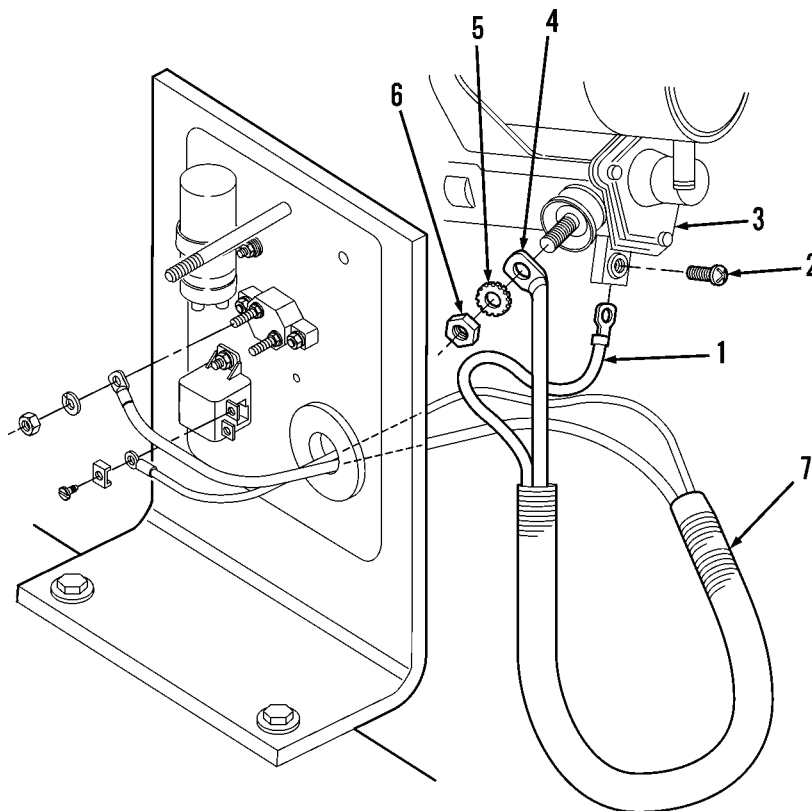

444-0386

**Figure 1. Cable Wiring Harness.****END OF TASK****END OF WORK PACKAGE**

---

## DIRECT SUPPORT MAINTENANCE INSTRUCTIONS

### TRANSMISSION PRESSURE CHECKS

#### Pressure Checks

---

#### INITIAL SETUP

##### Maintenance Level

Direct Support

##### Tools and Special Tools

Tool kit, general mechanic's (Item 15, WP 0309)

Wood blocks (2), 6 x 6 x 18 in.

##### References

WP 0038

##### Equipment Condition

Vehicle parked on level surface

Engine OFF

Wheels blocked

Parking brake applied

Left and right side panels removed (WP 0179)

---

#### PRESSURE CHECKS

#### NOTE

If vehicle cannot be driven to warm up transmission oil, block wheels and proceed to step 2; otherwise, disregard step 2.

1. Turn ignition switch to ON position.
2. Depress start switch and start engine.
3. Release parking brake.
4. Set direction selector to F position.
5. Set speed selector to 3 position.
6. Drive vehicle for 15 minutes to warm transmission oil.
7. Turn ignition switch to OFF position.
8. Turn ignition switch to ON position.
9. Depress start switch and start engine.
10. Apply parking brake.

#### WARNING

Do not allow anyone to stand in front of vehicle during the following steps. Vehicle could move, causing injury or death to personnel.

#### NOTE

Apply service brakes as required during the following steps.

11. Set direction selector to F position.
12. Set speed selector to 3 position.
13. Depress accelerator pedal half to three-quarters. Drive vehicle until transmission oil temperature is 180 to 200°F (82 to 93°C).
14. Turn ignition switch to OFF position.

**PRESSURE CHECKS - CONTINUED**

15. Remove torque converter output pressure plug (Figure 1).

**TORQUE CONVERTER  
OUTPUT PRESSURE PLUG**

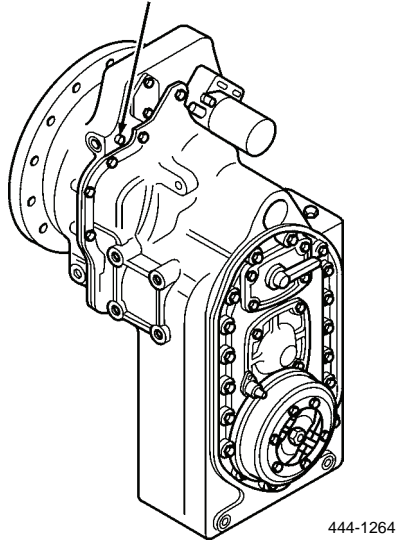

**Figure 1. Output Pressure Plug.**

16. Connect 0 to 300 PSI (0 to 2,068 kPa) pressure gage to torque converter output pressure port.
17. Position wheel chocks to block wheels.
18. Turn ignition switch to ON position.
19. Depress start switch and start engine.
20. Apply parking brake.
21. Set direction selector to N position.
22. Depress accelerator pedal. Pressure gage should indicate 25 PSI (172 kPa) minimum to 70 PSI (483 kPa) maximum at 2,000 RPM engine speed. If reading is not within specification, refer to WP 0038, *Loss of Drive in All Ranges*, step 2, and *Loss of Power and/or Loss of Drive in Any One Range*, step 1.
23. Release accelerator pedal.

**WARNING**

Do not allow anyone to stand in front of vehicle during the following steps. Vehicle could move, causing injury or death to personnel.

**NOTE**

Apply service brakes as required during the following checks.

24. With direction selector in F position, shift speed selector through 1, 2, and 3 positions while observing pressure gage. Pressure gage should indicate 180 to 220 PSI (1,241 to 1,517 kPa) with engine at idle (400 to 600 RPM). Clutch pressures must be within 5 PSI. If readings are not within specification, refer to WP 0038, *Loss of Power and/or Loss of Drive in Any One Range*, step 3.
25. Set direction selector to R position.



**PRESSURE CHECKS - CONTINUED**

26. Shift speed selector through 1, 2, and 3 positions while observing pressure gage. Pressure gage should indicate 180 to 220 PSI (1,241 to 1,517 kPa) with engine at idle (400 to 600 RPM). Clutch pressures must be within 5 psi (34 kPa). If readings are not within specification, refer to WP 0038, *Loss of Power and/or Loss of Drive in Any One Range*, step 3.
27. Turn ignition switch to OFF position.
28. Disconnect pressure gage from torque converter output pressure port.
29. Install pressure plug (Figure 1).
30. Remove lube pressure port plug (Figure 2).

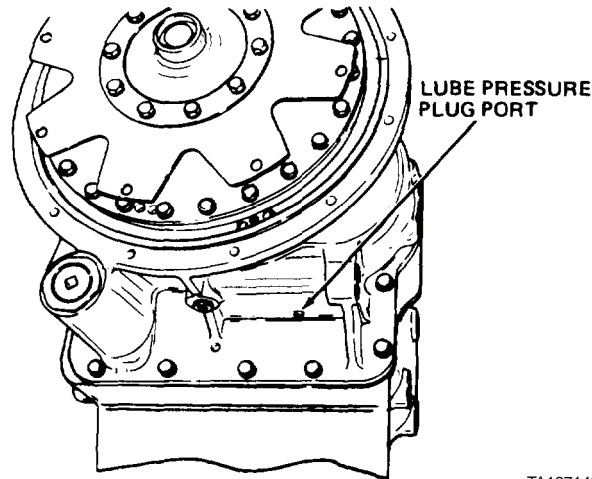

TA127148

**Figure 2. Lube Pressure Plug Port.**

31. Connect 0 to 300 PSI (0 to 2,068 kPa) pressure gage to lube pressure port.
32. Turn ignition switch to ON position.
33. Depress start switch and start engine.
34. Set direction selector to N position.
35. Depress accelerator pedal. Pressure gage should indicate 15 to 25 PSI (103 to 172 kPa) at 2,000 RPM engine speed. If reading is not within specification, refer to WP 0038, *High Transmission Oil Temperature; Loss of Drive in All Ranges, step 3; Loss of Power and/or Loss of Drive in Any One Range, step 2*.
36. Disconnect pressure gage from transmission lube pressure port.
37. Install lube pressure port plug in transmission lube pressure port (Figure 2).
38. Remove wheel chocks.

**END OF TASK****END OF WORK PACKAGE**



---

## DIRECT SUPPORT MAINTENANCE INSTRUCTIONS

### TRANSMISSION MOUNTS REPLACEMENT

Removal, Cleaning, Inspection, Installation

---

#### INITIAL SETUP

**Maintenance Level**

Direct Support

**Tools and Special Tools**

Tool kit, general mechanic's (Item 15, WP 0309)

Wood blocks (2), 6 x 6 x 18 in.

**Materials/Parts**

Cleaning compound, solvent (Item 10, WP 0310)

Rag, wiping (Item 26, WP 0310)

**Materials/Parts - Continued**

Locknut (2)

Transmission mount (2)

**Equipment Condition**

Vehicle parked on level surface

Engine OFF

Wheels blocked

Parking brake applied

Left and right side panels removed (WP 0179)

---

**REMOVAL****NOTE**

Remove and install transmission mount on one side only; then repeat procedure for remaining mount.

1. Remove locknut (Figure 1, Item 1) and washer (Figure 1, Item 2) from vehicle. Discard locknut.
2. Remove capscrew (Figure 1, Item 3).
3. Position jack under transmission housing on same side as mount being removed.
4. Raise transmission and mount bracket (Figure 1, Item 7) to relieve pressure on transmission mount (Figure 1, Item 4).
5. Remove transmission mount (Figure 1, Item 4) from vehicle.
6. Remove four capscrews (Figure 1, Item 5), washers (Figure 1, Item 6), and mount bracket (Figure 1, Item 7).

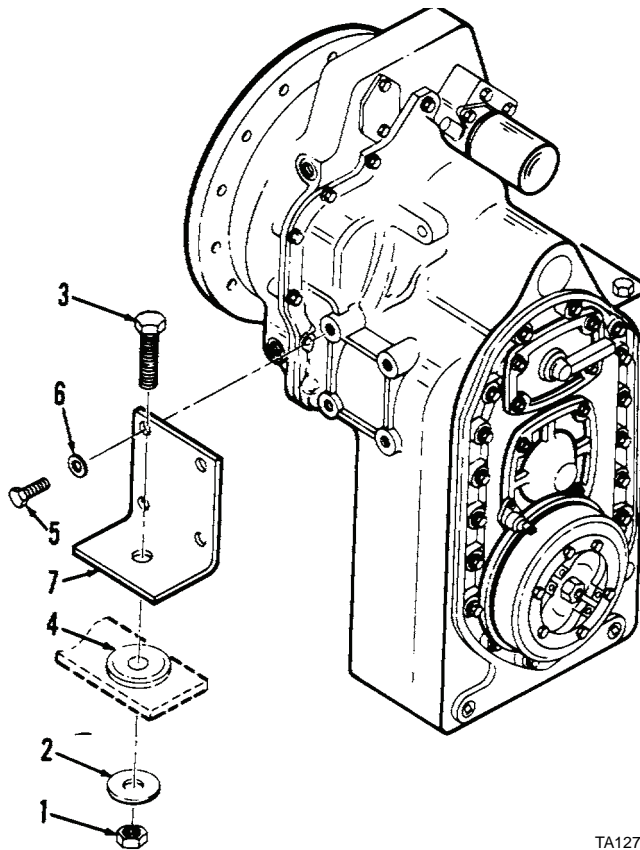

**Figure 1. Transmission Mount.**

**END OF TASK**

**CLEANING**

- Solvent cleaning compound MIL-PRF-680 Type III is an environmentally compliant and low toxic material. However, it may be irritating to the eyes and skin. Use protective gloves and goggles. Use in well-ventilated areas. Keep away from open flames and other sources of ignition. Failure to do so may result in injury or death to personnel.
- Particles blown by compressed air are hazardous. DO NOT exceed 15 psi (103 kPa) nozzle pressure when drying parts with compressed air. DO NOT direct compressed air against human skin. Make sure air stream is directed away from user and other personnel in the area. To prevent injury, user must wear protective goggles or face shield. Failure to follow this warning may result in injury to personnel.

Use solvent cleaning compound to clean all parts. Dry thoroughly with moisture-free compressed air.

**END OF TASK****INSPECTION**

1. Inspect mount bracket (Figure 1, Item 7). Replace if cracked, distorted, or worn.
2. Inspect all other parts. Replace if worn, or if threads damaged.

**END OF TASK****INSTALLATION**

1. Position mount bracket (Figure 1, Item 7) against transmission.
2. Install four washers (Figure 1, Item 6) and capscrews (Figure 1, Item 5) on mount bracket (Figure 1, Item 7) and tighten capscrews.
3. Install new transmission mount (Figure 1, Item 4) on vehicle.
4. Lower jack until mount bracket (Figure 1, Item 7) rests on transmission mount (Figure 1, Item 4).
5. Install capscrew (Figure 1, Item 3), washer (Figure 1, Item 2), and new locknut (Figure 1, Item 1) and tighten locknut until bottom of transmission mount (Figure 1, Item 4) expands to same diameter as washer (Figure 1, Item 2).

**END OF TASK****END OF WORK PACKAGE**



---

## DIRECT SUPPORT MAINTENANCE INSTRUCTIONS

### TRANSMISSION CONTROL VALVE AND MODULATION VALVE REPLACEMENT

#### Removal, Installation

---

#### INITIAL SETUP

**Maintenance Level**

Direct Support

**Tools and Special Tools**

Tool kit, general mechanic's (Item 15, WP 0309)

Shop equipment, common no. 1 (Item 2, WP 0309)

**Materials/Parts**

Cleaning compound, solvent (Item 10, WP 0310)

Rag, wiping (Item 26, WP 0310)

Gasket (2)

Lockwasher (9)

**References**

WP 0213

**Equipment Condition**

Vehicle parked on level surface

Engine OFF

Wheels blocked

Parking brake applied

Left side panel removed (WP 0179)

Control valve linkage disconnected (WP 0148)

---

#### NOTE

Refer to WP 0213 for separation of transmission from engine.

## REMOVAL

1. On left side of transmission, remove nine capscrews (Figure 1, Item 1) and lockwashers (Figure 1, Item 2). Discard lockwashers.
2. Support control valve (Figure 1, Item 3) and modulation valve assembly (Figure 1, Item 7).

## CAUTION

When performing step 3, be careful not to lose detent balls or springs.

3. Remove control valve (Figure 1, Item 3) and modulation valve assembly (Figure 1, Item 7) from transmission.
4. Remove two detent balls (Figure 1, Item 5) and springs (Figure 1, Item 6) from modulation valve assembly (Figure 1, Item 7).



Solvent cleaning compound MIL-PRF-680 Type III is an environmentally compliant and low toxic material. However, it may be irritating to the eyes and skin. Use protective gloves and goggles. Use in well-ventilated areas. Keep away from open flames and other sources of ignition. Failure to do so may result in injury or death to personnel.

5. Remove and discard gaskets (Figure 1, Items 4 and 8). Clean all traces of gasket material from mounting surfaces with solvent cleaning compound.

## END OF TASK

## INSTALLATION

1. Install two springs (Figure 1, Item 6) on modulation valve assembly (Figure 1, Item 7).
2. Install two detent balls (Figure 1, Item 5) on modulation valve assembly (Figure 1, Item 7).
3. Position new gaskets (Figure 1, Items 4 and 8) on modulation valve assembly (Figure 1, Item 7).
4. Position control valve assembly (Figure 1, Item 3) on modulation valve assembly (Figure 1, Item 7).
5. Install nine capscrews (Figure 1, Item 1) and new lockwashers (Figure 1, Item 2) through control valve (Figure 1, Item 3), modulation valve (Figure 1, Item 7), and gaskets (Figure 1, Items 4 and 8).
6. Position valves (Figure 1, Items 3 and 7) with capscrews (Figure 1, Item 1), lockwashers (Figure 1, Item 2), and gaskets (Figure 1, Items 4 and 8), against transmission, with mounting holes aligned.
7. Install nine capscrews (Figure 1, Item 1) and tighten to 23 to 25 lb-ft (31 to 34 Nm).



INSTALLATION - CONTINUED

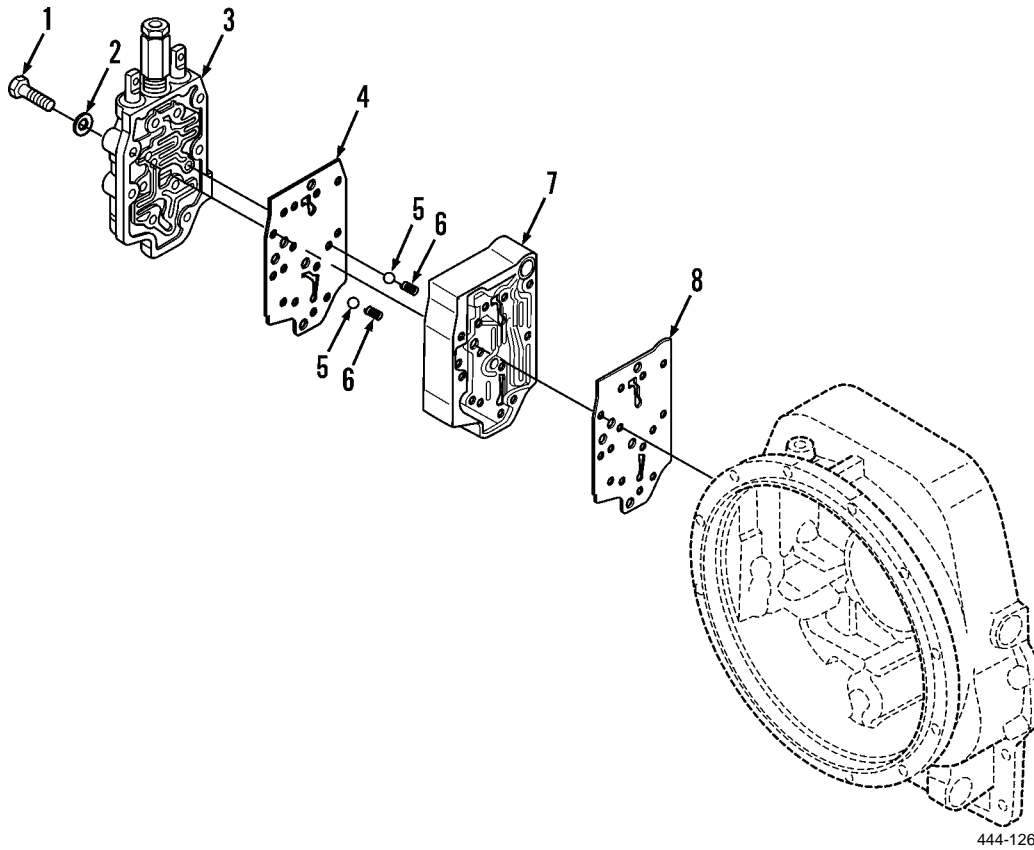

Figure 1. Transmission Control Valve.

END OF TASK

END OF WORK PACKAGE



---

## DIRECT SUPPORT MAINTENANCE INSTRUCTIONS

### TRANSMISSION CHARGING PUMP REPLACEMENT

#### Removal, Installation

---

#### INITIAL SETUP

**Maintenance Level**

Direct Support

**Tools and Special Tools**

Tool kit, general mechanic's (Item 15, WP 0309)

Shop equipment, common no. 1 (Item 2, WP 0309)

Container, 4-gal. (15-L) capacity

**Materials/Parts**

Cleaning compound, solvent (Item 10, WP 0310)

Lubricating oil, OE/HDO-10 (Item 20, WP 0310)

Rag, wiping (Item 26, WP 0310)

**Materials/Parts - Continued**

Filter assembly

Gasket

Lockwasher (3)

O-ring

**Equipment Condition**

Vehicle parked on level surface

Engine OFF

Wheels blocked

Parking brake applied

Left side panel removed (WP 0179)

---

**REMOVAL****NOTE**

Place 4-gal. (15-L) capacity container under filter assembly to catch lubricating oil.

1. Remove filter assembly (Figure 1, Item 1) at rear of transmission.
2. Remove capscrew (Figure 1, Item 2) and lockwasher (Figure 1, Item 4). Discard lockwasher.
3. Remove two capscrews (Figure 1, Item 3), nuts (Figure 1, Item 5), and lockwashers (Figure 1, Item 6). Discard lockwashers.
4. Remove charging pump assembly (Figure 1, Item 7).
5. Remove and discard O-ring (Figure 1, Item 8).

**WARNING**

Solvent cleaning compound MIL-PRF-680 Type III is an environmentally compliant and low toxic material. However, it may be irritating to the eyes and skin. Use protective gloves and goggles. Use in well-ventilated areas. Keep away from open flames and other sources of ignition. Failure to do so may result in injury or death to personnel.

6. Remove and discard gasket (Figure 1, Item 9). Clean all traces of gasket material from mounting surface with solvent cleaning compound.

**END OF TASK****INSTALLATION**

1. Position new gasket (Figure 1, Item 9) at rear of transmission.
2. Position new O-ring (Figure 1, Item 8) on charging pump assembly (Figure 1, Item 7).
3. Position charging pump assembly (Figure 1, Item 7) on mounting studs.
4. Install two nuts (Figure 1, Item 5) and new lockwashers (Figure 1, Item 6) on mounting studs. Tighten nuts to 41 to 45 lb-ft (56 to 61 Nm).
5. Install three capscrews (Figure 1, Items 2 and 3) and new lockwasher (Figure 1, Item 4) on charging pump assembly (Figure 1, Item 7). Tighten capscrews to 37 to 41 lb-ft (50 to 56 Nm).
6. Apply light film of lubricating oil to gasket, then install filter assembly (Figure 1, Item 1) on transmission. Tighten filter assembly to 20 to 25 lb-ft (27 to 34 Nm).

INSTALLATION - CONTINUED

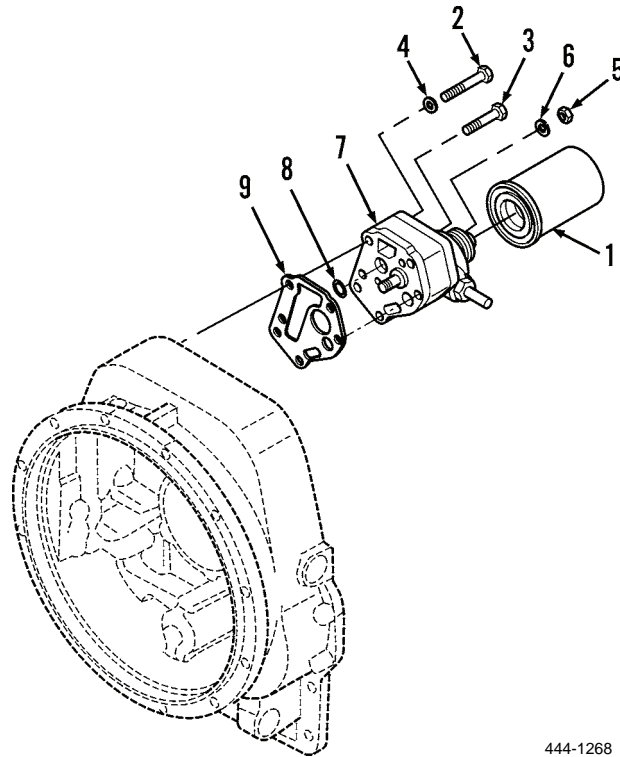

444-1268

Figure 1. Transmission Charging Pump.

END OF TASK

END OF WORK PACKAGE



## DIRECT SUPPORT MAINTENANCE INSTRUCTIONS

### TRANSMISSION OIL COOLER REPAIR

#### Cleaning, Inspection/Repair

#### INITIAL SETUP

##### Maintenance Level

Direct Support

##### Tools and Special Tools

Tool kit, general mechanic's (Item 15, WP 0309)  
Shop equipment, common no. 1 (Item 2, WP 0309)

##### Materials/Parts

Cleaning compound, solvent (Item 10, WP 0310)  
Lubricating oil, OE/HDO-10 (Item 20, WP 0310)

##### Materials/Parts - Continued

Rag, wiping (Item 26, WP 0310)

##### Equipment Condition

Vehicle parked on level surface  
Engine OFF  
Wheels blocked  
Parking brake applied  
Transmission oil cooler removed (WP 0153)

#### CLEANING



**WARNING**



- Solvent cleaning compound MIL-PRF-680 Type III is an environmentally compliant and low toxic material. However, it may be irritating to the eyes and skin. Use protective gloves and goggles. Use in well-ventilated areas. Keep away from open flames and other sources of ignition. Failure to do so may result in injury or death to personnel.
- Particles blown by compressed air are hazardous. DO NOT exceed 30 PSI (207 kPa) nozzle pressure when cleaning parts with compressed air. DO NOT direct compressed air against human skin. Make sure air stream is directed away from user and other personnel in the area. To prevent injury, user must wear protective goggles or face shield. Failure to follow this warning may result in injury to personnel.

1. Use solvent cleaning compound to clean exterior of transmission oil cooler.

#### CAUTION

Do not use flushing compounds in step 2.

2. Clean interior by back flushing with clean lubricating oil and compressed air until all foreign material is removed, then steam clean interior.

#### END OF TASK

#### INSPECTION/REPAIR

Inspect transmission oil cooler for broken welds and brazed joints. Repair by welding and brazing broken joints. If not feasible to repair, replace transmission oil cooler.

#### END OF TASK

#### END OF WORK PACKAGE





---

## DIRECT SUPPORT MAINTENANCE INSTRUCTIONS

### FRONT AXLE REPLACEMENT

#### Removal, Installation/Replacement

---

#### INITIAL SETUP

**Maintenance Level**

Direct Support

**Tools and Special Tools**

Tool kit, general mechanic's (Item 15, WP 0309)  
Shop equipment, common no. 1 (Item 2, WP 0309)  
Chain hoist, 10-ton capacity  
Jack stands (2), 4-ton capacity  
Roller jack, 1-ton capacity  
Wood blocks (2), 6 x 6 x 18 in.

**Materials/Parts**

Cap set, protective (Item 9, WP 0310)  
Cleaning compound, solvent (Item 10, WP 0310)  
Rag, wiping (Item 26, WP 0310)  
Hose (P/N SAE30R2TYPE1-1-41D), 27 in. long

**Personnel Required**

Two

**References**

WP 0157

**Equipment Condition**

Vehicle parked on level surface  
Engine OFF  
Rear wheels blocked  
Parking brake applied  
Shipping lock pin installed (WP 0044)  
Front drive shaft assembly disconnected from front axle assembly differential companion yoke (WP 0154)  
Front chassis raised (use chain hoist) and securely blocked (use jack stands)  
Front wheels and tires removed (WP 0169)  
Brake hoses, lines, and fittings disconnected from front axle assembly housing and wheel cylinders (WP 0164)

---

**REMOVAL****NOTE**

Cap all openings.

1. Position roller jack under axle assembly.
2. Loosen clamp (Figure 1, Item 1) on vent hose (Figure 1, Item 2).
3. Disconnect vent hose (Figure 1, Item 2) from connector (Figure 1, Item 3).
4. Remove connector (Figure 1, Item 3) from axle housing.
5. Remove eight nuts (Figure 1, Item 4), washers (Figure 1, Items 5 and 6), and capscrews (Figure 1, Item 7) from two axle support plates (Figure 1, Item 8).
6. Remove two axle support plates (Figure 1, Item 8) from vehicle.
7. Lower front axle assembly (Figure 1, Item 9) from vehicle.

**END OF TASK****INSTALLATION/REPLACEMENT**

1. Position front axle assembly (Figure 1, Item 9) under vehicle using roller jack and raise axle into position.
2. Position two axle support plates (Figure 1, Item 8) and install eight capscrews (Figure 1, Item 7), washers (Figure 1, Items 6 and 5), and nuts (Figure 1, Item 4).
3. Install connector (Figure 1, Item 3) on axle housing.
4. Position clamp (Figure 1, Item 1) on vent hose (Figure 1, Item 2).
5. Connect vent hose (Figure 1, Item 2) to connector (Figure 1, Item 3). If necessary, make hose from P/N SAE30R2TYPE1-1-41D, cut to 27 in. (686 mm) long.
6. Tighten clamp (Figure 1, Item 1) on vent hose (Figure 1, Item 2).
7. Install axle assembly fill plug in axle housing and tighten. Check lubricant level and add if necessary (WP 0157, *Service*, step 4).

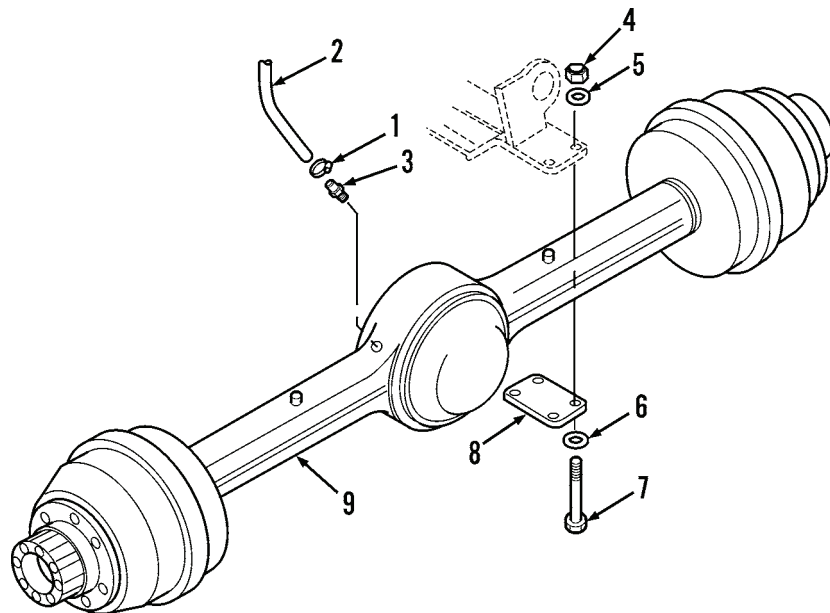

444-1269

**Figure 1. Front Axle.**

**END OF TASK****END OF WORK PACKAGE**

---

## DIRECT SUPPORT MAINTENANCE INSTRUCTIONS

### REAR AXLE REPLACEMENT

#### Removal, Installation

---

#### INITIAL SETUP

**Maintenance Level**

Direct Support

**Tools and Special Tools**

Tool kit, general mechanic's (Item 15, WP 0309)  
Shop equipment, common no. 1 (Item 2, WP 0309)  
Chain hoist, 10-ton capacity  
Jack stands (2), 4-ton capacity  
Roller jack, 1-ton capacity  
Wood blocks (2), 6 x 6 x 18 in.

**Materials/Parts**

Cleaning compound, solvent (Item 10, WP 0310)  
Rag, wiping (Item 26, WP 0310)  
Hose (P/N SAE30R2TYPE1-1-41D), 32 in. long

**Personnel Required**

Two

**References**

WP 0157

**Equipment Condition**

Vehicle parked on level surface  
Engine OFF  
Front wheels blocked  
Parking brake applied  
Shipping lock pin installed (WP 0044)  
Rear drive shaft assembly disconnected from rear axle assembly differential companion yoke (WP 0156)  
Rear chassis raised (use chain hoist) and securely blocked (use jack stands)  
Rear wheels and tires removed (WP 0169)  
Brake hoses, lines, and fittings disconnected from front axle assembly housing and wheel cylinders (WP 0164)

---

**REMOVAL**

1. Position roller jack under rear axle assembly (Figure 2, Item 9).
2. Loosen clamp (Figure 2, Item 1) on vent hose (Figure 2, Item 2).
3. Disconnect vent hose (Figure 2, Item 2) from connector (Figure 2, Item 3).
4. Remove connector (Figure 2, Item 3) from axle housing.
5. Remove eight nuts (Figure 2, Item 4), washers (Figure 2, Items 5 and 6), and capscrews (Figure 2, Item 7) from two axle support plates (Figure 2, Item 8).
6. Remove two axle support plates (Figure 2, Item 8) from vehicle.
7. Lower rear axle assembly (Figure 2, Item 9) from vehicle.

**END OF TASK****INSTALLATION**

1. Use roller jack to position rear axle assembly (Figure 2, Item 9) under vehicle and raise rear axle assembly into position.
2. Position two axle support plates (Figure 2, Item 8) and install eight capscrews (Figure 2, Item 7), washers (Figure 2, Items 6 and 5), and nuts (Figure 2, Item 4). Tighten nuts.
3. Install connector (Figure 2, Item 3) on axle housing.
4. Position clamp (Figure 2, Item 1) on vent hose (Figure 2, Item 2).
5. Connect vent hose (Figure 2, Item 2) to connector (Figure 2, Item 3). If necessary, make hose from FSCM 81343 P/N SAE30R2TYPE1-1-41D; cut to 32 in. (813 mm) long.
6. Tighten clamp (Figure 2, Item 1) on vent hose (Figure 2, Item 2).
7. Install axle assembly fill plug on axle housing.
8. Check lubricant level and add if necessary (WP 0157, *Service*, step 4).

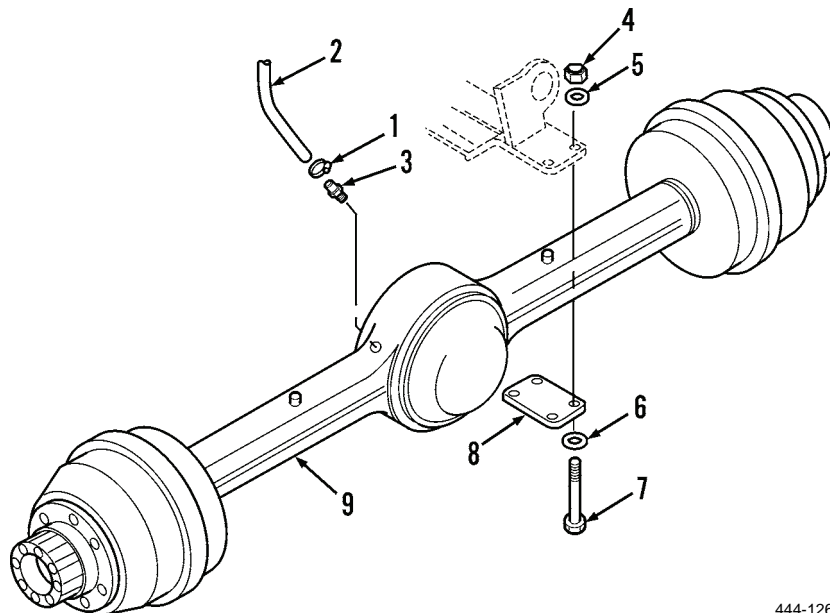

444-1269

**Figure 2. Rear Axle.****END OF TASK****END OF WORK PACKAGE**

---

## DIRECT SUPPORT MAINTENANCE INSTRUCTIONS

### FRONT AXLE DIFFERENTIAL CARRIER REPLACEMENT Removal, Axle Housing Cleaning, Axle Housing Inspection, Installation

---

#### INITIAL SETUP

##### Maintenance Level

Direct Support

##### Personnel Required

Two

##### Tools and Special Tools

Tool kit, general mechanic's (Item 15, WP 0309)  
Shop equipment, common no. 1 (Item 2, WP 0309)  
Container, 4-gal. capacity  
Jack stands (2), 4-ton capacity  
Roller jack, 1-ton capacity  
Wood blocks (3), 6 x 6 x 18 in.

##### References

WP 0156  
WP 0157  
WP 0160

##### Materials/Parts

Adhesive, silicone (Item 2, WP 0310)  
Cleaning compound, solvent (Item 10, WP 0310)  
Cloth, crocus (Item 12, WP 0310)  
Lubricating oil, gear (Item 22, WP 0310)  
Rag, wiping (Item 26, WP 0310)

##### Equipment Condition

Vehicle parked on level surface  
Engine OFF  
Rear wheels blocked  
Parking brake applied  
Shipping lock pin installed (WP 0044)  
Front drive shaft assembly disconnected from front  
axle assembly differential companion yoke (WP  
0154)  
Brake line removed (WP 0164, *Removal*, step 5)

---

**REMOVAL****NOTE**

Position 4-gal. (15-L) container under drain plug.

1. Remove drain plug and drain lubricant (Figure 1).

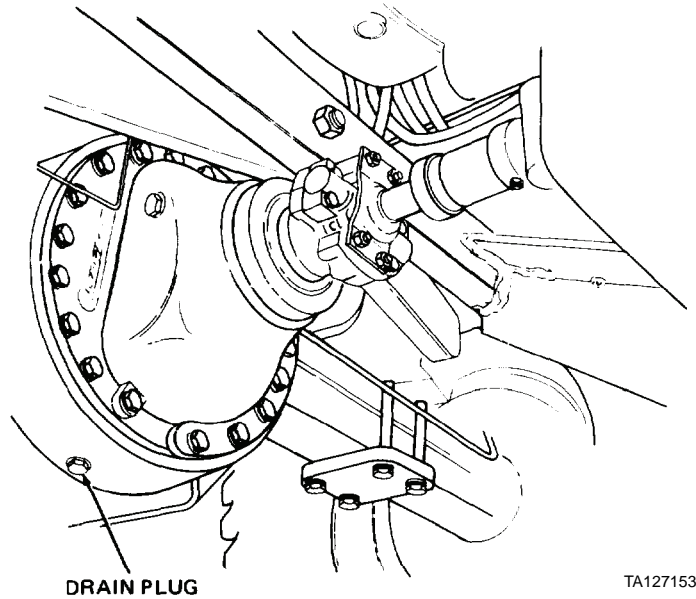

**Figure 1. Front Axle Differential Carrier.**

2. Remove two axle shafts (WP 0160, *Removal*, steps 1 through 3).
3. Position roller jack under axle housing.

**REMOVAL - CONTINUED****NOTE**

Step 4 prevents assembly from falling after remaining capscrews are removed and assembly is broken loose from housing.

4. Loosen, but do not remove, two capscrews from differential carrier assembly.
5. Remove 14 capscrews and washers from differential carrier assembly (Figure 2).
6. Loosen differential carrier assembly by striking with rawhide mallet.
7. Remove two capscrews and washers loosened in step 4.

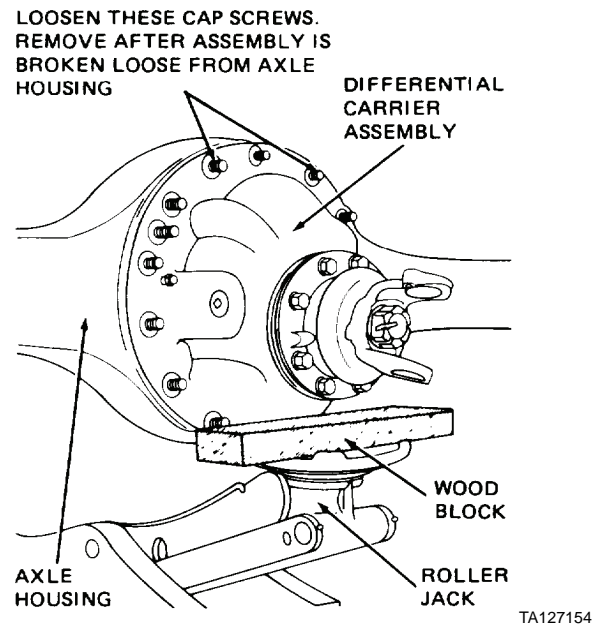

**Figure 2. Differential Carrier Assembly.**

8. Remove differential carrier assembly from vehicle using roller jack with wood block.

**END OF TASK**

## AXLE HOUSING CLEANING



**WARNING**

- Solvent cleaning compound MIL-PRF-680 Type III is an environmentally compliant and low toxic material. However, it may be irritating to the eyes and skin. Use protective gloves and goggles. Use in well-ventilated areas. Keep away from open flames and other sources of ignition. Failure to do so may result in injury or death to personnel.
- Particles blown by compressed air are hazardous. DO NOT exceed 15 PSI (103 kPa) nozzle pressure when drying parts with compressed air. DO NOT direct compressed air against human skin. Make sure air stream is directed away from user and other personnel in the area. To prevent injury, user must wear protective goggles or face shield. Failure to follow this warning may result in injury to personnel.

Remove accumulation of dirt, grit, or gum from axle housing bowl. Clean with solvent cleaning compound. Dry with moisture-free compressed air. Remove all traces of adhesive from mounting surface.

### END OF TASK

## AXLE HOUSING INSPECTION

Inspect differential carrier bore for cracks, nicks, and burrs at machined surface. Remove nicks and burrs with crocus cloth.

### END OF TASK

## INSTALLATION

1. Use roller jack to position differential carrier assembly under vehicle.
2. Apply adhesive around mounting surface of housing bore.
3. Position differential carrier assembly in housing bore.

### NOTE

Be sure correct size capscrew is installed in mounting hole as shown (Figure 3).

4. Install four capscrews and washers equally spaced on differential carrier and tighten alternately to draw assembly into housing bore (Figure 3).
5. Install 12 capscrews and washers on differential carrier assembly.

### NOTE

Tighten 7/16-14 capscrews to 70 to 80 lb-ft (95 to 108 Nm); tighten 1/2-13 capscrews to 110 to 130 lb-ft (149 to 176 Nm).

6. Remove roller jack from under axle housing.
7. Install drain plug.
8. Install two axle shafts (WP 0160, *Installation*, step 6).
9. Fill axle assembly with lubricating oil (WP 0157, *Service*, steps 4 and 5).
10. Connect front drive shaft assembly to differential companion yoke (WP 0154, *Assembly*, step 1).



## INSTALLATION - CONTINUED

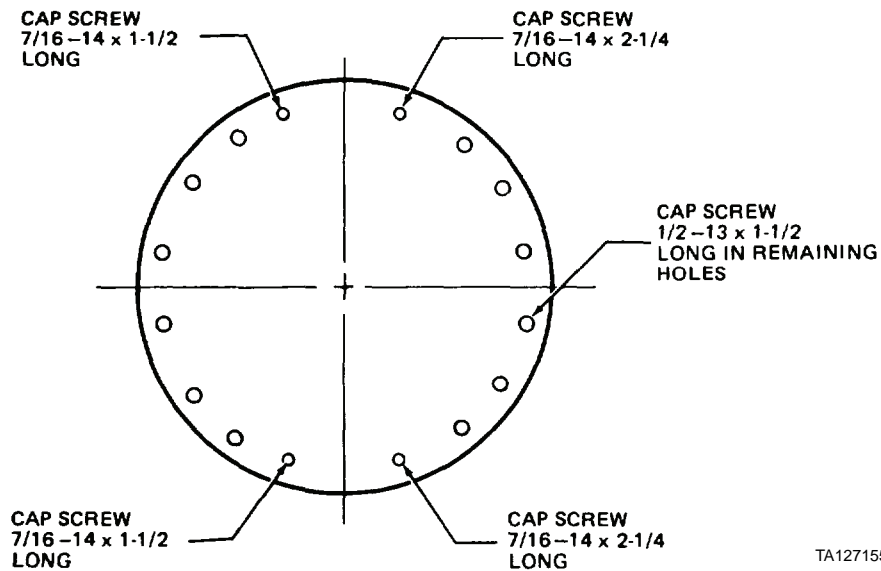

Figure 3. Installing Capscrews.

11. Disconnect rear drive shaft assembly (WP 0156, *Removal*, step 1).
12. Raise tires and wheels off ground and place jack stands under front axle housing.

**WARNING**

Do not allow anyone to stand in front of vehicle during step 13; be sure front axle is securely blocked. Vehicle could slip off jack stands and hit anyone standing in front, causing injury or death to personnel.

13. Start engine and operate at idle speed.
14. Place transmission direction selector in F (Forward) position and place speed selector in 3 (Third) position.
15. Disengage parking brake and operate vehicle for 5 minutes at full throttle to assure satisfactory lubrication of differential carrier assembly parts.
16. Turn engine OFF and apply parking brake.
17. Remove jack stands and lower front axle.
18. Connect rear drive shaft assembly (WP 0156, *Installation*, step 2).

**END OF TASK****END OF WORK PACKAGE**



---

## DIRECT SUPPORT MAINTENANCE INSTRUCTIONS

### REAR AXLE DIFFERENTIAL CARRIER REPLACEMENT

Removal, Axle Housing Cleaning, Axle Housing Inspection, Installation

---

#### INITIAL SETUP

##### Maintenance Level

Direct Support

##### Tools and Special Tools

Tool kit, general mechanic's (Item 15, WP 0309)  
Shop equipment, common no. 1 (Item 2, WP 0309)  
Container, 4-gal. capacity  
Jack stands (2), 4-ton capacity  
Roller jack, 1-ton capacity  
Wood blocks (2), 6 x 6 x 18 in.

##### Materials/Parts

Adhesive, silicone (Item 2, WP 0310)  
Cleaning compound, solvent (Item 10, WP 0310)  
Cloth, crocus (Item 12, WP 0310)  
Lubricating oil, gear (Item 22, WP 0310)  
Rag, wiping (Item 26, WP 0310)

##### Personnel Required

Two

##### References

WP 0154  
WP 0155  
WP 0157  
WP 0160

##### Equipment Condition

Vehicle parked on level surface  
Engine OFF  
Rear wheels blocked  
Parking brake applied  
Shipping lock pin installed (WP 0044)  
Rear drive shaft assembly disconnected from rear axle assembly differential companion yoke (WP 0156)  
Brake line removed (WP 0164, *Removal*, step 6)  
Rear axle assembly mounting hardware removed and rear chassis raised 12 in. above rear axle assembly and blocked (WP 0254)

---

**REMOVAL****NOTE**

Position 4-gal. (15-L) container under drain plug under axle housing.

1. Remove drain plug and drain lubricating oil (Figure 1).

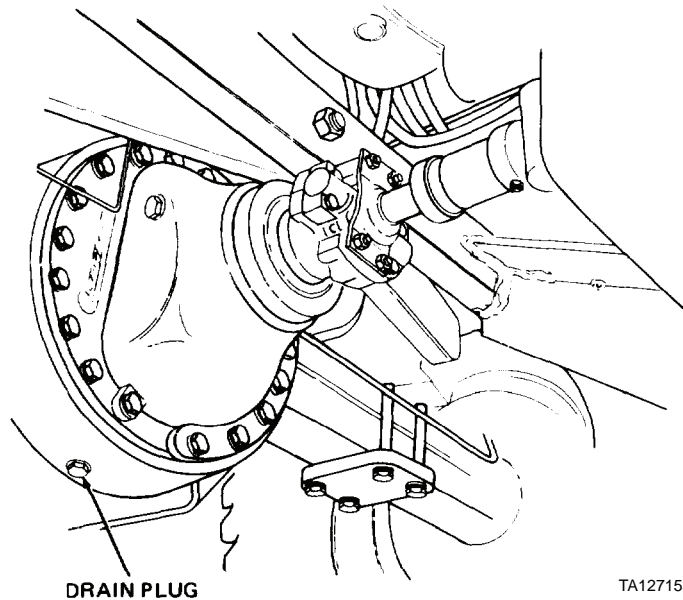

**Figure 1. Rear Axle Differential.**

2. Remove two axle shafts (WP 0160, *Removal*, step 3).
3. Position roller jack under axle housing.

**NOTE**

Step 4 prevents assembly from falling after remaining capscrews are removed and assembly broken loose from housing.

4. Loosen two capscrews in differential carrier (Figure 2).
5. Remove 14 capscrews and washers from differential carrier.
6. Loosen differential carrier assembly by striking with rawhide mallet.
7. Remove two capscrews and washers loosened in step 4.

## REMOVAL - CONTINUED

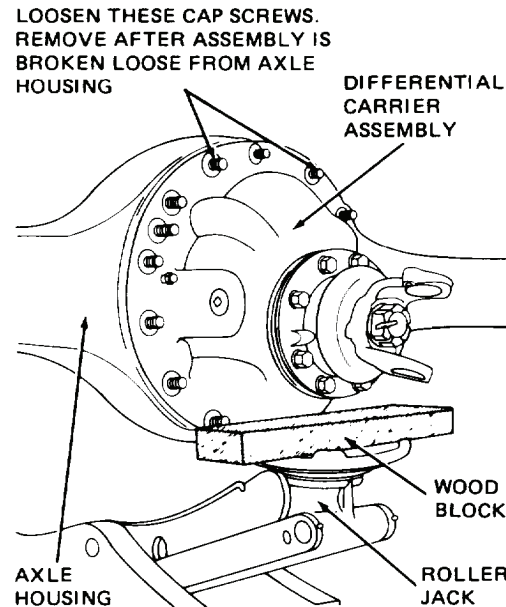

TA127154

Figure 2. Differential Carrier Assembly.

8. Remove differential carrier assembly from vehicle.

## END OF TASK

## AXLE HOUSING CLEANING



WARNING



- Solvent cleaning compound MIL-PRF-680 Type III is an environmentally compliant and low toxic material. However, it may be irritating to the eyes and skin. Use protective gloves and goggles. Use in well-ventilated areas. Keep away from open flames and other sources of ignition. Failure to do so may result in injury or death to personnel.
- Particles blown by compressed air are hazardous. DO NOT exceed 15 PSI (103 kPa) nozzle pressure when drying parts with compressed air. DO NOT direct compressed air against human skin. Make sure air stream is directed away from user and other personnel in the area. To prevent injury, user must wear protective goggles or face shield. Failure to follow this warning may result in injury to personnel.

Remove accumulation of dirt, grit, and gum from axle housing bowl. Clean with solvent cleaning compound. Dry with moisture-free compressed air. Remove all traces of adhesive from mounting surface.

## END OF TASK

## AXLE HOUSING INSPECTION

Inspect differential carrier bore for cracks, nicks, and burrs at machined surface. Remove nicks and burrs with crocus cloth.

## END OF TASK

## INSTALLATION

1. Use roller jack to position differential carrier assembly under vehicle (Figure 3).
2. Apply adhesive around mounting surface of housing bore.
3. Position differential carrier assembly in housing bore (Figure 3).

## NOTE

Be sure to install correct size capscrew in mounting hole as shown.

4. Install four capscrews and washers on differential carrier assembly equally spaced and tighten alternately to draw assembly into housing bore.

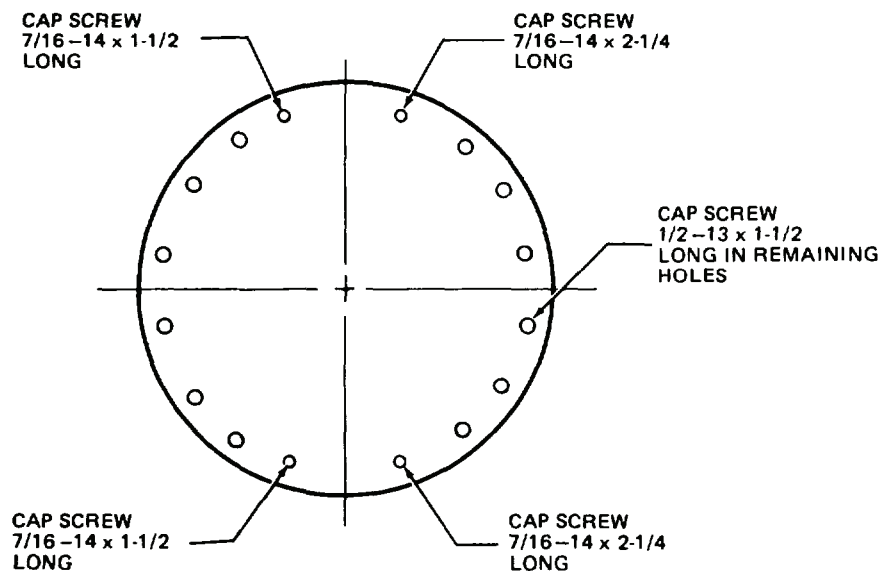

Figure 3. Installing Capscrews.

5. Install 12 capscrews and washers on differential carrier assembly.

## NOTE

Tighten 7/16-14 capscrews to 70 to 80 lb-ft (95 to 108 Nm). Tighten 1/2-13 capscrews to 110 to 130 lb-ft (149 to 176 Nm).

6. Install drain plug in axle housing.
7. Install two axle shafts (WP 0160, *Installation*, steps 6 through 8).
8. Fill differential carrier assembly with lubricating oil (WP 0157, *Service*, steps 2 and 4).
9. Connect rear drive shaft assembly to differential companion yoke (WP 0156, *Installation*, step 9).
10. Disconnect center drive shaft assembly (WP 0156, *Removal*, step 1).
11. Raise tires and wheels off ground and place jack stands under rear axle housing.

**INSTALLATION - CONTINUED****WARNING**

Do not allow anyone to stand in front of vehicle during step 12; be sure front axle is securely blocked. Vehicle could slip off jack stands and hit personnel standing in front, causing injury or death to personnel.

12. Start engine and operate at idle speed.
13. Place transmission direction selector in F (Forward) position and place speed selector in 3 (Third) position.
14. Disengage parking brake and operate vehicle for 5 minutes at full throttle to ensure satisfactory lubrication of differential carrier assembly parts.
15. Turn engine OFF and apply parking brake.
16. Remove jack stands and lower rear axle.
17. Connect center drive shaft assembly (WP 0155, *Installation*, step 10).

**END OF TASK****END OF WORK PACKAGE**





---

## DIRECT SUPPORT MAINTENANCE INSTRUCTIONS

### STEERING WHEEL AND STEERING COLUMN MAINTENANCE

Removal, Disassembly, Cleaning, Inspection, Assembly, Installation

---

#### INITIAL SETUP

##### Maintenance Level

Direct Support

##### Tools and Special Tools

Tool kit, general mechanic's (Item 15, WP 0309)  
Shop equipment, common no. 1 (Item 2, WP 0309)  
Brass rod, 5/16-in. diameter

##### Materials/Parts

Cleaning compound, solvent (Item 10, WP 0310)  
Grease, automotive and artillery (Item 17, WP 0310)

##### Materials/Parts - Continued

Lubricating oil, OE/HDO-10 (Item 20, WP 0310)  
Rag, wiping (Item 26, WP 0310)  
Dowel pin (2)  
Lockwasher  
Seal

##### Equipment Condition

Vehicle parked on level surface  
Engine OFF  
Horn switch removed from steering wheel (WP 0129)

---

**REMOVAL**

Remove nut (Figure 1, Item 1) and steering wheel (Figure 1, Item 4) from top of steering column. Use suitable wheel puller to remove steering wheel if necessary.

**END OF TASK****DISASSEMBLY**

1. Remove nut (Figure 1, Item 5), lockwasher (Figure 1, Item 6), and capscrew (Figure 1, Item 7) from clamp (Figure 1, Item 20). Discard lockwasher.
2. Remove four screws (Figure 1, Item 8), cover (Figure 1, Item 9), and seal (Figure 1, Item 10) from jacket tube (Figure 1, Item 15). Discard seal.
3. Remove two screws (Figure 1, Item 11), flat washers (Figure 1, Item 12), and horn contact assembly (Figure 1, Item 13) from jacket tube (Figure 1, Item 15).
4. Remove jacket tube (Figure 1, Item 15) from vehicle.
5. Remove bushing (Figure 1, Item 14) from jacket tube (Figure 1, Item 15) if necessary for replacement.
6. Remove two springs (Figure 1, Item 16) and horn wire (Figure 1, Item 17) from wheel tube (Figure 1, Item 23).

**CAUTION**

Do not strike dowel pins with heavy hammer blows in step 7. Heavy hammer blows may damage bearing in steering gear.

7. Lightly tap out two dowel pins (Figure 1, Item 18) from coupling (Figure 1, Item 19) using 5/16-in. diameter brass rod and hammer.
8. Remove coupling (Figure 1, Item 19) and wheel tube (Figure 1, Item 23) from vehicle. Separate wheel tube and coupling.
9. Remove clamp (Figure 1, Item 20).
10. Remove screw (Figure 1, Item 21) and horn contact assembly (Figure 1, Item 22) from bottom end of wheel tube (Figure 1, Item 23).

**END OF TASK****CLEANING**

1. Clean cover (Figure 1, Item 9), horn contact assembly (Figure 1, Item 13), bushing (Figure 1, Item 14), horn wire (Figure 1, Item 17), and horn contact assembly (Figure 1, Item 22) by wiping with a clean rag.

**WARNING**

- Solvent cleaning compound MIL-PRF-680 Type III is an environmentally compliant and low toxic material. However, it may be irritating to the eyes and skin. Use protective gloves and goggles. Use in well-ventilated areas. Keep away from open flames and other sources of ignition. Failure to do so may result in injury or death to personnel.
- Particles blown by compressed air are hazardous. DO NOT exceed 15 PSI (103 kPa) nozzle pressure when drying parts with compressed air. DO NOT direct compressed air against human skin. Failure to follow this warning may result in injury to personnel. Make sure air stream is directed away from user and other personnel in the area. To prevent injury, user must wear protective goggles or face shield.

2. Clean all other parts with solvent cleaning compound. Dry thoroughly with compressed air.

**END OF TASK**

## INSPECTION

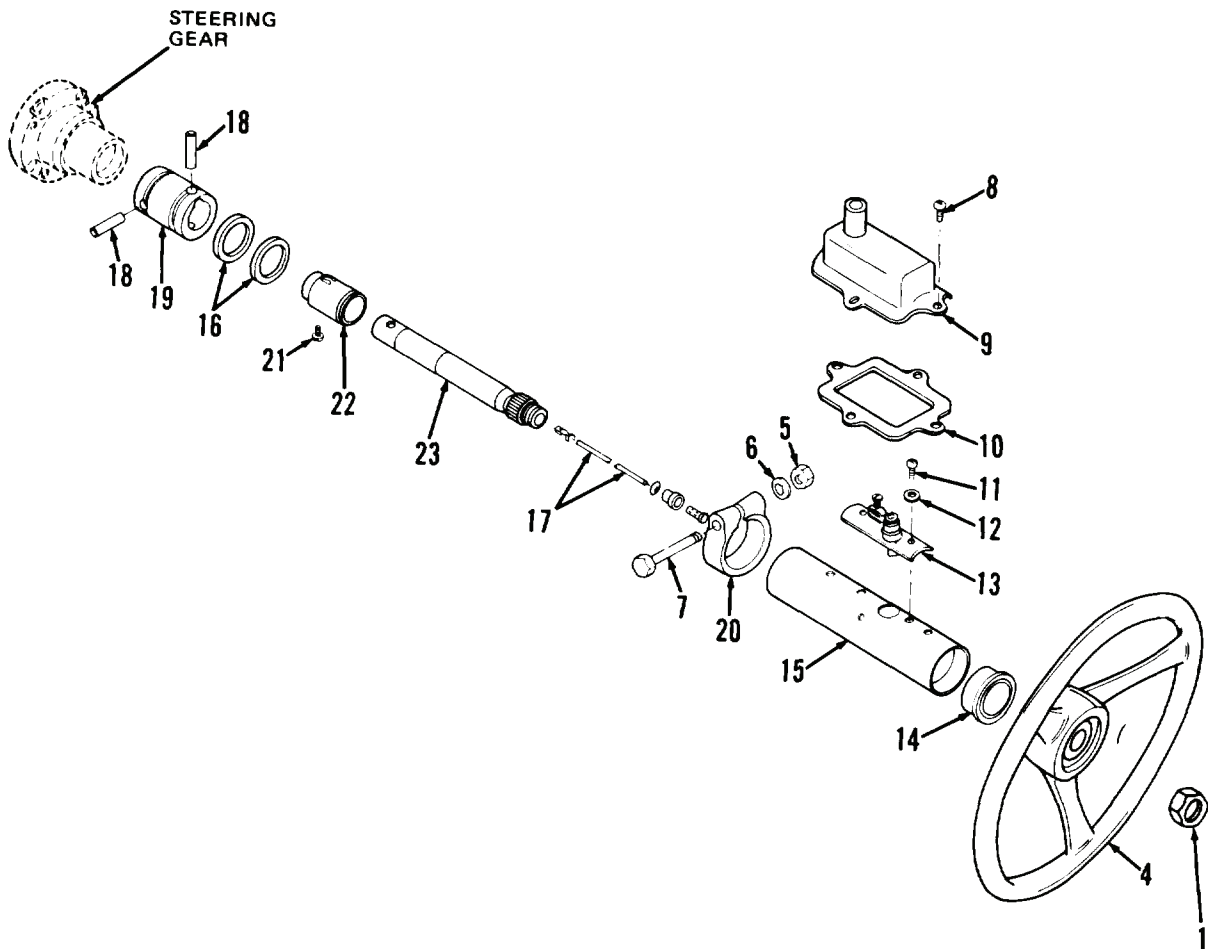

TA127158

**Figure 1. Steering Wheel and Column.**

1. Inspect horn contact assemblies (Figure 1, Items 13 and 22). Replace if cracked, pitted, or scored, or if insulating paper is cracked, torn, or damaged.
2. Inspect retaining springs (Figure 1, Item 16). Replace if cracked or distorted.
3. Inspect coupling (Figure 1, Item 19) and wheel tube (Figure 1, Item 23). Replace if pitted, scored, or worn, or if counterbores for dowel pins (Figure 1, Item 18) elongated. Replace wheel tube (Figure 1, Item 23) if splines are broken or missing, or if threads are damaged.
4. Inspect horn wire (Figure 1, Item 17). Replace if insulation is frayed, or conductor or terminals are broken.
5. Inspect nuts and screws. Replace if worn, or if threads damaged.
6. Inspect all other parts. Replace if cracked, worn, or damaged.

## END OF TASK

**ASSEMBLY**

1. Position clamp (Figure 2, Item 20) on upper cover of steering gear.
2. Position horn contact assembly (Figure 2, Item 22) on wheel tube (Figure 2, Item 23).
3. Install horn wire (Figure 2, Item 17) on wheel tube (Figure 2, Item 23) with screw (Figure 2, Item 21).
4. Position coupling (Figure 2, Item 19) on wheel tube (Figure 2, Item 23), with slot in coupling aligned with terminal on horn contact assembly (Figure 2, Item 22).
5. Install bushing (Figure 2, Item 14) on jacket tube (Figure 2, Item 15), if removed. Use a soft plastic hammer to lightly tap bushing until flush with jacket tube.
6. Position coupling (Figure 2, Item 19) and wheel tube (Figure 2, Item 23) on steering gear input shaft.

**CAUTION**

Do not strike dowel pins with heavy hammer blows in step 7. Heavy hammer blows may damage bearing in steering gear.

7. Install two dowel pins (Figure 2, Item 18) on coupling (Figure 2, Item 19). Lightly tap in using 5/16-in. diameter brass rod and hammer. Be sure dowel pins are centered in coupling.
8. Install two retaining springs (Figure 2, Item 16) in grooves of coupling (Figure 2, Item 19).
9. Apply thin coat of lubriplate to inside of bushing (Figure 2, Item 14).
10. Position jacket tube (Figure 2, Item 15) and bushing (Figure 2, Item 14) over wheel tube (Figure 2, Item 23), through clamp (Figure 2, Item 20), and onto upper cover of steering gear.
11. Install capscrew (Figure 2, Item 7), new lockwasher (Figure 2, Item 6), and nut (Figure 2, Item 5) on clamp (Figure 2, Item 20). Tighten nut to 15 to 20 lb-ft (20 to 27 Nm).
12. Install horn contact assembly (Figure 2, Item 13) on jacket tube (Figure 2, Item 15) with two flat washers (Figure 2, Item 12) and screws (Figure 2, Item 11).
13. Install new seal (Figure 2, Item 10) and cover (Figure 2, Item 9) on jacket tube (Figure 2, Item 15) with four screws (Figure 2, Item 8).

**END OF TASK****INSTALLATION**

1. Route horn wire (Figure 2, Item 17) through center of steering wheel (Figure 2, Item 4) and install steering wheel on splines of wheel tube (Figure 2, Item 23).
2. Install nut (Figure 2, Item 1) on wheel tube (Figure 2, Item 23). Tighten nut to 10 to 15 lb-ft (14 to 20 Nm).
3. Install horn switch (WP 0129).

INSTALLATION - CONTINUED

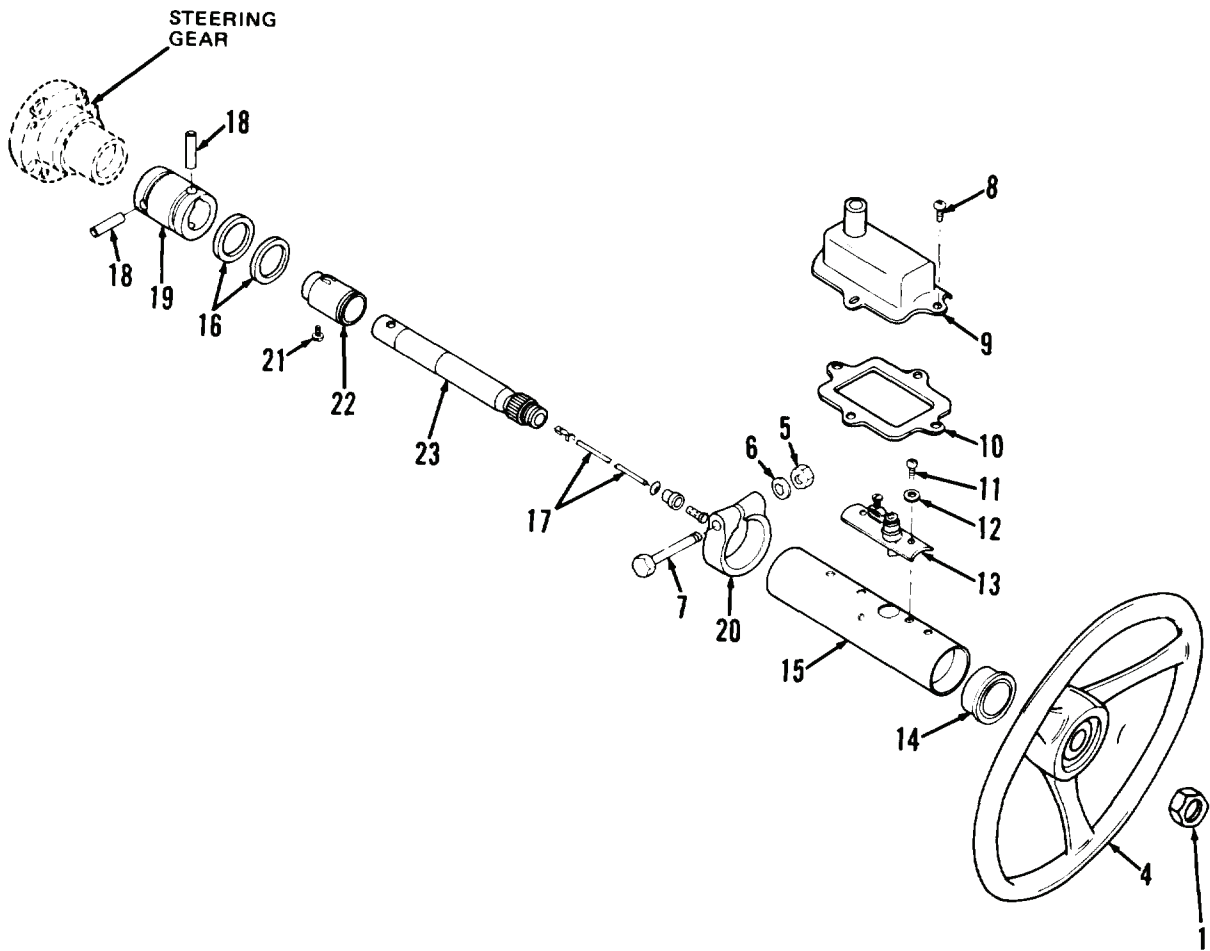

TA127158

Figure 2. Steering Wheel and Column.

END OF TASK

END OF WORK PACKAGE



---

# DIRECT SUPPORT MAINTENANCE INSTRUCTIONS

## STEERING GEAR MAINTENANCE

Removal, Disassembly, Cleaning, Inspection, Repair, Assembly, Installation

---

### INITIAL SETUP

#### Maintenance Level

Direct Support

#### Tools and Special Tools

Tool kit, general mechanic's (Item 15, WP 0309)

Shop equipment, common no. 1 (Item 2, WP 0309)

#### Materials/Parts

Cleaning compound, solvent (Item 10, WP 0310)

Grease, automotive and artillery (Item 17, WP 0310)

Rag, wiping (Item 26, WP 0310)

4 in. worm drive hose clamp

Abrasive cloth, 600 grit

Back-up washer

Cellophane tape

#### Materials/Parts - Continued

Dirt seal

Guide studs (2), 5/16-18 UNC x 3-3/4 in.

Hydraulic fitting

Lockwasher (4)

O-ring (4)

Rotor seal

Seal

#### References

LO 10-3930-638-12

#### Equipment Condition

Vehicle parked on level surface

Engine OFF

Steering wheel and column removed (WP 0257)

Hoses and fittings disconnected from steering gear (WP 0172)

---

## REMOVAL

At center of instrument panel, while supporting steering gear, remove four capscrews, lockwashers, and steering gear from vehicle (Figure 1). Discard lockwashers.

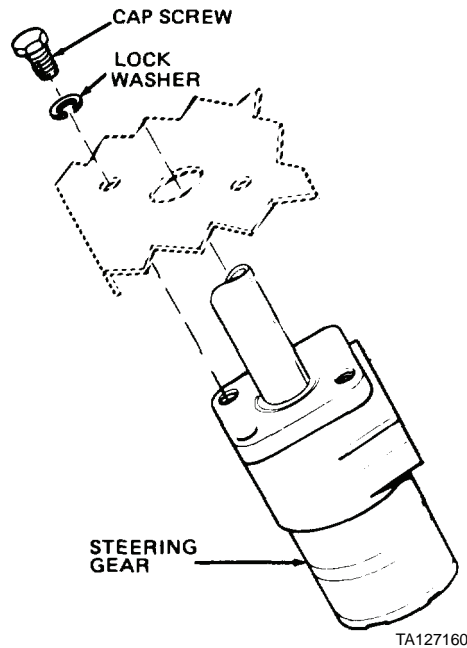

Figure 1. Steering Gear.

## END OF TASK

### DISASSEMBLY

1. Remove dirt seal (Figure 2, Item 1) from steering gear. Discard dirt seal.

### CAUTION

To prevent distortion of steering gear, do not clamp vise jaws directly on steering gear housing.

2. Install a hydraulic fitting, with tube nut or fitting cap attached, into one of four threaded ports in housing (Figure 2, Item 43). Clamp fitting in vise so end cover (Figure 2, Item 3) faces upward.
3. Remove seven hex bolts (Figure 2, Item 2) from end cover (Figure 2, Item 3).

### CAUTION

Do not attempt to remove guide pin from inside center of end cover. Guide pin is press fit in the end cover and is not serviceable separately.

4. Loosen end cover (Figure 2, Item 3) by tapping with a soft hammer. Remove end cover, washer (Figure 2, Item 6), and commutator (Figure 2, Item 7) from rotor seal (Figure 2, Item 4) and seal retainer (Figure 2, Item 5).
5. Loosen seal retainer (Figure 2, Item 5) by tapping sideways with a soft hammer. Remove seal retainer from housing (Figure 2, Item 43). Discard seal (Figure 2, Item 4).
6. Remove commutator ring (Figure 2, Item 8), with a lifting and sliding motion, from manifold (Figure 2, Item 9).
7. Remove manifold (Figure 2, Item 9), with a lifting and sliding motion, from rotor set (Figure 2, Item 11).



DISASSEMBLY - CONTINUED

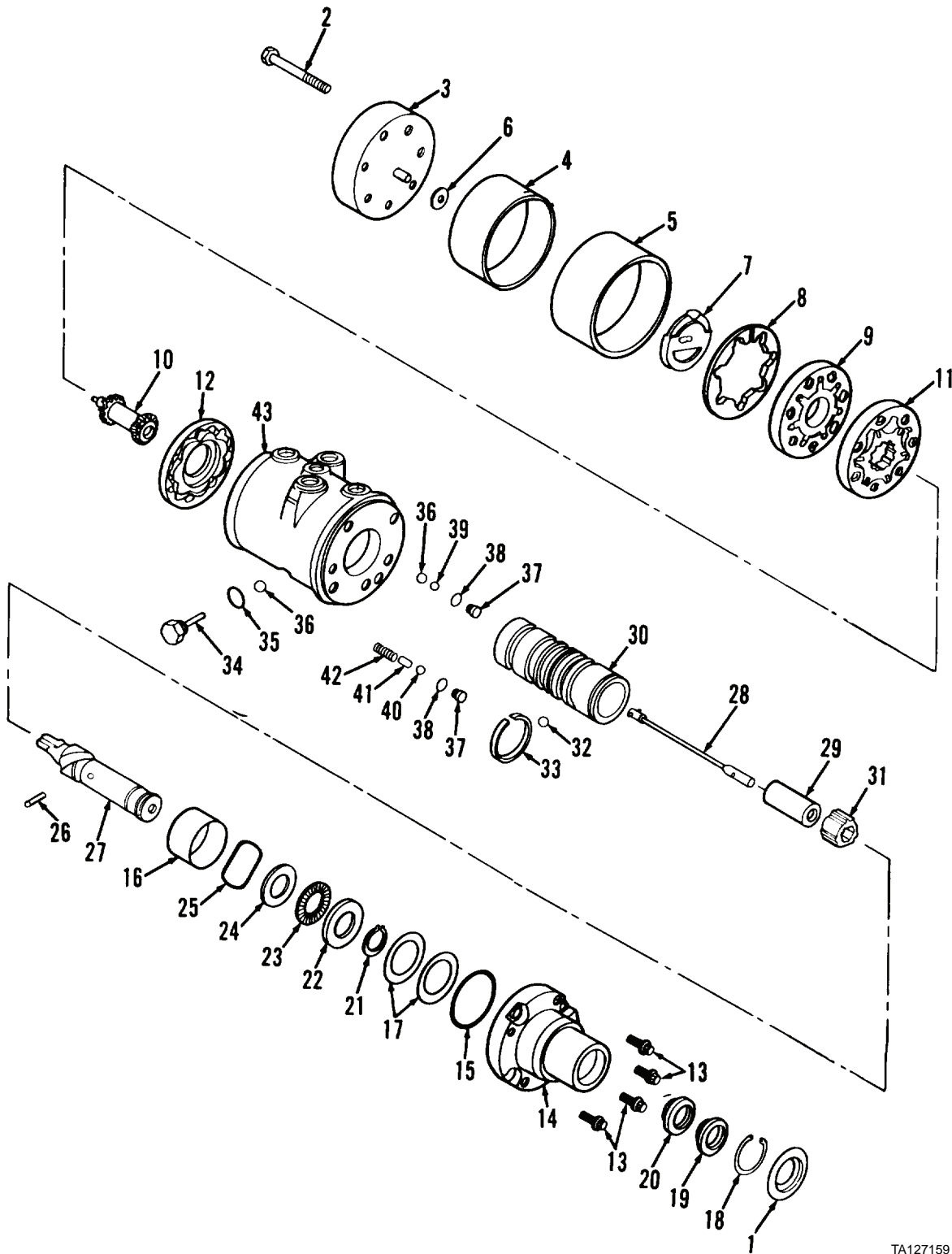

TA127159

Figure 2. Steering Gear Components.

**DISASSEMBLY - CONTINUED****CAUTION**

Handle the rotor set carefully to avoid nicks and scratches. Apply some hand pressure to rotor by grasping rotor and pressing into contact with the stator (Figure 3).

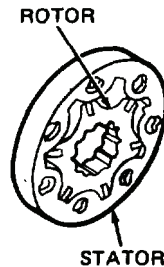

**Figure 3. Rotor Set.**

8. Remove rotor set (Figure 4, Item 11), spacer (Figure 4, Item 12), and drive link (Figure 4, Item 10) as an assembly by grasping spacer and removing assembly with a sliding and lifting motion.
9. Remove drive link (Figure 4, Item 10) from rotor set (Figure 4, Item 11). Slide rotor set on spacer (Figure 4, Item 12), allowing drive link teeth to clear hole in spacer.
10. Carefully place rotor set (Figure 4, Item 11) aside.

**CAUTION**

To prevent distortion of steering gear, do not clamp vise jaws directly on steering gear housing.

11. Change position of housing (Figure 4, Item 43) so input shaft (Figure 4, Item 27) faces upward.
12. Using a center punch and hammer, make match marks on upper cover (Figure 4, Item 14) and housing (Figure 4, Item 43).
13. Using a 5/16-in. 12-point socket, remove four capscrews (Figure 4, Item 13).

**CAUTION**

Do not use excessive force to remove spool from housing. Avoid applying side forces to input shaft which would cause binding of spool.

14. Remove upper cover (Figure 4, Item 14), input shaft (Figure 4, Item 27), and spool (Figure 4, Item 30), as an assembly, by grasping input shaft and removing assembly with a smooth, upward motion.
15. Remove O-ring (Figure 4, Item 15) from upper cover (Figure 4, Item 14). Discard O-ring.
16. Remove input shaft (Figure 4, Item 27), shims (Figure 4, Item 17), and spacer (Figure 4, Item 16) from upper cover (Figure 4, Item 14).
17. Remove retaining ring (Figure 4, Item 18), back-up washer (Figure 4, Item 19), and seal (Figure 4, Item 20) from upper cover (Figure 4, Item 14). Discard seal.
18. At input shaft (Figure 4, Item 27), remove retaining ring (Figure 4, Item 21), thrust washers (Figure 4, Items 22 and 24), bearing (Figure 4, Item 23), and spring washer (Figure 4, Item 25).
19. Remove needle roller (Figure 4, Item 26) from input shaft (Figure 4, Item 27) by tapping out with 0.120 in. (3.05 mm) pin punch and hammer.
20. Invert spool (Figure 4, Item 30) and remove torsion bar (Figure 4, Item 28) and spacer (Figure 4, Item 29).

DISASSEMBLY - CONTINUED

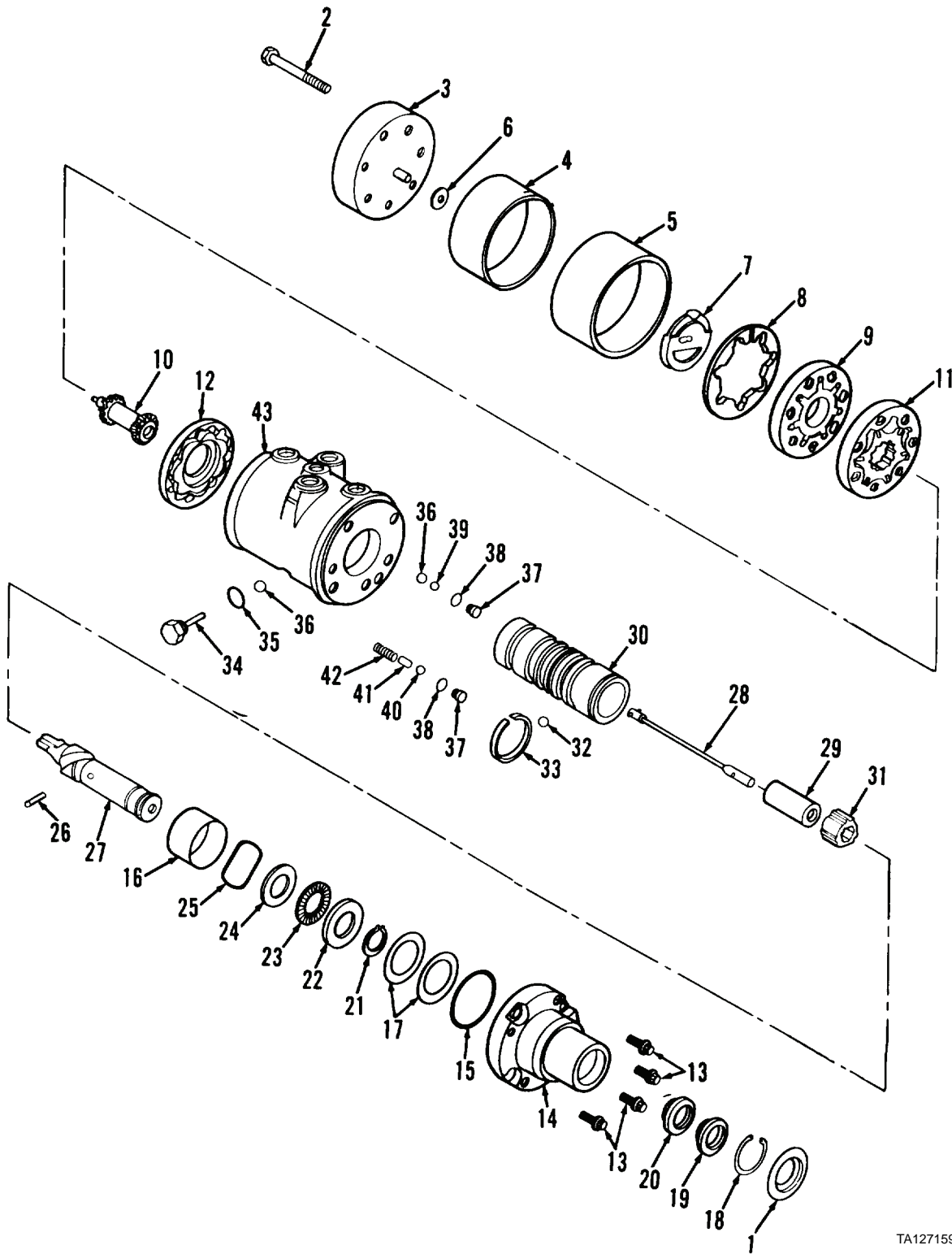

TA127159

Figure 4. Steering Gear Components.

**DISASSEMBLY - CONTINUED****NOTE**

Do not attempt to remove pin from end of torsion bar. Pin is press fit in torsion bar and is not serviceable separately.

21. Remove drive ring (Figure 5, Item 31) from spool (Figure 5, Item 30) by placing end of spool on a table surface and rotating input (Figure 5, Item 27) shaft to extremes of travel until drive ring falls free.
22. With end of spool (Figure 5, Item 30) on stable surface, rotate input shaft (Figure 5, Item 27) clockwise until actuator ball (Figure 5, Item 32) disengages from helical groove in input shaft. Carefully lift out input shaft and catch actuator ball.

**NOTE**

Remove retainer spring only if required for replacement.

23. Remove retainer spring (Figure 5, Item 33) from spool (Figure 5, Item 30) by grasping flattened end of retainer spring with pliers. Carefully pry flattened end over shoulder on spool with pliers and a screwdriver. Continue pulling motion to remove retainer spring while avoiding scratching spool.

**NOTE**

In steps 24 and 25, exercise care to prevent loss of small parts. If necessary, shake housing to remove balls.

24. Remove plug (Figure 5, Item 34), O-ring (Figure 5, Item 35), and ball (Figure 5, Item 36) from housing (Figure 5, Item 43). Discard O-ring.
25. Remove two plugs (Figure 5, Item 37), O-rings (Figure 5, Item 38), three balls (Figure 5, Items 39, 36, and 40), needle roller (Figure 5, Item 41), and spring (Figure 5, Item 42). Discard O-rings.

**END OF TASK****CLEANING****WARNING**

- Solvent cleaning compound MIL-PRF-680 Type III is an environmentally compliant and low toxic material. However, it may be irritating to the eyes and skin. Use protective gloves and goggles. Use in well-ventilated areas. Keep away from open flames and other sources of ignition. Failure to do so may result in injury or death to personnel.
- Particles blown by compressed air are hazardous. DO NOT exceed 15 PSI (103 kPa) nozzle pressure when drying parts with compressed air. DO NOT direct compressed air against human skin. Make sure air stream is directed away from user and other personnel in the area. To prevent injury, user must wear protective goggles or face shield. Failure to follow this warning may result in injury to personnel.

**NOTE**

Do not use rags to dry internal parts.

Clean all parts with solvent cleaning compound. Dry thoroughly with compressed air.

CLEANING - CONTINUED

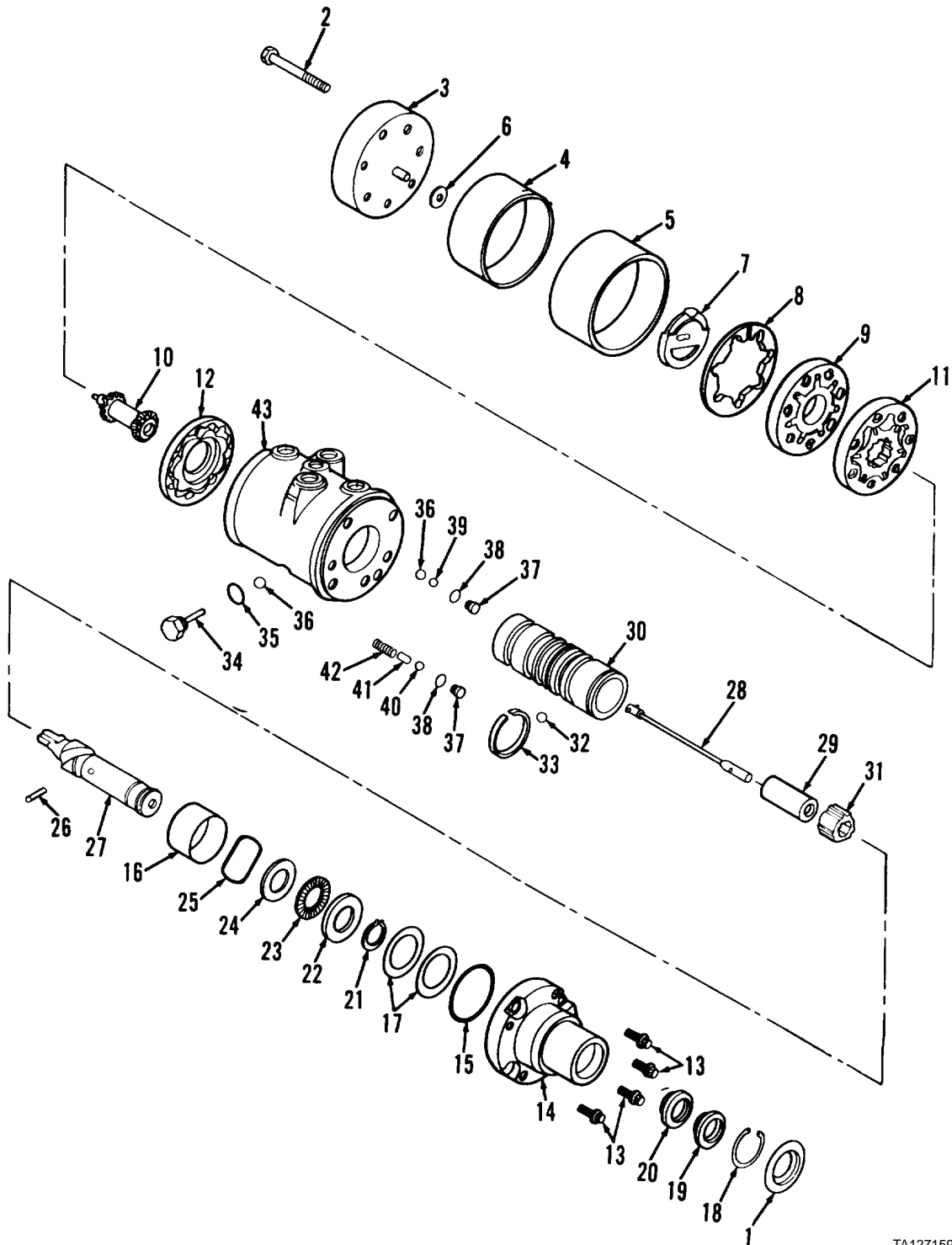

TA127159

Figure 5. Steering Gear Components.

END OF TASK

**INSPECTION**

1. Inspect spring washer (Figure 6). Replace if thickness is less than 0.140 in. (3.56 mm) as shown, or cracked or distorted.

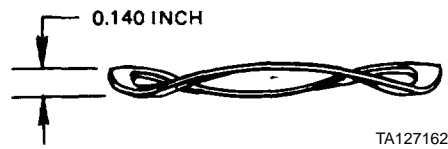

**Figure 6. Spring Washer.**

2. Inspect spring (Figure 7, Item 42). Install in spring tester. Ensure force to compress spring to 0.830 in. (21.08 mm) is 12.5 to 14.5 lb (5.67 to 6.58 kg). Replace spring if force is not 12.5 to 14.5 lb (5.67 to 6.58 kg).
3. Inspect torsion bar (Figure 7, Item 28) and pin. Use a micrometer to measure diameter of pin on both sides. Diameter must not vary more than 0.001 in. (0.03 mm). Replace torsion bar if scored, bent, or worn, or if pin diameter varies more than 0.001 in. (0.03 mm).
4. Inspect thrust washers (Figure 7, Items 22 and 24), thrust bearing (Figure 7, Item 23), and wear washer (Figure 7, Item 6). Replace if pitted, scored, or excessively worn.

**NOTE**

Light polishing of shaft due to seal contact is normal and is not cause for shaft replacement.

5. Inspect input shaft (Figure 7, Item 27). Replace if cracked or bent, if seal area is pitted, corroded, or worn, or if helical groove is chipped or pitted.
6. Inspect needle roller (Figure 7, Item 26). Replace if cracked or damaged.
7. Inspect balls (Figure 7, Items 32, 36, 39, and 40). Replace if pitted, scored, out-of-round, or damaged.
8. Inspect retaining rings (Figure 7, Items 18 and 21) and spring (Figure 7, Item 33). Replace if cracked or broken.
9. Inspect screws (Figure 7, Items 2 and 13) and plugs (Figure 7, Items 34 and 37). Replace if worn, or if threads are damaged.
10. Inspect drive link (Figure 7, Item 10). Replace if cracked, or if teeth are chipped, broken, or excessively worn.

**NOTE**

Spool is not serviced separately. Replace steering gear assembly if spool is defective.

11. Inspect spool (Figure 7, Item 30). Replace steering gear assembly if splines are chipped or broken, or if outside diameter or control edges are scored, worn, or damaged.
12. Inspect end cover (Figure 7, Item 3). Replace if pin is damaged, or if lapped face is nicked, burred, or scored.
13. Inspect upper cover (Figure 7, Item 14). Replace if cracked or broken, or if end is nicked or burred.
14. Inspect drive ring (Figure 7, Item 31). Replace if splines are chipped or damaged.

**NOTE**

Housing is not serviced separately. Replace steering gear assembly if housing is defective.

15. Inspect housing (Figure 7, Item 43). Replace steering gear assembly if threads are damaged, or if bore or ends are nicked, burred, or scored.

INSPECTION - CONTINUED

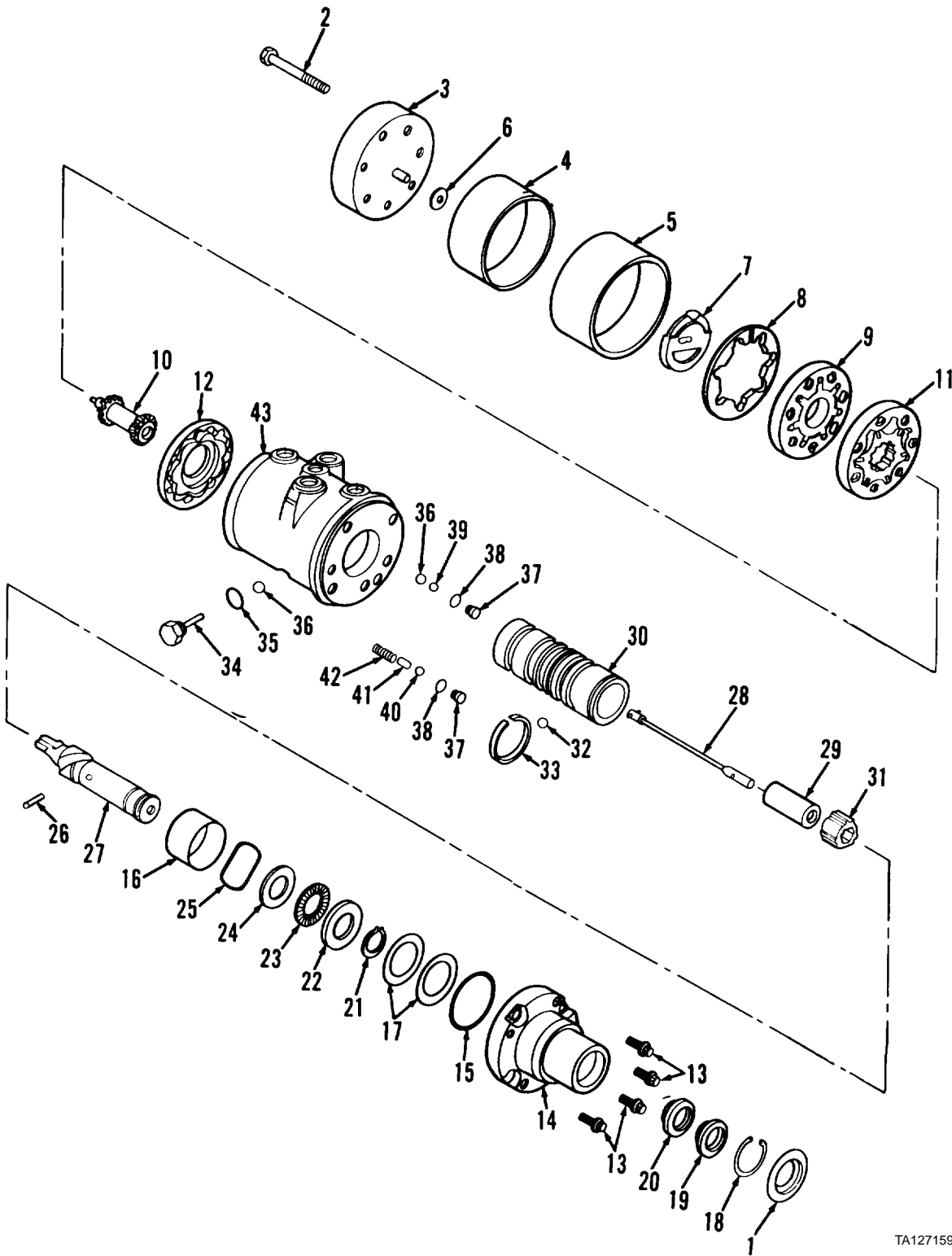

TA127159

Figure 7. Steering Gear Components.

**INSPECTION - CONTINUED****NOTE**

Replace commutator and commutator ring as a matched set. Commutator and ring are not serviced separately.

16. Inspect commutator (Figure 8, Item 7) and commutator ring (Figure 8, Item 8). Measure side clearance between commutator and ring. Replace commutator and ring if either is scored, pitted, or burred, or if side clearance is more than 0.0015 in. (0.038 mm).
17. Inspect manifold (Figure 8, Item 9) and spacer (Figure 8, Item 12). Replace if nicked, burred, or scored.
18. Inspect rotor set (Figure 8, Item 11). Check lobes and faces of rotor and stator for scratches, burrs, and scoring. Inspect splines in rotor for chipping, damage, or excessive wear. Use micrometer to measure thickness (face-to-face) of rotor and stator. Replace rotor set if lobes, faces, or splines are damaged, or if thickness difference between rotor and stator is more than 0.002 in. (0.05 mm).
19. Inspect rotor set (Figure 8, Item 11). Place rotor set face down on lapped face of end cover (Figure 8, Item 3). Use a tapered feeler gage to measure clearance between rotor and stator at each lobe. Replace rotor set if clearance is more than 0.007 in. (0.18 mm).

**END OF TASK****REPAIR****WARNING**

- Solvent cleaning compound MIL-PRF-680 Type III is an environmentally compliant and low toxic material. However, it may be irritating to the eyes and skin. Use protective gloves and goggles. Use in well-ventilated areas. Keep away from open flames and other sources of ignition. Failure to do so may result in injury or death to personnel.
- Particles blown by compressed air are hazardous. DO NOT exceed 15 PSI (103 kPa) nozzle pressure when drying parts with compressed air. DO NOT direct compressed air against human skin. Make sure air stream is directed away from user and other personnel in the area. To prevent injury, user must wear protective goggles or face shield. Failure to follow this warning may result in injury to personnel.

**NOTE**

If abrasive cloth is new, it should be rubbed with a piece of steel to remove any sharp grit which would produce scratches.



REPAIR - CONTINUED

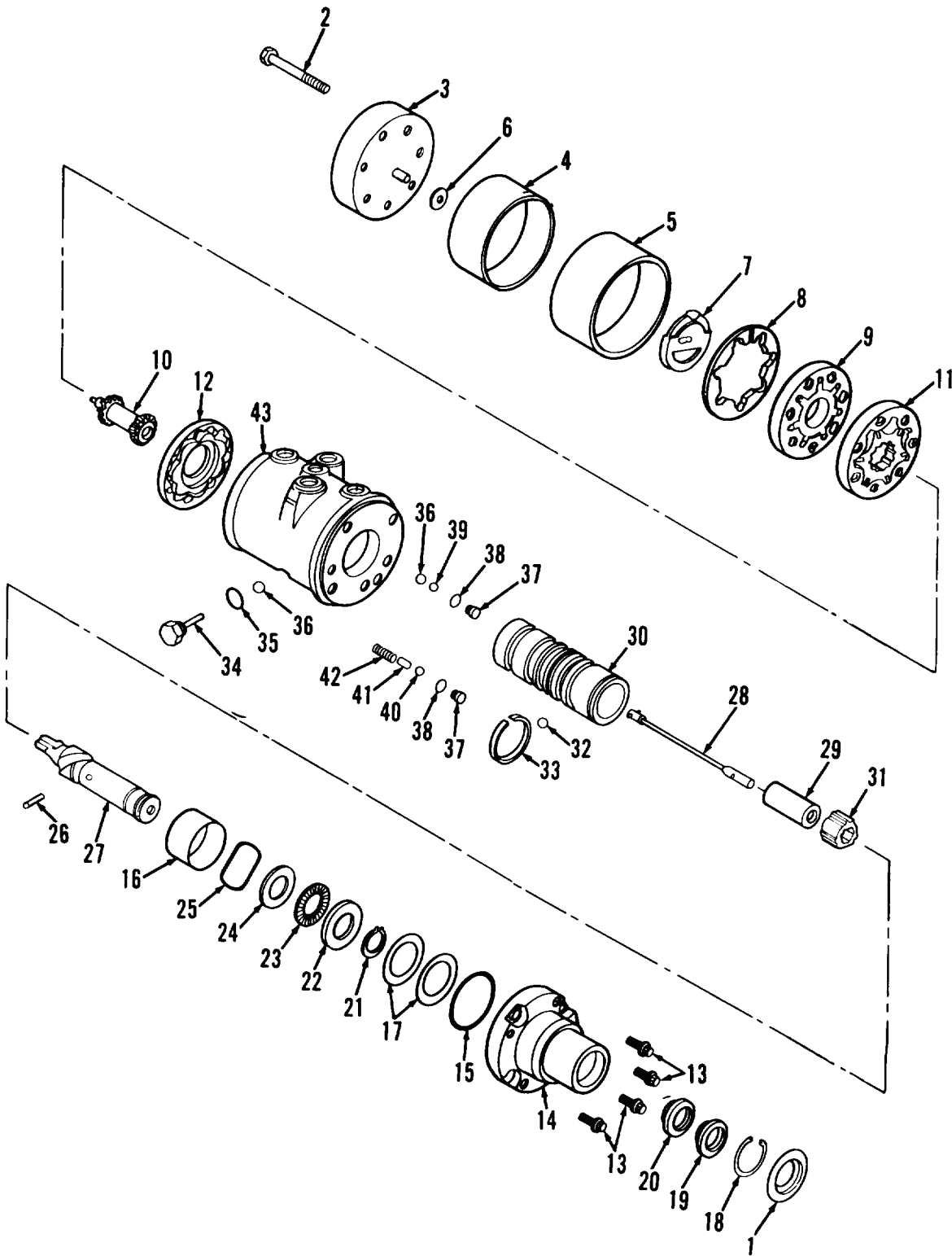
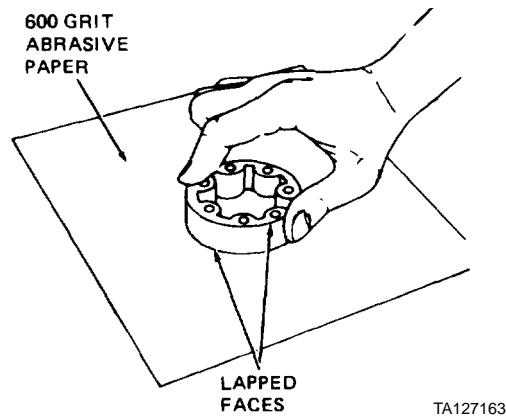

Figure 8. Steering Gear Components.

**REPAIR - CONTINUED**

Lap and clean upper cover (Figure 10, Item 14), housing (Figure 10, Item 43), commutator ring (Figure 10, Item 8), manifold (Figure 10, Item 9), and spacer (Figure 10, Item 12). Place 600-grit abrasive cloth on an extremely flat surface. Hold each part so contact with abrasive cloth is flat as possible, and lightly stroke 6 to 10 times across paper as shown (Figure 9). Check lapped face of each part for small bright areas which cannot be cleaned up. After lapped surfaces are clean, wash parts with solvent cleaning compound and dry thoroughly with compressed air.



**Figure 9. Lapping Manifold.**

**END OF TASK****ASSEMBLY****NOTE**

Do not lubricate parts unless instructed to do so.

1. Position spring (Figure 10, Item 42), needle roller (Figure 10, Item 41), and ball (Figure 10, Item 40) in cavity of housing (Figure 10, Item 43).
2. Install new O-ring (Figure 10, Item 38) and plug (Figure 10, Item 37) in housing (Figure 10, Item 43).
3. Position two balls (Figure 10, Items 36 and 39) in cavity of housing (Figure 10, Item 43).
4. Install new O-ring (Figure 10, Item 38) and plug (Figure 10, Item 37) in housing (Figure 10, Item 43).
5. Install ball (Figure 10, Item 36), new O-ring (Figure 10, Item 35), and plug (Figure 10, Item 34) in side of housing (Figure 10, Item 43). Tighten plug to 10 to 14 lb-ft (14 to 19 Nm).
6. Position thrust washers (Figure 10, Items 22 and 24) and thrust bearing (Figure 10, Item 23) on input shaft (Figure 10, Item 27).
7. Install retaining ring (Figure 10, Item 21) on input shaft (Figure 10, Item 27).

**NOTE**

Perform step 8 only if retainer spring has been removed.

8. Install new retainer spring (Figure 10, Item 33). Carefully insert spring into groove on spool (Figure 10, Item 30) to avoid scratching or nicking spool.
9. Position spring washer (Figure 10, Item 25) over thrust washer (Figure 10, Item 24) and thrust bearing (Figure 10, Item 23).
10. Position actuator ball (Figure 10, Item 32) in ball seat located inside spool (Figure 10, Item 30).
11. Install input shaft (Figure 10, Item 27) in spool (Figure 10, Item 30). Hold input shaft and spool in a horizontal position. Insert input shaft into spool, engaging helix and actuator ball with a counterclockwise motion.

ASSEMBLY - CONTINUED

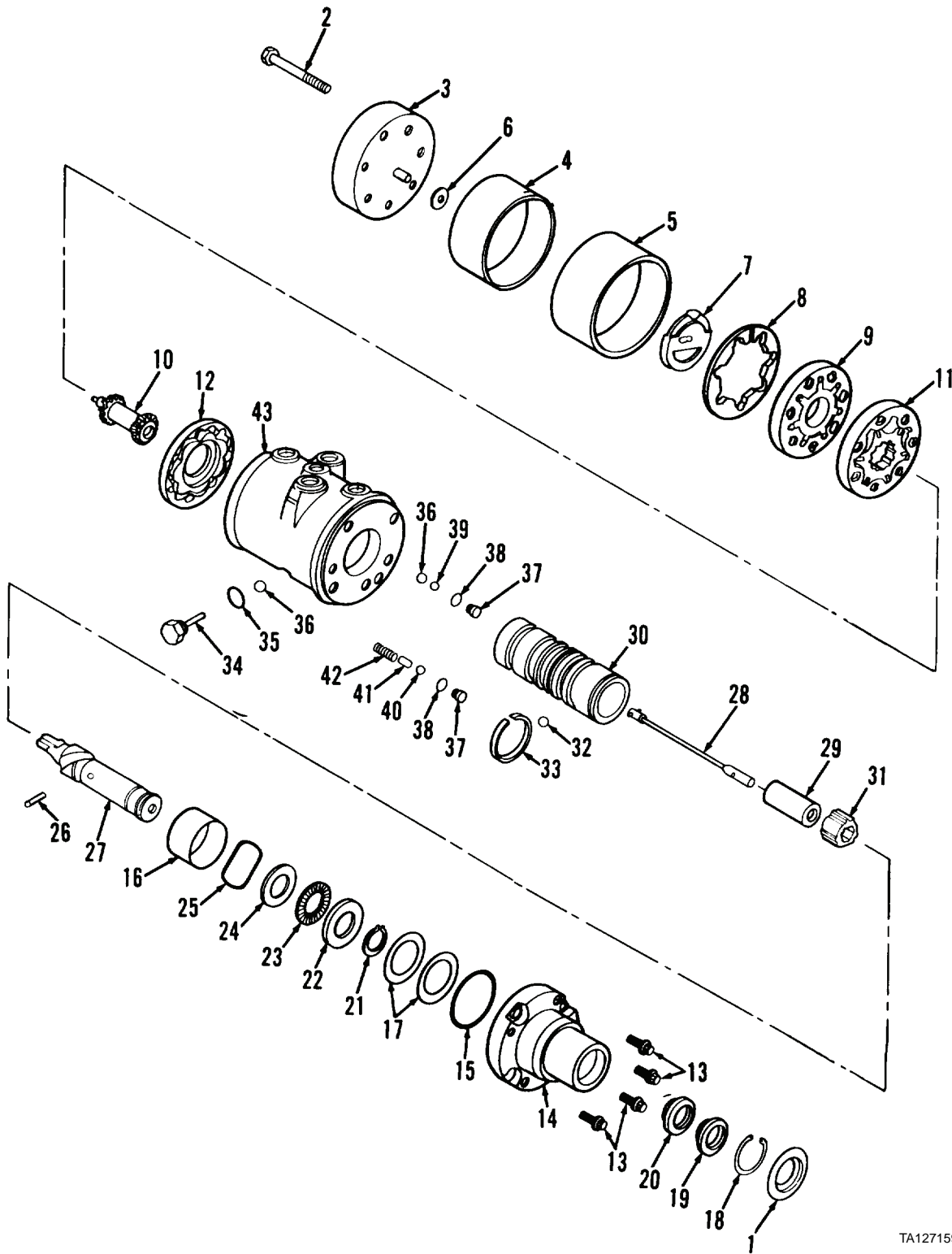

TA127159

Figure 10. Steering Gear Components.

**ASSEMBLY - CONTINUED**

12. Position torsion bar (Figure 12, Item 28) in spool (Figure 12, Item 30). Use mid-section of torsion bar as a gage, and insert torsion bar between spool end and thrust washer (Figure 12, Item 24) as shown (Figure 11).

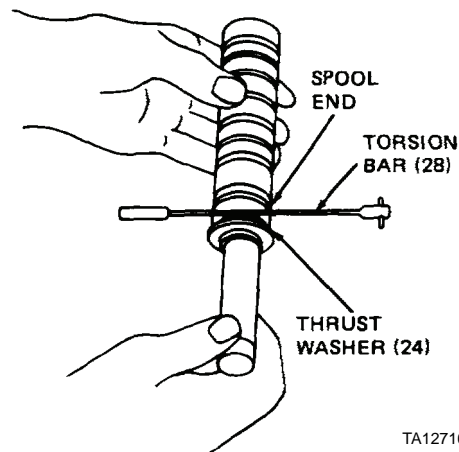

**Figure 11. Using Torsion Bar as Gage.**

13. Position input shaft (Figure 12, Item 27) and spool vertically. Keeping torsion bar between spool end and thrust washer, place shaft and spool in a vertical position, with shaft end on a table surface.
14. Install drive ring (Figure 12, Item 31). Position drive ring in end of spool (Figure 12, Item 30). Visually align an internal space on drive ring with a tooth on input shaft (Figure 12, Item 27) spline, and allow drive ring to drop to limit of its travel. Rotate input shaft slightly to allow drive ring to fully engage.
15. Remove torsion bar (Figure 12, Item 28).

**NOTE**

If new torsion bar is used, check color code on pin end of torsion bar. Do not install unless torsion bar is color coded orange.

16. Install torsion bar (Figure 12, Item 28) and spacer (Figure 12, Item 29). Slide spacer over cross-hole end of torsion bar (Figure 12, Item 28). Then, insert torsion bar cross-hole end into end of spool (Figure 12, Item 30).
17. Position torsion bar (Figure 12, Item 28) to align cross-hole with cross-hole in input shaft. Insert a 0.120-in. diameter pin punch into cross-holes to maintain alignment.
18. Install needle roller (Figure 12, Item 26) into cross-hole in input shaft while withdrawing pin punch. Remove pin punch when needle roller engages cross-hole in torsion bar (Figure 12, Item 28). Place cross-hole of input shaft (Figure 12, Item 27) over drive hole of a 1/2-in. drive socket. Using a hammer and 0.120-in. (3.05-mm) diameter pin punch, lightly tap needle roller to approximately 1/32-in. (0.79 mm) below outside diameter of input shaft.

**CAUTION**

To prevent distortion of steering gear, do not clamp vise jaws directly on steering gear housing.

19. Position and clamp housing (Figure 12, Item 43). Install O-ring tube fitting, with tube nut or fitting cap attached, into one of four threaded ports in housing. Clamp O-ring fitting in vise so upper cover (Figure 12, Item 3) end of housing faces upward.
20. Position spacer (Figure 12, Item 16) over spool (Figure 12, Item 30).

ASSEMBLY - CONTINUED

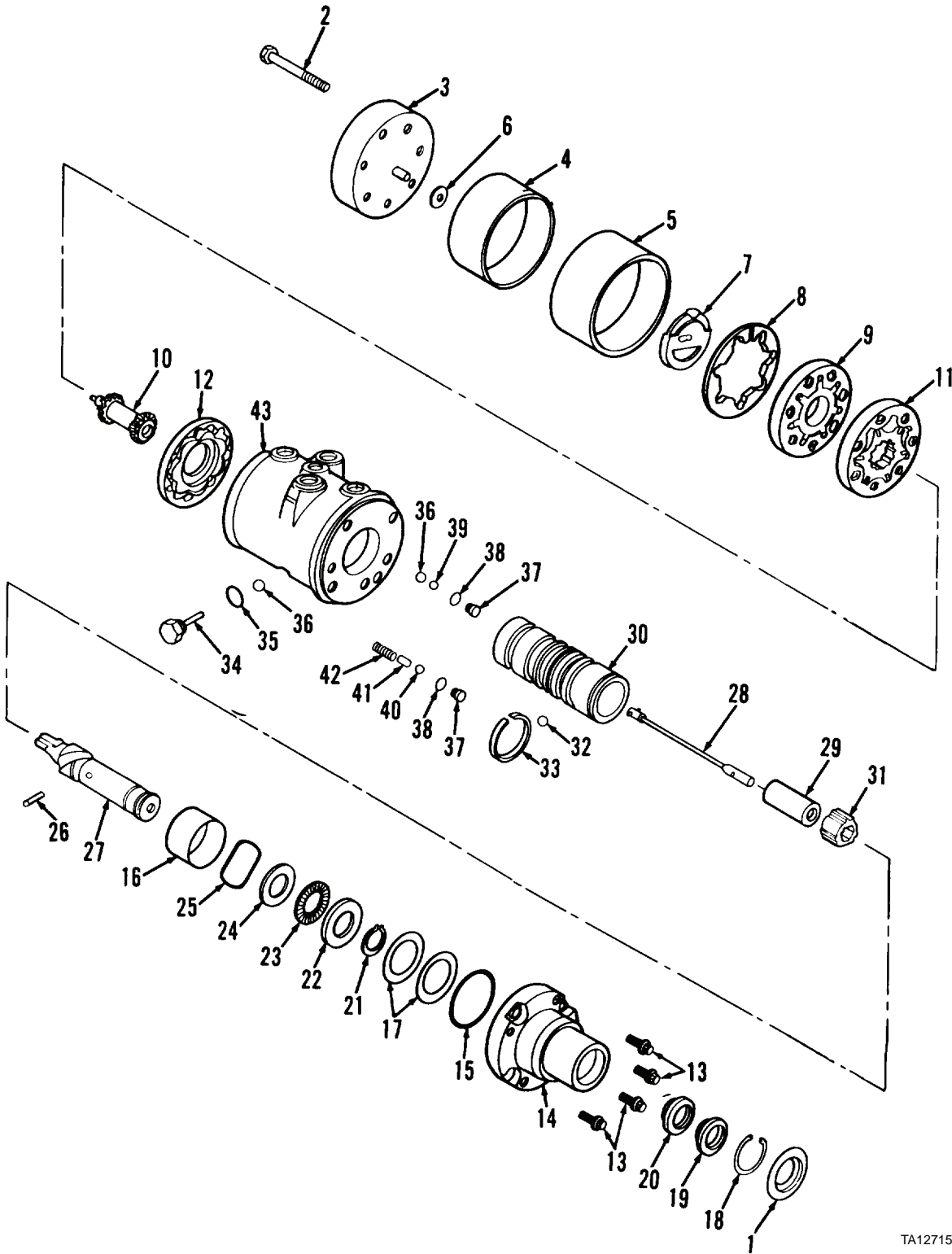

TA127159

Figure 12. Steering Gear Components.

**ASSEMBLY - CONTINUED****CAUTION**

In step 21, avoid applying side forces to the spool which would cause binding and damage.

21. Install spool (Figure 13, Item 30) with input shaft (Figure 13, Item 27) into end bore of housing (Figure 13, Item 43).

**NOTE**

Use original shims unless cracked or damaged. Replace a defective shim with shim of equal thickness.

22. Position shims (Figure 13, Item 17) on top of thrust washer (Figure 13, Item 22).
23. Apply coat of grease to new O-ring (Figure 13, Item 15) and install in counterbore of upper cover (Figure 13, Item 14).

**NOTE**

If original upper cover is used, align match marks on upper cover and housing. If a new upper cover is used, disregard match mark on housing.

24. Install upper cover (Figure 13, Item 14) over input shaft (Figure 13, Item 27) and onto housing (Figure 13, Item 43).
25. Install four capscrews (13) on upper cover (14). Hand tighten capscrews.
26. Position worm type hose clamp around flange of upper cover (Figure 13, Item 14) and outside diameter of housing (Figure 13, Item 43). Tighten clamp to align upper cover and housing.
27. Alternately tighten four capscrews (Figure 13, Item 13) to 18 to 22 lb-ft (24 to 30 Nm).

**CAUTION**

To prevent distortion of steering gear, do not clamp vise jaws directly on steering gear housing.

28. Reposition housing (Figure 13, Item 43) and clamp. Clamp fitting in vise so input shaft (Figure 13, Item 27) faces downward.
29. Install drive link (Figure 13, Item 10). Pull input shaft (Figure 13, Item 27) downward and prevent rotation. Engage splines on drive link in spool (Figure 13, Item 30), and rotate drive link to position spool end flush with end of housing (Figure 13, Item 43). Remove drive link, reposition to allow drive link slot to engage pin on torsion bar, and insert drive link.

**NOTE**

Perform steps 30 through 34 only if input shaft and/or upper cover have been replaced.

30. Measure protrusion of spool (Figure 13, Item 30) by pulling input shaft (Figure 13, Item 27) downward. Measure relationship of spool end to end of housing using feeler gage. (Measure from end nearest outside diameter of spool to end nearest inside diameter of spool to end nearest inside diameter of body.) If spool end is within 0.0025 in. (0.064 mm) of being flush, proceed to step 33. If not within 0.0025 in. (0.064 mm) of being flush, proceed to step 31.
31. Remove drive link (Figure 13, Item 10).
32. Change position of housing (Figure 13, Item 43) by clamping fitting in vise so input shaft (Figure 13, Item 27) faces upward.
33. Remove four capscrews (Figure 13, Item 13) and upper cover (Figure 13, Item 14).
34. Add or remove shims (Figure 13, Item 17) to satisfy specifications in step 30 and repeat steps 31 through 34 until spool is flush with end of housing within 0.0025 in. (0.064 mm).
35. Install two 5/16-18 UNC x 3-3/4 in. guide studs in two of seven threaded holes at end of housing (Figure 13, Item 43).
36. Install spacer (Figure 13, Item 12) by positioning plain side of spacer away from housing (Figure 13, Item 43), and lowering spacer over guide studs and onto housing.

ASSEMBLY - CONTINUED

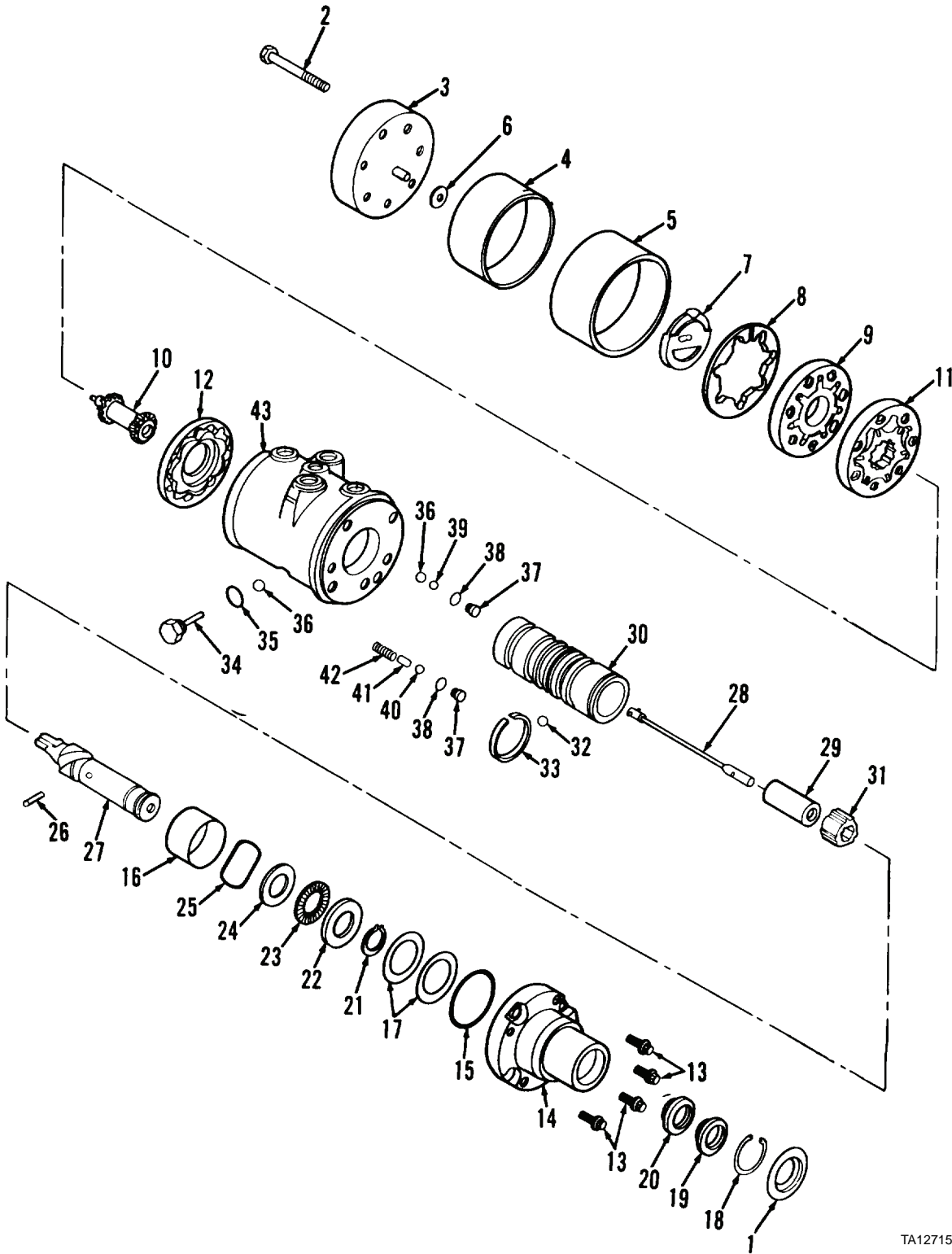

TA127159

Figure 13. Steering Gear Components.

**ASSEMBLY - CONTINUED****NOTE**

One of the seven holes in the stator of the rotor set is smaller than the other six holes. In step 37, position this smaller hole over one of the guide studs.

37. Install rotor set (Figure 15, Item 11) by lowering rotor set over guide studs and onto spacer (Figure 15, Item 12).
38. Install manifold (Figure 15, Item 9) by positioning circular slot side of manifold away from housing (Figure 15, Item 43) and lowering manifold over guide studs and onto rotor set (Figure 15, Item 11).
39. Position slot side of commutator ring (Figure 15, Item 8) toward housing (Figure 15, Item 43), and lower over guide studs and onto manifold (Figure 15, Item 9).
40. Install seal retainer (Figure 15, Item 5) and new rotor seal (Figure 15, Item 4) over rotor set (Figure 15, Item 11) and down against housing (Figure 15, Item 43).
41. Install commutator (Figure 15, Item 7) by positioning counterbore side of commutator away from housing (Figure 15, Item 43), and engaging slotted hole in commutator with nose of drive link (Figure 15, Item 10). Center commutator in commutator ring (Figure 15, Item 8) to achieve equal spacing as shown (Figure 14).

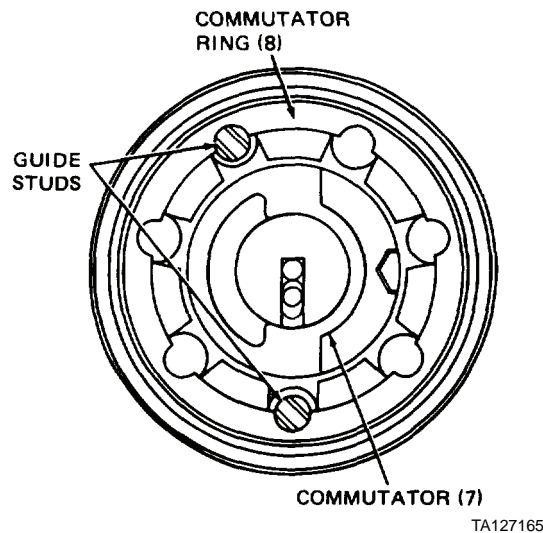
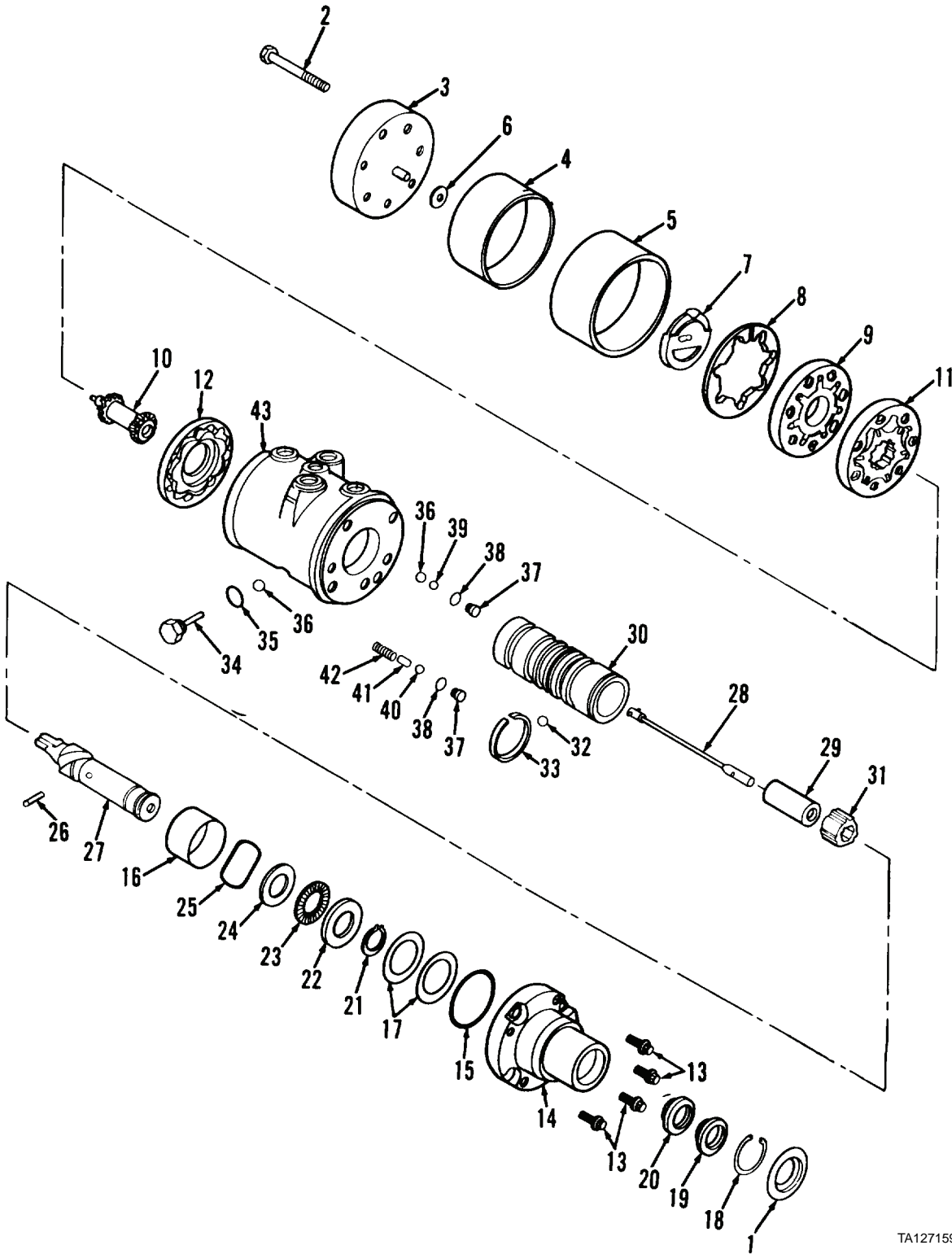

**Figure 14. Installing Commutator.**

42. Apply a small amount of grease to one side of wear washer (Figure 15, Item 6) and place wear washer over pin on end cover (Figure 15, Item 3). Grease should hold washer in place when end cover is inverted.
43. Install end cover (Figure 15, Item 3) with wear washer (Figure 15, Item 6) over guide studs and onto commutator ring (Figure 15, Item 8).
44. Install five hex bolts (Figure 15, Item 2) on end cover (Figure 15, Item 3). Hand-tighten bolts.
45. Remove two guide studs from housing (Figure 15, Item 43).
46. Install two remaining hex bolts (Figure 15, Item 2). Hand-tighten bolts.



ASSEMBLY - CONTINUED



TA127159

Figure 15. Steering Gear Components.

**ASSEMBLY - CONTINUED****CAUTION**

Tighten seven hex bolts according to steps 47 and 48 only. To avoid damage to steering gear, do not overtighten bolts.

47. Using 5/16 in., 12-point socket, tighten seven hex bolts in sequence shown (Figure 16) to initial torque of 2 to 3 lb-ft (2.7 to 4 Nm).

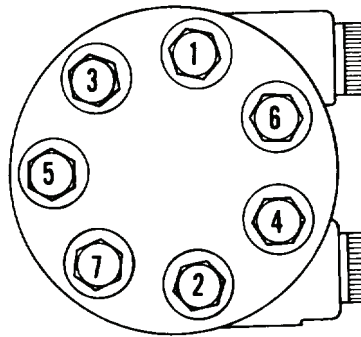

TA127166

**Figure 16. Bolt Tightening Sequence.**

48. Using same sequence, tighten seven hex bolts (Figure 17, Item 2) to 15 to 19 lb-ft (20 to 26 Nm) final torque.  
49. Change position of housing (Figure 17, Item 43) by clamping fitting in vise so input shaft faces upward.

**NOTE**

Cover end of input shaft with cellophane tape to protect new seal from sharp edges of shaft.

50. Apply coat of grease to new seal (Figure 17, Item 20) and install seal over input shaft (Figure 17, Item 27) lip side first.  
51. Install new back-up washer (Figure 17, Item 19) over input shaft (Figure 17, Item 27) with small end toward input shaft. Then, slide back-up washer onto input shaft and against seal (Figure 17, Item 20). Using a 7/8-in. deep well socket, gently push back-up washer and seal down into upper cover (Figure 17, Item 14).  
52. Install retaining ring (Figure 17, Item 18) by positioning rounded edge of retaining ring toward upper cover (Figure 17, Item 14). Slide retaining ring over input shaft, and install in groove in upper cover using snap ring pliers.  
53. Install new dirt seal (Figure 17, Item 1) in counterbore of upper cover (Figure 17, Item 14).  
54. Remove hydraulic fitting from port of housing (Figure 17, Item 43).

**NOTE**

If steering gear is to be stored, plug two cylinder ports and fill inlet port with clean hydraulic oil (LO 10-3930-638-12). Rotate input shaft until hydraulic oil appears at outlet port, and plug inlet and outlet port.

ASSEMBLY - CONTINUED

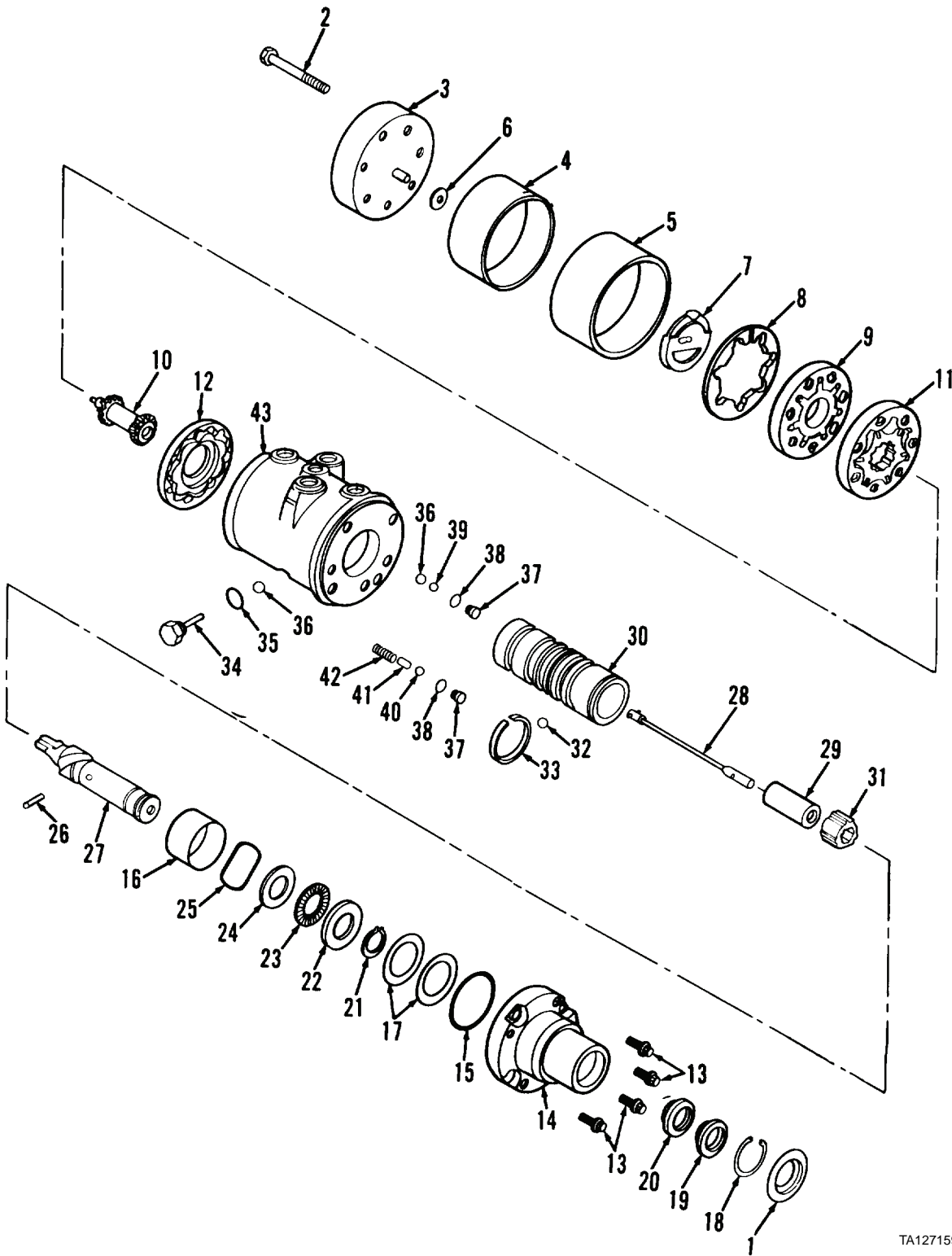

TA127159

Figure 17. Steering Gear Components.

END OF TASK

**INSTALLATION**

1. At instrument panel, install steering gear from bottom of instrument panel with four new lockwashers and capscrews (Figure 18).

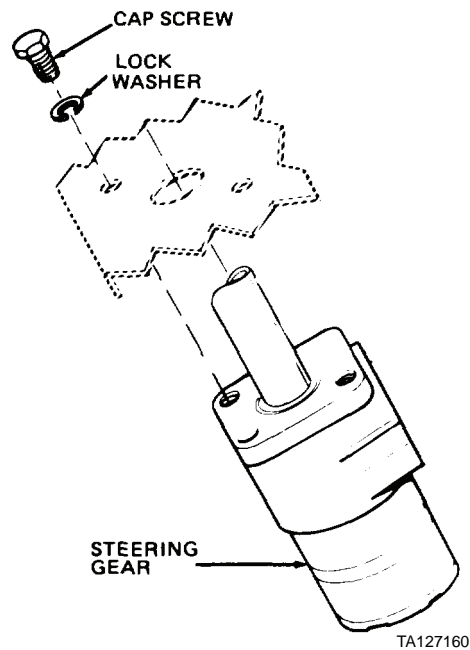

**Figure 18. Steering Gear.**

**NOTE**

Remove plugs from cylinder inlet or outlet ports as necessary.

2. Connect hoses and fittings to steering gear (WP 0172).
3. Install steering wheel and column (WP 0257).
4. If input shaft and/or upper cover have been replaced, check difference in torque required for left and right turn. If torque difference is more than 2 lb-in. (0.23 Nm), remove steering gear and add or remove shims. (Add shims to increase effort in left turn. Remove shims to increase steering effort in right turn.)

**END OF TASK**

**END OF WORK PACKAGE**

---

## DIRECT SUPPORT MAINTENANCE INSTRUCTIONS

### HYDRAULIC PUMP REPAIR

Disassembly, Cleaning, Inspection, Assembly

---

#### INITIAL SETUP

##### Maintenance Level

Direct Support

##### Tools and Special Tools

Tool kit, general mechanic's (Item 15, WP 0309)

Shop equipment, common no. 1 (Item 2, WP 0309)

Micrometer, 5 in.

Seal driver, 1-15/16 in.

##### Materials/Parts

Cleaning compound, solvent (Item 10, WP 0310)

Rag, wiping (Item 26, WP 0310)

Cellophane tape

Diaphragm

##### Materials/Parts - Continued

Gasket, back-up

Gasket, protector

O-ring (3)

Seal repair kit (P/N G34819)

Seal, shaft

Spring (2)

Steel ball (2)

Thrust plate

##### Equipment Condition

Vehicle parked on level surface

Engine OFF

Hydraulic pump removed (WP 0170)

---

**DISASSEMBLY**

1. Clamp hydraulic pump in vise with drive shaft (Figure 1, Item 6) facing upward.
2. Using a center punch and hammer, make match marks on back plate (Figure 1, Item 4), body (Figure 1, Item 5), and front plate (Figure 1, Item 3).
3. Remove eight capscrews (Figure 1, Item 2) from front plate (Figure 1, Item 3).
4. Remove hydraulic pump from vise.

**CAUTION**

Do not attempt to pry front plate and back plate apart. Prying them apart will damage machined surfaces.

5. While holding hydraulic pump in both hands, bump drive shaft (Figure 1, Item 6) against a wooden block to separate front plate (Figure 1, Item 3) and back plate (Figure 1, Item 4).
6. Remove drive shaft (Figure 1, Item 6) and idler shaft (Figure 1, Item 7) from bushings (Figure 1, Item 25) in either front plate (Figure 1, Item 3) or back plate (Figure 1, Item 4).

**NOTE**

Do not attempt to remove bushings from front plate or back plate. Bushings are not serviceable separately.

7. Remove body (Figure 1, Item 5) by placing drive shaft (Figure 1, Item 6) in bushing (Figure 1, Item 25) of plate attached to body. Lightly tap drive shaft with plastic hammer until body separates from front plate (Figure 1, Item 3) or back plate (Figure 1, Item 4).
8. At back plate (Figure 1, Item 4), remove O-ring (Figure 1, Item 8) and thrust plate (Figure 1, Item 9). Discard O-ring.
9. At front plate (Figure 1, Item 3), remove O-ring (Figure 1, Item 8). Discard O-ring.

**CAUTION**

Take care to ensure machined surface of front plate is not scratched or damaged.

10. Using a sharp instrument, pry diaphragm (Figure 1, Item 10) loose from front plate (Figure 1, Item 3).
11. Remove two springs (Figure 1, Item 11), steel balls (Figure 1, Item 12), back-up gasket (Figure 1, Item 13), protector gasket (Figure 1, Item 14), and seal (Figure 1, Item 15) from front plate (Figure 1, Item 3). Discard springs, steel balls, gaskets, and seal.
12. Remove shaft seal (Figure 1, Item 16) from front of front plate (Figure 1, Item 3). Discard shaft seal.

**NOTE**

Remove retaining rings and key only if necessary for replacement. Shafts and gears (Figure 1, Items 18 and 20) are not serviceable separately.

13. At drive shaft (Figure 1, Item 6) and idler shaft (Figure 1, Item 7), remove two retaining rings (Figure 1, Item 17) and two retaining rings (Figure 1, Item 19).
14. Remove key (Figure 1, Item 1) from drive shaft (Figure 1, Item 6).

**CAUTION**

Take care to ensure machined surface of body is not scratched or damaged.

15. If necessary for replacement, remove two dowel pins (Figure 1, Item 21) and intake tube (Figure 1, Item 22) from body (Figure 1, Item 5).

DISASSEMBLY - CONTINUED

NOTE

Perform step 16 for vehicles with serial number 9150018 and below.

16. Remove plug (Figure 1, Item 23) from back plate (Figure 1, Item 4).

NOTE

Perform step 17 for vehicles with serial number 9150019 and above.

17. Remove cap (Figure 1, Item 23A), coupler (Figure 1, Item 23B), fitting (Figure 1, Item 23C), and connector (Figure 1, Item 23D) from back plate (Figure 1, Item 4).
18. Remove O-ring (Figure 1, Item 24) from back plate (Figure 1, Item 4). Discard O-ring.

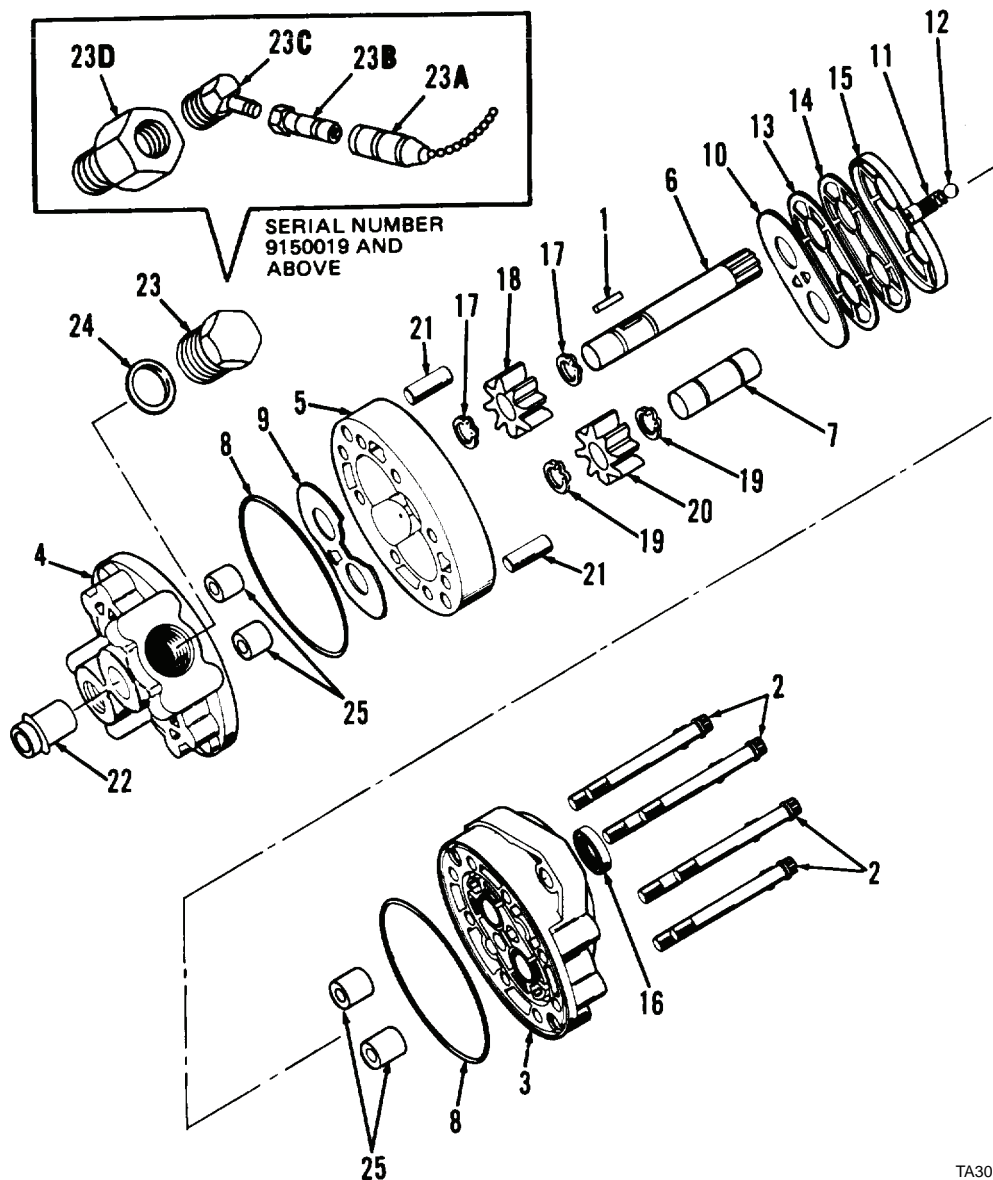

TA301533

Figure 1. Hydraulic Pump Components.

END OF TASK

**CLEANING****WARNING**

- Solvent cleaning compound MIL-PRF-680 Type III is an environmentally compliant and low toxic material. However, it may be irritating to the eyes and skin. Use protective gloves and goggles. Use in well-ventilated areas. Keep away from open flames and other sources of ignition. Failure to do so may result in injury or death to personnel.
- Particles blown by compressed air are hazardous. DO NOT exceed 15 PSI (103 kPa) nozzle pressure when drying parts with compressed air. DO NOT direct compressed air against human skin. Make sure air stream is directed away from user and other personnel in the area. To prevent injury, user must wear protective goggles or face shield. Failure to follow this warning may result in injury to personnel.

Clean all parts with solvent cleaning compound. Dry thoroughly with compressed air.

**END OF TASK****INSPECTION**

1. Inspect drive shaft (Figure 2, Item 6). Replace drive shaft and gear (Figure 2, Item 18) if shaft keyway is broken, splines are chipped or damaged, or if shaft is nicked, burred, or worn to less than 0.873 in. (22.17 mm) diameter in bushing areas.
2. Inspect idler shaft (Figure 2, Item 7). Replace idler shaft and gear (Figure 2, Item 20) if shaft is nicked, burred, or worn to less than 0.873 in. (22.17 mm) diameter in bushing areas.
3. Inspect gears (Figure 2, Items 18 and 20). Replace gears and shafts (Figure 2, Items 6 and 7) if gear teeth are chipped or broken, gear ends scored or worn, or if gear width is less than 0.732 in. (18.59 mm). Break any sharp edges of gear teeth with emery cloth.
4. Inspect retaining rings (Figure 2, Items 17 and 19). Replace if cracked, worn, or damaged.
5. Inspect capscrews (Figure 2, Item 2), plug (Figure 2, Item 23), cap (Figure 2, Item 24), coupler (Figure 2, Item 25), fitting (Figure 2, Item 26), and connector (Figure 2, Item 27). Replace if cracked, worn, or damaged.
6. Inspect two bushings (Figure 2, Item 25). Replace front plate (Figure 2, Item 3) or back plate (Figure 2, Item 4) if bushings are scored or pitted, or if oil grooves are damaged, front plate bushing is not flush with islands in groove patterns, or if bushing is worn to less than 0.0879 in. (2.233 mm) inside diameter.
7. Inspect key (Figure 2, Item 1). Replace if cracked or worn, or if it fits loosely in keyway of drive shaft (Figure 2, Item 6).
8. Inspect dowel pins (Figure 2, Item 21) and intake tube (Figure 2, Item 22). Replace if cracked or damaged.
9. Inspect front plate (Figure 2, Item 3). Replace if machined face is scored, pitted, or eroded.
10. Inspect back plate (Figure 2, Item 4). Replace if machined face is scored, pitted, eroded, or if threads are damaged.
11. Inspect body (Figure 2, Item 5). Replace if machined faces are scored, pitted, eroded, or if inside diameter of gear pocket is scored, pitted, or worn to less than 2.107 in. (53.52 mm).



INSPECTION - CONTINUED

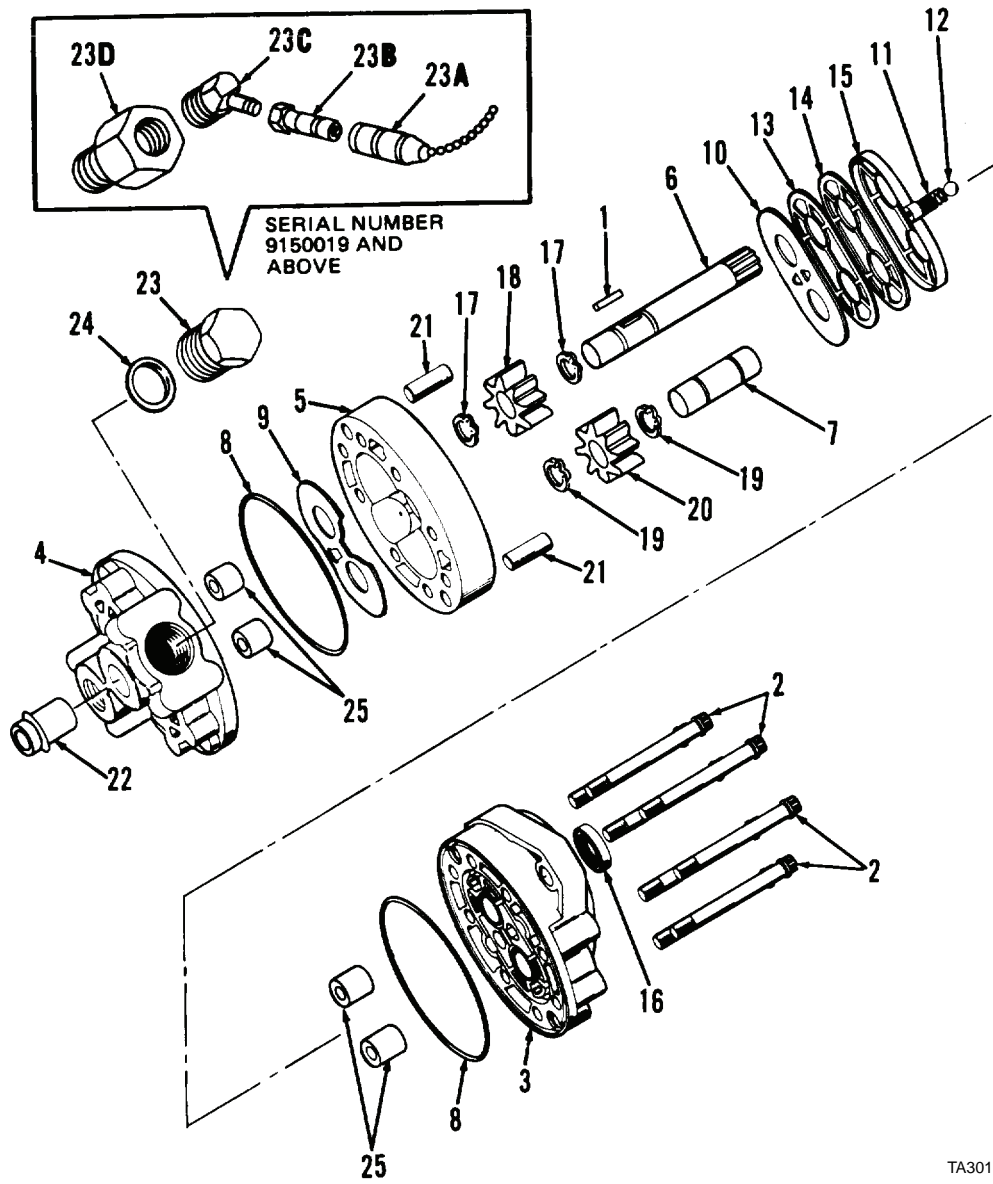

TA301533

Figure 2. Hydraulic Pump Components.

END OF TASK

**ASSEMBLY**

1. Install new O-ring (Figure 3, Item 8) in groove of front plate (Figure 3, Item 3).
2. Install new seal (Figure 3, Item 15) on front plate (Figure 3, Item 3) with open part of “V” section down. Press seal into grooves in front plate.
3. Press new gaskets (Figure 3, Items 14 and 13) into seal (Figure 3, Item 15).
4. Position two new steel balls (Figure 3, Item 12) and new springs (Figure 3, Item 11) into bores of front plate (Figure 3, Item 3).

**CAUTION**

In step 5, ensure diaphragm fits inside rim of seal. Also, ensure coils of springs are not wedged between diaphragm and front plate.

5. Install diaphragm (Figure 3, Item 10), bronze face up, into raised rim of seal (Figure 3, Item 15) and against back-up gasket (Figure 3, Item 13).
6. Position key (Figure 3, Item 1) in keyway of shaft (Figure 3, Item 6).
7. Apply coat of hydraulic oil to two gears (Figure 3, Items 18 and 20) and position gears on shafts (Figure 3, Items 6 and 7).
8. Install two retaining rings (Figure 3, Item 17) on drive shaft (Figure 3, Item 6).
9. Install two retaining rings (Figure 3, Item 19) on idler shaft (Figure 3, Item 7).
10. Apply coat of hydraulic oil to shafts (Figure 3, Items 6 and 7) and position in bushing (Figure 3, Item 25) of front plate (Figure 3, Item 3).
11. Install two dowel pins (Figure 3, Item 21) on body (Figure 3, Item 5), if removed.
12. Apply thin coat of heavy grease to both machined faces of body (Figure 3, Item 5). Position body with small drilled hole in one cavity toward pressure side of pump, and with half-moon port cavities facing away from front plate (Figure 3, Item 3). Slip body over gears (Figure 3, Items 18 and 20) and onto front plate.
13. Install thrust plate (Figure 3, Item 9) with bronze face towards gears, and side with mid-section cut-away toward suction side pump. Position thrust plate over gears (Figure 3, Items 18 and 20) and into gear pockets of body (Figure 3, Item 5).
14. Install intake tube (Figure 3, Item 22) on back plate (Figure 3, Item 4) by placing machined surface of back plate on a block of wood. Drive intake tube into back plate using a plastic hammer.
15. Install new O-ring (Figure 3, Item 8) into groove of back plate (Figure 3, Item 4).
16. Install back plate (Figure 3, Item 4) over shafts (Figure 3, Items 6 and 7) and against body (Figure 3, Item 5) until dowel pins (Figure 3, Item 21) are engaged.
17. Install eight capscrews (Figure 3, Item 2) on front plate (Figure 3, Item 3). Tighten capscrews evenly to 40 lb-ft (54 Nm).
18. Install new O-ring (Figure 3, Item 24) on plug (Figure 3, Item 23) or connector (Figure 3, Item 23D).

**NOTE**

Perform step 19 for vehicles with serial number 9150019 and above.

19. Install connector (Figure 3, Item 23D), fitting (Figure 3, Item 23C), coupler (Figure 3, Item 23B), and cap (Figure 3, Item 23A) on back plate (Figure 3, Item 4).

**NOTE**

Perform step 20 for vehicles with serial number 9150018 and below.

20. Install plug (Figure 3, Item 23) on back plate (Figure 3, Item 4).

**ASSEMBLY - CONTINUED**

**NOTE**

Cover end of drive shaft with cellophane tape to protect new shaft seal from edges of shaft.

21. Apply coat of hydraulic oil to new shaft seal (Figure 3, Item 16) and install seal over drive shaft (Figure 3, Item 6). Seat seal into front plate (Figure 3, Item 3) using 1-15/16-in. seal driver and hammer.
22. Check drive shaft (Figure 3, Item 6) for binding. Using a wrench or similar tool, rotate drive shaft 10 revolutions. Drive shaft should be almost free enough to rotate by hand. If drive shaft binds, disassemble pump and determine cause.

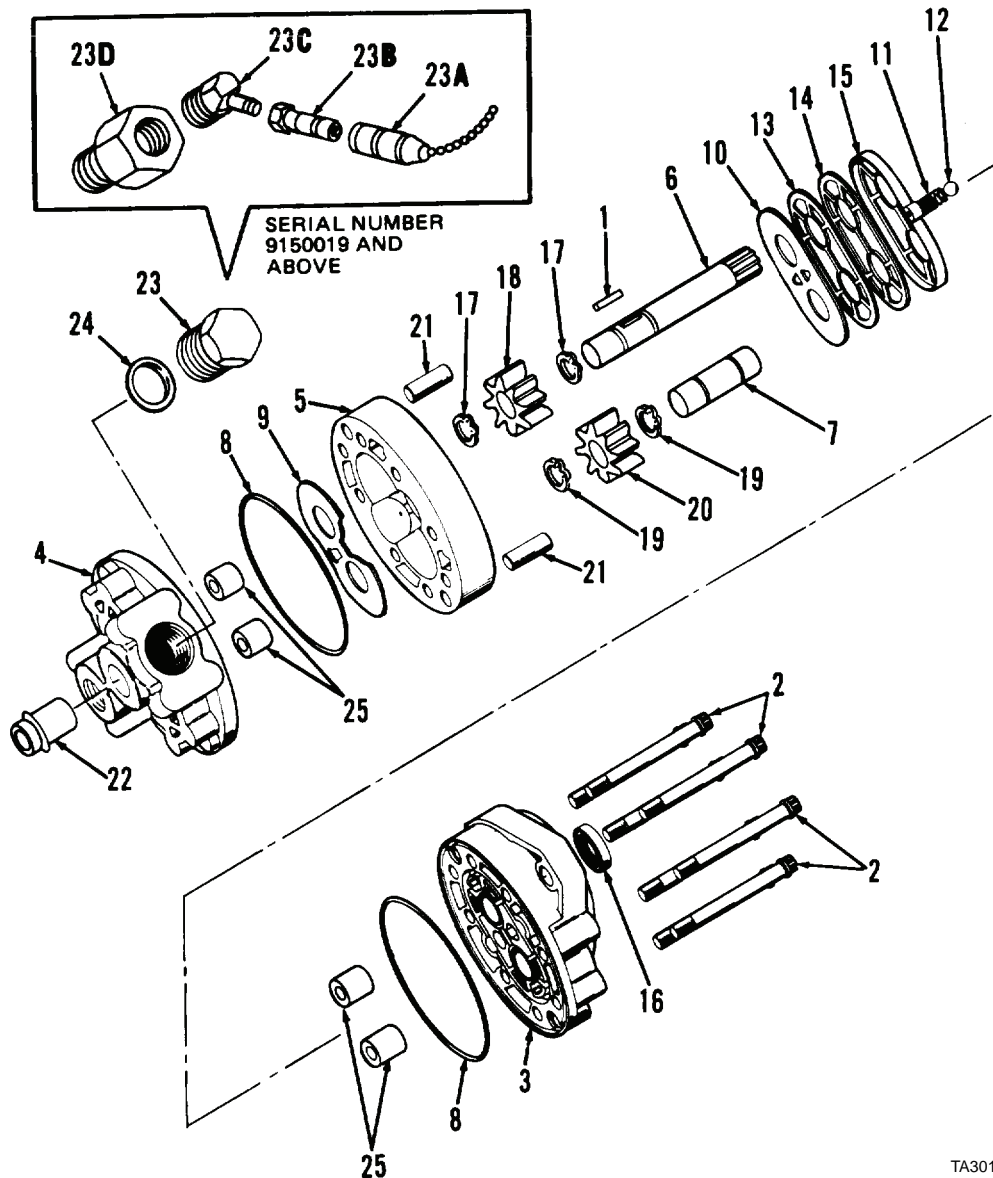

TA301533

**Figure 3. Hydraulic Pump Components.**

**END OF TASK**

**END OF WORK PACKAGE**



---

## DIRECT SUPPORT MAINTENANCE INSTRUCTIONS

### STEERING CYLINDER REPAIR Disassembly, Cleaning, Inspection, Assembly

---

#### INITIAL SETUP

##### Maintenance Level

Direct Support

##### Tools and Special Tools

Tool kit, general mechanic's (Item 15, WP 0309)  
Shop equipment, common no. 1 (Item 2, WP 0309)  
Spanner wrench (Item 9, WP 0309)  
Emery cloth, medium grit

##### Materials/Parts

Cleaning compound, solvent (Item 10, WP 0310)  
Lubricating oil, OE/HDO-10 (Item 20, WP 0310)  
Rag, wiping (Item 26, WP 0310)  
Seal repair kit (P/N G34819)

##### Equipment Condition

Vehicle parked on level surface  
Engine OFF  
Steering cylinder removed (WP 0173)

---

**DISASSEMBLY**

1. Remove screw (Figure 1, Item 1) from cylinder (Figure 1, Item 18).
2. Using spanner wrench, loosen gland (Figure 1, Item 2) and remove gland and piston rod (Figure 1, Item 3) assembly from cylinder (Figure 1, Item 18).
3. At piston rod (Figure 1, Item 3), remove capscrew (Figure 1, Item 4), washer (Figure 1, Item 5), piston (Figure 1, Item 6), and gland (Figure 1, Item 2) from piston rod.

**NOTE**

Remove grease fitting, retaining rings, and bushing only if necessary for replacement.

4. Remove grease fitting (Figure 1, Item 14), two retaining rings (Figure 1, Item 15), and bushing (Figure 1, Item 16) from piston rod (Figure 1, Item 3).
5. At piston (Figure 1, Item 6), remove wear ring (Figure 1, Item 7), seal ring (Figure 1, Item 8), and O-ring (Figure 1, Item 9). Discard wear ring, seal ring, and O-ring.
6. At gland (Figure 1, Item 2), remove O-ring (Figure 1, Item 10) and back-up ring (Figure 1, Item 11). Discard O-ring and back-up ring.
7. Remove wiper (Figure 1, Item 12) and rod seal (Figure 1, Item 13) from inside of gland (Figure 1, Item 2). Use a fine wire to hook wiper and rod seal and pull out of gland. Discard wiper and rod seal.
8. At cylinder (Figure 1, Item 18), remove two bushings (Figure 1, Item 17), if necessary for replacement.

**END OF TASK****CLEANING****WARNING**

- Solvent cleaning compound MIL-PRF-680 Type III is an environmentally compliant and low toxic material. However, it may be irritating to the eyes and skin. Use protective gloves and goggles. Use in well-ventilated areas. Keep away from open flames and other sources of ignition. Failure to do so may result in injury or death to personnel.
- Particles blown by compressed air are hazardous. DO NOT exceed 15 PSI (103 kPa) nozzle pressure when drying parts with compressed air. DO NOT direct compressed air against human skin. Make sure air stream is directed away from user and other personnel in the area. To prevent injury, user must wear protective goggles or face shield. Failure to follow this warning may result in injury to personnel.

Clean all parts except bushings (Figure 1, Items 16 and 17) with solvent cleaning compound. Dry thoroughly with compressed air.

**END OF TASK**

## INSPECTION

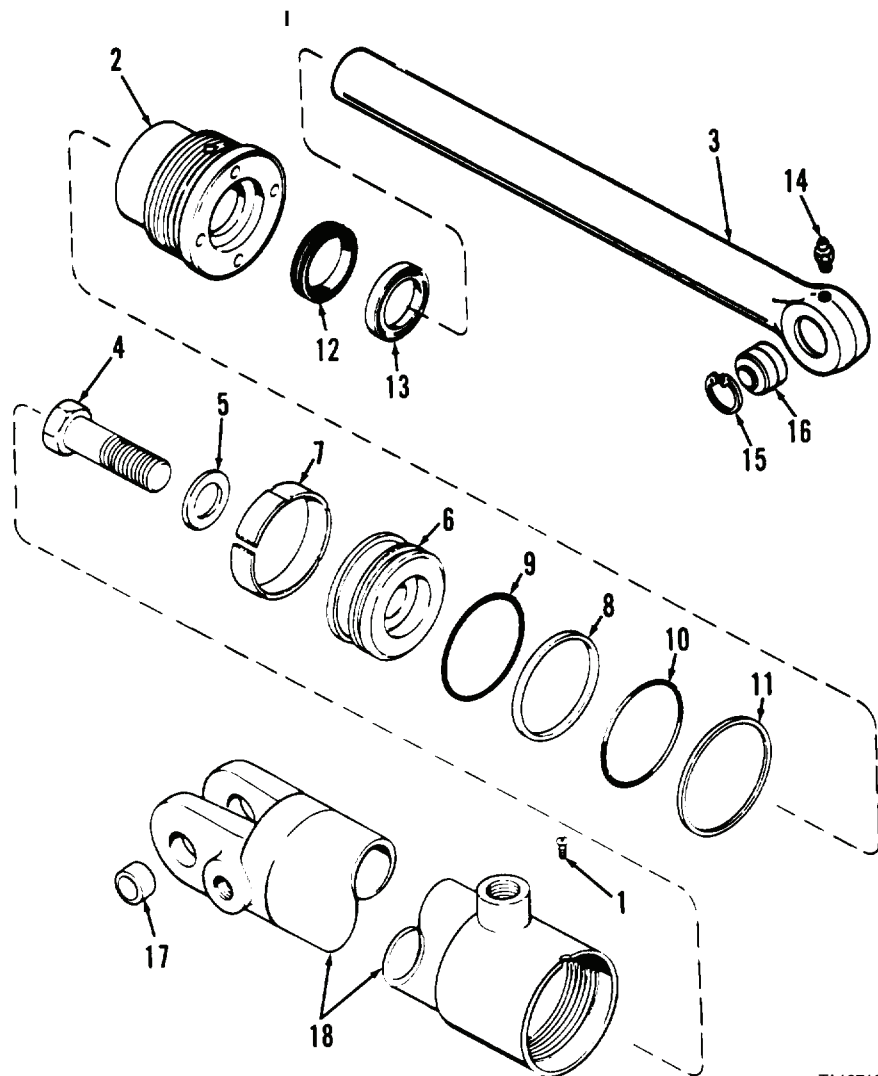

TA127168

**Figure 1. Steering Cylinder.**

1. Inspect screws (Figure 1, Items 1 and 4) and grease fitting (Figure 1, Item 14). Replace if worn, or threads are damaged.
2. Inspect gland (Figure 1, Item 2). Replace if cracked or broken, or if threads are damaged.
3. Inspect piston (Figure 1, Item 6), washer (Figure 1, Item 5), and retaining ring (Figure 1, Item 15). Replace if cracked or damaged.
4. Inspect piston rod (Figure 1, Item 3). Repair nicks or scratches with medium-grit emery cloth, polishing with a rotary motion. Replace if cracked or bent, if deeply grooved or scored, or if threads are damaged.
5. Inspect bushings (Figure 1, Items 16 and 17). Replace if cracked or worn.
6. Inspect cylinder (Figure 1, Item 18). Repair nicks or scratches in cylinder with medium-grit emery cloth, polishing with a rotary motion. Replace if cracked or dented, if deeply grooved or scored, or if threads damaged.

**END OF TASK**

**ASSEMBLY**

1. At inside of gland (Figure 2, Item 2), install new rod seal (Figure 2, Item 13) with lip of seal facing piston side of gland.
2. Install new wiper (Figure 2, Item 12) on inside of gland (Figure 2, Item 2) with wiper lip away from gland, and press into gland until seated.
3. Install new back-up ring (Figure 2, Item 11) and O-ring (Figure 2, Item 10) on outside of gland (Figure 2, Item 2).
4. Apply coat of clean lubricating oil to bore of gland and slide gland onto piston rod (Figure 2, Item 3).
5. At piston (Figure 2, Item 6), install new O-ring (Figure 2, Item 9) in narrow groove of piston.

**CAUTION**

Ensure that O-ring and seal ring are not rolled when seated.

6. Install new seal ring (Figure 2, Item 8) over O-ring (Figure 2, Item 9).
7. Install new wear ring (Figure 2, Item 7) in wide groove of piston (Figure 2, Item 6).
8. Install piston (Figure 2, Item 6) on piston rod (Figure 2, Item 3) with recess of piston facing piston rod.
9. Clamp piston rod (Figure 2, Item 3) in soft-jawed vise.
10. Install washer (Figure 2, Item 5) and capscrew (Figure 2, Item 4) on piston (Figure 2, Item 6). Tighten capscrew to 150 to 180 lb-ft (203 to 244 Nm).
11. Apply clean hydraulic oil to piston (Figure 2, Item 6).

**CAUTION**

Be careful not to cut or damage O-rings and seals in step 12.

12. Carefully guide piston (Figure 2, Item 6) and piston rod (Figure 2, Item 3) assembly into cylinder (Figure 2, Item 18).
13. Clamp cylinder (Figure 2, Item 18) in soft-jawed vise.
14. Using spanner wrench, tighten gland (Figure 2, Item 2).
15. Install screw (Figure 2, Item 1) on cylinder (Figure 2, Item 18) to retain gland (Figure 2, Item 2).
16. Install grease fitting (Figure 2, Item 14).
17. Install two bushings (Figure 2, Item 16) on cylinder (Figure 2, Item 18), if removed.
18. Install bushing (Figure 2, Item 17) and two retaining rings (Figure 2, Item 15) on cylinder (Figure 2, Item 18).



ASSEMBLY - CONTINUED

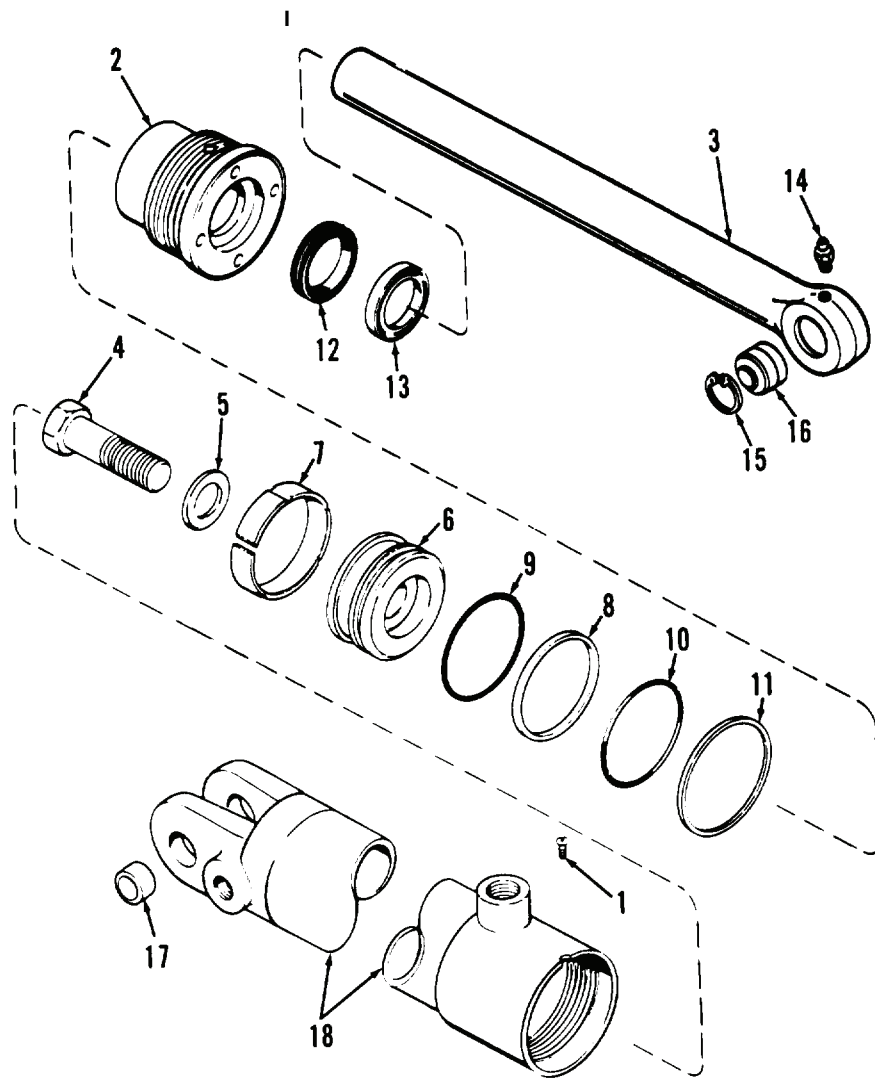

TA127168

Figure 2. Steering Cylinder.

END OF TASK

END OF WORK PACKAGE



---

## DIRECT SUPPORT MAINTENANCE INSTRUCTIONS

### SEPARATION OF FRONT AND REAR CHASSIS

#### Separation, Cleaning, Inspection, and Installation of Front and Rear Chassis

---

#### INITIAL SETUP

##### Maintenance Level

Direct Support

##### Tools and Special Tools

Tool kit, general mechanic's (Item 15, WP 0309)  
 Shop equipment, common no. 1 (Item 2, WP 0309)  
 Wood blocks (2), 12 x 12 x 30 in.

##### Materials/Parts

Cleaning compound, solvent (Item 10, WP 0310)  
 Rag, wiping (Item 26, WP 0310)  
 Locknut

##### Personnel Required

Two

##### Equipment Condition

Battery ground cable disconnected (WP 0133 and WP 0134)

##### Equipment Condition - Continued

Accelerator cable disconnected (WP 0074 and WP 0075)  
 Front wiring harness connector unplugged (WP 0135 and WP 0136)  
 Transmission linkage cables disconnected (WP 0148)  
 Parking brake linkage disconnected from transmission parking brake (WP 0161)  
 Hydraulic pump hoses disconnected (WP 0172)  
 Steering cylinder rods disconnected from rear chassis (WP 0173)  
 Hydraulic oil filter-to-control valve hose disconnected (WP 0195)  
 Center drive shaft removed (WP 0155)  
 Declutch valve outlet hose disconnected from transmission, and rear brake supply hose disconnected from hydraulic brake valve (WP 0164)

---

**REMOVAL**

1. Use hoist or other lifting device attached to ROPS side supports to prevent front chassis from tipping when pulled from rear chassis.
2. Block wheels and frame to prevent rear chassis from moving or tipping when front chassis is removed.
3. Remove retaining ring (Figure 1, Item 1).
4. Remove upper pivot pin (Figure 1, Item 2). If necessary, tap bottom of pivot pin using drift and hammer.

**WARNING**

Front chassis and rear chassis are extremely heavy. Do not proceed unless chassis are secured to prevent movement and tipping. Failure to do so could cause injury or death to personnel.

5. Remove locknut (Figure 1, Item 3), two washers (Figure 1, Item 4), two spacers (Figure 1, Item 5), and lower pivot pin (Figure 1, Item 6) from pivot assembly. If necessary, tap top of pivot pin using drift and hammer. Discard locknut.
6. Remove two pivot bearings (Figure 1, Item 7) from pivot assembly.
7. Remove pivot bushing (Figure 1, Item 8) from lower pivot bearing (Figure 1, Item 7).
8. Remove two grease fittings (Figure 1, Item 9).

REMOVAL - CONTINUED

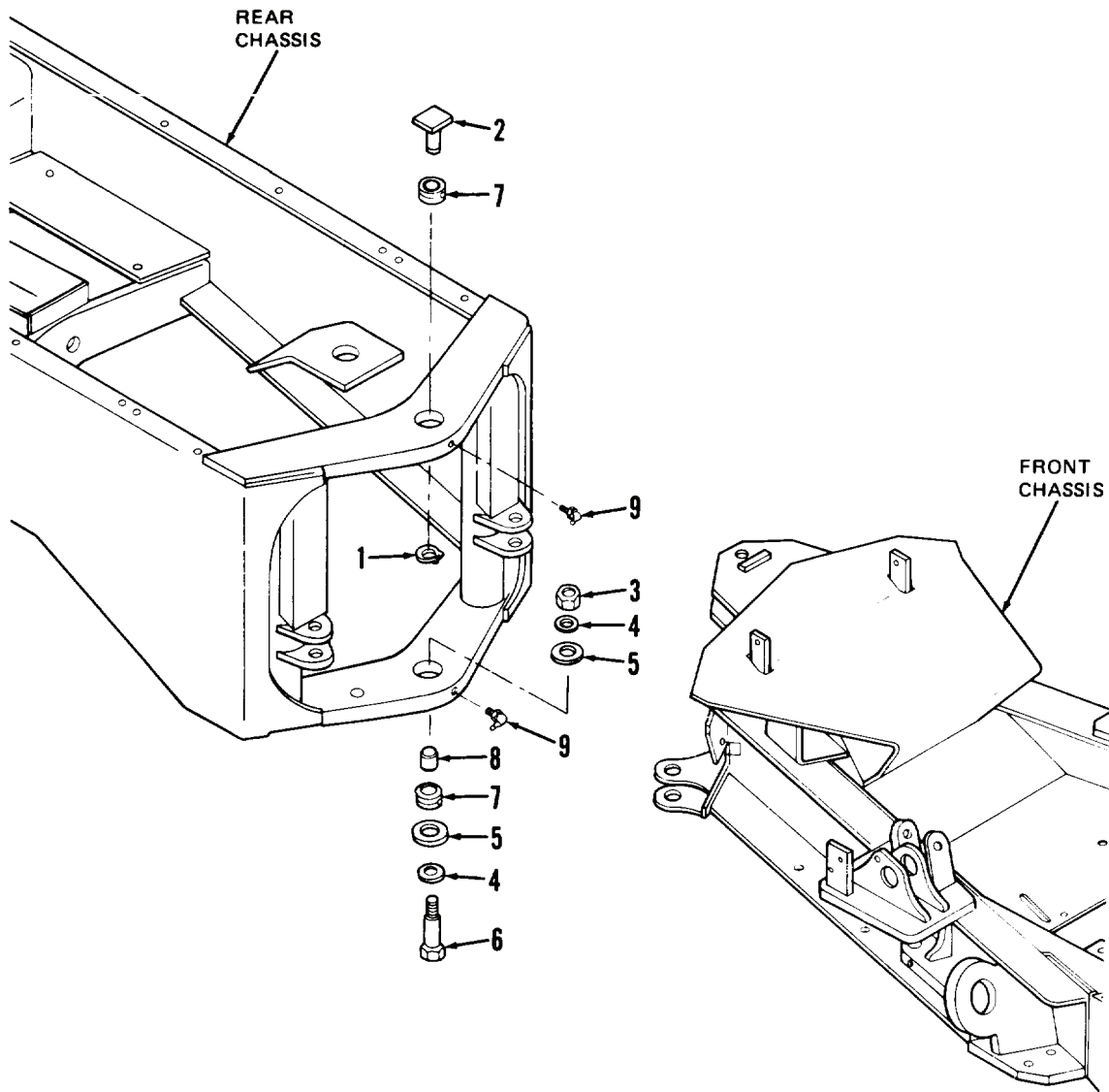

TA127169

Figure 1. Front and Rear Chassis.

END OF TASK

## CLEANING

1. Wipe two pivot bearings (Figure 2, Item 7) with clean rag only.



- Solvent cleaning compound MIL-PRF-680 Type III is an environmentally compliant and low toxic material. However, it may be irritating to the eyes and skin. Use protective gloves and goggles. Use in well-ventilated areas. Keep away from open flames and other sources of ignition. Failure to do so may result in injury or death to personnel.
  - Particles blown by compressed air are hazardous. DO NOT exceed 15 PSI (103 kPa) nozzle pressure when drying parts with compressed air. DO NOT direct compressed air against human skin. Make sure air stream is directed away from user and other personnel in the area. To prevent injury, user must wear protective goggles or face shield. Failure to follow this warning may result in injury to personnel.
2. Use solvent cleaning compound to clean all other parts. Dry thoroughly with moisture-free compressed air.

## END OF TASK

## INSPECTION

1. Inspect two pivot bearings (Figure 2, Item 7). Replace if cracked, worn, or deteriorated.
2. Inspect all other parts. Replace if worn or if threads damaged.

## END OF TASK

## INSTALLATION

1. Install two grease fittings (Figure 2, Item 9) on rear chassis with fitting inlet facing left or right side of vehicle and tighten.
2. Install pivot bushing (Figure 2, Item 8) by pressing into lower pivot bearing (Figure 2, Item 7).
3. Install two pivot bearings (Figure 2, Item 7) by pressing into pivot bores in rear chassis.
4. Position front chassis and push against rear chassis until upper and lower pivot bores are aligned.
5. Install upper pivot pin (Figure 2, Item 2) on upper pivot bearing (Figure 2, Item 7). If necessary, gently tap into pivot bearing using hammer.
6. Install retaining ring (Figure 2, Item 1) on upper pivot bearing (Figure 2, Item 7).
7. Install lower pivot pin (Figure 2, Item 6) with washer (Figure 2, Item 4) and spacer (Figure 2, Item 5) on pivot assembly. If necessary, gently tap into bushing (Figure 2, Item 8) using hammer.
8. Install spacer (Figure 2, Item 5), washer (Figure 2, Item 4), and new locknut (Figure 2, Item 3) and tighten locknut and lower pivot pin (Figure 2, Item 6) to 340 to 360 lb-ft (461 to 488 Nm).

INSTALLATION - CONTINUED

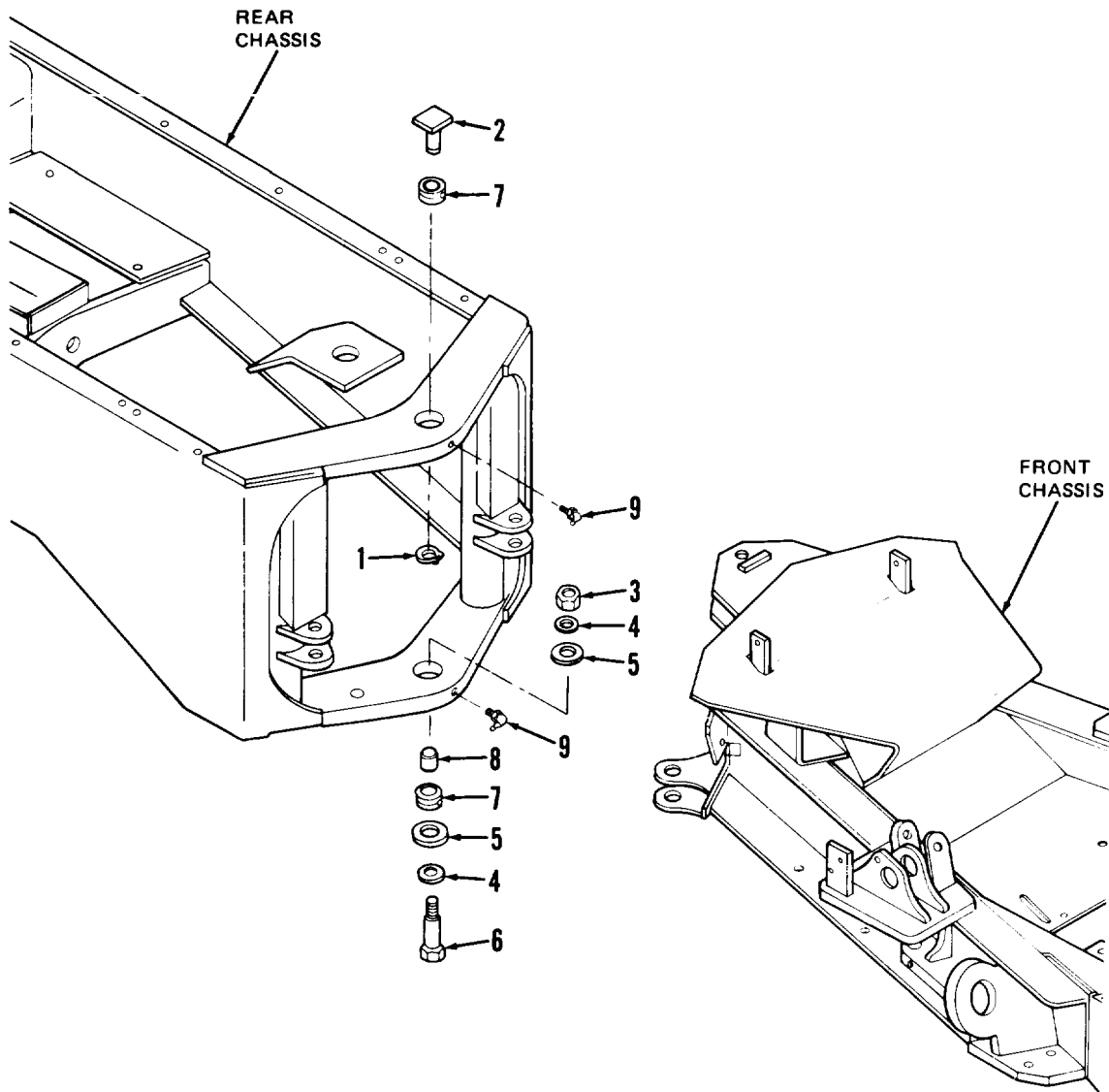

TA127169

Figure 2. Front and Rear Chassis.

END OF TASK

END OF WORK PACKAGE





---

## DIRECT SUPPORT MAINTENANCE INSTRUCTIONS

### HYDRAULIC CONTROL VALVE MAINTENANCE

Removal; Disassembly Into Sections; Left Cover Plate Disassembly; Rotate, Sideshift, and Tilt Valve Sections Disassembly; Lift Valve Section Disassembly; Cleaning; Inspection/Repair; Rotate, Sideshift, and Tilt Valve Sections Assembly; Lift Valve Section Assembly; Final Assembly; Installation/Replacement

---

#### INITIAL SETUP

##### Maintenance Level

Direct Support

##### Tools and Special Tools

Tool kit, general mechanic's (Item 15, WP 0309)  
Shop equipment, common no. 1 (Item 2, WP 0309)

##### Materials/Parts

Cap set, protective (Item 9, WP 0310)  
Cleaning compound, solvent (Item 10, WP 0310)  
Lubricating oil, OE/HDO-10 (Item 20, WP 0310)  
Rag, wiping (Item 26, WP 0310)  
Tag, marker (Item 33, WP 0310)  
Load check plug kit  
Load check plug seal kit  
Lockwasher (5)  
O-ring (25)  
Relief plug kit  
Relief plug seal kit  
Seal kit

##### Materials/Parts - Continued

Spool positioner kit  
Spool seal retainer kit

##### Personnel Required

Two

##### References

WP 0191  
WP 0195

##### Equipment Condition

Vehicle parked on level surface  
Mast tilted forward  
Forks resting on ground  
Engine OFF  
Parking brake applied  
Noise baffle mat removed (WP 0187)  
All control levers on control valve operated several times to relieve hydraulic pressure  
Hydraulic reservoir drained (WP 0198)

---

## REMOVAL

## NOTE

- Tag all tubes and hoses before disconnecting.
- Cap all openings after disconnecting lines and hoses.

1. Disconnect control valve linkage (Figure 1) (WP 0191, *Removal*, steps 2 through 4).



Solvent cleaning compound MIL-PRF-680 Type III is an environmentally compliant and low toxic material. However, it may be irritating to the eyes and skin. Use protective gloves and goggles. Use in well-ventilated areas. Keep away from open flames and other sources of ignition. Failure to do so may result in injury or death to personnel.

2. Use clean rag moistened with solvent cleaning compound and remove all dirt and grease from tube fittings.
3. Disconnect tube fittings (Figure 1) (WP 0195, steps 1, 3, 8, and 10).

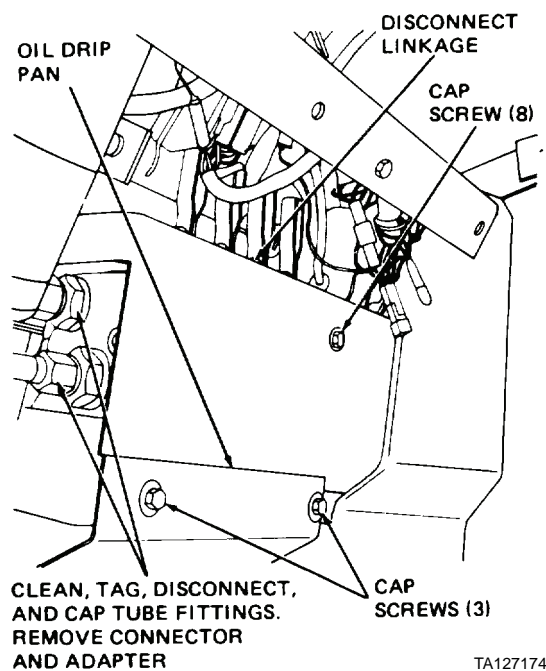
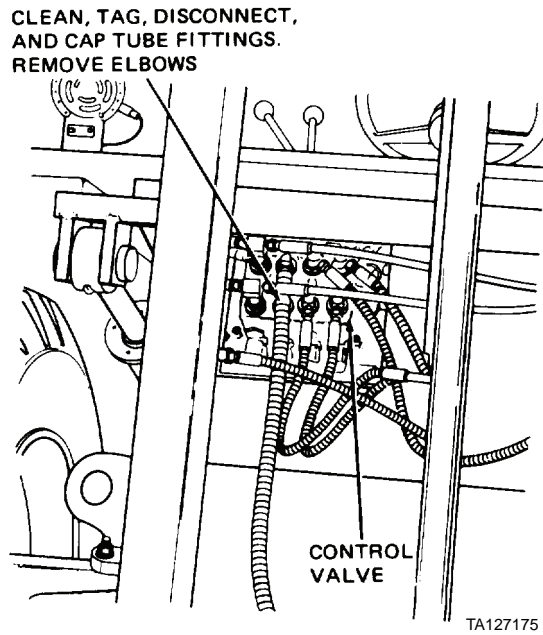

Figure 1. Hydraulic Control Valve Fasteners.

**REMOVAL - CONTINUED**

4. Use clean cloth moistened with solvent cleaning compound and remove all dirt and grease from tube fittings on control valve.
5. Disconnect tube fittings (Figure 2) (WP 0201, *Removal*, steps 11 through 16)
6. Remove elbows (Figure 2) (WP 0201, *Removal*, steps 17 through 18).



**Figure 2. Hydraulic Control Valve Hoses.**

**REMOVAL - CONTINUED**

7. Remove two nuts (Figure 3, Item 1), lockwashers (Figure 3, Item 2), capscrews (Figure 3, Item 3), and washers (Figure 3, Item 4) from control valve (Figure 3, Item 10). Discard lockwashers.
8. Remove oil drip pan (Figure 3, Item 5).

**CAUTION**

Support control valve when performing step 9 to prevent it from falling.

9. Remove nut (Figure 3, Item 6), lockwasher (Figure 3, Item 7), capscrew (Figure 3, Item 8), and washer (Figure 3, Item 9) from control valve (Figure 3, Item 10). Position axle breather hose and clamp aside. Discard lockwasher.
10. Remove control valve (Figure 3, Item 10) from vehicle.

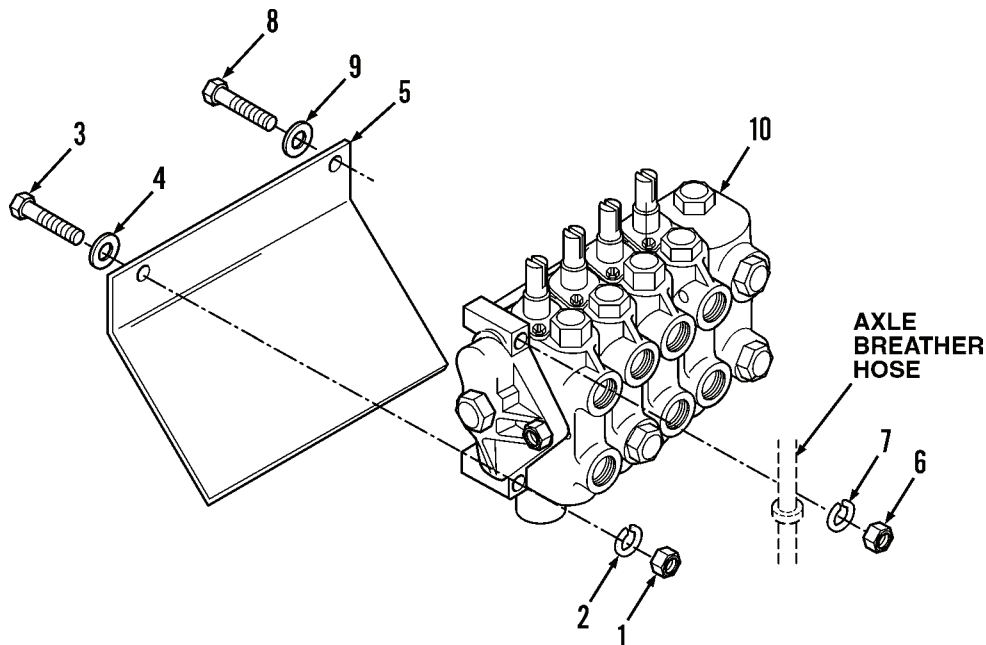

444-1285

**Figure 3. Hydraulic Control Valve and Associated Parts.**

**END OF TASK**

**DISASSEMBLY INTO SECTIONS**

1. Remove three nuts (Figure 4, Item 1) from right cover plate (Figure 4, Item 2).
2. Remove three capscrews (Figure 4, Item 8) from right cover plate (Figure 4, Item 2).

**NOTE**

O-rings are located between valve sections and cover plates. Remove as valve sections and cover plates are removed.

3. Remove and discard four O-rings (Figure 4, Items 3 and 4).
4. Lift off tilt valve section (Figure 4, Item 5), lift valve section (Figure 4, Item 6), and shift valve section (Figure 4, Item 7) from capscrews (Figure 4, Item 8).
5. Remove three capscrews (Figure 4, Item 8) from control valve assembly.
6. Separate rotate valve section (Figure 4, Item 9) and left cover plate (Figure 4, Item 10).
7. Remove plug (Figure 4, Item 11) from right cover plate (Figure 4, Item 2).
8. Remove O-ring (Figure 4, Item 12) from plug (Figure 4, Item 11). Discard O-ring.

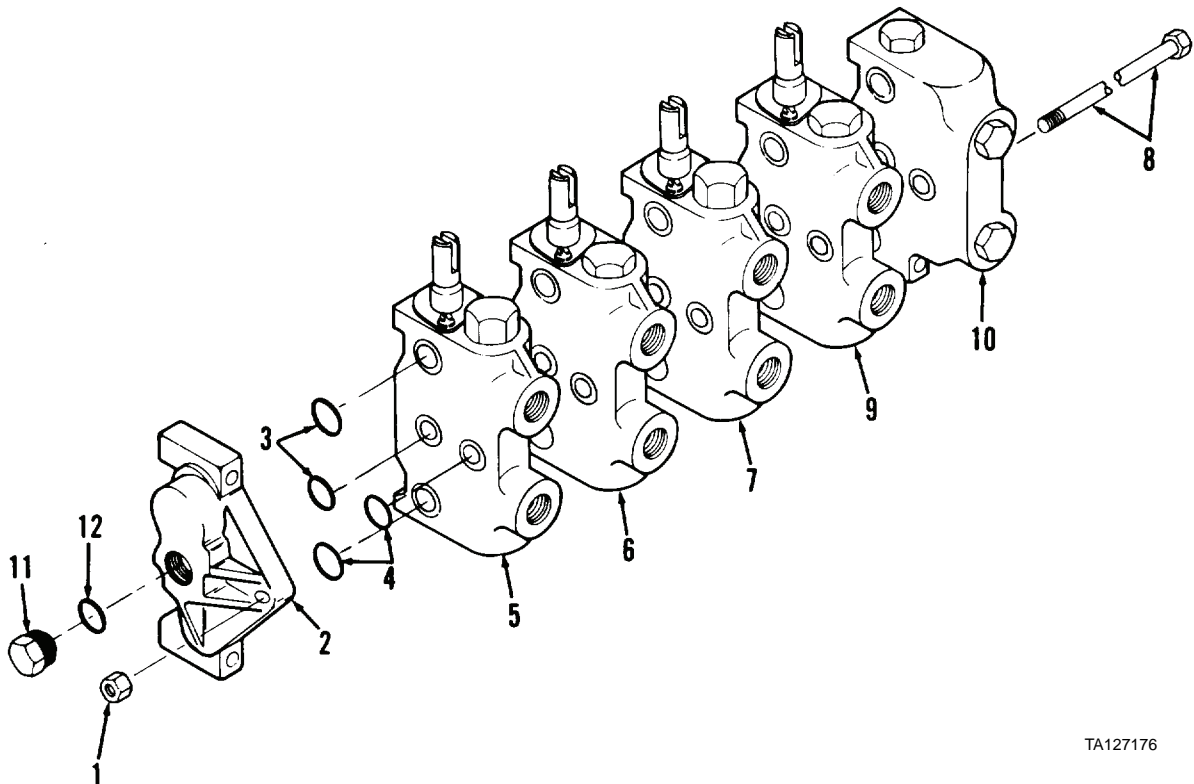

TA127176

**Figure 4. Hydraulic Control Valve Assembly.**

**END OF TASK**

**LEFT COVER PLATE DISASSEMBLY**

1. Remove relief plug assembly (Figure 5, Item 1) from left cover plate (Figure 5, Item 9).
2. Remove back-up washer (Figure 5, Item 2) from left cover plate (Figure 5, Item 9).
3. Remove O-ring (Figure 5, Item 3) from left cover plate (Figure 5, Item 9). Discard O-ring.
4. Remove back-up washer (Figure 5, Item 4) from left cover plate (Figure 5, Item 9).
5. Remove O-ring (Figure 5, Item 5) from left cover plate (Figure 5, Item 9). Discard O-ring.
6. Remove two plugs (Figure 5, Item 7) from left cover plate (Figure 5, Item 9).
7. Remove two O-rings (Figure 5, Item 8) from two plugs (Figure 5, Item 7). Discard O-rings.

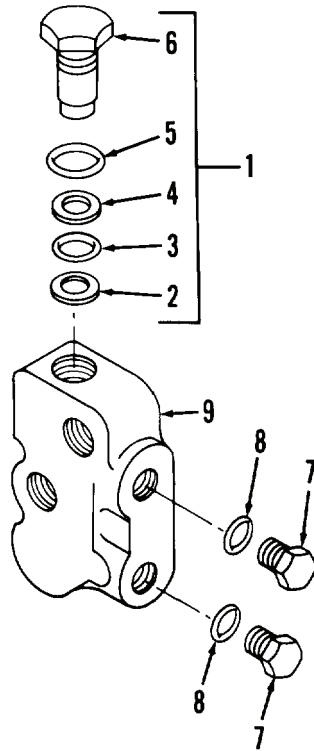

TA127177

**Figure 5. Left Cover Plate Assembly.****END OF TASK****ROTATE, SIDESHIFT, AND TILT VALVE SECTIONS DISASSEMBLY**

1. Remove two screws (Figure 6, Item 1) from seal plate (Figure 6, Item 2).
2. Remove seal plate (Figure 6, Item 2) from housing (Figure 6, Item 25).
3. Remove two screws (Figure 6, Item 3) from bonnet (Figure 6, Item 4).
4. Remove bonnet (Figure 6, Item 4) from housing (Figure 6, Item 25).
5. Remove spool (Figure 6, Item 8) from housing (Figure 6, Item 25). Use rod inserted in pin hole to remove. Do not use wrench or pliers.
6. Remove two seal retainer plates (Figure 6, Item 5), back-up rings (Figure 6, Item 6), and O-rings (Figure 6, Item 7) from top of spool (Figure 6, Item 8). Discard O-rings.
7. Remove screw (Figure 6, Item 9) and lockwasher (Figure 6, Item 10) from bottom of spool (Figure 6, Item 8). Discard lockwasher.

**ROTATE, SIDESHIFT, AND TILT VALVE SECTIONS DISASSEMBLY - CONTINUED**

8. Remove spool collar (Figure 6, Item 11), spring collar (Figure 6, Item 12), return spring (Figure 6, Item 13), and spring collar (Figure 6, Item 14) from bottom of spool (Figure 6, Item 8).
9. Remove two load check plug assemblies (Figure 6, Item 15) from bottom and top of housing (Figure 6, Item 25).
10. Remove two load check poppets (Figure 6, Item 16), poppet springs (Figure 6, Item 17), six back-up rings (Figure 6, Items 18, 20, and 22), and O-rings (Figure 6, Items 19, 21, and 23) from two check plugs (Figure 6, Item 24). Discard O-rings.

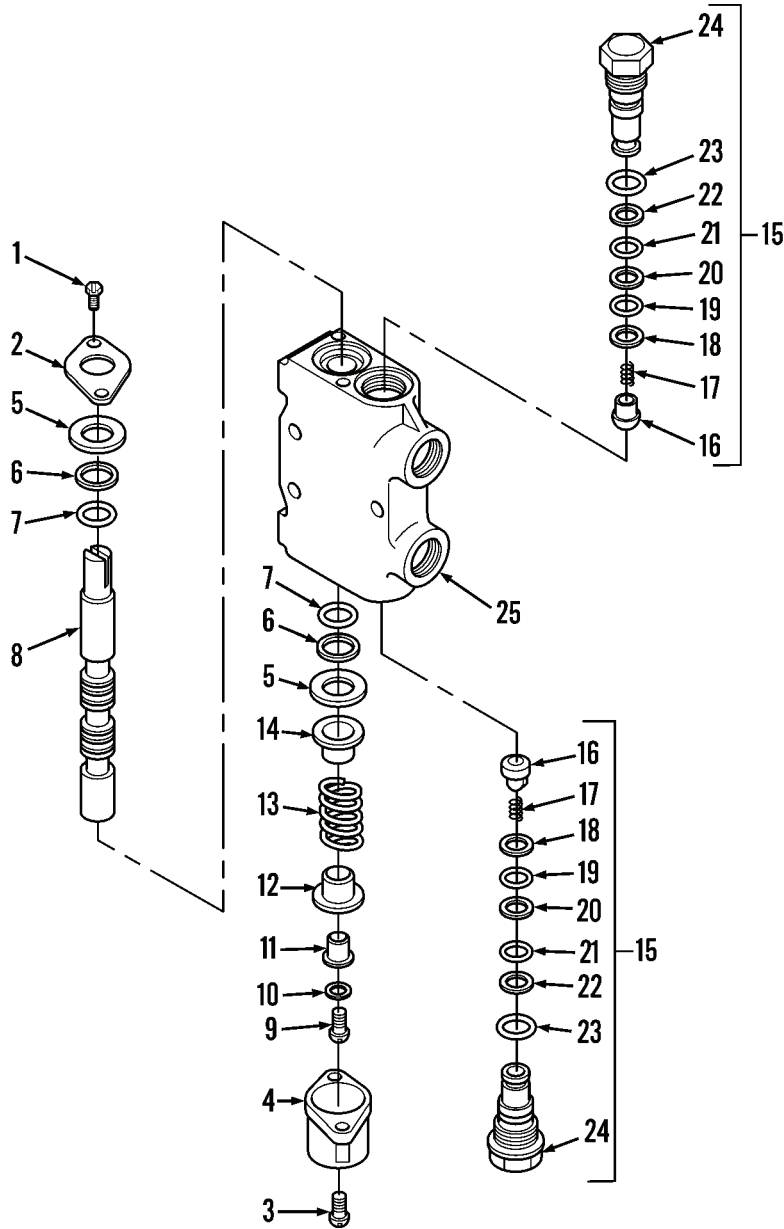

**Figure 6. Rotate, Sideshift, and Tilt Valve Sections.**

444-1288

**END OF TASK**

**LIFT VALVE SECTION DISASSEMBLY**

1. Remove two screws (Figure 7, Item 1) from seal plate (Figure 7, Item 2).
2. Remove seal plate (Figure 7, Item 2) from housing (Figure 7, Item 36).
3. Remove two screws (Figure 7, Item 3) from bonnet (Figure 7, Item 4).

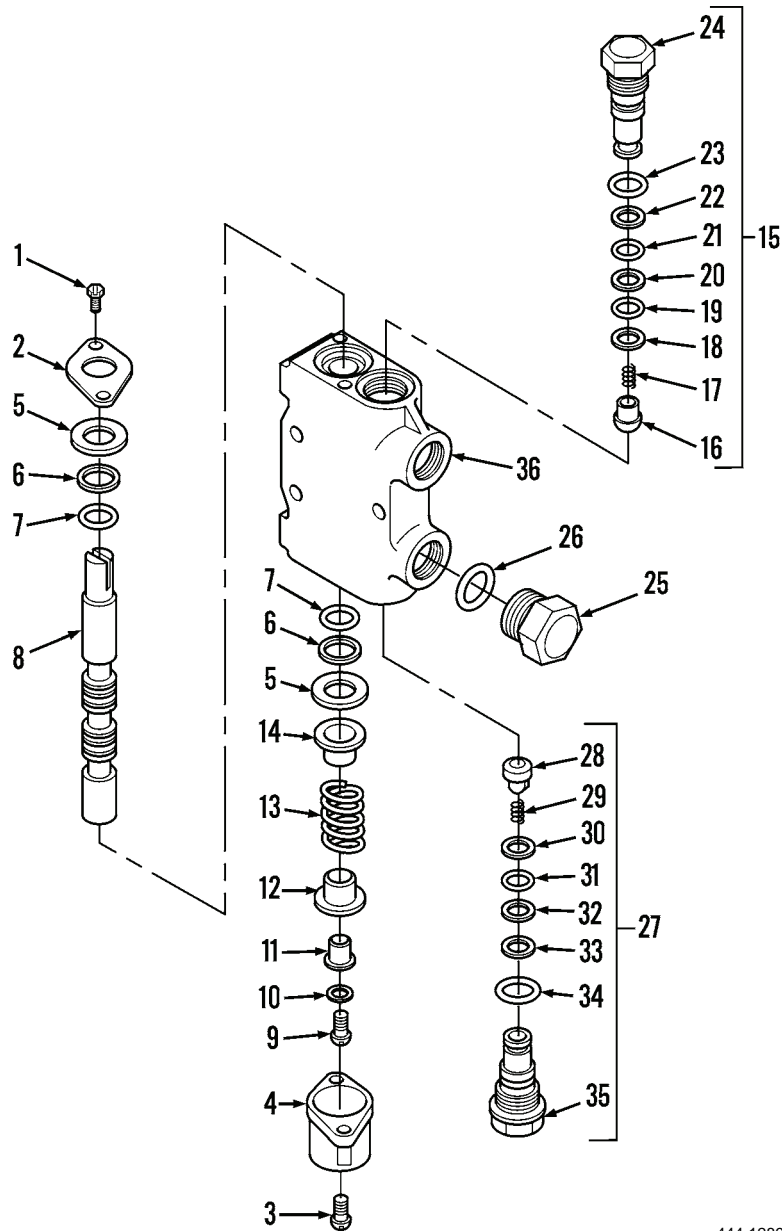

444-1289

**Figure 7. Lift Valve Assembly.**



**LIFT VALVE SECTION DISASSEMBLY - CONTINUED**

4. Remove bonnet (Figure 7, Item 4) from housing (Figure 7, Item 36).
5. Remove spool (Figure 7, Item 8) from housing (Figure 7, Item 36). Use rod inserted in pin hole to remove. Do not use wrench or pliers.
6. Remove two seal retainer plates (Figure 7, Item 5), back-up rings (Figure 7, Item 6), and O-rings (Figure 7, Item 7) from spool (Figure 7, Item 8). Discard O-rings.
7. Remove screw (Figure 7, Item 9) and lockwasher (Figure 7, Item 10) from spool collar (Figure 7, Item 11). Discard lockwasher.
8. Remove spool collar (Figure 7, Item 11), spring collar (Figure 7, Item 12), return spring (Figure 7, Item 13), and spring collar (Figure 7, Item 14) from housing (Figure 7, Item 36).
9. Remove load check assembly (Figure 7, Item 15) from housing (Figure 7, Item 36).
10. Remove load check poppet (Figure 7, Item 16), poppet spring (Figure 7, Item 17), back-up rings (Figure 7, Items 18, 20, and 22), and O-rings (Figure 7, Items 19, 21, and 23) from check plug (Figure 7, Item 24). Discard O-rings.
11. Remove plug (Figure 7, Item 25) and O-ring (Figure 7, Item 26) from housing (Figure 7, Item 36). Discard O-ring.
12. Remove conversion plug assembly (Figure 7, Item 27) from housing (Figure 7, Item 36).
13. Remove plug (Figure 7, Item 28), back-up rings (Figure 7, Items 29, 31, and 33), and O-rings (Figure 7, Items 30, 32, and 34) from check plug (Figure 7, Item 35). Discard O-rings.

**END OF TASK****CLEANING****WARNING**

Solvent cleaning compound MIL-PRF-680 Type III is an environmentally compliant and low toxic material. However, it may be irritating to the eyes and skin. Use protective gloves and goggles. Use in well-ventilated areas. Keep away from open flames and other sources of ignition. Failure to do so may result in injury or death to personnel.

Use solvent cleaning compound to clean all parts. Dry thoroughly. Be sure bores in housings are thoroughly clean.

**END OF TASK****INSPECTION/REPAIR**

1. Inspect springs. Replace if distorted, cracked, or fatigue signs are evident.
2. Inspect spools. Replace if finish is damaged or if bent or damaged.
3. Inspect screws and plugs. Replace if threads damaged in any way, or corroded.
4. Inspect housings. Replace if bores damaged, cracked, internal threads damaged, or internal wear is evident.
5. Inspect all other parts. Replace if damaged, cracked, or distorted.

**END OF TASK**

**LEFT COVER PLATE ASSEMBLY****NOTE**

Lubricate all O-rings with clean lubricating oil before reassembly.

1. Install new O-ring (Figure 8, Item 5), back-up washer (Figure 8, Item 4), new O-ring (Figure 8, Item 3), and back-up washer (Figure 8, Item 2) on relief plug (Figure 8, Item 6).
2. Install two new O-rings (Figure 8, Item 8) on plugs (Figure 8, Item 7).
3. Install relief plug assembly (Figure 8, Item 1) in left cover plate (Figure 8, Item 9).
4. Install two plugs (Figure 8, Item 7) with new O-rings (Figure 8, Item 8) in left cover plate (Figure 8, Item 9).

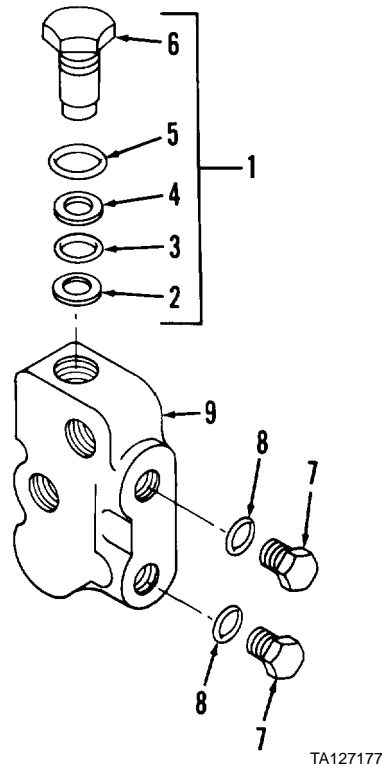

**Figure 8. Cover Plate Assembly.**

**END OF TASK****ROTATE, SIDESHIFT, AND TILT VALVE SECTIONS ASSEMBLY**

1. Install two new O-rings (Figure 9, Item 23) on check plugs (Figure 9, Item 24).
2. Install six back-up rings (Figure 9, Items 22, 20, and 18), four new O-rings (Figure 9, Items 21 and 19), two poppet springs (Figure 9, Item 17), and two load check poppets (Figure 9, Item 16).
3. Install two check plug assemblies (Figure 9, Item 15) onto top and bottom of housing (Figure 9, Item 25).
4. Install two new O-rings (Figure 9, Item 7) on spool (Figure 9, Item 8).
5. Install two back-up rings (Figure 9, Item 6) and seal retainer plates (Figure 9, Item 5) on spool (Figure 9, Item 8).
6. Install spool (Figure 9, Item 8) in bore on top of housing (Figure 9, Item 25).
7. Position seal plate (Figure 9, Item 2) in housing (Figure 9, Item 25).
8. Install two screws (Figure 9, Item 1) on seal plate (Figure 9, Item 2) and tighten.

**ROTATE, SIDESHIFT, AND TILT VALVE SECTIONS ASSEMBLY - CONTINUED**

9. Install spring collar (Figure 9, Item 14), return spring (Figure 9, Item 13), and spool collar (Figure 9, Item 11) on bottom of housing (Figure 9, Item 25).
10. Install new lockwasher (Figure 9, Item 10) and screw (Figure 9, Item 9) on spool collar (Figure 9, Item 11).
11. Position bonnet (Figure 9, Item 4) and install two screws (Figure 9, Item 3) in bonnet.

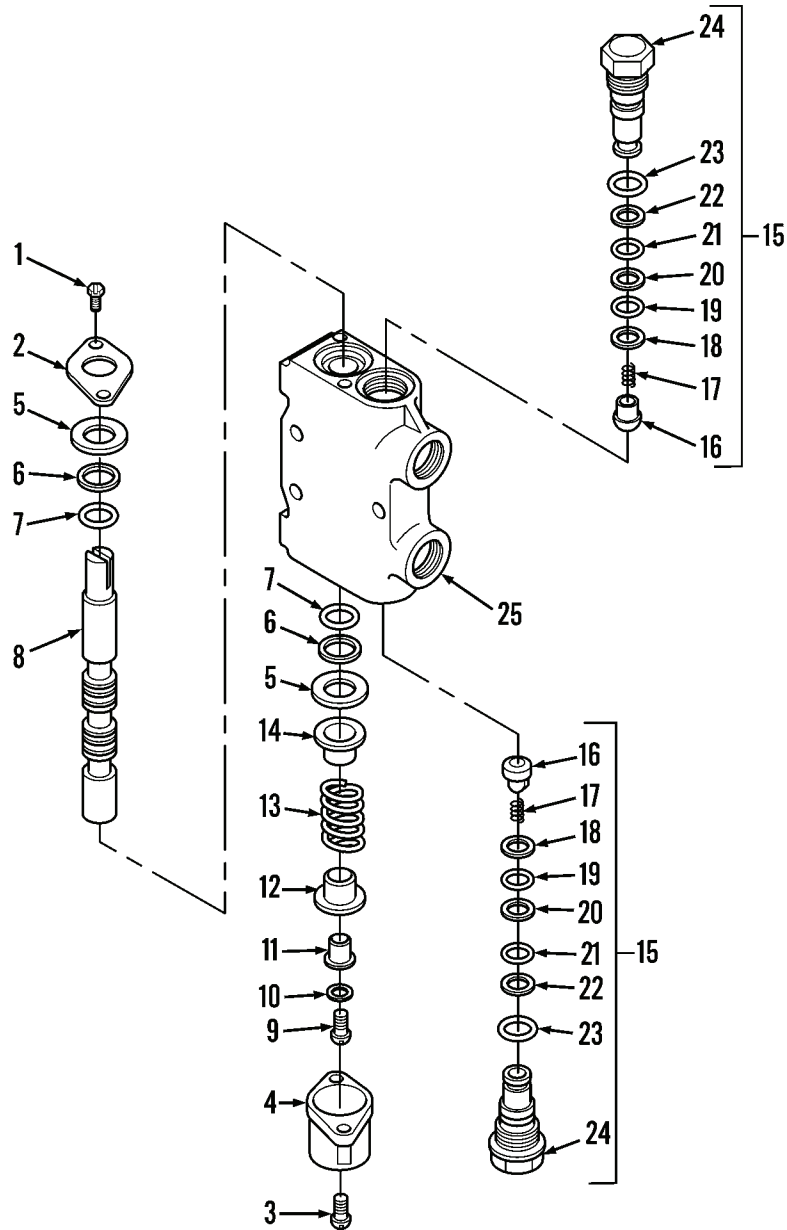

444-1288

**Figure 9. Rotate, Sideshift, and Tilt Valve Sections.**

**END OF TASK**

---

**LIFT VALVE SECTION ASSEMBLY**

1. Install new O-ring (Figure 10, Item 34) on check plug (Figure 10, Item 35).
2. Install back-up rings (Figure 10, Items 33, 31, and 29), new O-rings (Figure 10, Items 32 and 30), and plug (Figure 10, Item 28) on check plug (Figure 10, Item 35).
3. Install conversion plug assembly (Figure 10, Item 27) in bottom of housing (Figure 10, Item 36).
4. Position new O-ring (Figure 10, Item 26) on plug (Figure 10, Item 25) and install plug on housing (Figure 10, Item 36).
5. Install new O-ring (Figure 10, Item 23) on check plug (Figure 10, Item 24).
6. Install back-up rings (Figure 10, Items 22, 20, and 18), new O-rings (Figure 10, Items 21 and 19), poppet spring (Figure 10, Item 17), and load check poppet (Figure 10, Item 16) on check plug (Figure 10, Item 24).
7. Install load check plug assembly (Figure 10, Item 15) on top of housing (Figure 10, Item 36).
8. Install two new O-rings (Figure 10, Item 7), back-up rings (Figure 10, Item 6), and seal retainer plates (Figure 10, Item 5) on spool (Figure 10, Item 8).
9. Install spool (Figure 10, Item 8) on top of housing (Figure 10, Item 36).
10. Position seal plate (Figure 10, Item 2) on housing (Figure 10, Item 36) and install two screws (Figure 10, Item 1).
11. Install spring collar (Figure 10, Item 14), return spring (Figure 10, Item 13), spring collar (Figure 10, Item 12), and spool collar (Figure 10, Item 11) in bottom of housing (Figure 10, Item 36).
12. Install new lockwasher (Figure 10, Item 10) and screw (Figure 10, Item 9) on spool collar (Figure 10, Item 11).
13. Position bonnet (Figure 10, Item 4) on housing (Figure 10, Item 36) and install two screws (Figure 10, Item 3).

LIFT VALVE SECTION ASSEMBLY - CONTINUED

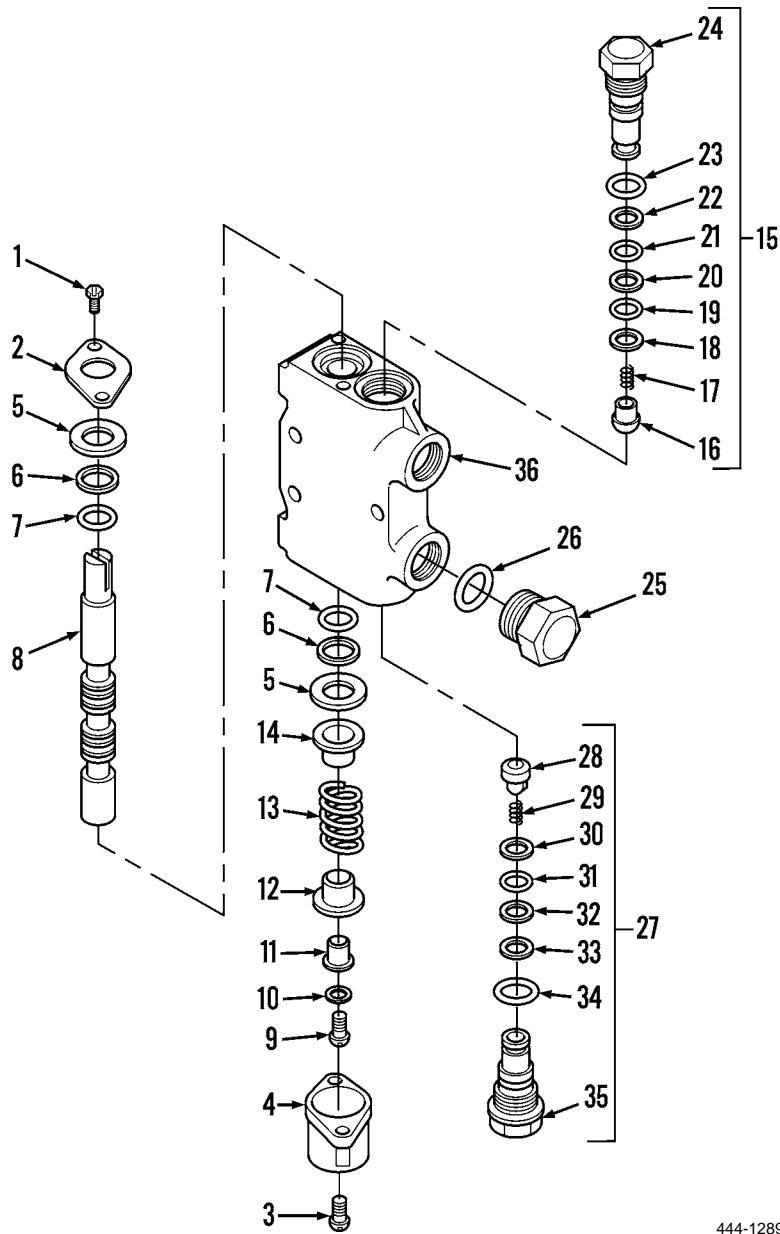

444-1289

Figure 10. Lift Valve Assembly.

END OF TASK

**FINAL ASSEMBLY**

1. Install three capscrews (Figure 11, Item 8) in left cover plate (Figure 11, Item 10).
2. Position new O-rings (Figure 11, Items 3 and 4) in cover plate (Figure 11, Item 10) bores.
3. Position rotate valve section (Figure 11, Item 9) on cover plate.
4. Position new O-rings (Figure 11, Items 3 and 4) in bores of rotate valve section (Figure 11, Item 9).
5. Position shift valve section (Figure 11, Item 7) on bores of rotate valve section (Figure 11, Item 9).
6. Position new O-rings (Figure 11, Items 3 and 4) in bores of shift valve section (Figure 11, Item 7).
7. Position lift valve section (Figure 11, Item 6) on rotate valve section (Figure 11, Item 9).
8. Position new O-rings (Figure 11, Items 3 and 4) in bores of lift valve section (Figure 11, Item 6).
9. Position tilt valve section (Figure 11, Item 5) on lift valve section (Figure 11, Item 6).
10. Position new O-rings (Figure 11, Items 3 and 4) in bores of tilt valve section (Figure 11, Item 5).
11. Position right cover plate (Figure 11, Item 2) on tilt valve section (Figure 11, Item 5).
12. Install three nuts (Figure 11, Item 1) on right cover plate (Figure 11, Item 2) and tighten to 18 to 22 lb-ft (24 to 30 Nm).
13. Position new O-ring (Figure 11, Item 12) on plug (Figure 11, Item 11).
14. Install plug (Figure 11, Item 11) on right cover plate (Figure 11, Item 2).

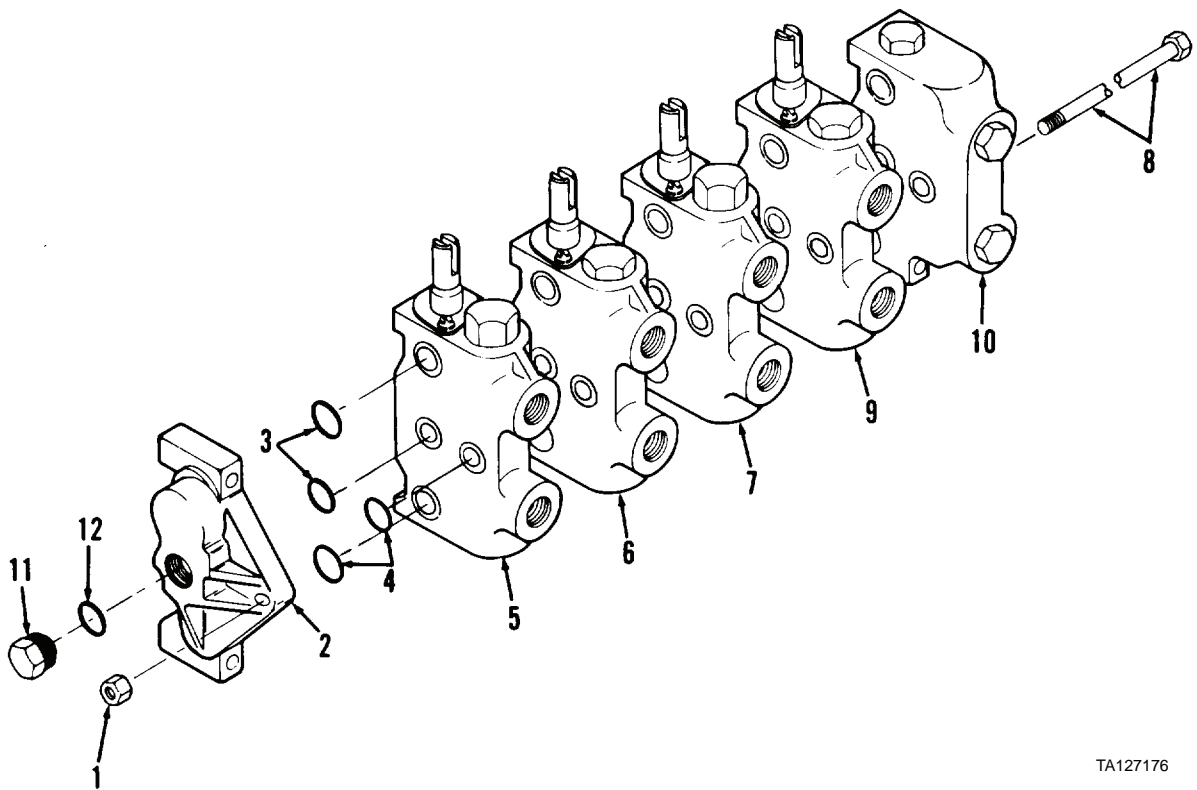

TA127176

Figure 11. Hydraulic Control Valve Assembly.

**END OF TASK**

**INSTALLATION/REPLACEMENT**

1. Position control valve (Figure 12, Item 10) on vehicle.
2. Install washer (Figure 12, Item 9) and capscrew (Figure 12, Item 8) on oil drip pan (Figure 12, Item 5). Position axle breather hose clamp on capscrew.
3. Install new lockwasher (Figure 12, Item 7) and nut (Figure 12, Item 6) on axle breather hose clamp and control valve (Figure 12, Item 10) and tighten nut.
4. Position oil drip pan (Figure 12, Item 5) on vehicle and install two washers (Figure 12, Item 4) and capscrews (Figure 12, Item 3).
5. Install two new lockwashers (Figure 12, Item 2) and nuts (Figure 12, Item 1) on capscrew (Figure 12, Item 3) and tighten nut.

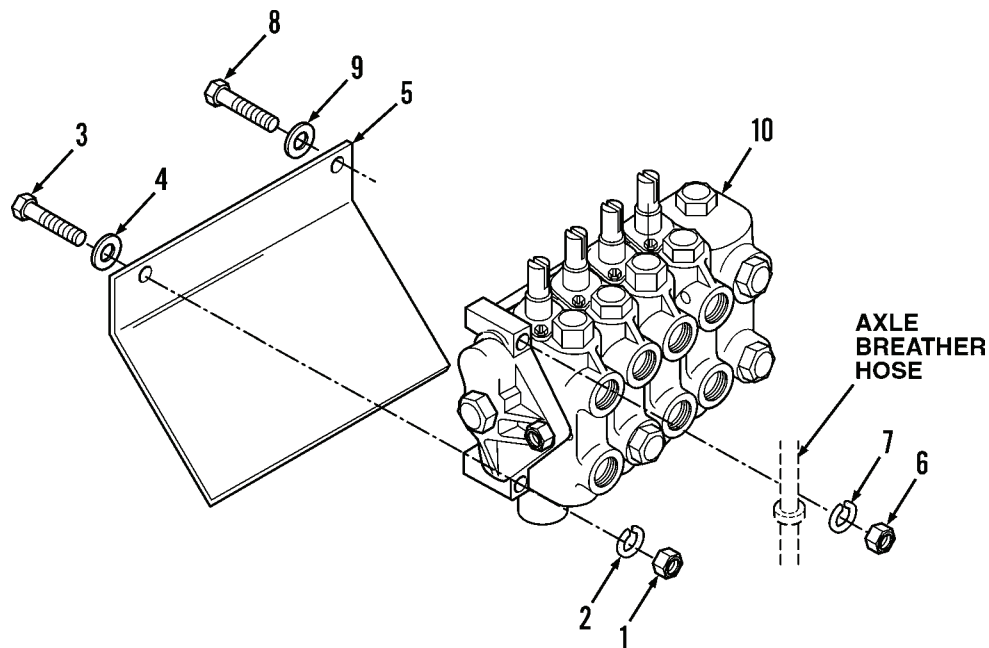

444-1285

**Figure 12. Hydraulic Control Valve and Associated Parts.**

6. Install adapter and connector (WP 0195, *Installation/Replacement*, steps 47 and 52).
7. Remove caps, connect to control valve, and tighten (WP 0195, *Installation/Replacement*, steps 49 and 54).
8. Connect control valve linkage (WP 0191, *Installation/Replacement*, step 16).
9. Install elbows and hose fittings on control valve and tighten (WP 0195, *Installation/Replacement*, steps 39 through 46).
10. Fill hydraulic reservoir with hydraulic oil (WP 0198).
11. Perform WP 0195, *Bleeding Air from Lift Assembly*, steps 1 through 6.

**END OF TASK****END OF WORK PACKAGE**





# DIRECT SUPPORT MAINTENANCE INSTRUCTIONS

## TILT CYLINDERS MAINTENANCE

Removal, Disassembly, Cleaning, Inspection/Repair, Assembly, Installation/Replacement

### INITIAL SETUP

#### Maintenance Level

Direct Support

#### Tools and Special Tools

Tool kit, general mechanic's (Item 15, WP 0309)  
Shop equipment, common no. 1 (Item 2, WP 0309)  
Sleeve, 1-1/2 in. diameter  
Sleeve, 1-9/16 in. diameter

#### Materials/Parts

Cap set, protective (Item 9, WP 0310)  
Cleaning compound, solvent (Item 10, WP 0310)  
Lubricating oil, OE/HDO-10 (Item 20, WP 0310)  
Rag, wiping (Item 26, WP 0310)  
Tag, marker (Item 33, WP 0310)  
Back-up ring  
Bearing  
Emery cloth, medium grit  
Lockwasher

#### Materials/Parts - Continued

O-ring  
Retaining ring  
Seal (2)  
Seal loader ring  
Wear ring (2)  
Wiper

#### References

LO 10-3930-638-12  
WP 0196  
WP 0197

#### Equipment Condition

Vehicle parked on level surface  
Engine OFF  
Parking brake applied  
Mast vertical  
Forks lowered and resting on ground  
Control valve control levers operated several times  
to relieve hydraulic pressure



### WARNING

If both tilt cylinder assemblies are to be removed, support mast assembly using chain hoist attached to top of mast assembly. Failure to do so may cause mast assembly to fall forward, striking personnel standing/working in front of unit. This could cause injury or death to personnel.

**REMOVAL****WARNING**

Solvent cleaning compound MIL-PRF-680 Type III is an environmentally compliant and low toxic material. However, it may be irritating to the eyes and skin. Use protective gloves and goggles. Use in well-ventilated areas. Keep away from open flames and other sources of ignition. Failure to do so may result in injury or death to personnel.

**NOTE**

Cap all hoses, lines, fittings, and openings.

1. Disconnect hose fittings (Figure 1, Items 1 and 2). Use clean rag moistened with solvent cleaning compound to clean fitting.
2. Remove adapter (Figure 1, Item 3) from cylinder (Figure 1, Item 33).
3. Remove elbow (Figure 1, Item 4) from cylinder (Figure 1, Item 33).
4. Remove two retaining rings (Figure 1, Item 5) from rod (Figure 1, Item 31).
5. Remove pin (Figure 1, Item 6) from rod (Figure 1, Item 31).
6. Remove nut (Figure 1, Item 7), lockwasher (Figure 1, Item 8), capscrew (Figure 1, Item 9), and rod (Figure 1, Item 10) from mounting bracket. Discard lockwasher.
7. Remove pin (Figure 1, Item 11) from cylinder (Figure 1, Item 33).
8. Remove tilt cylinder assembly (Figure 1, Item 12) from vehicle.

REMOVAL - CONTINUED

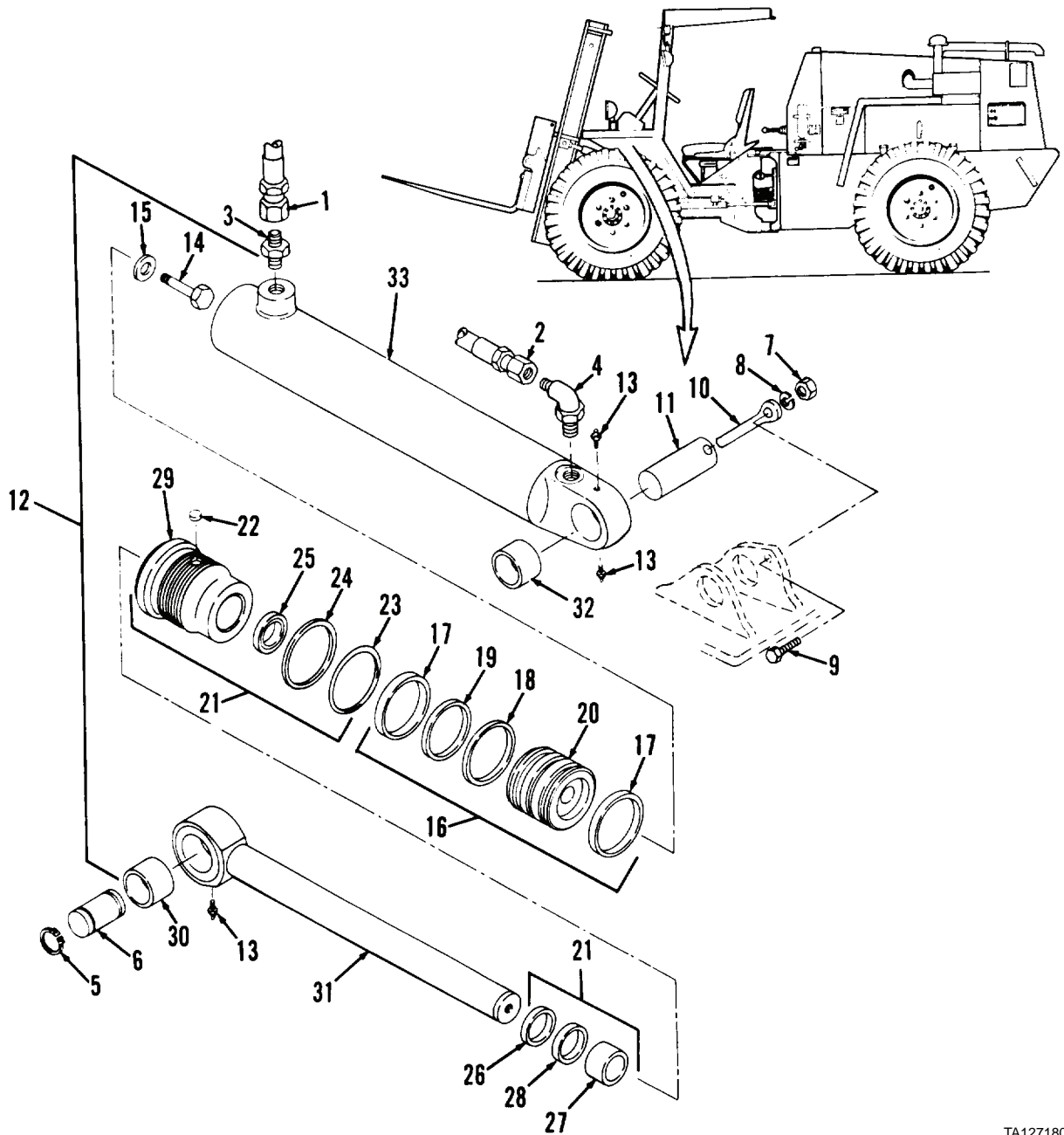

Figure 1. Tilt Cylinder and Associated Parts.

TA127180

END OF TASK

**DISASSEMBLY****WARNING**

Solvent cleaning compound MIL-PRF-680 Type III is an environmentally compliant and low toxic material. However, it may be irritating to the eyes and skin. Use protective gloves and goggles. Use in well-ventilated areas. Keep away from open flames and other sources of ignition. Failure to do so may result in injury or death to personnel.

1. Use solvent cleaning compound and clean all exterior surfaces of tilt cylinder assembly (Figure 2, Item 12).
2. Remove three lubrication fittings (Figure 2, Item 13) from cylinder (Figure 2, Item 33) and rod (Figure 2, Item 31).
3. Loosen gland assembly (Figure 2, Item 21).
4. Remove rod (Figure 2, Item 31), gland assembly (Figure 2, Item 21), and piston assembly (Figure 2, Item 16) as an assembly from tilt cylinder assembly (Figure 2, Item 12).
5. Remove capscrew (Figure 2, Item 14) and washer (Figure 2, Item 15) from rod (Figure 2, Item 31).
6. Remove piston assembly (Figure 2, Item 16) from tilt cylinder assembly (Figure 2, Item 12).
7. Remove gland assembly (Figure 2, Item 21) from tilt cylinder assembly (Figure 2, Item 12).
8. Remove two wear rings (Figure 2, Item 17) from piston assembly (Figure 2, Item 16) and discard.
9. Remove seal (Figure 2, Item 18) from piston assembly (Figure 2, Item 16) and discard.
10. Remove seal loader ring (Figure 2, Item 19) from piston assembly (Figure 2, Item 16) and discard.
11. Remove plug (Figure 2, Item 22) from gland (Figure 2, Item 29).
12. Remove O-ring (Figure 2, Item 23) from gland assembly (Figure 2, Item 21) and discard.
13. Remove back-up ring (Figure 2, Item 24) from gland assembly (Figure 2, Item 21) and discard.
14. Remove seal (Figure 2, Item 25) from gland assembly (Figure 2, Item 21) and discard.
15. Remove wiper (Figure 2, Item 26) from gland assembly (Figure 2, Item 21) and discard.

**NOTE**

Use 1-1/2-in. diameter sleeve; remove from rod end. Bearing and retaining ring will both be removed.

16. Remove bearing (Figure 2, Item 27) from gland assembly (Figure 2, Item 21) and discard.
17. Remove retaining ring (Figure 2, Item 28) from gland assembly (Figure 2, Item 21) and discard.
18. Use 1-9/16 in. diameter sleeve to remove bushing (Figure 2, Item 30) from rod (Figure 2, Item 31).
19. Use 1-9/16 in. diameter sleeve to remove bushing (Figure 2, Item 32) from cylinder (Figure 2, Item 33).

DISASSEMBLY - CONTINUED

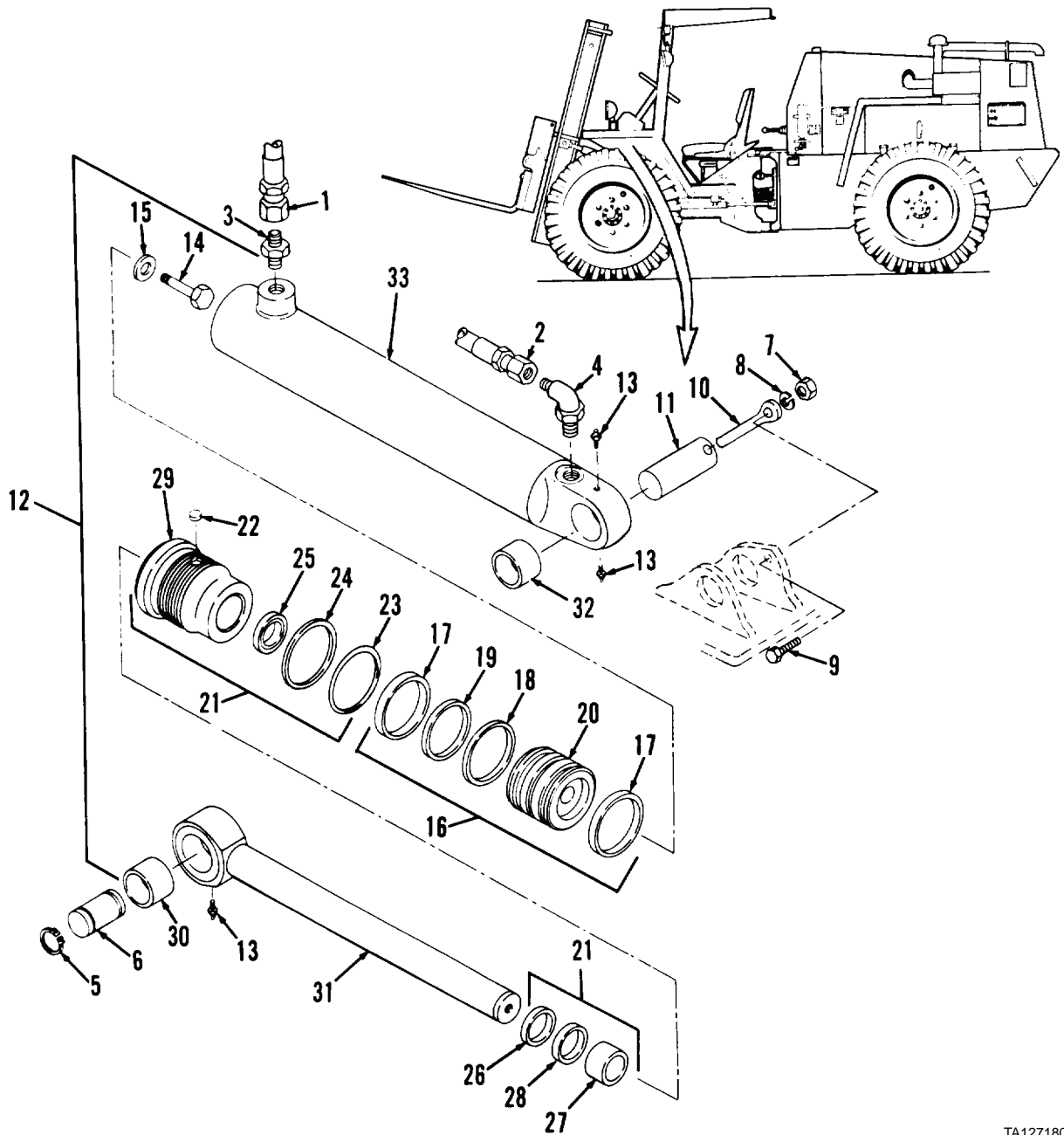

TA127180

Figure 2. Tilt Cylinder and Associated Parts.

END OF TASK

**CLEANING****WARNING**

- Solvent cleaning compound MIL-PRF-680 Type III is an environmentally compliant and low toxic material. However, it may be irritating to the eyes and skin. Use protective gloves and goggles. Use in well-ventilated areas. Keep away from open flames and other sources of ignition. Failure to do so may result in injury or death to personnel.
- Particles blown by compressed air are hazardous. DO NOT exceed 15 PSI (103 kPa) nozzle pressure when drying parts with compressed air. DO NOT direct compressed air against human skin. xMake sure air stream is directed away from user and other personnel in the area. To prevent injury, user must wear protective goggles or face shield. Failure to follow this warning may result in injury to personnel.

Use solvent cleaning compound to clean all parts. Dry with compressed air.

**END OF TASK****INSPECTION/REPAIR**

1. Inspect rod (Figure 3, Item 31). Replace if bent, deeply grooved, or scored. Remove nicks or scratches with medium-grit emery cloth polishing with a rotary motion.
2. Inspect cylinder (Figure 3, Item 33). Replace if deeply grooved, scored, or damaged. Remove nicks or scratches with medium-grit emery cloth polishing with a rotary motion.
3. Inspect bushing (Figure 3, Items 30 and 32). Replace if worn, cracked, or split.
4. Inspect all other parts. Replace if damaged, cracked, split, grooved, or scored.

INSPECTION/REPAIR - CONTINUED

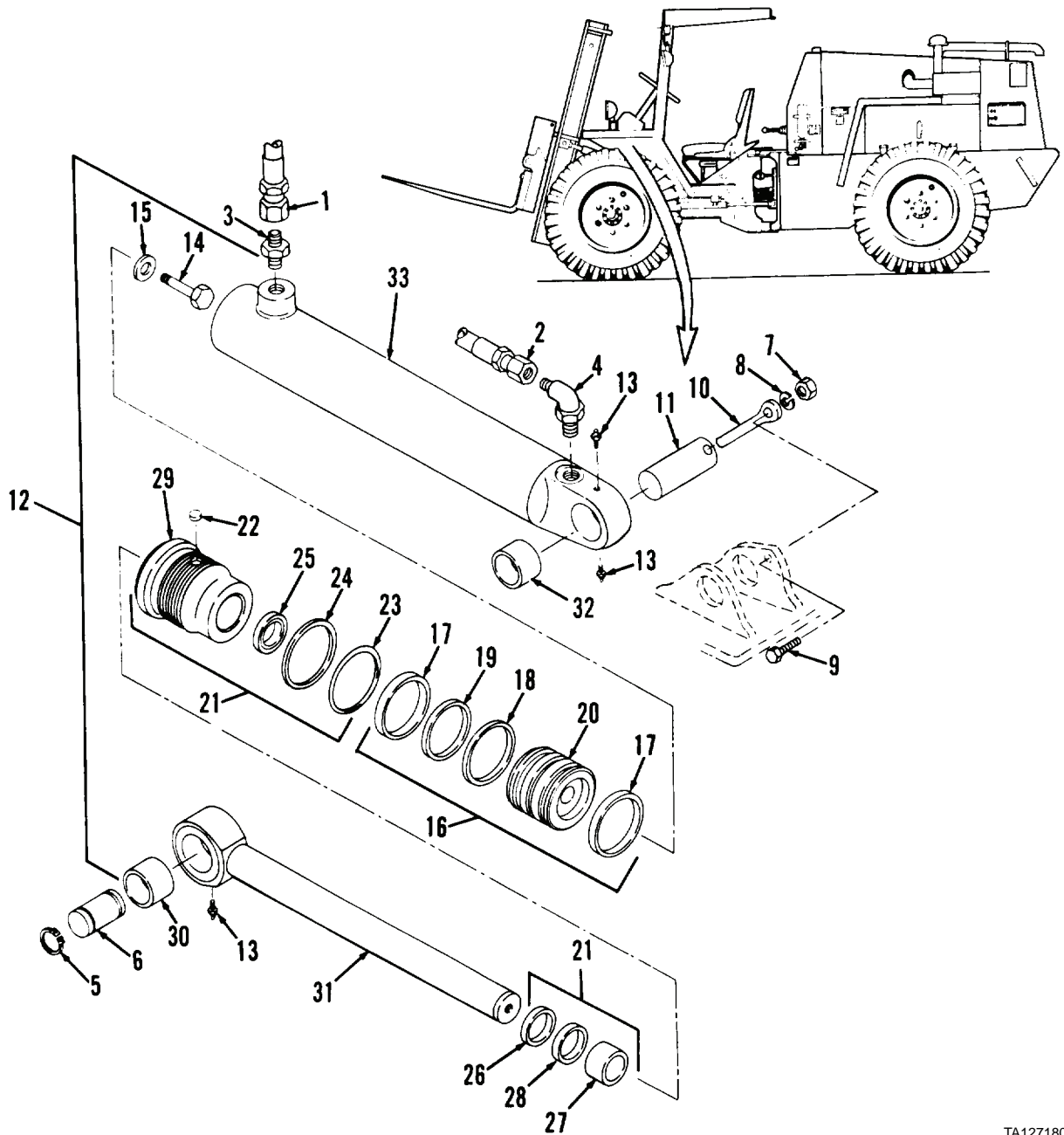

Figure 3. Tilt Cylinder and Associated Parts.

TA127180

END OF TASK

**ASSEMBLY**

1. Use 1-9/16-in. diameter sleeve to install bushing (Figure 4, Item 32) in cylinder (Figure 4, Item 33) until flush.
2. Use 1-9/16-in. diameter sleeve to install bushing (Figure 4, Item 30) in rod (Figure 4, Item 31) until flush.
3. Install new bearing (Figure 4, Item 27) on gland (Figure 4, Item 29) from rod end until bearing butt rests against shoulder of gland (Figure 4, Item 29).
4. Install new retaining ring (Figure 4, Item 28) on gland (Figure 4, Item 29) from rod end, chamfer towards bearing (Figure 4, Item 27), until butt rests against shoulder of gland (Figure 4, Item 27).
5. Install new wiper (Figure 4, Item 26) on gland (Figure 4, Item 29) with grooved side towards rod end.
6. Install new seal (Figure 4, Item 25) on gland (Figure 4, Item 29) with seal lip towards cylinder.
7. Install new back-up ring (Figure 4, Item 24) on gland (Figure 4, Item 29) with curved side towards O-ring (Figure 4, Item 23).
8. Install new O-ring (Figure 4, Item 23) on gland (Figure 4, Item 29).
9. Install plug (Figure 4, Item 22) on gland (Figure 4, Item 29).
10. Install new seal loader ring (Figure 4, Item 19) on piston (Figure 4, Item 20).
11. Install new seal (Figure 4, Item 18) on seal loader ring (Figure 4, Item 19).
12. Install two new wear rings (Figure 4, Item 17) on piston (Figure 4, Item 20).

**CAUTION**

Use extreme caution when performing step 13 not to damage wiper, seal, back-up rings, or O-ring.

13. Use clean lubricating oil to lubricate gland assembly (Figure 4, Item 21) and slide on rod (Figure 4, Item 31).
14. Slide small diameter recess towards rod (Figure 4, Item 31) and install rod on piston assembly (Figure 4, Item 16).
15. Install washer (Figure 4, Item 15) and capscrew (Figure 4, Item 14) on rod (Figure 4, Item 31). Tighten capscrew to 200 to 220 lb-ft (271 to 298 Nm).
16. Use clean lubricating oil to lubricate seal (Figure 4, Item 18).

**CAUTION**

Use extreme caution not to damage rings or seals when performing step 17.

17. Install rod (Figure 4, Item 31), gland assembly (Figure 4, Item 21), and piston assembly (Figure 4, Item 16) as an assembly on cylinder (Figure 4, Item 33).
18. Position gland assembly (Figure 4, Item 21) on rod (Figure 4, Item 31) and tighten to 150 to 200 lb-ft (203 to 271 Nm).
19. Install three lubrication fittings (Figure 4, Item 13) on cylinder (Figure 4, Item 33) and rod (Figure 4, Item 31).

**END OF TASK****INSTALLATION/REPLACEMENT**

1. Position tilt cylinder assembly (Figure 4, Item 12) on vehicle.
2. Install pin (Figure 4, Item 11) on cylinder (Figure 4, Item 33).
3. Install rod (Figure 4, Item 10) in tilt cylinder assembly (Figure 4, Item 12).
4. Install capscrew (Figure 4, Item 9), new lockwasher (Figure 4, Item 8), and nut (Figure 4, Item 7) on mounting bracket.
5. Install pin (Figure 4, Item 6) on rod (Figure 4, Item 31).
6. Install two retaining rings (Figure 4, Item 5) in rod (Figure 4, Item 31).
7. Install elbow (Figure 4, Item 4) on cylinder (Figure 4, Item 33).
8. Install adapter (Figure 4, Item 3) on cylinder (Figure 4, Item 33).
9. Tighten hose fittings (Figure 4, Items 1 and 2).



**INSTALLATION/REPLACEMENT - CONTINUED**

10. Perform WP 0196 or WP 0197, *Installation*, step 12.

11. Lubricate three lubrication fittings (Figure 4, Item 13) on tilt cylinder assembly (Figure 4, Item 12). Refer to LO 10-3930-638-12.

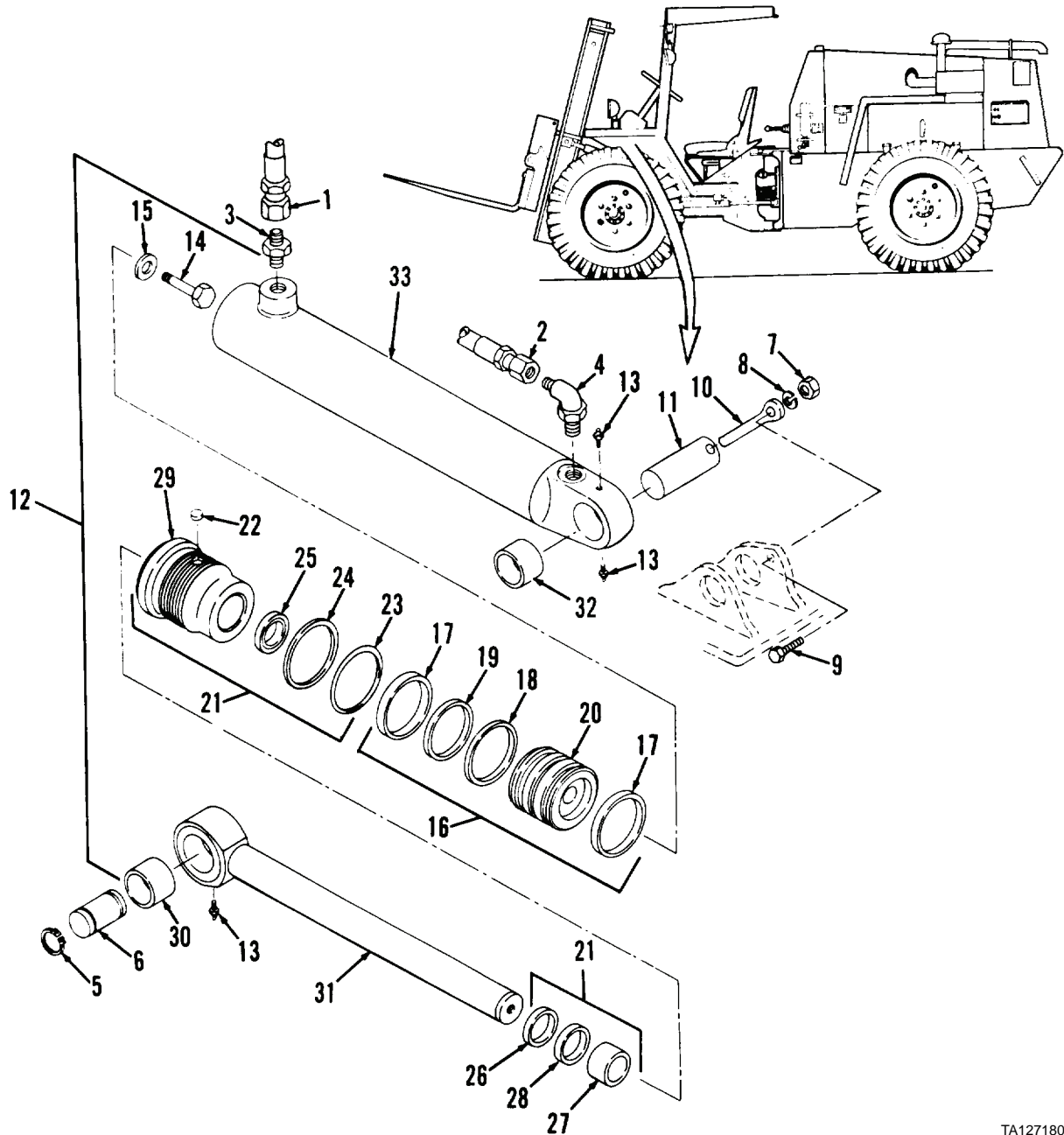

**Figure 4. Tilt Cylinder and Associated Parts.**

TA127180

**END OF TASK**

**END OF WORK PACKAGE**



---

## DIRECT SUPPORT MAINTENANCE INSTRUCTIONS

### SIDESHIFT CYLINDER MAINTENANCE

Removal, Disassembly, Cleaning, Inspection/Repair, Assembly, Testing, Installation/Replacement

---

#### INITIAL SETUP

##### Maintenance Level

Direct Support

##### Tools and Special Tools

Tool kit, general mechanic's (Item 15, WP 0309)  
 Shop equipment, common no. 1 (Item 2, WP 0309)  
 Hydraulic pump (used for testing)

##### Materials/Parts

Cap set, protective (Item 9, WP 0310)  
 Cleaning compound, solvent (Item 10, WP 0310)  
 Lubricating oil, OE/HDO-10 (Item 20, WP 0310)  
 Rag, wiping (Item 26, WP 0310)  
 Back-up ring  
 Emery cloth, medium grit  
 Lockwasher (2)  
 O-ring  
 Seal (2)

##### Materials/Parts - Continued

Seal loader ring  
 Wear ring (2)  
 Wiper

##### References

WP 0196  
 WP 0197

##### Equipment Condition

Vehicle parked on level surface  
 Engine OFF  
 Parking brake applied  
 Mast vertical  
 Forks lowered and resting on ground  
 Control valve control levers operated several times  
 to relieve hydraulic pressure  
 Forks shifted to extreme right  
 One end of sideshift chains disconnected from carriage and pulleys removed from sideshift cylinder (WP 0194)

---

**REMOVAL**

Solvent cleaning compound MIL-PRF-680 Type III is an environmentally compliant and low toxic material. However, it may be irritating to the eyes and skin. Use protective gloves and goggles. Use in well-ventilated areas. Keep away from open flames and other sources of ignition. Failure to do so may result in injury or death to personnel.

1. Disconnect hose fittings (Figure 1, Items 1 and 2) and clean with rag moistened with solvent cleaning compound.
2. Remove two 90 degree fittings (Figure 1, Item 3) from sideshift cylinder assembly (Figure 1, Item 11).
3. Remove nut (Figure 1, Item 4), washer (Figure 1, Item 5), and retaining ring (Figure 1, Item 6) from pin (Figure 1, Item 7).
4. Remove pin (Figure 1, Item 7) from sideshift cylinder assembly (Figure 1, Item 11).

**CAUTION**

Support sideshift cylinder assembly while performing step 5 to prevent it from falling.

5. Remove two capscrews (Figure 1, Item 8) and lockwashers (Figure 1, Item 9) from cylinder mounting strap (Figure 1, Item 10). Discard lockwashers.
6. Remove cylinder mounting strap (Figure 1, Item 10) from carriage assembly.
7. Remove sideshift cylinder assembly (Figure 1, Item 11) by pulling out from side of carriage assembly.

**END OF TASK****DISASSEMBLY**

Solvent cleaning compound MIL-PRF-680 Type III is an environmentally compliant and low toxic material. However, it may be irritating to the eyes and skin. Use protective gloves and goggles. Use in well-ventilated areas. Keep away from open flames and other sources of ignition. Failure to do so may result in injury or death to personnel.

1. Use solvent cleaning compound to clean all exterior surfaces of sideshift cylinder assembly (Figure 1, Item 11).
2. Loosen gland assembly (Figure 1, Item 19).
3. Remove rod (Figure 1, Item 26), gland assembly (Figure 1, Item 19), and piston assembly (Figure 1, Item 14) as an assembly from sideshift cylinder assembly (Figure 1, Item 11).
4. Remove capscrew (Figure 1, Item 12) and washer (Figure 1, Item 13) from rod (Figure 1, Item 26).
5. Remove piston assembly (Figure 1, Item 14) from rod (Figure 1, Item 26).
6. Remove gland assembly (Figure 1, Item 19) from rod (Figure 1, Item 26).
7. Remove two wear rings (Figure 1, Item 15) from piston assembly (Figure 1, Item 14) and discard.
8. Remove seal (Figure 1, Item 16) from piston assembly (Figure 1, Item 14) and discard.
9. Remove seal loader ring (Figure 1, Item 17) from piston assembly (Figure 1, Item 14) and discard.

DISASSEMBLY - CONTINUED

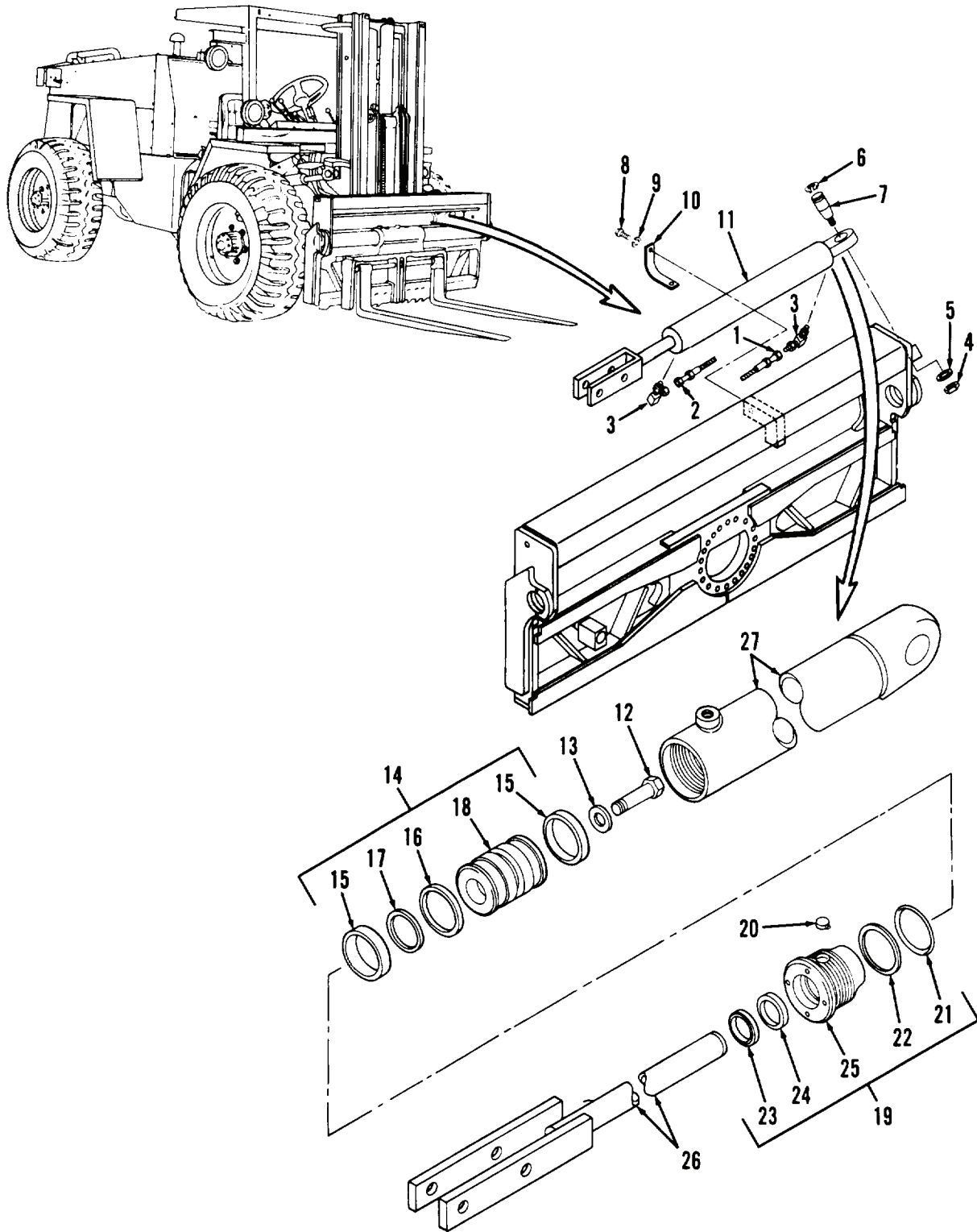

Figure 1. Sideshift Cylinder.

TA127181

**DISASSEMBLY - CONTINUED**

10. Remove plug (Figure 2, Item 20) from gland assembly (Figure 2, Item 19).
11. Remove O-ring (Figure 2, Item 21) from gland assembly (Figure 2, Item 19) and discard.
12. Remove back-up ring (Figure 2, Item 22) from gland assembly (Figure 2, Item 19) and discard.
13. Remove wiper (Figure 2, Item 23) from gland assembly (Figure 2, Item 19) and discard.
14. Remove seal (Figure 2, Item 24) from gland assembly (Figure 2, Item 19) and discard.

**END OF TASK****CLEANING****WARNING**

- Solvent cleaning compound MIL-PRF-680 Type III is an environmentally compliant and low toxic material. However, it may be irritating to the eyes and skin. Use protective gloves and goggles. Use in well-ventilated areas. Keep away from open flames and other sources of ignition. Failure to do so may result in injury or death to personnel.
- Particles blown by compressed air are hazardous. DO NOT exceed 15 PSI (103 kPa) nozzle pressure when drying parts with compressed air. DO NOT direct compressed air against human skin. Make sure air stream is directed away from user and other personnel in the area. To prevent injury, user must wear protective goggles or face shield. Failure to follow this warning may result in injury to personnel.

Use solvent cleaning compound to clean all parts. Dry with compressed air.

**END OF TASK****INSPECTION/REPAIR**

1. Inspect rod (Figure 2, Item 26). Replace if bent, deeply grooved, or scored. Remove nicks or scratches with medium-grit emery cloth polishing with a rotary motion
2. Inspect cylinder (Figure 2, Item 27). Replace if deeply grooved, scored, or damaged. Remove nicks or scratches with medium-grit emery cloth polishing with a rotary motion.
3. Inspect all other parts. Replace if damaged, cracked, split, grooved, or scored.

INSPECTION/REPAIR - CONTINUED

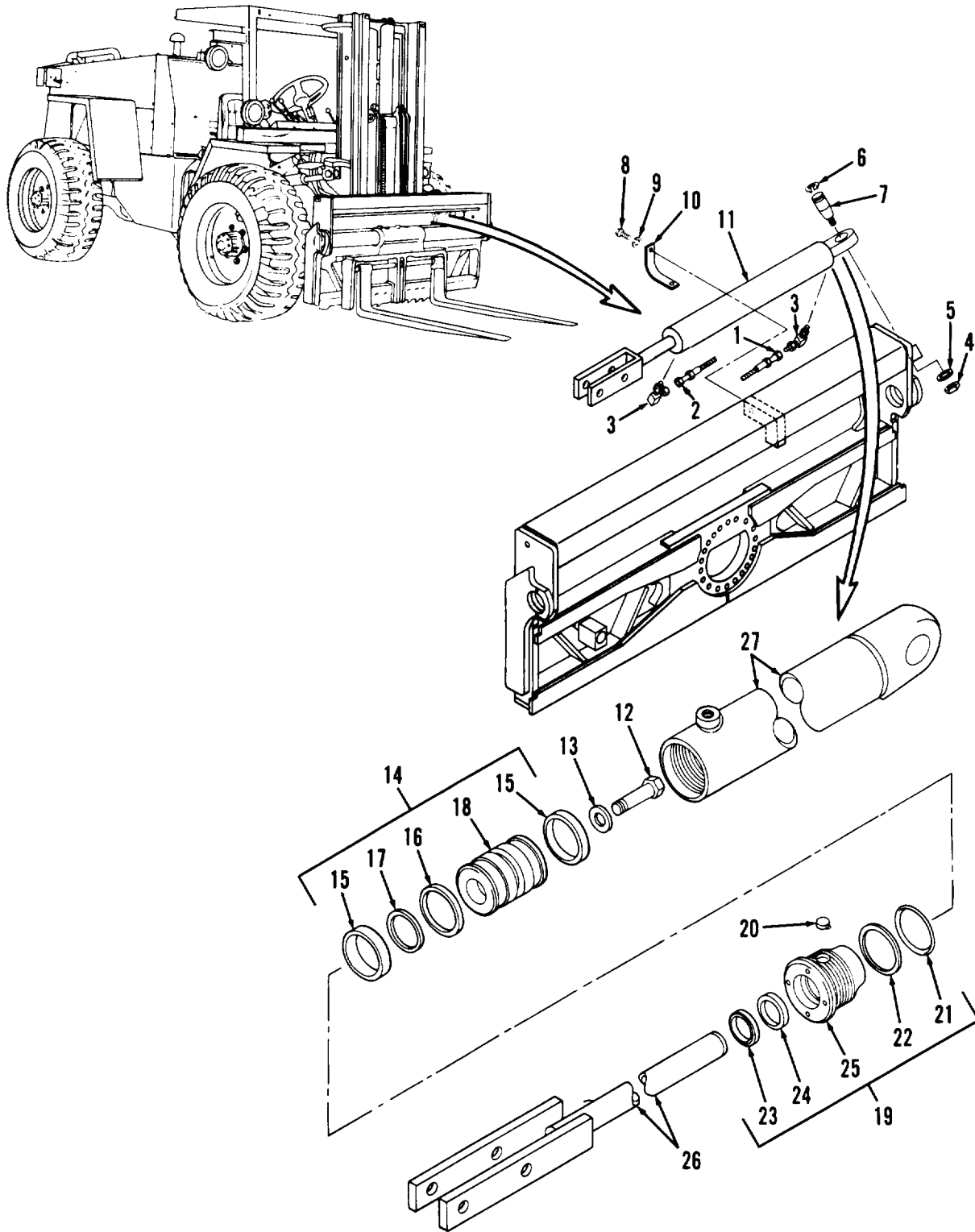

Figure 2. Sideshift Cylinder.

TA127181

END OF TASK

**ASSEMBLY**

1. Install new seal (Figure 3, Item 24) on gland (Figure 3, Item 25). Install with seal lip towards cylinder (Figure 3, Item 27).
2. Install new wiper (Figure 3, Item 23) on gland (Figure 3, Item 25). Install with lip towards rod (Figure 3, Item 26).
3. Install new back-up ring (Figure 3, Item 22) on gland (Figure 3, Item 25). Install with curved side towards O-ring (Figure 3, Item 21).
4. Install new O-ring (Figure 3, Item 21) on gland (Figure 3, Item 25).
5. Install plug (Figure 3, Item 20) on gland (Figure 3, Item 25).
6. Install new seal loader ring (Figure 3, Item 17) on piston (Figure 3, Item 18).
7. Install new seal (Figure 3, Item 16) on seal loader ring (Figure 3, Item 17).
8. Install two new wear rings (Figure 3, Item 15) on piston assembly (Figure 3, Item 14).

**CAUTION**

Take care when performing step 9 not to damage seal or wiper.

9. Use clean lubricating oil to lubricate gland assembly (Figure 3, Item 19) and install on rod (Figure 3, Item 26).
10. Install piston assembly (Figure 3, Item 14) on rod (Figure 3, Item 26) with small diameter recess towards rod.
11. Install washer (Figure 3, Item 13) and capscrew (Figure 3, Item 12) on rod (Figure 3, Item 26). Tighten capscrew to 200 to 220 lb-ft (271 to 298 Nm).
12. Use clean lubricating oil to lubricate new seal (Figure 3, Item 16).

**NOTE**

Use extreme caution not to damage rings or seals when performing step 13.

13. Install rod (Figure 3, Item 26), gland assembly (Figure 3, Item 19), and piston assembly (Figure 3, Item 14) on cylinder (Figure 3, Item 27) as an assembly.
14. Position gland assembly (Figure 3, Item 19) and tighten to 150 to 200 lb-ft (203 to 271 Nm).



ASSEMBLY - CONTINUED

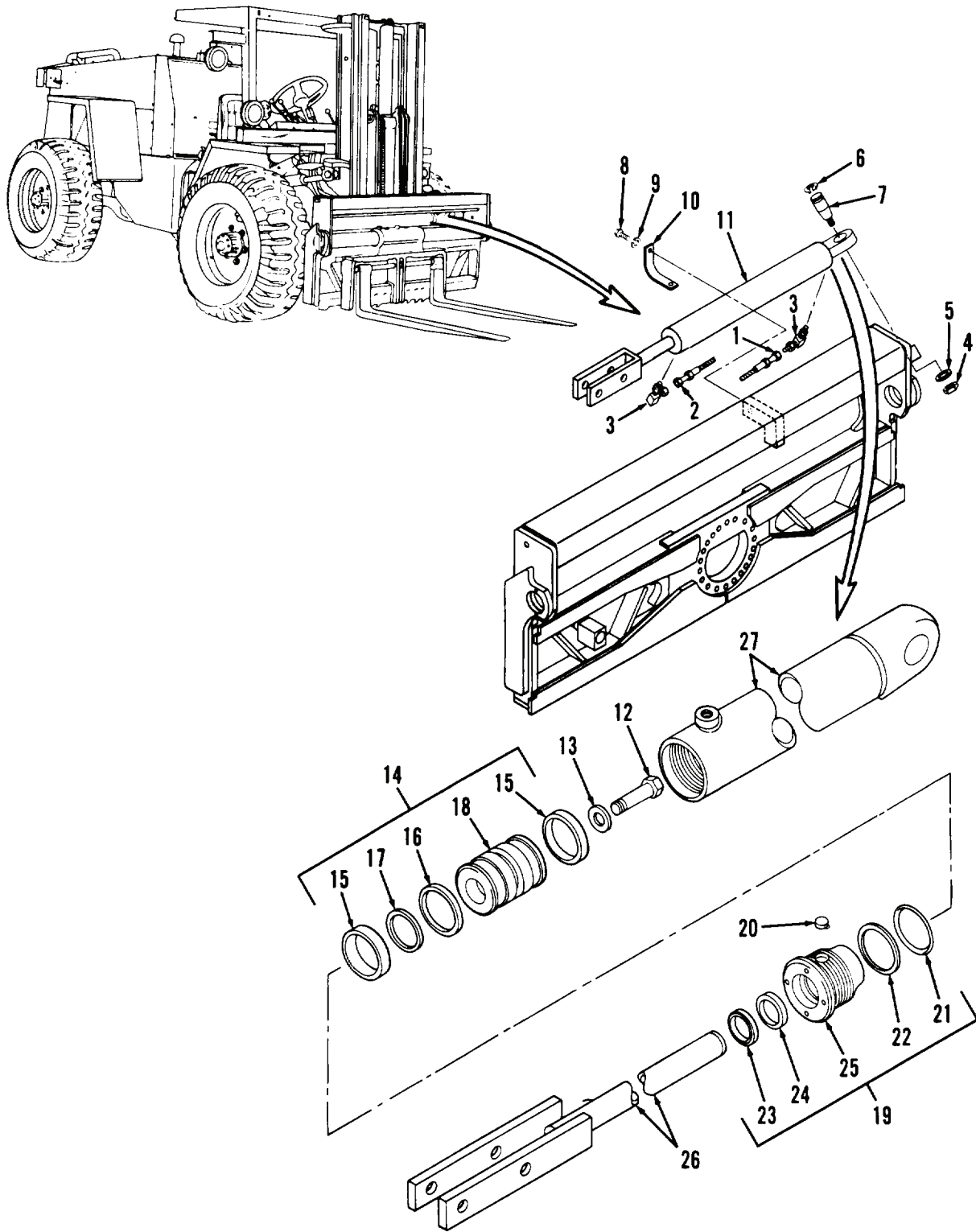

Figure 3. Sideshift Cylinder.

TA127181

END OF TASK

---

**TESTING**

1. Cylinder port (port opposite rod end):
  - a. Connect hydraulic hose to port (hose must have a 7/16-20 fitting on end).
  - b. Connect other end of hose to test hydraulic pump.
2. Test hydraulic pump:
  - a. Start pump. Rod should extend smoothly from cylinder. Apply hydraulic oil under pressure (2,000 PSI [13,789 kPa]) to sideshift cylinder assembly.
  - b. Continue operating pump until rod is completely extended from cylinder; hold until step 5 is completed.
3. Sideshift cylinder assembly:
  - a. Check rod end port for hydraulic oil leakage.
  - b. Slight leakage of oil is permissible; if leakage is too great, disassemble cylinder and check piston assembly (Figure 4, Item 14) for damage.
4. Rod end packing:
  - a. Check for hydraulic oil leakage.
  - b. If leakage is observed, disassemble cylinder and check piston assembly (Figure 4, Item 19) for damage.
5. Test hydraulic pump:

Shut pump down.
6. Sideshift cylinder assembly cylinder port (port opposite rod end):
  - a. Disconnect hydraulic hose and drain oil from cylinder.
  - b. Push rod into cylinder.
  - c. Cap both cylinder ports.

**END OF TASK****INSTALLATION/REPLACEMENT**

1. Position sideshift cylinder assembly (Figure 4, Item 11) on carriage.
2. Position cylinder mounting strap (Figure 4, Item 10) on carriage.
3. Install two capscrews (Figure 4, Item 8) and new lockwashers (Figure 4, Item 9) on cylinder mounting strap (Figure 4, Item 10).
4. Install pin (Figure 4, Item 7) on sideshift cylinder assembly (Figure 4, Item 11).
5. Install retaining ring (Figure 4, Item 6), washer (Figure 4, Item 5), and nut (Figure 4, Item 4) on pin (Figure 4, Item 7).
6. Install two 90 degree fittings (Figure 4, Item 3) on sideshift cylinder assembly (Figure 4, Item 11).
7. Connect hose fittings (Figure 4, Items 1 and 2) to two 90 degree fittings (Figure 4, Item 3) and tighten.
8. Perform WP 0196 or WP 0197, *Installation*, step 12.

INSTALLATION/REPLACEMENT - CONTINUED

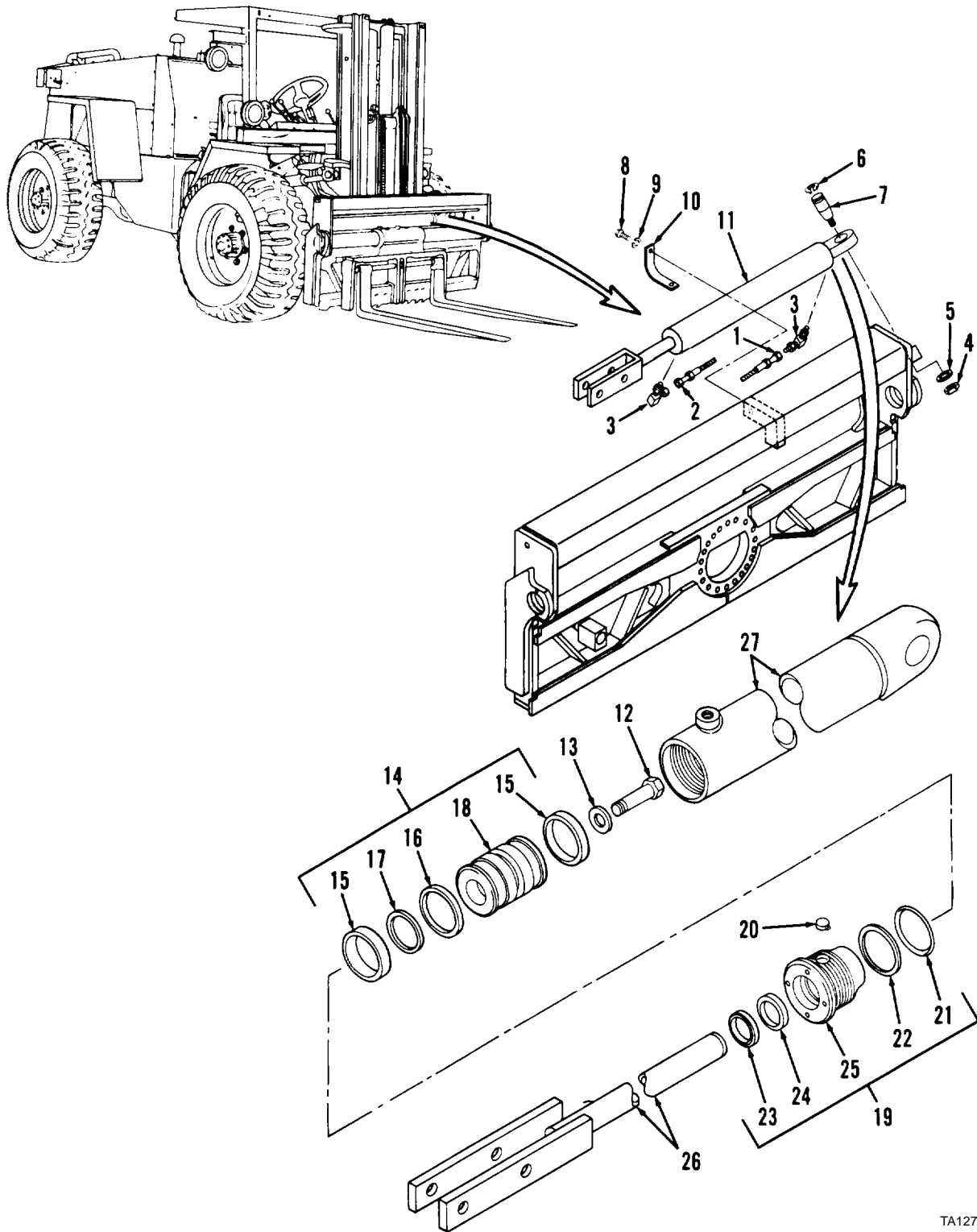

Figure 4. Sideshift Cylinder.

TA127181

END OF TASK  
END OF WORK PACKAGE



---

# DIRECT SUPPORT MAINTENANCE INSTRUCTIONS

## ROTATION CYLINDER MAINTENANCE

Removal, Disassembly, Cleaning, Inspection/Repair, Assembly, Testing, Installation

---

### INITIAL SETUP

#### Maintenance Level

Direct Support

#### Tools and Special Tools

Tool kit, general mechanic's (Item 15, WP 0309)  
Shop equipment, common no. 1 (Item 2, WP 0309)  
Chain hoist, 1/2-ton capacity  
Hydraulic pump (used for testing)  
Sleeve, 1-5/8 in. diameter

#### Materials/Parts

Cap set, protective (Item 9, WP 0310)  
Cleaning compound, solvent (Item 10, WP 0310)  
Lubricating oil, OE/HDO-10 (Item 20, WP 0310)  
Rag, wiping (Item 26, WP 0310)  
Emery cloth, medium grit  
Back-up ring

#### Materials/Parts - Continued

O-ring (2)  
Seal  
Sealing ring  
Wear ring  
Wiper

#### References

LO 10-3930-638-12  
WP 0196  
WP 0197

#### Equipment Condition

Vehicle parked on level surface  
Engine OFF  
Parking brake applied  
Mast vertical  
Forks resting on ground  
Control valve control levers operated several times  
to relieve hydraulic pressure

---

**REMOVAL**

Solvent cleaning compound MIL-PRF-680 Type III is an environmentally compliant and low toxic material. However, it may be irritating to the eyes and skin. Use protective gloves and goggles. Use in well-ventilated areas. Keep away from open flames and other sources of ignition. Failure to do so may result in injury or death to personnel.

**NOTE**

Caps all hoses, lines, and openings after disconnection.

1. Disconnect hose fittings (Figure 1, Items 1 and 2) from 90 degree elbow (Figure 1, Item 3) and 45 degree fitting (Figure 1, Item 4), respectively. Use solvent cleaning compound to clean hose fittings.
2. Remove 90 degree elbow (Figure 1, Item 3) from 90 degree fitting (Figure 1, Item 5).
3. Remove 45 degree fitting (Figure 1, Item 4) from 90 degree fitting (Figure 1, Item 5).
4. Remove two 90 degree fittings (Figure 1, Item 5) from cylinder (Figure 1, Item 27).
5. Remove two retaining rings (Figure 1, Item 6) and spacers (Figure 1, Item 7) from rod (Figure 1, Item 24).
6. Remove rotation cylinder assembly (Figure 1, Item 8) from vehicle.

**END OF TASK****DISASSEMBLY**

Solvent cleaning compound MIL-PRF-680 Type III is an environmentally compliant and low toxic material. However, it may be irritating to the eyes and skin. Use protective gloves and goggles. Use in well-ventilated areas. Keep away from open flames and other sources of ignition. Failure to do so may result in injury or death to personnel.

1. Use solvent cleaning compound to clean all exterior surfaces of rotation cylinder assembly (Figure 1, Item 8).
2. Remove two lubrication fittings (Figure 1, Item 9) from cylinder (Figure 1, Item 27).
3. Loosen gland assembly (Figure 1, Item 17).
4. Remove rod (Figure 1, Item 24), gland assembly (Figure 1, Item 17), and piston assembly (Figure 1, Item 12) as an assembly from rotation cylinder assembly (Figure 1, Item 8).
5. Remove capscrew (Figure 1, Item 10) and washer (Figure 1, Item 11) from rod (Figure 1, Item 24).
6. Remove piston assembly (Figure 1, Item 12) from rotation cylinder assembly (Figure 1, Item 8).
7. Remove gland assembly (Figure 1, Item 17) from rotation cylinder assembly (Figure 1, Item 8).
8. Remove wear ring (Figure 1, Item 13) from piston assembly (Figure 1, Item 12) and discard.
9. Remove sealing ring (Figure 1, Item 14) from piston assembly (Figure 1, Item 12) and discard.
10. Remove O-ring (Figure 1, Item 15) from piston assembly (Figure 1, Item 12) and discard.

DISASSEMBLY - CONTINUED

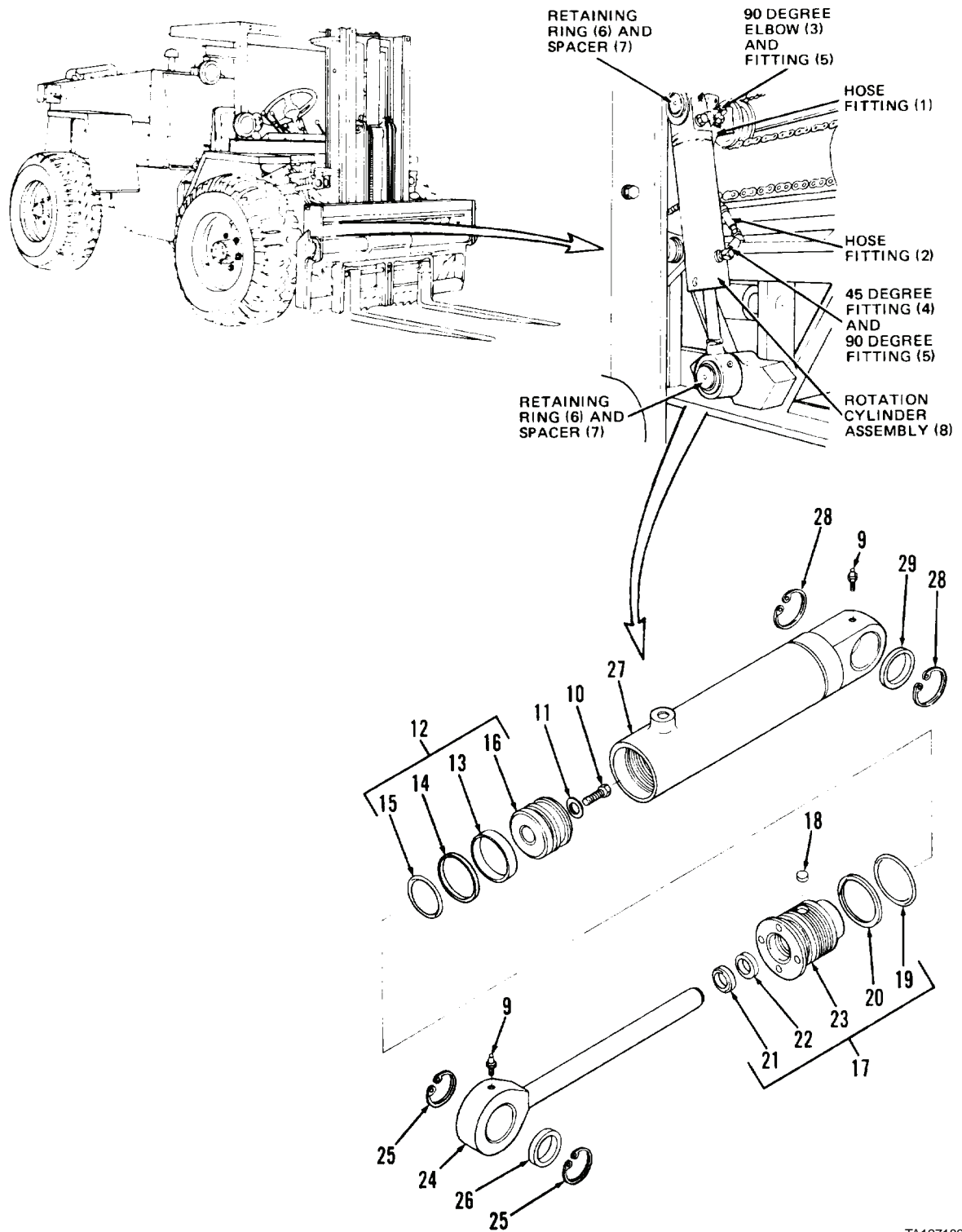

TA127182

Figure 1. Rotation Cylinder.

**DISASSEMBLY - CONTINUED**

11. Remove plug (Figure 2, Item 18) from gland (Figure 2, Item 23).
12. Remove O-ring (Figure 2, Item 19) from gland (Figure 2, Item 23) and discard.
13. Remove back-up ring (Figure 2, Item 20) from gland (Figure 2, Item 23) and discard.
14. Remove wiper (Figure 2, Item 21) from gland (Figure 2, Item 23) and discard.
15. Remove seal (Figure 2, Item 22) from gland (Figure 2, Item 23) and discard.

**NOTE**

Perform steps 16 through 19 only if inspection indicates replacement of bushings is necessary.

16. Remove two retaining rings (Figure 2, Item 25) from rod (Figure 2, Item 24).
17. Use 1-5/8-in. diameter sleeve to remove bushing (Figure 2, Item 26).
18. Remove two retaining rings (Figure 2, Item 28) from cylinder (Figure 2, Item 27).
19. Use 1-5/8-in. diameter sleeve to remove bushing (Figure 2, Item 29).

**END OF TASK****CLEANING****WARNING**

- Solvent cleaning compound MIL-PRF-680 Type III is an environmentally compliant and low toxic material. However, it may be irritating to the eyes and skin. Use protective gloves and goggles. Use in well-ventilated areas. Keep away from open flames and other sources of ignition. Failure to do so may result in injury or death to personnel.
- Particles blown by compressed air are hazardous. DO NOT exceed 15 PSI (103 kPa) nozzle pressure when drying parts with compressed air. DO NOT direct compressed air against human skin. Make sure air stream is directed away from user and other personnel in the area. To prevent injury, user must wear protective goggles or face shield. Failure to follow this warning may result in injury to personnel.

Use solvent cleaning compound to clean all parts. Dry with compressed air.

**END OF TASK****INSPECTION/REPAIR**

1. Inspect rod (Figure 2, Item 24). Replace if bent, deeply grooved, or scored. Remove nicks or scratches with medium-grit emery cloth polishing with a rotary motion.
2. Inspect cylinder (Figure 2, Item 27). Replace if deeply grooved, scored, or damaged. Remove nicks or scratches with medium-grit emery cloth polishing with a rotary motion.
3. Inspect bushings (Figure 2, Items 26 and 29). Replace if damaged, worn, cracked, or split.
4. Inspect all other parts. Replace if damaged, cracked, split, grooved, or scored.



INSPECTION/REPAIR - CONTINUED

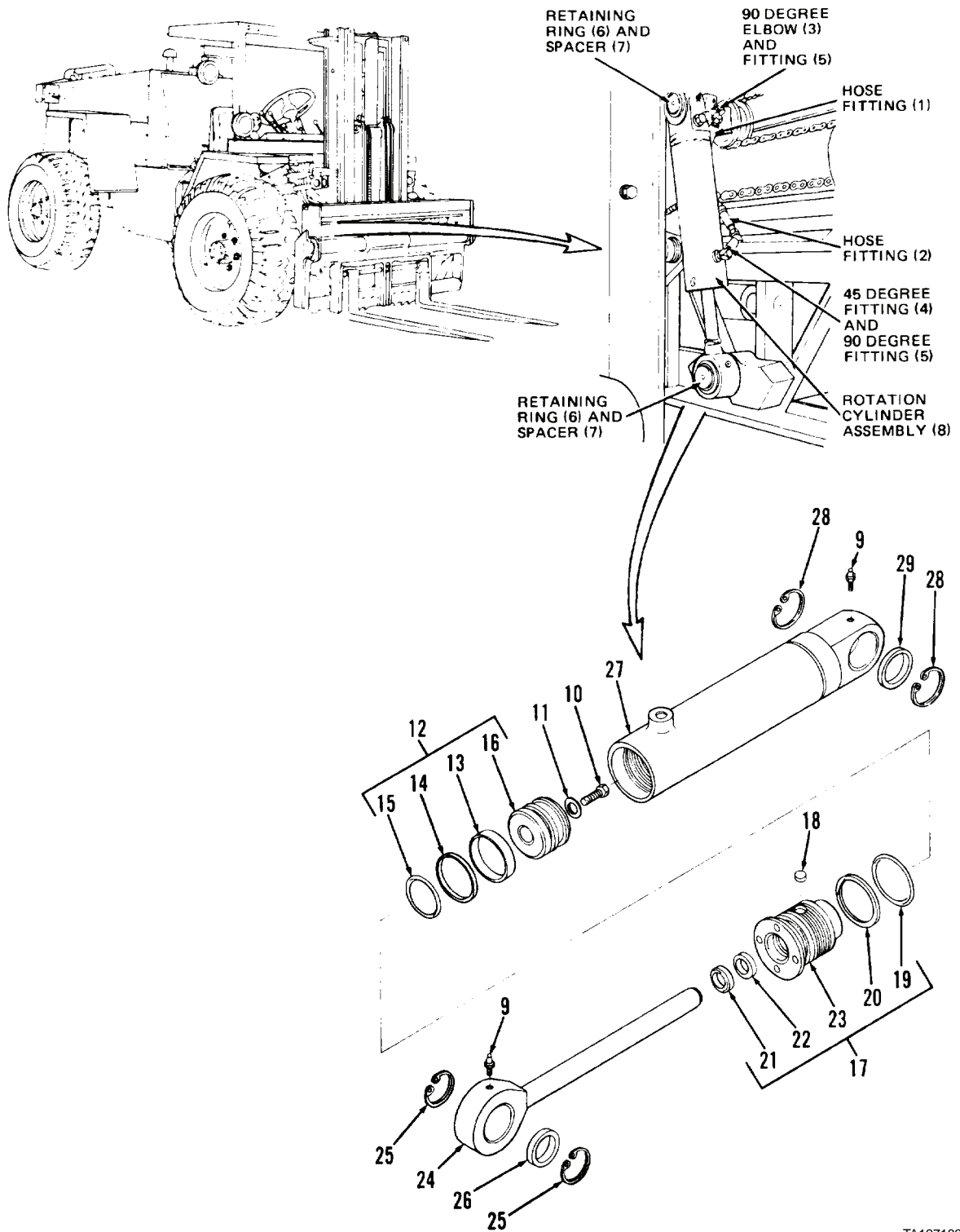

TA127182

Figure 2. Rotation Cylinder.

END OF TASK

**ASSEMBLY**

1. Use 1-5/8-in. diameter sleeve to install bushing (Figure 3, Item 29) on cylinder (Figure 3, Item 27) until centered.
2. Install two retaining rings (Figure 3, Item 28) on cylinder (Figure 3, Item 27).
3. Use 1-5/8-in. diameter sleeve to install bushing (Figure 3, Item 26) on rod (Figure 3, Item 24) until centered.
4. Install two new retaining rings (Figure 3, Item 25) on rod (Figure 3, Item 24).
5. Install new seal (Figure 3, Item 22) on gland (Figure 3, Item 23) with seal lip towards cylinder.
6. Install new wiper (Figure 3, Item 21) on gland (Figure 3, Item 23) with lip towards rod.
7. Install new back-up ring (Figure 3, Item 20) on gland (Figure 3, Item 23) with curved side towards O-ring (Figure 3, Item 19).
8. Install new O-ring (Figure 3, Item 19) on gland (Figure 3, Item 23).
9. Install plug (Figure 3, Item 18) on gland (Figure 3, Item 23).
10. Install new O-ring (Figure 3, Item 15) on piston (Figure 3, Item 16).
11. Install sealing ring (Figure 3, Item 14) on O-ring (Figure 3, Item 15).
12. Install wear ring (Figure 3, Item 13) on piston (Figure 3, Item 16).

**CAUTION**

Use extreme caution when performing step 13 not to damage parts.

13. Use clean lubricating oil to lubricate gland assembly (Figure 3, Item 17) and install on rod (Figure 3, Item 24).
14. Install piston assembly (Figure 3, Item 12) on rod (Figure 3, Item 24) with small diameter recess towards rod end.
15. Install washer (Figure 3, Item 11) and capscrew (Figure 3, Item 10) on rod (Figure 3, Item 24). Tighten capscrew to 90 to 100 lb-ft (122 to 136 Nm).
16. Use clean lubricating oil to lubricate sealing ring (Figure 3, Item 14).

**CAUTION**

Use extreme caution not to damage rings or seals when performing step 17.

17. Install rod (Figure 3, Item 24), gland assembly (Figure 3, Item 17), and piston assembly (Figure 3, Item 12) on cylinder (Figure 3, Item 27) as an assembly.
18. Position gland assembly (Figure 3, Item 17) and tighten to 100 to 150 lb-ft (136 to 203 Nm).
19. Install two lubrication fittings (Figure 3, Item 9) on rotation cylinder assembly (Figure 3, Item 8).

ASSEMBLY - CONTINUED

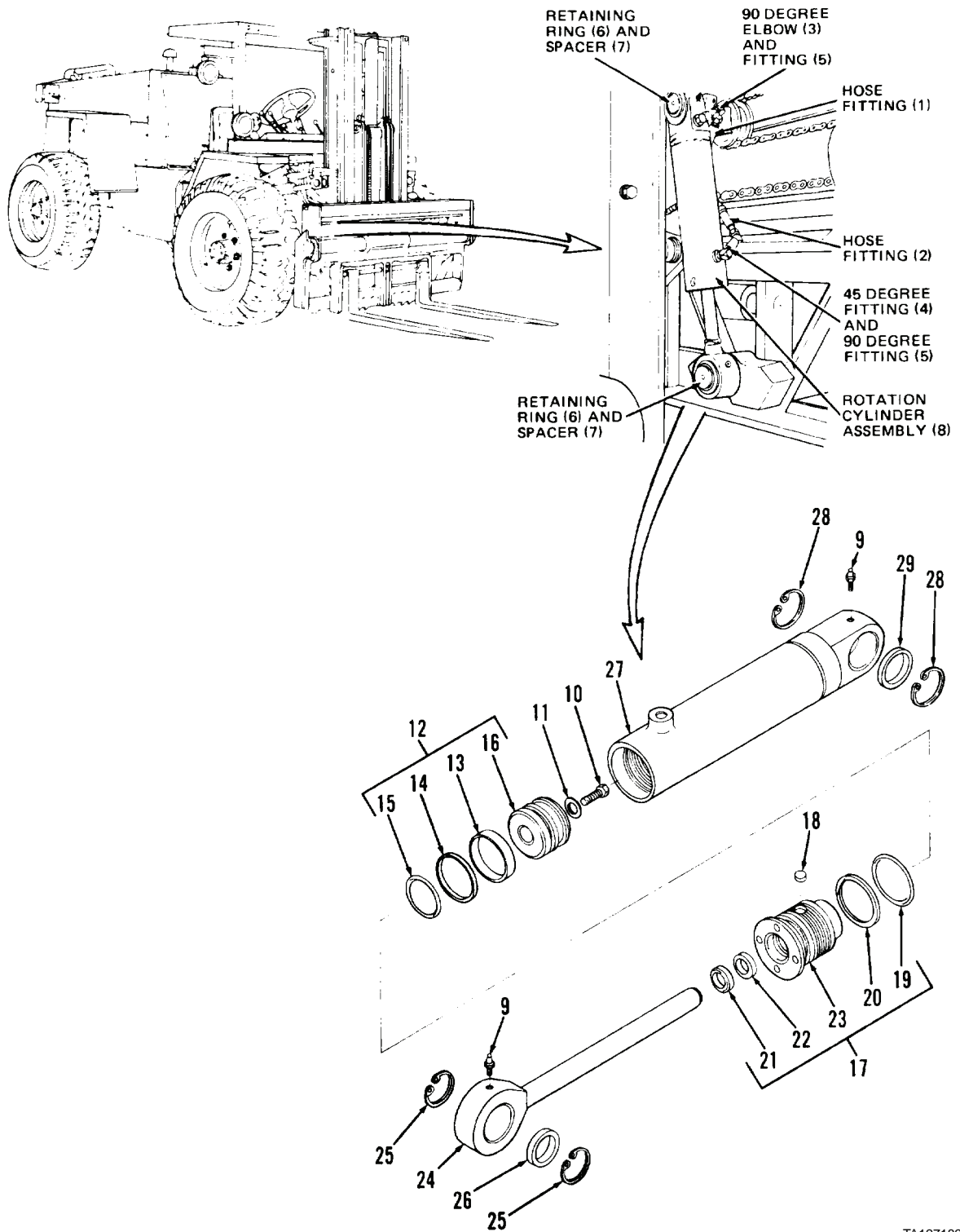

TA127182

Figure 3. Rotation Cylinder.

END OF TASK

---

**TESTING**

1. Rotation cylinder assembly cylinder port (port opposite rod end):
  - a. Connect hydraulic hose to port (hose must have a 7/16-20 fitting on end).
  - b. Connect other end of hose to test hydraulic pump.
2. Test hydraulic pump:
  - a. Start pump. Rod should extend smoothly from cylinder. Apply hydraulic oil under pressure (2,000 PSI [13,789 kPa]) to rotation assembly.
  - b. Continue operating pump until rod is completely extended from cylinder; hold until step 4 is completed.
3. Steering cylinder assembly:
  - a. Rod end port:
    - (1) Check for hydraulic oil leakage.
    - (2) Slight leakage of oil is permissible; if leakage is too great, disassemble cylinder and check piston assembly (Figure 4, Item 12) for damage.
  - b. Rod end packing:
    - (1) Check for hydraulic oil leakage.
    - (2) If leakage is observed, disassemble cylinder and check piston assembly (Figure 4, Item 17) for damage.
4. Test hydraulic pump:

Shut pump down.
5. Steering cylinder assembly cylinder port (port opposite rod end):
  - a. Disconnect hydraulic hose and drain oil from cylinder.
  - b. Push rod into cylinder.
  - c. Cap both cylinder ports.

**END OF TASK****INSTALLATION**

1. Position rotation cylinder assembly (Figure 4, Item 8) on carriage mounting pins.
2. Install two spacers (Figure 4, Item 7) and retaining rings (Figure 4, Item 6) on rod (Figure 4, Item 24).
3. Install two 90 degree fittings (Figure 4, Item 5) on cylinder (Figure 4, Item 27).
4. Install 45 degree fitting (Figure 4, Item 4) on 90 degree fitting (Figure 4, Item 5).
5. Install 90 degree elbow (Figure 4, Item 3) on 90 degree fitting (Figure 4, Item 5).
6. Connect hose fittings (Figure 4, Items 1 and 2) to 90 degree elbow (Figure 4, Item 3) and 45 degree fitting (Figure 4, Item 4), respectively.
7. Perform WP 0196 or WP 0197, *Installation*, step 12.
8. Lubricate two lubrication fittings (Figure 4, Item 9) on cylinder (Figure 4, Item 27) (LO 10-3930-638-12).

INSTALLATION - CONTINUED

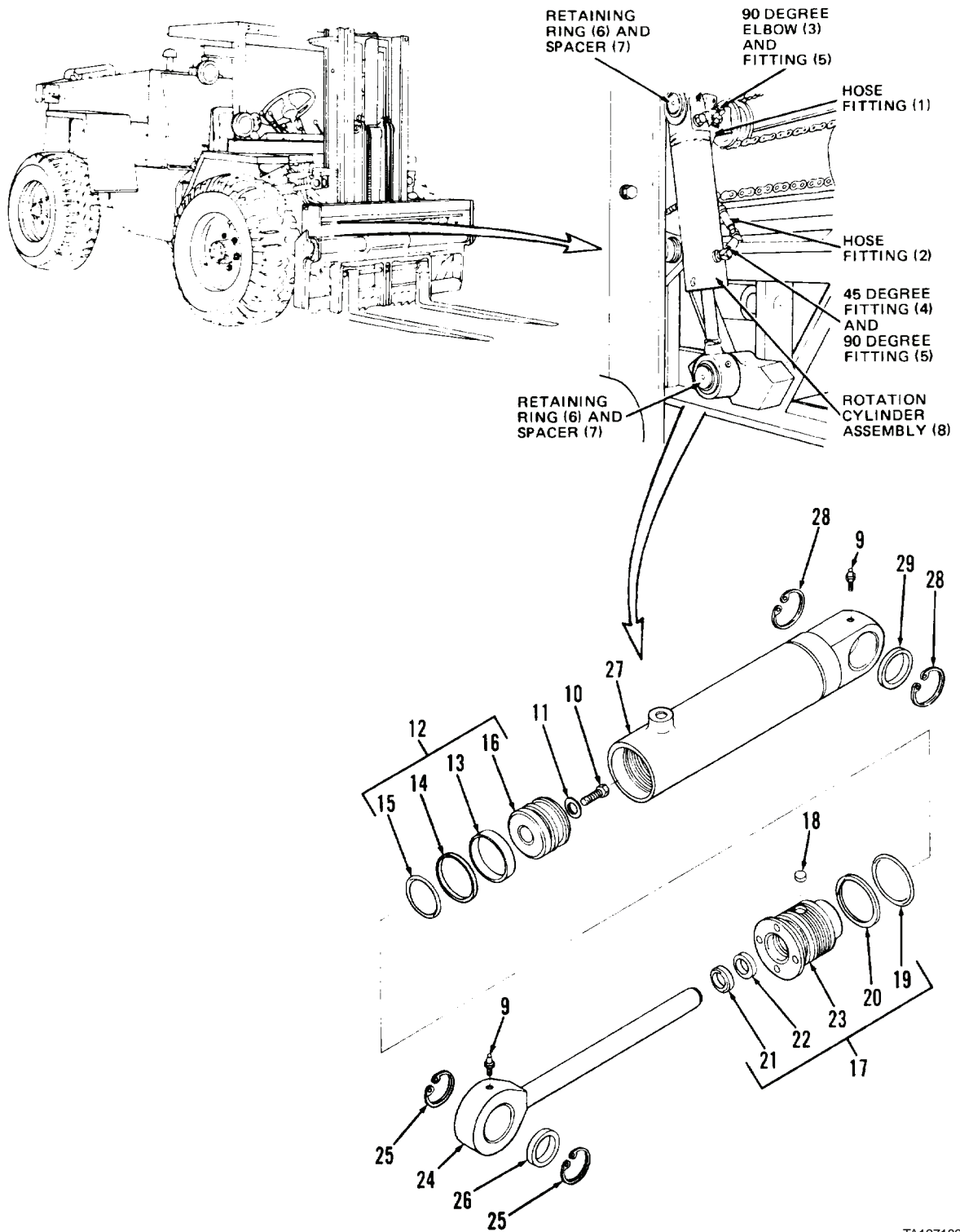

TA127182

Figure 4. Rotation Cylinder.

END OF TASK  
END OF WORK PACKAGE



---

## DIRECT SUPPORT MAINTENANCE INSTRUCTIONS

### LIFT CYLINDER MAINTENANCE

Removal, Disassembly, Cleaning, Inspection/Repair, Assembly, Installation

---

#### INITIAL SETUP

##### Maintenance Level

Direct Support

##### Tools and Special Tools

Tool kit, general mechanic's (Item 15, WP 0309)  
 Shop equipment, common no. 1 (Item 2, WP 0309)  
 Spanner wrench (Item 9, WP 0309)  
 Spanner wrench (Item 10, WP 0309)  
 Brass jaw vise and support stand  
 Chain hoists (2), 1/2-ton capacity each  
 Container, 6-gal. capacity  
 Insertion sleeve, external taper (P/N CAS1704-1)  
 Insertion sleeve, internal taper (P/N CAS1704-2)  
 Nylon straps (for use with chain hoists)  
 Wood blocks (2), 6 x 6 x 12 in.

##### Materials/Parts

Cap set, protective (Item 9, WP 0310)  
 Cleaning compound, solvent (Item 10, WP 0310)  
 Lubricating oil, OE/HDO-10 (Item 20, WP 0310)  
 Rag, wiping (Item 26, WP 0310)  
 Back-up ring (5)  
 Bearing (2)  
 Emery cloth, medium grit

##### Materials/Parts - Continued

Lockwasher (4)  
 O-ring (4)  
 Safety wire  
 Seal (3)  
 Seal repair kit  
 Wear ring (4)  
 Wiper (3)

##### Personnel Required

Two

##### References

WP 0193  
 WP 0195

##### Equipment Condition

Vehicle parked on level surface  
 Engine OFF  
 Parking brake applied  
 Mast vertical  
 Carriage assembly raised 1 ft from ground and  
 securely blocked  
 Control valve control levers operated several times  
 to relieve hydraulic pressure

---

## REMOVAL



## WARNING

Hydraulic system is under pressure. Before disconnecting any hoses, lines, or fittings, operate all hydraulic lift control levers to relieve hydraulic system pressure. Failure to do so could cause injury or death to personnel.

## NOTE

Cap and plug all hoses, lines, and openings after disconnection.

1. Remove two hose pulleys (Figure 1, Item 1) (WP 0193, *Removal*, steps 8 through 12).
2. Position four hose assemblies (Figure 1, Item 2) aside.
3. Position two lift chains (Figure 1, Item 3) aside.
4. Remove two chain pulleys (Figure 1, Item 4) and pulley bars (Figure 1, Item 5) (WP 0193, *Removal*, steps 13 through 16).

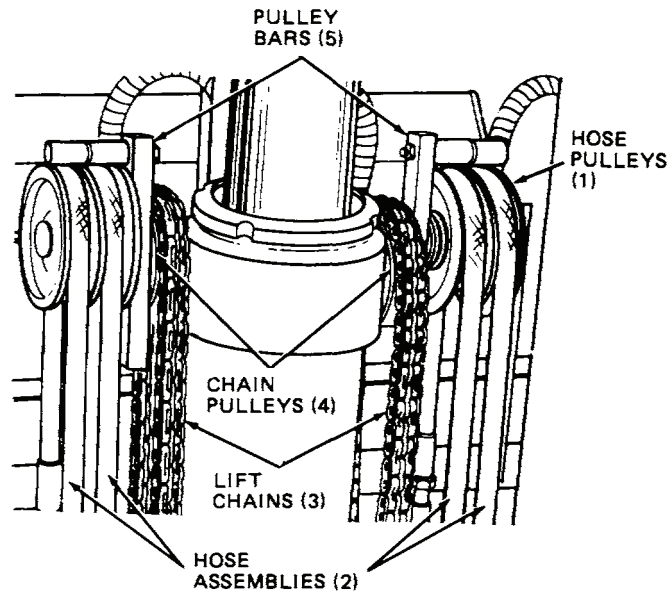

SERIAL NUMBER 9150573 AND ABOVE

TA301534

**Figure 1. Hose Assemblies and Pulleys.**

5. Remove and discard safety wire (Figure 2, Item 6) from top of mast assembly.
6. Remove two capscrews (Figure 2, Item 7), washers (Figure 2, Item 8), spacers (Figure 2, Item 9), and washers (Figure 2, Item 10).
7. Attach chain hoist to top of inner mast.
8. Raise inner mast 20 in. (508 mm).
9. Attach chain hoist to lift cylinder assembly under chain trunnion roller spacers using nylon straps.
10. For serial numbers 9150573 and above, remove four capscrews (Figure 2, Item 11A), lockwashers (Figure 2, Item 11B), and washers (Figure 2, Item 11C) from bottom of mast assembly. Discard lockwashers.



**REMOVAL - CONTINUED**

11. For serial numbers 9150573 and above, remove guard (Figure 2, Item 11D) from bottom of mast.
12. Place 6-gal. (23-L) container under hose fitting (Figure 2, Item 12).
13. Clean and disconnect hose fitting (Figure 2, Item 12) from elbow (Figure 2, Item 13).
14. Remove elbow (Figure 2, Item 13) from restrictor (Figure 2, Item 14).
15. Remove restrictor (Figure 2, Item 14) from bottom of mast.



**WARNING**

Wear protective goggles when performing step 16. Failure to do so could cause blindness or injury due to retaining ring flying off its groove and striking your eye.

16. Remove retaining ring (Figure 2, Item 15) from lift cylinder assembly (Figure 2, Item 11).

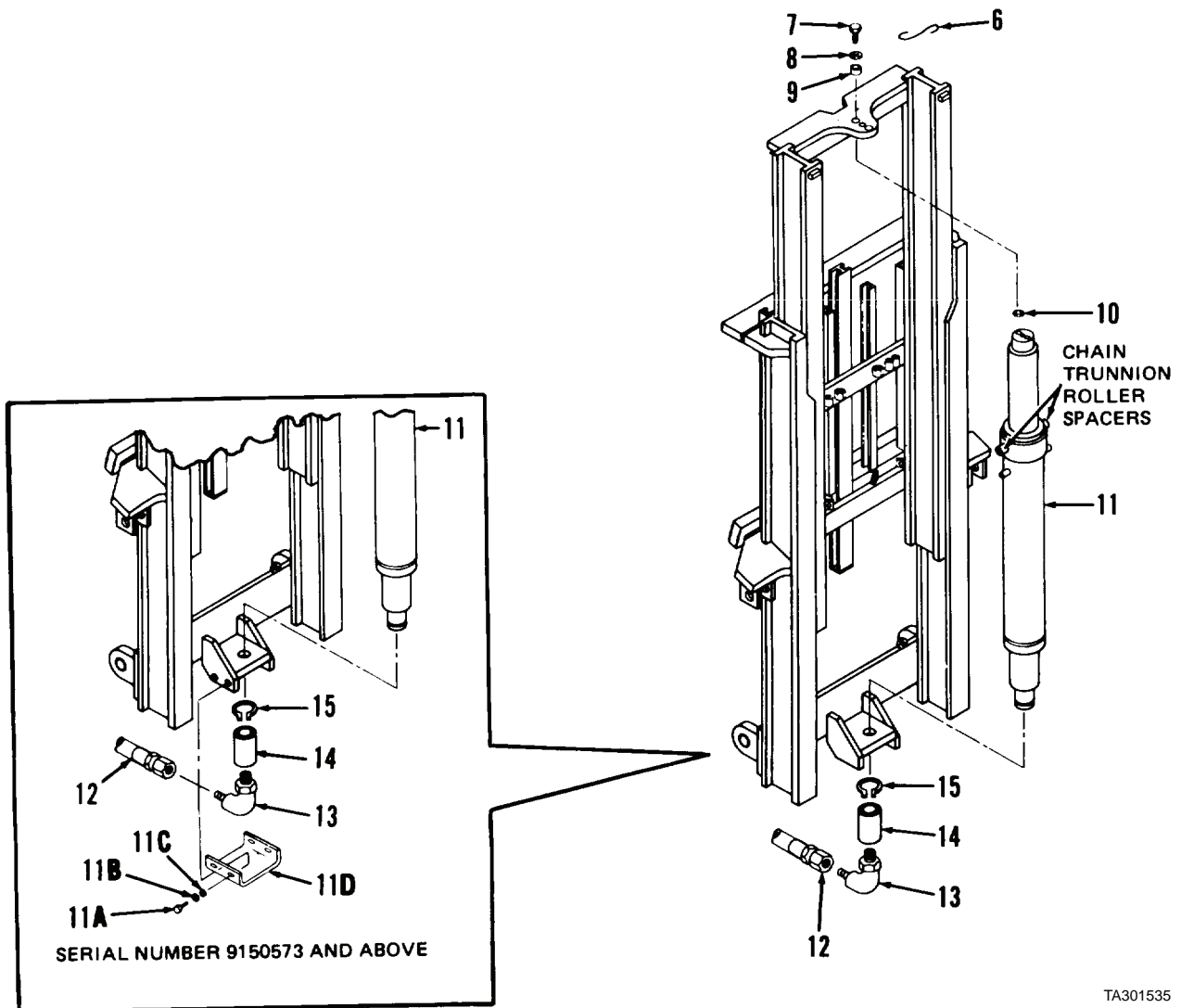

Figure 2. Mast.

TA301535

REMOVAL - CONTINUED



WARNING



- Keep clear of carriage assembly and lift cylinder assembly when performing following step. Do not place any part of your body between carriage and mast assemblies or beneath lift cylinder. Failure to follow this warning may result in injury or death to personnel due to jack stand falling.
- Be sure lift cylinder assembly is securely fastened to chain hoist. Keep clear of carriage assembly and lift cylinder assembly. Failure to do so may result in lift cylinder assembly falling, striking personnel and causing injury or death.

17. Slowly raise lift cylinder assembly (Figure 3, Item 11). Ensure inner tube (Figure 4, Item 33) of lift cylinder assembly is not extending out from bottom of lift cylinder assembly. If inner tube of lift cylinder assembly is extending out from bottom of lift cylinder assembly, use tool to compress it.

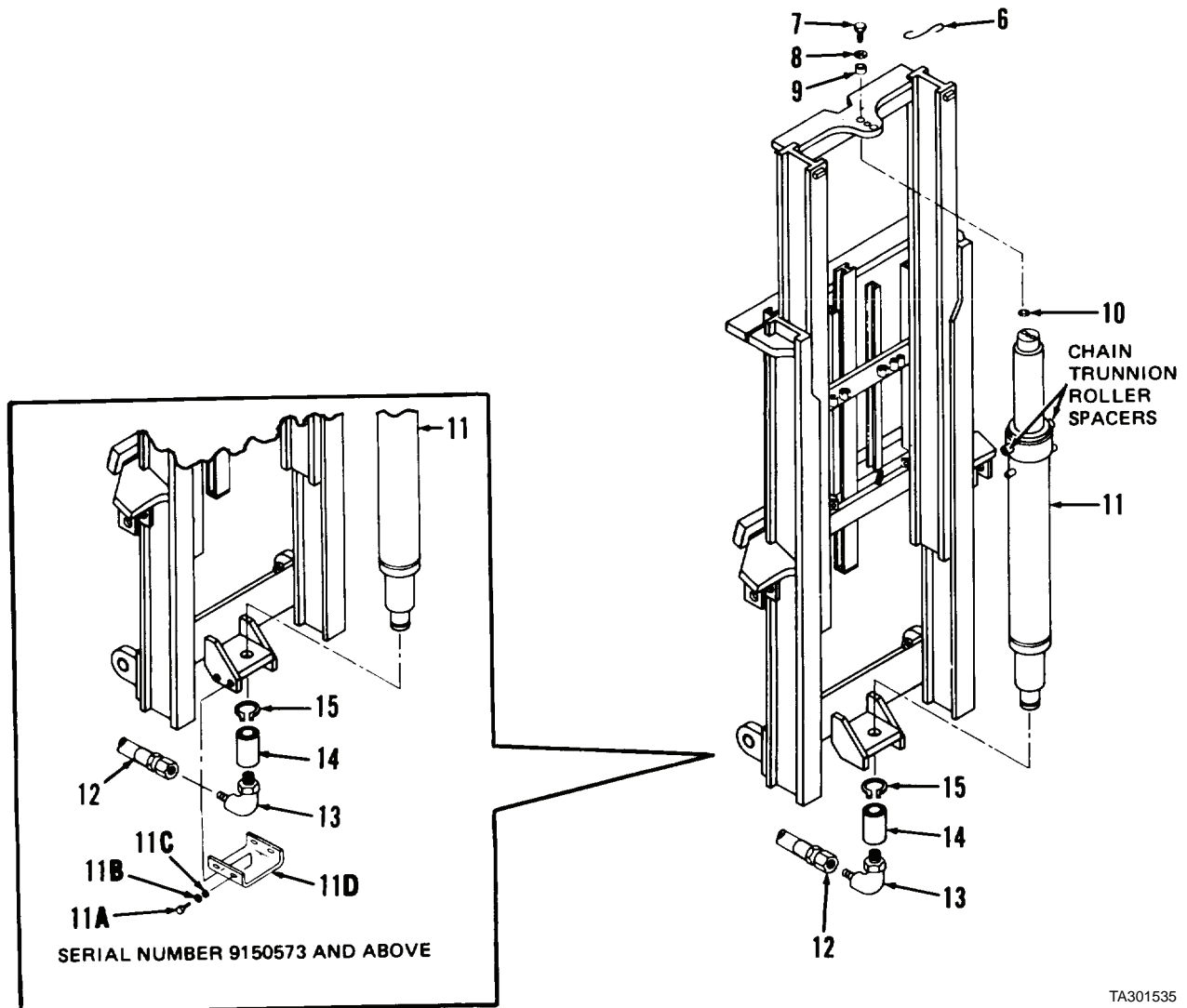

Figure 3. Mast.

TA301535

END OF TASK

DISASSEMBLY

NOTE

Position outer tube in brass-jawed vise (or use wood blocks between vise jaws and outer tube): support other end of lift cylinder assembly.

1. Position container beneath end cap assembly (Figure 4, Item 16), then remove from outer tube (Figure 4, Item 35).
2. Remove ring assembly (Figure 4, Item 22) from lift cylinder assembly (Figure 3, Item 11).
3. Use spanner wrench (Item 19, WP 0310) to remove gland assembly (Figure 4, Item 25) from lift cylinder assembly (Figure 4, Item 11).
4. Remove inner tube (Figure 4, Item 33) from bottom of cylinder (Figure 4, Item 54).
5. Remove gland assembly (Figure 4, Item 46) from cylinder (Figure 4, Item 54).
6. Remove outer tube (Figure 4, Item 35), retaining rings (Figure 4, Items 36 and 37), and piston assembly (Figure 4, Item 38) as an assembly from top of cylinder (Figure 4, Item 54) and place on wooden blocks.

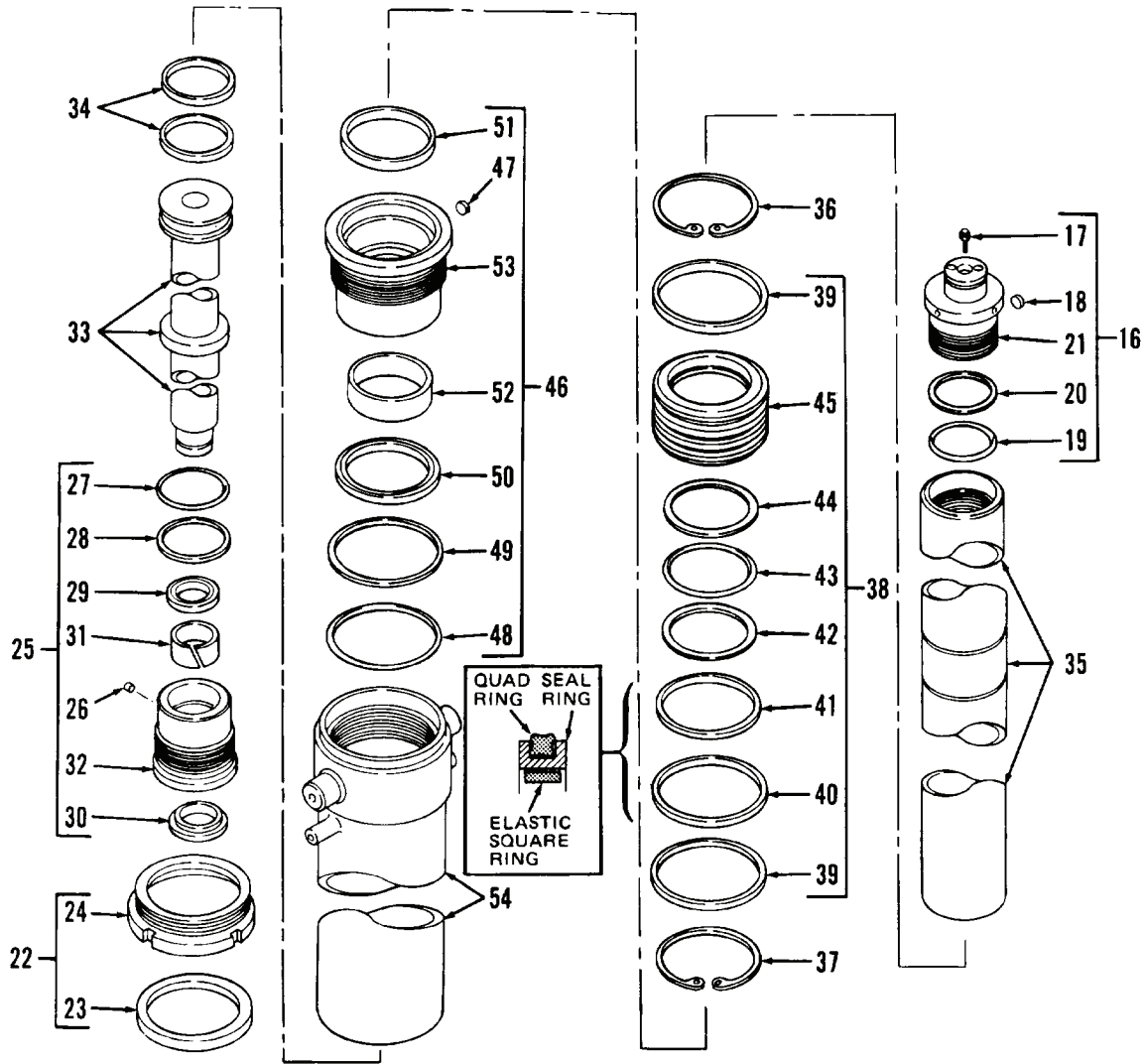

TA301537

Figure 4. Lift Cylinder.

**DISASSEMBLY - CONTINUED**

7. Remove bleed screw (Figure 5, Item 17) from end cap assembly (Figure 5, Item 16).
8. Remove plug (Figure 5, Item 18) from end cap assembly (Figure 5, Item 16).
9. Remove O-ring (Figure 5, Item 19) from end cap assembly (Figure 5, Item 16) and discard.
10. Remove back-up ring (Figure 5, Item 20) from end cap assembly (Figure 5, Item 16) and discard.
11. Remove wiper (Figure 5, Item 23) from ring assembly (Figure 5, Item 22) and discard.
12. Remove plug (Figure 5, Item 26) from gland assembly (Figure 5, Item 25) and discard.
13. Remove O-ring (Figure 5, Item 27) from gland assembly (Figure 5, Item 25) and discard.
14. Remove back-up ring (Figure 5, Item 28) from gland assembly (Figure 5, Item 25) and discard.
15. Remove seal (Figure 5, Item 29) from gland assembly (Figure 5, Item 25) and discard.
16. Remove wiper (Figure 5, Item 30) from gland assembly (Figure 5, Item 25) and discard.
17. Remove bearing (Figure 5, Item 31) from gland assembly (Figure 5, Item 25) and discard.
18. Remove two wear rings (Figure 5, Item 34) from inner tube (Figure 5, Item 33) and discard.
19. Remove retaining rings (Figure 5, Items 36 and 37) from outer tube (Figure 5, Item 35).
20. Remove piston assembly (Figure 5, Item 38) from lift cylinder assembly (Figure 5, Item 11).
21. Remove two wear rings (Figure 5, Item 39) from piston assembly (Figure 5, Item 38) and discard.
22. Remove seal (Figure 5, Item 40) from piston assembly (Figure 5, Item 38) and discard.
23. Remove loader ring (Figure 5, Item 41) from piston assembly (Figure 5, Item 38) and discard.
24. Remove back-up ring (Figure 5, Item 42) from piston assembly (Figure 5, Item 38) and discard.
25. Remove O-ring (Figure 5, Item 43) from piston assembly (Figure 5, Item 38) and discard.
26. Remove back-up ring (Figure 5, Item 44) from piston assembly (Figure 5, Item 38) and discard.
27. Remove plug (Figure 5, Item 47) from gland assembly (Figure 5, Item 46) and discard.
28. Remove O-ring (Figure 5, Item 48) from gland assembly (Figure 5, Item 46) and discard.
29. Remove back-up ring (Figure 5, Item 49) from gland assembly (Figure 5, Item 46) and discard.
30. Remove seal (Figure 5, Item 50) from gland assembly (Figure 5, Item 46) and discard.
31. Remove wiper (Figure 5, Item 51) from gland assembly (Figure 5, Item 46) and discard.
32. Remove bearing (Figure 5, Item 52) from gland assembly (Figure 5, Item 46) and discard.

**END OF TASK****CLEANING****WARNING**

- Solvent cleaning compound MIL-PRF-680 Type III is an environmentally compliant and low toxic material. However, it may be irritating to the eyes and skin. Use protective gloves and goggles. Use in well-ventilated areas. Keep away from open flames and other sources of ignition. Failure to do so may result in injury or death to personnel.
- Particles blown by compressed air are hazardous. DO NOT exceed 15 PSI (103 kPa) nozzle pressure when drying parts with compressed air. DO NOT direct compressed air against human skin. Make sure air stream is directed away from user and other personnel in the area. To prevent injury, user must wear protective goggles or face shield. Failure to follow this warning may result in injury to personnel.

Use solvent cleaning compound to clean all parts. Dry with compressed air.

**END OF TASK**

**INSPECTION/REPAIR**

1. Inspect tubes (Figure 5, Items 33 and 35). Replace if bent, deformed, deeply grooved, or scored. Remove nicks or scratches with medium-grit emery cloth polishing with a rotary motion.
2. Inspect cylinder (Figure 5, Item 54). Replace if cracked, deeply grooved, or scored. Remove nicks or scratches with medium-grit emery cloth polishing with a rotary motion.
3. Inspect all other parts. Replace if damaged, cracked, split, grooved, or scored.

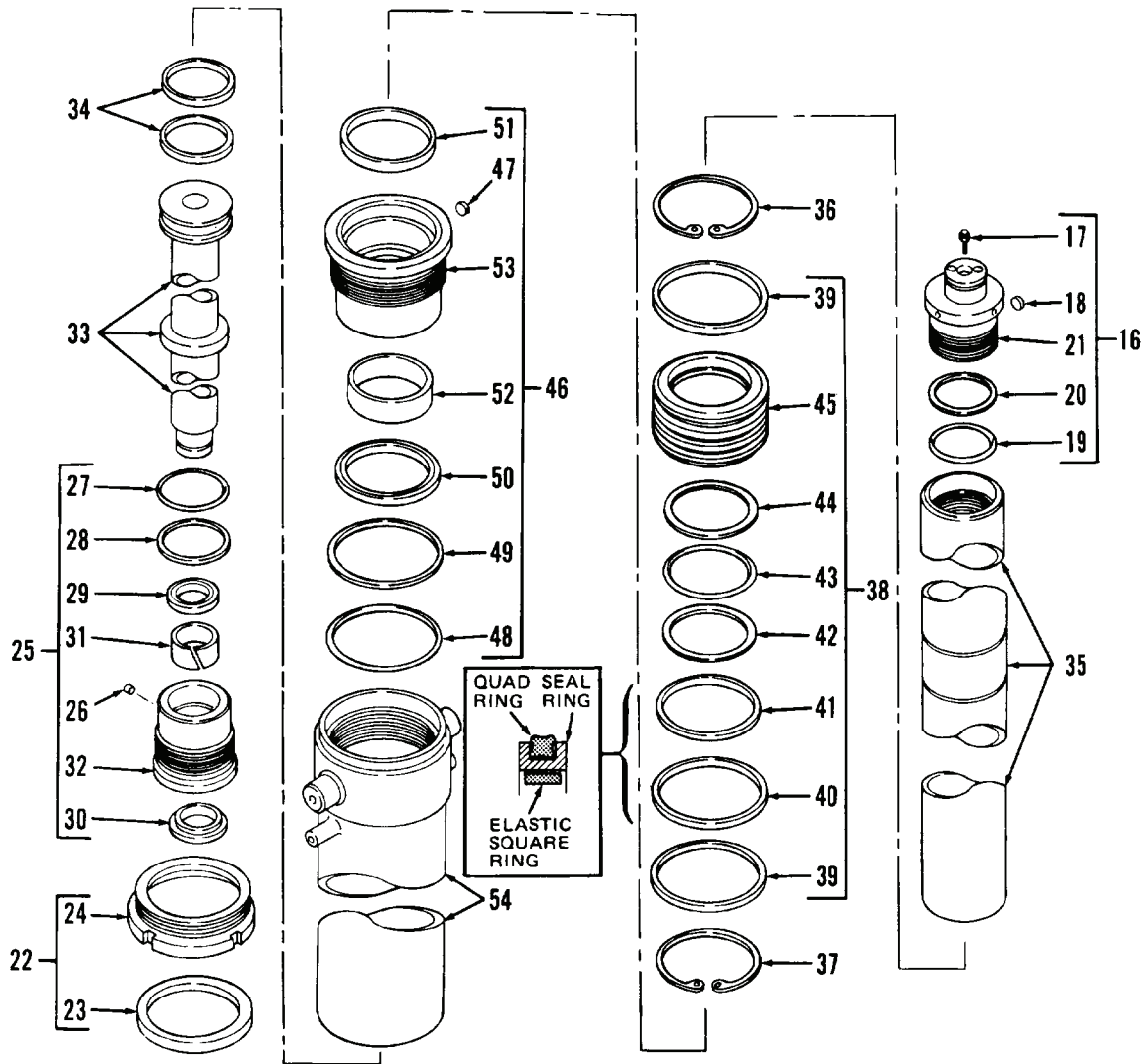

TA301537

**Figure 5. Lift Cylinder.**

**END OF TASK**

**ASSEMBLY**

1. Install new bearing (Figure 6, Item 52) on gland (Figure 6, Item 53).
2. Install new wiper (Figure 6, Item 51) on bearing (Figure 6, Item 52) with lip outwards.
3. Install new seal (Figure 6, Item 50) on bearing (Figure 6, Item 52) with lip outwards.
4. Install new back-up ring (Figure 6, Item 49) on bearing (Figure 6, Item 52) with curved side towards O-ring (Figure 6, Item 48).
5. Install new O-ring (Figure 6, Item 48) on bearing (Figure 6, Item 52).
6. Install plug (Figure 6, Item 47) on bearing (Figure 6, Item 52).
7. Install new back-up ring (Figure 6, Item 44) on piston (Figure 6, Item 45).
8. Install new O-ring (Figure 6, Item 43) on piston (Figure 6, Item 45).
9. Install new back-up ring (Figure 6, Item 42) on piston (Figure 6, Item 45).

**NOTE**

Loader ring (Figure 6, Item 41) is not used when seal repair kit is installed. Loader ring is replaced by three-piece seal (Figure 6, Item 40) supplied with seal repair kit.

10. Install two new wear rings (Figure 6, Item 39) on piston (Figure 6, Item 45).
11. Install new bearing (Figure 6, Item 31) on gland (Figure 6, Item 32).
12. Install new wiper (Figure 6, Item 30) on gland (Figure 6, Item 32) with lip outwards.
13. Install new seal (Figure 6, Item 29) on gland (Figure 6, Item 32) with lip outwards.
14. Install new back-up ring (Figure 6, Item 28) on gland (Figure 6, Item 32) with curved side towards O-ring (Figure 6, Item 27).
15. Install new O-ring (Figure 6, Item 27) on gland (Figure 6, Item 32).
16. Install plug (Figure 6, Item 26) on gland (Figure 6, Item 32).
17. Install two new wear rings (Figure 6, Item 34) from inner tube (Figure 6, Item 33) side-by-side in groove.
18. Install new wiper (Figure 6, Item 23) on ring (Figure 6, Item 24) with lip outwards.
19. Install new back-up ring (Figure 6, Item 20) on end cap (Figure 6, Item 21) with curved side towards O-ring (Figure 6, Item 19).
20. Install new O-ring (Figure 6, Item 19) on end cap (Figure 6, Item 21).
21. Install plug (Figure 6, Item 18) on end cap (Figure 6, Item 21).
22. Install bleed screw (Figure 6, Item 17) on end cap (Figure 6, Item 21).
23. Install retaining ring (Figure 6, Item 37) from outer tube (Figure 6, Item 35). Make sure ring is properly seated in groove.

**CAUTION**

Be careful not to damage back-up rings (Figure 6, Items 42 and 44) or O-ring (Figure 6, Item 43) when performing step 24. Exercise extreme caution when using tools CAS1704-1 and CAS1704-2; they are fragile.

24. Use clean lubricating oil to lubricate piston assembly (Figure 6, Item 38) and install on tube (Figure 6, Item 35).
25. Install retaining ring (Figure 6, Item 36) on tube (Figure 6, Item 35). Make sure ring is properly seated in groove.

ASSEMBLY - CONTINUED

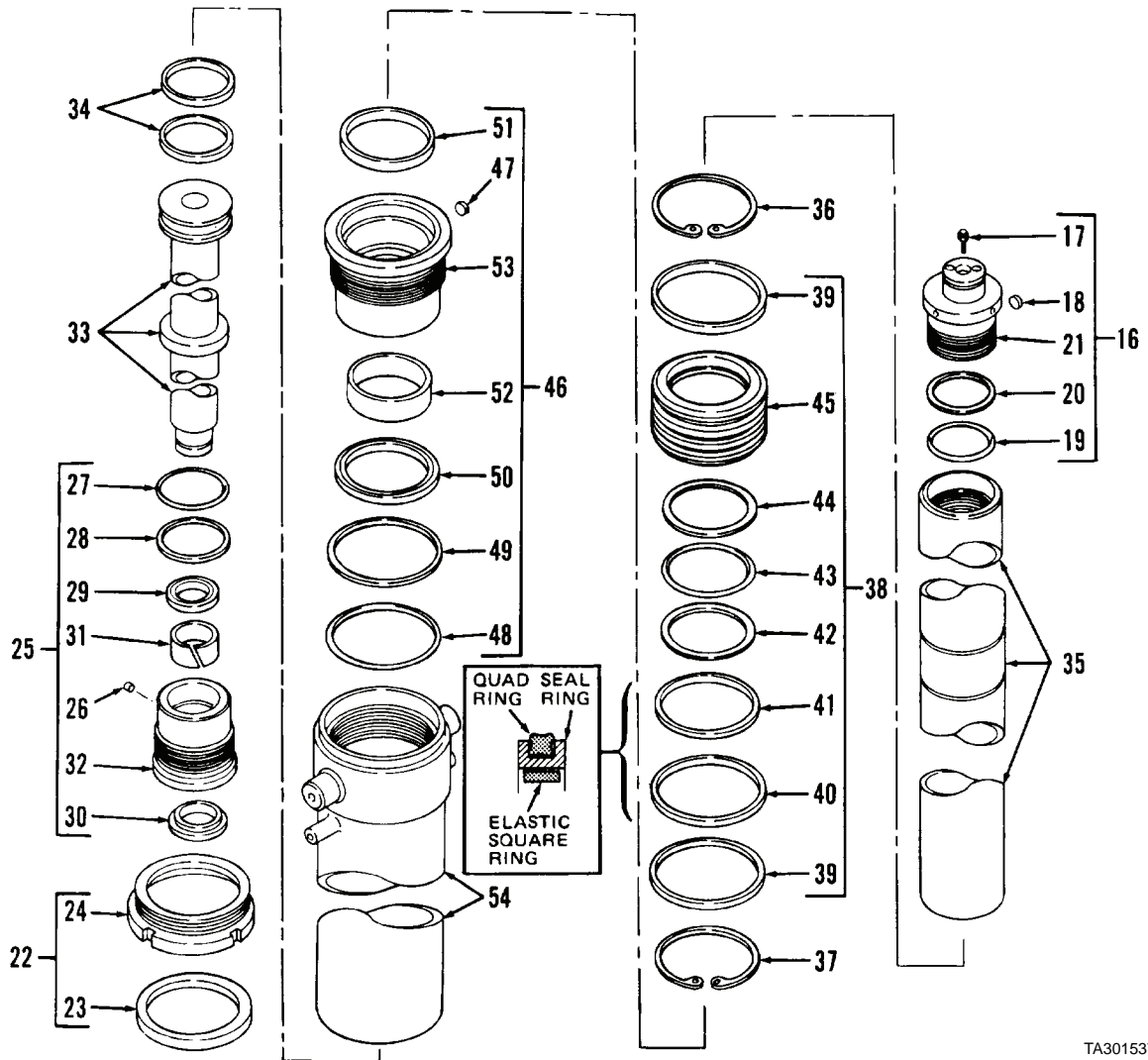

Figure 6. Lift Cylinder.

TA301537

**ASSEMBLY - CONTINUED****NOTE**

It may be necessary to remove bottom wear ring when performing following step 26.

26. Apply hydraulic oil to all surfaces and install tool CAS1704-1 on outer tube as shown (Figure 7). Large end of tool is positioned over piston assembly. Rotate tool until small notch inside of tool covers ears of retaining ring. Tool should then be flush with center groove of piston assembly.
27. Separate elastic square ring from seal ring if not already separated.
28. Liberally apply clean engine oil to elastic square ring, slide over tool CAS1704-1, and install in center groove of piston assembly (Figure 7). Use fingertips and slow, even pressure to pull ring over tool until ring falls into position in center groove.
29. Liberally apply clean engine oil to seal ring, slide over tool CAS1704-1, and install in center groove of piston assembly. Use fingertips and slow, even pressure to pull ring over tool until ring falls into position in center groove.
30. Remove tool CAS1704-1 from outer tube (Figure 7).

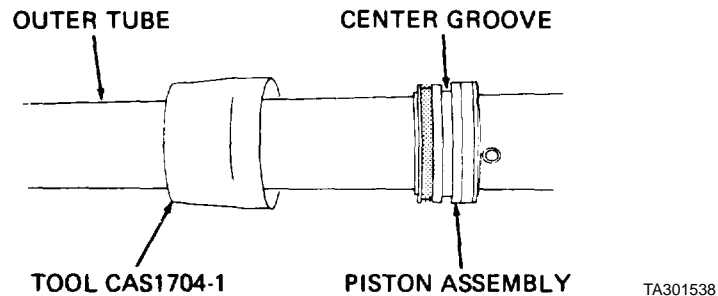

**Figure 7. Tool and Piston Assembly.**

31. Install new bottom wear ring (Figure 8, Item 39) on lift cylinder assembly (Figure 8, Item 11).
32. Use clean engine oil to lubricate inner tube (Figure 8, Item 33) and install inner tube on outer tube (Figure 8, Item 35).
33. Use clean lubricating oil to lubricate gland assembly (Figure 8, Item 25), slide gland assembly on inner tube (Figure 8, Item 33), connect to outer tube (Figure 8, Item 35) and tighten after metal-to-metal contact.
34. Use clean engine oil to lubricate end cap assembly (Figure 8, Item 16) and install end cap assembly on cylinder (Figure 8, Item 54). Tighten after metal-to-metal contact.



ASSEMBLY - CONTINUED

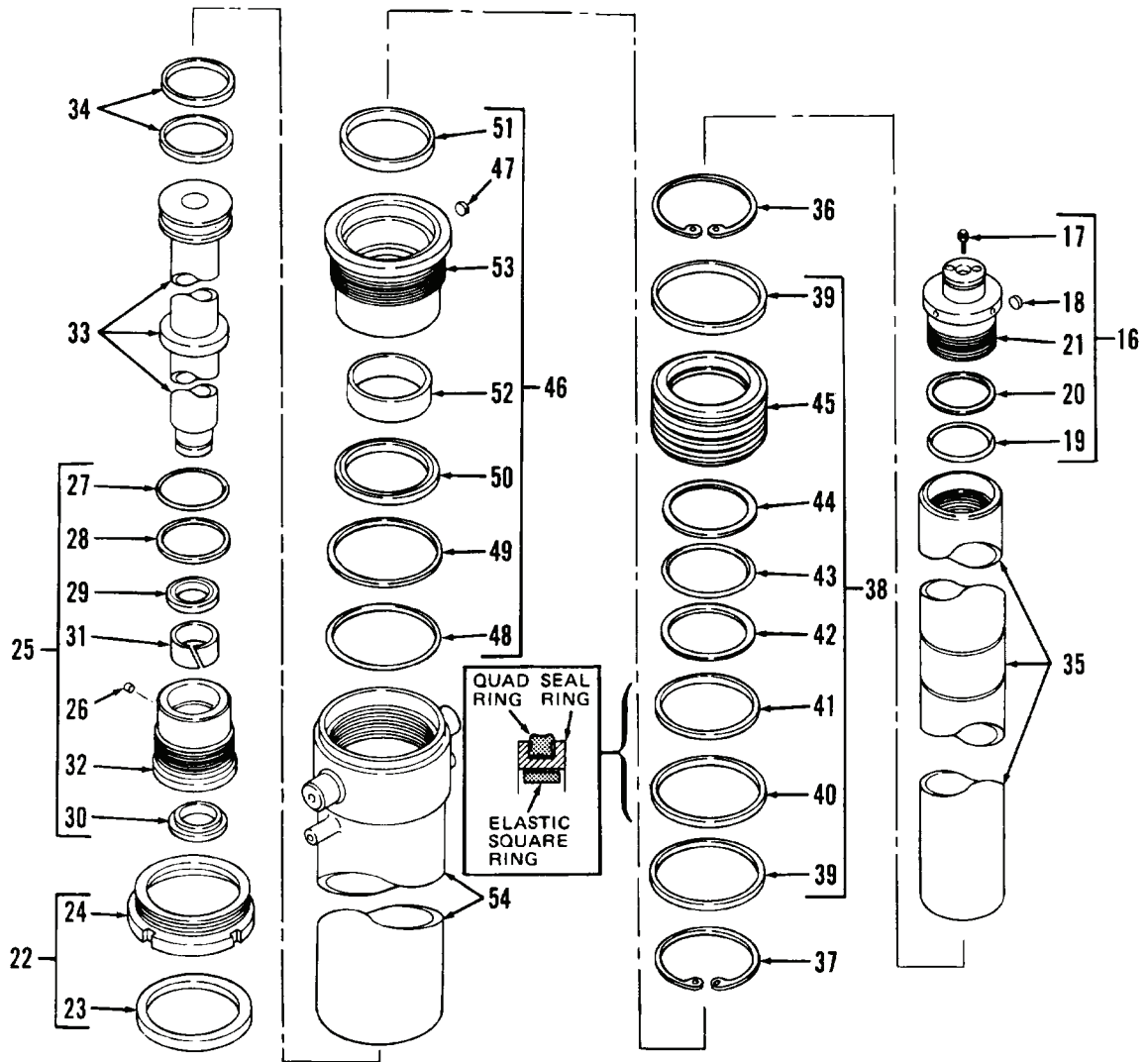

Figure 8. Lift Cylinder.

TA301537

**ASSEMBLY - CONTINUED**

35. Use clean engine oil to lubricate tool CAS1704-2 and install tool on cylinder (Figure 9) and hand-tighten. Use of spanner wrench may be necessary.

**NOTE**

If tool CAS1704-2 cannot be completely installed in cylinder, cylinder may be distorted due to too much pressure exerted by vise. Loosen vise grip on cylinder, then repeat step 35.

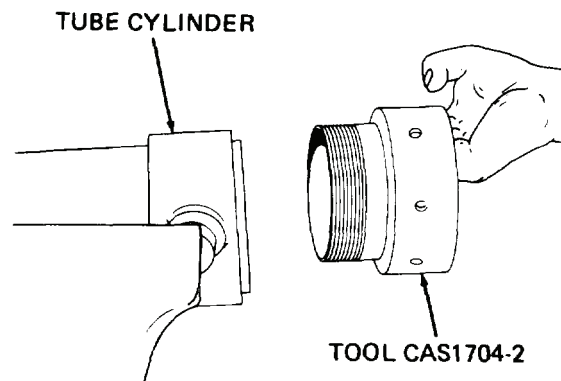

TA301539

**Figure 9. Tool and Cylinder.**

36. Remove inner tube (Figure 11, Item 33) from outer tube (Figure 11, Item 35) until it bottoms in outer tube.

**CAUTION**

When performing the following steps, be careful not to damage parts.

37. With assistance, slowly install inner tube (Figure 11, Item 33) and outer tube (Figure 11, Item 35) through tool CAS1704-2 and top of cylinder (Figure 11, Item 54) until piston assembly is inside tool CAS1704-2 (Figure 10).

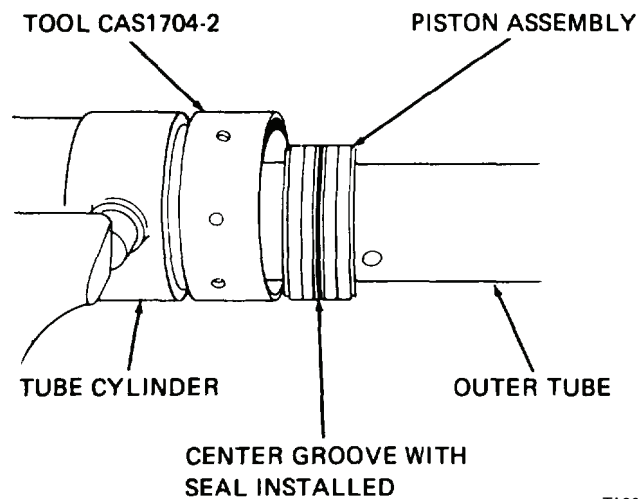

TA301540

**Figure 10. Installing Piston.**

**ASSEMBLY - CONTINUED**

- 38. Hold outer tube (Figure 11, Item 35) firmly while assistant pushes inner tube (Figure 11, Item 33) into outer tube approximately 12 in. (305 mm). Hold outer tube so piston assembly is centered in tool while assistant pulls inner tube in and out in short strokes as if using a slide hammer to pull piston assembly into cylinder (Figure 11, Item 54) past tool CAS1704-2.
- 39. Remove tool CAS1704-2 from lift cylinder assembly (Figure 9).

**NOTE**

To prevent damage to tools CAS1704-1 and CAS1704-2, store in shipping container immediately after each use.

- 40. Use clean lubricating oil to lubricate ring assembly (Figure 11, Item 22), slide ring assembly over outer tube (Figure 11, Item 35), connect to cylinder (Figure 11, Item 54), and tighten after metal-to-metal contact.
- 41. Use clean lubricating oil to lubricate gland assembly (Figure 11, Item 46) and install on lift cylinder assembly (Figure 11, Item 11). Tighten after metal-to-metal contact.

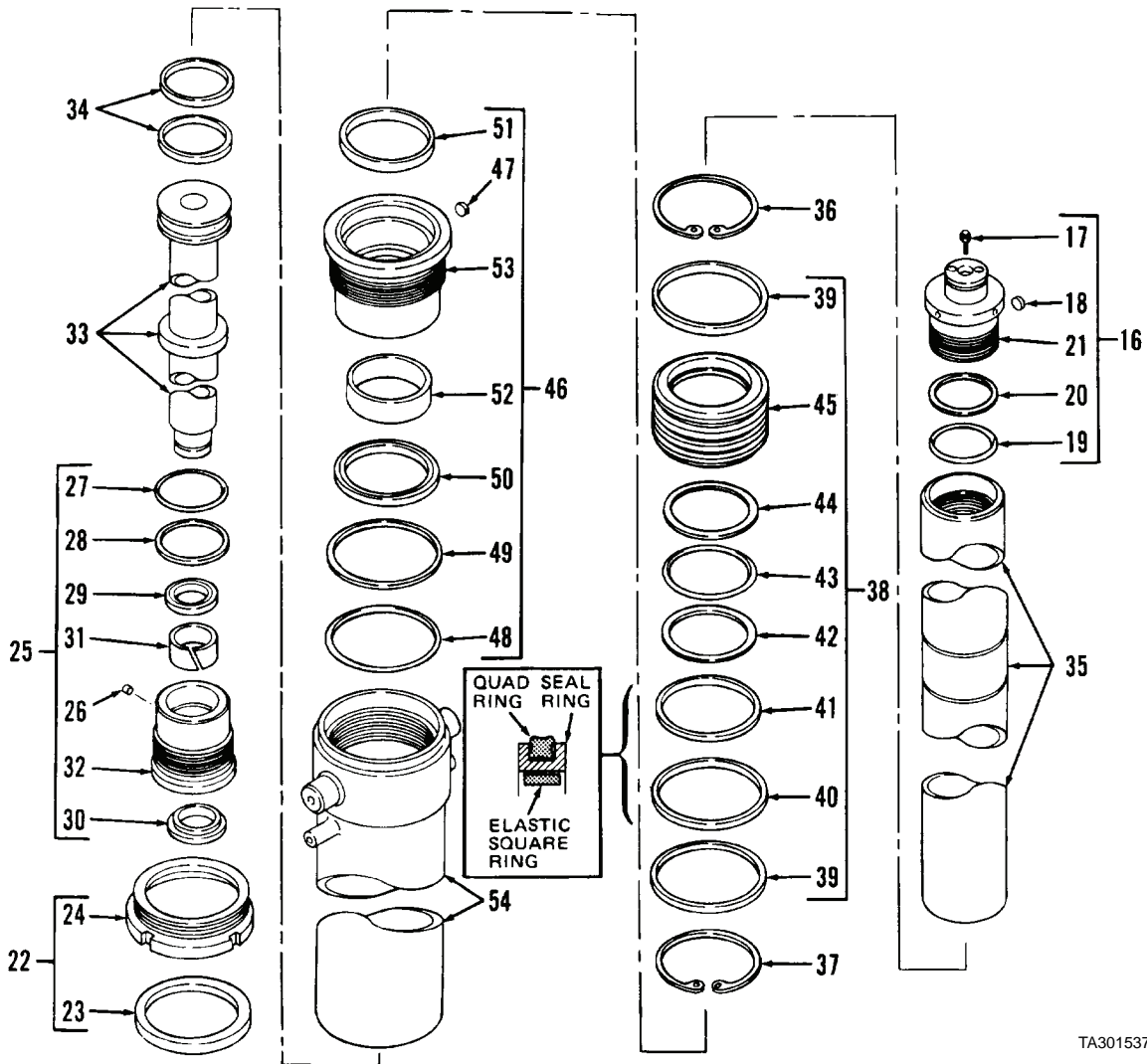

TA301537

Figure 11. Lift Cylinder.

**END OF TASK**

## INSTALLATION



**WARNING**



Be sure lift cylinder assembly is securely fastened to chain hoist. Failure to do so could cause lift cylinder assembly to fall, striking personnel and causing injury or death to personnel.

### CAUTION

Remove bleed screw to prevent damaging it when performing step 1.

### NOTE

Lift cylinder assembly chain trunnion roller spacers are offset from center; when installing lift cylinder assembly, be sure chain trunnion roller spacers are towards front of vehicle.

1. Position lift cylinder assembly (Figure 12, Item 11) upright using chain hoist and lower into channel pocket; if necessary, remove plug from port at bottom of cylinder.
2. Install retaining ring (Figure 12, Item 15) with square edge facing downwards and rounded edge facing upwards towards lift cylinder assembly.
3. Install restrictor (Figure 12, Item 14) with arrow pointing downwards, away from lift cylinder assembly (Figure 12, Item 11).
4. Install elbow (Figure 12, Item 13) on restrictor (Figure 12, Item 14).
5. Connect hose fitting (Figure 12, Item 12) and tighten.



**WARNING**

Keep hands and fingers clear of top of lift cylinder assembly when performing following step. Failure to do so could cause your fingers or hands to be caught between inner mast and lift cylinder assembly. You could lose a hand or finger.

6. Position guard (Figure 12, Item 11D) at bottom of outer mast (serial number 9150573 and above).
7. Install four washers (Figure 12, Item 11C), new lockwashers (Figure 12, Item 11B), and capscrews (Figure 12, Item 11A) and tighten capscrews (serial number 9150573 and above).
8. Use chain hoist to lower inner mast while guiding top of lift cylinder assembly into position at top of mast.
9. Install two washers (Figure 12, Item 10), spacers (Figure 12, Item 9), washers (Figure 12, Item 8), and capscrews (Figure 12, Item 7) on top of mast assembly. Tighten capscrews to 180 to 200 lb-ft (244 to 271 Nm).
10. Install safety wire (Figure 12, Item 6) through heads of capscrews, then twist ends together.
11. Install bleed screw (Figure 12, Item 17) in end cap (Figure 12, Item 21).
12. Install two chain pulleys (Figure 12, Item 4) and pulley bars (Figure 12, Item 5) on inner mast (WP 0193, *Installation/Replacement*, steps 5 through 9).
13. Position two lift chains (Figure 12, Item 3) over pulleys (Figure 12, Item 4).
14. Position four hose assemblies (Figure 12, Item 2) on vehicle.
15. Install two hose pulleys (Figure 12, Item 1) (WP 0193, *Installation/Replacement*, steps 12 through 15).
16. Perform WP 0195, *Bleeding Air from Lift Cylinder*, steps 1 through 8.

INSTALLATION - CONTINUED

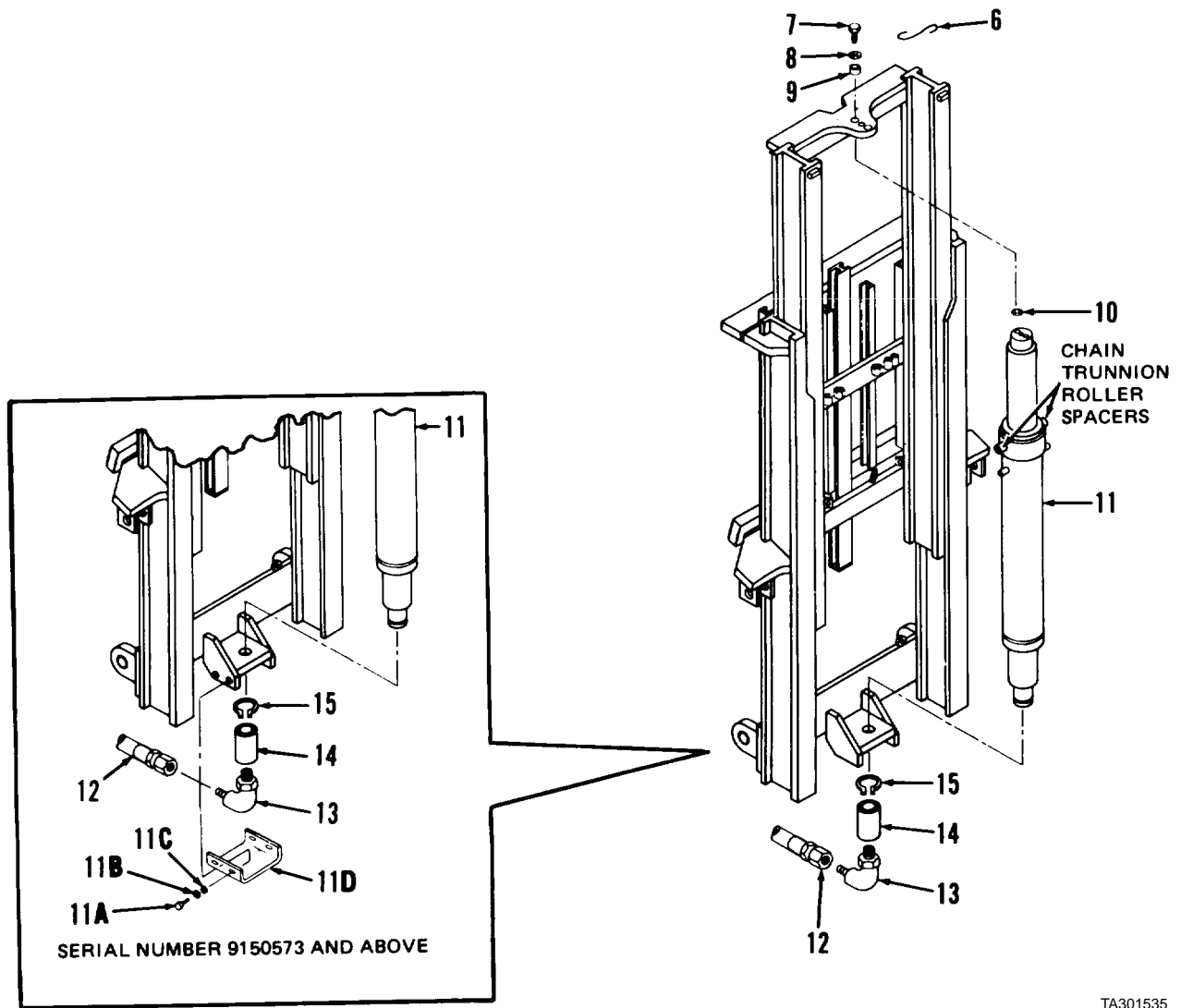

Figure 12. Mast.

END OF TASK

END OF WORK PACKAGE



---

## DIRECT SUPPORT MAINTENANCE INSTRUCTIONS

### CARRIAGE MAINTENANCE

Removal, Disassembly, Cleaning, Inspection/Repair, Assembly, Installation

---

#### INITIAL SETUP

##### Maintenance Level

Direct Support

##### Tools and Special Tools

Tool kit, general mechanic's (Item 15, WP 0309)

Bar, 1-1/2-in. diameter

Bar, 2-in. diameter

Bore gage, 0 to 4 in.

Chain hoist, 1/2-ton capacity

Micrometer, 0 to 4 in.

Wood blocks (2), 4 x 4 x 12 in.

##### Materials/Parts

Cleaning compound, solvent (Item 10, WP 0310)

##### Materials/Parts - Continued

Rag, wiping (Item 26, WP 0310)

Lockwasher (4)

##### Personnel Required

Two

##### Equipment Condition

Engine OFF

Parking brake applied

Carriage assembly raised approx. 4 in. from ground  
and securely blocked

Forks removed (WP 0192)

Sideshift chains disconnected from carriage assembly  
(WP 0194)

---

**REMOVAL**

1. Remove four capscrews (Figure 1, Item 1) and lockwashers (Figure 1, Item 2) from two retainers (Figure 1, Item 3). Discard lockwashers.
2. Remove two retainers (Figure 1, Item 3) from vehicle.

**WARNING**

Carriage travel bar weighs 134 lb (61 kg). Be careful not to injure yourself by travel bar falling on your feet or striking your legs.

**CAUTION**

Use chain hoist to support weight of carriage assembly to prevent damaging carriage travel bar.

3. Remove carriage travel bar (Figure 1, Item 4). Use 2-in. diameter bar and hammer to drive from side shifter.
4. Use chain hoist to remove carriage assembly (Figure 1, Item 11).

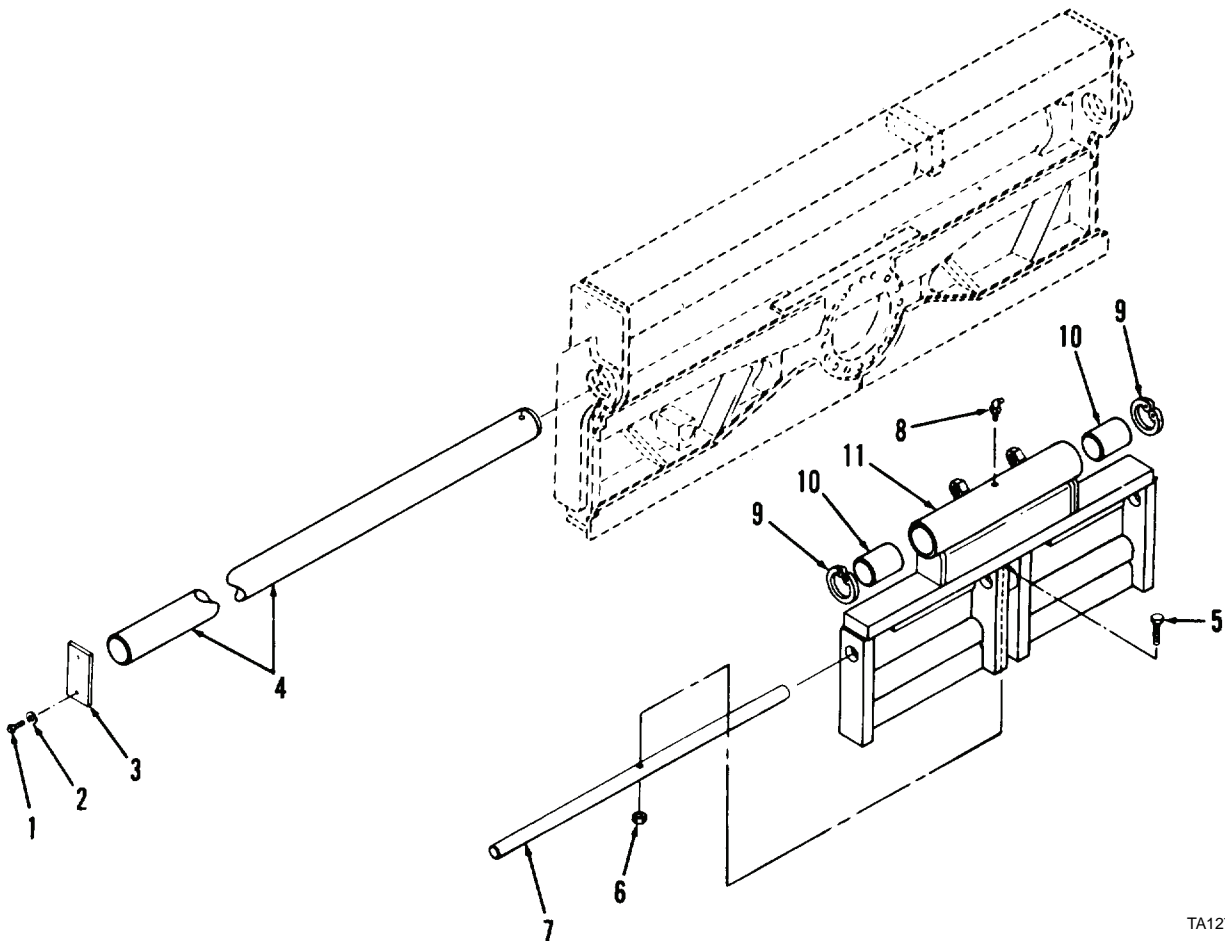

Figure 1. Carriage.

TA127186

**END OF TASK**



**DISASSEMBLY**

1. Remove capscrew (Figure 1, Item 5) and nut (Figure 1, Item 6) from center of carriage assembly (Figure 1, Item 11).
2. Use 1-1/2-in. diameter bar and hammer to drive fork travel bar (Figure 1, Item 7) from carriage assembly (Figure 1, Item 11).
3. Remove lubrication fitting (Figure 1, Item 8) from carriage assembly (Figure 1, Item 11).

**NOTE**

Do not remove snap rings or bushings unless inspection indicates replacement is necessary.

4. Remove two snap rings (Figure 1, Item 9) from carriage assembly (Figure 1, Item 11).
5. Remove two bushings (Figure 1, Item 10) from carriage assembly (Figure 1, Item 11).

**END OF TASK****CLEANING****WARNING**

Solvent cleaning compound MIL-PRF-680 Type III is an environmentally compliant and low toxic material. However, it may be irritating to the eyes and skin. Use protective gloves and goggles. Use in well-ventilated areas. Keep away from open flames and other sources of ignition. Failure to do so may result in injury or death to personnel.

Use solvent cleaning compound to clean all parts. Dry thoroughly.

**END OF TASK****INSPECTION/REPAIR**

1. Inspect carriage travel bar (Figure 1, Item 4). Replace if excessively worn in one area, bent, or deformed.
2. Inspect fork travel bar (Figure 1, Item 7). Replace if excessively worn in one area, bent, deformed, or cracked.
3. Inspect overall carriage assembly (Figure 1, Item 11). Replace or repair by welding if cracked, broken, or structurally damaged.
4. Inspect bushings (Figure 1, Item 10). Replace if worn; use bore gage and measure inside diameter. Replace if measurement is more than 3 in. (76 mm).
5. Inspect all other parts. Replace if damaged, cracked, or worn.

**END OF TASK**

**ASSEMBLY**

1. Install two bushings (Figure 2, Item 10), if removed, on carriage assembly (Figure 2, Item 11) until seated.
2. Install two snap rings (Figure 2, Item 9) in ring groove, if removed.
3. Install fork traveler bar (Figure 2, Item 7) in bore, using 1-1/2-in. diameter bar to drive into carriage assembly (Figure 2, Item 11).
4. Install lubrication fitting (Figure 2, Item 8) on carriage assembly (Figure 2, Item 11).
5. Install capscrew (Figure 2, Item 5) and nut (Figure 2, Item 6) in center of carriage assembly (Figure 2, Item 11). If holes are not aligned, tap fork traveler bar (Figure 2, Item 7) until holes line up.

**END OF TASK****INSTALLATION/REPLACEMENT**

1. Use chain hoist to position carriage assembly (Figure 2, Item 11) and align with side shifter frame.
2. Install carriage travel bar (Figure 2, Item 4) in bore, using 2-in. diameter bar to drive into side shifter frame and then into carriage assembly (Figure 2, Item 11) bore. Be sure bores align.
3. Position two retainers (Figure 2, Item 3) and install four capscrews (Figure 2, Item 1) and new lockwashers (Figure 2, Item 2).

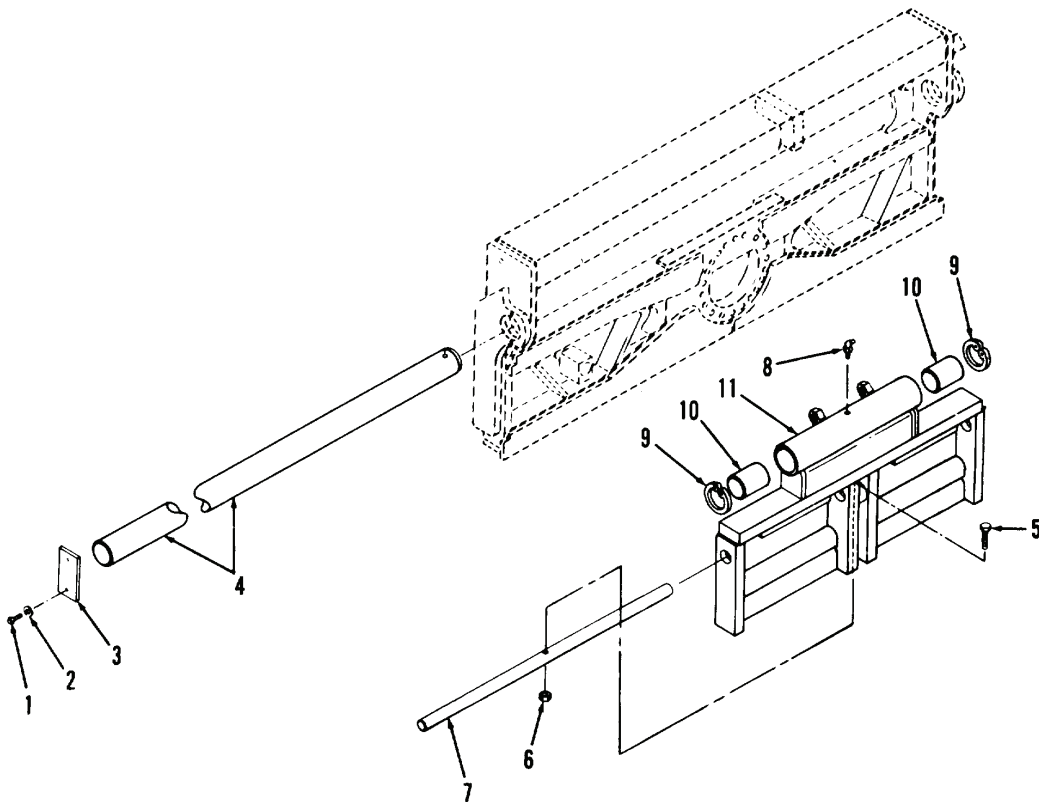
**Figure 2. Carriage.**

TA127186

4. Remove wood blocks and lower forks to ground.

**END OF TASK****END OF WORK PACKAGE**

---

## DIRECT SUPPORT MAINTENANCE INSTRUCTIONS

### SIDE SHIFTER FRAME AND ROTATION BEARING MAINTENANCE

Removal, Cleaning, Inspection/Repair, Installation/Replacement

---

#### INITIAL SETUP

##### Maintenance Level

Direct Support

##### Tools and Special Tools

Tool kit, general mechanic's (Item 15, WP 0309)

Chain hoist, 1/2-ton capacity

Steel horses (2)

Tap, 5/8-11 UNC 2B

##### Materials/Parts

Cleaning compound, solvent (Item 10, WP 0310)

Grease, automotive and artillery (Item 17, WP 0310)

Rag, wiping (Item 26, WP 0310)

##### Personnel Required

Two

##### References

LO 10-3930-638-12

##### References - Continued

WP 0192

WP 0193

WP 0194

WP 0196

WP 0197

WP 0264

WP 0265

##### Equipment Condition

Fork assembly grounded

Mast assembly in vertical position

Hoses, lines, and fittings between control valve and mast assembly, disconnected at mast assembly and lift cylinder assembly (WP 0195)

Front axle tires and wheels removed (WP 0169)

Carriage assembly removed (WP 0267)

---

**REMOVAL**

1. Attach chain hoist to top of inner mast and take up all slack.

**WARNING**

Before performing the following steps, be sure mast assembly is securely supported by chain hoist. Failure to do so will cause mast assembly to pivot mast pin which may result in injury to personnel.

2. Remove four retaining rings (Figure 1, Item 1) from mast assembly.
3. Remove two pins (Figure 1, Item 2) from mast assembly.
4. Position tilt cylinder assemblies.
5. Loosen two nuts (Figure 1, Item 3).
6. Use 10 lb (4.5 kg) hammer to tap two lower pivot mast pins (Figure 1, Item 5) to loosen.
7. Remove two nuts (Figure 1, Item 3) and washers (Figure 1, Item 4) from mast assembly.
8. Remove two lower pivot mast pins (Figure 1, Item 5) and washers (Figure 1, Item 6) from mast assembly.
9. Remove two lubrication fittings (Figure 1, Item 7) from lower pivot mast pins (Figure 1, Item 5).
10. Remove mast assembly. Use chain hoist and move to work area. Position mast on two steel horses with side shifter frame facing up.
11. Remove rotation cylinder assembly (WP 0265).
12. Remove sideshift cylinder assembly (WP 0264).
13. Remove two sideshift chains and pulleys (WP 0194).
14. Center side shifter frame (Figure 1, Item 11).
15. Remove 20 capscrews (Figure 1, Item 8), nuts (Figure 1, Item 9), and washers (Figure 1, Item 10).
16. Secure chain hoist to side shifter frame.

**WARNING**

Be sure chain hoist is securely attached to side shifter frame before performing step 17. Failure to do so could cause frame to fall, causing injury to personnel.

17. Remove side shifter frame (Figure 1, Item 11) from vehicle.

**NOTE**

If capscrews are difficult to remove in step 18, heat capscrews, then remove and discard.

18. Remove 16 capscrews (Figure 1, Item 12) from carriage bearing plate (Figure 1, Item 14).
19. Remove rotation bearing (Figure 1, Item 13) from vehicle.
20. Remove four hose assemblies (WP 0196 or WP 0197).
21. Remove four tube assemblies (WP 0196 or WP 0197).
22. Disconnect two lift chains connected to carriage bearing plate (WP 0193).
23. Move carriage bearing plate (Figure 1, Item 14) halfway out of inner mast.
24. Secure sling hoist to carriage bearing plate (Figure 1, Item 14).

REMOVAL - CONTINUED

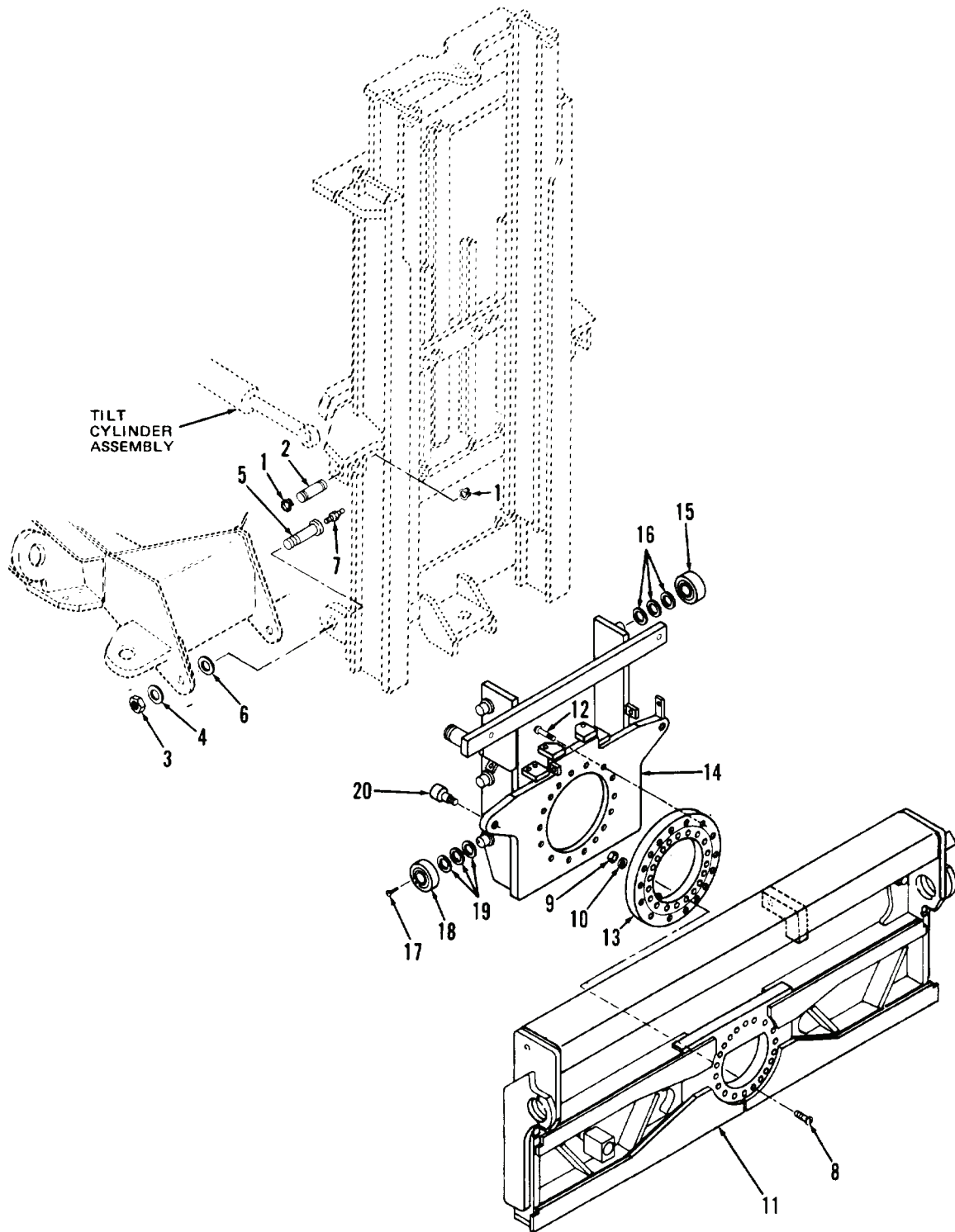

TA127187

Figure 1. Side Shifter Frame and Rotation Bearing.

**REMOVAL - CONTINUED****WARNING**

Be sure sling hoist is securely fastened to carriage bearing plate before performing step 25. Failure to do so may result in injury to personnel.

**CAUTION**

Roller bearings and shims may fall off carriage bearing plate in step 25.

25. Use sling hoist to remove carriage bearing plate (Figure 2, Item 14).
26. Remove two roller bearings (Figure 2, Item 15) from carriage bearing plate (Figure 2, Item 14).
27. Remove shims (Figure 2, Item 16) from carriage bearing plate (Figure 2, Item 14).
28. Remove two capscrews (Figure 2, Item 17) from carriage bearing plate (Figure 2, Item 14).
29. Remove two roller bearings (Figure 2, Item 18) from carriage bearing plate (Figure 2, Item 14).
30. Remove shims (Figure 2, Item 19) from carriage bearing plate (Figure 2, Item 14).
31. Remove two cam rollers (Figure 2, Item 20) from carriage bearing plate (Figure 2, Item 14).

**END OF TASK****CLEANING****WARNING**

Solvent cleaning compound MIL-PRF-680 Type III is an environmentally compliant and low toxic material. However, it may be irritating to the eyes and skin. Use protective gloves and goggles. Use in well-ventilated areas. Keep away from open flames and other sources of ignition. Failure to do so may result in injury or death to personnel.

**CAUTION**

Do not immerse roller bearings or rotation bearing in solvent cleaning compound.

Use solvent cleaning compound to clean parts except for roller bearings (Figure 2, Items 15 and 18) and rotation bearing (Figure 2, Item 13). Dry thoroughly.

CLEANING - CONTINUED

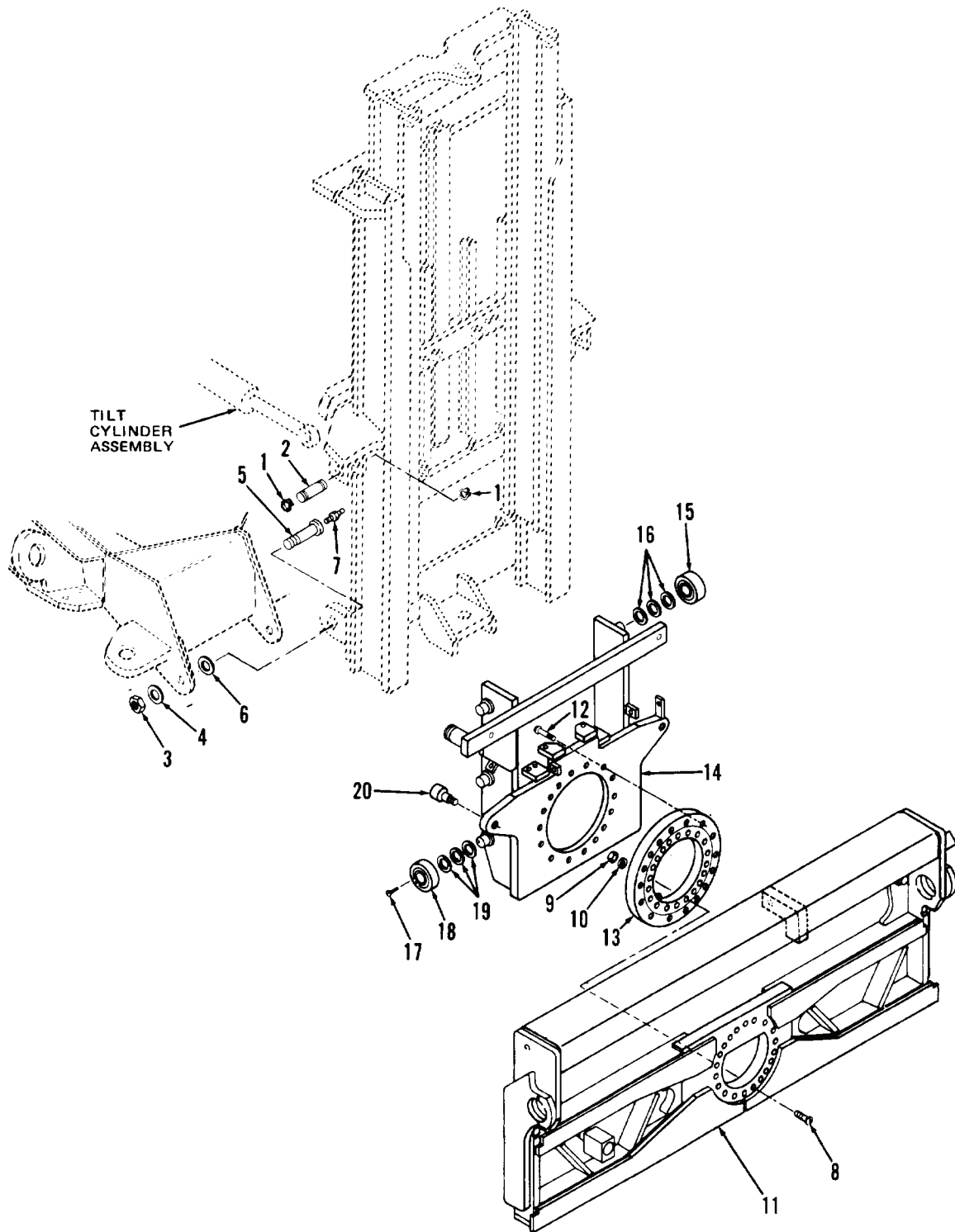

Figure 2. Side Shifter Frame and Rotation Bearing.

TA127187

END OF TASK

## INSPECTION/REPAIR

1. Inspect lower pivot mast pin (Figure 3, Item 5). Replace if bent or distorted, threads damaged or worn.
2. Inspect roller bearings (Figure 3, Items 15 and 18) and cam roller (Figure 3, Item 20). Replace if out of round, scored, burred, sharp-edged, or worn.
3. Inspect side shifter frame (Figure 3, Item 11) and carriage bearing plate (Figure 3, Item 14). Replace or repair by welding if cracked, broken, or structurally damaged. Replace if bent or warped.
4. Inspect rotation bearings (Figure 3, Item 13). Replace if out of round, scored, burred, worn, or distorted. Repair damaged threads by chasing with 5/8-11 UNC 2B tap.
5. Inspect all other parts. Replace if damaged, worn, cracked, or distorted.

## END OF TASK

## INSTALLATION/REPLACEMENT

1. Install two cam rollers (Figure 3, Item 20) on carriage bearing plate (Figure 3, Item 14).
2. Install shims (Figure 3, Item 19), four roller bearings (Figure 3, Item 18), and two capscrews (Figure 3, Item 17) on two bottom roller bearings.
3. Install shims (Figure 3, Item 16) and two roller bearings (Figure 3, Item 15) on carriage bearing plate (Figure 3, Item 14).
4. Attach sling hoist to carriage bearing plate (Figure 3, Item 14).



## WARNING

Be sure sling hoist is securely fastened to carriage bearing plate before performing step 5. Failure to do so may result in injury to personnel.

## CAUTION

Roller bearings and shims may fall off carriage bearing plate when performing step 5.

5. Install carriage bearing plate (Figure 3, Item 14) on vehicle. Use sling hoist. Depress locking pin and position half way into inner mast, then remove sling hoist.
6. Move carriage bearing plate (Figure 3, Item 14) into full position.
7. Connect two lift chains to carriage bearing plate (Figure 3, Item 14) (WP 0193).
8. Install four tube assemblies (WP 0196 or WP 0197).
9. Install four hose assemblies (WP 0196 or WP 0197).
10. Position rotation bearing (Figure 3, Item 13) on carriage bearing plate (Figure 3, Item 14).
11. Install 16 capscrews (Figure 3, Item 12) on carriage bearing plate (Figure 3, Item 14) and rotation bearing (Figure 3, Item 13).
12. Secure chain hoist to side shifter frame (Figure 3, Item 11).



INSTALLATION/REPLACEMENT - CONTINUED

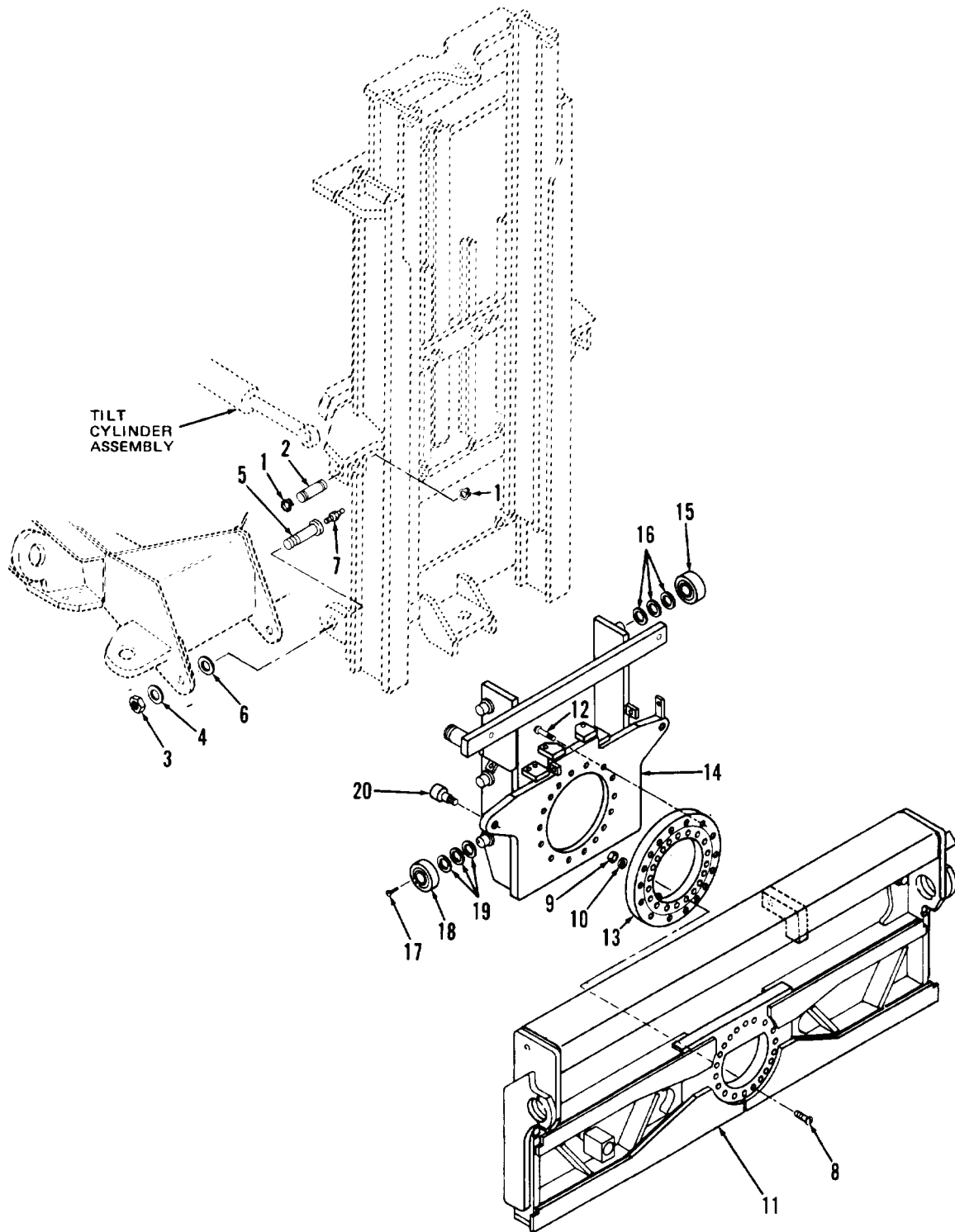

Figure 3. Side Shifter Frame and Rotation Bearing.

TA127187

**INSTALLATION/REPLACEMENT - CONTINUED****WARNING**

Be sure chain hoist is securely attached to side shifter frame before performing step 13. Failure to do so may result in injury to personnel.

13. Position side shifter frame (Figure 4, Item 11) on rotation bearings (Figure 4, Item 13) and align holes in side shifter frame with holes in rotation bearing (Figure 4, Item 13).
14. Install 20 capscrews (Figure 4, Item 8), washers (Figure 4, Item 10), and nuts (Figure 4, Item 9).
15. Remove chain hoist from side shifter frame.
16. Install sideshift cylinder assembly (WP 0264).
17. Install two sideshift chains and pulleys (WP 0194).
18. Install rotation cylinder assembly (WP 0265, *Installation*, step 11).
19. Install carriage assembly (WP 0267, *Installation*, step 11).
20. Attach chain hoist to top of inner mast.

**WARNING**

Be sure chain hoist is securely fastened to top of inner mast before performing step 21. Failure to do so may result in injury to personnel.

21. Position mast assembly on vehicle and align mounting holes.

**NOTE**

Use chassis grease to hold washers in position if necessary.

22. Install two washers (Figure 4, Item 6) and lower pivot mast pins (Figure 4, Item 5) on mast assembly sides.
23. Install two washers (Figure 4, Item 4) and nuts (Figure 4, Item 3).
24. Install two lubrication fittings (Figure 4, Item 7) on lower pivot mast pins (Figure 4, Item 5).
25. Position eye on rod end of tilt cylinder assemblies between brackets on outer mast sides.
26. Install two pins (Figure 4, Item 2) on mast and tilt cylinder eye.
27. Install four retaining rings (Figure 4, Item 1) on two pins (Figure 4, Item 2).

## INSTALLATION/REPLACEMENT - CONTINUED

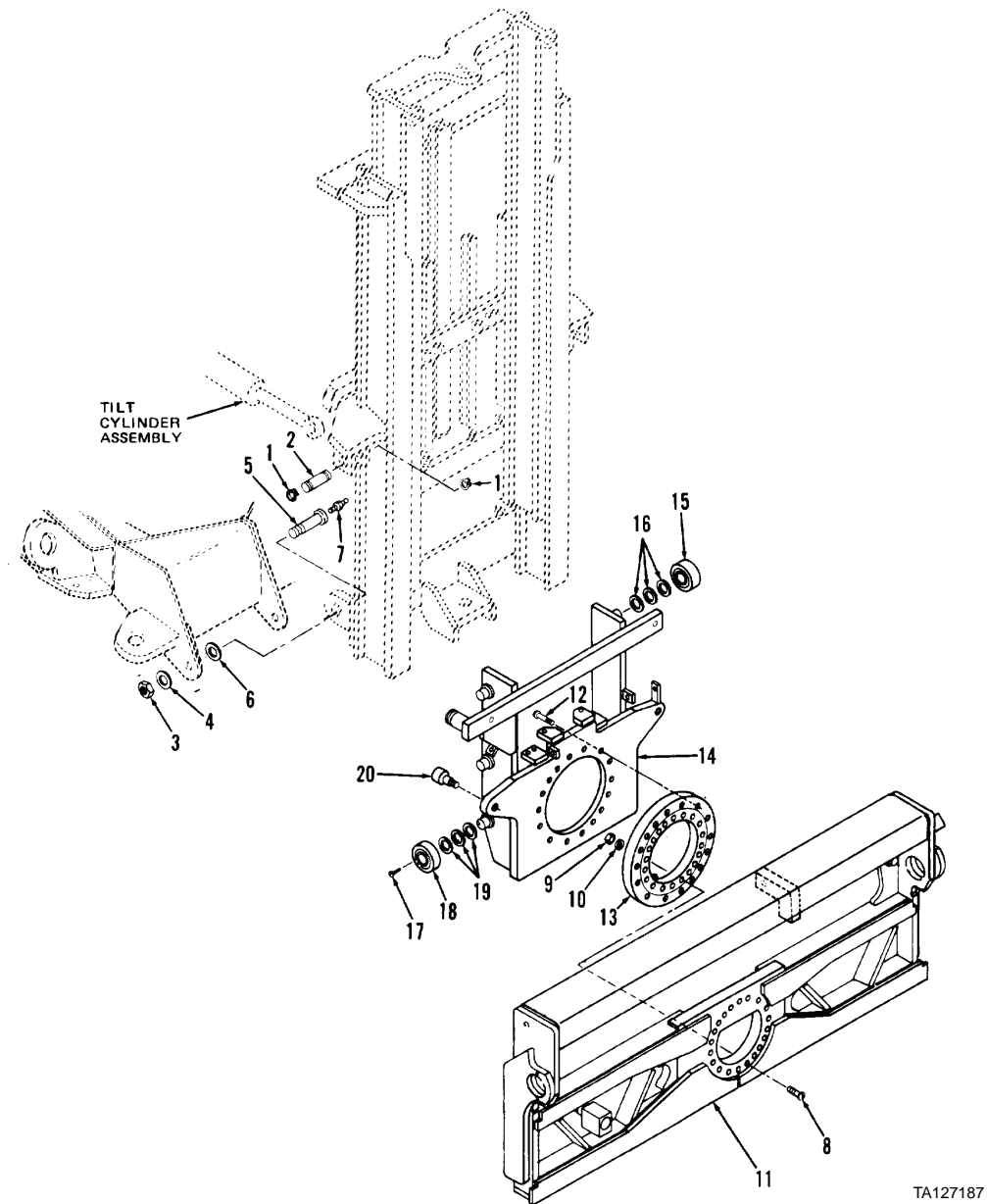

**Figure 4. Side Shifter Frame and Rotation Bearing.**

28. Adjust lift chains (WP 0193).
29. Connect hoses, lines, and fittings (WP 0195).
30. Install front axle tires and wheels (WP 0169).
31. Lubricate lubrication fittings (Figure 4, Item 7) and rotation bearing (Figure 4, Item 13) (LO 10-3930-638-12).
32. Install forks (WP 0192).

**END OF TASK**

**END OF WORK PACKAGE**



---

## DIRECT SUPPORT MAINTENANCE INSTRUCTIONS

### INNER AND OUTER MAST MAINTENANCE

Removal, Cleaning, Inspection/Repair, Installation/Replacement

---

#### INITIAL SETUP

**Maintenance Level**

Direct Support

**Tools and Special Tools**

Tool kit, general mechanic's (Item 15, WP 0309)

Chain hoist, 1/2-ton capacity

**Materials/Parts**

Cleaning compound, solvent (Item 10, WP 0310)

Rag, wiping (Item 26, WP 0310)

Lockwasher (2)

**Personnel Required**

Two

**Equipment Condition**

Side shifter frame and rotation bearing removed  
(WP 0268)

Lift cylinder assembly removed (WP 0266)

Hose and tube assemblies removed (WP 0196 or  
WP 0197)

Two lift chains and pulleys removed (WP 0193)

---

**REMOVAL**

1. Remove two stop bolts (Figure 1, Item 1) and lockwashers (Figure 1, Item 2) from outer mast (Figure 1, Item 12). Discard lockwashers.
2. Slide outer mast (Figure 1, Item 12) until bottom roller bearings (Figure 1, Item 4) are in line with cut-outs in sides of outer mast.
3. Attach chain hoist to inner mast (Figure 1, Item 3) at approximate center and take up slack.

**WARNING**

Be sure chain hoist is securely fastened to inner mast before performing step 4. Failure to do so may result in injury by mast falling on you.

4. Push down at top of inner mast (Figure 1, Item 3) to disengage roller bearings (Figure 1, Item 4) from outer mast (Figure 1, Item 12), while lifting inner mast using chain hoist. Remove inner mast from vehicle.
5. Remove two roller bearings (Figure 1, Item 4) and shims (Figure 1, Item 5) from inner mast (Figure 1, Item 3).
6. Remove roll pin (Figure 1, Item 6) from spring retainer (Figure 1, Item 7).
7. Remove spring retainer (Figure 1, Item 7) from inner mast (Figure 1, Item 3).
8. Remove spring (Figure 1, Item 8) from inner mast (Figure 1, Item 3).
9. Remove lock pin (Figure 1, Item 9) from inner mast (Figure 1, Item 3).
10. Remove two roller bearings (Figure 1, Item 10) and shims (Figure 1, Item 11) from outer mast (Figure 1, Item 12).
11. Remove three nuts (Figure 1, Item 13), six washers (Figure 1, Item 14), and three capscrews (Figure 1, Item 15) from hose channels (Figure 1, Items 16, 17, and 18).
12. Remove left hose channel (Figure 1, Item 16) from vehicle.
13. Remove center hose channel (Figure 1, Item 17) from vehicle.
14. Remove right hose channel (Figure 1, Item 18) from vehicle.
15. Remove three roll pins (Figure 1, Item 19) from outer mast (Figure 1, Item 12).

**END OF TASK****CLEANING****WARNING**

Solvent cleaning compound MIL-PRF-680 Type III is an environmentally compliant and low toxic material. However, it may be irritating to the eyes and skin. Use protective gloves and goggles. Use in well-ventilated areas. Keep away from open flames and other sources of ignition. Failure to do so may result in injury or death to personnel.

**CAUTION**

Do not immerse roller bearings in solvent cleaning compound.

Use solvent cleaning compound to clean parts except for roller bearings (Figure 1, Items 4 and 10). Dry thoroughly.

CLEANING - CONTINUED

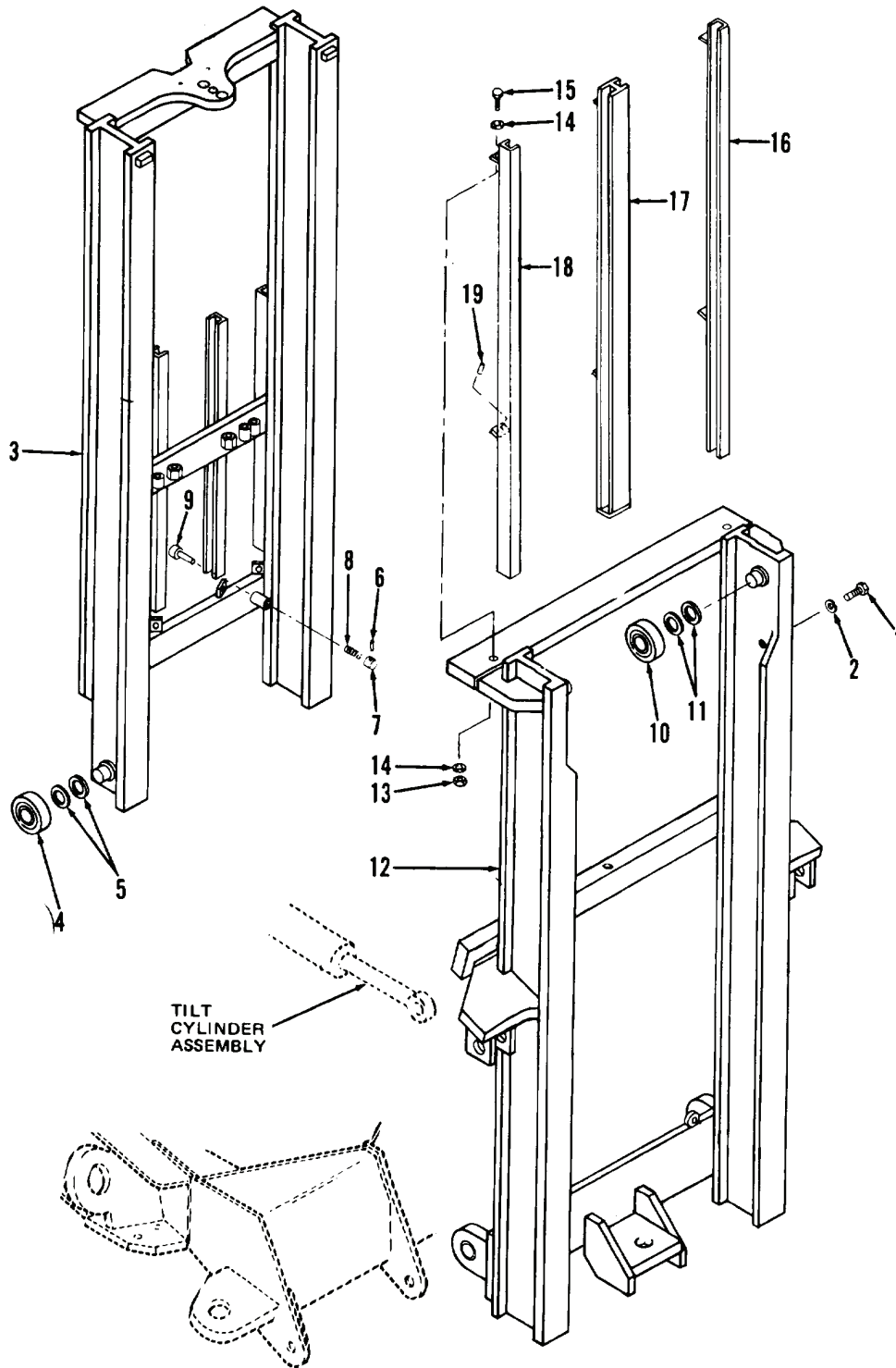

Figure 1. Inner and Outer Mast.

TA12788

END OF TASK

## INSPECTION/REPAIR

1. Inspect inner mast (Figure 2, Item 3), outer mast (Figure 2, Item 12), and hose channels (Figure 2, Items 16, 17, and 18). Replace or repair by welding if cracked, broken, or structurally damaged. Replace if twisted or bent out of shape and if roller bearing posts are out-of-round or worn.
2. Inspect roller bearings (Figure 2, Items 4 and 10). Replace if out-of-round (inside and outside diameters), worn, or damaged.
3. Inspect roll pins (Figure 2, Items 6 and 19). Replace if bent.
4. Inspect spring retainer (Figure 2, Item 7) and lock pin (Figure 2, Item 9). Replace if damaged, bent, or worn.
5. Inspect spring (Figure 2, Item 8). Replace if damaged, distorted, or permanent set is noticed.
6. Inspect all other parts. Replace if damaged, worn, or threads damaged.

## END OF TASK

## INSTALLATION/REPLACEMENT

1. Install three roll pins (Figure 2, Item 19) on outer mast (Figure 2, Item 12).
2. Position hose channels (Figure 2, Items 16, 17, and 18) on vehicle.
3. Install three capscrews (Figure 2, Item 15), six washers (Figure 2, Item 14), and three nuts (Figure 2, Item 13) on hose channels (Figure 2, Items 16, 17, and 18).
4. Position shims (Figure 2, Item 11) and install two roller bearings (Figure 2, Item 10) on outer mast.
5. Position lock pin (Figure 2, Item 9), spring (Figure 2, Item 8), and spring retainer (Figure 2, Item 7) on inner mast (Figure 2, Item 3).
6. Install roll pin (Figure 2, Item 6) on spring retainer (Figure 2, Item 7).
7. Position shims (Figure 2, Item 5) on roller bearing posts and install two roller bearings (Figure 2, Item 4).
8. Attach chain hoist to approximate center of inner mast (Figure 2, Item 3).



## WARNING

Be sure chain hoist is securely fastened to inner mast before performing step 9. Failure to do so may result in injury to personnel.

9. Install inner mast (Figure 2, Item 3) on vehicle. Position inner mast so roller bearings are in line with cut-outs in sides of outer mast. Lift top of inner mast to slip roller bearings into channel of outer mast while lowering inner mast. Push inner mast into outer mast halfway.
10. Remove chain hoist.
11. Position inner mast (Figure 2, Item 3) completely in outer mast (Figure 2, Item 12).
12. Install two new lockwashers (Figure 2, Item 2) and stop bolts (Figure 2, Item 1) on outer mast (Figure 2, Item 12).



INSTALLATION/REPLACEMENT - CONTINUED

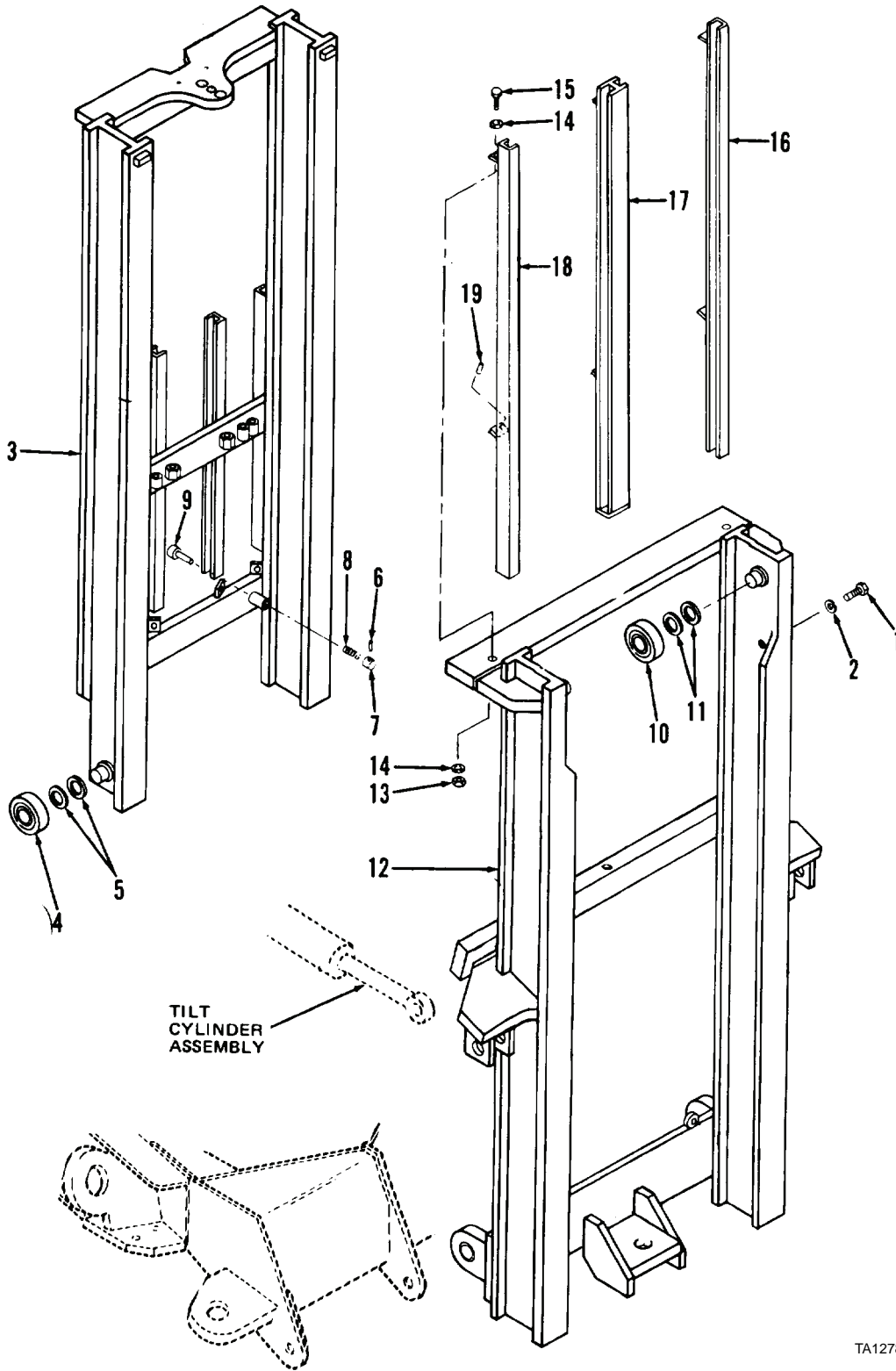

TA12788

Figure 2. Inner and Outer Mast.

END OF TASK  
END OF WORK PACKAGE



**CHAPTER 6**  
**GENERAL SUPPORT MAINTENANCE INSTRUCTIONS**



---

## GENERAL SUPPORT MAINTENANCE INSTRUCTIONS

### CYLINDER BLOCK REPAIR (MODEL 207)

#### Disassembly, Cleaning, Inspection, Assembly

---

#### INITIAL SETUP

##### Maintenance Level

General Support

##### Tools and Special Tools

Tool kit, general mechanic's (Item 15, WP 0309)  
 Shop equipment, common no. 1 (Item 2, WP 0309)  
 Ball (P/N A142802)  
 Bore gage, 0 to 5 in.  
 Brass wire probe  
 Clamping bar (P/N A40682)  
 Clamping disc (P/N A142802)  
 Micrometer, 0 to 5 in.  
 Sleeve, 3-3/16-in. diameter  
 Sleeve, 3/4-in. diameter  
 Sleeve, 1-in. diameter  
 Steel straightedge (P/N CAS-1369A)  
 Thickness gage (NSN 5210-00-221-1999)  
 Wire, 0.020-in. diameter

##### Materials/Parts

Cleaning compound, solvent (Item 10, WP 0310)

##### Materials/Parts - Continued

Lubricating oil, OE/HDO-15/40 (Item 21, WP 0310)  
 Prussian blue (Item 25, WP 0310)  
 Rag, wiping (Item 26, WP 0310)  
 Permatex (Item 30, WP 0310)  
 Blue vitriol solution  
 Dry ice  
 Paint  
 Lockwasher  
 O-ring (2)

##### Equipment Condition

Cylinder head removed (WP 0218)  
 Oil drain removed (WP 0226)  
 Timing gear cover removed (WP 0284)  
 Oil pump removed (WP 0286)  
 Flywheel and flywheel housing removed (WP 0278)  
 Crankshaft oil seal retainer removed (WP 0274)  
 Crankshaft and main bearings removed (WP 0276)

---

**DISASSEMBLY**

**NOTE**

Remove cylinder sleeves only if inspection indicates removal/replacement is necessary.

1. Identify cylinder sleeve (Figure 1, Item 1) and number and mark for position in relation to block if sleeves may be reinstalled. Use paint.

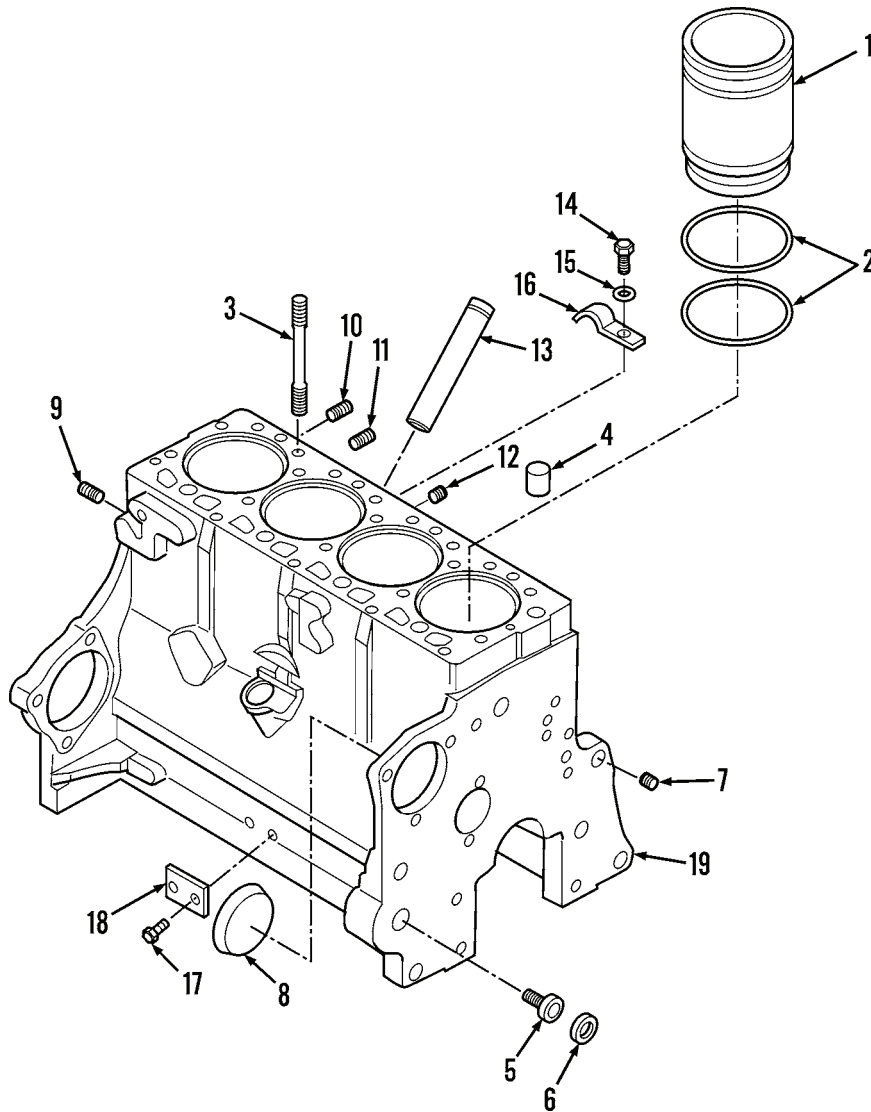

444-1302

**Figure 1. Engine Cylinder Block.**

**DISASSEMBLY - CONTINUED**

2. Remove two O-rings (Figure 1, Item 2) from cylinder sleeve (Figure 1, Item 1). Discard O-rings.
3. Remove stud (Figure 1, Item 3) from cylinder block (Figure 1, Item 19).
4. Remove dowel ring (Figure 1, Item 4) from cylinder block (Figure 1, Item 19).
5. Remove oil filter-to-block adapter (Figure 1, Item 5) and plug (Figure 1, Item 6) from cylinder block (Figure 1, Item 19). Use hammer and tap adapter. Plug will be forced out of block with adapter.
6. Remove oil gallery plug (Figure 1, Item 7) from cylinder block (Figure 1, Item 19).
7. Use 3-3/16-in. diameter sleeve to remove cup plug (Figure 1, Item 8) from cylinder block (Figure 1, Item 19).
8. Remove plug (Figure 1, Item 9) from cylinder block (Figure 1, Item 19).
9. Remove plugs (Figure 1, Items 10, 11, and 12) from cylinder block (Figure 1, Item 19).
10. Remove dipstick tube (Figure 1, Item 13) from cylinder block (Figure 1, Item 19).
11. Remove screw (Figure 1, Item 14) and lockwasher (Figure 1, Item 15) from clip (Figure 1, Item 16) and remove clip from cylinder block (Figure 1, Item 19). Discard lockwasher.
12. Remove two screws (Figure 1, Item 17) from plate (Figure 1, Item 18) and remove plate from cylinder block (Figure 1, Item 19).

**END OF TASK****CLEANING****WARNING**

- Solvent cleaning compound MIL-PRF-680 Type III is an environmentally compliant and low toxic material. However, it may be irritating to the eyes and skin. Use protective gloves and goggles. Use in well-ventilated areas. Keep away from open flames and other sources of ignition. Failure to do so may result in injury or death to personnel.
  - Particles blown by compressed air are hazardous. DO NOT exceed 15 PSI (103 kPa) nozzle pressure when drying parts with compressed air. DO NOT exceed 30 psi (207 kPa) nozzle pressure when cleaning parts with compressed air. DO NOT direct compressed air against human skin. Make sure air stream is directed away from user and other personnel in the area. To prevent injury, user must wear protective goggles or face shield. Failure to follow this warning may result in injury to personnel.
1. Clean cylinder and crankcase oil passages thoroughly using moisture-free compressed air and brass wire probe. Clean exterior with live steam. Clean upper and lower cylinder grooves, oil galleries, and drain openings thoroughly. Clean camshaft bushing bores thoroughly. Use 0.020-in. wire to clean camshaft bushing bore jets. Dry thoroughly with moisture-free compressed air.
  2. Use solvent cleaning compound to clean cylinder sleeves (Figure 1, Item 1). Dry thoroughly with moisture-free compressed air or clean rags.
  3. Clean all other parts by immersing in solvent cleaning compound. Dry thoroughly with moisture-free compressed air or clean rags.

**END OF TASK**

## INSPECTION

1. Inspect cylinder block (Figure 2, Item 19). Replace if cracked, damaged, worn, eroded, or distorted or if grooves and lands pitted or eroded.
2. Use straightedge and feeler gage to measure top surface. If surface varies more than 0.002 in. (0.05 mm), replace block.
3. Measure cylinder sleeve bores. Check taper and out-of-roundness with bore gage. If taper or out-of roundness exceeds 0.002 in. (0.05 mm), replace block.
4. Inspect cylinder sleeve (Figure 2, Item 1). Replace if smooth, shiny surface along complete length or heavy vertical lines fringed by metal transferring from one spot to another are observed.



**WARNING**



Blue vitriol solution contains acid. Wear safety glasses to protect eyes from accidental splashing and avoid splashing solution on skin. If solution is splashed on your skin or in your eyes, wash off immediately with water and get medical aid. Failure to do so may result in injury to personnel.

## NOTE

If blue vitriol solution cannot be obtained from druggist, a satisfactory solution can be made from copper sulfate crystals available at hobby stores or pharmacies. To prepare solution: add 1 tablespoon fresh battery acid to 1 cup water; add 1/2 level teaspoon copper sulfate crystals to solution; stir with plastic spoon until crystals are dissolved.

5. Check chrome plating. Wet inside of sleeve with cotton swab saturated with blue vitriol solution. If bright copper color is observed, replace sleeve. Rinse tested surfaces with water after check.
6. Check sleeve inside diameter for taper. Use inside micrometer or bore gage. Check below top ring location and at several points down length. Replace if taper is more than 0.002 in. (0.05 mm).
7. Check sleeve out-of-roundness. Use bore gage. Measure lengthwise just below top ring location at four points 90 degrees from each other. Replace if out-of-round from each other. Replace if out-of-roundness exceeds 0.001 in. (0.03 mm). (Use micrometer to check bore gage.)
8. Inspect oil filter-to-block adapter (Figure 2, Item 5) and stud (Figure 2, Item 3). Replace if bent or threads damaged.
9. Inspect dipstick tube (Figure 2, Item 13). Replace if bent, cracked, or dented.
10. Inspect dowel ring (Figure 2, Item 4). Replace if deformed or nicked.
11. Inspect all other parts. Replace if threads are damaged.



INSPECTION - CONTINUED

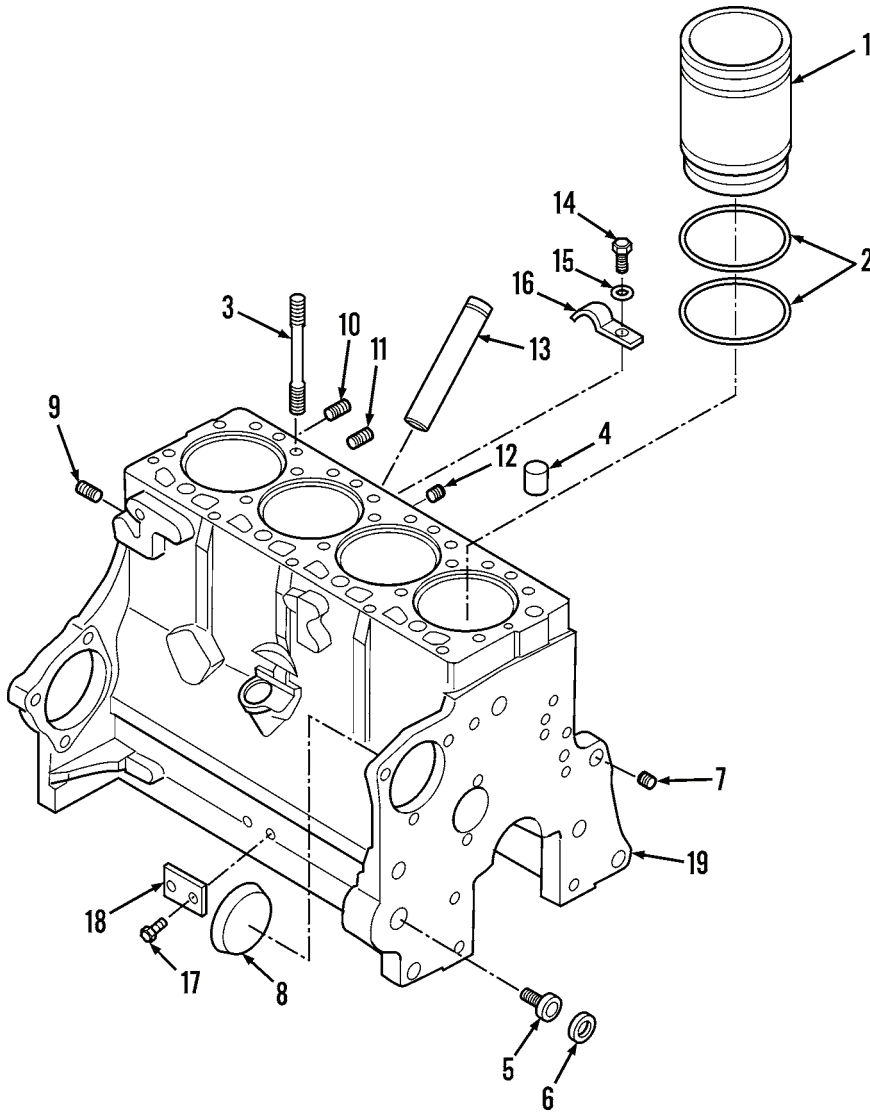

444-1302

Figure 2. Engine Cylinder Block.

END OF TASK

---

**ASSEMBLY**

1. Position plate (Figure 3, Item 18) on cylinder block (Figure 3, Item 19) and install two screws (Figure 3, Item 17).
2. Position clip (Figure 3, Item 16) on cylinder block (Figure 3, Item 19) and install new lockwasher (Figure 3, Item 15) and screw (Figure 3, Item 14).
3. Chill dipstick tube (Figure 3, Item 13) in dry ice and install smooth end in block until firmly seated.
4. Install plugs (Figure 3, Items 9, 10, 11, and 12) on cylinder block (Figure 3, Item 19).
5. Install cup plug (Figure 3, Item 8) from rear cylinder block (Figure 3, Item 19) until flush with front of block.
6. Install oil gallery plug (Figure 3, Item 7) on cylinder block (Figure 3, Item 19).
7. Use 3/4-in. diameter sleeve to install oil filter-to-block adapter (Figure 3, Item 5) in front of block.
8. Use 1-in. diameter sleeve to install plug (Figure 3, Item 6) in cylinder block (Figure 3, Item 19) with lip towards front of block.
9. Chill dowel ring (Figure 3, Item 4) in dry ice and install in cylinder block (Figure 3, Item 19).
10. Use clean engine oil to lubricate two new O-rings (Figure 3, Item 2) and install on cylinder sleeve (Figure 3, Item 1) in cylinder sleeve bottom grooves.
11. Clean upper and lower grooves of cylinder sleeve bore.

**NOTE**

If old sleeves are being reinstalled, install in same location and position as they were prior to removal.

12. Install cylinder sleeve (Figure 3, Item 1) on cylinder block (Figure 3, Item 19). Do not rotate sleeve during installation and be careful not to damage O-rings. Use hand pressure to install.

ASSEMBLY - CONTINUED

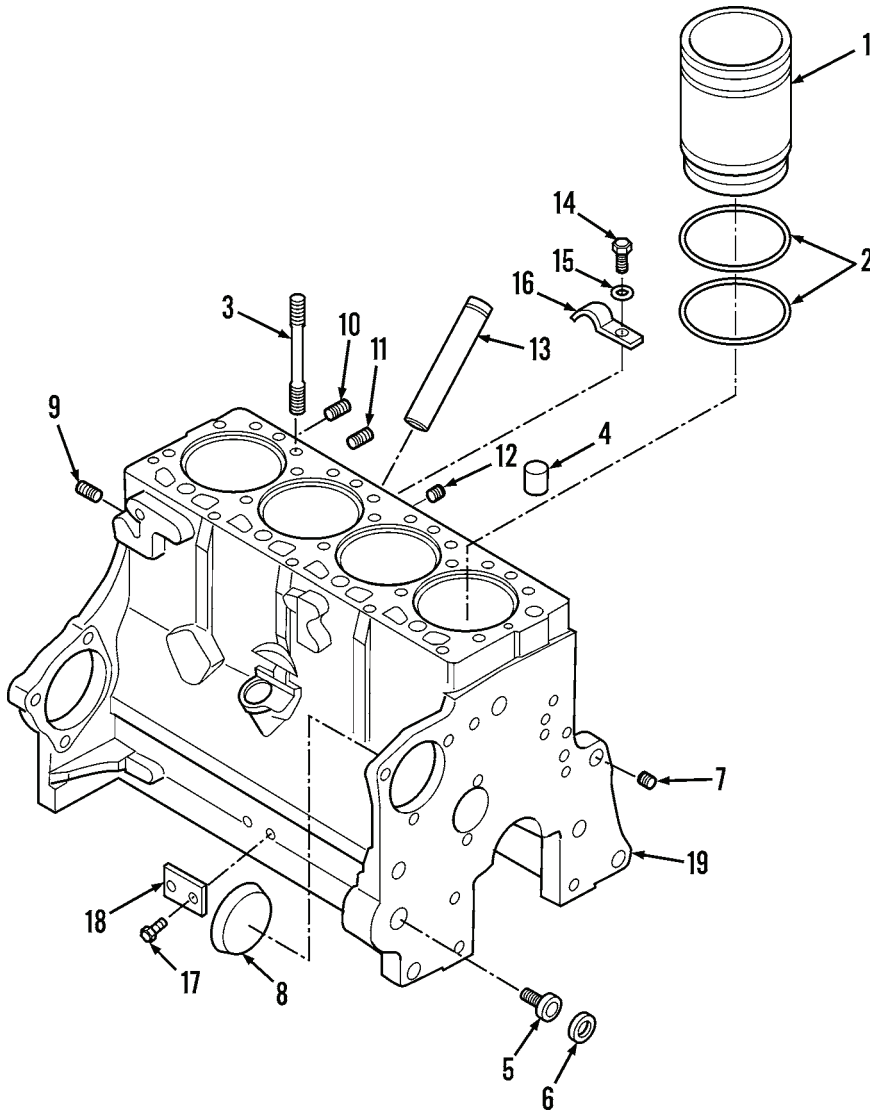

444-1302

Figure 3. Engine Cylinder Block.

**ASSEMBLY - CONTINUED**

13. Measure sleeve protrusion. Position plastigage at four points as shown (Figure 4). Plastigage must not protrude onto sleeve flange. Install clamping disc tool carefully over sleeve as shown. Install 1-in. ball and clamping bar. Tighten hold-down bolts evenly to 50 lb-ft (68 Nm). Then, remove clamping bolts, bar, and ball. Carefully remove clamping disc so as not to disturb plastigage. Flattened plastigage will be on clamping disc or block. Measure plastigage. If sleeve protrusion varies more than 0.005 in. (0.13 mm) around circumference, replace that sleeve and recheck.

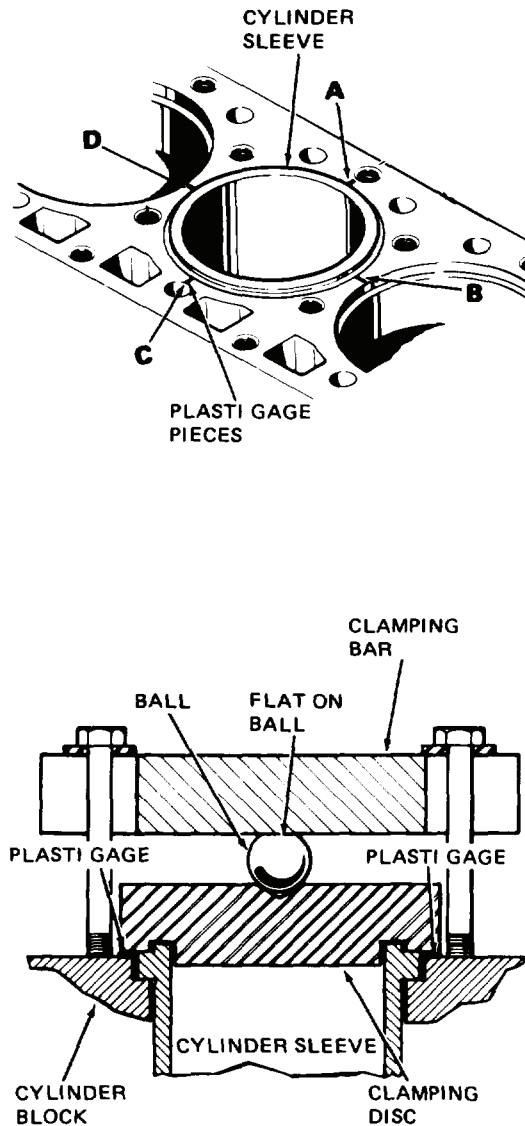

TA127254

**Figure 4. Installing Cylinder Sleeve.**

**END OF TASK**

**END OF WORK PACKAGE**

---

## GENERAL SUPPORT MAINTENANCE INSTRUCTIONS

### CYLINDER BLOCK REPAIR (MODEL 4-390)

#### Disassembly, Cleaning, Inspection, Assembly

---

#### INITIAL SETUP

##### Maintenance Level

General Support

##### Tools and Special Tools

Tool kit, general mechanic's (Item 15, WP 0309)  
 Shop equipment, common no. 1 (Item 2, WP 0309)  
 Ball  
 Bore gauge, 0 to 5 in.  
 Clamping bar  
 Clamping disc  
 Industrial goggles (NSN 4910-00-269-7912)  
 Micrometer, 0 to 5 in.  
 Sleeve, 3/4-in. diameter  
 Sleeve, 1-in. diameter  
 Sleeve, 3-3/16-in. diameter  
 Steel straightedge (P/N CAS-1369A)  
 Thickness gage (NSN 5210-00-221-1999)  
 Wire, 0.020-in. diameter  
 Wire probe, brass

##### Materials/Parts

Plastigage (Item 5, WP 0310)

##### Materials/Parts - Continued

Cleaning compound, solvent (Item 10, WP 0310)  
 Lubricating oil, OE/HDO-15/40 (Item 21, WP 0310)  
 Rag, wiping (Item 26, WP 0310)  
 Blue vitriol solution  
 Dry ice  
 Paint  
 O-ring (6)

##### Equipment Condition

Fuel pump removed (WP 0060)  
 Water pump removed (WP 0087)  
 Engine oil cooler removed (WP 0228)  
 Cylinder head removed (WP 0219)  
 Oil pan removed (WP 0227)  
 Timing gear cover removed (WP 0285)  
 Oil pump removed (WP 0287)  
 Flywheel and flywheel housing removed (WP 0279)  
 Crankshaft oil seal retainer removed (WP 0275)  
 Crankshaft and main bearings removed (WP 0277)  
 Pistons and connecting rod removed (WP 0281)  
 Camshaft and bearings removed (WP 0283)

---

DISASSEMBLY

NOTE

Remove cylinder sleeves only if inspection indicates removal/replacement is necessary.

1. Use paint to number and mark cylinder sleeve (Figure 1, Item 2) for position in relation to block if sleeves may be reinstalled.

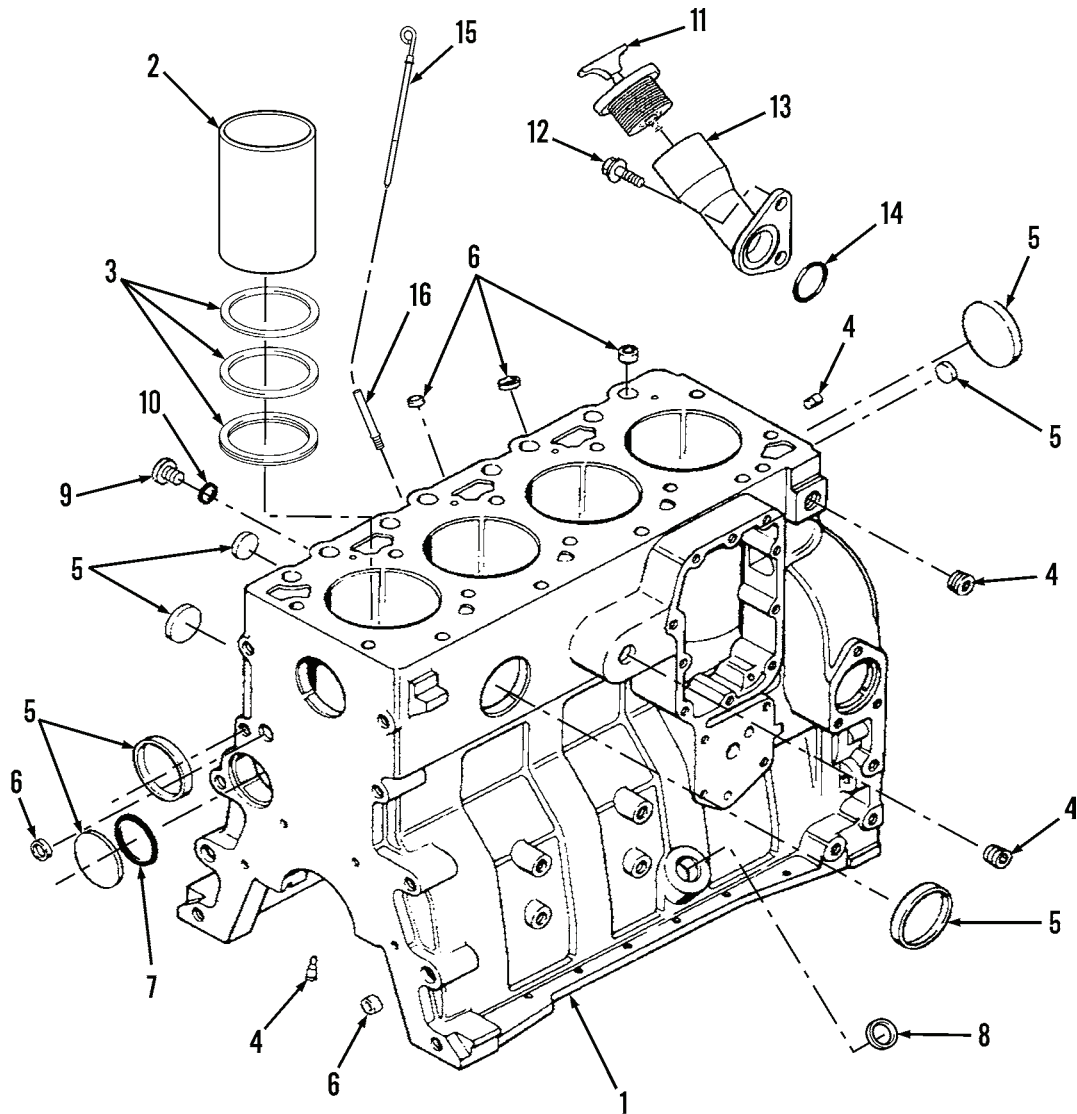

444-0320

Figure 1. Engine Cylinder Block.

**DISASSEMBLY - CONTINUED**

2. Use clamping bar to remove cylinder sleeve as shown (Figure 2).

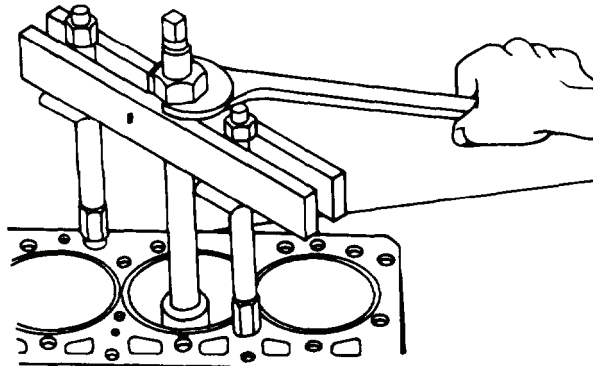

444-0357

**Figure 2. Removing Cylinder Sleeve.**

3. Remove three O-rings (Figure 1, Item 3) from cylinder block (Figure 1, Item 1) and discard.
4. Remove four plugs (Figure 1, Item 4) from cylinder block (Figure 1, Item 1).
5. Remove eight cap plugs (Figure 1, Item 5) from cylinder block (Figure 1, Item 1).
6. Remove four rings (Figure 1, Item 6) from cylinder block (Figure 1, Item 1).
7. Remove O-ring bearing (Figure 1, Item 8) and O-ring (Figure 1, Item 7) from cylinder block (Figure 1, Item 1). Discard O-ring.
8. Remove bolt (Figure 1, Item 9) and O-ring (Figure 1, Item 10) from cylinder block (Figure 1, Item 1). Discard O-ring.
9. Remove cap (Figure 1, Item 11), two bolts (Figure 1, Item 12), filler tube (Figure 1, Item 13), and O-ring (Figure 1, Item 14) from cylinder block (Figure 1, Item 1). Discard O-ring.
10. Remove dipstick and dipstick tube from cylinder block (Figure 1, Item 1).

**END OF TASK**

## CLEANING

1. Clean cylinder and crankcase oil passages thoroughly using moisture-free compressed air and brass wire probe. Clean exterior with live steam. Clean upper and lower cylinder grooves, oil galleries, and drain openings thoroughly. Clean camshaft bushing bores thoroughly. Use 0.020-in. (0.51-mm) diameter wire to clean camshaft bushing bore jets. Dry thoroughly with moisture-free compressed air.



**WARNING**

- Solvent cleaning compound MIL-PRF-680 Type III is an environmentally compliant and low toxic material. However, it may be irritating to the eyes and skin. Use protective gloves and goggles. Use in well-ventilated areas. Keep away from open flames and other sources of ignition. Failure to do so may result in injury or death to personnel.
  - Particles blown by compressed air are hazardous. DO NOT exceed 30 PSI (207 kPa) nozzle pressure when cleaning parts with compressed air. DO NOT exceed 15 PSI (103 kPa) nozzle pressure when drying parts with compressed air. DO NOT direct compressed air against human skin. Make sure air stream is directed away from user and other personnel in the area. To prevent injury, user must wear protective goggles or face shield. Failure to follow this warning may result in injury to personnel.
2. Use solvent cleaning compound to clean cylinder sleeves. Dry thoroughly with moisture-free compressed air or clean rags.
  3. Clean all other parts. Immerse in solvent cleaning compound. Dry thoroughly with moisture-free compressed air or clean rags.

## END OF TASK

## INSPECTION

1. Inspect cylinder block (Figure 3, Item 1). Replace if cracked, damaged, worn, eroded, or distorted or if grooves and lands pitted or eroded.
2. Use straightedge and feeler gage to measure top surface of cylinder block (Figure 3, Item 1). If surface varies more than 0.002 in. (0.05 mm), replace block.
3. Check taper and out-of-roundness of cylinder sleeve bores with bore gauge. If taper or out-of-roundness exceeds 0.002 in. (0.05 mm), replace block.
4. Inspect cylinder sleeve (Figure 3, Item 2). Replace if smooth, shiny surface along complete length or heavy vertical lines fringed by metal transferring from one spot to another are observed.



**WARNING**

Blue vitriol solution contains acid. Wear safety goggles to protect eyes from accidental splashing and avoid splashing solution on skin. If solution is splashed on you skin or in your eyes, wash off immediately with water and get medical aid. Failure to do so may result in injury to personnel.



## INSPECTION - CONTINUED

## NOTE

If blue vitriol solution cannot be obtained from druggist, a satisfactory solution can be made from copper sulfate crystals available at hobby stores or pharmacies. To prepare solution: add 1 tablespoon fresh battery acid to 1 cup water; add 1/2 level teaspoon copper sulfate crystals to solution; stir with plastic spoon until crystals are dissolved.

5. Check chrome plating. Wet inside of sleeve with cotton swab saturated with blue vitriol solution. If bright copper color is observed, replace sleeve. Rinse tested surfaces with water after check.
6. Check sleeve inside diameter for taper. Use inside micrometer or bore gage. Check below top ring location and at several points down length. Replace if taper is more than 0.002 in. (0.05 mm).
7. Check sleeve out-of-roundness. Use bore gage. Measure lengthwise just below top ring location at four points 90 degrees from each other. Replace if out-of-roundness exceeds 0.001 in. (0.03 mm) (use micrometer to check bore gage).
8. Inspect dipstick and dipstick tube. Replace if bent, cracked, or dented.
9. Inspect four rings (Figure 3, Item 6). Replace if deformed or nicked.
10. Inspect all other parts. Replace if threads are damaged.

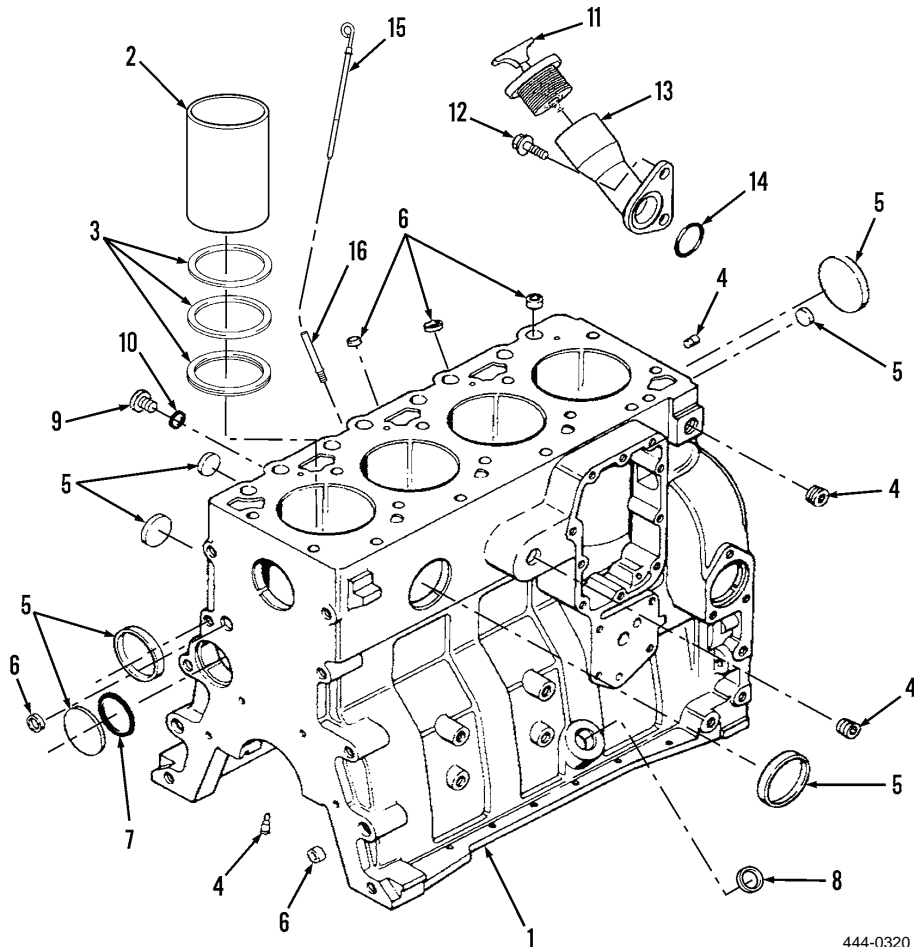

444-0320

Figure 3. Engine Cylinder Block.

END OF TASK

**ASSEMBLY****WARNING**

Dry ice is extremely cold and will immediately freeze skin. Use heavy gloves when handling dry ice and avoid any contact with unprotected skin. If injured, obtain medical aid immediately.

1. Chill filler tube (Figure 4, Item 13) and dipstick in dry ice and install smooth end in cylinder block (Figure 4, Item 1) until firmly seated.
2. Install new O-ring (Figure 4, Item 14), filler tube (Figure 4, Item 13), two bolts (Figure 4, Item 12), and cap (Figure 4, Item 11) on cylinder block (Figure 4, Item 1).
3. Install new O-ring (Figure 4, Item 10) and bolt (Figure 4, Item 9) in rear of cylinder block (Figure 4, Item 1) until flush with front of block.
4. Install bearing (Figure 4, Item 8) on cylinder block (Figure 4, Item 1).
5. Install new O-ring (Figure 4, Item 7) in rear of cylinder block (Figure 4, Item 1) until flush with front of block.
6. Install eight cap plugs (Figure 4, Item 5) on cylinder block (Figure 4, Item 1).
7. Install four plugs (Figure 4, Item 4) on cylinder block (Figure 4, Item 1).
8. Use clean engine oil to lubricate three new O-rings (Figure 4, Item 3) and install in cylinder sleeve bottom grooves.
9. Clean upper and lower grooves of cylinder sleeve bore.

**NOTE**

If old sleeves are being reinstalled, install in same location and position as they were prior to removal.

10. Chill cylinder sleeve (Figure 4, Item 2) in dry ice and install with hand pressure. Do not rotate sleeve during installation and be careful not to damage O-rings. Cylinder sleeves must be even with top surface of cylinder block.

ASSEMBLY - CONTINUED

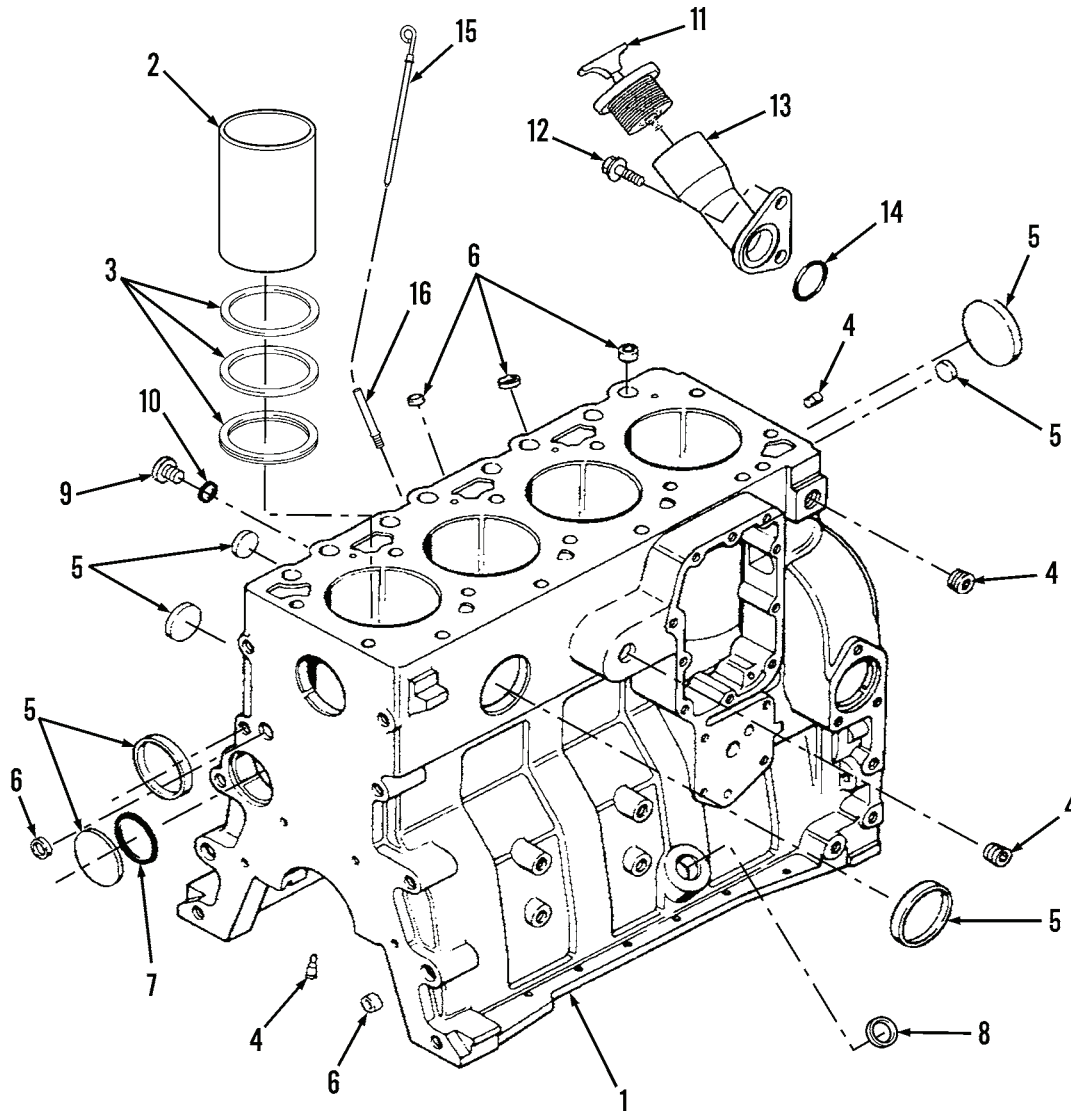

444-0320

Figure 4. Engine Cylinder Block.

END OF TASK

END OF WORK PACKAGE



---

## GENERAL SUPPORT MAINTENANCE INSTRUCTIONS

### CYLINDER HEAD AND VALVES REPAIR (MODEL 207)

Removal, Cleaning, Inspection/Repair, Installation

---

#### INITIAL SETUP

##### Maintenance Level

General Support

##### Tools and Special Tools

Tool kit, general mechanic's (Item 15, WP 0309)  
Shop equipment, common no. 1 (Item 2, WP 0309)  
Expandable bore gage, 0 to 1/2 in.  
Feeler gage (NSN 5210-00-221-1999)  
Fine rotary wire brush  
Grinding stone, 30-degree  
Grinding stone, 45-degree  
Grinding stone, 60-degree  
Precision seat grinder  
Power-driven fine wire brush  
Reamer (P/N A43112)  
Spring tester  
Valve refacing machine

##### Tools and Special Tools - Continued

Valve seat removal tool  
Valve spring compressor tool  
Vee block holder

##### Materials/Parts

Cleaning compound, solvent (Item 10, WP 0310)  
Lubricating oil, OE/HDO-15/40 (Item 21, WP 0310)  
Prussian blue (Item 25, WP 0310)  
Rag, wiping (Item 26, WP 0310)  
Dry ice  
Emery cloth, medium grit  
Valve keepers (2)

##### Equipment Condition

Rocker arm assembly removed (WP 0231)  
Cylinder head assembly removed (WP 0225)

---

**REMOVAL**

1. Use valve spring compressor tool to compress valve spring (Figure 1, Item 3).
2. Remove two valve keepers (Figure 1, Item 1) from cylinder head (Figure 1, Item 8). Discard valve keepers.
3. Carefully release pressure on valve spring (Figure 1, Item 3).
4. Remove spring retainer (Figure 1, Item 2) from cylinder head (Figure 1, Item 8).
5. Remove valve spring (Figure 1, Item 3) from cylinder head (Figure 1, Item 8).
6. Remove spring seat (Figure 1, Item 4) from cylinder head (Figure 1, Item 8).
7. Remove valve stem seal (Figure 1, Item 5) from cylinder head (Figure 1, Item 8).

**NOTE**

Identify (number) valves (Figure 1, Items 6 and 7) and respective bores for reference during installation.

8. Remove exhaust valve (Figure 1, Item 6) from bottom of cylinder head (Figure 1, Item 8).
9. Remove intake valve (Figure 1, Item 7) from bottom of cylinder head (Figure 1, Item 8).

**END OF TASK****CLEANING****CAUTION**

In step 1, be careful not to scratch valve stems.

1. Use fine power-driven wire brush to clean four exhaust valves (Figure 1, Item 6) and intake valves (Figure 1, Item 7).

**WARNING**

- Solvent cleaning compound MIL-PRF-680 Type III is an environmentally compliant and low toxic material. However, it may be irritating to the eyes and skin. Use protective gloves and goggles. Use in well-ventilated areas. Keep away from open flames and other sources of ignition. Failure to do so may result in injury or death to personnel.
  - Particles blown by compressed air are hazardous. DO NOT exceed 15 PSI (103 kPa) nozzle pressure when drying parts with compressed air. DO NOT direct compressed air against human skin. Make sure air stream is directed away from user and other personnel in the area. To prevent injury, user must wear protective goggles or face shield. Failure to follow this warning may result in injury to personnel.
2. Use solvent cleaning compound to clean cylinder head (Figure 1, Item 8). Dry with moisture-free compressed air or clean rag.
  3. Use fine rotary wire brush to clean valve ports.
  4. Clean machined surface areas. Use medium-grit emery cloth carefully to remove all gasket material, carbon, and rust.
  5. Use solvent cleaning compound to clean all other parts. Dry with moisture-free compressed air or clean rag.

CLEANING - CONTINUED

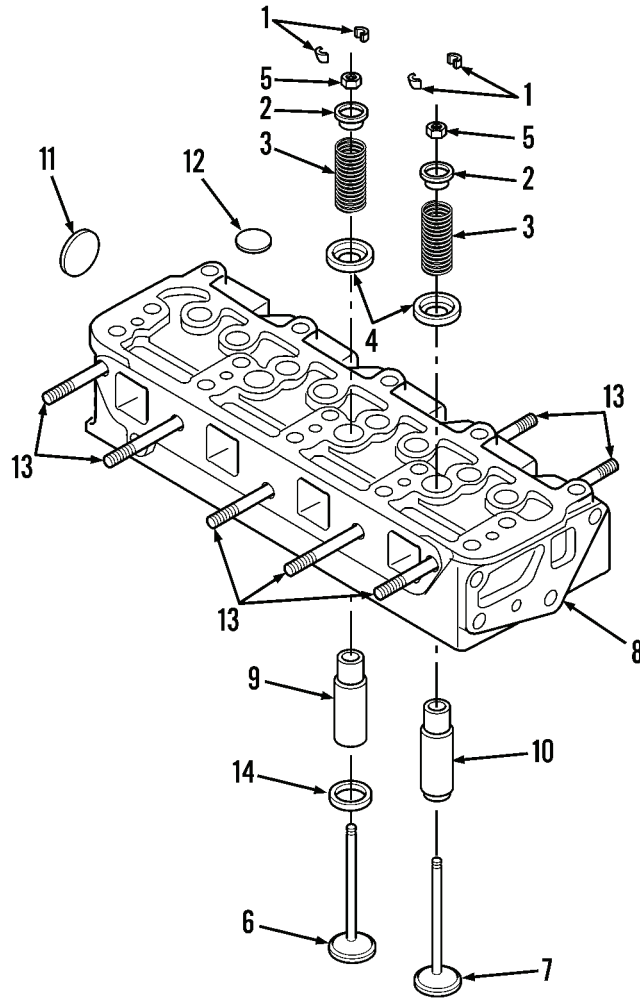

444-1303

Figure 1. Cylinder Head and Valves.

END OF TASK

**INSPECTION/REPAIR**

1. Inspect valve spring (Figure 1, Item 3). Install in spring tester. Ensure force to compress spring to 1.521 in. (38.63 mm) is 110 to 118 lb (50 to 54 kg) and force to compress spring to 1.875 in. (48 mm) is 53 to 59 lb (24 to 27 kg). Replace spring if force is less than these values.

**NOTE**

If cylinder head is resurfaced, maintain a minimum thickness of 3.968 in. (100.79 mm).

2. Lay straightedge diagonally from corner to corner on bottom surface of cylinder head and try to insert a 0.006 in. (0.15 mm) feeler gage under straightedge. Check for warpage at several points. Reposition straightedge at opposite corners and repeat checks. If warpage is greater than 0.006 in. (0.15 mm), resurface or replace cylinder head.
3. Use bore gage and check inside diameter of valve guides (Figure 1, Items 9 and 10) in three places as shown (Figure 13). Measure bore gage with micrometer. If greater than 0.3449 in. (8.760 mm) at any point, replace valve guides.

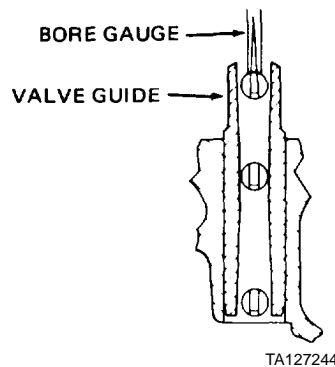

**Figure 2. Measuring Valve Guide.**

**NOTE**

If valve guides (Figure 3, Items 9 and 10) require replacement, perform steps 4 through 6; otherwise, proceed to step 7.

4. Use hydraulic press and press guides from top, through cylinder head and remove valves guides (Figure 3, Items 9 and 10).
5. Install valves guides (Figure 3, Items 9 and 10) on top of cylinder head. Use hydraulic press and push into head until valve guide protrudes 0.875 in. (22.23 mm) above top of head.
6. Ream valve guides (Figure 3, Items 9 and 10). Use reamer (P/N A43112). Ream to 0.3429 to 0.3439 in. (8.710 to 8.735 mm).
7. Inspect plugs (Figure 3, Items 11 and 12) and check for damage and looseness. If plugs are damaged or loose, replace.
8. Drill and pry out plugs (Figure 3, Items 11 and 12).
9. Install and seat new plug (Figure 3, Item 11), then strike with hammer to expand.
10. Install new plug (Figure 3, Item 12) to 0.370 in. (9.40 mm) depth.
11. Inspect studs (Figure 3, Item 13) for bent condition and damaged threads. If bent or threads damaged, replace. Replace by unscrewing stud and screwing new stud into cylinder head.
12. Inspect exhaust valve (Figure 3, Item 6) and intake valve (Figure 3, Item 7). Replace if valve stem is nicked, valve face grooved, heavy carbon and/or varnished deposits, rust or pitting on valve stem or valve face, burned valve face, or dished valve head. Fine pitting on surface of valve face or seat is normal.
13. Inspect retainer groove. Replace if worn or if stem tip is worn.



INSPECTION/REPAIR - CONTINUED

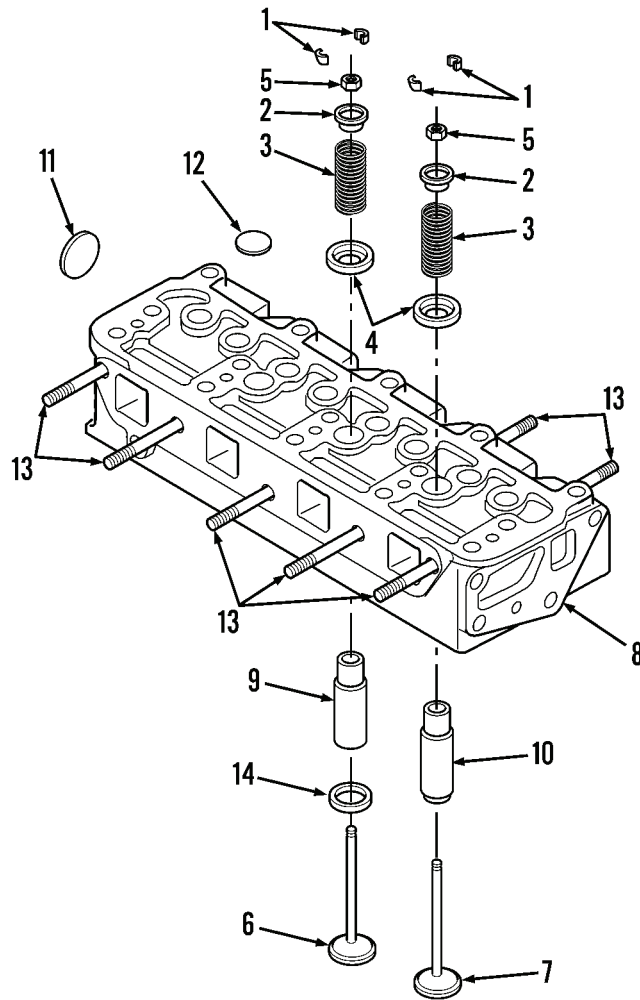

444-1303

Figure 3. Cylinder Head and Valves.

**INSPECTION/REPAIR - CONTINUED**

14. Measure valve stem diameter in three places as shown (Figure 4). Replace exhaust valve (Figure 6, Item 6) if less than 0.3389 in. (8.608 mm). Replace intake valve (Figure 6, Item 7) if less than 0.3399 in. (8.633 mm).

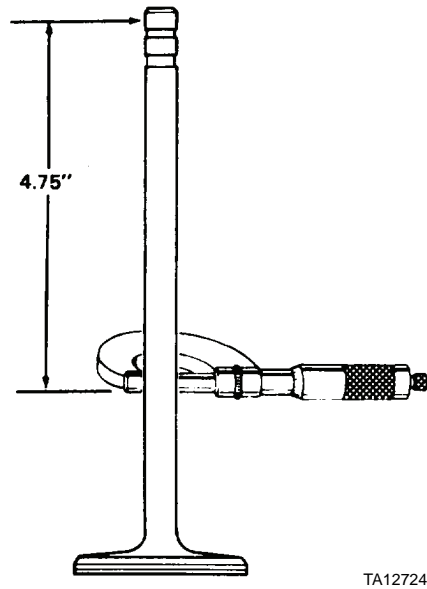

TA127245

**Figure 4. Measuring Valve Stem.**

15. Measure valve face and stem runout. Check as shown (Figure 5). If runout exceeds 0.002 in. (0.05 mm), replace valve.

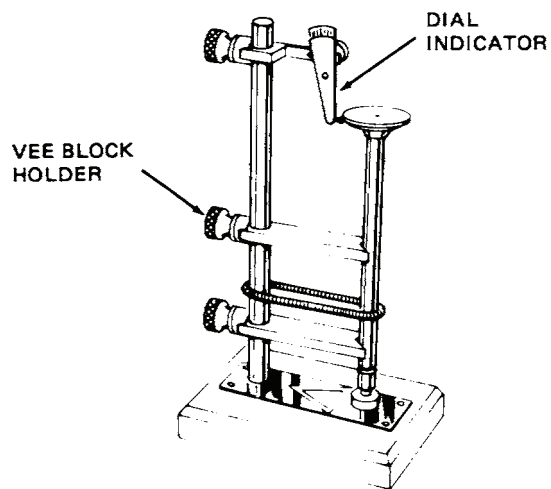

TA127246

**Figure 5. Measuring Valve Face and Stem Runout.**

INSPECTION/REPAIR - CONTINUED

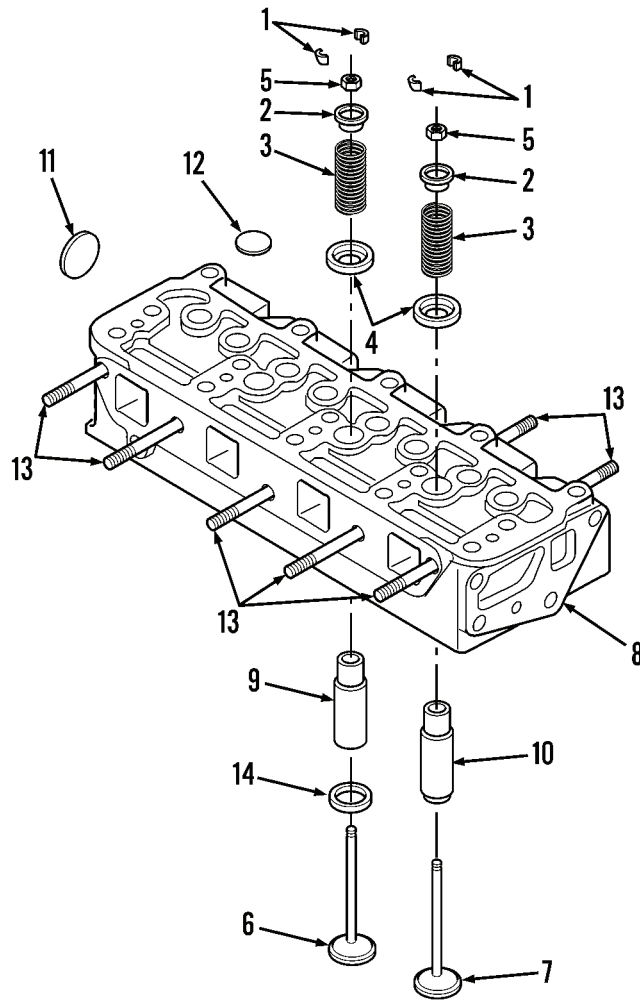

444-1303

Figure 6. Cylinder Head and Valves.

**INSPECTION/REPAIR - CONTINUED**

16. Install intake valve (Figure 9, Item 7) and exhaust valve (Figure 9, Item 6) and check valve recession as shown (Figure 7). If exhaust valve recession is more than 0.005 in. (0.13 mm), replace valve or valve seat insert. If intake valve recession is more than 0.005 in. (0.13 mm), replace intake valve and recheck recession. If recession is still more than 0.005 in. (0.13 mm), replace or resurface cylinder head (minimum cylinder head thickness of 3.968 in. [100.79 mm] must be maintained).

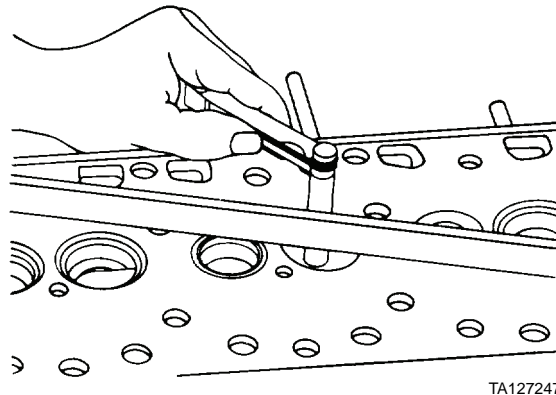

**Figure 7. Measuring Valve Recession.**

**CAUTION**

Do not remove valve seat inserts with punch, chisel, or pry bar as damage to cylinder head will result.

**NOTE**

If valve seat inserts require replacement, perform steps 17 and 18; otherwise, proceed to step 19.

17. Remove valve seat insert (Figure 9, Item 14) from cylinder head (Figure 9, Item 8).
18. Clean valve seat insert recesses in cylinder head. Place new inserts in dry ice to shrink them, then install by pressing into cylinder block until bottomed in recess.
19. Install intake valve (Figure 9, Item 7) and exhaust valve (Figure 9, Item 6) and check valve protrusion as shown (Figure 8). If protrusion is more than 0.005 in. (0.13 mm), valve and seat must be ground (steps 20 through 23).

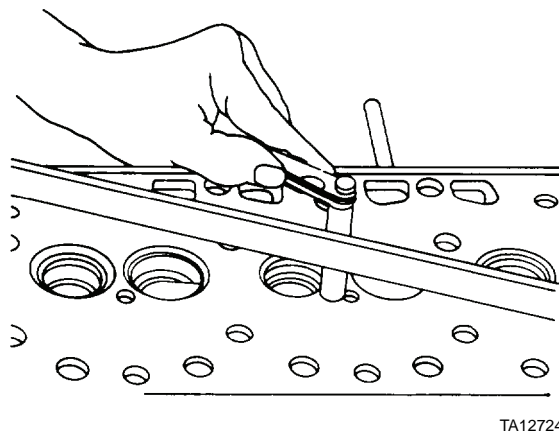

**Figure 8. Measuring Valve Protrusion.**

INSPECTION/REPAIR - CONTINUED

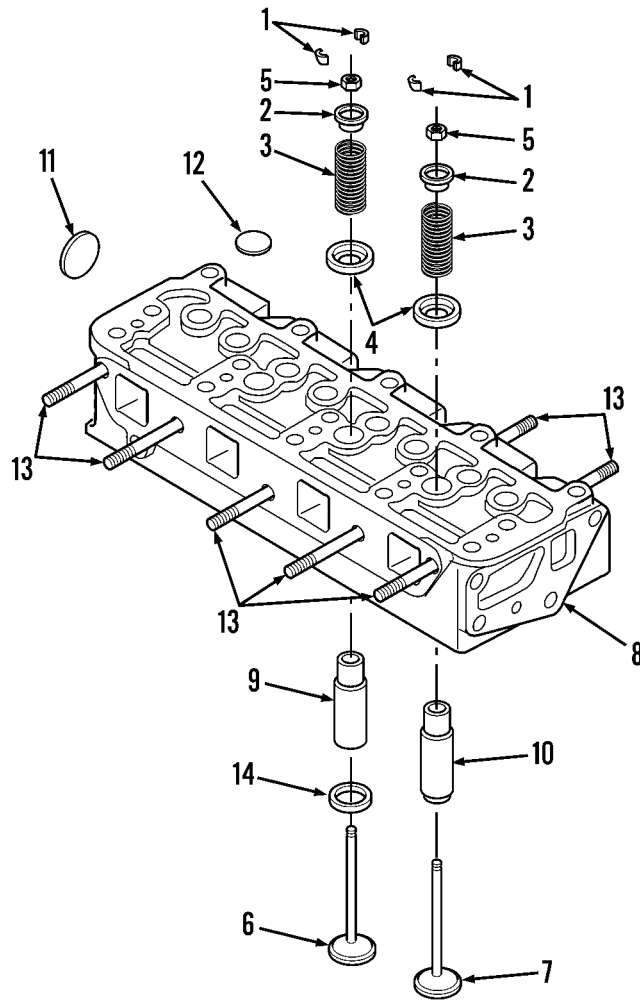

444-1303

Figure 9. Cylinder Head and Valves.

**INSPECTION/REPAIR - CONTINUED**

20. To reface machine, set protractor at 44 degree angle.
21. Clean chuck and dress grinding wheel.
22. Grind valves lightly at an angle of 44 degrees.

**NOTE**

Replace any valve that has a thin margin or edge. If margin on ground valve is less than half margin on new valve, replace that valve.

23. Grind valve seats and insert lightly as shown (Figure 10). Use precision seat grinder. Take very light cuts to remove just enough metal to obtain a smooth seat finish.

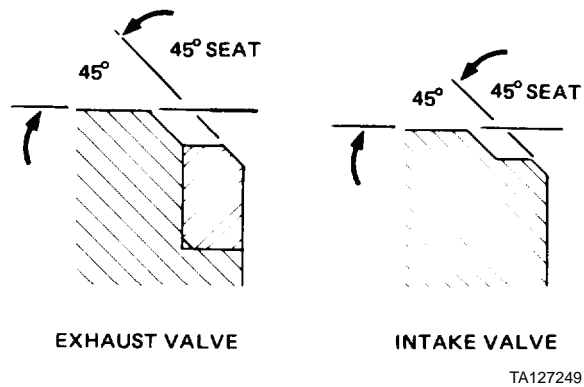

**Figure 10. Grinding Valve Seats.**

**INSPECTION/REPAIR - CONTINUED**

24. Apply Prussian Blue to valve face and install valves in cylinder head. Rotate valve in seat.
25. Check contact area on valve face and seat. Bluing will be removed from valve face where contact was made with seat. Correct and incorrect indications along with remedial procedures are shown in Figure 11 and Figure 12.

**NOTE**

After valves and valve seats are ground, valve recession and protrusion must be rechecked (steps 16 and 19, respectively, of *Inspection/Repair* in this work package).

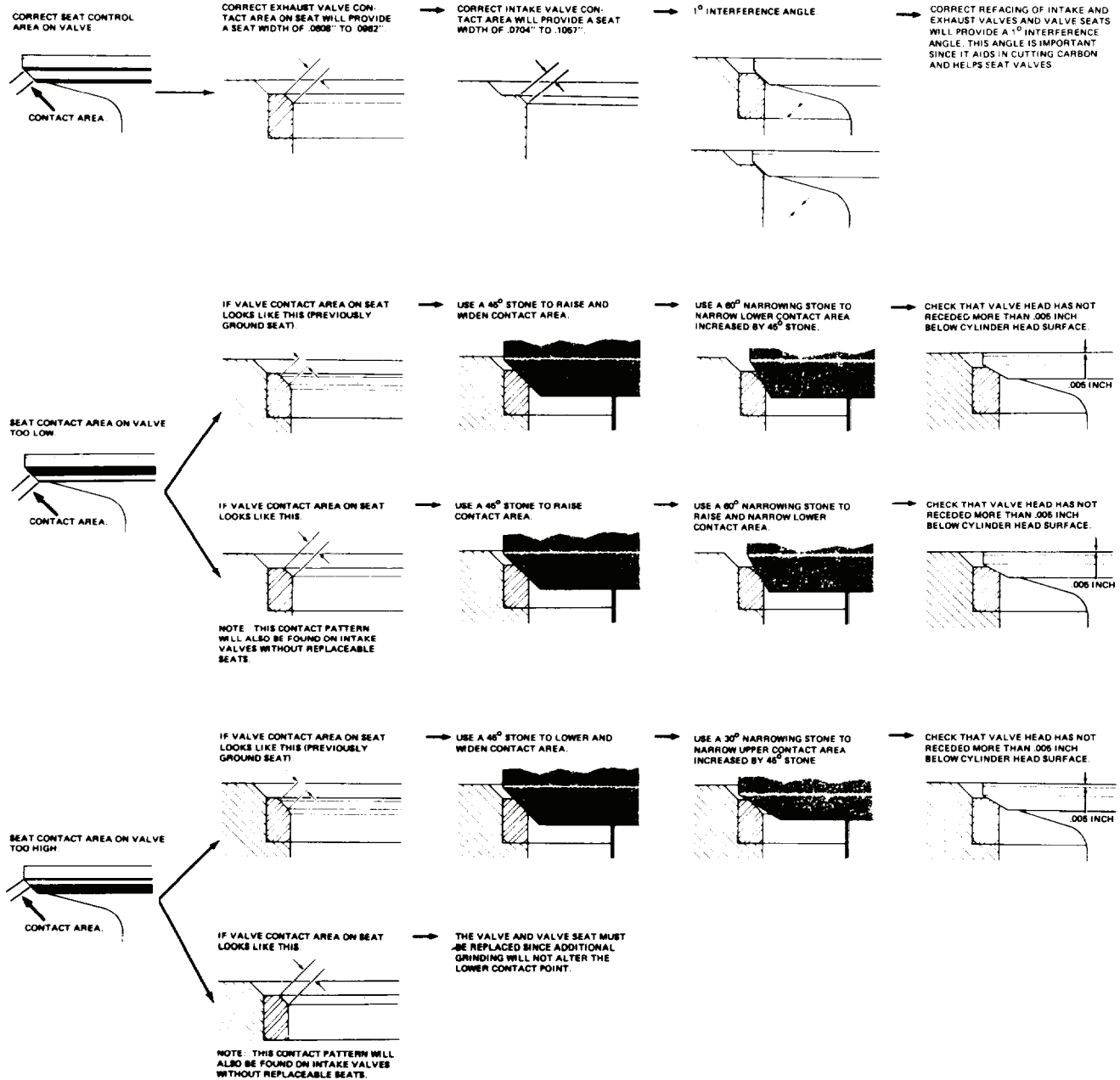

TA127250

Figure 11. Valve Seat Refacing.

INSPECTION/REPAIR - CONTINUED

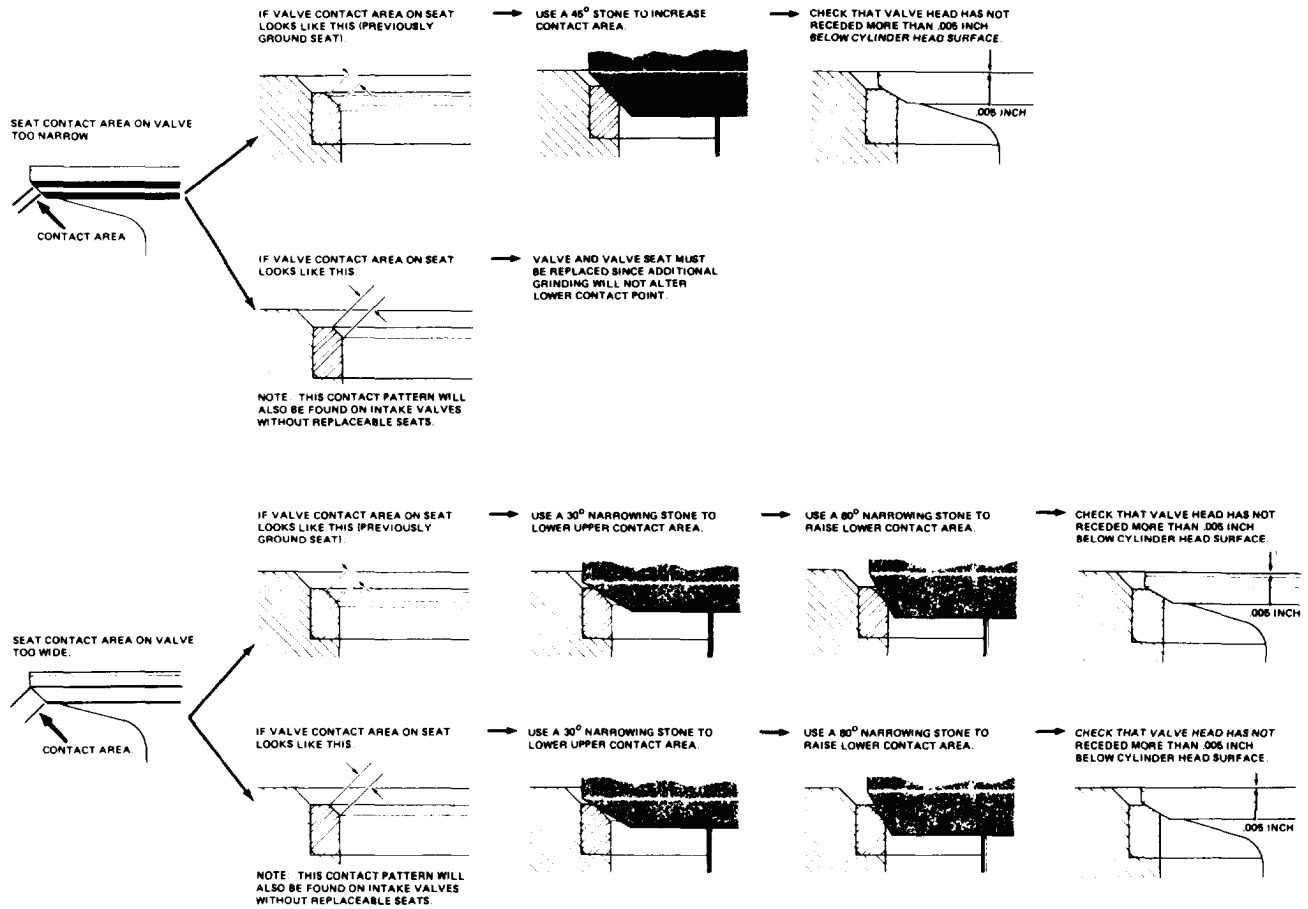

TA127251

Figure 12. Valve Seating Refacing.

END OF TASK



**INSTALLATION**

1. Use clean engine oil to lubricate valve stems and install valves (Figure 13, Items 6 and 7) in proper bores.
2. Install spring seat (Figure 13, Item 4) on cylinder head (Figure 13, Item 8).
3. Install valve spring (Figure 13, Item 3) on cylinder head (Figure 13, Item 8) with closed damping coil end towards cylinder head.
4. Install spring retainer (Figure 13, Item 2) on cylinder head (Figure 13, Item 8).
5. Install valve stem seal (Figure 13, Item 5) on cylinder head (Figure 13, Item 8).
6. Use valve spring compressor tool and compress spring. Install spring in lower stem groove.
7. Install two valve keepers (Figure 13, Item 1) on top valve stem groove. Remove valve spring compressor tool carefully and tap valve stem to seat valve keepers.

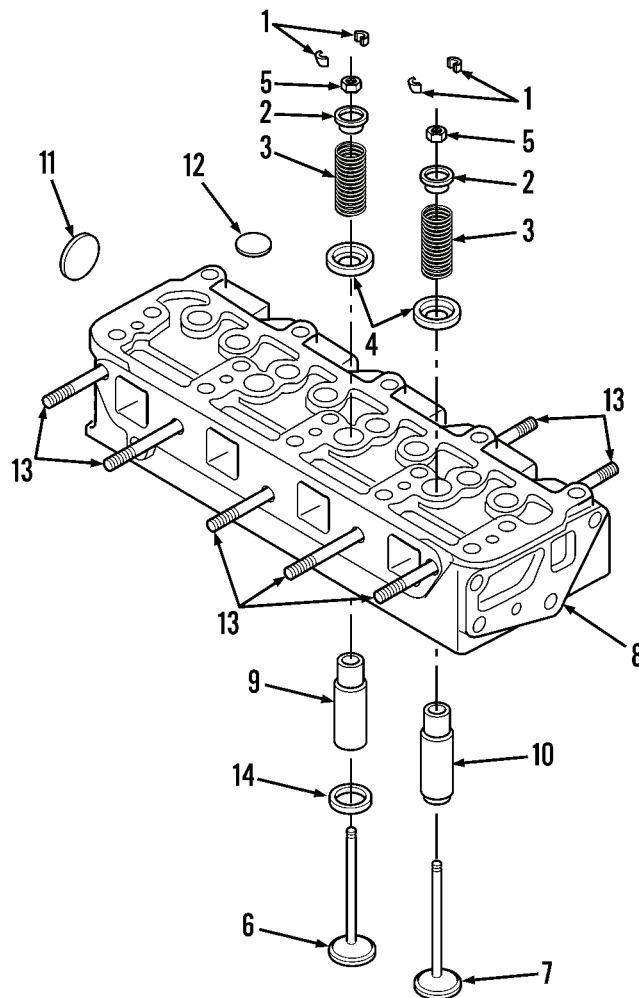

444-1303

**Figure 13. Cylinder Head and Valves.****END OF TASK****END OF WORK PACKAGE**



---

## GENERAL SUPPORT MAINTENANCE INSTRUCTIONS

### CYLINDER HEAD AND VALVES REPAIR (MODEL 4-390)

Removal, Cleaning, Inspection/Repair, Valves and Valve Seat Refacing, Installation

---

#### INITIAL SETUP

##### Maintenance Level

General Support

##### Tools and Special Tools

Tool kit, general mechanic's (Item 15, WP 0309)  
Shop equipment, common no. 1 (Item 2, WP 0309)  
Expandable bore gage, 0 to 1/2 in.  
Feeler gage  
Fine power-driven wire brush  
Fine rotary wire brush  
Grinding stone, 45-degree  
Grinding stone, 60-degree  
Grinding stone, 30-degree  
Micrometer, 0 to 5 in.  
Precision seat grinder  
Reamer (P/N A43112)  
Spring tester

##### Tools and Special Tools - Continued

Steel straightedge (P/N CAS-1369A)  
Valve refacing machine  
Valve seat removal tool  
Valve spring compressor tool  
Vee block holder

##### Materials/Parts

Cleaning compound, solvent (Item 10, WP 0310)  
Lubricating oil, OE/HDO-15/40 (Item 21, WP 0310)  
Prussian blue (Item 25, WP 0310)  
Rag, wiping (Item 26, WP 0310)  
Dry ice  
Valve keeper (2)

##### Equipment Condition

Rocker arm assembly removed (WP 0225)  
Cylinder head assembly removed (WP 0219)

---

**REMOVAL**

1. Use valve spring compressor tool to compress valve spring (Figure 1, Item 2).
2. Remove and discard two valve keepers (Figure 1, Item 3) from spring retainer (Figure 1, Item 4).
3. Release valve spring (Figure 1, Item 2) by carefully releasing pressure on valve spring compressor tool.
4. Remove spring retainer (Figure 1, Item 4) from valve spring (Figure 1, Item 2).
5. Remove valve spring (Figure 1, Item 2) from valve stem seal (Figure 1, Item 5).
6. Remove valve stem seal (Figure 1, Item 5) from cylinder head (Figure 1, Item 1).

**NOTE**

Identify (number) valves and respective bores for reference during installation.

7. Remove exhaust valve (Figure 1, Item 6) from bottom of cylinder head (Figure 1, Item 1).
8. Remove intake valve (Figure 1, Item 7) from bottom of cylinder head (Figure 1, Item 1).

**CLEANING****CAUTION**

In step 1, be careful not to scratch valve stems.

1. Use fine power-driven wire brush to clean four exhaust valves (Figure 1, Item 6) and intake valves (Figure 1, Item 7).

**WARNING**

- Solvent cleaning compound MIL-PRF-680 Type III is an environmentally compliant and low toxic material. However, it may be irritating to the eyes and skin. Use protective gloves and goggles. Use in well-ventilated areas. Keep away from open flames and other sources of ignition. Failure to do so may result in injury or death to personnel.
  - Particles blown by compressed air are hazardous. DO NOT exceed 15 PSI (103 kPa) nozzle pressure when drying parts with compressed air. DO NOT direct compressed air against human skin. Make sure air stream is directed away from user and other personnel in the area. To prevent injury, user must wear protective goggles or face shield. Failure to follow this warning may result in injury to personnel.
2. Use solvent cleaning compound to clean cylinder head (Figure 1, Item 1). Dry with moisture-free compressed air or clean rags.
  3. Use fine rotary wire brush to clean valve ports.
  4. Clean machined surface areas. Use medium-grit emery cloth to carefully remove all gasket material, carbon, and rust.
  5. Use solvent cleaning compound to clean all other parts. Dry with moisture-free compressed air.

CLEANING - CONTINUED

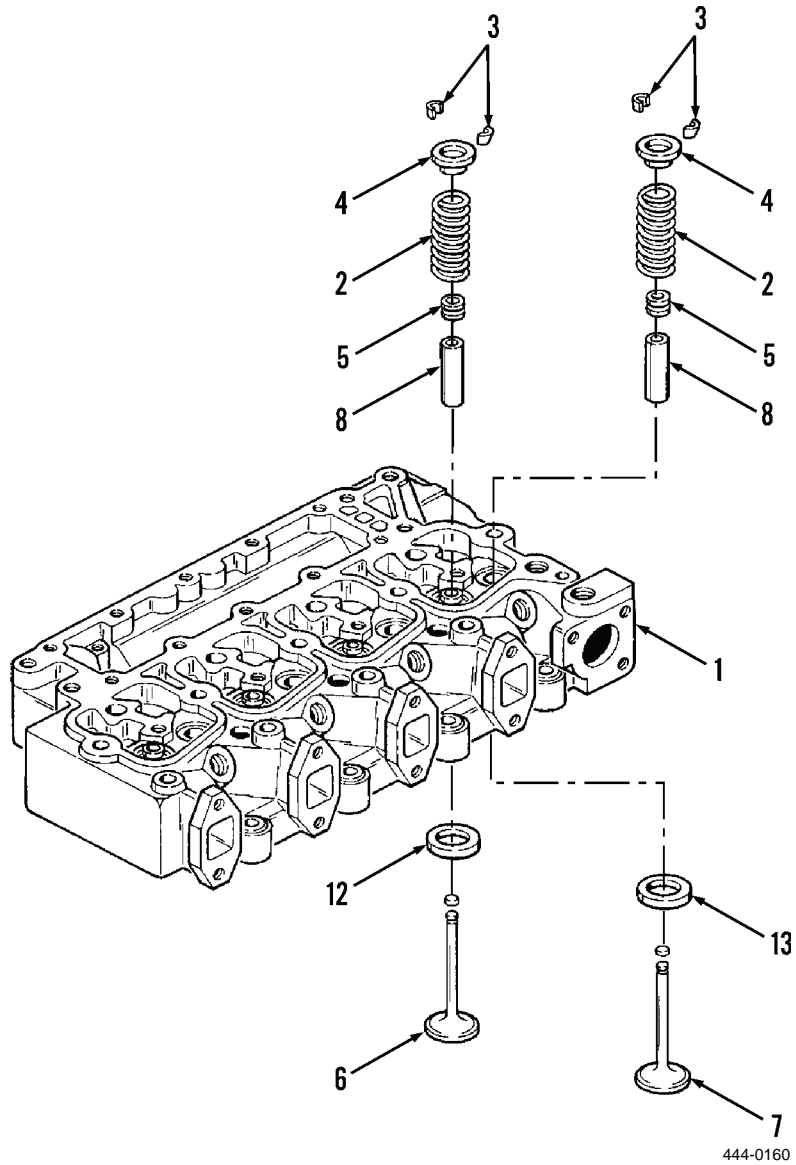

Figure 1. Cylinder Head and Valves.

END OF TASK

**INSPECTION/REPAIR**

1. Install spring tester on valve spring (Figure 3, Item 2). Ensure force to compress spring to 1.521 in. (39 mm) is 110 to 118 lb (50 to 54 kg) and force to compress spring to 1.875 in. (48 mm) is 53 to 59 lb (24 to 28 kg). Replace spring if force is less than these values.

**NOTE**

If cylinder head is resurfaced, maintain a minimum thickness of 3.968 in. (100.79 mm).

2. Check warpage of bottom surface of cylinder head (Figure 3, Item 1). Lay straightedge diagonally from corner to corner and try to insert a 0.006 in. (0.15 mm) feeler gage under straightedge. Check at several points. Reposition straightedge at opposite corners and repeat checks. If warpage is greater than 0.006 in. (0.15 mm), resurface or replace cylinder head.
3. Check inside diameter of valve guides (Figure 3, Item 8). Use bore gage and check in three places as shown (Figure 2). Measure bore gage with micrometer. If greater than 0.3449 in. (8.760 mm) at any point, replace valve guides.

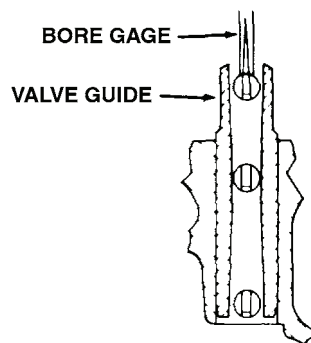

444-0360

**Figure 2. Measuring Valve Guides.****NOTE**

If valve guides require replacement, perform steps 4 through 6; otherwise, proceed to step 7.

4. Remove valve guides (Figure 3, Item 8). Use hydraulic press and press guides from top, through cylinder head.
5. Position and install valve guides (Figure 3, Item 8) on top of cylinder head. Use hydraulic press and push into head until valve guide protrudes 0.875 in. (22.23 mm) above top of head.
6. Ream valve guides (Figure 3, Item 8). Use P/N A43112 reamer. Ream to 0.3429 to 0.3439 in. (8.710 to 8.735 mm).

INSPECTION/REPAIR - CONTINUED

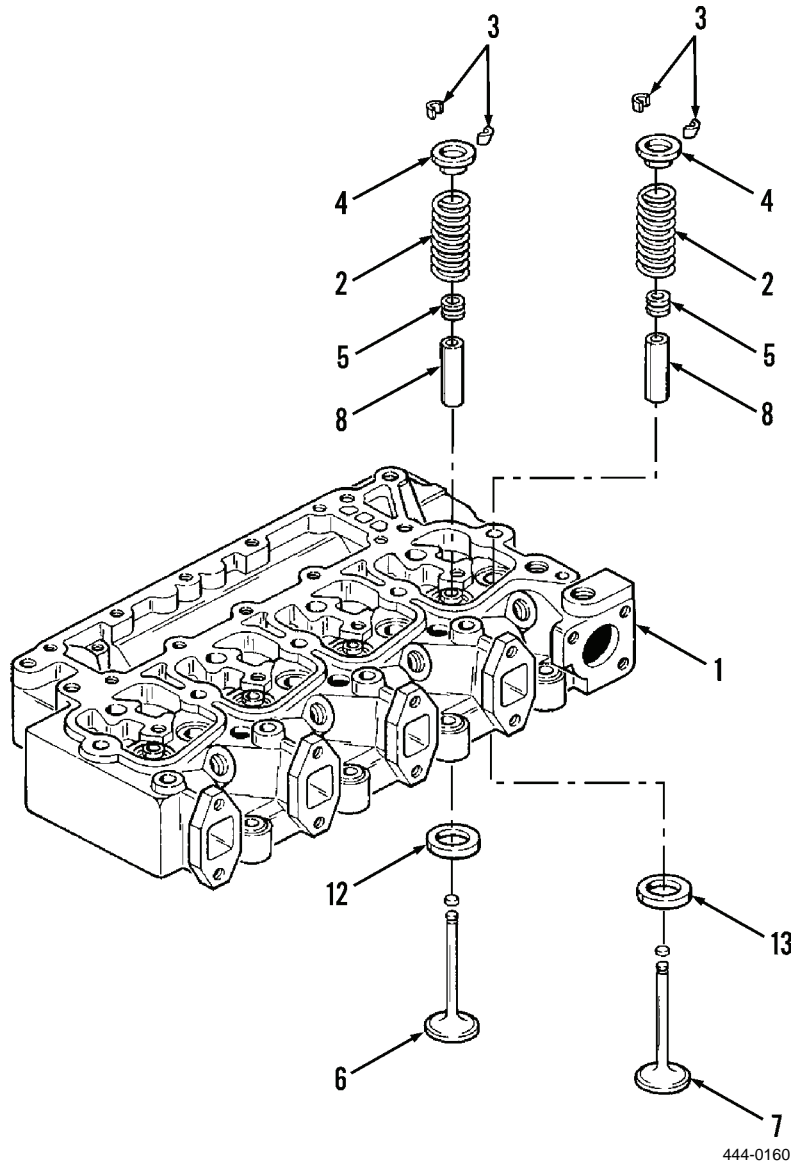
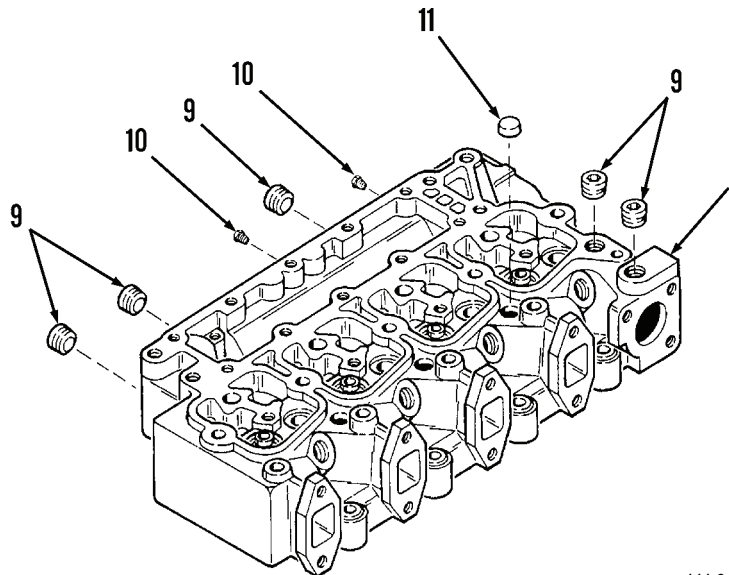

Figure 3. Cylinder Head and Valves.

**INSPECTION/REPAIR - CONTINUED**

7. Inspect plugs (Figure 4, Items 9, 10, and 11). Check for damage and looseness. If plugs are damaged or loose, replace.



444-0161

**Figure 4. Cylinder Head.**

8. Inspect exhaust valve (Figure 6, Item 6) and intake valve (Figure 6, Item 7). Replace if valve stem is nicked, valve face grooved, heavy carbon and/or varnish deposits, rust or pitting on valve stem or valve face, burned valve face, or dished valve head. Fine pitting on surface of valve face or seat is normal.
9. Inspect retainer groove. Replace if worn or if stem tip is worn.
10. Measure stem diameter in three places as shown (Figure 5). Replace exhaust valve (Figure 6, Item 6) if less than 0.3389 in. (8.608 mm). Replace intake valve (Figure 6, Item 7) if less than 0.3399 in. (8.633 mm).

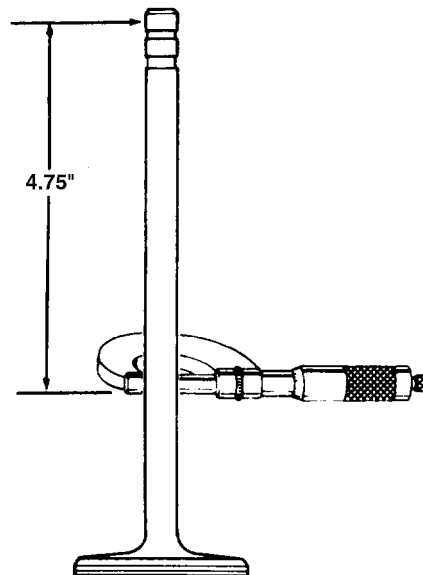

444-0361

**Figure 5. Measuring Valve Stem.**



INSPECTION/REPAIR - CONTINUED

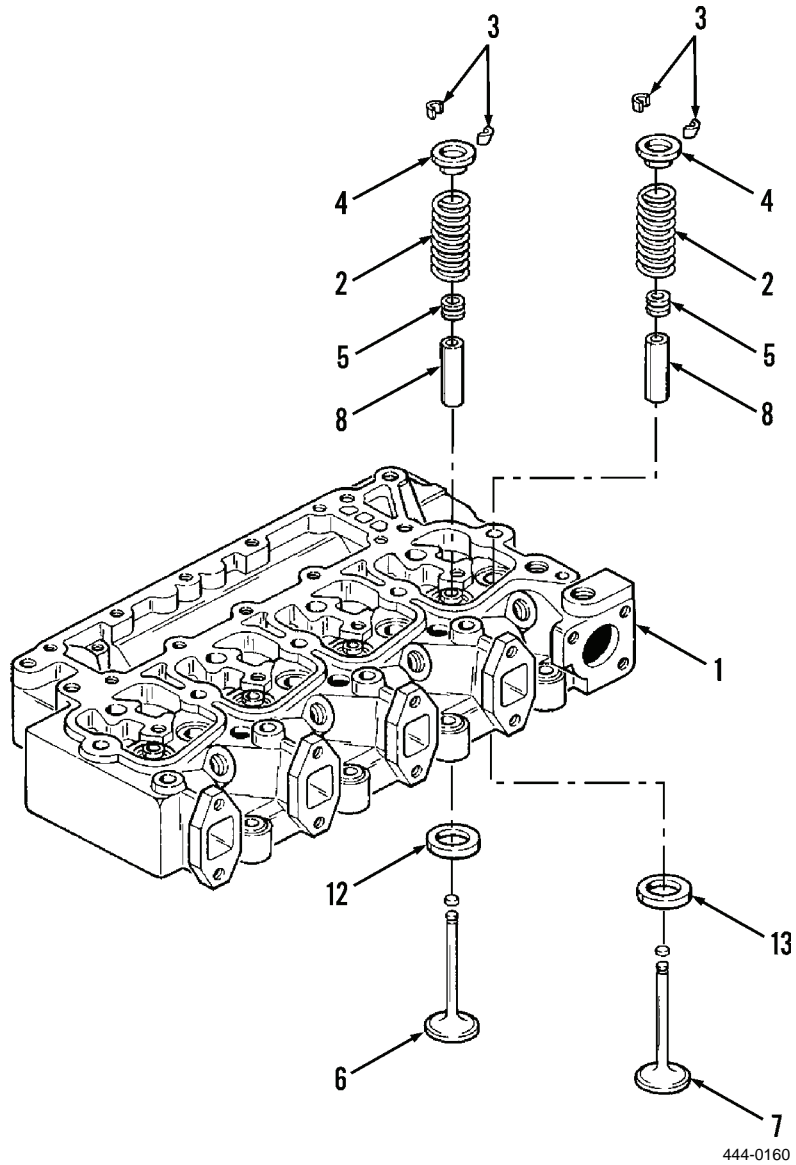
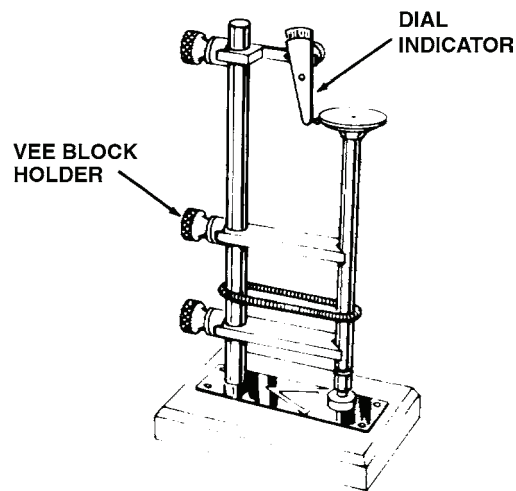

Figure 6. Cylinder Head and Valves.

444-0160

**INSPECTION/REPAIR - CONTINUED**

11. Measure valve face and stem runout as shown (Figure 7). If runout exceeds 0.002 in. (0.05 mm), replace valve.



444-0362

**Figure 7. Measuring Valve Face and Stem Runout.**

12. Install intake valve (Figure 9, Item 7) and exhaust valve (Figure 9, Item 6) and check valve recession as shown (Figure 8). If exhaust valve recession is more than 0.005 in. (0.13 mm), replace exhaust valve or valve seat insert (Figure 9, Item 12). If intake valve recession is more than 0.005 in. (0.13 mm), replace intake valve or valve seat insert (Figure 9, Item 13) and recheck recession. If recession is still more than 0.005 in. (0.13 mm), replace or resurface cylinder head (minimum cylinder head thickness of 3.968 in. [100.79 mm] must be maintained).

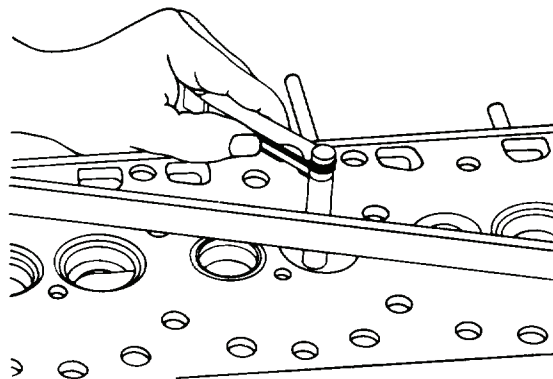

444-0363

**Figure 8. Measuring Valve Recession.**

**CAUTION**

Do not remove valve seat inserts with punch, chisel, or pry bar as damage to cylinder head will result.

**NOTE**

If valve seat inserts require replacement perform steps 13 and 14; otherwise, proceed to step 15.

13. Remove valve seat inserts (Figure 9, Items 12 and 13). Use seat removal tool or machine inserts out of cylinder head.

INSPECTION/REPAIR - CONTINUED

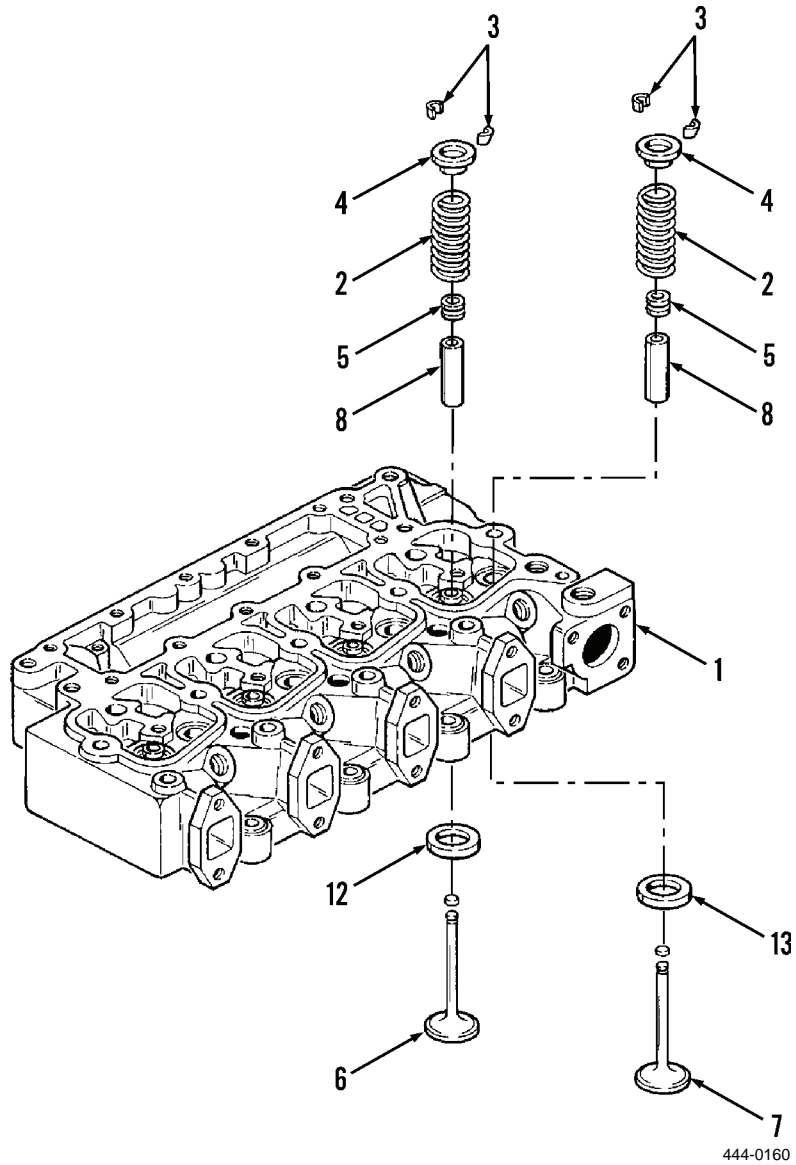

Figure 9. Cylinder Head and Valves.

444-0160

## INSPECTION/REPAIR - CONTINUED

**WARNING**

Dry ice is extremely cold and will immediately freeze skin. Use heavy gloves when handling dry ice and avoid any contact with unprotected skin. If injured, obtain medical aid immediately.

14. Cool and install valve seat inserts (Figure 11, Items 12 and 13). Clean valve seat insert recesses in cylinder head. Place new inserts in dry ice to shrink them, then install by pressing into cylinder block until bottomed in recess.
15. Install and check valve protrusion on intake valve (Figure 11, Item 7) and exhaust valve (Figure 11, Item 6) as shown (Figure 10). If protrusion is more than 0.005 in. (0.13 mm), valve and seat must be ground. Refer to *Valves and Valve Seat Refacing* in this work package.

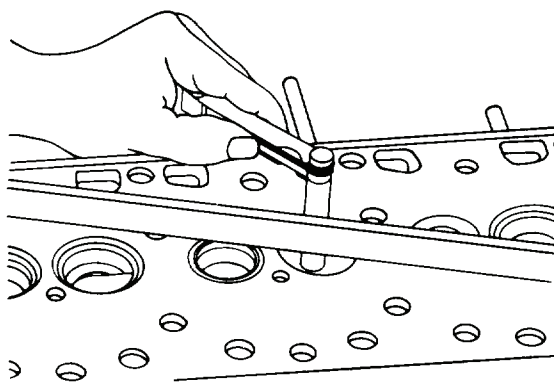

444-0364

**Figure 10. Measuring Valve Protrusion.**

INSPECTION/REPAIR - CONTINUED

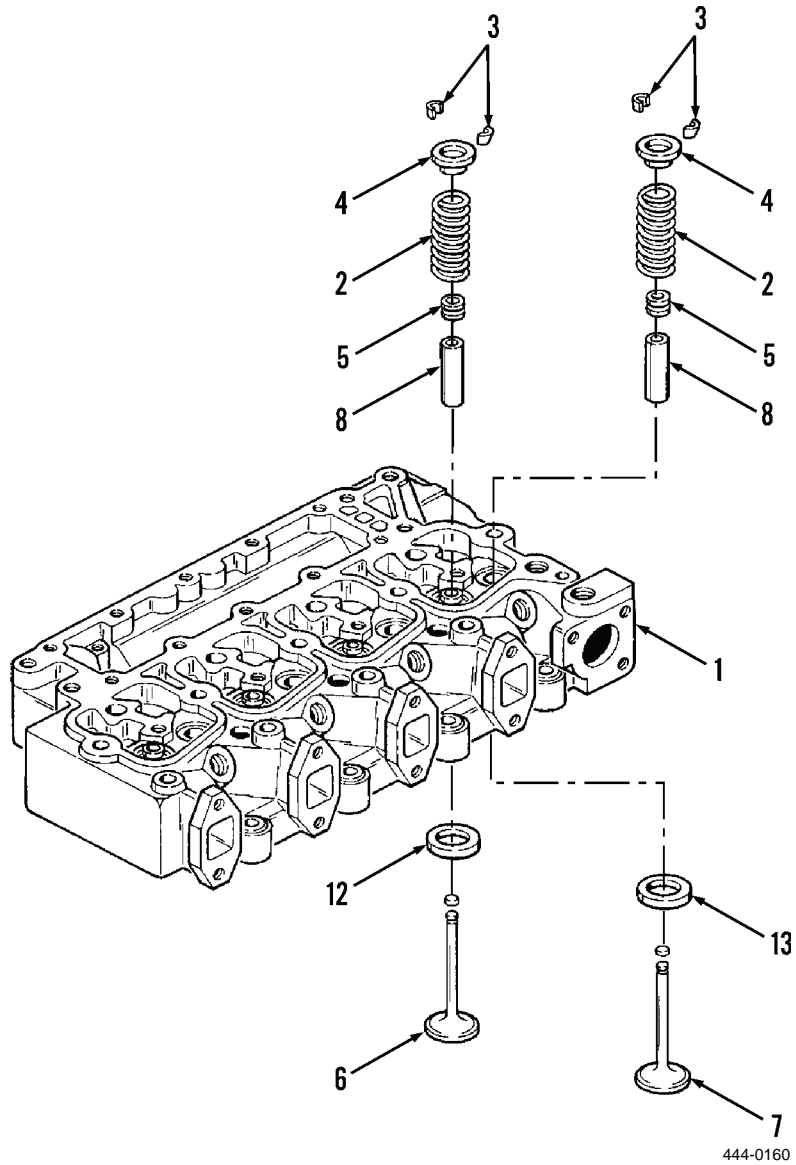

Figure 11. Cylinder Head and Valves.

END OF TASK

## VALVES AND VALVE SEAT REFACING

1. Set protractor at 44 degree angle for exhaust valves and 29 degree angle for intake valves.

### NOTE

Ensure jaws of chuck used to hold grinding wheel are clean and grinding wheel is accurately dressed.

2. Grind valves (Figure 13, Items 6 and 7) lightly at an angle of 44 degrees for exhaust valves and 29 degrees angle for intake valves.

### NOTE

Replace any valve that has a thin margin or edge. If margin on ground valve is less than half margin on new valve, replace that valve.

3. Grind valve seat (Figure 13, Items 12 and 13) inserts lightly, grinding angle as shown (Figure 12). Use precision seat grinder. Take very light cuts to remove just enough metal to obtain a smooth seat finish

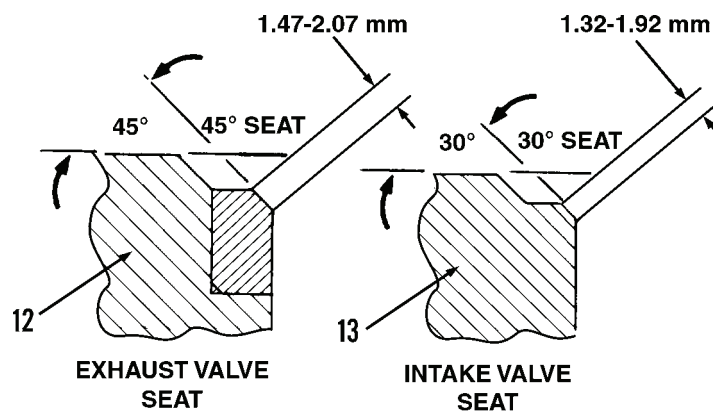

444-0365

Figure 12. Grinding Valve Seats.



### WARNING

Prussian Blue dye is poisonous and can burn skin on contact. Use in a well-ventilated area. Over-exposure to Prussian Blue dye can cause heart and skin problems, dizziness, and unconsciousness.

4. Apply prussian blue to faces of valves (Figure 13, Items 6 and 7).
5. Install valves (Figure 13, Items 6 and 7) in cylinder head (Figure 13, Item 1). Rotate valve in seat.
6. Check contact area on valve face and seat. Bluing will be removed from valve face where contact was made with seat. Correct and incorrect indications along with remedial procedures are shown below.

### NOTE

After valves and valve seat are ground, valve recession and protrusion must be rechecked (step 12 and 15, respectively, of *Inspection/Repair* in this work package).

## END OF TASK

**INSTALLATION**

1. Use clean engine oil to lubricate valve stems on bottom of cylinder head (Figure 13, Item 1).
2. Install valves (Figure 13, Items 6 and 7) in proper bore.
3. Install valve spring (Figure 13, Item 2) on valve stem seal (Figure 13, Item 5).
4. Install spring retainer (Figure 13, Item 4) on valve spring (Figure 13, Item 2).
5. Install valve stem seal (Figure 13, Item 5). Use valve spring compressor tool and compress spring. Install spring in lower stem groove.
6. Install two valve keepers (Figure 13, Item 3) on top valve stem groove. Remove valve spring compressor tool carefully and tap valve stem to seat valve keepers.

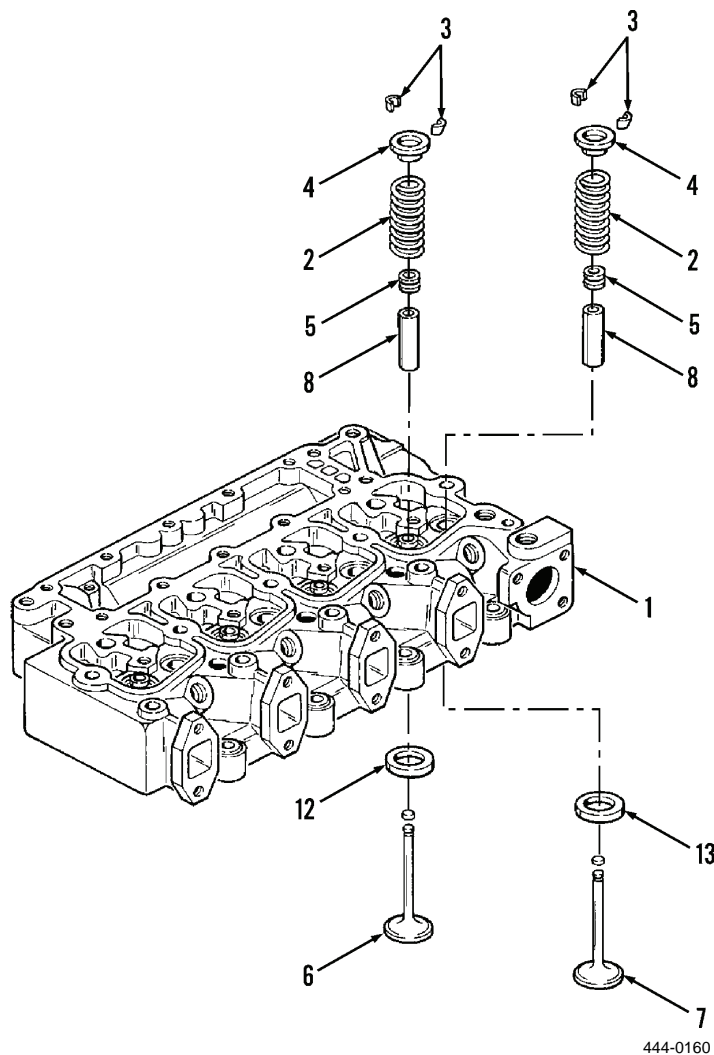

Figure 13. Cylinder Head and Valves.

**END OF TASK**

**END OF WORK PACKAGE**





# GENERAL SUPPORT MAINTENANCE INSTRUCTIONS

## CRANKSHAFT OIL SEAL RETAINER REPLACEMENT (MODEL 207)

### Removal, Cleaning, Inspection, Installation

#### INITIAL SETUP

##### Maintenance Level

General Support

##### Tools and Special Tools

Tool kit, general mechanic's (Item 15, WP 0309)  
 Shop equipment, common no. 1 (Item 2, WP 0309)  
 Aligning tool (P/N G13506)  
 Sleeve, 1-5/16-in. diameter  
 Sleeve tool (P/N G15028)

##### Materials/Parts

Cleaning compound, solvent (Item 10, WP 0310)

##### Materials/Parts - Continued

Lubricating oil, OE/HDO-15/40 (Item 21, WP 0310)  
 Rag, wiping (Item 26, WP 0310)  
 Permatex (Item 30, WP 0310)  
 Gasket  
 Lockwasher (7)  
 Oil seal

##### Equipment Condition

Flywheel and flywheel housing removed (WP 0278)

#### REMOVAL

#### NOTE

Note capscrew positioning for installation.

1. Remove seven capscrews (Figure 1, Items 1 and 2) and lockwashers (Figure 1, Item 3) from cylinder block. Discard lockwashers.
2. Remove crankshaft oil seal retainer assembly (Figure 1, Item 4) from cylinder block.
3. Remove and discard gasket (Figure 1, Item 5).
4. Use 2-7/8-in. diameter sleeve to remove oil seal (Figure 1, Item 6) from crankshaft oil seal retainer assembly (Figure 1, Item 4). Discard oil seal.

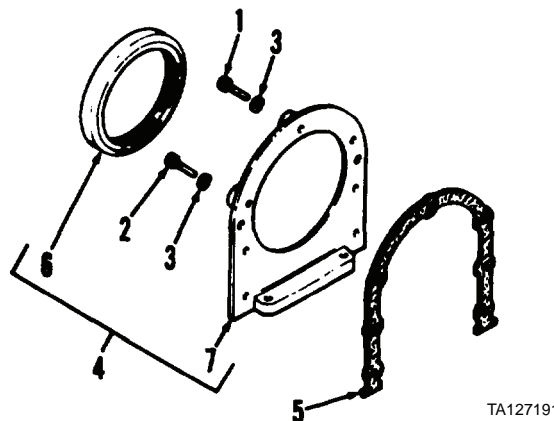

TA127191

Figure 1. Crankshaft Oil Seal and Retainer Assembly.

#### END OF TASK

**CLEANING**

- Solvent cleaning compound MIL-PRF-680 Type III is an environmentally compliant and low toxic material. However, it may be irritating to the eyes and skin. Use protective gloves and goggles. Use in well-ventilated areas. Keep away from open flames and other sources of ignition. Failure to do so may result in injury or death to personnel.
  - Particles blown by compressed air are hazardous. DO NOT exceed 15 PSI (103 kPa) nozzle pressure when drying parts with compressed air. DO NOT direct compressed air against human skin. Make sure air stream is directed away from user and other personnel in the area. To prevent injury, user must wear protective goggles or face shield. Failure to follow this warning may result in injury to personnel.
1. Use solvent cleaning compound to clean all other parts. Dry with moisture-free compressed air or clean rag.
  2. Remove traces of gasket from mating surfaces using solvent cleaning compound. Dry with moisture-free compressed air.

**END OF TASK****INSPECTION**

1. Inspect all parts. Check for cracks, damage, and distortion. Replace part if any of these conditions observed.
2. Inspect gasket (Figure 1, Item 5) area. Ensure all traces of gasket material are removed.

**END OF TASK****INSTALLATION**

1. Position rear oil seal retainer (Figure 1, Item 7) on press.
2. Press new oil seal (Figure 1, Item 6) into rear oil seal retainer (Figure 1, Item 7) until seal is flush with rear of retainer as shown in (Figure 2).

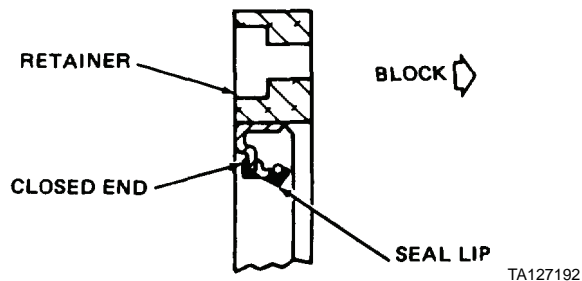

**Figure 2. Oil Seal Installation.**

**INSTALLATION - CONTINUED**

3. Apply Permatex 2 to lower screw holes in bottom of block as shown (Figure 3).
4. Install new gasket (Figure 1, Item 5) and apply Permatex 2 to lower screw holes in bottom of gasket as shown (Figure 3).

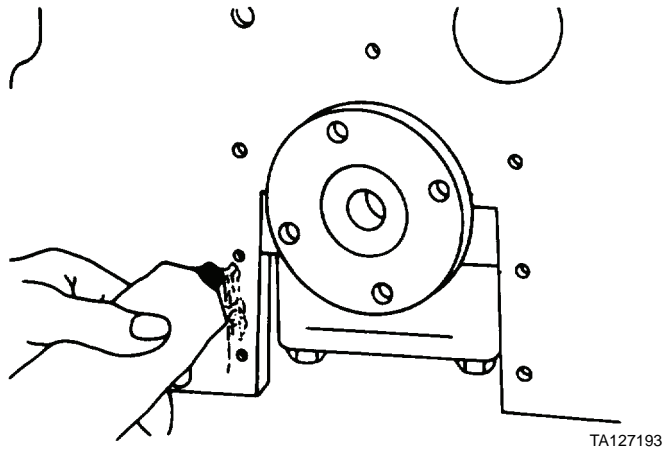

**Figure 3. Preparing Screw Holes with Permatex 2.**

5. Install sleeve tool as shown (Figure 4).

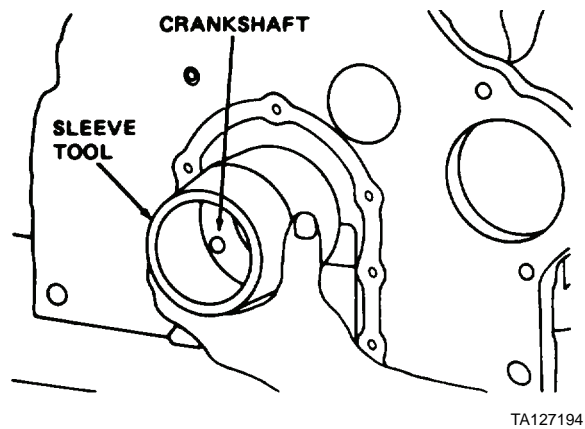

**Figure 4. Installing Gasket with Sleeve Tool.**

**INSTALLATION - CONTINUED**

6. Use clean engine oil to lubricate oil seal (Figure 5, Item 6).
7. Position crankshaft oil seal retainer assembly (Figure 5, Item 4) on engine and slide oil seal (Figure 5, Item 6) on sleeve until retainer assembly is against gasket (Figure 5, Item 5), then trim excess gasket material.

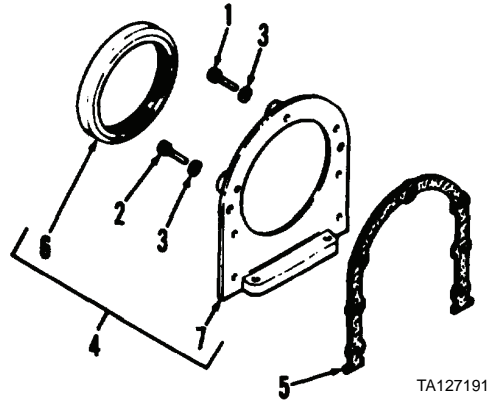

**Figure 5. Crankshaft Oil Seal and Retainer Assembly.**

8. Remove sleeve tool.
9. Install aligning tool with tool pins in aligning holes of retainer assembly (Figure 5, Item 4) and over crankshaft flange as shown (Figure 6).

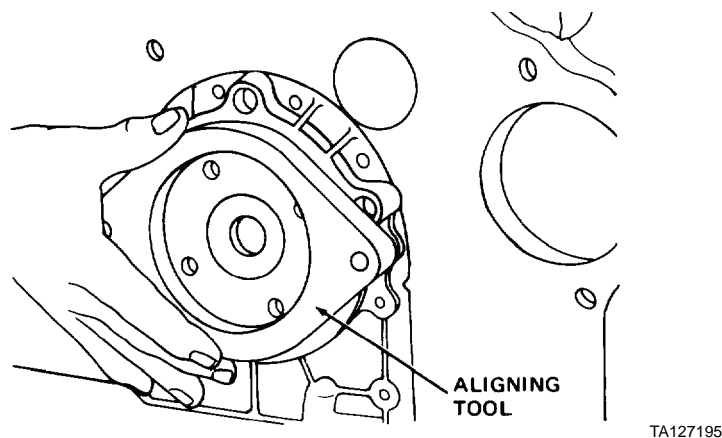

**Figure 6. Aligning Crankshaft with Aligning Tool.**

10. Install three capscrews (Figure 5, Item 2) and new lockwashers (Figure 5, Item 3) in top and two bottom holes of rear oil seal retainer (Figure 5, Item 7). Tighten capscrews until retainer assembly (Figure 5, Item 4) and gasket (Figure 5, Item 5) press firmly against cylinder block.
11. Remove aligning tool.
12. Install four capscrews (Figure 5, Item 1) and new lockwashers (Figure 5, Item 3) on rear oil seal retainer (Figure 5, Item 7). Tighten capscrews to 12 to 15 lb-ft (16 to 20 Nm).
13. Tighten three capcrews (Figure 5, Item 2) to 12 to 15 lb-ft (16 to 20 Nm).

**END OF TASK**

**END OF WORK PACKAGE**

---

**GENERAL SUPPORT MAINTENANCE INSTRUCTIONS**  
**CRANKSHAFT OIL SEAL RETAINER REPLACEMENT (MODEL 4-390)**  
**Removal, Cleaning, Inspection, Installation**

---

**INITIAL SETUP****Maintenance Level**

General Support

**Tools and Special Tools**

Tool kit, general mechanic's (Item 15, WP 0309)  
Shop equipment, common no. 1 (Item 2, WP 0309)  
Arbor press

**Materials/Parts**

Cleaning compound, solvent (Item 10, WP 0310)

**Materials/Parts - Continued**

Lubricating oil, OE/HDO-15/40 (Item 21, WP 0310)  
Rag, wiping (Item 26, WP 0310)  
Gasket  
Oil seal

**Equipment Condition**

Flywheel and flywheel housing removed (WP 0279)

---

**REMOVAL**

1. Loosen four capscrews (Figure 1, Item 1) on oil pan (Figure 1, Item 3) four revolutions each.
2. Remove four capscrews (Figure 1, Item 1) from oil pan (Figure 1, Item 3).
3. Separate bottom surface of oil seal retainer assembly (Figure 1, Item 2) from oil pan gasket (Figure 1, Item 5). Use feeler gage or thin shim stock.
4. Remove six capscrews (Figure 1, Item 4), oil seal retainer assembly (Figure 1, Item 2), and oil pan gasket (Figure 1, Item 5) from rear of engine. Discard oil pan gasket.
5. Remove seal (Figure 1, Item 6) from oil seal retainer (Figure 1, Item 7). Discard seal.

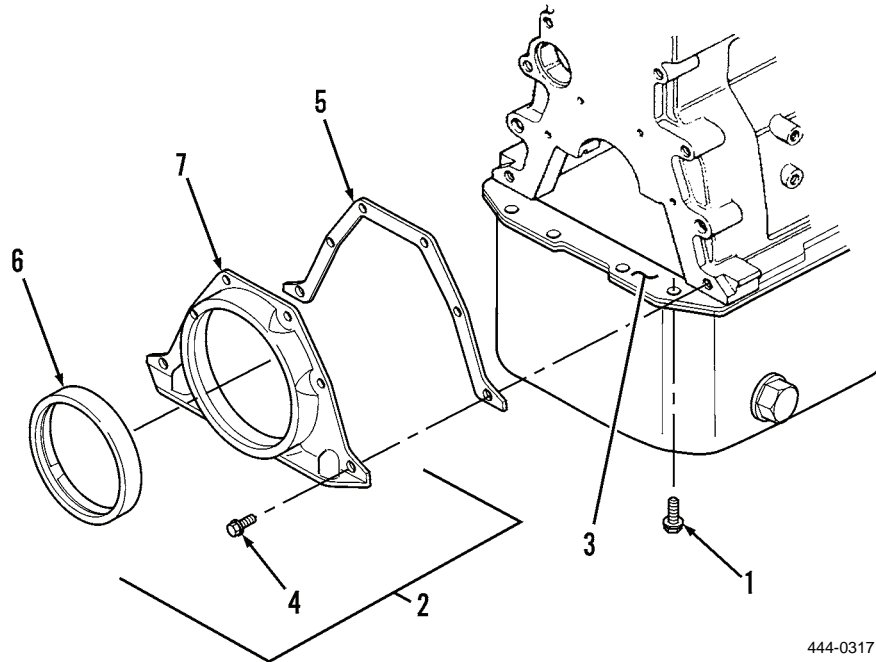

**Figure 1. Crankshaft Oil Seal and Retainer Assembly.**

**END OF TASK**

**CLEANING****WARNING**

- Solvent cleaning compound MIL-PRF-680 Type III is an environmentally compliant and low toxic material. However, it may be irritating to the eyes and skin. Use protective gloves and goggles. Use in well-ventilated areas. Keep away from open flames and other sources of ignition. Failure to do so may result in injury or death to personnel.
  - Particles blown by compressed air are hazardous. DO NOT exceed 15 PSI (103 kPa) nozzle pressure when drying parts with compressed air. DO NOT direct compressed air against human skin. Make sure air stream is directed away from user and other personnel in the area. To prevent injury, user must wear protective goggles or face shield. Failure to follow this warning may result in injury to personnel.
1. Use solvent cleaning compound to clean all parts. Dry with moisture-free compressed air or clean rags.
  2. Clean oil pan gasket (Figure 1, Item 5) area. Remove all traces of gasket material using solvent cleaning compound. Dry with moisture-free compressed air.

**END OF TASK****INSPECTION**

1. Inspect all parts. Check for cracks, damage, and distortion. Replace part if any of these conditions are observed.
2. Inspect oil pan gasket (Figure 1, Item 5) area. Ensure all traces of gasket material are removed.

**END OF TASK****INSTALLATION**

1. Use clean engine oil to lubricate surfaces of seal (Figure 1, Item 6) and install on oil seal retainer (Figure 1, Item 7).
2. Install new gasket (Figure 1, Item 5), oil seal retainer assembly (Figure 1, Item 2) and six capscrews (Figure 1, Item 4) on rear of engine. Tighten capscrews to 6.6 lb-ft (9 Nm).
3. Install four capscrews (Figure 1, Item 1) on oil pan (Figure 1, Item 3). Tighten capscrews to 15 to 20 lb-ft (20 to 27 Nm).

**END OF TASK****END OF WORK PACKAGE**





---

# GENERAL SUPPORT MAINTENANCE INSTRUCTIONS

## CRANKSHAFT AND MAIN BEARINGS REPLACEMENT (MODEL 207)

### Removal, Cleaning, Inspection, Installation

---

#### INITIAL SETUP

##### Maintenance Level

General Support

##### Tools and Special Tools

Tool kit, general mechanic's (Item 15, WP 0309)

Shop equipment, common no. 1 (Item 2, WP 0309)

##### Materials/Parts

Plastigage (Item 5, WP 0310)

Cleaning compound, solvent (Item 10, WP 0310)

Lubricating oil, OE/HDO-15/40 (Item 21, WP 0310)

Rag, wiping (Item 26, WP 0310)

Bore gage, 0 to 5 in.

##### Materials/Parts - Continued

Dial indicator

Gear and bearing heater

Heat-resistant gloves

Micrometer, 0 to 5 in.

Universal gear puller (NSN 5120-00-3784293)

##### Equipment Condition

Oil pan removed (WP 0226)

Cylinder head assembly removed (WP 0218)

Timing gear cover removed (WP 0284)

Oil pump removed (WP 0286)

Flywheel and flywheel housing removed (WP 0278)

Crankshaft oil seal retainer removed (WP 0274)

---

**REMOVAL**

1. Remove eight connecting rod nuts (Figure 1, Item 1) from cylinder block.

**NOTE**

Bearing liners are locked in groove of connecting rod bearing cap. Remove with cap as an assembly.

2. Remove four connecting rod bearing caps (Figure 1, Item 2) from cylinder block and set aside. Ensure cap and connecting rods are numbered as to location in block. Number cap and rod if necessary.

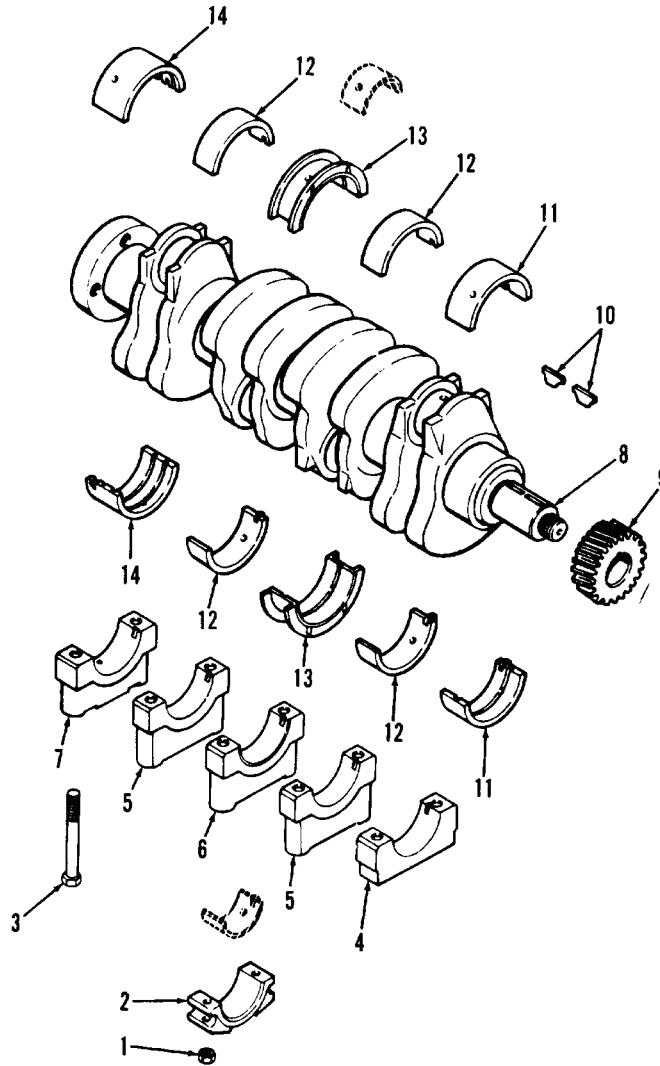

TA127209

**Figure 1. Crankshaft and Main Bearing Assembly.**

**REMOVAL - CONTINUED**

3. Remove 10 capscrews (Figure 1, Item 3).

**NOTE**

- Main bearing liners are locked in groove of main bearing caps. Remove with cap as an assembly.
  - Ensure main bearings caps are numbered for location in cylinder block. If necessary, number.
4. Remove front main bearing cap (Figure 1, Item 4) from cylinder block and set aside.
  5. Remove two intermediate main bearing caps (Figure 1, Item 5) from cylinder block and set aside.
  6. Remove center main bearing cap (Figure 1, Item 6) from cylinder block and set aside.
  7. Remove rear main bearing cap (Figure 1, Item 7) from cylinder block and set aside.
  8. Remove crankshaft (Figure 1, Item 8) from cylinder block as shown (Figure 2).

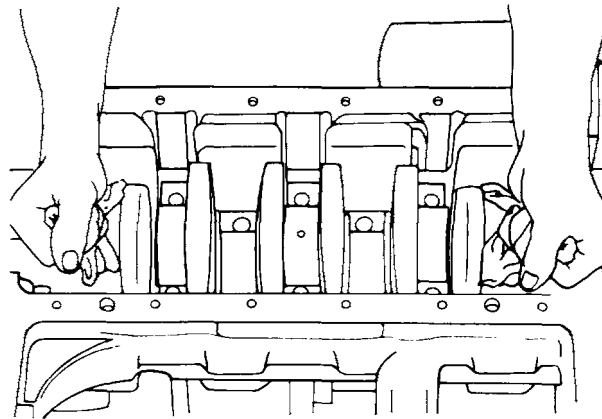

**Figure 2. Crankshaft Removal.**

9. Remove main bearing liners (Figure 1, Items 11, 12, 13, and 14) from cylinder block.
10. Use puller to remove crankshaft gear (Figure 1, Item 9) and two keys (Figure 1, Item 10) from crankshaft (Figure 1, Item 8).

**END OF TASK**

**CLEANING**



- Solvent cleaning compound MIL-PRF-680 Type III is an environmentally compliant and low toxic material. However, it may be irritating to the eyes and skin. Use protective gloves and goggles. Use in well-ventilated areas. Keep away from open flames and other sources of ignition. Failure to do so may result in injury or death to personnel.
- Particles blown by compressed air are hazardous. DO NOT exceed 15 PSI (103 kPa) nozzle pressure when drying parts with compressed air. DO NOT direct compressed air against human skin. Make sure air stream is directed away from user and other personnel in the area. To prevent injury, user must wear protective goggles or face shield. Failure to follow this warning may result in injury to personnel.

Use solvent cleaning compound to clean all other parts. Dry with moisture-free compressed air or clean rag.

**END OF TASK**

**INSPECTION**

1. Inspect key. Inspect for cracks, damage, and wear. Replace if cracked, damaged, or worn.
2. Inspect crankshaft. Inspect surfaces for rough or grooved condition. Inspect for scoring, pits, cracks, damage, and evidence of overheating. If any of these conditions observed, replace crankshaft.
3. Use micrometer to measure front and rear of each journal. If diameters are smaller than 2.8730 in. (72.974 mm), use undersize bearing liners (0.002 in. [0.05 mm]).

**NOTE**

When main bearing journals are worn more than 0.002 in. (0.05 mm), grind undersize to dimensions shown in Table 1.

**Table 1.**

<b>OUTER DIAMETER UNDERSIZE IN. (MM)</b>	<b>GRIND TO IN. (MM)</b>
0.002 (0.05)	2.2460 to 2.2470 (57.048 to 57.074)
0.010 (0.25)	2.2380 to 2.2390 (56.845 to 56.871)
0.020 (0.51)	2.2280 to 2.2290 (57.912 to 58.166)
0.030 (0.76)	2.2180 to 2.2190 (56.337 to 56.363)

**INSPECTION - CONTINUED****NOTE**

If one or more journals are to be ground, grind all journals.

4. Measure crankshaft main bearing journals 90 degrees from first measurement for out-of-roundness. If out-of-roundness exceeds 0.0005 in. (0.013 mm), regrind journal and use undersize liners.
5. Use micrometer to measure front and rear of each crankshaft connecting rod journal, checking taper. If taper exceeds 0.001 in. (0.03 mm), regrind journal.

**NOTE**

When connecting rod journals are worn more than 0.002 in. (0.05 mm), grind undersize to dimensions shown in Table 2.

**Table 2.**

<b>OUTER DIAMETER UNDERSIZE IN. (MM)</b>	<b>GRIND TO IN. (MM)</b>
0.002 (0.05)	2.2460 to 2.2470 (57.048 to 57.074)
0.010 (0.25)	2.2380 to 2.2390 (56.845 to 56.871)
0.020 (0.51)	2.2280 to 2.2290 (57.912 to 58.166)
0.030 (0.76)	2.2180 to 2.2190 (56.337 to 56.363)

**NOTE**

If one or more journals are to be ground, grind all journals.

6. Measure crankshaft connecting rod journals 90 degrees from first measurement for out-of-roundness. If out-of-roundness exceeds 0.0005 in. (0.013 mm), regrind journal.

**INSPECTION - CONTINUED****NOTE**

If crankshaft was reground, repeat steps 2 through 6 of *Inspection* in this work package.

7. Inspect crankshaft gear for cracks, scoring, pitting, flaking, or signs of overheating. Check liner back for bright spots. Replace if any of these conditions observed.
8. Remove center main bearing liners from center main bearing cap. Inspect for cracks, scoring, pitting, flaking, or signs of overheating. Check liner back for bright spots. Replace if any of these conditions observed.
9. Use micrometer to measure thrust surface thickness as shown (Figure 3). Replace if thickness less than 0.1025 in. (2.604 mm).

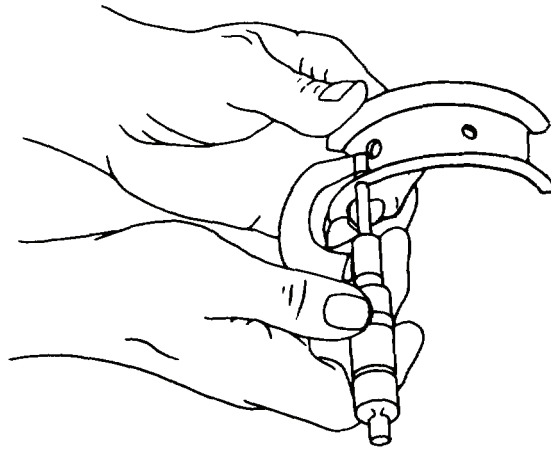

TA127211

**Figure 3. Measuring Thrust Bearing Thickness with Micrometer.**

10. Remove main bearing liners from main bearing caps. Inspect for cracks, scoring, pitting, flaking, or signs of overheating. Check liner back for bright spots. Replace if any of these conditions observed.
11. Inspect main bearings caps. Check for cracks, damage, wear, scoring, and pitting. Replace if any of these conditions observed.

## INSPECTION - CONTINUED

## NOTE

Perform step 12 for each main bearing cap requiring replacement. Proceed to *Installation* in this work package if original main bearing caps are being installed.

12. Position replacement main bearing cap in correct location, making sure lock notches are on same side as shown (Figure 4).

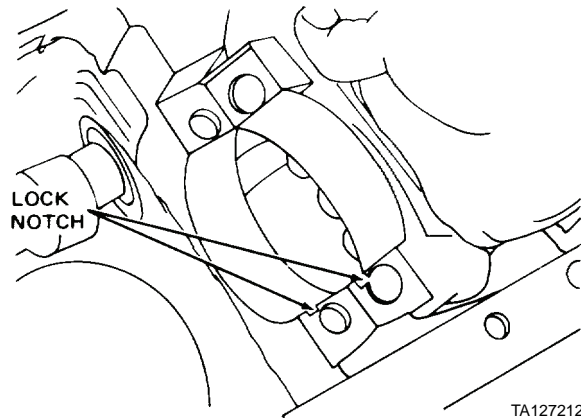

**Figure 4. Main Bearing Cap Installation.**

13. Install two capscrews on cylinder block. Tighten 90 to 100 lb-ft (122 to 136 Nm).
14. Check bore diameter of replacement main bearing cap at three angular locations as shown (Figure 5). Diameter should be 3.066 to 3.067 in. (77.88 to 77.90 mm).

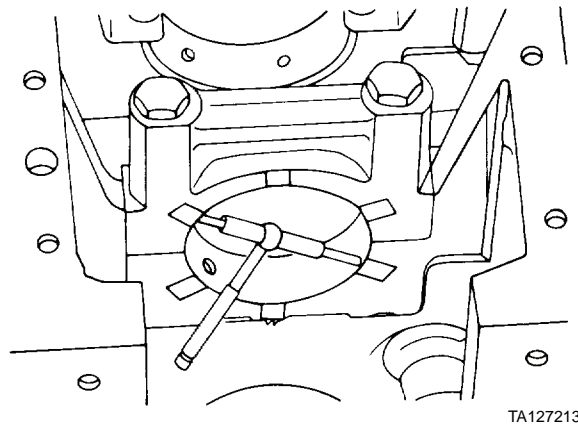
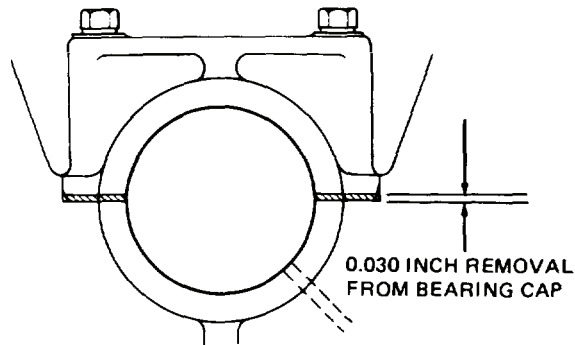

**Figure 5. Checking Bore Diameter.**

**INSPECTION - CONTINUED****NOTE**

If bore diameter is out of tolerance or main bearing cap is shifted sideways, perform steps 15 and 16; otherwise, proceed to step 17.

15. Remove two capscrews from cylinder block.
16. Remove and rework replacement main bearing cap. Rework by removing 0.030 in. (0.76 mm) stock from mating surface as shown (Figure 6). Then, bore out to meet tolerance specified in step 14. If 0.030 in. (0.76 mm) stock is removed, machine same amount from lock groove.



**Figure 6. New Main Bearing Cap Reworking.**

**NOTE**

Machine new mounting surface flat so main bearing cap will set solid without wobbling in cylinder block.

17. Remove two capscrews and replacement main bearing cap from cylinder block.

**END OF TASK**



## INSTALLATION

1. Position key on crankshaft.



### WARNING

Wear heat-resistant gloves to prevent burning your hands when performing step 2. If you burn your hands, obtain medical aid immediately.

2. Use gear and bearing heater to heat and install crankshaft gear. Timing mark on gear must be outward.
3. Clean bearing liner bore. Remove all dust, dirt, or grease. Dirt left behind bearing liners will interfere with lubrication and cooling, resulting in hot spots and premature failure of liners.
4. Install main bearing liners in cylinder block with liner lock engaging lock groove in block as shown (Figure 7). Slide liners into position.

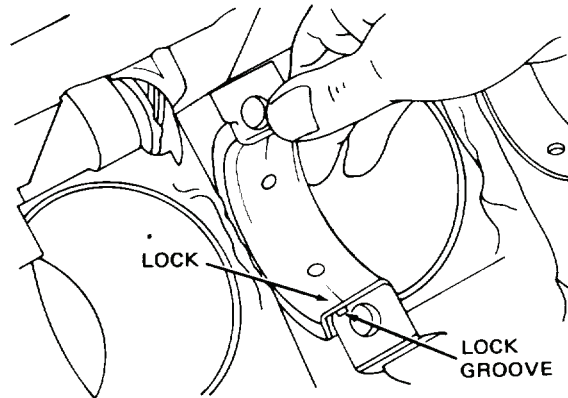

TA127215

**Figure 7. Thrust Bearing Installation.**

5. Install crankshaft and clean main bearing journals using clean, lint-free rag.
6. Position plastigage crosswise on crankshaft main bearing journals.

### NOTE

Install main bearing caps in proper numbered position with numbered side of cap toward camshaft.

7. Install main bearing liners in respective main bearing caps. Slide into position; do not press on center of liners. Make sure liner lock aligns with lock groove in main bearing cap as shown (Figure 7).
8. Install 10 capscrews on bearing caps, tighten to 90 to 100 lb-ft (122 to 136 Nm), then remove.
9. Remove main bearing caps and liners from cylinder block.
10. Measure flattened plastigage located on bearing cap liner or crankshaft. Measure widest point. Bearing oil clearance should be 0.0012 to 0.0042 in. (0.030 to 0.107 mm). If necessary, install undersize bearing liner kit or grind crankshaft (*refer to Inspection*, steps 2 through 6 in this work package).
11. Remove crankshaft from cylinder block.

**INSTALLATION - CONTINUED**

12. Use clean engine oil to lubricate bearing liner located in cylinder block bearing bores.
13. Install crankshaft in cylinder block.
14. Align timing marks on crankshaft gear with double marks on camshaft gear as shown (Figure 8).

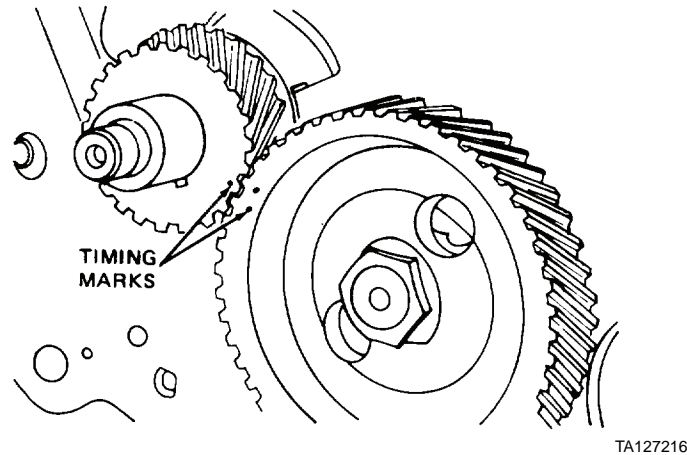
**Figure 8. Aligning Timing Marks.**

15. Use clean engine oil to lubricate bearing liners located in bore of main bearing caps.
16. Use No. 30 oil to lubricate main bearing journals.
17. Position main bearing caps and liners in cylinder block.
18. Install eight capscrews and tighten to 90 to 100 lb-ft (122 to 136 Nm).
19. Check end play of crankshaft:
  - a. Place dial indicator on crankshaft gear as shown (Figure 9). Using pry bar between crank throw and bearing cap, take up all end play and check dial indicator reading. Maximum end play is 0.015 in. (0.38 mm).
  - b. If end play is greater than this dimension, replace center main bearing liners and recheck end play. If end play is still greater than 0.015 in. (0.38 mm), replace crankshaft.

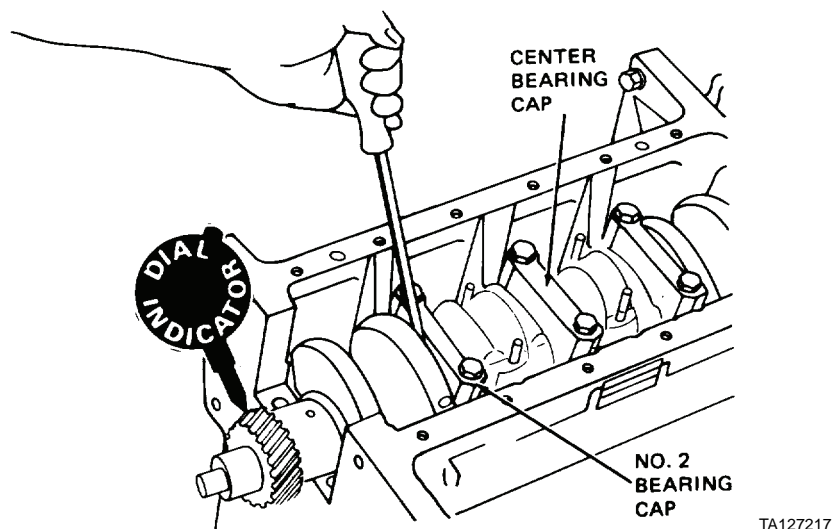
**Figure 9. Setting End Play.**

**INSTALLATION - CONTINUED**

20. Clean bearing liner with clean, lint-free rag; position plastigage crosswise on connecting rod bearing cap and liner.
21. Use clean, lint-free rag to clean crankshaft connecting rod journals in cylinder block.

**NOTE**

Install connecting rod bearing caps in proper numbered position with numbered side of cap towards camshaft.

22. Position four connecting rod bearing caps on cylinder block.
23. Install eight connecting rod nuts, tighten to 45 to 50 lb-ft (61 to 68 Nm), then remove.
24. Remove four connecting rod bearing caps from cylinder block.
25. Measure flattened plastigage located on bearing cap liner or crankshaft journal. Measure widest point. Oil clearance shall be 0.0010 to 0.0040 in. (0.025 to 0.102 mm). If necessary, install undersize bearing liners to obtain this dimension.
26. Use clean engine oil to lubricate bearing liner located in bore of connecting rod bearing cap.
27. Use No. 30 oil to lubricate connecting rod journals.
28. Position four connecting rod bearing caps in cylinder block.
29. Install eight connecting rod nuts and tighten to 45 to 50 lb-ft (61 to 68 Nm).
30. Position front main bearing cap on cylinder block.
31. Install oil pump (WP 0286).
32. Position dial indicator on camshaft gear as shown (Figure 10). Backlash between crankshaft gear and camshaft gear shall be 0.0002 to 0.006 in. (0.005 to 0.15 mm). If backlash exceeds 0.006 in. (0.15 mm), replace gears.

**NOTE**

Excessive backlash may also be caused by worn camshaft bushings.

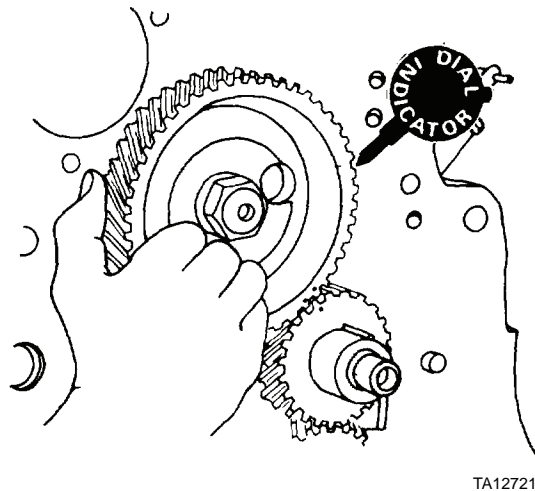

TA127218

**Figure 10. Measuring Backlash.**

**END OF TASK**

**END OF WORK PACKAGE**



---

## GENERAL SUPPORT MAINTENANCE INSTRUCTIONS

### CRANKSHAFT AND MAIN BEARINGS REPLACEMENT (MODEL 4-390)

#### Removal, Cleaning, Inspection, Installation

---

#### INITIAL SETUP

##### Maintenance Level

General Support

##### Tools and Special Tools

Tool kit, general mechanic's (Item 15, WP 0309)

Shop equipment, common no. 1 (Item 2, WP 0309)

Dial indicator

Gear and bearing heater

Heat-resistant gloves

Micrometer, 0 to 5 in.

Universal gear puller

##### Materials/Parts

Plastigage (Item 5, WP 0310)

##### Materials/Parts - Continued

Cleaning compound, solvent (Item 10, WP 0310)

Lubricating oil, OE/HDO-15/40 (Item 21, WP 0310)

Rag, wiping (Item 26, WP 0310)

##### Equipment Condition

Oil pan removed (WP 0227)

Cylinder head removed (WP 0219)

Timing gear cover removed (WP 0285)

Oil pump removed (WP 0287)

Flywheel and flywheel housing removed (WP 0279)

Crankshaft oil seal retainer removed (WP 0275)

Piston connecting rod nuts and caps removed (WP 0281)

---

**REMOVAL**

1. Remove 10 capscrews (Figure 2, Item 1) from main bearing caps (Figure 2, Items 2, 3, 4, and 5).

**NOTE**

- Main bearing liners are locked in groove of main bearing caps. Remove with cap as an assembly.
  - Ensure main bearing caps are numbered for location in cylinder block. If necessary, number.
2. Remove front main bearing cap (Figure 2, Item 2) from cylinder block and set aside.
  3. Remove two intermediate main bearing caps (Figure 2, Item 3) from cylinder block and set aside.
  4. Remove center main bearing cap (Figure 2, Item 4) from cylinder block and set aside.
  5. Remove rear main bearing cap (Figure 2, Item 5) from cylinder block and set aside.
  6. Remove crankshaft (Figure 2, Item 6) from cylinder block as shown (Figure 1).

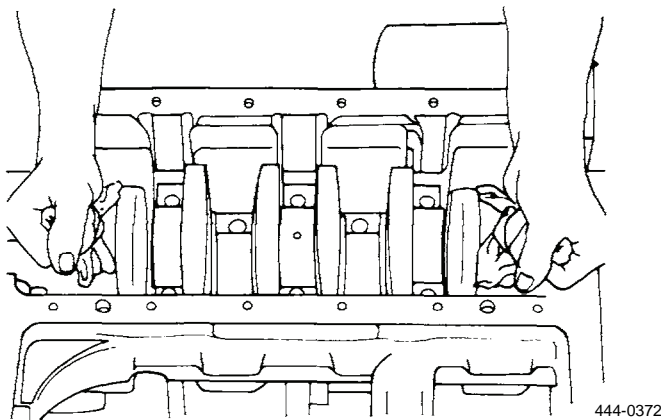
**Figure 1. Crankshaft Removal.**

7. Remove main bearings (Figure 2, Items 7, 8, 9, 10, and 11) from cylinder block.
8. Use puller to remove crankshaft from crankshaft gear (Figure 2, Item 12).
9. Remove pin (Figure 2, Item 13) from crankshaft (Figure 2, Item 6).

**END OF TASK****CLEANING****WARNING**

- Solvent cleaning compound MIL-PRF-680 Type III is an environmentally compliant and low toxic material. However, it may be irritating to the eyes and skin. Use protective gloves and goggles. Use in well-ventilated areas. Keep away from open flames and other sources of ignition. Failure to do so may result in injury or death to personnel.
- Particles blown by compressed air are hazardous. DO NOT exceed 15 PSI (103 kPa) nozzle pressure when drying parts with compressed air. DO NOT direct compressed air against human skin. Make sure air stream is directed away from user and other personnel in the area. To prevent injury, user must wear protective goggles or face shield. Failure to follow this warning may result in injury to personnel.

Use solvent cleaning compound to clean all parts. Dry thoroughly with moisture-free compressed air or clean rags.

CLEANING - CONTINUED

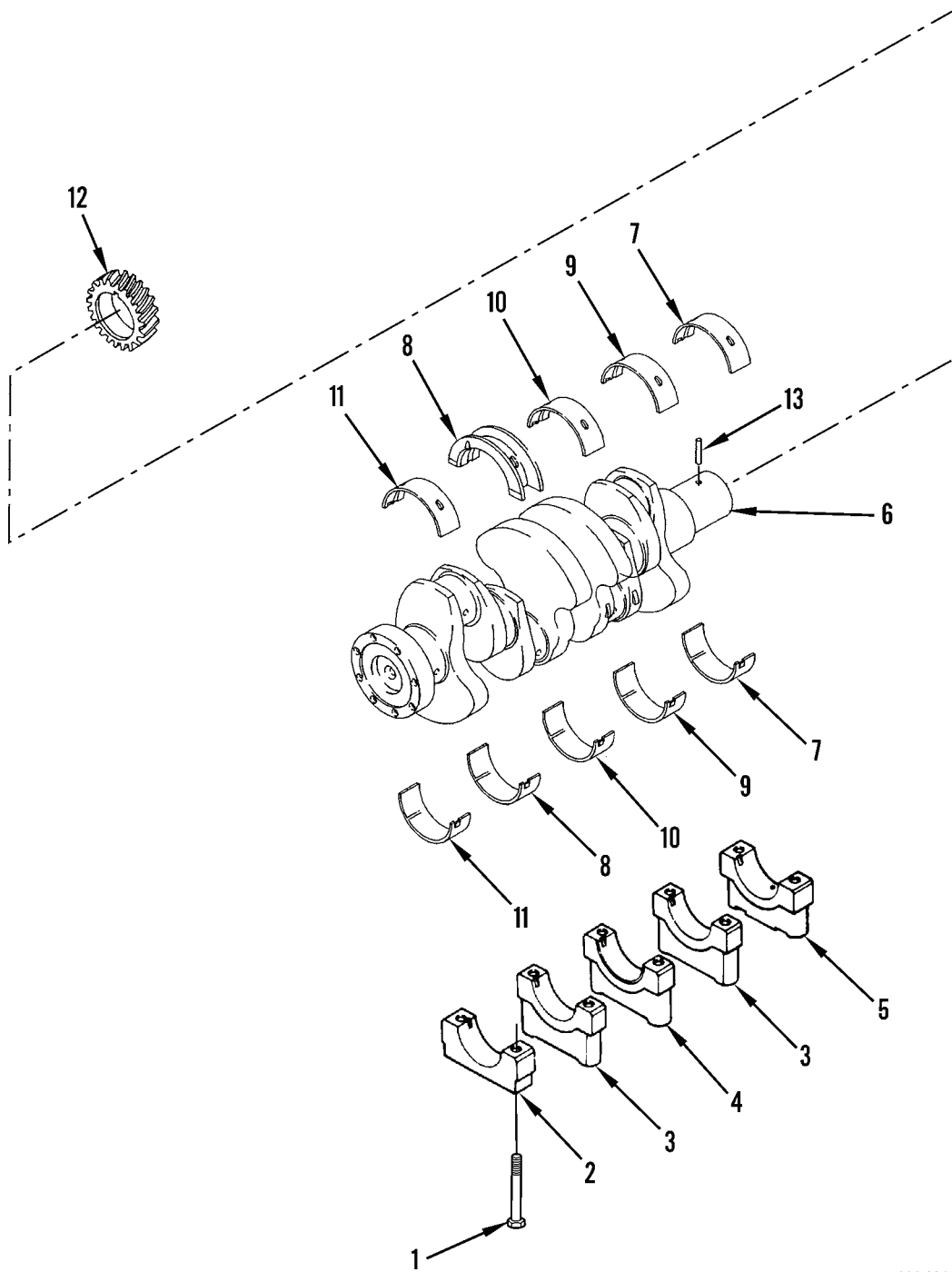

Figure 2. Crankshaft, Main Bearings, and Main Bearing Caps.

444-0318

END OF TASK

**INSPECTION**

1. Inspect key for cracks, damage, and wear. Replace if cracked, damaged, or worn.
2. Inspect crankshaft surfaces for rough or grooved condition. Inspect for scoring, pits, cracks, damage, and evidence of overheating. If any of these conditions are observed, replace crankshaft.
3. Use micrometer to measure crankshaft main bearing journals. Measure front and rear of each journal. If diameters are smaller than 2.8730 in. (72.974 mm), use undersized bearing (0.002 in. [0.05 mm]).

**NOTE**

When main bearing journals are worn more than 0.002 in. (0.05 mm), grind undersized to dimensions shown in Table 1.

**Table 1. Main Bearings Journals.**

<b>OUTER DIAMETER UNDERSIZE</b>	<b>GRIND TO</b>
0.002 in. (0.05 mm)	2.2460 to 2.2470 in. (57.048 to 57.074 mm)
0.010 in. (0.25 mm)	2.2380 to 2.2390 in. (56.845 to 56.871 mm)
0.020 in. (0.51 mm)	2.2280 to 2.2900 in. (57.912 to 58.166 mm)
0.030 in. (0.76 mm)	2.2180 to 2.2190 in. (56.337 to 56.363 mm)

**NOTE**

If one or more journals are to be ground, grind all journals.

4. Measure crankshaft main bearing journals 90 degrees from first measurement of out-of-roundness. If out-of-roundness exceeds 0.0005 in. (0.013 mm), regrind journal and use undersized.
5. Use micrometer to measure crankshaft connecting rod journals. Measure front and rear of each journal, checking taper. If taper exceeds 0.001 in. (0.03 mm), regrind journal.

**NOTE**

When connecting rod journals are worn more than 0.002 in. (0.05 mm), grind undersized to dimensions shown in Table 2.

**Table 2. Connecting Rod Journals.**

<b>OUTER DIAMETER UNDERSIZE</b>	<b>GRIND TO</b>
0.002 in. (0.05 mm)	2.2460 to 2.2470 in. (57.048 to 57.074 mm)
0.010 in. (0.25 mm)	2.2380 to 2.2390 in. (56.845 to 56.871 mm)
0.020 in. (0.51 mm)	2.2280 to 2.2900 in. (57.912 to 58.166 mm)
0.030 in. (0.76 mm)	2.2180 to 2.2190 in. (56.337 to 56.363 mm)



**INSPECTION - CONTINUED****NOTE**

If one or more journals are to be ground, grind all journals.

6. Measure crankshaft connecting rod journals 90 degrees from first measurement for out-of-roundness. If out-of-roundness exceeds 0.0005 in. (0.013 mm), regrind journal.

**NOTE**

If crankshaft was reground, repeat steps 2 through 6 of *Inspection* in this work package.

7. Inspect crankshaft gear for cracks, damage, missing or broken teeth, scoring, pits, and wear. If any of these conditions observed, replace gear.
8. Remove center main bearing from center main bearing cap (Figure 3, Item 4) and inspect for cracks, scoring, pitting, flaking, or signs of overheating. Check bearing back for bright spots. Replace if any of these conditions observed.
9. Use micrometer to measure thrust surface thickness as shown (Figure 3). Replace if thickness less than 0.1025 in. (2.604 mm).

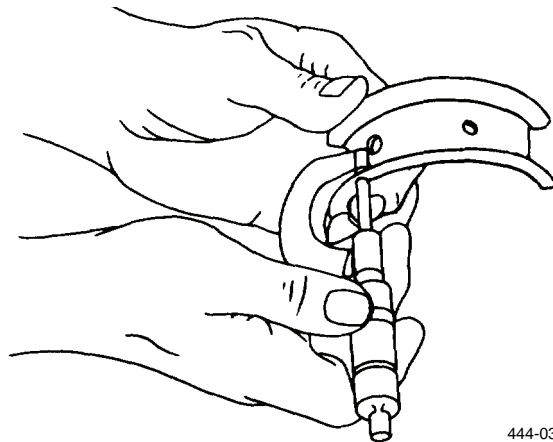

444-0373

**Figure 3. Measuring Thrust Bearing Thickness with Micrometer.**

**INSPECTION - CONTINUED**

10. Remove main bearings from main bearing caps and inspect for cracks, scoring, pitting, flaking, or signs of overheating. Check bearing back for bright spots. Replace if any of these conditions observed.
11. Inspect main bearing caps. Check for cracks, damage, wear, scoring, and pitting. Replace if any of these conditions observed.

**NOTE**

Perform step 12 for each main bearing cap requiring replacement. Proceed to *Installation*, step 15 in this work package, if original main bearing caps are being installed.

12. Position new main bearing cap in correct location at bottom of cylinder block. Be sure lock notches are on same side as shown (Figure 4).

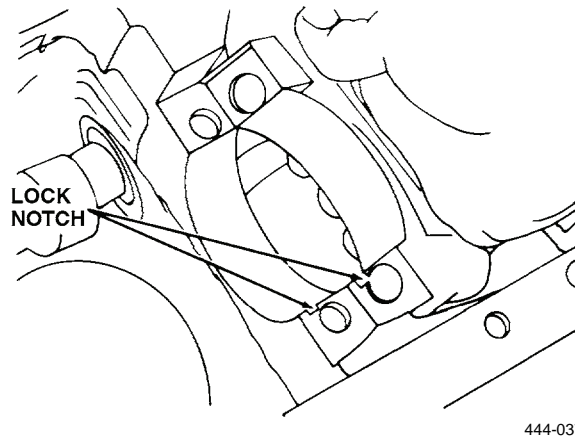

444-0374

**Figure 4. Positioning Main Bearing.**

13. Install two capscrews in main bearing cap. Tighten to 90 to 100 lb-ft (122 to 136 Nm).
14. Check bore diameter of new main bearing cap at three angular locations as shown (Figure 5). Diameter should be 3.066 to 3.067 in. (77.88 to 77.90 mm).

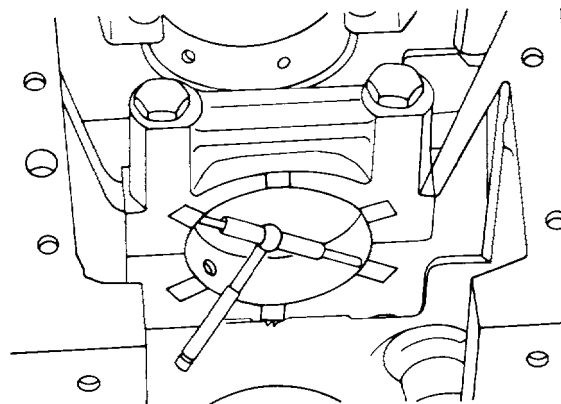

444-0375

**Figure 5. Measuring Bore Diameter.**

**INSPECTION - CONTINUED****NOTE**

If bore diameter is out of tolerance or main bearing cap is shifted sidewise, perform steps 15 and 16, otherwise, proceed to step 17.

15. Remove two capscrews from main bearing cap.
16. Remove and rework new main bearing cap. Rework by removing 0.030 in. (0.76 mm) stock from mating surface as shown (Figure 6). Then, bore out to meet tolerance specified in step 14. If 0.030 in. (0.76 mm) stock is removed, machine same amount from lock groove.

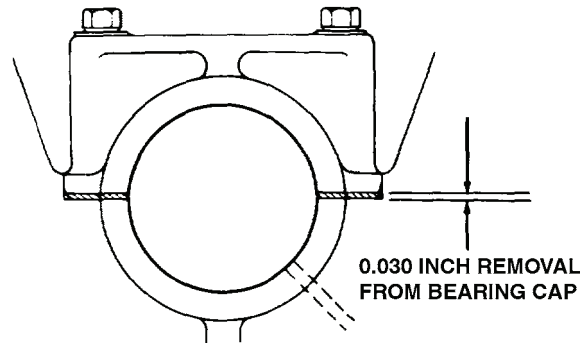

**Figure 6. New Main Bearing Cap Reworking.**

**NOTE**

Machine new mounting surface flat so main bearing cap will set solid without wobbling in cylinder block.

17. Remove two capscrews and new main bearing cap.

**END OF TASK**

## INSTALLATION

1. Position pinon crankshaft.



### WARNING

Wear heat resistant gloves to prevent burning your hands when performing step 2. If you burn your hands, obtain medical aid immediately. Failure to follow this warning may result in injury to personnel.

2. Use gear and bearing heater to heat and install crankshaft gear. Timing mark on gear must be outward.
3. Clean all dust, dirt, or grease from bearing bore and cylinder block. Dirt left behind bearings will interfere with lubrication and cooling, resulting in hot spots and premature failure of bearings.
4. Install main bearings in cylinder block, with bearing lock engaging lock groove in block as shown (Figure 7). Slide bearing into position.

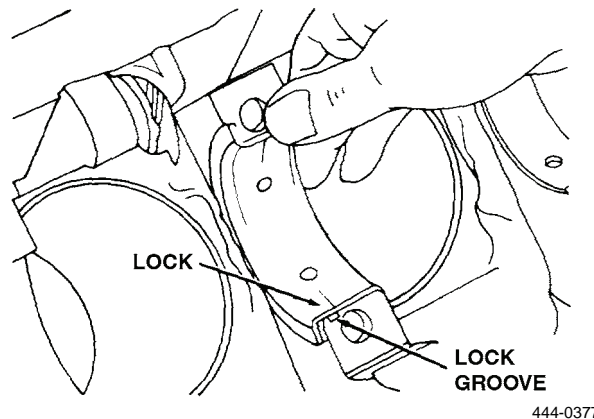

**Figure 7. Thrust Bearing Installation.**

5. Install and clean crankshaft. Clean main bearing journals using clean, lint-free rag.
6. Position plastigage crosswise on crankshaft main bearing journals.

### NOTE

Install main bearing caps in proper numbered position with numbered side of cap toward camshaft.

7. Install main bearing liners in respective main bearing caps. Slide into position; don't press on center of bearings. Be sure bearing lock aligns with lock groove in main bearing cap.
8. Install 10 capscrews, tighten to 90 to 100 lb-ft (122 to 136 Nm), then remove.
9. Remove main bearing cap and bearing from cylinder block.
10. Measure flattened plastigage located on bearing cap liner or crankshaft. Measure widest point. Bearing oil clearance should be 0.0012 to 0.0042 in. (0.030 to 0.107 mm). If necessary, install undersized bearing liner kit or grind crankshaft (refer to, *Inspection*, steps 2 through 6 in this work package).
11. Remove crankshaft from cylinder block.
12. Use clean engine oil to lubricate bearing liner located in cylinder block bearing bores.

**INSTALLATION - CONTINUED**

13. Install crankshaft on cylinder block.
14. Align timing marks on crankshaft gear with double marks on camshaft gear as shown (Figure 8).

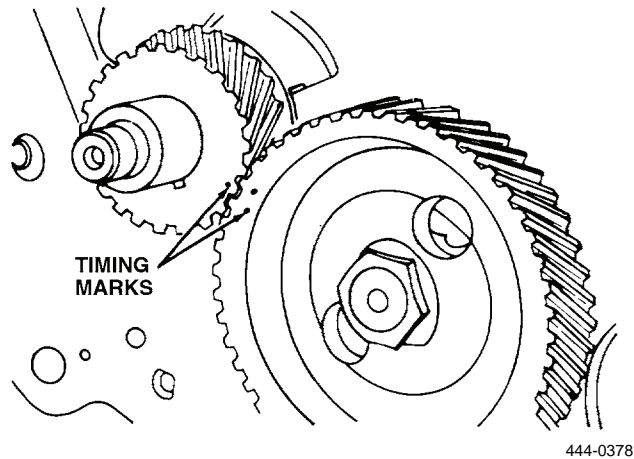
**Figure 8. Aligning Timing Marks.**

15. Use clean engine oil to lubricate main bearing cap bearing liners located in bores of bearing caps.
16. Use clean oil to lubricate main bearing journals.
17. Position main bearing caps and liners on cylinder block.
18. Install eight capscrews on main bearing caps. Tighten capscrews to 90 to 100 lb-ft (122 to 136 Nm).
19. Check end play of crankshaft.
  - a. Place dial indicator on crankshaft gear as shown (Figure 9). Use pry bar between crank throw and bearing cap to take up all end play and check dial indicator reading. Maximum end play is 0.015 in. (0.38 mm).
  - b. If end play is greater than specification, replace center main bearings and recheck end play. If end play is still greater than 0.015 in. (0.38 mm), replace crankshaft.

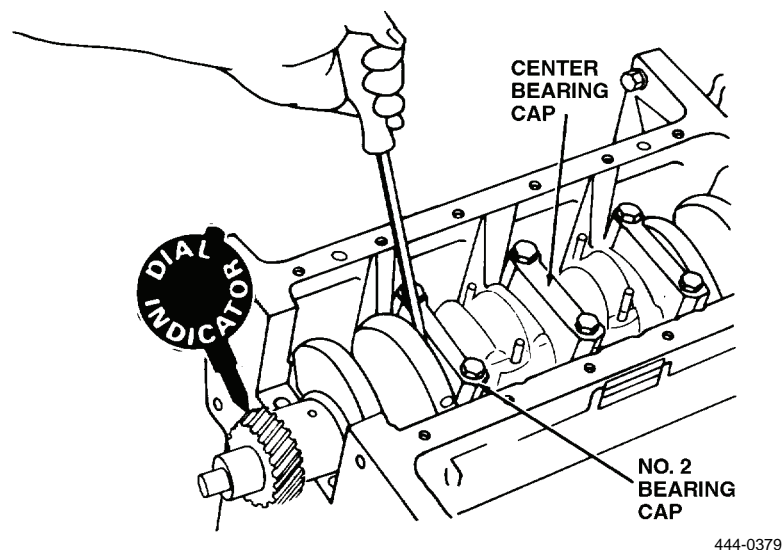
**Figure 9. Setting End Play.**

**INSTALLATION - CONTINUED**

20. Install connecting rod bearing caps, bearings, and nuts on cylinder block (WP 0281).
21. Install oil pump on cylinder block (WP 0287).
22. Check backlash crankshaft gear and camshaft gear. Place dial indicator on camshaft gear as shown (Figure 10). Backlash between gear and camshaft gear should be 0.0002 to 0.006 in. (0.005 to 0.152 mm). If backlash exceeds 0.006 in. (0.152 mm), replace gears.

**NOTE**

Excessive backlash may also be caused by worn camshaft bushings.

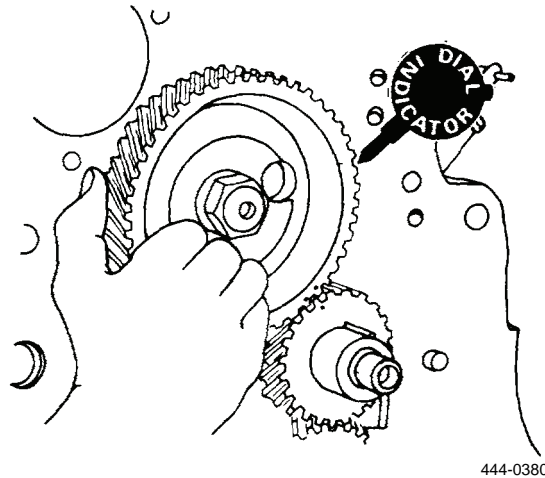

**Figure 10. Measuring Backlash.**

**END OF TASK**

**END OF WORK PACKAGE**

---

## GENERAL SUPPORT MAINTENANCE INSTRUCTIONS

### FLYWHEEL AND FLYWHEEL HOUSING REPLACEMENT (MODEL 207)

#### Removal, Cleaning, Inspection, Installation

---

#### INITIAL SETUP

**Maintenance Level**

General Support

**Tools and Special Tools**

Tool kit, general mechanic's (Item 15, WP 0309)

Chain hoist

Heat-resistant gloves

Oven or hot oil

**Materials/Parts**

Cleaning compound, solvent (Item 10, WP 0310)

Rag, wiping (Item 26, WP 0310)

Lockwasher (8)

**Equipment Condition**

Starter removed from engine (WP 0095)

Transmission separated from engine (WP 0213)

---

**REMOVAL**

1. Remove three capscrews (Figure 1, Item 1), lockwashers (Figure 1, Item 2), and washers (Figure 1, Item 3) from front of flywheel housing (Figure 1, Item 17). Discard lockwashers.
2. Remove dust cover (Figure 1, Item 4) from flywheel housing (Figure 1, Item 17).
3. Align timing mark on ring gear (Figure 1, Item 8) with roll pin (Figure 1, Item 19) in flywheel housing (Figure 1, Item 17). Insert screwdriver into timing hole in flywheel housing and engage ring gear teeth to move gear.
4. Remove four capscrews (Figure 1, Item 5) and washers (Figure 1, Item 6) from flywheel assembly (Figure 1, Item 7).
5. Remove flywheel assembly (Figure 1, Item 7) from flywheel housing (Figure 1, Item 17).
6. Use drift to drive ring gear (Figure 1, Item 8) off wheel (Figure 1, Item 9) and remove ring gear.
7. Remove capscrew (Figure 1, Item 10), lockwasher (Figure 1, Item 11), and cover (Figure 1, Item 12) from top of flywheel housing (Figure 1, Item 17). Discard lockwasher.
8. Remove two nuts (Figure 1, Item 13) and lockwashers (Figure 1, Item 14) from rear of flywheel housing (Figure 1, Item 17). Discard lockwashers.
9. Remove two capscrews (Figure 1, Item 15) and lockwashers (Figure 1, Item 16) from flywheel housing (Figure 1, Item 17). Discard lockwashers.
10. Use chain hoist securely fastened to flywheel housing (Figure 1, Item 17) to remove flywheel housing.
11. Remove two studs (Figure 1, Item 18) from flywheel housing (Figure 1, Item 17).
12. Remove roll pin (Figure 1, Item 19) from timing hole of flywheel housing (Figure 1, Item 17).

**END OF TASK****CLEANING****WARNING**

- Solvent cleaning compound MIL-PRF-680 Type III is an environmentally compliant and low toxic material. However, it may be irritating to the eyes and skin. Use protective gloves and goggles. Use in well-ventilated areas. Keep away from open flames and other sources of ignition. Failure to do so may result in injury or death to personnel.
- Particles blown by compressed air are hazardous. DO NOT exceed 15 PSI (103 kPa) nozzle pressure when drying parts with compressed air. DO NOT direct compressed air against human skin. Make sure air stream is directed away from user and other personnel in the area. To prevent injury, user must wear protective goggles or face shield. Failure to follow this warning may result in injury to personnel.

Use solvent cleaning compound to clean all other parts. Dry with moisture-free compressed air or clean rag.

**END OF TASK****INSPECTION**

1. Inspect ring gear (Figure 1, Item 8). Check for missing or chipped gear teeth or cracks; replace if any of these conditions observed.
2. Inspect flywheel (Figure 1, Item 9). Check for damage, wear, and elongated mounting holes; replace if any of these conditions observed.
3. Inspect flywheel (Figure 1, Item 17). Check for damage, wear, and elongated mounting holes; replace if any of these conditions observed.



**INSPECTION - CONTINUED**

4. Inspect roll pin (Figure 1, Item 19) in flywheel housing (Figure 1, Item 17). Check for bent condition; replace if bent. Tap new roll pin into position until seated in bottom of hole.
5. Inspect studs (Figure 1, Item 18) in flywheel housing (Figure 1, Item 17). Check for bent condition and deformed or damaged threads; replace if bent or threads damaged.

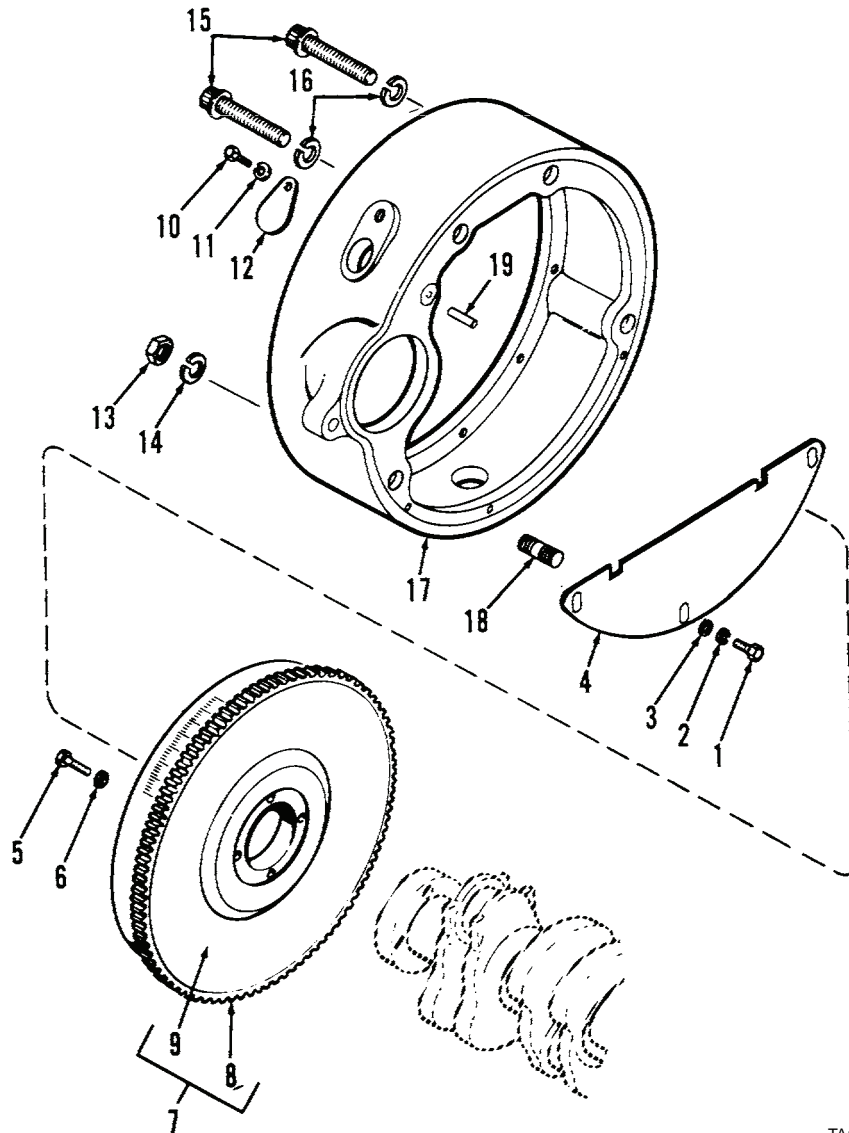

TA127189

**Figure 1. Flywheel and Flywheel Housing Assembly.****END OF TASK**

**INSTALLATION**

1. Install roll pin (Figure 2, Item 19) in timing hole.
2. Install two studs (Figure 2, Item 18) in flywheel housing (Figure 2, Item 17).
3. Use chain hoist to position flywheel housing (Figure 2, Item 17) on cylinder block.
4. Install two capscrews (Figure 2, Item 15) and new lockwashers (Figure 2, Item 16) on rear of flywheel housing (Figure 2, Item 17).
5. Install two nuts (Figure 2, Item 13) and new lockwashers (Figure 2, Item 14) on rear of flywheel housing (Figure 2, Item 17).
6. Position cover (Figure 2, Item 12) on top of flywheel housing (Figure 2, Item 17) and install capscrew (Figure 2, Item 10) and new lockwasher (Figure 2, Item 11).

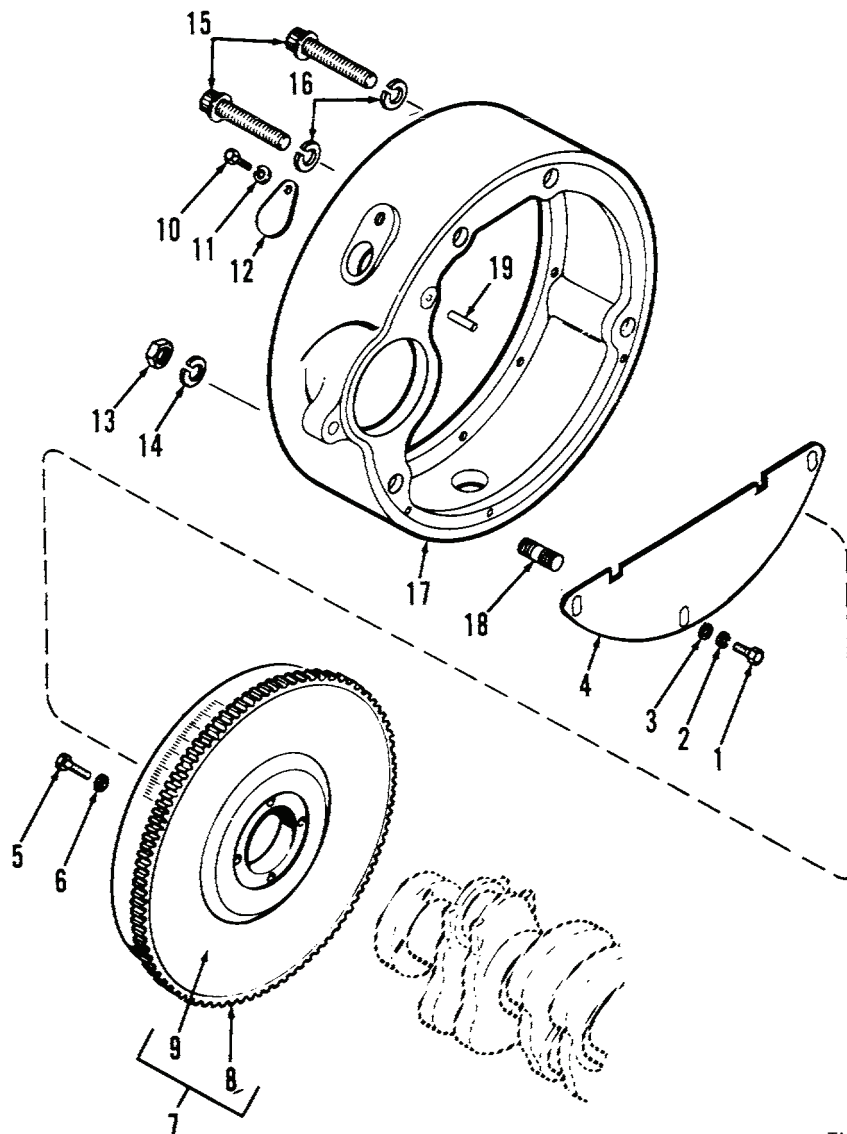

TA127189

**Figure 2. Flywheel and Flywheel Housing Assembly.**

**INSTALLATION - CONTINUED**

7. Position flywheel (Figure 2, Item 9) on work bench.

**WARNING**

Wear heat-resistant gloves to prevent burning your hands when handling heated parts. If you burn your hands, obtain medical aid immediately.

**CAUTION**

In step 8, do not use torch to preheat ring gear.

8. Use oven or hot oil and heat ring gear (Figure 2, Item 8) to 400 to 450°F (204 to 232°C). Install ring gear on flywheel (Figure 2, Item 9) with chamfer side of gear teeth outward and larger inside diameter chamfer toward flywheel as shown (Figure 3).

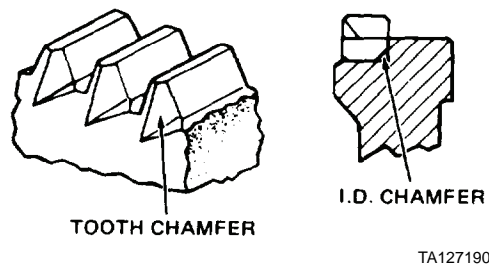

**Figure 3. Gear Tooth Chamfer.**

9. Position flywheel assembly (Figure 2, Item 7) on crankshaft and align timing mark and roll pin (Figure 2, Item 19) as noted during *Removal* in this work package.
10. Install four capscrews (Figure 2, Item 5) and washer (Figure 2, Item 6) on flywheel assembly (Figure 2, Item 7). Tighten capscrews to 65 to 70 lb-ft (88 to 95 Nm).
11. Position dust cover (Figure 2, Item 4) on front of flywheel housing (Figure 2, Item 17) and install three capscrews (Figure 2, Item 1), new lockwashers (Figure 2, Item 2), and washers (Figure 2, Item 3).

**END OF TASK**

**END OF WORK PACKAGE**



---

## GENERAL SUPPORT MAINTENANCE INSTRUCTIONS

### FLYWHEEL AND FLYWHEEL HOUSING REPLACEMENT (MODEL 4-390)

#### Removal, Cleaning, Inspection, Installation

---

#### INITIAL SETUP

**Maintenance Level**

General Support

**Tools and Special Tools**

Tool kit, general mechanic's (Item 15, WP 0309)

Chain hoist

Heat-resistant gloves

Oven or hot oil

**Materials/Parts**

Cleaning compound, solvent (Item 10, WP 0310)

**Materials/Parts - Continued**

Lubricating oil, OE/HDO-15/40 (Item 21, WP 0310)

O-ring (2)

**Personnel Required**

Two

**Equipment Condition**

Starter removed from engine (WP 0096)

Transmission separated from engine (WP 0214)

---

**REMOVAL**

1. Remove eight capscrews (Figure 1, Item 2), washers (Figure 1, Item 3), and flywheel (Figure 1, Item 4) from flywheel housing (Figure 1, Item 1).
2. Remove ring gear (Figure 1, Item 5) from flywheel (Figure 1, Item 4).
3. Remove plug (Figure 1, Item 6) and O-ring (Figure 1, Item 7) from flywheel housing (Figure 1, Item 1). Discard O-ring.
4. Remove plug (Figure 1, Item 8) from flywheel housing (Figure 1, Item 1).
5. Remove six capscrews (Figure 1, Item 9) from flywheel housing (Figure 1, Item 1).
6. Use chain hoist to remove flywheel housing (Figure 1, Item 1).
7. Remove O-ring (Figure 1, Item 10) from flywheel housing (Figure 1, Item 1). Discard O-ring.

**END OF TASK****CLEANING****WARNING**

- Solvent cleaning compound MIL-PRF-680 Type III is an environmentally compliant and low toxic material. However, it may be irritating to the eyes and skin. Use protective gloves and goggles. Use in well-ventilated areas. Keep away from open flames and other sources of ignition. Failure to do so may result in injury or death to personnel.
- Particles blown by compressed air are hazardous. DO NOT exceed 15 PSI (103 kPa) nozzle pressure when drying parts with compressed air. DO NOT direct compressed air against human skin. Make sure air stream is directed away from user and other personnel in the area. To prevent injury, user must wear protective goggles or face shield. Failure to follow this warning may result in injury to personnel.

Use solvent cleaning compound to clean all parts. Dry with moisture-free compressed air or clean rags.

**END OF TASK****INSPECTION**

1. Inspect ring gear (Figure 1, Item 5). Check for missing or chipped gear teeth or cracks; replace if any of these conditions observed.
2. Inspect flywheel (Figure 1, Item 4). Check for damage, wear and elongated mounting holes; replace if any of these conditions observed.
3. Inspect flywheel housing (Figure 1, Item 1). Check for cracks or other damage. Replace if cracked or damaged.

INSPECTION - CONTINUED

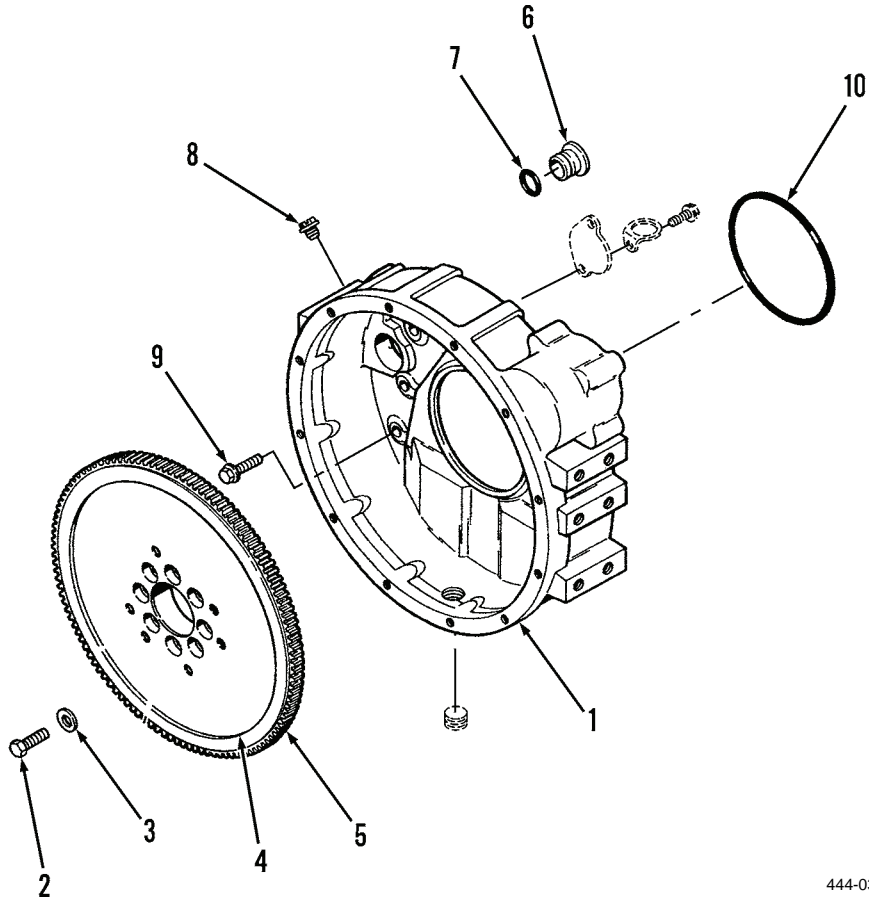

444-0316

Figure 1. Flywheel and Flywheel Housing Assembly.

END OF TASK

**INSTALLATION**

1. Install new O-ring (Figure 2, Item 10) on rear of flywheel housing (Figure 2, Item 1).
2. Use chain hoist to position flywheel housing (Figure 2, Item 1) on cylinder block.
3. Install six capscrews (Figure 2, Item 9) on flywheel housing (Figure 2, Item 1).
4. Install plug (Figure 2, Item 8) on flywheel housing (Figure 2, Item 1).
5. Install plug (Figure 2, Item 6) and new O-ring (Figure 2, Item 7) on flywheel housing (Figure 2, Item 1).

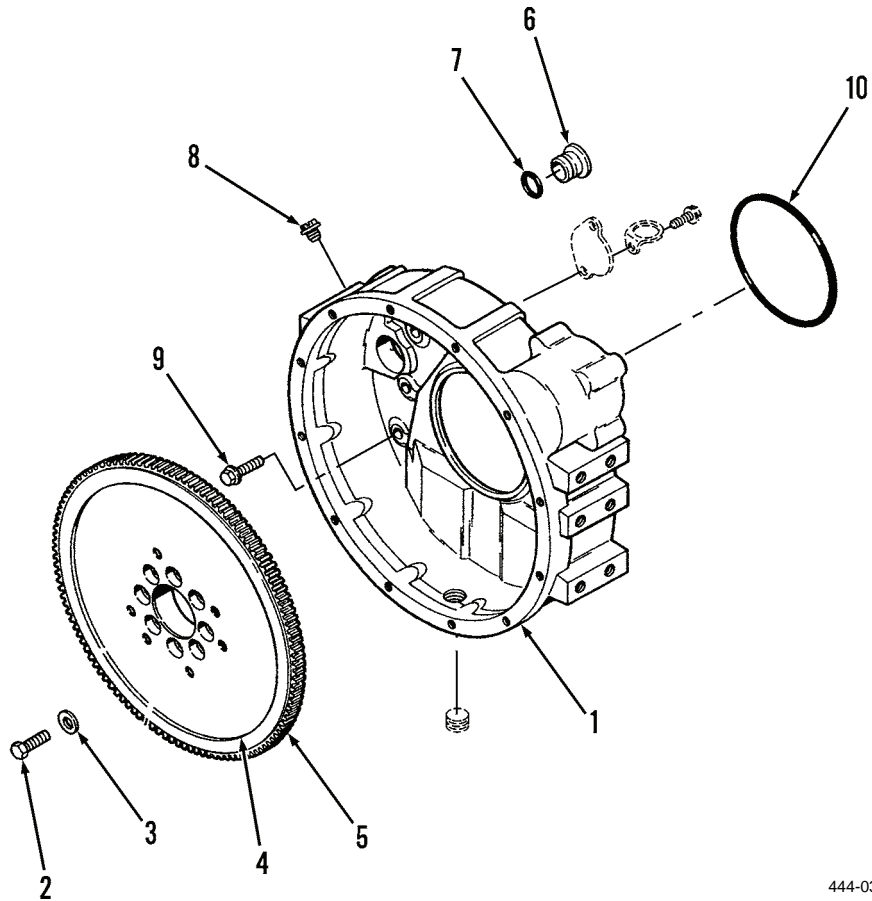

444-0316

**Figure 2. Flywheel and Flywheel Housing Assembly.**



**INSTALLATION - CONTINUED**

6. Position flywheel (Figure 2, Item 4) on work bench.

**WARNING**

Wear heat resistant gloves to prevent burning your hands when handling heated parts. If you burn your hands, obtain medical aid immediately.

**CAUTION**

In step 7, do not use torch to preheat ring gear.

7. Use oven or hot oil to heat ring gear (Figure 2, Item 5) to 400 to 450°F (204 to 232°C). Install ring gear on flywheel with chamfer side of gear teeth outward and larger inside diameter chamfer toward flywheel as shown (Figure 3).

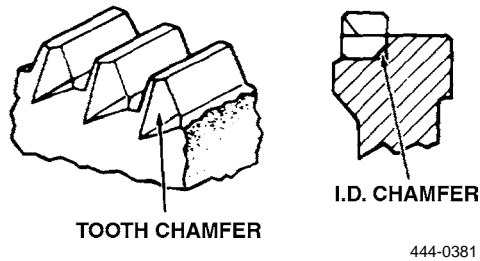

**Figure 3. Gear Tooth Chamfer.**

8. Position flywheel (Figure 2, Item 4) on crankshaft in same position as noted during *Removal* in this work package.
9. Install eight capscrews (Figure 2, Item 2) and washers (Figure 2, Item 3) on flywheel housing (Figure 2, Item 1). Tighten capscrews to 96 to 106 lb-ft (130 to 144 Nm).

**END OF TASK**

**END OF WORK PACKAGE**



---

## GENERAL SUPPORT MAINTENANCE INSTRUCTIONS

### PISTONS AND CONNECTING RODS MAINTENANCE (MODEL 207)

Removal, Disassembly, Cleaning, Inspection, Reassembly, Installation

---

#### INITIAL SETUP

##### Maintenance Level

General Support

##### Tools and Special Tools

Tool kit, general mechanic's (Item 15, WP 0309)

Shop equipment, common no. 1 (Item 2, WP 0309)

##### Materials/Parts

Plastigage (Item 5, WP 0310)

Cleaning compound, solvent (Item 10, WP 0310)

Lubricating oil, OE/HDO-15/40 (Item 21, WP 0310)

Rag, wiping (Item 26, WP 0310)

Bore gauge, 0 to 5 in.

Capscrew, 1/2-13 UNC, grade 5, 1-1/4 in. long (P/N 13-820)

##### Materials/Parts - Continued

Flat washer, 9/16 in. ID, 1-3/8 in. OD, 7/64 in. thick (P/N 95-8)

Groove cleaning tool

Micrometer, 0 to 5 in.

Piston ring

Piston ring compressor

Plastic scraper

Reamer

Sleeve, 1-5/16-in. diameter

Thickness gauge (NSN 5210-00-221-1999)

Wood dowel, 1-in. diameter

##### References

WP 0276

##### Equipment Condition

Oil pan removed (WP 0226)

Cylinder head removed (WP 0218)

---

**REMOVAL**

1. Use feeler gauge to check side clearance of four connecting rods (Figure 2, Item 3) at bottom of cylinder block. If clearance exceeds 0.0011 in. (0.28 mm), replace connecting rod.

**CAUTION**

Do not use sharp instruments to remove carbon ridge.

2. Check four piston sleeves at top of cylinder block. Inspect for carbon or metal ridge at top of ring travel. Use plastic scraper to remove carbon ridge as shown (Figure 2). If a metal ridge has formed, replace piston sleeve.
3. Check connecting rod (Figure 2, Item 3) and connecting rod cap (Figure 2, Item 2) at bottom of cylinder block. Check connecting rods and caps for numbers as to location in cylinder block. Number rods and caps for reinstallation in original location, if necessary.
4. Remove two connecting rod nuts (Figure 2, Item 1) from connecting rod cap (Figure 2, Item 2). Turn crankshaft to gain access to connecting rod caps.
5. Remove connecting rod cap (Figure 2, Item 2) and set aside.
6. Use wooden dowel to push connecting rod (Figure 2, Item 3) up through block.
7. Remove piston (Figure 2, Item 4) and connecting rod (Figure 2, Item 3) from top of cylinder block.
8. Install connecting rod caps (Figure 2, Item 2) and two nuts (Figure 2, Item 1) on corresponding connecting rods to avoid mixing caps.
9. Install capscrew (P/N 13-820) and washer (P/N 95-8) in cylinder block to hold piston sleeve in position as shown (Figure 2).

**NOTE**

Repeat steps 3 through 9 for three remaining connecting rods.

**END OF TASK****DISASSEMBLY****CAUTION**

Use piston ring expander to remove rings to avoid damaging piston and ring.

1. Use piston ring expander to remove top piston ring from piston as shown (Figure 1). Discard piston ring.
2. Remove and discard middle piston ring.
3. Remove and discard piston oil ring.
4. Remove two retaining rings (Figure 2, Item 8), piston pin (Figure 2, Item 9), and connecting rod (Figure 2, Item 3).

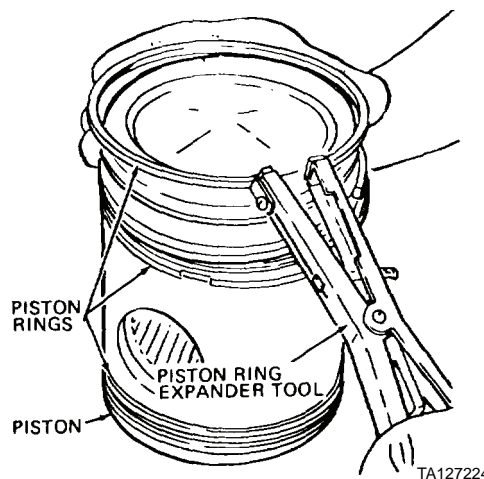
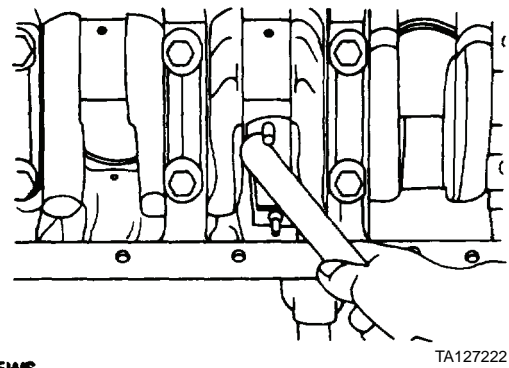
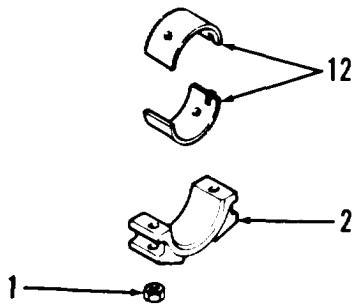
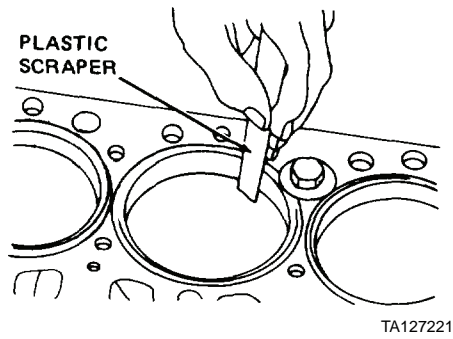
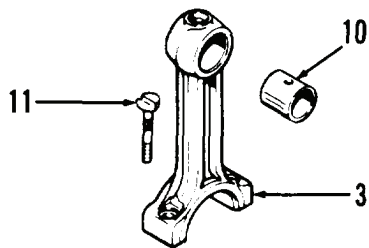
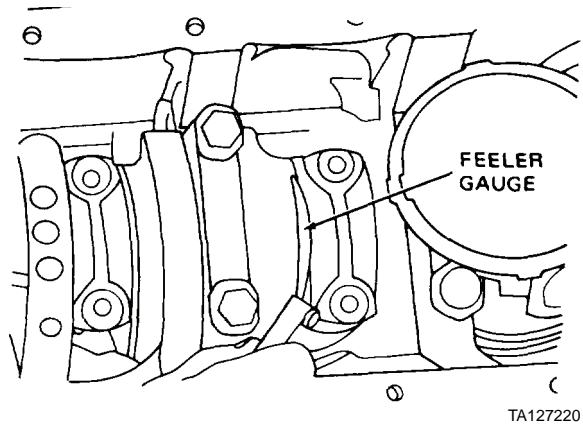
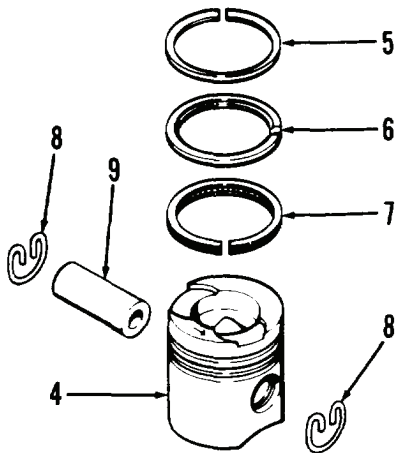

Figure 1. Expanding Piston Rings with Piston Ring Expander Tool.

DISASSEMBLY - CONTINUED



TA127219

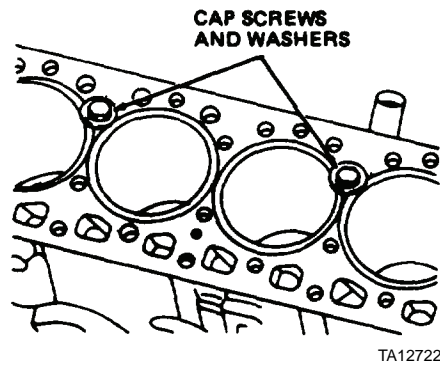

Figure 2. Pistons, Connecting Rods, and Bores.

END OF TASK

**CLEANING****WARNING**

- Solvent cleaning compound MIL-PRF-680 Type III is an environmentally compliant and low toxic material. However, it may be irritating to the eyes and skin. Use protective gloves and goggles. Use in well-ventilated areas. Keep away from open flames and other sources of ignition. Failure to do so may result in injury or death to personnel.
  - Particles blown by compressed air are hazardous. DO NOT exceed 15 PSI (103 kPa) nozzle pressure when drying parts with compressed air. DO NOT direct compressed air against human skin. Make sure air stream is directed away from user and other personnel in the area. To prevent injury, user must wear protective goggles or face shield. Failure to follow this warning may result in injury to personnel.
1. Use solvent cleaning compound to clean all other parts. Dry with moisture-free compressed air or clean rag.
  2. Remove carbon from piston, taking care not to scratch piston.
  3. Use groove cleaning tool to clean piston ring groove.
  4. Use small drill or fine wire to clean piston oil hole.

**END OF TASK**

## INSPECTION

1. Inspect piston. Inspect for cracks, damage, scoring, evidence of overheating, and damaged ring grooves. If any of these conditions observed, replace piston.
2. Use bore gauge and measure piston pin bore diameter in two places, 90 degrees apart. Replace piston if diameter is greater than 1.2508 in. (31.770 mm).
3. Use feeler gauge to measure oil ring side clearance as shown (Figure 3). If measurement exceed 0.005 in. (0.13 mm), replace part.

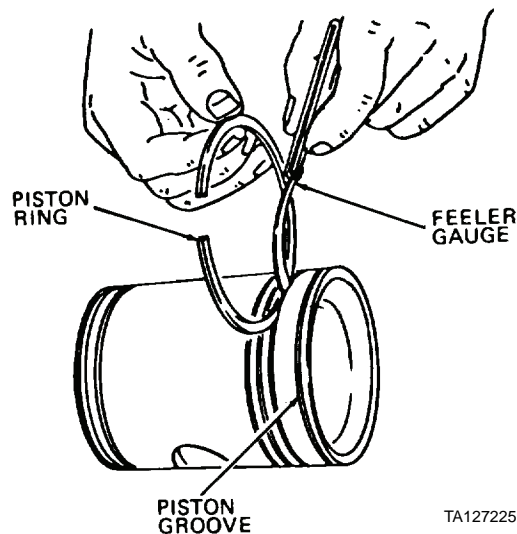

TA127225

**Figure 3. Measuring Piston Ring Side Clearance with Feeler Gauge.**

4. Use feeler gauge to measure second piston ring side clearance. If measurement exceeds 0.008 in. (0.20 mm), replace piston.

## NOTE

Top piston ring clearance cannot be checked.

5. Use micrometer to measure piston diameter. Measure across thrust face at bottom of piston, perpendicular to piston pin holes, as shown (Figure 4). If piston diameter is less than 3.9940 in. (101.448 mm), replace piston.
6. Use micrometer to measure outside diameter of piston pin as shown (Figure 4). Replace if measurement is less than 1.2495 in. (31.737 mm).

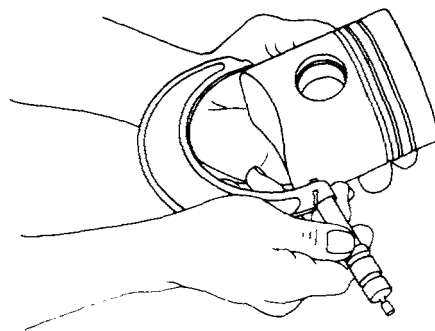

TA127226

**Figure 4. Measuring Piston Diameter with Micrometer.**

**INSPECTION - CONTINUED**

7. Inspect retaining rings (Figure 5, Item 8). Check for damage and loss of resiliency. Replace if damaged or resiliency is lost.

**NOTE**

Replace connecting rod as an assembly if side clearance check, performed in step 1 of *Removal* in this work package, exceeds 0.011 in. (0.28 mm).

8. Inspect connecting rod (Figure 5, Item 3) and connecting rod cap (Figure 5, Item 2). Check for cracks, damage, wear, scoring, and pitting. If any of these conditions observed, replace as an assembly.
9. Use bore gauge to measure inside diameter of piston pin bushing (Figure 5, Item 10), then measure bore gauge with micrometer. Replace if measurement is greater than 1.2510 in. (31.775 mm).

**NOTE**

Perform step 10 only if piston pin bushing requires replacement.

10. Use 1-5/16-in. diameter sleeve or rod to press piston pin bushing (Figure 5, Item 10) from connecting rod (Figure 5, Item 3). Align oil hole in replacement bushing with oil hole in connecting rod before pressing bushing in. Press until flush with rod. Ream bushing to 1.2502 to 1.2504 in. (31.755 to 31.760 mm) if new piston pin is to be installed; if old piston pin is used, ream bushing 0.0004 to 0.0015 in. (0.010 to 0.038 mm) larger than piston pin diameter.

**NOTE**

Avoid mixing bearing liners, connecting rods, and connecting rod caps. Inspect one group at a time.

11. Remove connecting rod nuts (Figure 5, Item 1) and screws (Figure 5, Item 11). Check for damaged threads and distortion. If distorted or threads damaged, replace part.
12. Remove and inspect bearing liners (Figure 5, Item 12). Check for scoring, pitting, flaking, cracking, or signs of overheating. Replace if any of these conditions observed.
13. Install connecting rod caps (Figure 5, Item 2), screws (Figure 5, Item 11), and nuts (Figure 5, Item 1) on corresponding connecting rods (Figure 5, Item 3) to avoid mixing caps.

**END OF TASK****ASSEMBLY**

1. Position connecting rod (Figure 5, Item 3) in piston (Figure 5, Item 4), numbered side of rod facing toward arrow side of piston.
2. Use hand pressure to install piston pin (Figure 5, Item 9) in piston (Figure 5, Item 4).
3. Install two retaining rings (Figure 5, Item 8) on piston pin (Figure 5, Item 9).

**CAUTION**

Use piston ring expander to install piston rings to prevent damaging rings or piston.

4. Install piston oil ring (Figure 5, Item 7) in piston third groove.
5. Install middle piston ring (Figure 5, Item 6) in piston second groove.
6. Install top piston ring (Figure 5, Item 5) in piston first groove.
7. Rotate piston rings (Figure 5, Items 5, 6, and 7) so ring end gaps are 120 degrees apart.
8. Remove two connecting rod nuts (Figure 5, Item 1) and connecting rod cap (Figure 5, Item 2).
9. Install connecting rod (Figure 5, Item 3).



**ASSEMBLY - CONTINUED**

10. Install bearing liner (Figure 5, Item 12). Do not push in on center of liner. Be sure liner lock engages connecting rod lock groove.

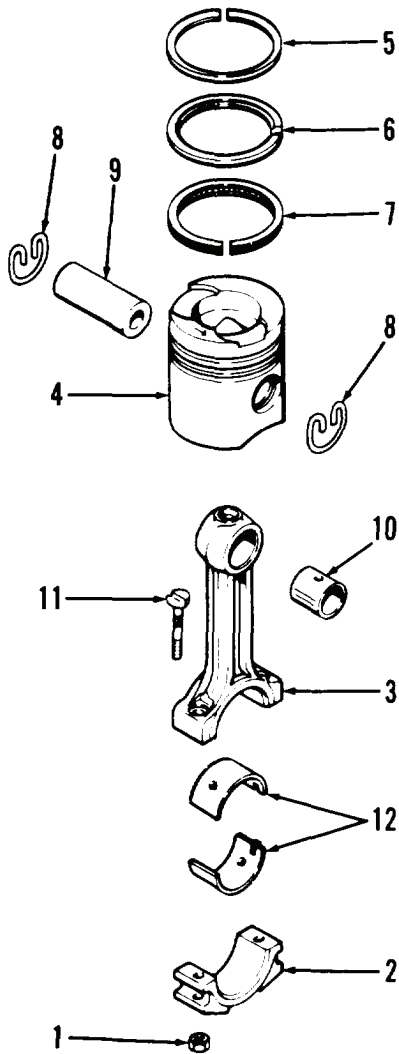

TA127219

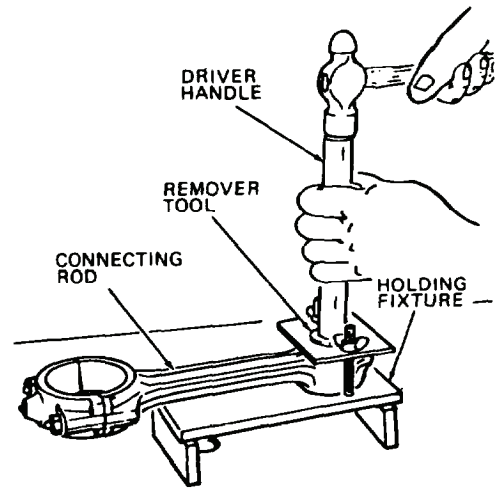

TA127228

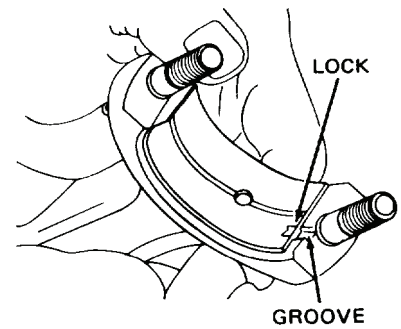

TA127229

**Figure 5. Piston and Connecting Rod Assembly.**

**END OF TASK**

## INSTALLATION

1. Measure front and rear connecting rod journals to check taper. Refinish journals if taper exceeds 0.001 in. (0.03 mm) (WP 0276).
2. Measure connecting rod journals 90 degrees from check points. If out-of-roundness exceeds 0.0005 in. (0.013 mm), refinish journals (WP 0276).
3. Use clean engine oil to lubricate piston rings (Figure 7, Items 5, 6, and 7) and piston (Figure 7, Item 4).
4. Use lubricating oil to lubricate cylinder sleeves.

### NOTE

Ensure stamped arrow on top of piston is pointed towards front of engine and numbers on bearing end of connecting rods face camshaft when performing step 5.

5. Position piston (Figure 7, Item 4) and connecting rod (Figure 7, Item 3) halfway in cylinder bore.

### NOTE

Ensure piston rings are fully seated in piston grooves.

6. Install piston ring compressor tool on piston (Figure 7, Item 4). Tighten a little at a time, making sure piston rings (Figure 7, Items 5, 6, and 7) are free to compress.
7. Install piston (Figure 7, Item 4). Gently tap down into cylinder block bore using wooden dowel as shown (Figure 6).
8. Remove piston ring compressor tool.

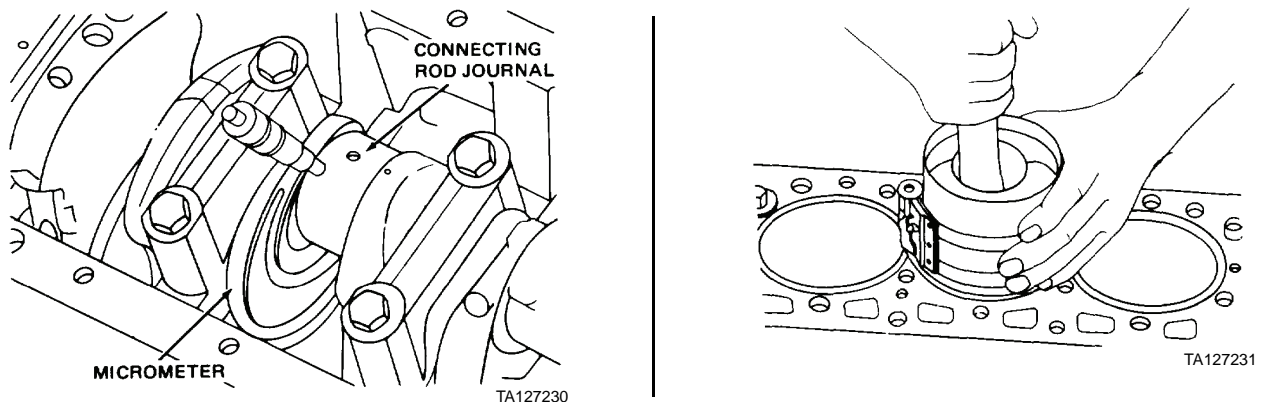

**Figure 6. Measuring Rod Journals and Piston Installation.**

9. Install bearing liner (Figure 7, Item 12) on connecting rod cap (Figure 7, Item 2).
10. Use clean rag to clean connecting rod journals.
11. Position plastigage crosswise on connecting rod cap liner (Figure 7, Item 12).

### NOTE

In step 12, be sure number on connecting rod cap matches number on connecting rod.

12. Position connecting rod cap (Figure 7, Item 2) and bearing liner (Figure 7, Item 12).
13. Install two connecting rod nuts (Figure 7, Item 1). Tighten nuts to 45 to 50 lb-ft (61 to 68 Nm), then remove.
14. Remove connecting rod cap (Figure 7, Item 2).
15. Measure flattened plastigage located on bearing liner (Figure 7, Item 12) or crankshaft connecting rod journal. Clearance should be 0.0010 to 0.0040 in. (0.025 to 0.102 mm). Install undersize bearing liner kit and regrind crankshaft journals if clearance exceeds 0.0040 in. (0.102 mm) (WP 0276).
16. Use clean lubricating oil to lubricate crankshaft connecting rod journals.

**INSTALLATION - CONTINUED**

17. Use clean lubricating oil to lubricate and position connecting rod caps (Figure 7, Item 2) and bearing liners (Figure 7, Item 12). Make sure numbers on caps (Figure 7, Item 2) and connecting rods (Figure 7, Item 3) match.
18. Install two connecting rod nuts (Figure 7, Item 1) and tighten to 45 to 50 lb-ft (61 to 68 Nm).

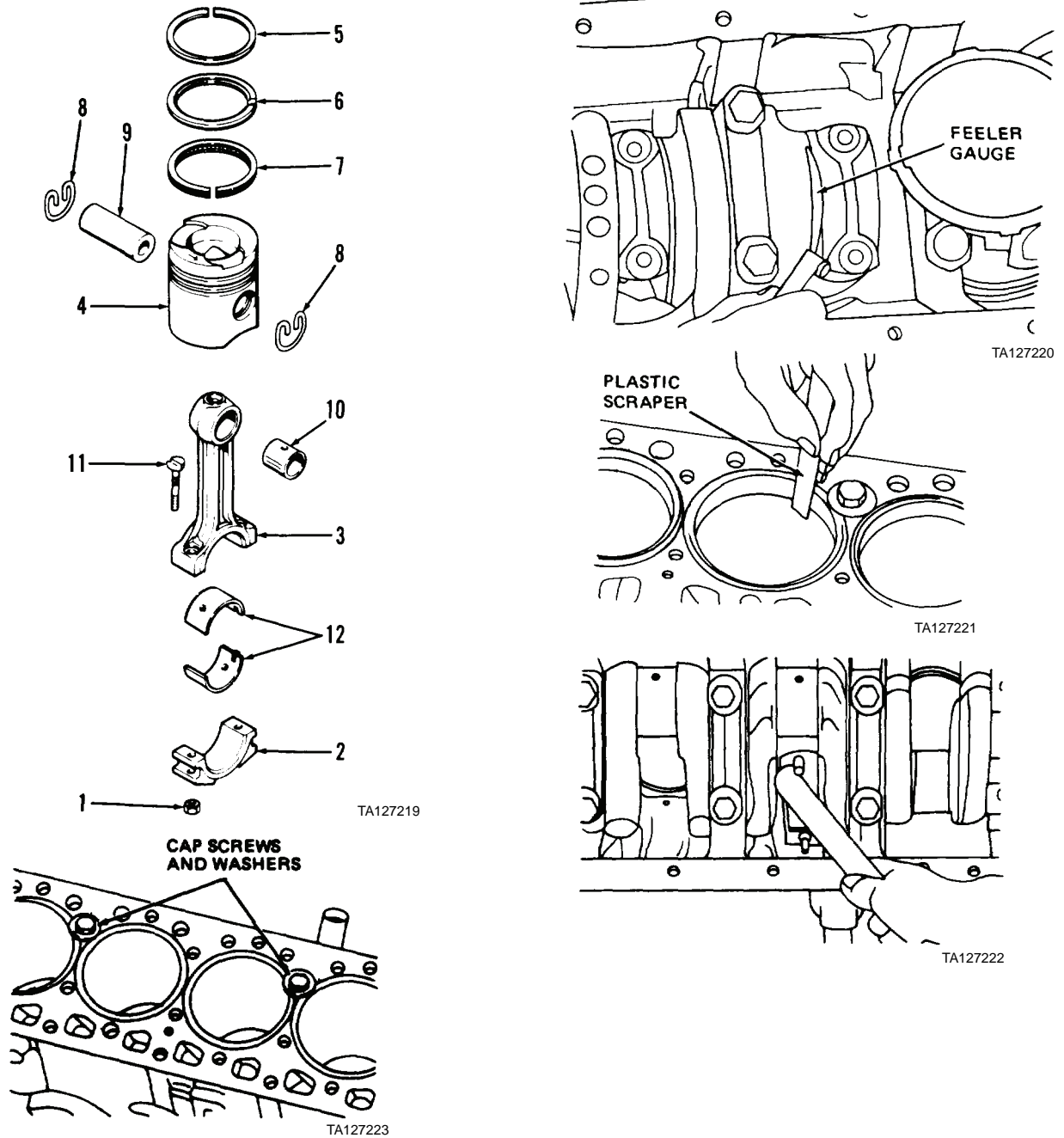

**Figure 7. Pistons, Connecting Rods, and Bores.**

19. Remove cylinder liner retaining capscrews and washers installed in step 9 of *Removal* in this work package.

**END OF TASK**

**END OF WORK PACKAGE**



---

## GENERAL SUPPORT MAINTENANCE INSTRUCTIONS

### PISTONS AND CONNECTING RODS MAINTENANCE (MODEL 4-390)

Removal, Disassembly, Cleaning, Inspection, Assembly, Installation

---

#### INITIAL SETUP

##### Maintenance Level

General Support

##### Tools and Special Tools

Tool kit, general mechanic's (Item 15, WP 0309)  
Shop equipment, common no. 1 (Item 2, WP 0309)  
Bore gauge, 0 to 5 in.  
Capscrew, 1/2-13 UNC, grade 5, 1-1/4 in. long (P/N 13-820)  
Connecting rod pin bushing removal and installation tool (CAS-10900)  
Dial indicator  
Flat washer, 9/16 in. ID, 1-3/8 in. OD, 7/64 in. thick (P/N 95-8)  
Micrometer, 0 to 5 in.  
Piston ring compressor  
Piston ring expander thickness gauge (NSN 5120-00-221-1999)

##### Tools and Special Tools - Continued

Plastic scraper  
Reamer  
Wood dowel, 1-in. diameter

##### Materials/Parts

Cleaning compound, solvent (Item 10, WP 0310)  
Lubricating oil, OE/HDO-15/40 (Item 21, WP 0310)  
Plastigage (Item 5, WP 0310)  
Rag, wiping (Item 26, WP 0310)  
Oil ring  
Piston ring

##### References

WP 0271

##### Equipment Condition

Oil pan removed (WP 0227)  
Cylinder head removed (WP 0219)

---

**REMOVAL**

1. Use feeler gauge to check side clearance of four connecting rods (Figure 1, Item 1). If clearance exceeds 0.03 in. (0.8 mm), replace connecting rod.

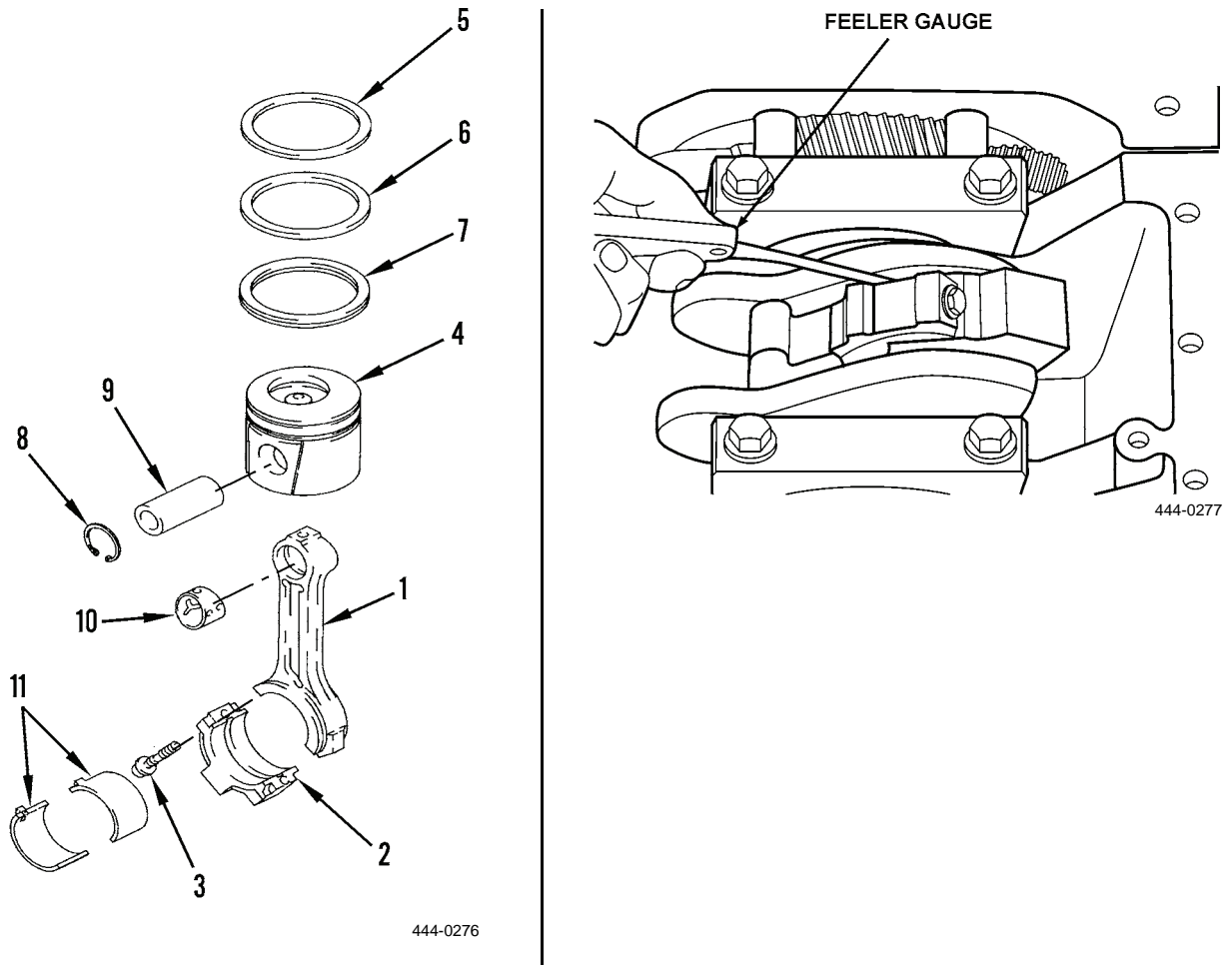
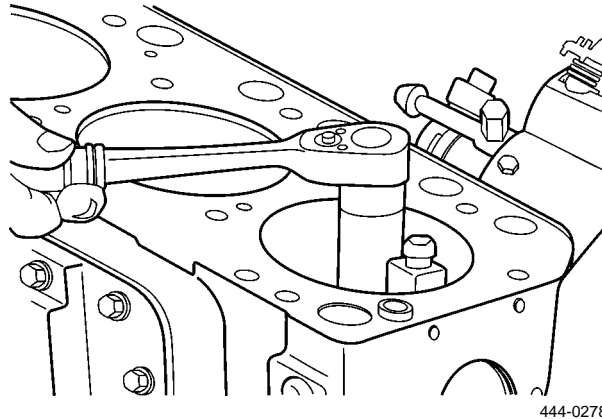

**Figure 1. Piston, Connecting Rod, and Measuring Side Clearance with Feeler Gauge.**

**REMOVAL - CONTINUED****CAUTION**

Do not use sharp instruments to remove carbon ridge.

2. Check four piston sleeves for carbon or metal ridge at top of ring travel. If a carbon ridge has formed, install ridge reamer and remove ridge from cylinder walls as shown (Figure 2). If a metal ridge has formed, replace piston sleeve (WP 0271).



**Figure 2. Removing Carbon or Metal Ridge from Cylinder Walls.**

3. Check connecting rods (Figure 1, Item 1) and connecting rod caps (Figure 1, Item 2) for numbers as to location in cylinder block. Number rods and caps for reinstallation in original location, if necessary.
4. Mark rod caps (Figure 1, Item 2) for identification.

**REMOVAL - CONTINUED**

5. Rotate crankshaft until pistons are below carbon deposits above ring travel area.

**CAUTION**

Be careful not to score cylinder while cleaning.

6. Clean cylinder with clean shop rag as shown (Figure 3).
7. Mark piston (Figure 4, Item 4) for identification.

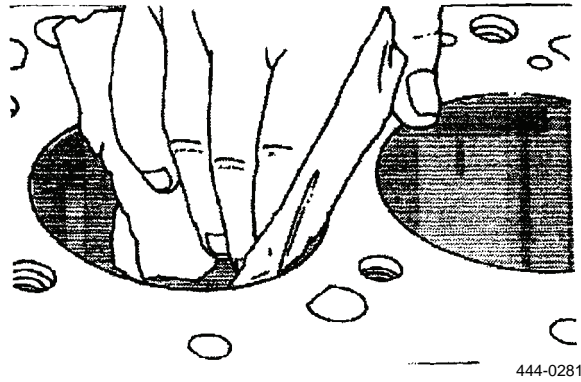

**Figure 3. Cleaning Cylinder.**

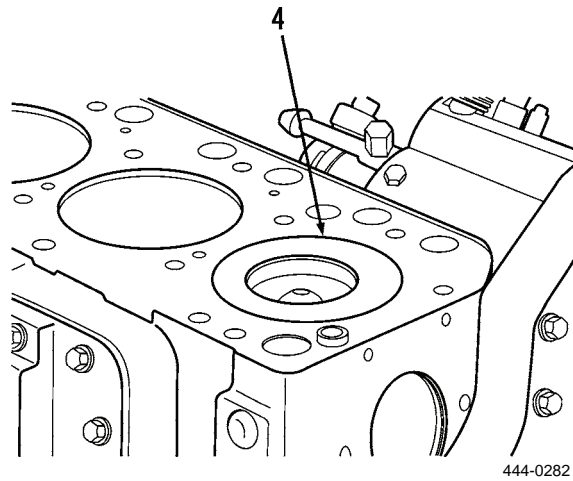

**Figure 4. Piston Set Below Carbon Deposits Above Ring Travel Area.**



**REMOVAL - CONTINUED**

8. Remove two connecting rod bolts (Figure 5, Item 3). Turn crankshaft to gain access to connecting rod caps (Figure 5, Item 2).
9. Remove connecting rod cap (Figure 5, Item 2) from cylinder block and set aside.
10. Push connecting rod (Figure 5, Item 1) up.
11. Remove piston (Figure 3, Item 4) and connecting rod (Figure 5, Item 1) from cylinder block.
12. Install connecting rod cap (Figure 5, Item 2) and two bolts (Figure 5, Item 3) on corresponding connecting rod to avoid mixing caps (Figure 5, Item 2).

**NOTE**

Repeat steps 5 through 12 above for three remaining connecting rods.

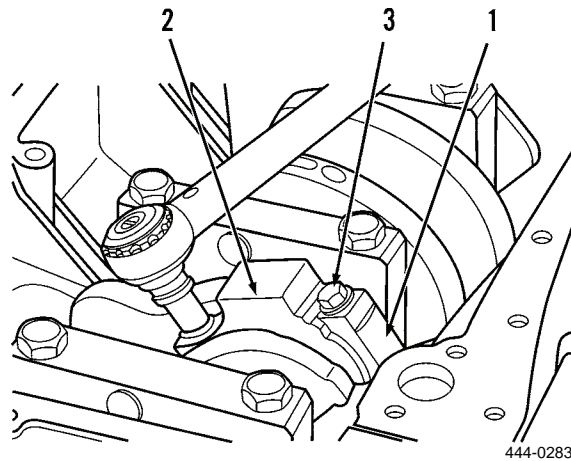

**Figure 5. Bearing Cap Installation.**

**END OF TASK**

**DISASSEMBLY**

1. Remove retaining ring (Figure 6, Item 8), piston pin (Figure 6, Item 9), and connecting rod (Figure 6, Item 1) from piston (Figure 6, Item 4).

**CAUTION**

Use piston ring expander to remove rings to avoid damaging piston and ring.

2. Use piston ring expander to remove top piston ring (Figure 6, Item 5) from piston (Figure 6, Item 4). Discard piston ring.
3. Use piston ring expander to remove middle piston ring (Figure 6, Item 6) from piston (Figure 6, Item 4). Discard piston ring.

**NOTE**

Oil ring is a two-piece assembly.

4. Remove oil ring (Figure 6, Item 7) from piston (Figure 6, Item 4). Discard oil ring.
5. Measure inside diameter of connecting rod (Figure 6, Item 1) for wear and out-of-round as shown (Figure 6). If inside diameter is more than 1.578 in. (40.08 mm), connecting rod bushing must be replaced.

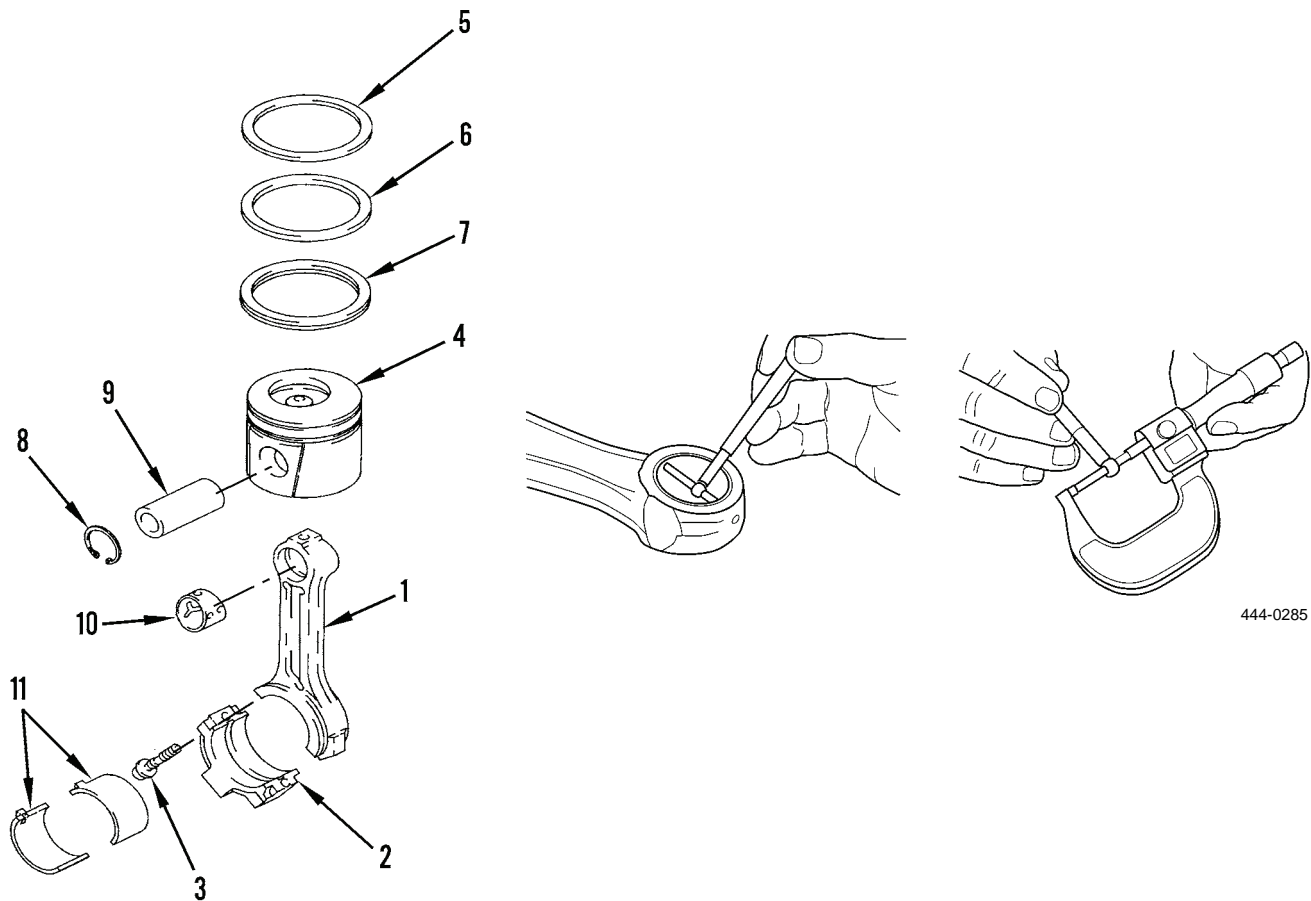

444-0276

444-0285

**Figure 6. Piston, Connecting Rod Assembly, and Measuring Inside Diameter of Connecting Rod.**

**END OF TASK**

## CLEANING



WARNING



- Solvent cleaning compound MIL-PRF-680 Type III is an environmentally compliant and low toxic material. However, it may be irritating to the eyes and skin. Use protective gloves and goggles. Use in well-ventilated areas. Keep away from open flames and other sources of ignition. Failure to do so may result in injury or death to personnel.
  - Particles blown by compressed air are hazardous. DO NOT exceed 15 PSI (103 kPa) nozzle pressure when drying parts with compressed air. DO NOT direct compressed air against human skin. Make sure air stream is directed away from user and other personnel in the area. To prevent injury, user must wear protective goggles or face shield. Failure to follow this warning may result in injury to personnel.
1. Use solvent cleaning compound to clean all parts. Dry thoroughly with moisture-free compressed air or clean rags.
  2. Remove carbon from piston (Figure 6, Item 4), taking care not to scratch piston.
  3. Clean piston ring groove. Break an old piston ring in half to clean grooves as shown (Figure 7).

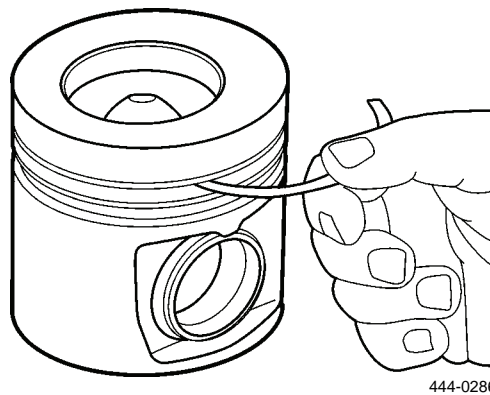

444-0286

**Figure 7. Cleaning Ring Groove with Old Piston Ring.**

4. Use small drill bit or fine wire to clean piston oil hole as shown (Figure 8).

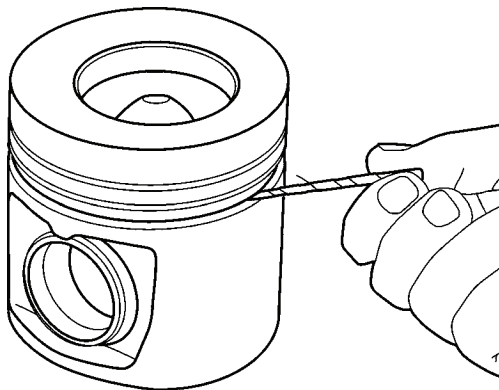

444-0287

**Figure 8. Cleaning Piston Oil Hole with Small Drill Bit.**

**END OF TASK**

**INSPECTION**

1. Inspect piston for cracks, damage, scoring, evidence of overheating, and damaged ring grooves as shown (Figure 9). If any of these conditions observed, replace piston.
2. Use bore gauge and measure pin bore diameter, turn gauge 90 degrees and measure pin bore diameter again as shown (Figure 9). Replace piston if pin bore diameter is greater than 1.576 in. (40.03 mm).
3. Use feeler gauge to measure oil ring side clearance as shown (Figure 9). If measurement exceeds 0.005 in. (0.13 mm), replace piston.

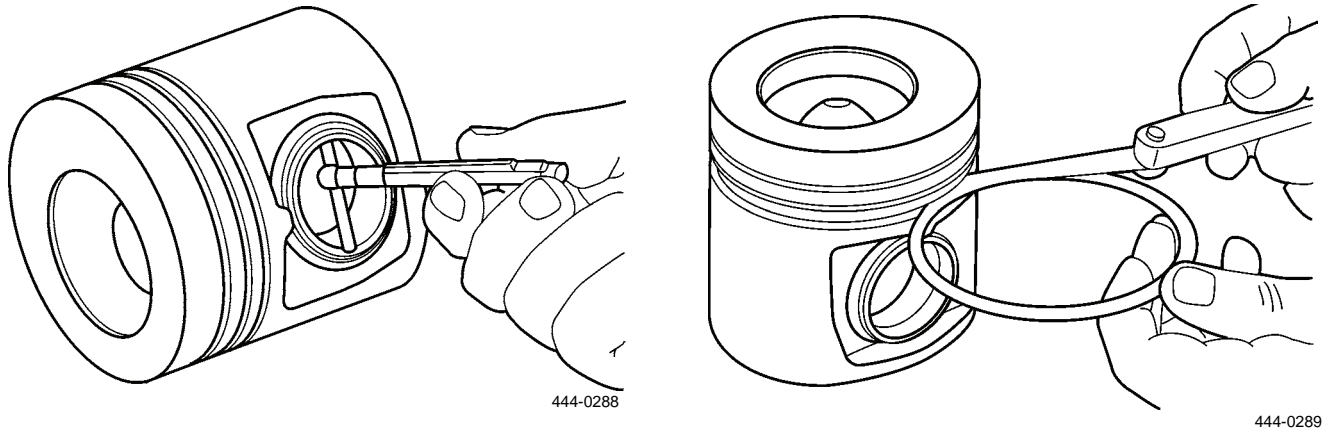

**Figure 9. Measuring Pin Bore Diameter and Oil Ring Side Clearance.**

4. Use feeler gauge to measure first and second piston ring side clearance. If measurement exceeds 0.006 in. (0.13 mm), replace piston.
5. Use micrometer to measure piston diameter across thrust face 0.5 in. (13 mm) from bottom of piston, perpendicular to piston pin holes, as shown (Figure 10). If piston diameter is less than 4.0088 in. (101.824 mm), replace piston.

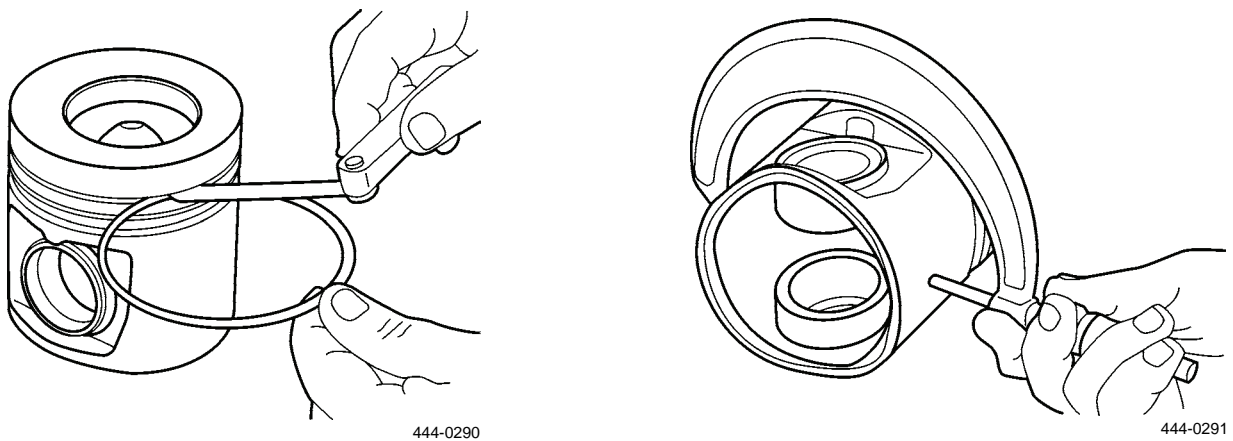

**Figure 10. Measuring First and Second Piston Side Clearance and Piston Diameter.**

**INSPECTION - CONTINUED**

6. Use micrometer to measure outside diameter of piston pin as shown (Figure 11). Replace if measurement is less than 1.5744 in. (39.990 mm).
7. Inspect retaining rings. Check for damage and loss of resiliency. Replace if damaged or resiliency is lost.

**NOTE**

Replace connecting rod as an assembly if side clearance check, performed in step 1 of *Removal* in this work package, exceeded 0.011 in. (0.28 mm).

8. Position pin bore of connecting rod on mandrel.

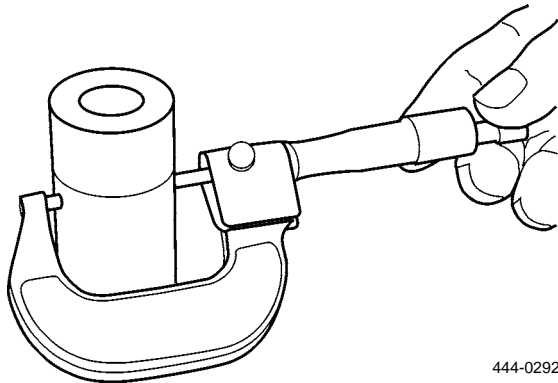

444-0292

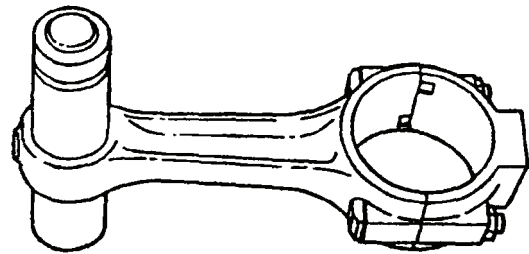

444-0293

**Figure 11. Measuring Outside Diameter of Piston Pin and Mandrel Installation.**

9. Knock out ring (thin) on mandrel over pin bore and match up angle surfaces as shown (Figure 12).
10. Install cup on mandrel and secure with cotter pin as shown (Figure 12).

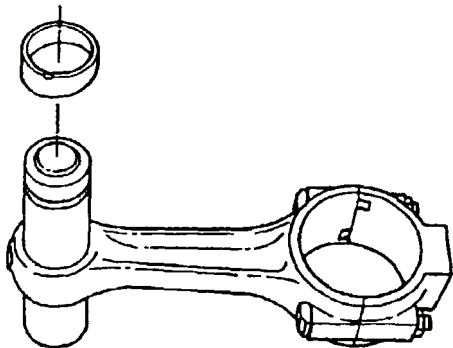

444-0294

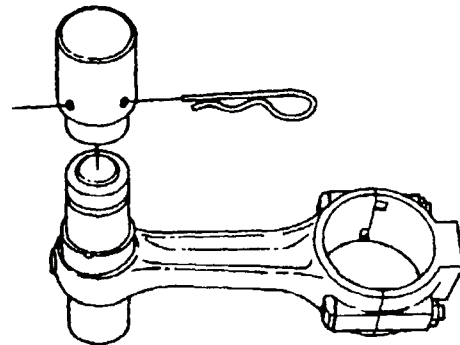

444-0295

**Figure 12. Knock Out Ring, Cup, and Cotter Pin Installation.**

**INSPECTION - CONTINUED**

11. Install mandrel in anvil so connecting rod matches angle of anvil as shown (Figure 13).
12. Press connecting rod bushing out of pin bore.

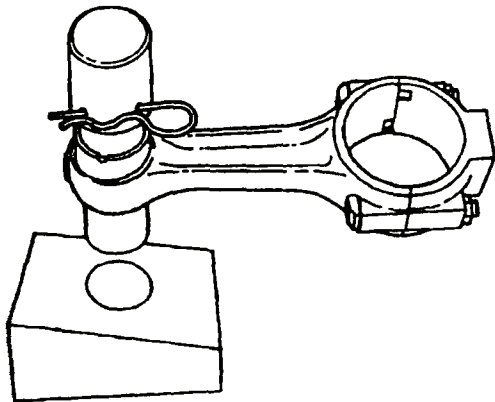

444-0296

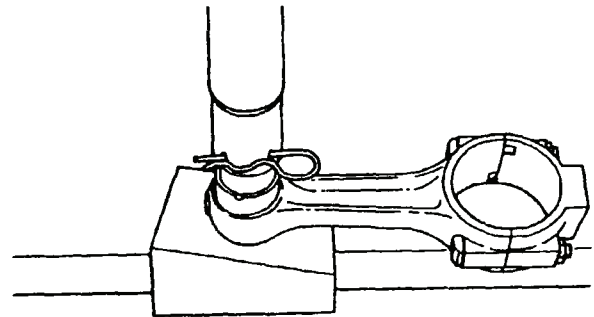

444-0297

**Figure 13. Installing Mandrel on Anvil.**

13. Remove cotter pin, remove cup rod, and slide connecting rod from mandrel as shown (Figure 14).
14. Use bore gauge, then measure bore gauge with micrometer from both sides of connecting rod as shown (Figure 14). Replace connecting rod if measurement is greater than 1.9296 in. (49.012 mm).

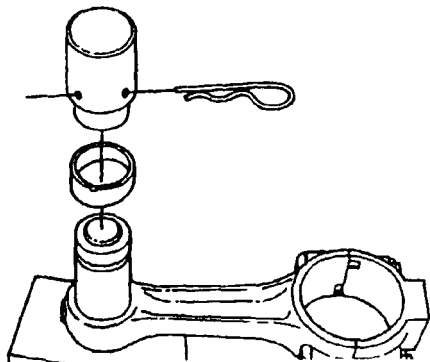

444-0298

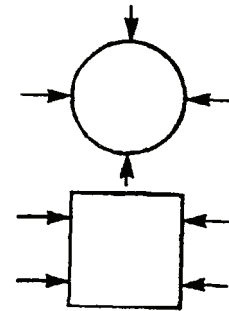
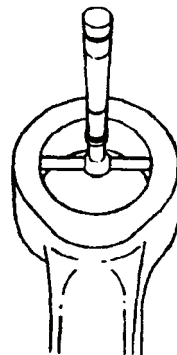

444-0299

**Figure 14. Measuring Bore Diameter of Connecting Rod.**

**INSPECTION - CONTINUED**

15. Position pin bore and connecting rod bushing in clean lubricating engine oil as shown (Figure 15).
16. Position connecting rod bushing on mandrel as shown (Figure 15).

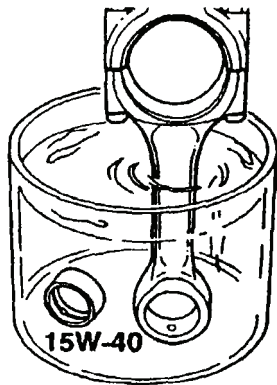

444-0300



444-0301

**Figure 15. Cleaning Connecting Rod and Bushing and Installing Bushing on Mandrel.**

17. Position knock out ring (thin) inside driver ring. Match angles and position angled side down. Align notch of knock out ring (thin) to pin of driver ring and slide onto mandrel as shown (Figure 16).
18. Install cup and secure with cotter pin as shown (Figure 16).



444-0302

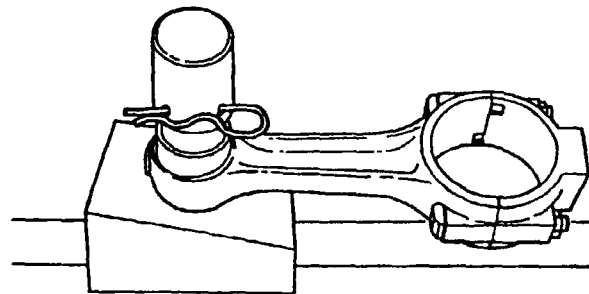

444-0303

**Figure 16. Installing Knock Out Ring, Cup, Cotter Pin, and Anvil on Connecting Rod and Bushing.**

**INSPECTION - CONTINUED**

19. Inspect connecting rod and connecting rod cap. Check for cracks, damage, wear, scoring, and pitting. If any of these conditions observed, replace as an assembly.
20. Measure piston rings. Place piston rings in cylinder and check end gap. Replace piston rings if end gap is more than 0.0317 in. (0.805 mm).

**NOTE**

Avoid mixing bearings, connecting rods, and connecting rod caps. Inspect one group at a time.

21. Remove connecting rod bolts. Check for damaged threads and distortion; if distorted or threads damaged replace part.
22. Remove bearings and check for scoring, pitting, flaking, cracking, or signs of overheating. Replace if any of these conditions observed.
23. Install connecting rod caps and bolts on corresponding connecting rods to avoid mixing caps.

**END OF TASK**



**ASSEMBLY**

1. Position connecting rod in piston. Numbered side of rod must face toward arrow side of piston.
2. Use hand pressure to install piston pin.
3. Use needle nose pliers to install two retaining rings.

**CAUTION**

Use piston ring expander to install piston rings to prevent damaging rings or piston.

4. Install piston oil ring in piston third groove as shown (Figure 17).
5. Install middle piston ring in piston second groove as shown (Figure 17).
6. Install top piston ring in piston first groove as shown (Figure 17).
7. Position piston rings. Rotate piston rings so ring end gaps are 120 degrees apart as shown (Figure 17).
8. Remove two connecting rod bolts and connecting rod cap from each connecting rod.



444-0306

**Figure 17. Piston Ring Assembly.**

9. Compress piston rings on piston as shown (Figure 18). If using strap-type compressor, make sure inside end of strap does not hook on ring gap or ring can break.

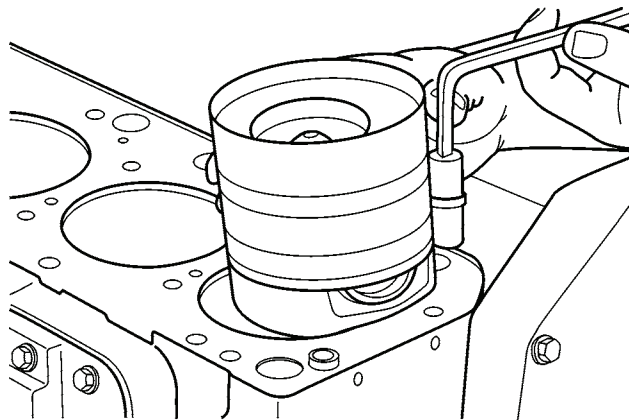

444-0307

**Figure 18. Compressing Piston Rings.****END OF TASK**

**INSTALLATION**

1. Use clean engine oil to lubricate cylinder bore as shown (Figure 19).
2. Install connecting rod journal at bottom dead center (BDC).
3. Lubricate threads and underside of connecting rod bolt threads and tighten bolts to 44 lb-ft (60 Nm) as shown (Figure 19).

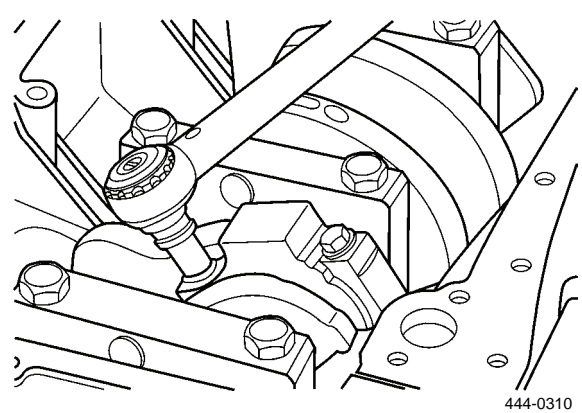
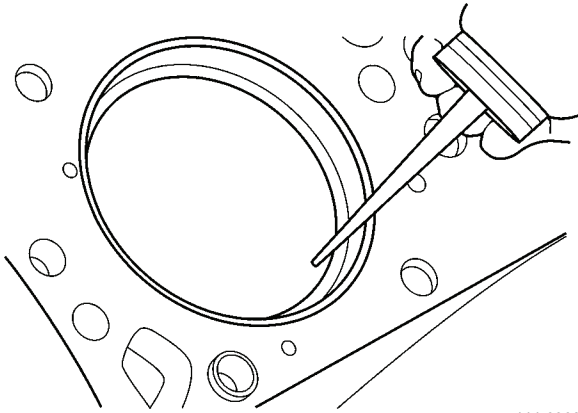
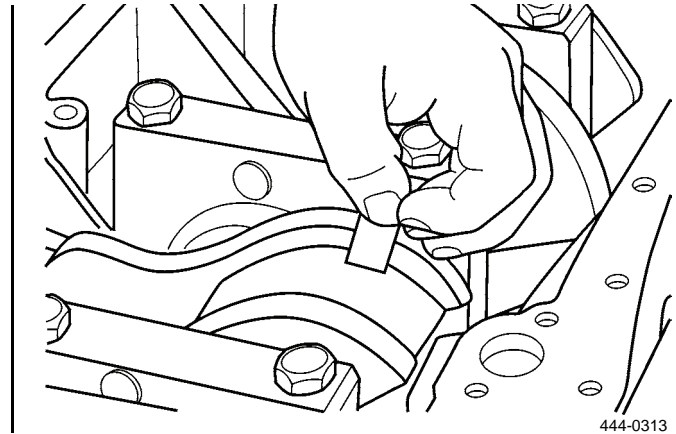
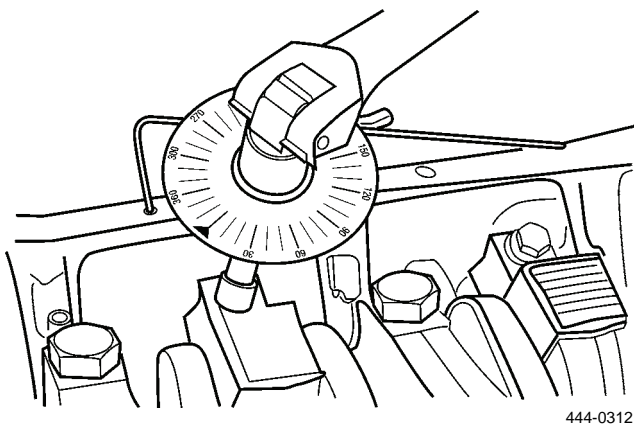

**Figure 19. Lubricating Cylinder Bore and Bearing Cap Installation.**

**INSTALLATION - CONTINUED****NOTE**

Make sure numbers stamped on rod and cap at parting line match oil cooler side of engine.

4. Install torque angle gauge and turn pointer to 60 degrees as shown (Figure 20). Tighten bolt until pointer is at 0 degrees.
5. Measure side clearance of connecting rod and crankshaft as shown (Figure 20). Side clearance must be between 0.0039 and 0.0123 in. (0.099 and 0.312 mm).



**Figure 20. Measuring Cap Bolt Torque and Connecting Rod Side Clearance.**

6. Check rod caps. Rotate crankshaft and make sure it rotates freely. If not, check installation of bearing liners and bearing liner size.

**CAUTION**

If connecting rod is not properly oriented with tang opposite of camshaft, it will contact the camshaft and lock engine.

7. Use dial indicator to check piston as shown (Figure 21). Piston protrusion must not be more than 0.0259 in. (0.658 mm) plus any amount of material removed during resurfacing.

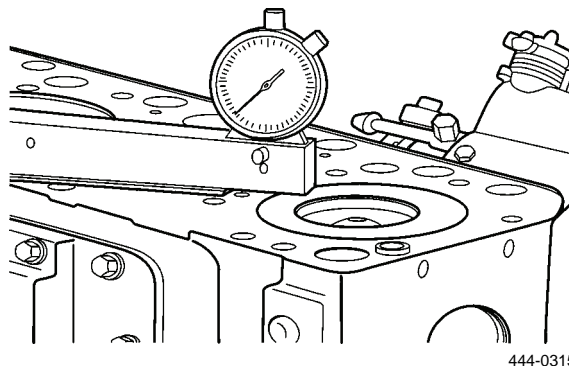

**Figure 21. Checking Piston Protrusion.**

**END OF TASK**

**END OF WORK PACKAGE**



---

## GENERAL SUPPORT MAINTENANCE INSTRUCTIONS

### CAMSHAFT AND BEARINGS MAINTENANCE (MODEL 207)

Removal, Disassembly, Cleaning, Inspection/Repair, Assembly, Installation

---

#### INITIAL SETUP

##### Maintenance Level

General Support

##### Tools and Special Tools

Tool kit, general mechanic's (Item 15, WP 0309)  
 Shop equipment, common no. 1 (Item 2, WP 0309)  
 Camshaft bushing tool kit (P/N A41103)  
 Clothespins  
 Dial indicator  
 Gear and bearing heater  
 Heat-resistant gloves  
 Metal rod, 1/2 in. dia. x 4 ft long  
 Micrometer, 0 to 5 in.  
 Wood dowels (8), 3/8-in. diameter x 12 in. long

##### Materials/Parts

Cleaning compound, solvent (Item 10, WP 0310)

##### Materials/Parts - Continued

Lubricating oil, OE/HDO-15/40 (Item 21, WP 0310)  
 Permatex (Item 30, WP 0310)  
 Rag, wiping (Item 26, WP 0310)  
 Lockwasher (2)

##### Equipment Condition

Exhaust manifold removed (WP 0055)  
 Water pump removed (WP 0086)  
 Fuel injector fittings disconnected (WP 0229)  
 Rocker arm assembly removed (WP 0224)  
 Tachometer drive removed (WP 0217)  
 Oil pan removed (WP 0226)  
 Timing gear cover removed (WP 0284)  
 Flywheel and flywheel housing removed (WP 0278)  
 Crankshaft removed (WP 0276)

---

**REMOVAL**

1. Remove eight push rods (Figure 1, Item 14) from top of cylinder head.

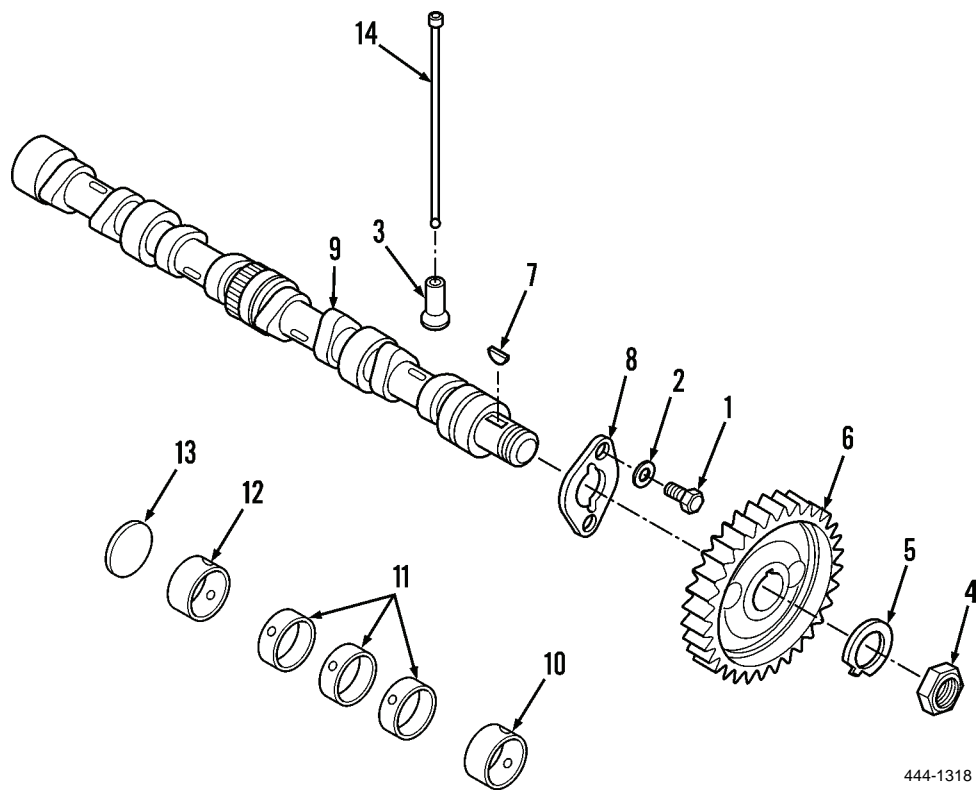
**Figure 1. Camshaft and Push Rod Assembly.**

2. Insert 3/8-in. diameter x 12-in. long wood dowels in push rod opening and push into valve tappets hole as shown (Figure 2).

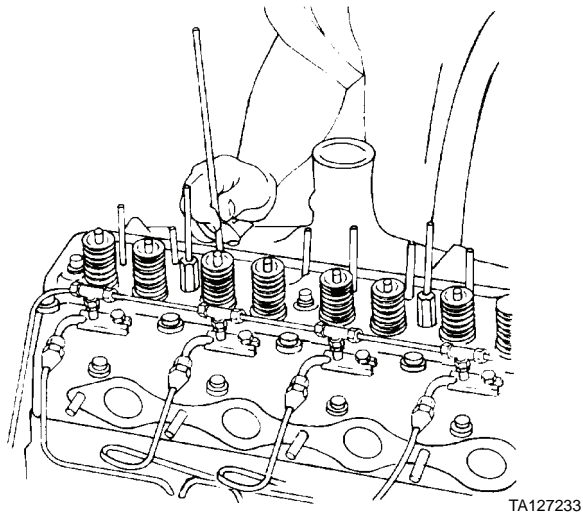
**Figure 2. Push Rod Removal.**

**REMOVAL - CONTINUED**

3. Raise eight valve tappets with dowels and retain in position with clothespins as shown (Figure 3).

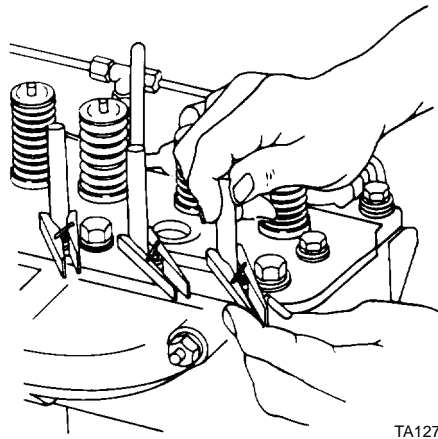

**Figure 3. Raising Retaining Push Rods.**

4. Remove two thrust plate bolts (Figure 1, Item 1) and lockwashers (Figure 1, Item 2) from camshaft thrust plate (Figure 1, Item 8). Align holes in camshaft gear (Figure 1, Item 6) with bolts (Figure 1, Item 1) by installing crankshaft pulley nut on crankshaft. Then, using socket and handle, turn crankshaft gear until holes and bolts are aligned. Discard lockwashers.

**CAUTION**

Be careful when removing camshaft so you do not damage bushings.

5. Remove camshaft (Figure 1, Item 9) and camshaft gear (Figure 1, Item 6).
6. Number valve tappets (Figure 1, Item 3) and their respective holes in cylinder block to ensure correct reinstallation.

**END OF TASK****DISASSEMBLY**

1. Bend tab of lock up, away from camshaft nut (Figure 1, Item 4), and remove camshaft nut and lock.
2. Use puller to remove camshaft gear (Figure 1, Item 6).
3. Remove key (Figure 1, Item 7) from camshaft (Figure 1, Item 9) slot.
4. Remove camshaft thrust plate (Figure 1, Item 8) from engine.

**END OF TASK**

**CLEANING****WARNING**

Solvent cleaning compound MIL-PRF-680 Type III is an environmentally compliant and low toxic material. However, it may be irritating to the eyes and skin. Use protective gloves and goggles. Use in well-ventilated areas. Keep away from open flames and other sources of ignition. Failure to do so may result in injury or death to personnel.

Use solvent cleaning compound to all other parts. Dry with moisture-free compressed air or clean rag.

**END OF TASK****INSPECTION/REPAIR**

1. Check camshaft surface for wear, damage, and scoring. If any of these conditions observed, replace camshaft.
2. Use micrometer to measure each bearing surface in four places. Measure front and rear surfaces again, 90 degrees from first measurement. If outer diameter of any bearing surface is less than 1.748 in. (44.40 mm), replace camshaft.
3. Inspect camshaft thrust plate. Replace if cracked, damaged, or worn.
4. Use micrometer to measure thickness of camshaft thrust plate. Replace if thickness is less than 0.147 in. (3.73 mm).
5. Inspect camshaft gear. Replace if cracked, or if teeth damaged or missing.
6. Inspect valve tappet. Replace if cracked, damaged, or worn.
7. Measure outer diameter stern. Replace if less than 0.5605 in. (14.237 mm).
8. Use bore gauge to measure inside diameter of valve tappet bores as shown (Figure 4). Replace cylinder block if greater than 0.5650 in. (14.351 mm).

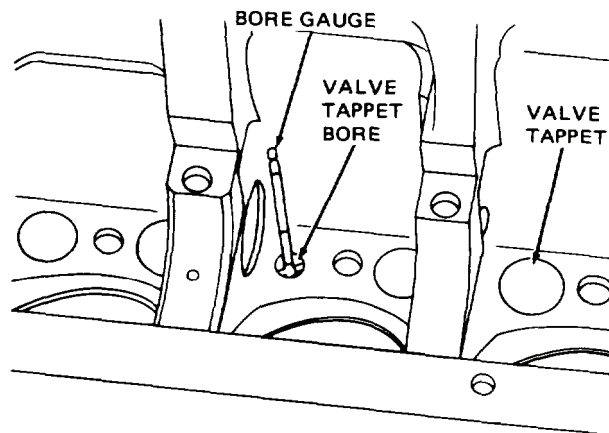

TA127235

**Figure 4. Measuring Inside Diameter of Valve Tappet Bores.**



**INSPECTION/REPAIR - CONTINUED**

9. Use bore gage and measure inside diameter of camshaft bushings in two places, 90 degrees apart. Replace if greater than 1.755 in. (44.58 mm).

**NOTE**

If camshaft bushings require replacement, perform steps 10 through 16, otherwise, proceed to *Assembly* in this work package.

10. Insert rod into block through camshaft bushings and tap cup plug out. Discard plug.
11. Insert bushing puller tool into cylinder block to remove intermediate and center camshaft bushings. Use open end adjustable wrench to turn nut and draw bushing out as shown (Figure 5).

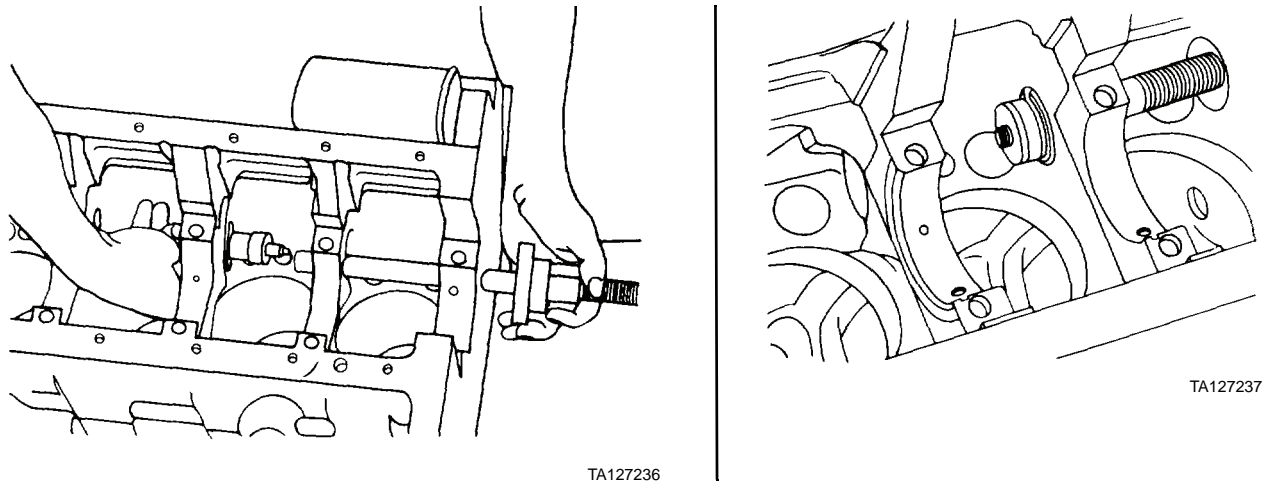

**Figure 5. Camshaft Bushing Removal.**

12. Use bushing puller tool to remove rear and front camshaft bushings.
13. Install intermediate and center camshaft bushing. Place 1/2-in. wide bushing on puller tool with offset oil hole in bushing oil hole aligned with oil hole in block as shown (Figure 6). Use open end adjustable wrench and pull bushing into block until flush with forward face of block.

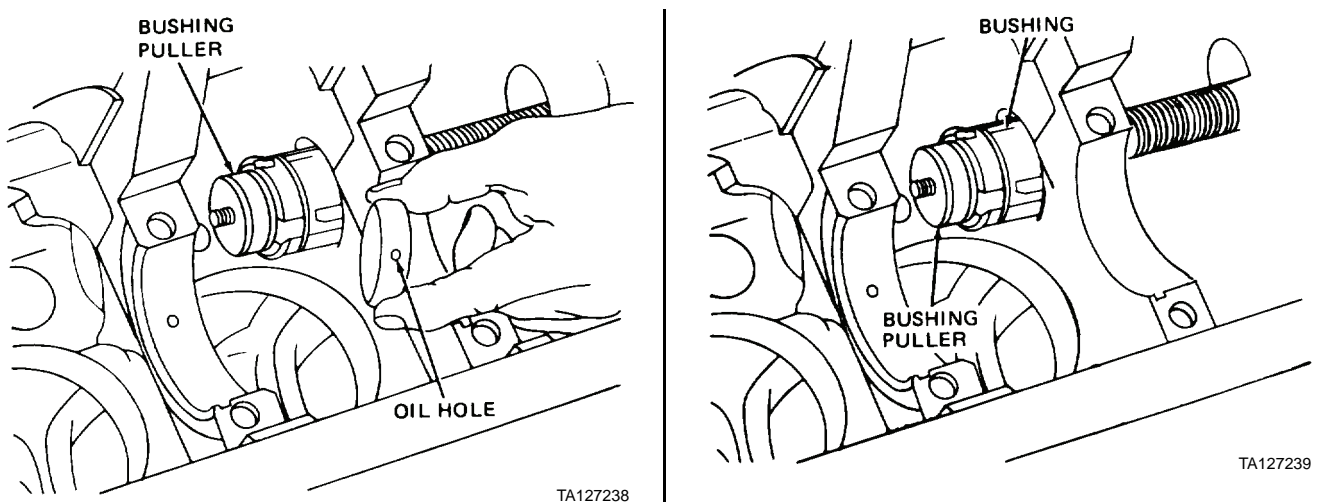

**Figure 6. Intermediate and Center Camshaft Bushing Installation.**

**INSPECTION/REPAIR - CONTINUED**

14. Install front camshaft bushing. Place 1-7/32-in. wide bushing on tool with offset oil holes towards front of block and oil holes towards front of block and oil hole (Figure 7, Item A) aligned with oil hole in block. Use open end adjustable wrench and pull bushing into block until 1/32 in. (0.79 mm) below front face of block.

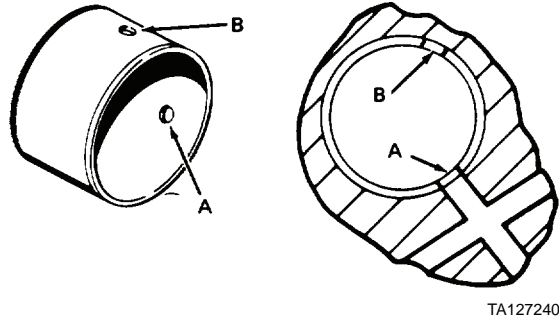

Figure 7. Front Camshaft Bushing.

15. Install rear camshaft bushing. Place 1-7/32-in. wide bushing on tool with offset oil holes towards front of block and aligned with oil holes in block. Use open end adjustable wrench and pull bushing into block until 5/16 in. (7.9 mm) below rear face of block.
16. Install plug cup in rear of cylinder block. Apply Permatex 2 to outer diameter and tap into position until it bottoms against seat.

**END OF TASK****ASSEMBLY**

1. Install camshaft thrust plate (Figure 8, Item 8) on camshaft (Figure 9, Item 9).
2. Install key (Figure 8, Item 7) in camshaft (Figure 8, Item 9) slot.

**WARNING**

Wear heat-resistant gloves when performing steps 3 through 6 to prevent burning your hands. If you burn your hands, obtain medical aid immediately.

3. Use gear and bearing heater to heat and install camshaft gear (Figure 8, Item 6). Make sure gear timing marks are outward.
4. Position lock (Figure 8, Item 5) on camshaft (Figure 8, Item 9).
5. Install camshaft nut (Figure 8, Item 4) on camshaft (Figure 8, Item 9). Tighten nut to 80 to 90 lb-ft (108 to 122 Nm).
6. Bend lock (Figure 8, Item 5) over one flat of camshaft nut (Figure 8, Item 4).

ASSEMBLY - CONTINUED

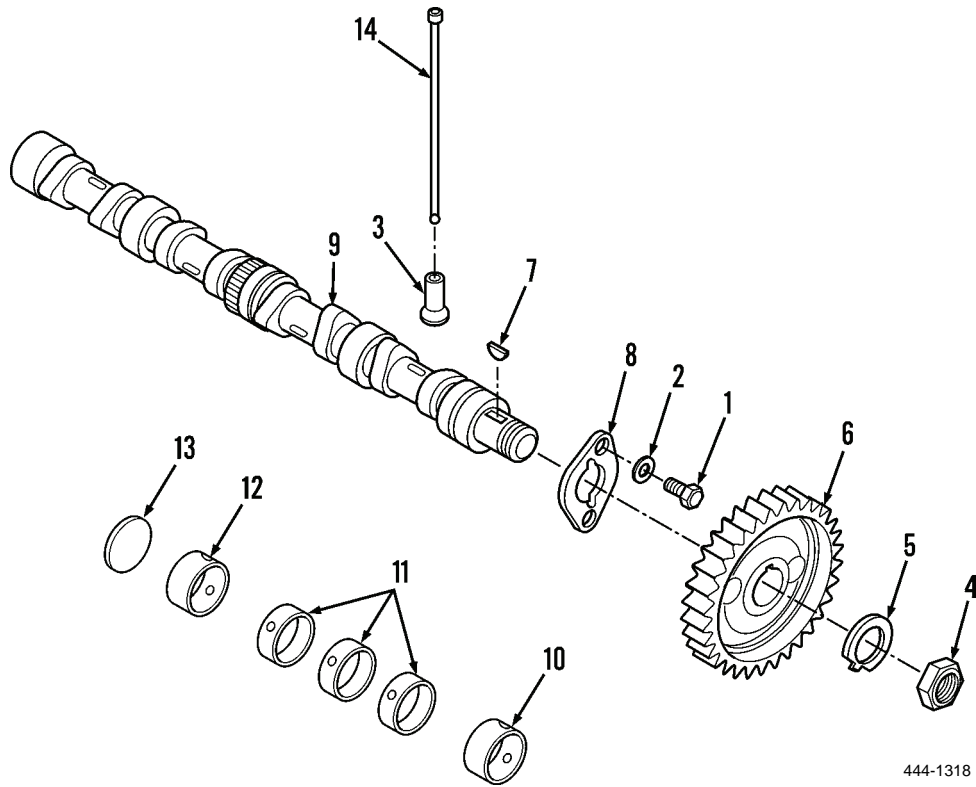

444-1318

Figure 8. Camshaft and Push Rod Assembly.

END OF TASK

**INSTALLATION****NOTE**

Install valve tappets in same locations as originally installed.

1. Use clean engine oil and insert eight wood dowels (3/8-in. diameter x 12-in. long) into push rod openings in top of cylinder head and push into stem of eight valve tappets. Lift dowels and valve tappets and retain with clothespins.
2. Use clean engine oil to lubricate camshaft thrust plate (Figure 9, Item 8), all bearing surfaces, and lifter cams. Align holes in camshaft gear (Figure 9, Item 6) with holes in thrust plate (Figure 9, Item 8).
3. Install two new lockwashers (Figure 9, Item 2) and thrust plate bolts (Figure 9, Item 1) on camshaft thrust plate (Figure 9, Item 8).
4. Align timing marks on camshaft gear as shown (Figure 9).

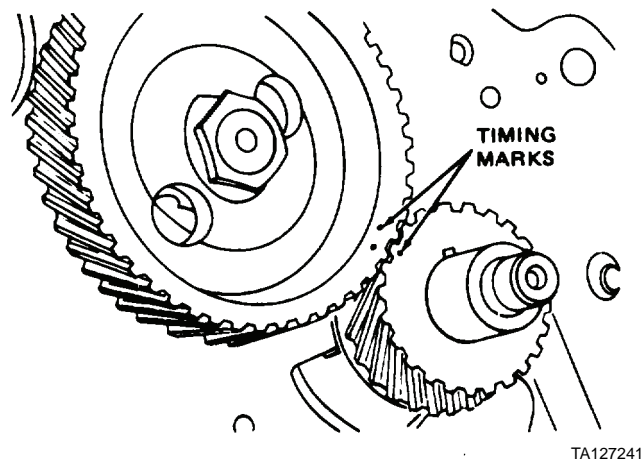

**Figure 9. Aligning Timing Marks.**

**INSTALLATION - CONTINUED**

5. Use dial indicator as shown to check backlash of camshaft gear (Figure 10). Backlash must be 0.002 to 0.006 in. (0.05 to 0.15 mm). If backlash exceeds 0.006 in. (0.15 mm), replace gear. Tighten two thrust plate bolts to 17 to 20 lb-ft (23 to 27 Nm).

**NOTE**

Excessive backlash may also be caused by worn camshaft bushings.

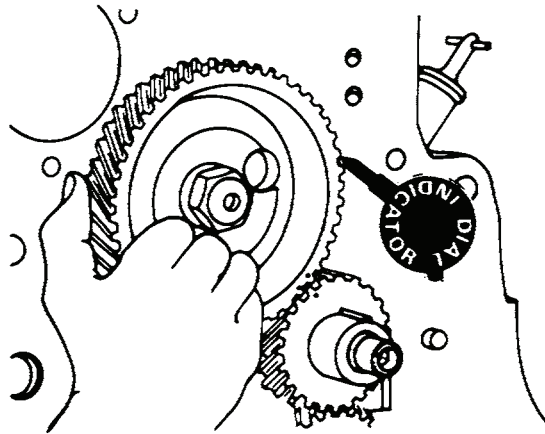

TA127242

**Figure 10. Measuring Backlash.**

6. Remove clothespins and dowels from cylinder head.
7. Install eight push rods on engine.

**END OF TASK****END OF WORK PACKAGE**



## GENERAL SUPPORT MAINTENANCE INSTRUCTIONS

### CAMSHAFT AND BEARINGS MAINTENANCE (MODEL 4-390)

Removal, Disassembly, Cleaning, Inspection/Repair, Bushing Removal, Bushing Installation, Assembly

#### INITIAL SETUP

##### Maintenance Level

General Support

##### Tools and Special Tools

Tool kit, general mechanic's (Item 15, WP 0309)  
 Shop equipment, common no. 1 (Item 2, WP 0309)  
 Bore gage, 0 to 5 in.  
 Bushing puller (CAS-14124)  
 Camshaft bushing tool kit (P/N A41103)  
 Clothespins  
 Dial indicator  
 Gear and bearing heater  
 Heat-resistant gloves  
 Metal rods, 1/2 in. dia. x 4 ft long  
 Micrometer, 0 to 5 in.  
 Pin (8 required)

##### Materials/Parts

Cleaning compound, solvent (Item 10, WP 0310)  
 Lubricating oil, OE/HDO-15/40 (Item 21, WP 0310)  
 Rag, wiping (Item 26, WP 0310)  
 Loctite 277  
 Gasket  
 Seal

##### Equipment Condition

Exhaust manifold removed (WP 0056)  
 Water pump removed (WP 0087)  
 Fuel injector fittings disconnected (WP 0232)  
 Rocker arm removed (WP 0225)  
 Oil pan removed (WP 0227)  
 Timing gear cover removed (WP 0285)  
 Flywheel and flywheel housing removed (WP 0279)  
 Crankshaft removed (WP 0277)

#### REMOVAL

1. Remove four lifter cover bolts and two breather cover nuts (if equipped) from right side of cylinder head as shown (Figure 1). Discard gasket and bolt seals.

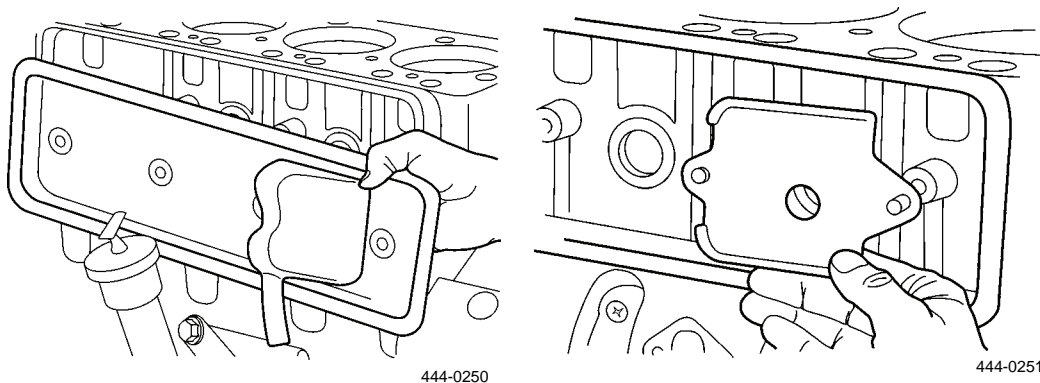
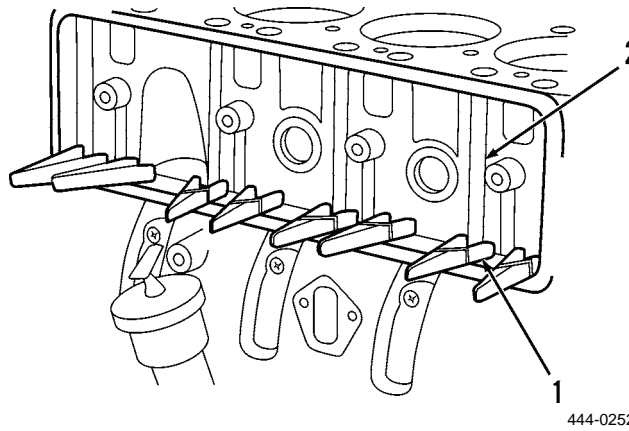

Figure 1. Lifter Cover Removal.

**REMOVAL - CONTINUED**

2. Raise eight valve tappets (Figure 2, Item 1) and push rods (Figure 3, Item 2) with dowels and retain in position with clothespins.



**Figure 2. Retaining Push Rods with Clothespins.**

3. Remove two thrust plate bolts (Figure 3, Item 2) from cylinder block. Align holes in camshaft gear with bolts by installing crankshaft pulley nut on crankshaft. Then, using socket and handle, turn crankshaft gear until holes and bolts are aligned.

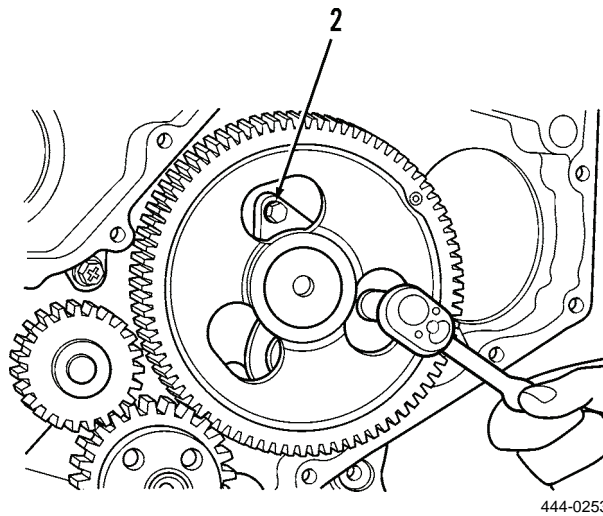

**Figure 3. Thrust Plate Bolt Removal.**



**REMOVAL - CONTINUED**

- Remove thrust plate (Figure 4, Item 4) from cylinder block.

**CAUTION**

Be careful when removing camshaft so you do not damage bushings (Figure 4, Items 6 and 7).

- Remove camshaft (Figure 4, Item 5) and camshaft gear (Figure 4, Item 8) from cylinder block.

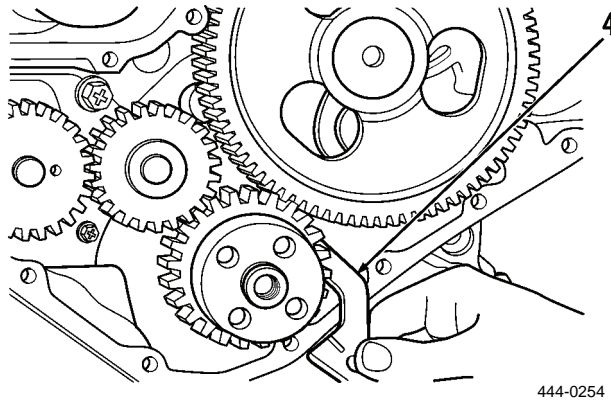

444-0254

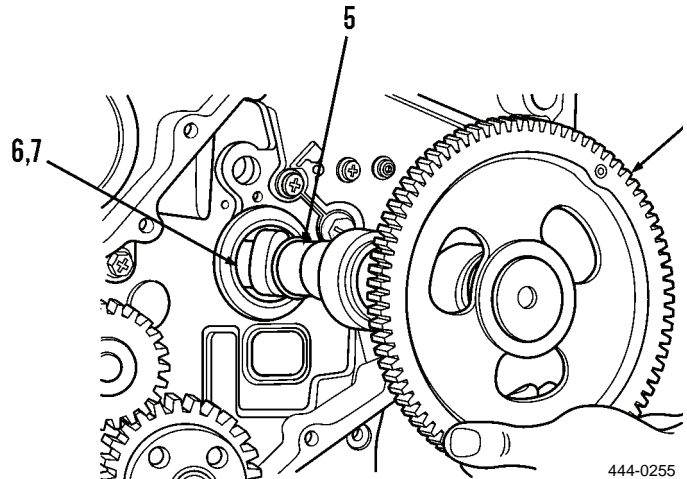

444-0255

**Figure 4. Camshaft and Gear Removal.**

**END OF TASK****DISASSEMBLY**

- Use press to remove camshaft gear (Figure 5, Item 8) from camshaft.
- Remove key (Figure 5, Item 9) from camshaft.

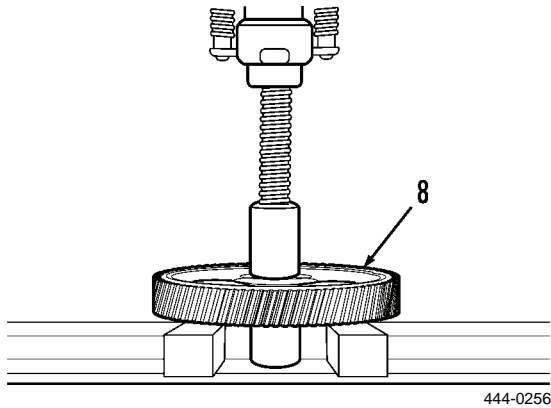

444-0256

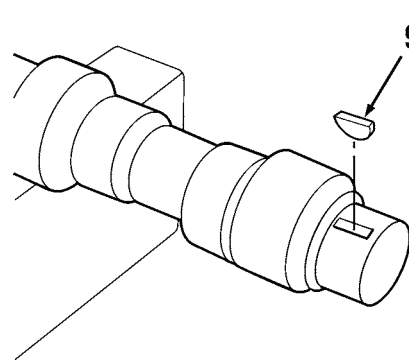

444-0257

**Figure 5. Remove Gear from Camshaft.**

**END OF TASK**

**CLEANING****WARNING****WARNING**

Solvent cleaning compound MIL-PRF-680 Type III is an environmentally compliant and low toxic material. However, it may be irritating to the eyes and skin. Use protective gloves and goggles. Use in well-ventilated areas. Keep away from open flames and other sources of ignition. Failure to do so may result in injury or death to personnel.

Use solvent cleaning compound to clean all parts. Dry thoroughly.

**END OF TASK****INSPECTION/REPAIR**

1. Inspect camshaft (Figure 6, Item 5). Check surfaces for wear, damage, and scoring. If any of these conditions observed, replace camshaft.
2. Use micrometer to measure front and rear of bearing surfaces as shown (Figure 6). Measure each bearing surface in four places. Measure front and rear surfaces again, 90 degrees from first measurement. If outer diameter of any bearing surface is less than 1.748 in. (44.44 mm), replace camshaft (Figure 6, Item 5).

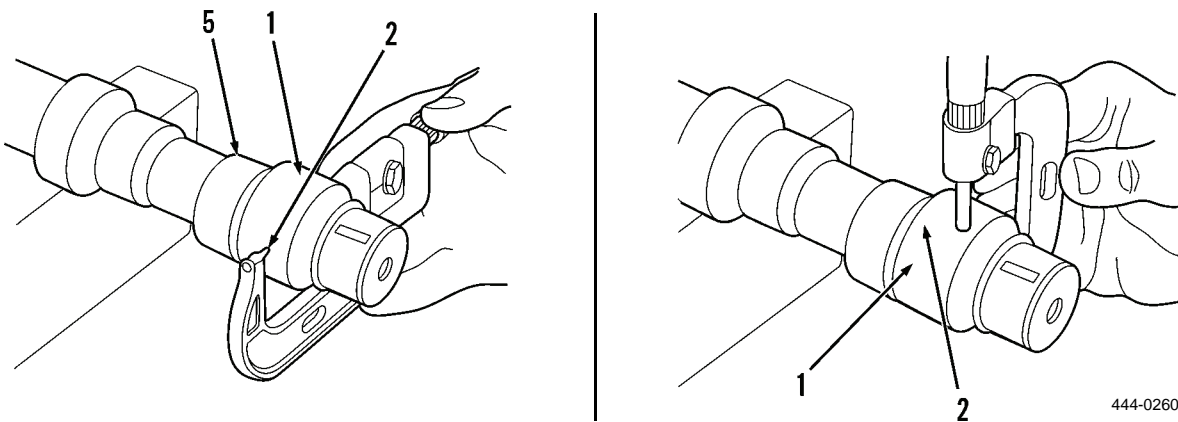

**Figure 6. Camshaft Bearing Surface Measurement.**

**INSPECTION/REPAIR - CONTINUED**

3. Inspect camshaft thrust plate. Replace if cracked, damaged, or worn.
4. Use micrometer to measure thickness. Replace if thickness is less than 0.147 in. (3.73 mm).
5. Measure camshaft bores in cylinder block as shown (Figure 7). Take two measurements at 90-degree angles. If intermediate or rear bores are more than 2.132 in. (54.15 mm), disassemble engine block and line bore bores. See specifications for machining dimensions.

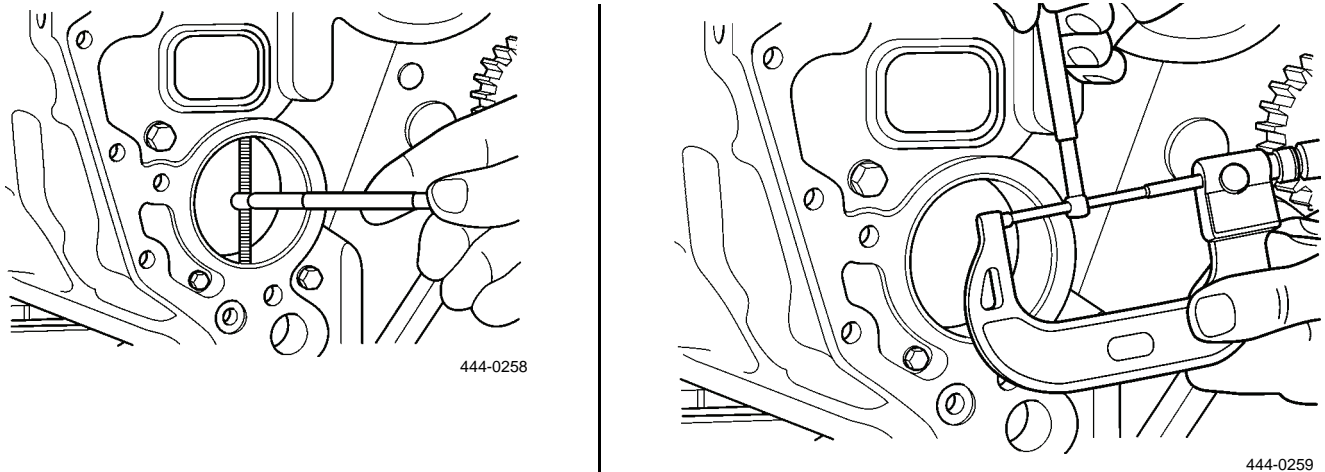
**Figure 7. Camshaft Bore Measurement.****NOTE**

The crankshaft and pistons have been removed for photographic purposes. These parts do not have to be removed to service the camshaft.

6. Measure bushing bore. If bushing diameter is more than 2.132 in. (54.15 mm), front camshaft bushing must be replaced.
7. Remove push rod and tappet (Figure 8, Item 1) from bottom of cylinder block.

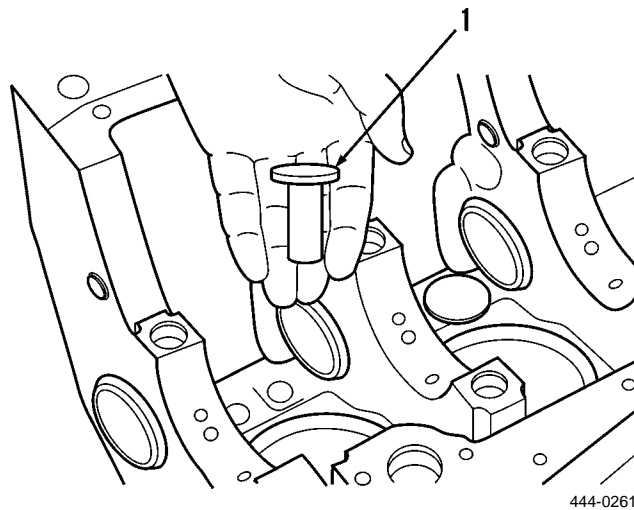
**Figure 8. Valve Tappet.****END OF TASK**

**BUSHING REMOVAL**

1. Measure tappet bores as shown (Figure 9). If diameter of tappet bore is more than 0.6311 in. (16.030 mm), engine block must be replaced.

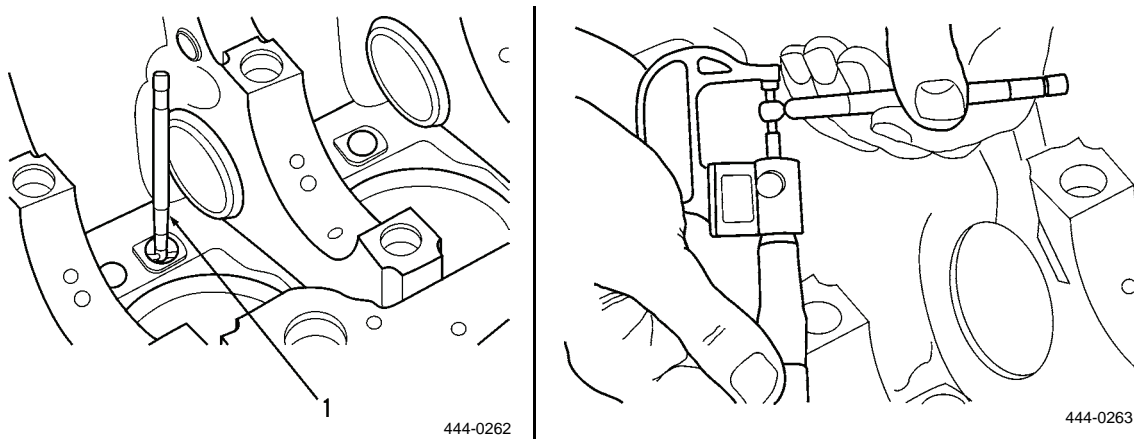
**Figure 9. Tappet Bore Measurement.**

2. Measure outside diameter (OD) of tappet stem as shown (Figure 10). Replace tappet stem if outside diameter is less than 0.6284 in. (15.961 mm).

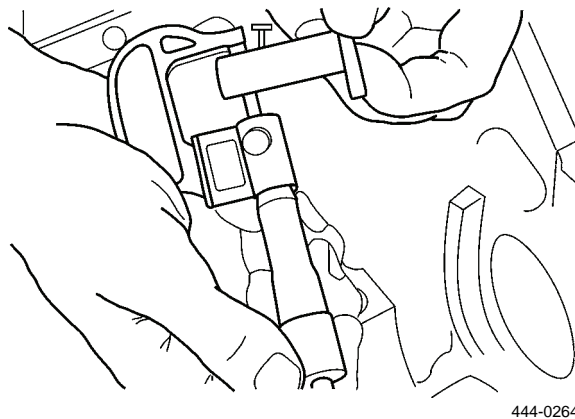
**Figure 10. Tappet Diameter Measurement.**

3. Measure camshaft bearing surface.
  - a. Use micrometer to measure front and rear of each bearing surface.
  - b. Each bearing surface must be measured in four positions. Measure front and rear bearing surfaces again, 90 degrees from first measurement.

**BUSHING REMOVAL - CONTINUED****NOTE**

Replace the camshaft if OD of any bearing surface is less than 2.1245 in. (53.962 mm).

4. Remove bushings (Figure 11, Items 6 and 7) from cylinder block. Put a bushing puller in engine block and pull bushing out of cylinder block. Use CAS- 14124 bushing puller. Clean oil holes in block.

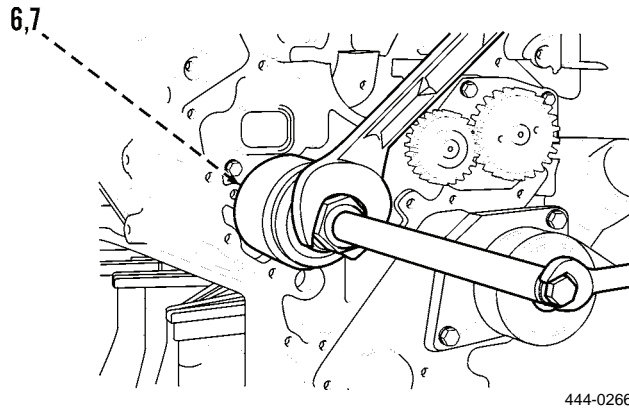
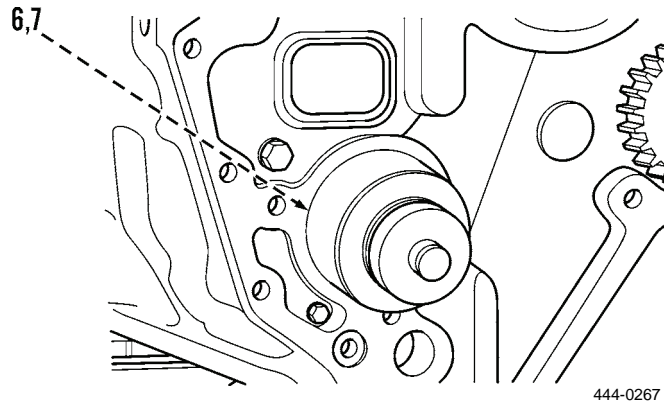

**Figure 11. Camshaft Bushing Removal.**

**END OF TASK**

**BUSHING INSTALLATION**

1. Install bushings (Figure 12, Items 6 and 7) in cylinder block. Install bushing on puller. Apply Loctite 277 to OD of bushing. Align oil holes. Pull bushing into cylinder block until it is even with housing. Remove any Loctite from oil holes after installation.



**Figure 12. Camshaft Bushing Installation.**

2. Use clean engine oil to lubricate tappets (Figure 13, Item 1) in bottom of cylinder block.

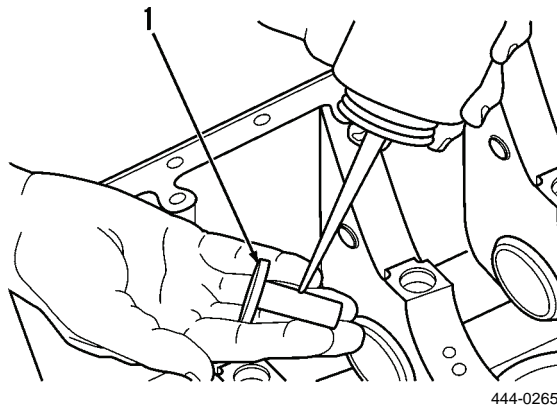

**Figure 13. Lubricating Tappets.**

**END OF TASK**

**ASSEMBLY**

**NOTE**

Heat the camshaft gear a minimum of 45 minutes at a temperature of 300°F (148°C). Use a bearing heater.

1. Install key on camshaft.
2. Install camshaft gear (Figure 14, Item 8) on camshaft with lock pin hole down as shown.
3. Use clean engine oil to lubricate bearing surface as shown (Figure 14).
4. Align timing marks (Figure 14, Item 1) between camshaft gear (Figure 14, Item 8) and crankshaft gear.
5. Install thrust plate (Figure 14, Item 4) on cylinder block.
6. Install thrust plate bolts (Figure 14, Item 3). Tighten bolts to 15 to 20 lb-ft (20 to 27 Nm).

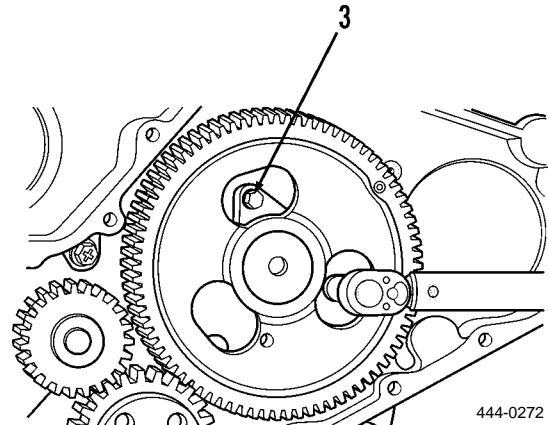
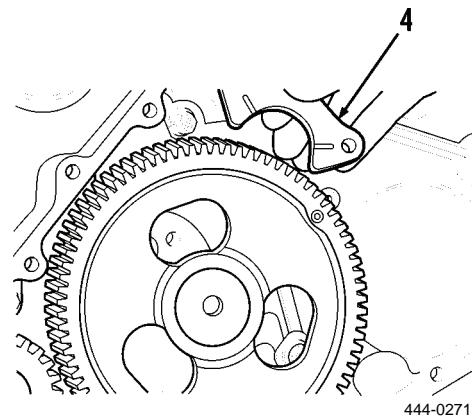
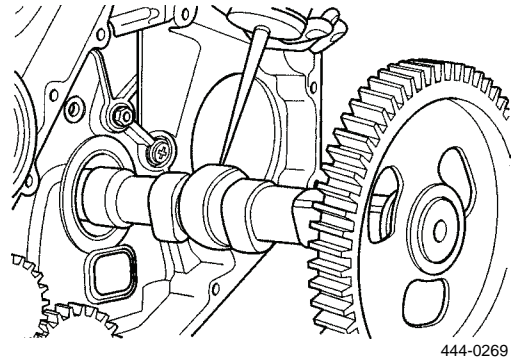
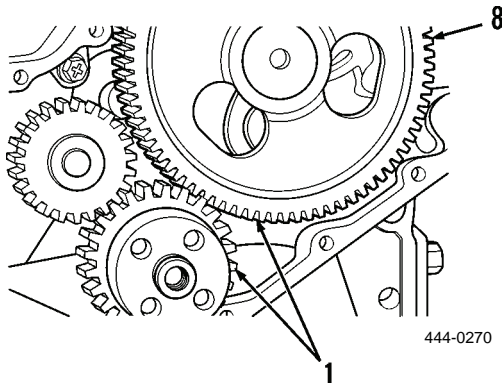
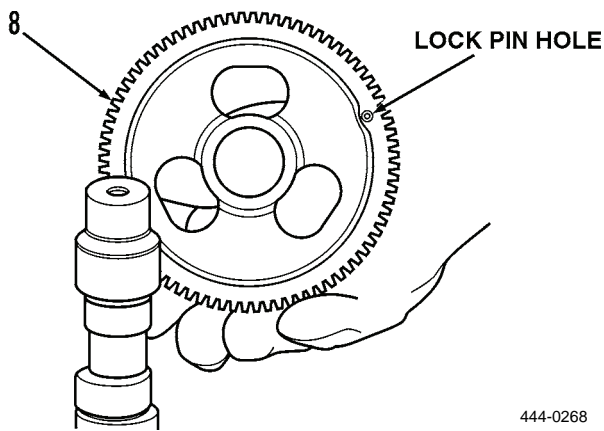

**Figure 14. Camshaft and Gear Installation.**

**ASSEMBLY - CONTINUED**

7. Check camshaft end clearance with a dial indicator as shown (Figure 15). End clearance must be 0.005 to 0.0185 in. (0.13 to 0.470 mm). If clearance is more than 0.0185 in. (0.470 mm), camshaft thrust plate must be replaced.

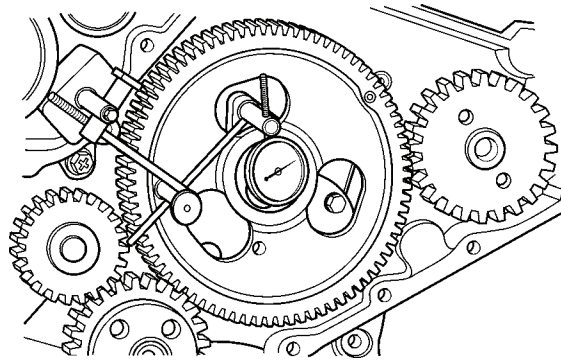

444-0273

**Figure 15. Camshaft End Clearance Measurement.**

8. Put a dial indicator on camshaft gear and check gear backlash between camshaft gear and crankshaft gear as shown (Figure 16). Gear backlash must be 0.003 to 0.013 in. (0.08 to 0.330 mm). If clearance is more than 0.018 in. (0.45 mm), gears must be replaced.

**NOTE**

Too much gear clearance can also be caused by worn camshaft bushing.

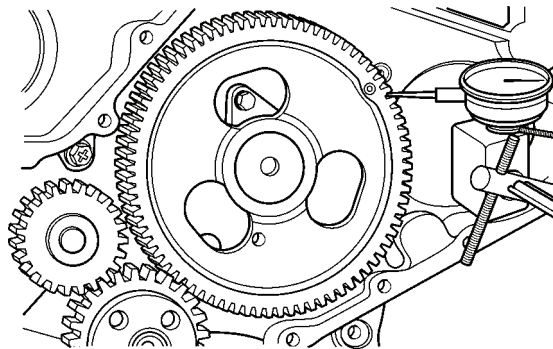

444-0274

**Figure 16. Camshaft Gear Backlash Measurement.**



**ASSEMBLY - CONTINUED**

9. Remove clothespins from right side of cylinder block.
10. Install breather cover, if equipped.
11. Install lifter cover, new gasket, four lifter cover bolts, and new bolt seals. Tighten bolts to 15 to 20 lb-ft (20 to 27 Nm) as shown (Figure 17).

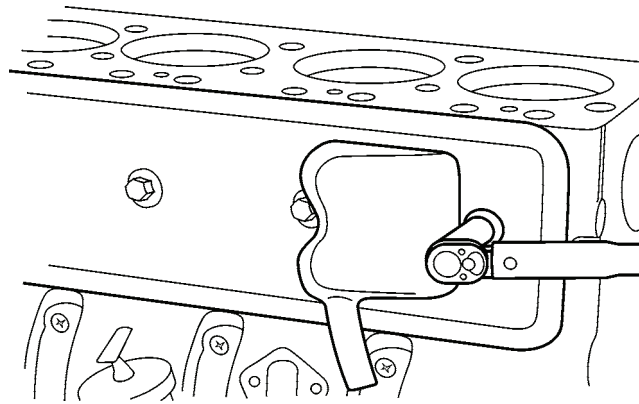

**Figure 17. Lifter Cover Installation.**

**END OF TASK**

**END OF WORK PACKAGE**



---

## GENERAL SUPPORT MAINTENANCE INSTRUCTIONS

### TIMING GEAR COVER REPLACEMENT (MODEL 207)

#### Removal, Cleaning, Inspection, Installation

---

#### INITIAL SETUP

##### Maintenance Level

General Support

##### Tools and Special Tools

Tool kit, general mechanic's (Item 15, WP 0309)  
Shop equipment, common no. 1 (Item 2, WP 0309)  
Bore gage, 0 to 5 in.  
Dial indicator (P/N CAS 1066A)  
Micrometer, 0 to 5 in.  
Universal gear puller (NSN 5120-00-378-4293)

##### Materials/Parts

Cleaning compound, solvent (Item 10, WP 0310)

##### Materials/Parts - Continued

Lubricating oil, OE/HDO-15/40 (Item 21, WP 0310)  
Permatex (Item 30, WP 0310)  
Rag, wiping (Item 26, WP 0310)  
Sleeve, 2-in. diameter  
Lockwasher (2)  
Timing gear cover gasket  
Timing gear cover plate gasket

##### Equipment Condition

Water pump removed (WP 0086)  
Fuel injection pump removed (WP 0233)  
Oil pan removed (WP 0226)

---

**REMOVAL**

1. Remove seven capscrews (Figure 1, Item 1) from cover plate (Figure 1, Item 3).
2. Remove two nuts (Figure 1, Item 2) from cover plate (Figure 1, Item 3).
3. Remove cover plate (Figure 1, Item 3) and cover plate gasket (Figure 1, Item 4) from timing gear cover (Figure 1, Item 27). Discard cover plate gasket.
4. Remove nut (Figure 1, Item 5) from crankshaft pulley (Figure 1, Item 6).
5. Use gear puller to remove crankshaft pulley (Figure 1, Item 6).
6. Use punch and hammer to straighten tabs of lock plate (Figure 1, Item 8), releasing capscrews (Figure 1, Item 7).
7. Remove two capscrews (Figure 1, Item 7), lock plate (Figure 1, Item 8), thrust plate (Figure 1, Item 9), and shim(s) (Figure 1, Item 10).
8. Remove idler gear (Figure 1, Item 11) and bushing (Figure 1, Item 12) from idler gear hub (Figure 1, Item 13).

**CAUTION**

Do not damage aluminum wall of timing gear cover while separating oil seal in step 9.

9. Use 2-in. diameter sleeve to drive oil seal (Figure 1, Item 14) deeper onto crankshaft.
10. Remove two capscrews (Figure 1, Item 15) and lockwashers (Figure 1, Item 16) from timing gear cover (Figure 1, Item 27). Discard lockwashers.
11. Remove capscrew (Figure 1, Item 24) and washer (Figure 1, Item 25).
12. Remove capscrew (Figure 1, Item 23) and washer (Figure 1, Item 25).
13. Remove capscrew (Figure 1, Item 22) and two washers (Figure 1, Items 25 and 26).
14. Remove three nuts (Figure 1, Item 17), washers (Figure 1, Item 18), capscrews (Figure 1, Item 19), and washers (Figure 1, Item 20).
15. Remove three capscrews (Figure 1, Item 21) and washers (Figure 1, Item 25).
16. Remove timing gear cover (Figure 1, Item 27) with idler gear hub (Figure 1, Item 13). Take care not to damage aluminum timing gear cover.
17. Remove and discard gasket (Figure 1, Item 30).

**NOTE**

Idler gear hub is press fitted in aluminum. Do not perform step unless inspection requires replacement.

18. Remove idler gear hub (Figure 1, Item 13) from rear (engine side) of timing gear cover (Figure 1, Item 27).
19. Remove two studs (Figure 1, Item 28) from timing gear cover (Figure 1, Item 27).
20. Remove three studs (Figure 1, Item 29) from timing gear cover (Figure 1, Item 27).
21. Remove and discard oil seal (Figure 1, Item 14) from crankshaft.
22. Remove oil slinger (Figure 1, Item 31) from crankshaft.

REMOVAL - CONTINUED

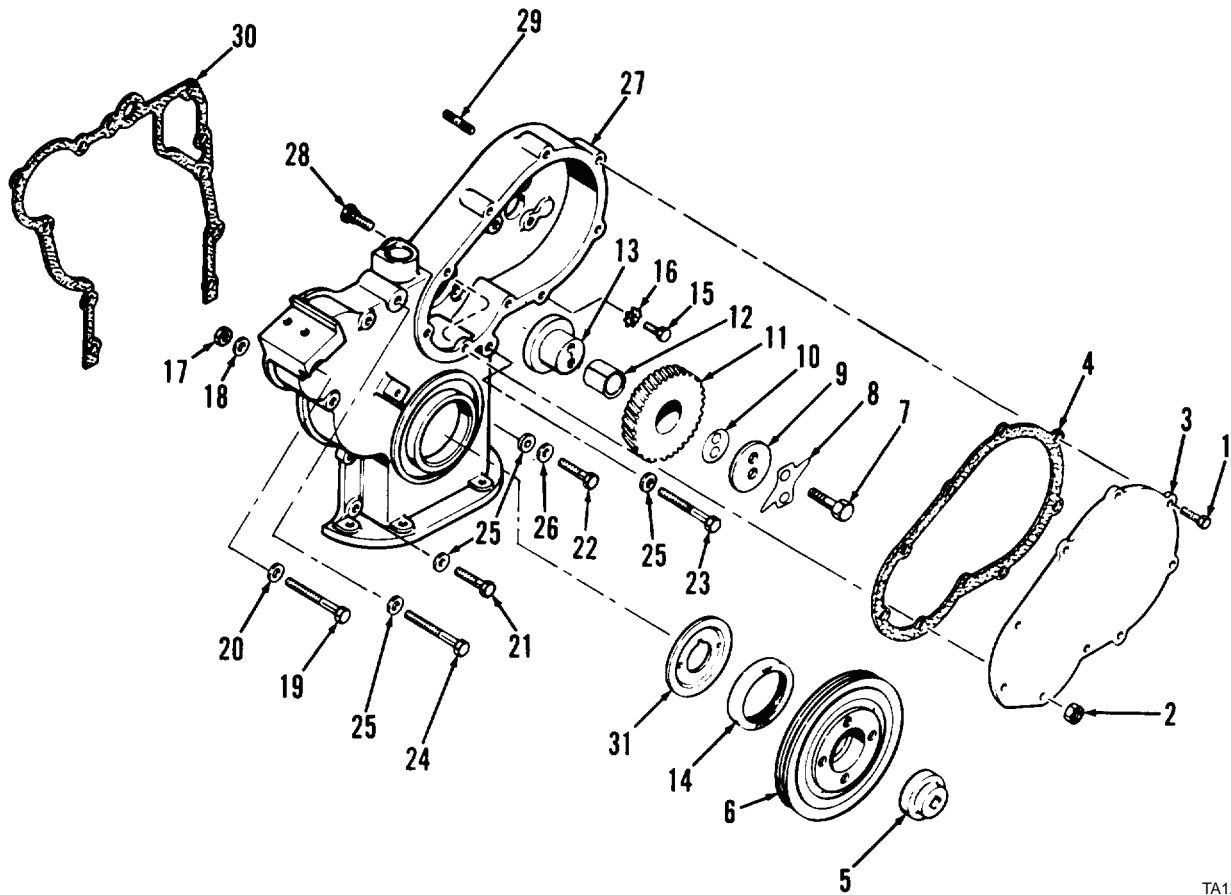

TA127196

Figure 1. Timing Gear and Cover Assembly.

END OF TASK

CLEANING



- Solvent cleaning compound MIL-PRF-680 Type III is an environmentally compliant and low toxic material. However, it may be irritating to the eyes and skin. Use protective gloves and goggles. Use in well-ventilated areas. Keep away from open flames and other sources of ignition. Failure to do so may result in injury or death to personnel.
- Particles blown by compressed air are hazardous. DO NOT exceed 15 PSI (103 kPa) nozzle pressure when drying parts with compressed air. DO NOT direct compressed air against human skin. Make sure air stream is directed away from user and other personnel in the area. To prevent injury, user must wear protective goggles or face shield. Failure to follow this warning may result in injury to personnel.

Use solvent cleaning compound to clean all other parts. Dry with moisture-free compressed air or clean rag.

END OF TASK

## INSPECTION

1. Inspect idler gear and bushing for damage, distortion, and missing or broken teeth. Check gear teeth for pitting. If any of these conditions are observed, replace gear and bushing as an assembly. Use bore gage and measure inside diameter of idler gear bushing. Measure bore gage using micrometer. If bushing inside diameter is more than 1.377 in. (34.98 mm), replace gear and bushing as an assembly.
2. Inspect idler gear hub for cracks, pitting, and distortion. Replace if any of these conditions observed. Use micrometer and measure outside diameter of hub shaft. Diameter must be not less than 1.3740 in. (34.90 mm); replace part if diameter is less than dimension.
3. Inspect timing gear cover for cracks and distortion; replace if cracked or distorted. Check threads on studs for damage; if threads are damaged or studs bent, replace studs. Replace stud by driving it out of cover using soft hammer, insert new stud in cover, install 3/8-16 nut, and tighten nut to draw stud into mounting hole. Remove nut. Replace stud by unscrewing it and installing new stud.
4. Inspect all other parts. Check for cracks, damage, and distortion; replace part if any of these conditions observed.

## END OF TASK

## INSTALLATION

1. Install oil slinger on end of crankshaft with cupped surface toward crankshaft gear. Align notch on oil slinger with keyway on crankshaft.
2. Apply Permatex 2 to both sides of cylinder block from lower mounting hole downwards as shown (Figure 2).

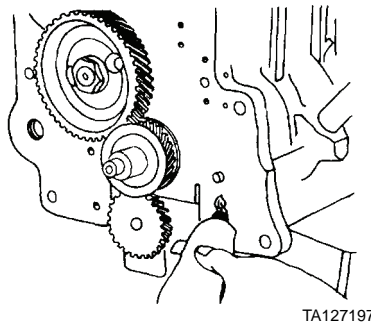
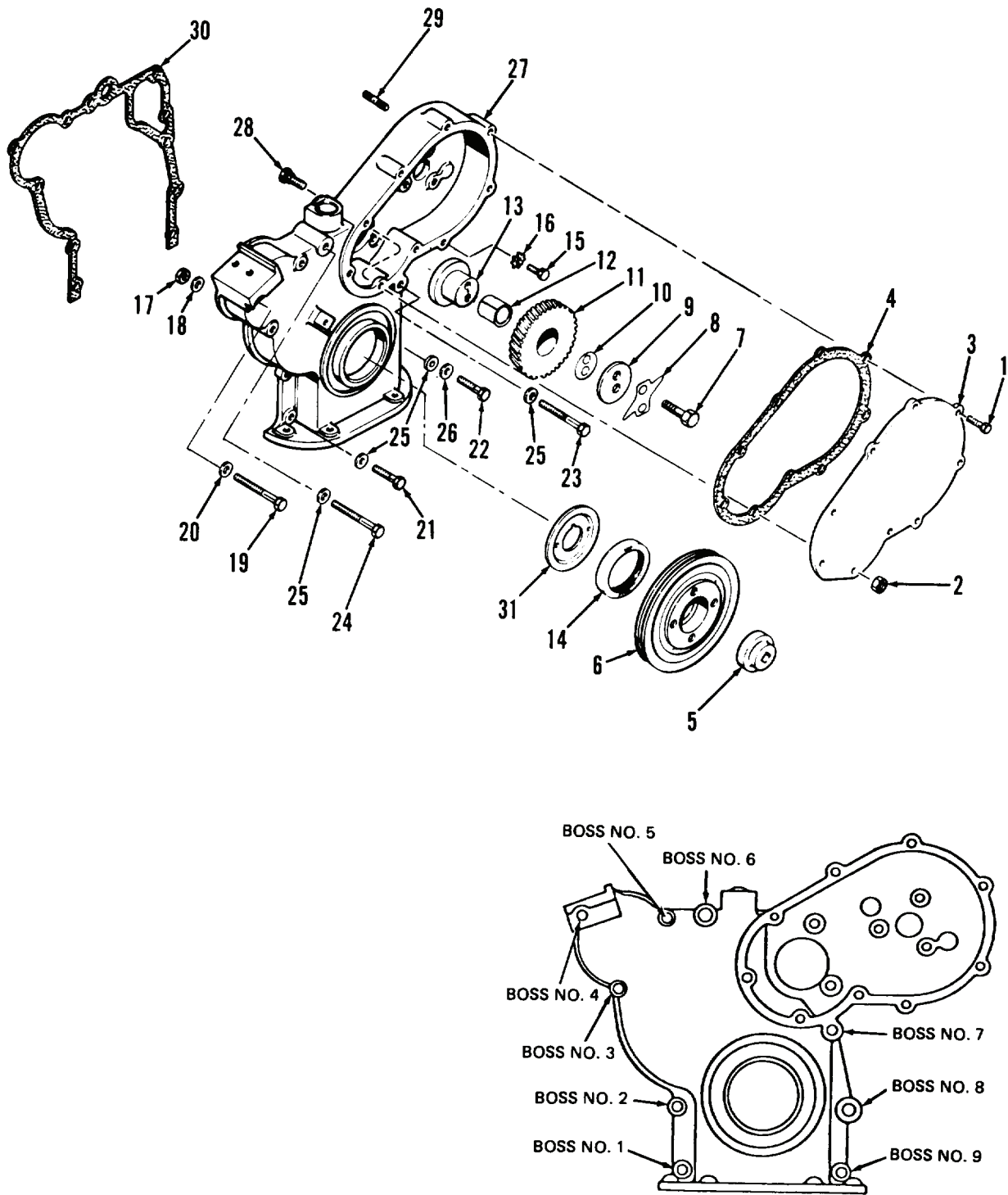

**Figure 2. Applying Permatex 2 to Cylinder Block.**

3. Install new gasket (Figure 4, Item 30) on cylinder block and apply Permatex 2 to open face of gasket from lower mounting hole downwards.
4. Position timing gear cover (Figure 4, Item 27) on cylinder block and install three capscrews (Figure 4, Item 21) and washers (Figure 4, Item 25). Install 1-1/4-in. long capscrews in cover bosses 1, 2, and 9. Tighten capscrews to 25 to 30 lb-ft (34 to 41 Nm).
5. Install three capscrews (Figure 4, Item 19), washers (Figure 4, Item 20), washers (Figure 4, Item 18), and nuts (Figure 4, Item 17) on timing gear cover (Figure 4, Item 27). Install 3-1/4-in. long capscrew in cover bosses 3, 4, and 5. Tighten capscrews to 25 to 30 lb-ft (34 to 41 Nm).
6. Install capscrew (Figure 4, Item 22) and washers (Figure 4, Items 25 and 26) on timing gear cover (Figure 4, Item 27). Install 1-1/2-in. long capscrew in cover boss 8. Tighten capscrew to 25 to 30 lb-ft (34 to 41 Nm).
7. Install capscrew (Figure 4, Item 23) and washer (Figure 4, Item 25) on timing gear cover (Figure 4, Item 27). Install 2-3/4-in. long capscrew in cover boss 7. Tighten capscrew to 25 to 30 lb-ft (34 to 41 Nm).
8. Install capscrew (Figure 4, Item 24) and washer (Figure 4, Item 25) on timing gear cover (Figure 4, Item 27). Install 3-in. long capscrew in cover boss 6. Tighten capscrew to 25 to 30 lb-ft (34 to 41 Nm).
9. Install two capscrews (Figure 4, Item 15) and new lockwashers (Figure 4, Item 16) on timing gear cover (Figure 4, Item 27). Tighten capscrews to 25 to 30 lb-ft (34 to 41 Nm).

**INSTALLATION - CONTINUED**

10. Install new gasket (Figure 4, Item 30) on cylinder block. Cut off any protruding gasket from bottom of cylinder block. Gasket must be flush with cylinder block.



TA127196

**Figure 3. Timing Gear and Cover Assembly.**

**INSTALLATION - CONTINUED**

11. Install idler gear hub on timing gear cover. Align hub oil groove in cylinder block as shown (Figure 4).

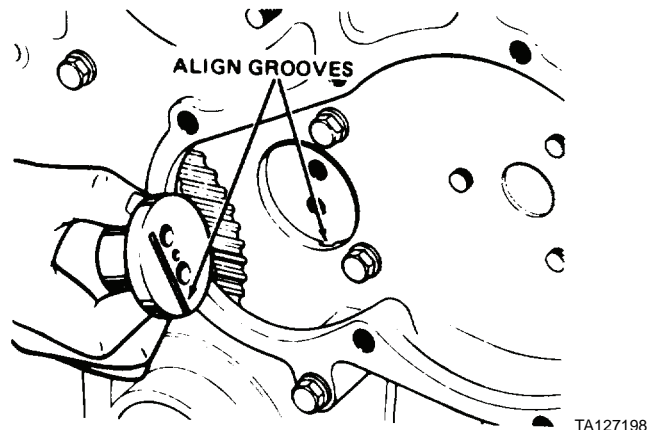

**Figure 4. Aligning Oil Grooves Between Idler Gear Hub and Cylinder Block.**

12. Use clean engine oil to lubricate idler gear and bushing and install on idler gear hub. Face large hub side toward cylinder block as shown (Figure 5).

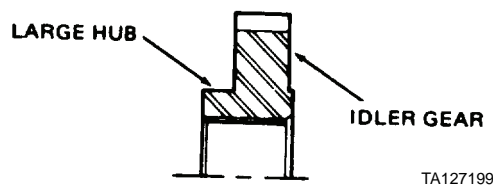

**Figure 5. Idler Gear Installation.**

13. Install capscrew (Figure 7, Item 7) on lock plate (Figure 7, Item 8).
14. Install thrust plate (Figure 7, Item 9) on lock plate (Figure 7, Item 8).
15. Install enough shims (Figure 7, Item 10) on thrust plate to maintain a running clearance of 0.003 in. (0.08 mm) between thrust plate (Figure 7, Item 9) and idler gear (Figure 7, Item 11).
16. Install lock plate (Figure 7, Item 8), thrust plate (Figure 7, Item 9), shim(s) (Figure 7, Item 10), and capscrew (Figure 7, Item 7) on idler gear hub (Figure 7, Item 13).
17. Align lock plate (Figure 7, Item 8) with engine at top dead center (TDC) and No. 1 cylinder on compression stroke; lock plate point must be aligned with timing mark on camshaft gear as shown (Figure 6).

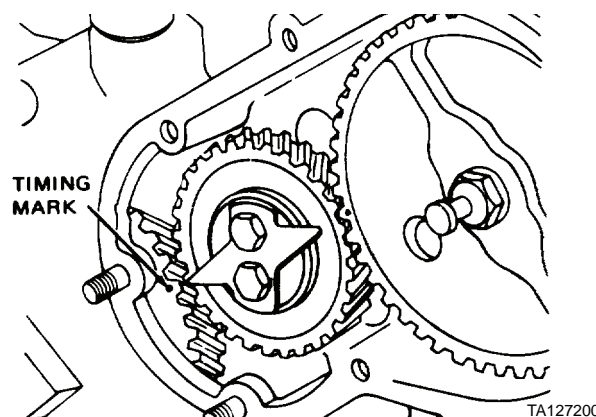

**Figure 6. Aligning Timing Marks.**



INSTALLATION - CONTINUED

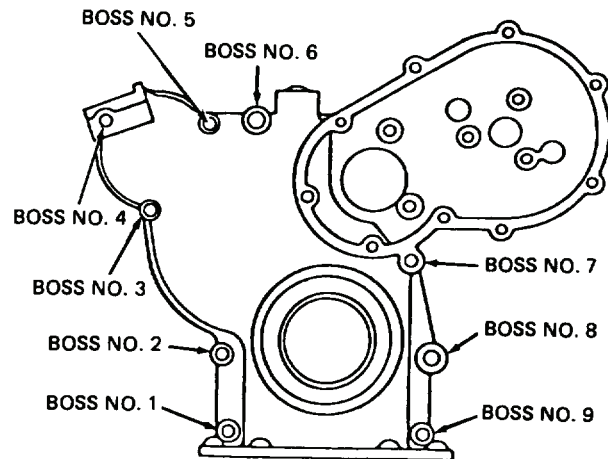
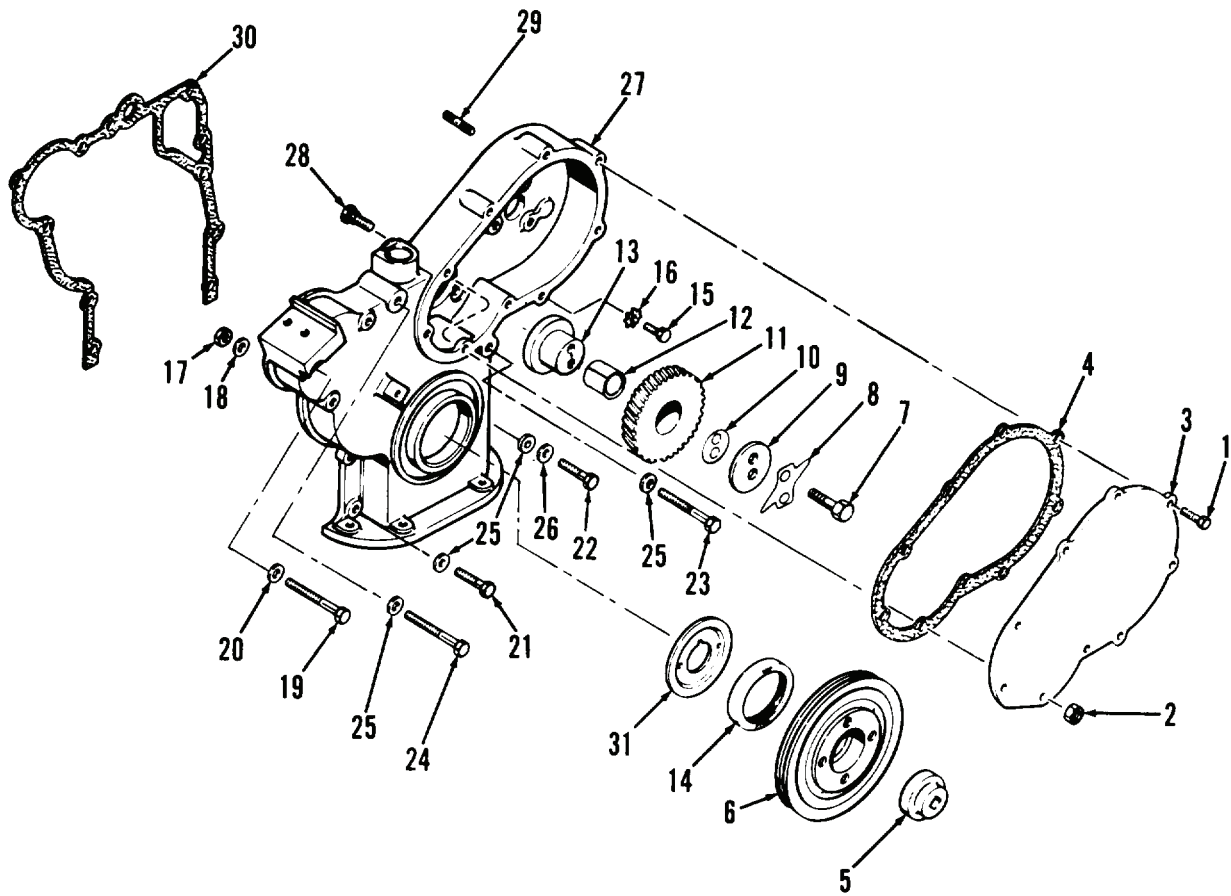

TA127196

Figure 7. Timing Gear and Cover Assembly.

**INSTALLATION - CONTINUED**

18. Tighten two capscrews (Figure 8, Item 7) to 35 to 42 lb-ft (47 to 57 Nm).
19. Use feeler gauge to check running clearance between thrust plate and idler gear as shown (Figure 8). Clearance must be 0.003 in. (0.08 mm). If clearance is not 0.003 in. (0.08 mm), remove two capscrews, shim(s), thrust plate, and lock plate as an assembly. Remove and measure thickness of shim(s) using micrometer. Add or remove shim(s) as necessary to obtain correct clearance. Install shim(s), thrust plate, lock plate, and two capscrews as an assembly. Tighten capscrews to 35 to 42 lb-ft (47 to 57 Nm).

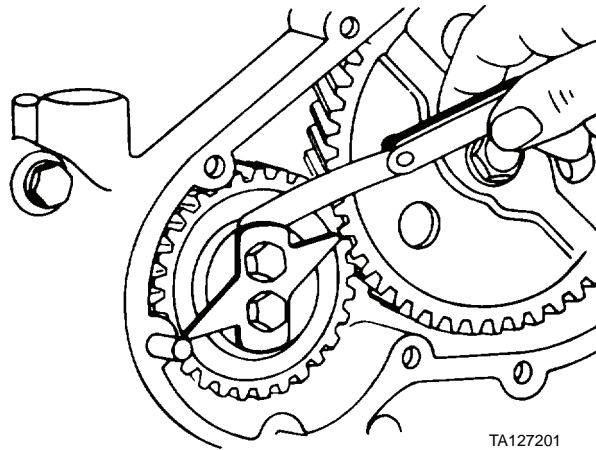
**Figure 8. Running Clearance Check.**

20. Bend tabs on lock plate to lock two capscrews.
21. Use screwdriver to hold camshaft gear.
22. Use dial indicator to check backlash of idler gear as shown (Figure 9). Backlash should not exceed 0.006 in. (0.15 mm); if backlash exceeds this dimension, replace gear.

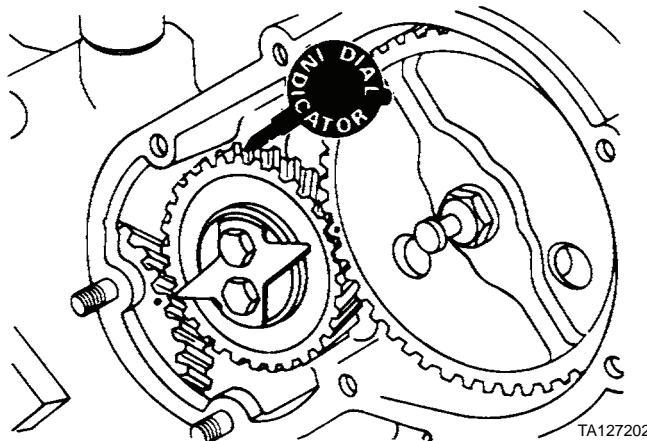
**Figure 9. Idler Gear Backlash Measurement.**

**INSTALLATION - CONTINUED**

23. Use depth gauge to install oil seal on crankshaft with seal lip inward to depth shown (Figure 10). After installation, use clean engine oil to lubricate oil seal.

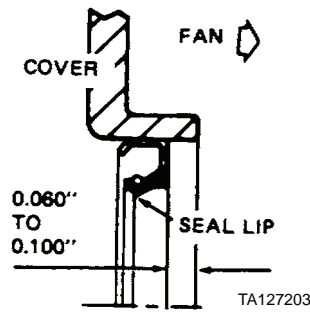

**Figure 10. Crankshaft Seal Installation.**

24. Use lubricating oil to lubricate shaft of crankshaft pulley (Figure 11, Item 6) and install on crankshaft.
25. Install nut (Figure 11, Item 5) on crankshaft and tighten to 125 to 135 lb-ft (169 to 183 Nm).
26. Install new cover plate gasket (Figure 11, Item 4) on timing gear cover (Figure 11, Item 27).
27. Position cover plate (Figure 11, Item 3) and install two nuts (Figure 11, Item 2) and seven capscrews (Figure 11, Item 1). Tighten nuts to 25 to 30 lb-ft (34 to 41 Nm).

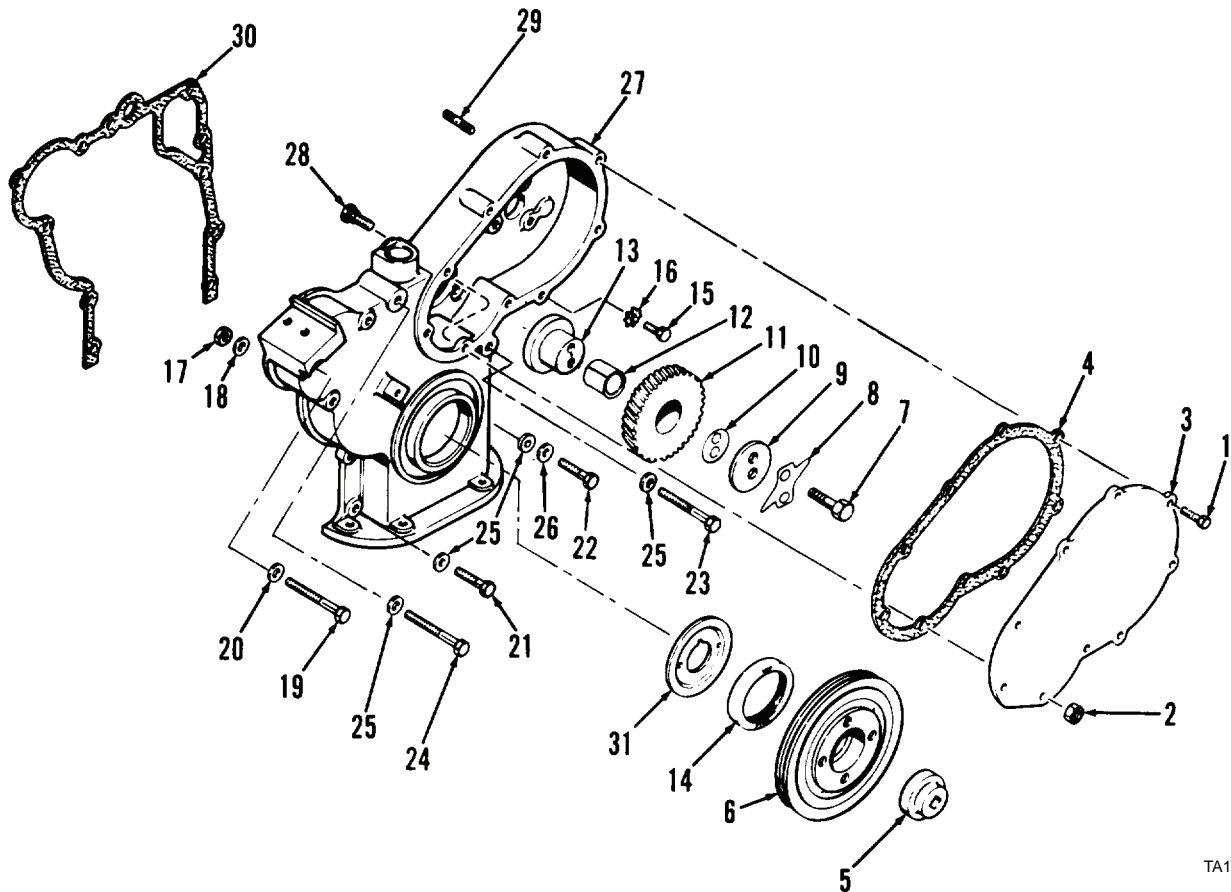

**Figure 11. Timing Gear and Cover Assembly.**

TA127196

**END OF TASK  
END OF WORK PACKAGE**



---

## GENERAL SUPPORT MAINTENANCE INSTRUCTIONS

### TIMING GEAR COVER REPLACEMENT (MODEL 4-390)

#### Removal, Cleaning, Inspection, Installation

---

#### INITIAL SETUP

##### Maintenance Level

General Support

##### Tools and Special Tools

Tool kit, general mechanic's (Item 15, WP 0309)

Bore gauge, 0 to 5 in.

Dial indicator (P/N CAS-10066A)

Feeler gage

Micrometer, 0 to 5 in.

Sleeve, 2-in. diameter

Torque wrench (NSN 5120-00-221-7983)

Universal gear puller (NSN 2150-00-378-4298)

##### Materials/Parts

Cleaning compound, solvent (Item 10, WP 0310)

Lubricating oil, OE/HDO-15/40 (Item 21, WP 0310)

Permatex (Item 30, WP 0310)

##### Materials/Parts - Continued

Rag, wiping (Item 26, WP 0310)

Bolt seal

Gasket (2)

O-ring

Seal

##### References

WP 0275

WP 0277

WP 0283

##### Equipment Condition

Radiator removed (WP 0083)

Water pump and pulley removed (WP 0087)

Fuel injection pump removed (WP 0234)

Oil pan removed (WP 0227)

---

**REMOVAL**

1. Remove four bolts (Figure 1, Item 2) from front timing gear cover (Figure 1, Item 1).
2. Remove hub (Figure 1, Item 3) and crankshaft pulley (Figure 1, Item 4) from front timing gear cover (Figure 1, Item 1).
3. Remove crankshaft seal (Figure 1, Item 5) (WP 0275).
4. Remove 22 mounting bolts (Figure 1, Item 6) and bolt seal (Figure 1, Item 7) from front timing gear cover (Figure 1, Item 1). Discard bolt seal.
5. Remove front timing gear cover (Figure 1, Item 1) from front of engine block.
6. Remove fuel injection pump drive gear (WP 0234).
7. Remove camshaft and gear (WP 0283).
8. Remove rear timing gear cover (Figure 1, Item 8) and gasket (Figure 1, Item 9) from front of engine block. Discard gasket.
9. Remove two bolts (Figure 1, Item 10), access cover (Figure 1, Item 11), and gasket (Figure 1, Item 12) from rear timing gear cover (Figure 1, Item 8). Discard gasket.
10. Remove retaining ring (Figure 1, Item 13), O-ring (Figure 1, Item 14), pin (Figure 1, Item 15), two screws (Figure 1, Item 16), bracket (Figure 1, Item 17), and seal (Figure 1, Item 18) from rear timing gear cover (Figure 1, Item 8). Discard O-ring and seal.

**END OF TASK****CLEANING****WARNING**

- Solvent cleaning compound MIL-PRF-680 Type III is an environmentally compliant and low toxic material. However, it may be irritating to the eyes and skin. Use protective gloves and goggles. Use in well-ventilated areas. Keep away from open flames and other sources of ignition. Failure to do so may result in injury or death to personnel.
- Particles blown by compressed air are hazardous. DO NOT exceed 15 PSI (103 kPa) nozzle pressure when drying parts with compressed air. DO NOT direct compressed air against human skin. Make sure air stream is directed away from user and other personnel in the area. To prevent injury, user must wear protective goggles or face shield. Failure to follow this warning may result in injury to personnel.

Use solvent cleaning compound to clean all parts. Dry thoroughly with moisture-free compressed air or clean rags.

**END OF TASK****INSPECTION**

1. Inspect timing gear cover (Figure 1, Item 1) for cracks and distortion; replace if cracked or distorted.
2. Inspect all other parts for cracks, damage, and distortion; replace part if any of these conditions are observed.

**END OF TASK**

**INSTALLATION**

1. Install new seal (Figure 1, Item 18), bracket (Figure 1, Item 17), two screws (Figure 1, Item 16), pin (Figure 1, Item 15), new O-ring (Figure 1, Item 14), and retaining ring (Figure 1, Item 13) on rear timing gear cover (Figure 1, Item 8).
2. Install new gasket (Figure 1, Item 12), access cover (Figure 1, Item 11), and two bolts (Figure 1, Item 10) on rear timing gear cover (Figure 1, Item 8).
3. Position new gasket (Figure 1, Item 9) on front of engine block and install rear timing gear cover (Figure 1, Item 8).
4. Install camshaft and gear on rear timing gear cover (Figure 1, Item 8) (WP 0283).
5. Install fuel injection pump drive gear (WP 0234).
6. Position front timing gear cover (Figure 1, Item 1) on rear timing gear cover (Figure 1, Item 8).
7. Install 22 mounting bolts (Figure 1, Item 6) and new bolt seal (Figure 1, Item 7) on front timing gear cover (Figure 1, Item 1). Tighten bolts to 18 lb-ft (24 Nm).
8. Install crankshaft seal (Figure 1, Item 5) (WP 0277).
9. Install crankshaft pulley (Figure 1, Item 4), hub (Figure 1, Item 3), and four bolts (Figure 1, Item 2) on front timing gear cover (Figure 1, Item 1). Tighten bolts to 86 to 96 lb-ft (116 to 130 Nm).

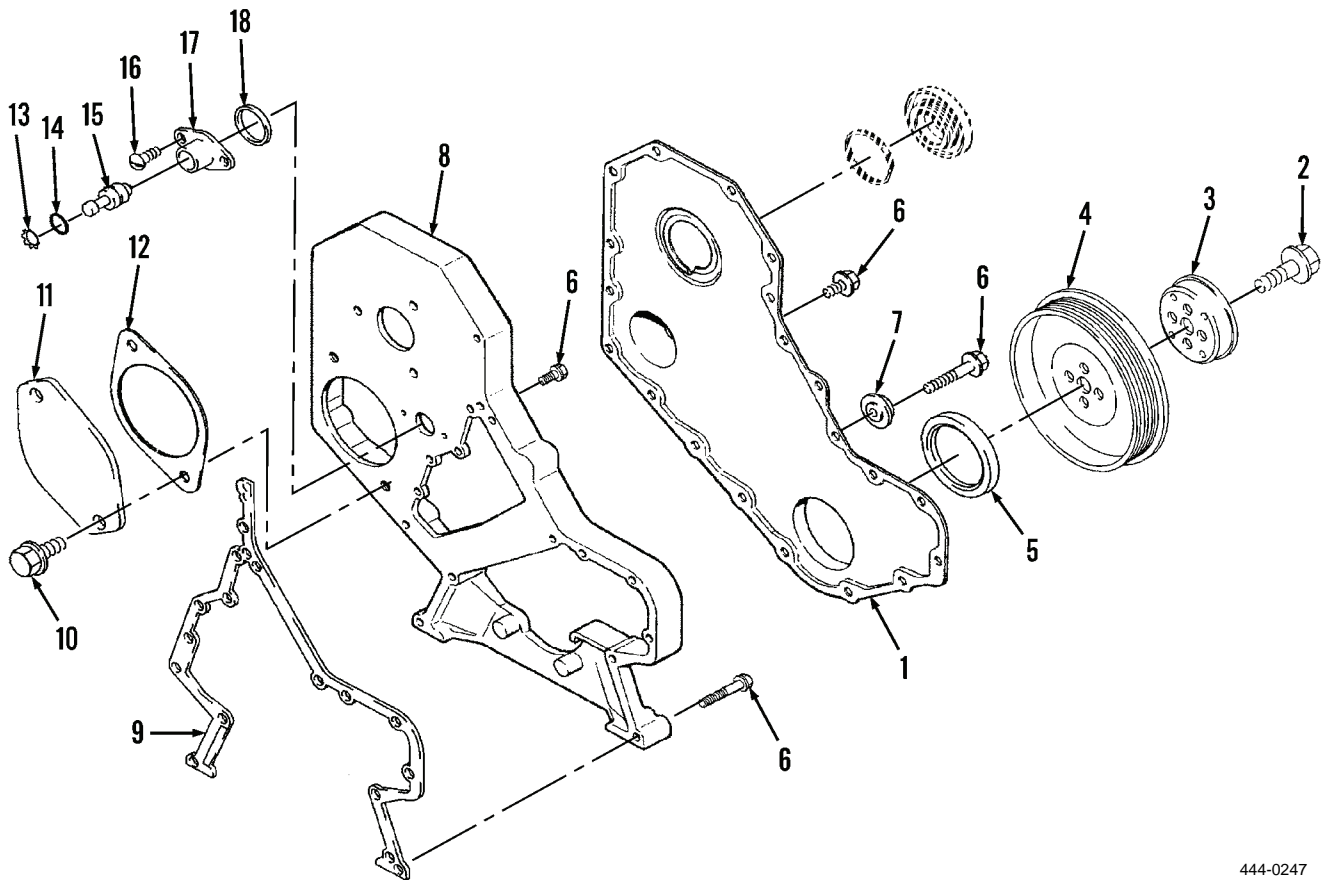

Figure 1. Timing Gear Cover Assembly.

444-0247

**END OF TASK**

**END OF WORK PACKAGE**





---

## GENERAL SUPPORT MAINTENANCE INSTRUCTIONS

### OIL PUMP MAINTENANCE (MODEL 207)

Removal, Disassembly, Cleaning, Inspection, Assembly, Installation

---

#### INITIAL SETUP

##### Maintenance Level

General Support

##### Tools and Special Tools

Tool kit, general mechanic's (Item 15, WP 0309)  
Shop equipment, common no. 1 (Item 2, WP 0309)  
Thickness gage (NSN 5210-00-221-1999)

##### Materials/Parts

Cleaning compound, solvent (Item 10, WP 0310)  
Lubricating oil, OE/HDO-15/40 (Item 21, WP 0310)

##### Materials/Parts - Continued

Plastigage (Item 5, WP 0310)  
Rag, wiping (Item 26, WP 0310)  
Cotter pin  
Gasket  
Lockwasher (4)  
O-ring

##### Equipment Condition

Oil pan removed (WP 0226)

---

**REMOVAL**

1. Remove two capscrews (Figure 1, Item 2) and washers (Figure 1, Item 3) from oil pump screen.
2. Remove two capscrews (Figure 1, Item 1) from oil pump (Figure 1, Item 4).
3. Remove oil pump (Figure 1, Item 4) from cylinder block.
4. Remove shim(s) (Figure 1, Item 5) from oil pump (Figure 1, Item 4).

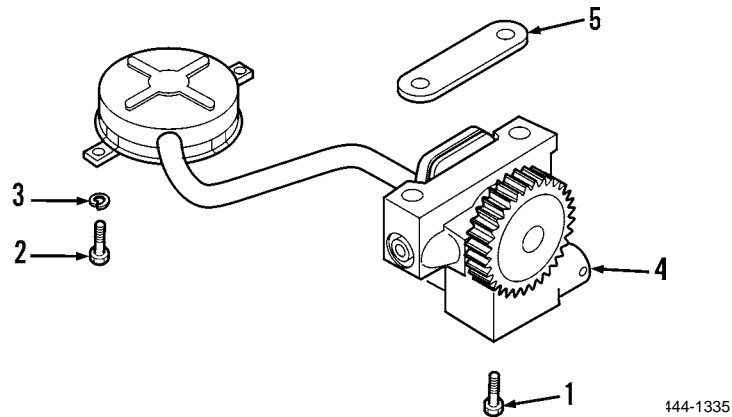
**Figure 1. Oil Pump.****DISASSEMBLY**

1. Remove oil pump screen (Figure 2, Item 1) from oil pump body (Figure 2, Item 13).
2. Remove three capscrews (Figure 2, Item 2) and lockwashers (Figure 2, Item 3) from cover assembly (Figure 2, Item 6). Discard lockwashers.
3. Remove screw (Figure 2, Item 4) and lockwasher (Figure 2, Item 5) from cover assembly (Figure 2, Item 6). Discard lockwasher.
4. Remove cover assembly (Figure 2, Item 6) and gasket (Figure 2, Item 7) from oil pump body (Figure 2, Item 13). Discard gasket.
5. Remove O-ring (Figure 2, Item 8) from oil pump body (Figure 2, Item 13). Discard O-ring.
6. Remove cotter pin (Figure 2, Item 9) from oil pump body (Figure 2, Item 13). Discard cotter pin.
7. Remove spring retainer (Figure 2, Item 10), relief valve spring (Figure 2, Item 11), and relief valve (Figure 2, Item 12) from oil pump body (Figure 2, Item 13).

## DISASSEMBLY - CONTINUED

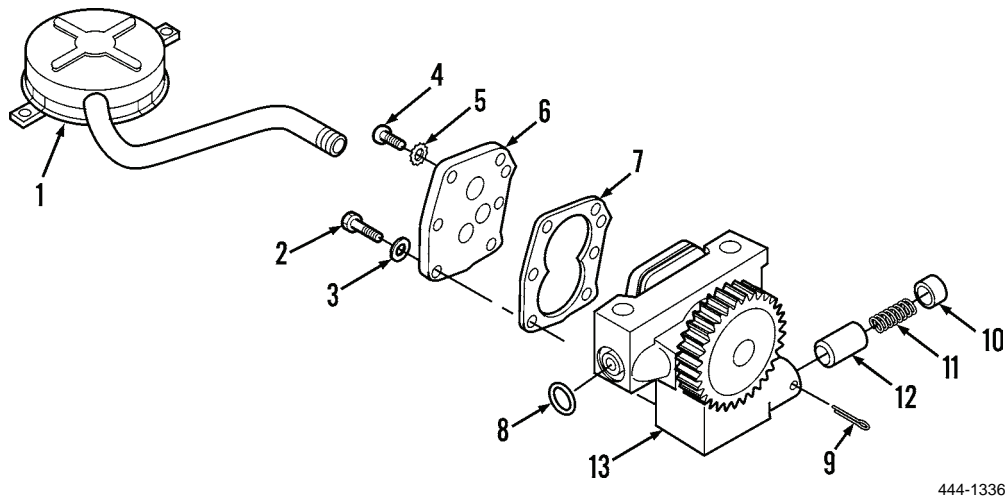

444-1336

Figure 2. Oil Pump Assembly.

## END OF TASK

## CLEANING



WARNING



- Solvent cleaning compound MIL-PRF-680 Type III is an environmentally compliant and low toxic material. However, it may be irritating to the eyes and skin. Use protective gloves and goggles. Use in well-ventilated areas. Keep away from open flames and other sources of ignition. Failure to do so may result in injury or death to personnel.
- Particles blown by compressed air are hazardous. DO NOT exceed 15 PSI (103 kPa) nozzle pressure when drying parts with compressed air. DO NOT direct compressed air against human skin. Make sure air stream is directed away from user and other personnel in the area. To prevent injury, user must wear protective goggles or face shield. Failure to follow this warning may result in injury to personnel.

1. Immerse oil pump screen (Figure 2, Item 1) in solvent cleaning compound. Clean all solidified lubricant/sludge from screen and inside suction tube. Dry with moisture-free compressed air.
2. Use solvent cleaning compound to clean all other parts. Dry with moisture-free compressed air or clean rag.

## END OF TASK

## INSPECTION

1. Use feeler gauge to check pump drive gear as shown (Figure 3) and check pump drive gear-to-oil pump body clearance. Clearance must not exceed 0.010 in. (0.25 mm); if clearance exceeds this dimension, replace oil pump.

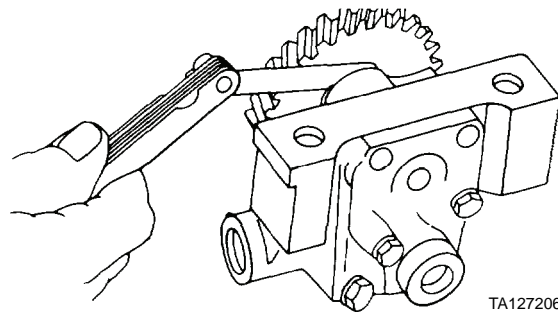

**Figure 3. Pump Drive Gear-to-Oil Pump Clearance Check.**

2. Use feeler gauge to check pump gears as shown (Figure 4) and check pump gears-to-body radial clearance. Clearance should not exceed 0.008 in. (0.20 mm). Replace oil pump if clearance exceeds this dimension.

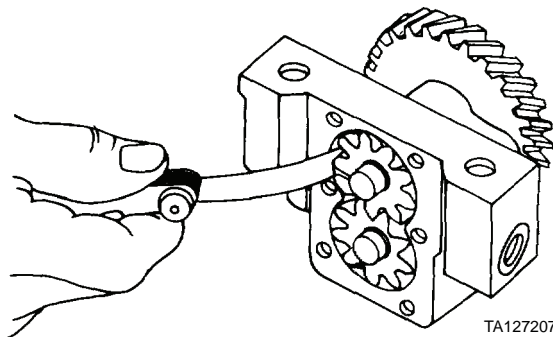

**Figure 4. Pump Gears-to-Body Radial Clearance Check.**

3. Place plastigage on pump gear. Install new gasket (Figure 5, Item 7), cover assembly (Figure 5, Item 6), three capscrews (Figure 5, Item 2), and new lockwashers (Figure 5, Item 3). Tighten capscrews to 6 to 8 lb-ft (8 to 11 Nm). Remove cover assembly and measure plastigage to obtain gear-to-cover clearance. Clearance must not exceed 0.008 in. (0.20 mm). Replace oil pump if clearance is greater than this dimension.
4. Ensure free length of relief valve spring (Figure 5, Item 11) is 2.125 in. (54 mm) and load required to compress spring to 1.44 in. (37 mm) is 18 to 19 lb (8.2 to 8.6 kg). Replace spring if none of these conditions are met.
5. Replace oil pump screen (Figure 5, Item 1) if torn or if suction tube bent, dented, or cracked.
6. Replace relief valve (Figure 5, Item 12) and spring retainer (Figure 5, Item 10) if damaged or distorted.

## END OF TASK

## ASSEMBLY

1. Install relief valve (Figure 5, Item 12) on oil pump body (Figure 5, Item 13) with closed end toward oil pump.
2. Install relief valve spring (Figure 5, Item 11) on oil pump body (Figure 5, Item 13).
3. Install spring retainer (Figure 5, Item 10) on oil pump body (Figure 5, Item 13) with closed end outward.
4. Compress spring (Figure 5, Item 11) and spring retainer (Figure 5, Item 10) until spring retainer is below cotter pin hole. Install new cotter pin (Figure 5, Item 9) and bend it to retain in place.

**ASSEMBLY - CONTINUED****NOTE**

While tightening screw and capscrews, position cover assembly to provide free rotation of oil pump gears.

5. Position new gasket (Figure 5, Item 7) and cover assembly (Figure 5, Item 6) and install three capscrews (Figure 5, Item 2), screw (Figure 5, Item 4), and four new lockwashers (Figure 5, Items 3 and 5) on cover assembly. Tighten capscrews and screw to 6 to 8 lb-ft (8 to 11 Nm).
6. Use clean engine oil to lubricate new O-ring (Figure 5, Item 8) and install on oil pump body (Figure 5, Item 13).
7. Install oil pump screen (Figure 5, Item 1) on oil pump body (Figure 5, Item 13).

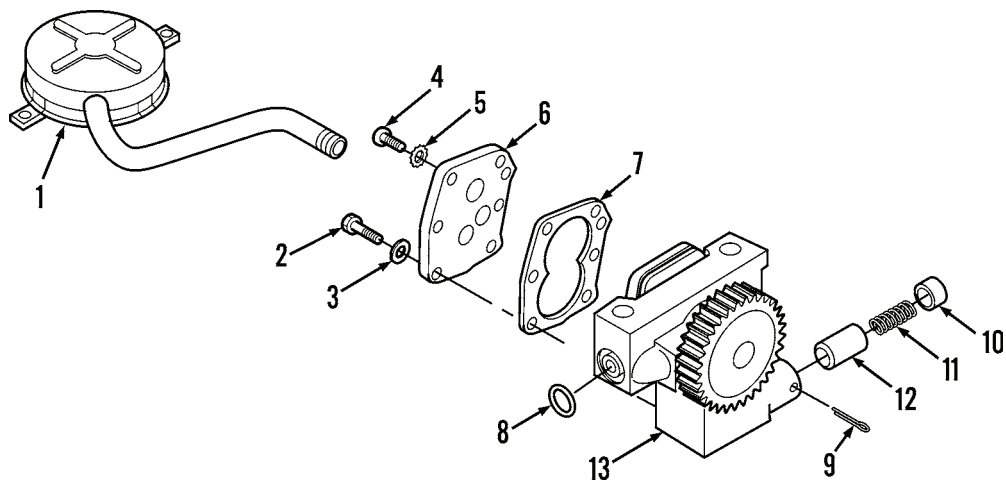

444-13336

**Figure 5. Oil Pump Assembly.****END OF TASK**

**INSTALLATION**

1. Position shim(s) (Figure 7, Item 5) on top of front main bearing cap.

**CAUTION**

In step 2, be careful not to cut O-ring on sharp edge of cylinder block when installing oil pump.

**NOTE**

Install a shim pack with 0.015 in. (0.38 mm) minimum thickness to ensure pump gear and crankshaft gear are not jammed together.

2. Position oil pump assembly (Figure 7, Item 4) on top of shim(s) (Figure 7, Item 5) and front main bearing cap.
3. Install two capscrews (Figure 7, Item 1) on oil pump (Figure 7, Item 4) and tighten to 90 to 100 lb-ft (122 to 136 Nm).
4. Install two capscrews (Figure 7, Item 2) and washers (Figure 7, Item 3) on oil pump screen and tighten capscrews to 90 to 100 lb-ft (122 to 136 Nm).

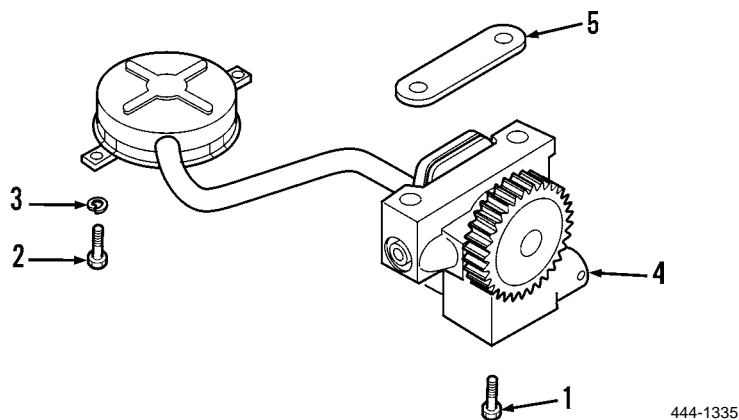

**Figure 6. Oil Pump.**

5. Use dial indicator to check backlash of oil pump drive gear as shown (Figure 7). Check backlash between oil pump drive gear and crankshaft gear. Backlash must be between 0.002 and 0.008 in. (0.05 and 0.20 mm). Add shims (Figure 7, Item 5) to increase or remove shims to decrease backlash.

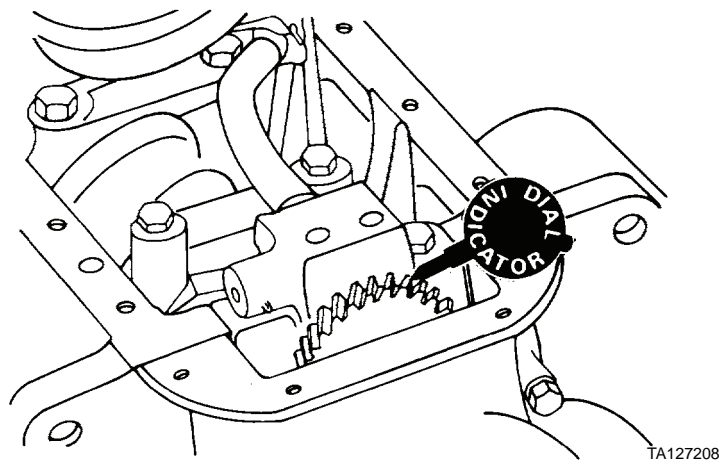

**Figure 7. Oil Pump Drive Gear Backlash Measurement.**

**END OF TASK**

**END OF WORK PACKAGE**

---

## GENERAL SUPPORT MAINTENANCE INSTRUCTIONS

### OIL PUMP REPLACEMENT (MODEL 4-390)

Removal, Cleaning, Inspection, Installation

---

#### INITIAL SETUP

##### Maintenance Level

General Support

##### Tools and Special Tools

Tool kit, general mechanic's (Item 15, WP 0309)

Shop equipment, common no. 1 (Item 2, WP 0309)

Thickness gage (NSN 5210-00-221-1999)

##### Materials/Parts

Cleaning compound, solvent (Item 10, WP 0310)

##### Materials/Parts - Continued

Rag, wiping (Item 26, WP 0310)

##### Equipment Condition

Vehicle parked on level surface

Engine OFF

Parking brake applied

Timing gear cover removed (WP 0285)

Fan pulley bracket removed (WP 0091)

---

**REMOVAL**

1. Remove four oil pump bolts (Figure 1, Item 1) from cylinder block.
2. Remove oil pump (Figure 1, Item 2) from cylinder block.

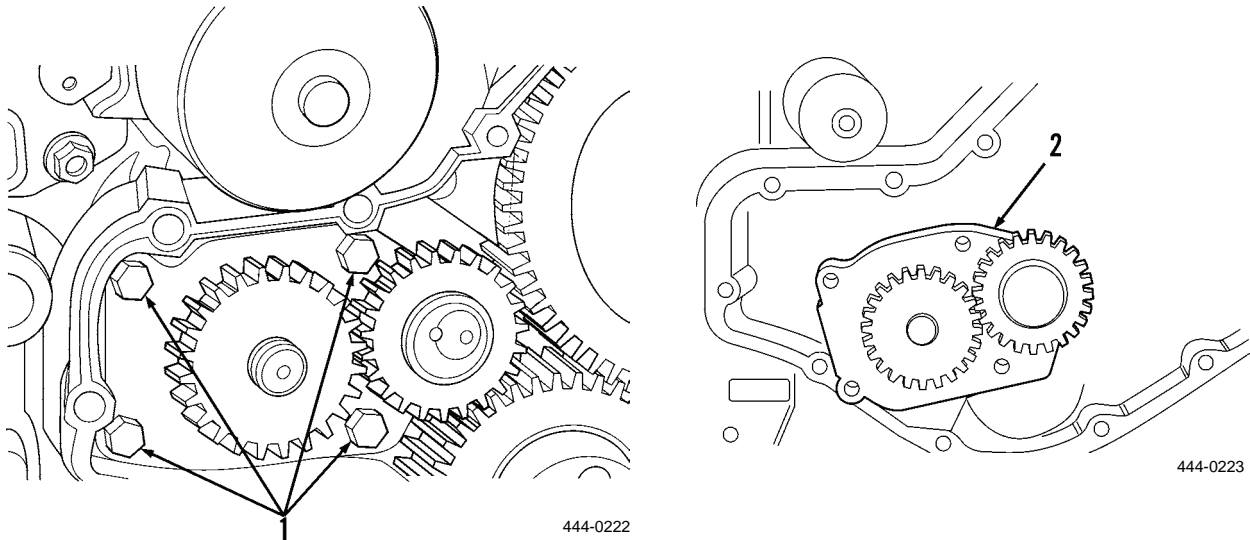
**Figure 1. Oil Pump.****END OF TASK****CLEANING****WARNING**

- Solvent cleaning compound MIL-PRF-680 Type III is an environmentally compliant and low toxic material. However, it may be irritating to the eyes and skin. Use protective gloves and goggles. Use in well-ventilated areas. Keep away from open flames and other sources of ignition. Failure to do so may result in injury or death to personnel.
- Particles blown by compressed air are hazardous. DO NOT exceed 15 PSI (103 kPa) nozzle pressure when drying parts with compressed air. DO NOT direct compressed air against human skin. Make sure air stream is directed away from user and other personnel in the area. To prevent injury, user must wear protective goggles or face shield. Failure to follow this warning may result in injury to personnel.

Use solvent cleaning compound to clean all other parts. Dry with moisture-free compressed air or clean rags.

**END OF TASK**



**INSPECTION**

1. Use feeler gauge to check pump drive gear-to-oil pump body clearance. Clearance should be 0.076 to 0.013 in. (1.93 to 0.33 mm); if clearance exceeds this dimension, replace oil pump.
2. Use feeler gauge to check pump gears (Figure 2, Items 3 and 4). Backlash should be 0.003 to 0.013 in. (0.08 to 0.33 mm). Replace oil pump if backlash exceeds this dimension.

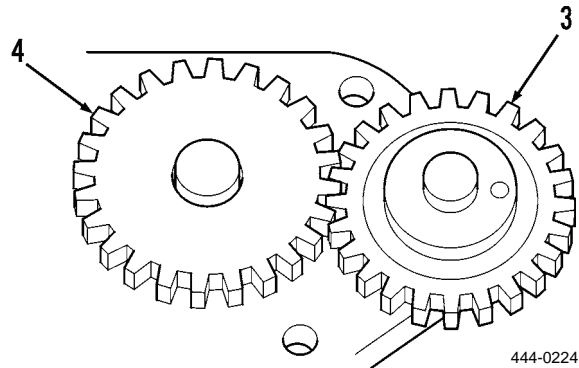
**Figure 2. Pump Gears Backlash.****END OF TASK****INSTALLATION**

1. Position oil pump (Figure 3, Item 2) on cylinder block.
2. Install four oil pump bolts (Figure 3, Item 1). Tighten bolts to 15 to 20 lb-ft (20 to 27 Nm).

**CAUTION**

Do not tighten bolts over 20 lb-ft (27 Nm) torque or damage to oil pump may result.

3. Use feeler gauge to check oil pump drive gear and crankshaft gear backlash. Backlash should be 0.003 to 0.013 in. (0.08 to 0.33 mm).

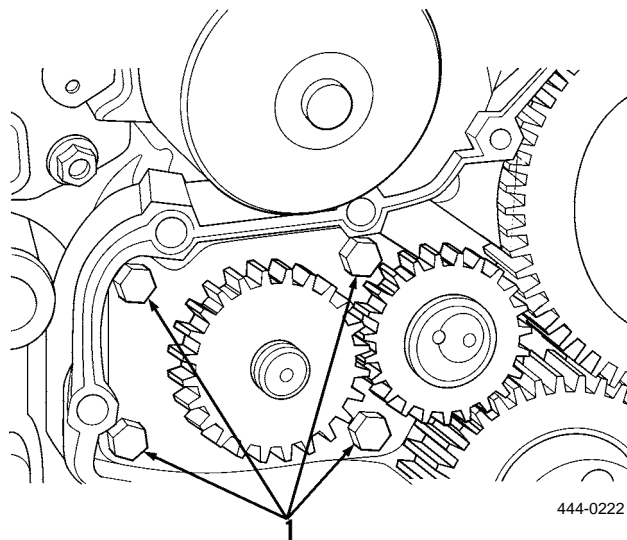
**Figure 3. Oil Pump.****END OF TASK****END OF WORK PACKAGE**



---

## GENERAL SUPPORT MAINTENANCE INSTRUCTIONS

### FUEL INJECTOR REPAIR (MODEL 207)

Testing, Disassembly, Cleaning, Inspection, Repair, Assembly, Adjustment

---

#### INITIAL SETUP

##### Maintenance Level

General Support

##### Tools and Special Tools

Tool kit, general mechanic's (Item 15, WP 0309)  
 Adapter  
 Brass wire brush (commercially available)  
 Carbon seal tool (P/N A42499)  
 Cleaning wires (P/N 66-0036)  
 Fuel injector test stand with compression gauge  
 (P/N M20322)  
 Sac hole drill (P/N 66-0151)  
 Sharpening stone (NSN 5345-00-198-8050)  
 Tip seat scraper (P/N 66-0149)  
 Torque wrench adapter (P/N 66-0146)  
 Valve retractor (P/N 66-0148)

##### Tools and Special Tools - Continued

Wire brush, brass  
 Wrench (P/N AN9508-6)

##### Materials/Parts

Cleaning compound, solvent (Item 10, WP 0310)  
 Diesel fuel, arctic (Item 14, WP 0310)  
 Diesel fuel, DF-2 (Item 15, WP 0310)  
 Rag, wiping (Item 26, WP 0310)  
 Lapping compound (P/N 66-0145)  
 Carbon dam seal  
 Compression seal

##### Equipment Condition

Fuel injector removed from engine (WP 0231)

---

#### NOTE

Always test performance of a fuel injector before disassembling. If fuel injector tests are satisfactory, there is no need to disassemble or adjust.

**TESTING****CAUTION**

Do not use motorized equipment or steel wire brushes for cleaning as orifices in body will be destroyed.

**NOTE**

Do not scrape or brush Teflon coating above carbon steel groove.

1. Ensure fuel injector is clean by removing loose carbon from tip, carbon seal groove, and body below groove using brass wire brush as shown (Figure 1).

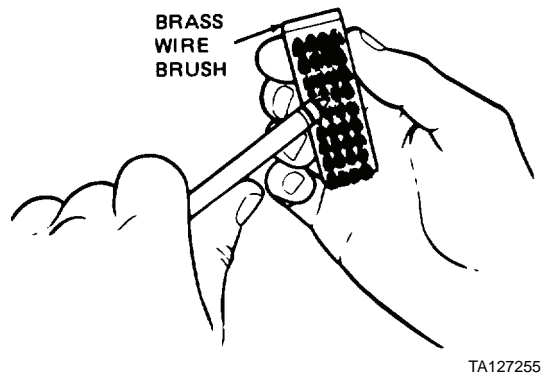

**Figure 1. Cleaning Fuel Injector.**

**TESTING - CONTINUED**

2. Install fuel injector on test stand. Do not attempt to connect fuel injector inlet fitting directly to standard, metric or 60 degree swaged type as damage to tubing can result. Use suitable adapter.

**WARNING**

Always direct injector tip away from you. Fuel from spray orifices can penetrate clothing and skin causing serious infection. Always be sure injector tip is enclosed in a receptacle (preferably transparent) to contain spray. If skin is broken by fuel injector spray, get medical attention immediately. Failure to do so may result in injury or death to personnel.

3. Perform opening pressure check by closing pressure gauge valve and flush fuel injector by operating test pump rapidly.

**NOTE**

When testing more than one fuel injector out of engine, there must not be more than 100 PSI (689 kPa) difference between any injectors in that engine.

4. Open gauge and raise pressure slowly until injector valve opens. (gauge reading will drop sharply at this point.). Opening pressure for new fuel injectors must be 3,150 to 3,250 PSI (21,718 to 22,408 kPa); for used injectors 2,950 to 3,050 PSI (20,340 to 21,029 kPa). Note and record opening pressure.
5. If injectors are not within 3,150 to 3,250 PSI (21,718 to 22,408 kPa) (new injectors) or 2,950 to 3,050 PSI (20,340 to 21,029 kPa) (used injectors) opening pressure:
  - a. Adjust new fuel injectors (see *Adjustment* in this work package).
  - b. Valve lift screw may require adjustment (see *Adjustment* in this work package).
  - c. Disassemble and clean used fuel injectors (see *Disassembly* in this work package).
  - d. Check for broken or weak opening pressure control spring (see *Inspection* in this work package).
6. Perform seat leakage check as follows:
  - a. Point injector tip down.
  - b. Operate test pump rapidly to seat valve firmly.
  - c. Raise pressure at fuel injector 200 to 300 PSI (1,379 to 2,068 kPa) under recorded opening pressure. A drop should not form on injector tip within 10 seconds. Slight dampness is permissible with a used injector.
  - d. If drop forms on injector tip, disassemble and clean fuel injector (see *Disassembly* in this work package).
  - e. If valve is not free, lap valve to tip seat (see *Repair* in this work package).
  - f. Inspect for pitted or cracked valve tip, eroded valve seat, or pitted and distorted body. These conditions require replacement of complete fuel injector.

**TESTING - CONTINUED**

7. Perform spray pattern check as follows:
  - a. Close pressure gauge.
  - b. Operate tester at 60 strokes per minute and observe spray pattern. Fuel shall be finely atomized and not a solid irregular spray pattern.

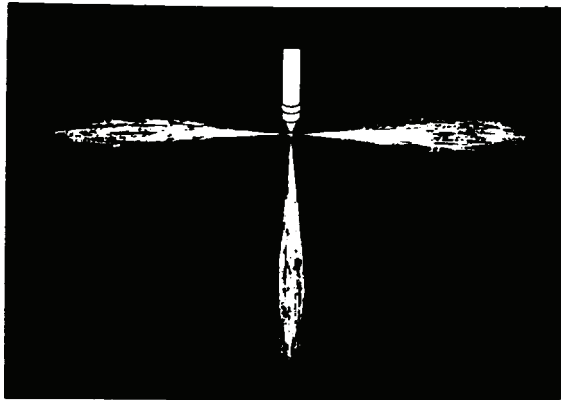
**FINE ATOMIZED SPRAY PATTERN**

TA127256

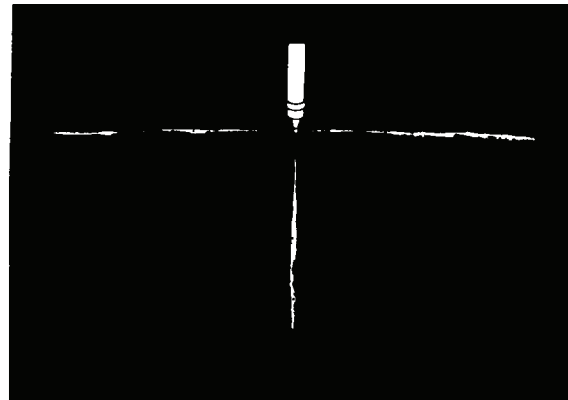
**SOLID IRREGULAR SPRAY PATTERN**

TA127257

**Figure 2. Checking Spray Pattern.**

- c. Injector will chatter when tester is operated rapidly. Chatter is an indication of valve freedom and will improve atomization. Chatter also indicates good seat width and interference angle conditions.
8. If fuel injector produces a solid irregular spray pattern, perform one or more of these steps:
  - a. Check for clogged, eroded, or chipped orifices.
  - b. Disassemble and clean fuel injector (see *Disassembly* and *Cleaning* in this work package).
  - c. Lap valve to guide area (see *Repair* in this work package).
  - d. Check for pitted or eroded valve or seat, valve interference angle worn, bent valve, and distorted body. These conditions require replacement of complete fuel injector.
9. Perform injector leak-off check as follows:
  - a. Loosen connector nuts and reposition injector tip slightly above horizontal plane.

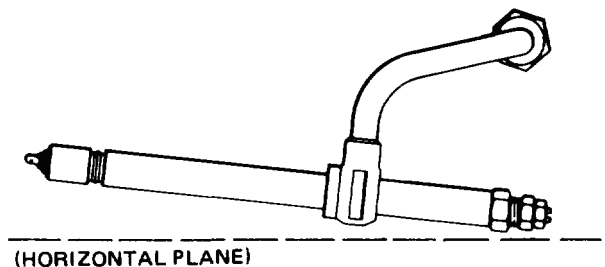

TA127258

**Figure 3. Checking Injector Leak-off.**

- b. Tighten connector nuts and raise pressure to 1,500 PSI (10,342 kPa).

**TESTING - CONTINUED**

- c. Observe leakage from return end of fuel injector. After one drop falls, leak-off must be 3 to 10 drops in 30 seconds with No. 2 diesel fuel at room temperature (65 to 75°F [18 to 24°C]).
- d. If leak-off is excessive, replace fuel injector.
- e. If leak-off is low, disassemble and clean fuel injector (see *Disassembly* and *Cleaning* in this work package).
- f. Lap valve to guide area to increase leak-off (see *Repair* in this work package).

**END OF TASK****DISASSEMBLY****CAUTION**

Fuel injector contains precision ground and lap fitted parts. Exercise care in keeping your work area and tools clean. Handle parts carefully to avoid damaging them.

1. Remove carbon dam seal (Figure 4, Item 1) and compression seal (Figure 4, Item 2) from injector body (Figure 4, Item 11). Use long-nose pliers. Discard seals.
2. Loosen pressure adjusting screw locknut (Figure 4, Item 3). If a holding tool is available, place fuel injector in holding tool and secure tool in vise; then loosen locknut.
3. Remove pressure-adjusting screw (Figure 4, Item 4). Hold injector body in one hand, invert it and back out pressure-adjusting screw, allowing spring (Figure 4, Item 5) and spring seat (Figure 4, Item 6) to fall into your other hand as shown (Figure 5).

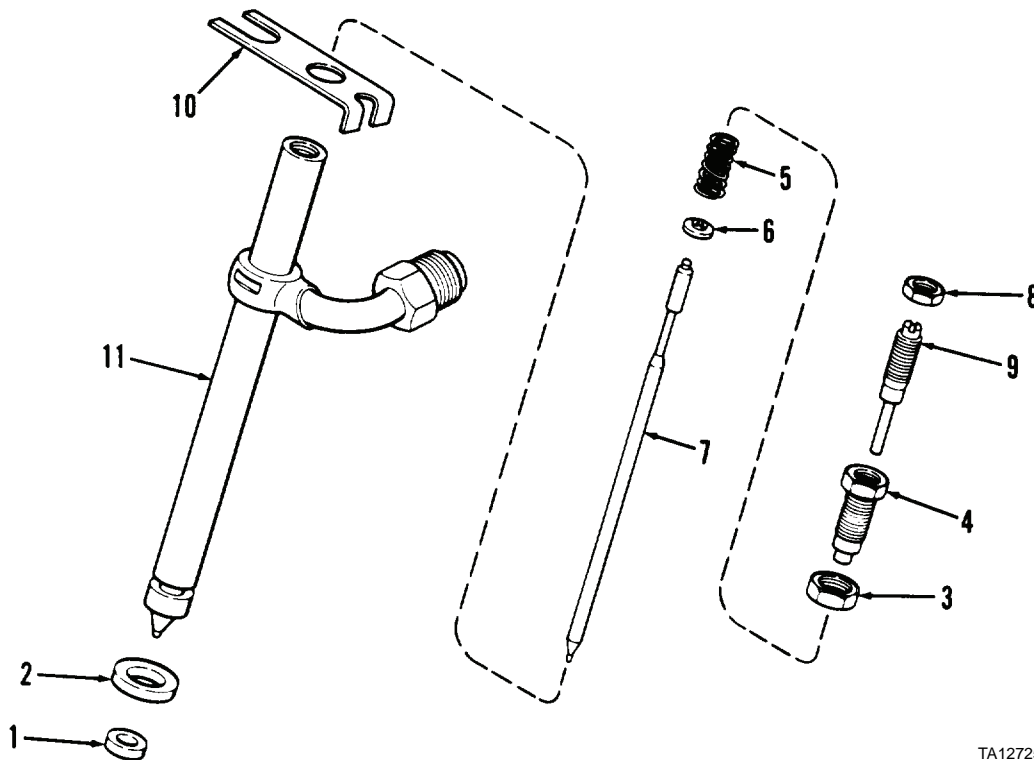

TA127259

**Figure 4. Fuel Injector.**

**DISASSEMBLY - CONTINUED**

4. Remove valve (Figure 4, Item 7). Valve may slide out of body at this time and must be handled carefully by its stem. If valve does not slide freely from body, use valve retractor P/N 66-0148 to remove. To prevent bending valve, bottom it in body with retractor. Push down on retractor body to mount collet. Turn knurled nut counterclockwise to secure collet and withdraw valve as shown (Figure 5).

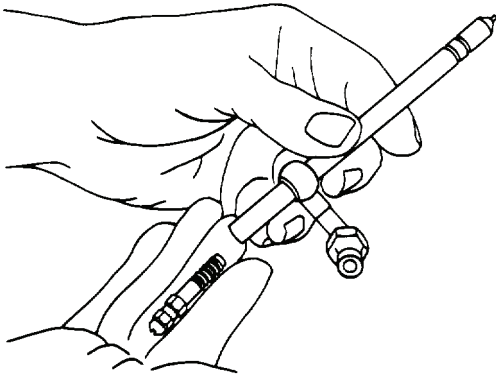

TA127260

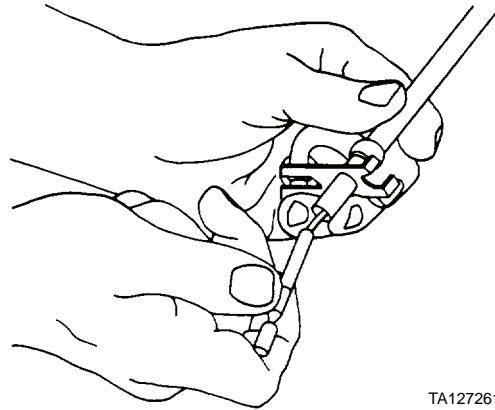

TA127261

**Figure 5. Removing Valve from Body.**

5. Remove lift-adjusting screw locknut (Figure 4, Item 8) and lift-adjusting screw (Figure 4, Item 9) from pressure-adjusting screw (Figure 4, Item 4).

**END OF TASK**



## CLEANING



WARNING

Solvent cleaning compound MIL-PRF-680 Type III is an environmentally compliant and low toxic material. However, it may be irritating to the eyes and skin. Use protective gloves and goggles. Use in well-ventilated areas. Keep away from open flames and other sources of ignition. Failure to do so may result in injury or death to personnel.

1. Clean all parts by placing all parts in solvent cleaning compound.
2. Clean injector body (Figure 4, Item 11) by using brass wire brush to clean tip of body and exterior of body.
3. Clean spray orifices of injector body (Figure 4, Item 11). Use cleaning wires P/N 66-0036 in 0.011 in. (0.28 mm) in diameter. Secure wire in pin vise with end of wire protruding 1/32 in. (0.79 mm) as shown (Figure 6). A longer length of wire will bottom on opposite wall or sac hole and tends to easily break. Use a stone to remove cutting burrs from end of wire. If a small flat is stoned on a side of wire, it will facilitate cutting carbon from orifice. Insert cleaning wire and rotate it until it is free. Flush body and inspect tip. If any orifices are chipped at edges or eroded to an extent that spray pattern is affected, replace fuel injector.
4. Clean injector body (Figure 4, Item 11) seat area. Use tip seat scraper P/N 66-0149 as shown (Figure 6).
5. Clean injector body (Figure 4, Item 11) sac hole. Use sac hole drill P/N 66-0151 and rotate it to clean deposits from sac hole. Repeat orifice cleaning (step 3).
6. Clean valve (Figure 4, Item 11). Use brush to remove deposits from seat areas, remove varnish with a solvent and felt cleaning pad. Inspect valve for pitting or erosion which could cause leakage.

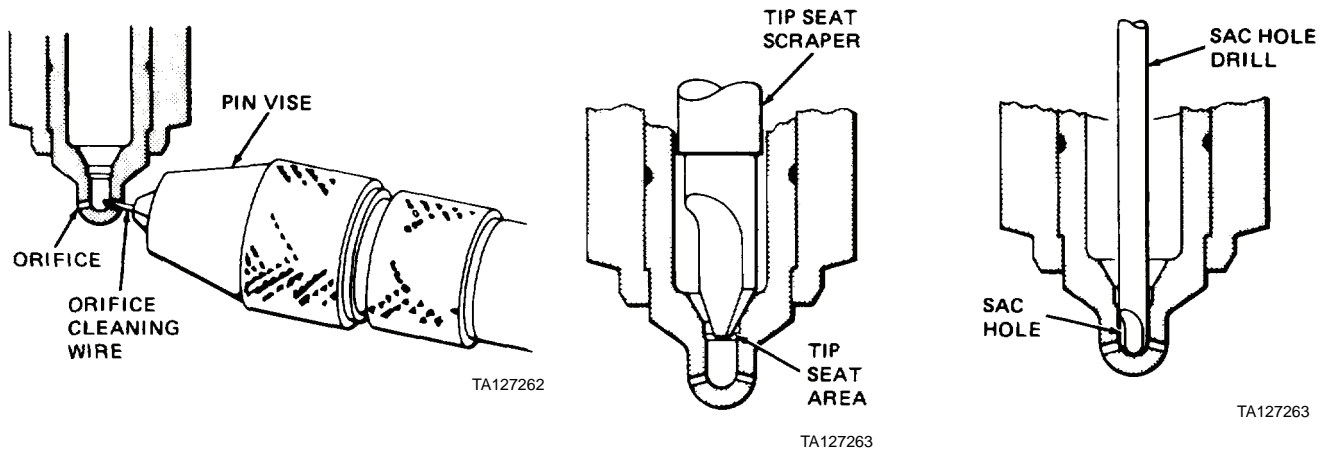

Figure 6. Cleaning Fuel Injector.

## END OF TASK

## INSPECTION

1. Inspect adjusting screws (Figure 4, Items 4 and 9). Replace if worn, or if threads are damaged.
2. Inspect spring (Figure 4, Item 5). Ensure free length of spring is 0.563 in. (14.3 mm) and compressed length is 0.456 to 0.478 in. 11.6 to 12.1 mm) at 29 lb (13.1 kg).

## END OF TASK

## REPAIR

## CAUTION

Excessive lapping will destroy interference angle between seat and valve, causing loss of chatter with poor atomization resulting in replacement of fuel injector.

1. Lap valve and tip seat of injector body. Use lapping compound (P/N 66-0145). Place small amount of lapping compound on valve seat and insert valve in injector body. Grip top of valve with valve retractor P/N 66-0148 and rotate valve by hand, first clockwise then counterclockwise for a total of 3 to 5 revolutions. Flush injector body thoroughly; wash valve and reassemble injector and retest. If valve and seat are worn, seat may be tight, but chatter may have been lost in lapping process as shown (Figure 7). In such an instance replace fuel injector.
2. Lap valve guide area of valve and injector body as shown (Figure 7). Use lapping compound P/N 66-0145. Place small amount on guide area of valve. Bottom valve in body and grasp with valve retractor P/N 66-0148. Rotate valve 10 revolutions while raising and lowering it very slightly. Flush and wash compound from both parts, assemble fuel injector and recheck fuel leak-off. If leak-off is still low, lap guide until correct leak-off is obtained. Flush fuel injector thoroughly after lapping.

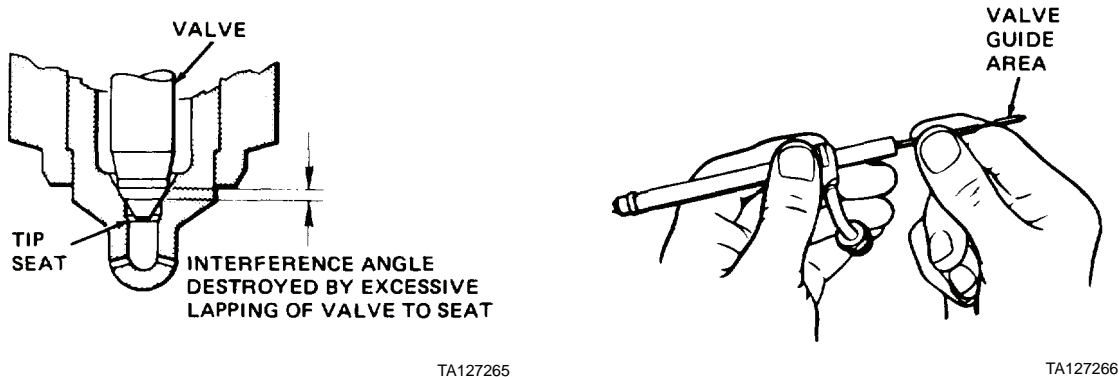
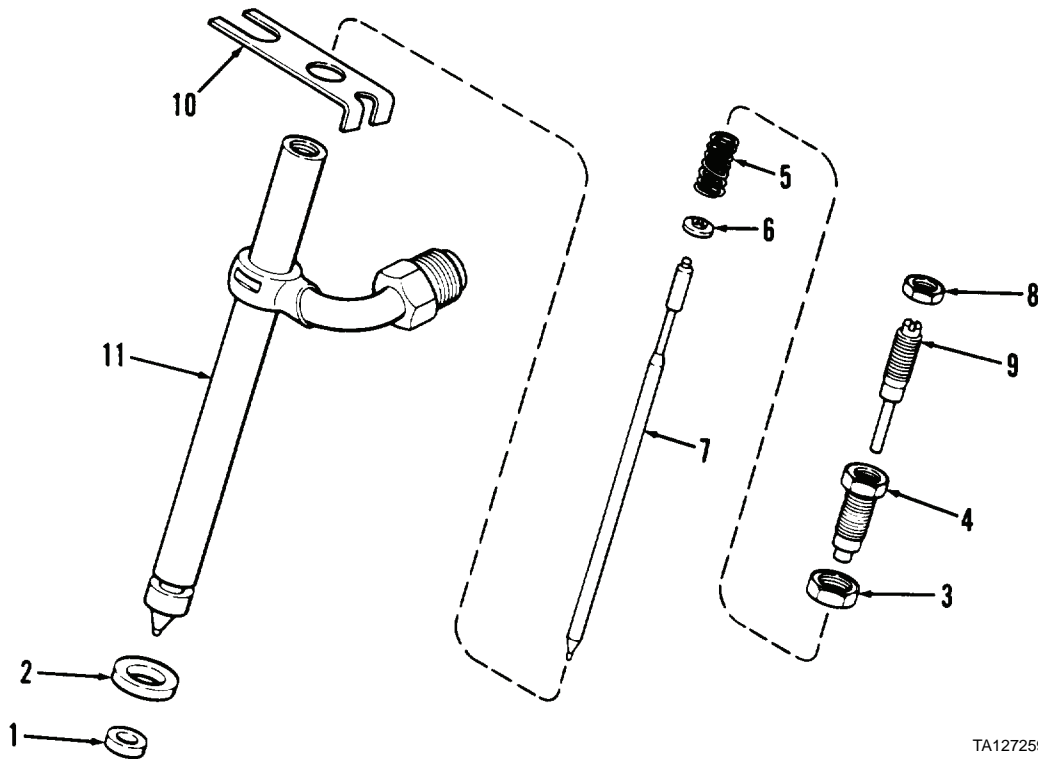

Figure 7. Lapping Valve.

## END OF TASK

**ASSEMBLY**

1. Wet all parts and hands with clean diesel fuel during assembly.
2. Install valve (Figure 8, Item 7) into injector body (Figure 8, Item 11). Handle valve by its shank and slide it partially into body.
3. Position locating plate (Figure 8, Item 10) on injector body (Figure 8, Item 11).
4. Position lift-adjusting screw (Figure 8, Item 9) with lift-adjusting screw locknut (Figure 8, Item 8) on pressure-adjusting screw (Figure 8, Item 4).
5. Install pressure-adjusting screw locknut (Figure 8, Item 3) on pressure-adjusting screw (Figure 8, Item 4).
6. Install spring (Figure 8, Item 5) and spring seat (Figure 8, Item 6) on lift- and pressure-adjusting screw assembly. Tilt injector body and, with spring seat contacting valve top, push valve (Figure 8, Item 7) and spring components into body. Take care not to dislodge spring seat during reassembly. Thread pressure-adjusting screw (Figure 8, Item 4) into injector body (Figure 8, Item 11) by hand until spring is compressed enough to hold all parts in place.
7. Install new compression seal (Figure 8, Item 2) on injector body (Figure 8, Item 11).



TA127259

**Figure 8. Fuel Injector.**

**ASSEMBLY - CONTINUED**

8. Install new carbon dam seal (Figure 9, Item 1). Use carbon seal tool P/N A42499 as shown (Figure 9). Test and adjust fuel injector.

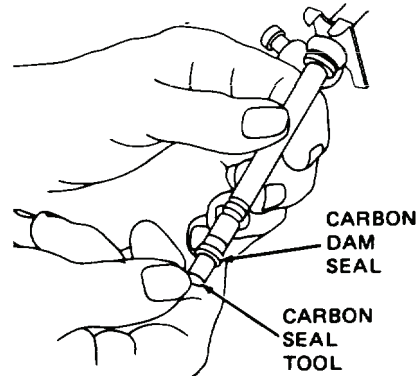

TA127267

**Figure 9. Installing Seal.****END OF TASK****ADJUSTMENT**

1. Perform opening pressure adjustment as follows:
  - a. Loosen pressure-adjusting screw locknut (Figure 9, Item 3).
  - b. Loosen lift-adjusting screw locknut (Figure 9, Item 8). Hold pressure-adjusting screw locknut (Figure 9, Item 3) while loosening.
  - c. Install fuel injector with tip downward in test stand.
  - d. Back out lift-adjusting screw (Figure 9, Item 9) one full turn.
  - e. Pump fuel through fuel injector and note opening pressure. Opening pressure should be 3,150 to 3,250 PSI (21,718 to 22,408 kPa) for new fuel injectors or 2,950 to 3,050 PSI (20,340 to 21,029 kPa) for used fuel injectors.
  - f. Turn pressure-adjusting screw (Figure 9, Item 4) while holding lift-adjusting screw (Figure 9, Item 9) until correct opening pressure is obtained. Do not tighten pressure-adjusting screw locknut (Figure 9, Item 3) at this time. Turn clockwise to increase opening pressure or counterclockwise to decrease opening pressure (gauge reading will drop sharply at point that fuel injector valve opens).
  - g. Perform valve lift adjustment (step 2).

---

**ADJUSTMENT - CONTINUED****CAUTION**

In step 2, do not manually bottom valve using excessive force as bending of valve can result requiring fuel injector replacement.

2. Perform valve lift adjustment as follows:
  - a. Pump fuel through fuel injector, hold pressure-adjusting screw and slowly turn lift-adjusting screw clockwise until valve ceases to open.
  - b. Raise pressure 200 to 500 PSI (1,379 to 3,447 kPa) over fuel injector opening pressure. Opening pressure for new fuel injectors is 3,150 to 3,250 PSI (21,718 to 22,408 kPa) and for used fuel injectors, 2,950 to 3,050 PSI (20,340 to 21,029 kPa). Some fuel may collect on injector tip, but a rapid dribble must not be apparent.
  - c. To set lift, turn lift-adjusting screw (Figure 9, Item 9) counterclockwise 1/2 turn. Turning lift -adjusting screw 1/2 turn sets valve lift 0.009 in. (0.23 mm) off valve seat.
  - d. Hold lift-adjusting screw (Figure 9, Item 9) and tighten lift-adjusting screw locknut (Figure 9, Item 8). Use wrench P/N AN9508-6. Tighten locknut to 40 to 45 lb-in. (4.5 to 5.1 Nm).
  - e. Recheck opening pressure adjustment and readjust if necessary (step 1).
  - f. Test fuel injector (refer to *Testing* in this work package).
  - g. Remove fuel injector from test stand.

**NOTE**

In step h, do not allow pressure-adjusting screw to turn while tightening pressure-adjusting screw locknut.

- h. Tighten pressure-adjusting screw locknut (Figure 9, Item 3).
- i. Use torque wrench adapter P/N 66-0146 to tighten pressure-adjusting screw locknut (Figure 9, Item 3) to 70 to 75 lb-in. (7.9 to 8.5 Nm).
- j. Recheck opening pressure (step 1).

**END OF TASK****END OF WORK PACKAGE**



## GENERAL SUPPORT MAINTENANCE INSTRUCTIONS

### FUEL INJECTION PUMP REPAIR (MODEL 207)

#### Disassembly, Cleaning, Inspection, Assembly, Testing

#### INITIAL SETUP

##### Maintenance Level

General Support

##### Tools and Special Tools

Tool kit, general mechanic's (Item 15, WP 0309)  
 Adapter (P/N 21900)  
 Advance plug tool (P/N 14490)  
 Advance window (P/N 19918)  
 Bristol socket cam advance screw wrench (P/N 15499)  
 Cam advance screw bushing (P/N 15500)  
 Extractor (P/N 13301)  
 Extractor (P/N 13383)  
 Fixture (P/N 19969)  
 Holding fixture (P/N 19965)  
 Holding fixture (P/N 20029)  
 Holding fixture bracket kit (P/N 19930)  
 Leaf spring adjusting screwdriver (P/N 13336)  
 Linkage hook adjustment gauge (P/N 18914)  
 Linkage hook wrench (P/N 13379)  
 Micrometer, 0 to 2 in.  
 Piston ring compressor (P/N 16199)  
 Rotor retaining ring installation tool (P/N 13375)

##### Tools and Special Tools - Continued

Shutoff cam removal tool (P/N 13339)  
 Snap ring pliers (P/N 13337)  
 Socket setscrew wrench (P/N 13316)  
 Vent wire extractor (P/N 18264)

##### Materials/Parts

Cleaning compound, solvent (Item 10, WP 0310)  
 Diesel fuel, arctic (Item 14, WP 0310)  
 Diesel fuel, DF-2 (Item 15, WP 0310)  
 Grease, automotive and artillery (Item 17, WP 0310)  
 Rag, wiping (Item 26, WP 0310)  
 Gasket (3)  
 Lockwasher (9)  
 O-ring  
 Safety wire  
 Seal (11)

##### Equipment Condition

Fuel injection pump removed from engine (WP 0233)

#### DISASSEMBLY



#### WARNING

DO NOT smoke or permit any open flame in area of machine while you are servicing fuel system. Failure to follow this warning may result in injury or death to personnel, or damage to equipment.

#### NOTE

- Before starting disassembly of fuel injection pump, cover inlet and outlet ports, wash pump with clean diesel fuel to remove all external grease and dirt, and dry with filtered, compressed air. Work space, tools, and hands must be clean during following task.
- Use a clean pan to place parts into during disassembly; a pan of clean diesel fuel or calibrating oil must be available in which parts may be flushed. These should be deep pans with rounded corners to lessen chances of dirt pockets.

**DISASSEMBLY - CONTINUED**

1. At front of fuel injection pump, pull out and remove thrust plunger (Figure 2, Item 1) and spring (Figure 2, Item 2).
2. Remove nut (Figure 2, Item 3), lockwasher (Figure 2, Item 4), drive shaft (Figure 2, Item 5), and two seals (Figure 2, Item 6) from fuel injection pump. Discard seals.

**NOTE**

Do not remove roll pin unless sheared off or damaged.

3. Remove roll pin (Figure 2, Item 7) from drive shaft (Figure 2, Item 5) if necessary. Use 5/64-in. easy-out extractor or 3/32 in. carbide-tipped drill.
4. Remove pilot tube seal (Figure 2, Item 8). Use screwdriver to pry out.
5. Install fuel injection pump in holding fixture tool P/N 20029.
6. At top of fuel injector pump, cut, remove, and discard safety wire (Figure 2, Item 9).
7. Remove three screws (Figure 2, Item 10), lockwashers (Figure 2, Item 11), and washers (Figure 2, Item 12). Discard lockwashers.
8. Remove governor control cover (Figure 2, Item 22) and gasket (Figure 2, Item 23). Discard gasket.
9. At governor control cover (Figure 2, Item 22), remove two nuts (Figure 2, Item 13), washer (Figure 2, Item 14), grounding strap (Figure 2, Item 15), and lockwashers (Figure 2, Items 16 and 17). Discard lockwashers.
10. Remove two nuts (Figure 2, Item 18), washers (Figure 2, Item 19), insulating washers (Figure 2, Item 20), and solenoid frame and arm assembly (Figure 2, Item 24).
11. Remove connector (Figure 2, Item 21).
12. At top side of fuel injection pump, remove screw (Figure 2, Item 25), spring retainer (Figure 2, Item 26), throttle lever spring (Figure 2, Item 27), throttle lever assembly (Figure 2, Item 28), and spacer adjusting arm (Figure 2, Item 29).
13. Remove screw (Figure 2, Item 30) and spacer (Figure 2, Item 31).
14. Remove shaft retainer clip (Figure 2, Item 32) by rotating shutoff shaft (Figure 2, Item 33) to full shutoff position (clip horizontal). Use shutoff cam removal tool P/N 13339 placed between housing and governor linkage hook as shown (Figure 1). Pry gently, sliding clip out of its groove and off throttle shaft.

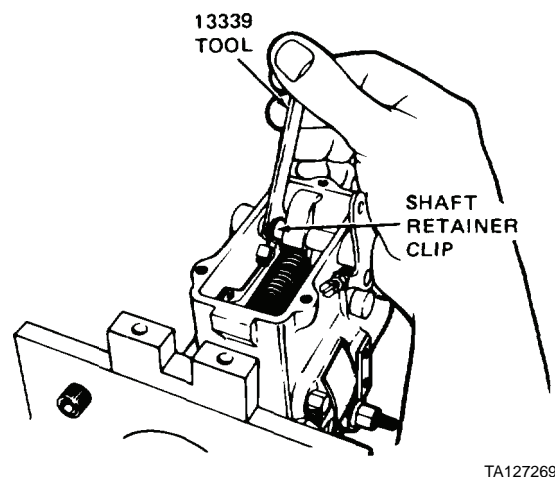

TA127269

**Figure 1. Removing Shaft Retainer Clip.**



DISASSEMBLY - CONTINUED

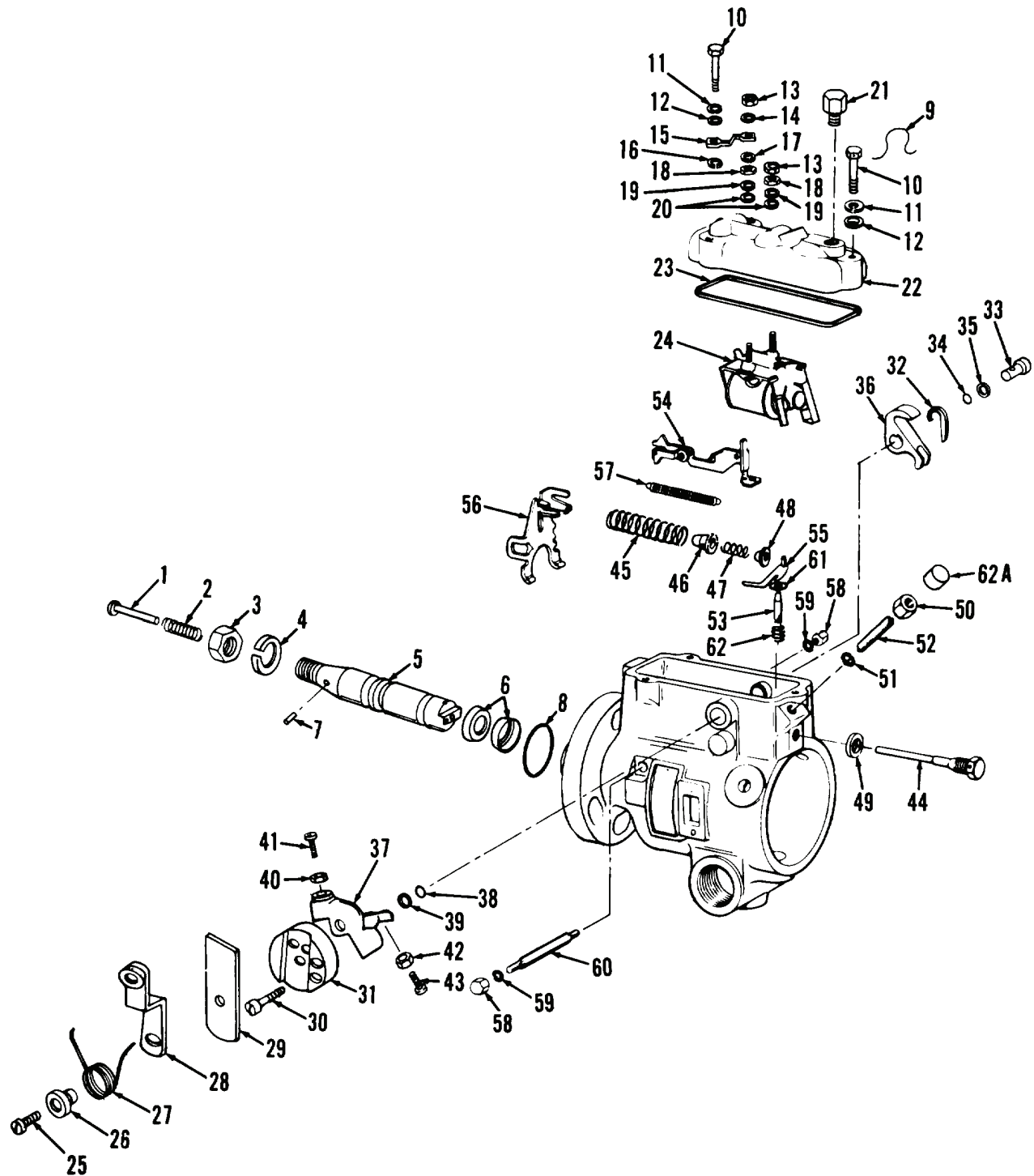
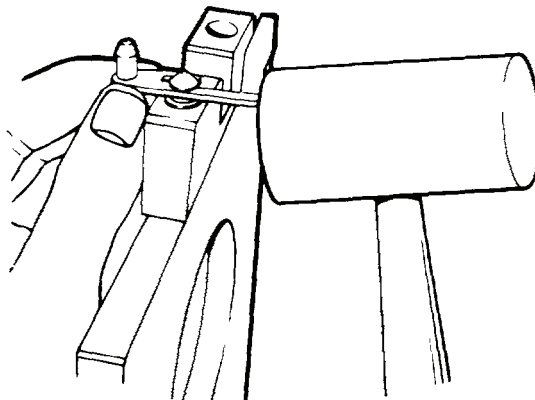

Figure 2. Fuel Injection Pump External Components.

TA127268

**DISASSEMBLY - CONTINUED**

15. Withdraw and remove shutoff shaft (Figure 4, Item 33).
16. Remove seal (Figure 4, Item 34) and washer (Figure 4, Item 35). Discard seal.
17. Remove throttle shaft lever (Figure 4, Item 36) by sliding off of throttle shaft assembly (Figure 4, Item 37).
18. Remove throttle shaft assembly (Figure 4, Item 37), seal (Figure 4, Item 38), and washer (Figure 4, Item 39) from fuel injection pump. Discard seal.
19. Loosen nut (Figure 4, Item 40) and remove low-idle adjusting screw (Figure 4, Item 41).
20. Loosen nut (Figure 4, Item 42) and remove high-idle adjusting screw (Figure 4, Item 43).
21. At rear of fuel injection pump, loosen guide stud (Figure 4, Item 44).
22. While securely holding governor spring (Figure 4, Item 45), fully remove guide stud (Figure 4, Item 44).
23. Remove governor spring (Figure 4, Item 45), spring retainer (Figure 4, Item 46), idling spring (Figure 4, Item 47), and idling spring guide (Figure 4, Item 48).
24. Remove washer (Figure 4, Item 49).
25. Remove cap (Figure 4, Item 62A), nut (Figure 4, Item 50), and seal (Figure 4, Item 51). Discard seal.
26. Remove torque screw (Figure 4, Item 52).
27. At top of fuel injection pump, depress metering valve (Figure 4, Item 53) and lift governor linkage hook assembly (Figure 4, Item 54) from metering valve arm (Figure 4, Item 55) pin.
28. Hold governor arm (Figure 4, Item 56) forward and disengage governor linkage hook (Figure 4, Item 54) from governor arm and place over side of housing. Do not disengage linkage spring (Figure 4, Item 57).
29. At top sides of fuel injection pump, remove two pivot nuts (Figure 4, Item 58) and seals (Figure 4, Item 59). Discard seals.
30. Remove governor arm pivot shaft (Figure 4, Item 60).
31. Remove governor arm (Figure 4, Item 56), governor linkage hook (Figure 4, Item 54), and linkage spring (Figure 4, Item 57).
32. Remove metering valve (Figure 4, Item 53), metering valve arm (Figure 4, Item 55), shim (Figure 4, Item 61), and spring (Figure 4, Item 62).
33. Remove metering valve arm (Figure 4, Item 55) and shim (Figure 4, Item 61) from metering valve (Figure 4, Item 53) as shown (Figure 3).



TA127273

**Figure 3. Metering Valve Arm and Shim.**

DISASSEMBLY - CONTINUED

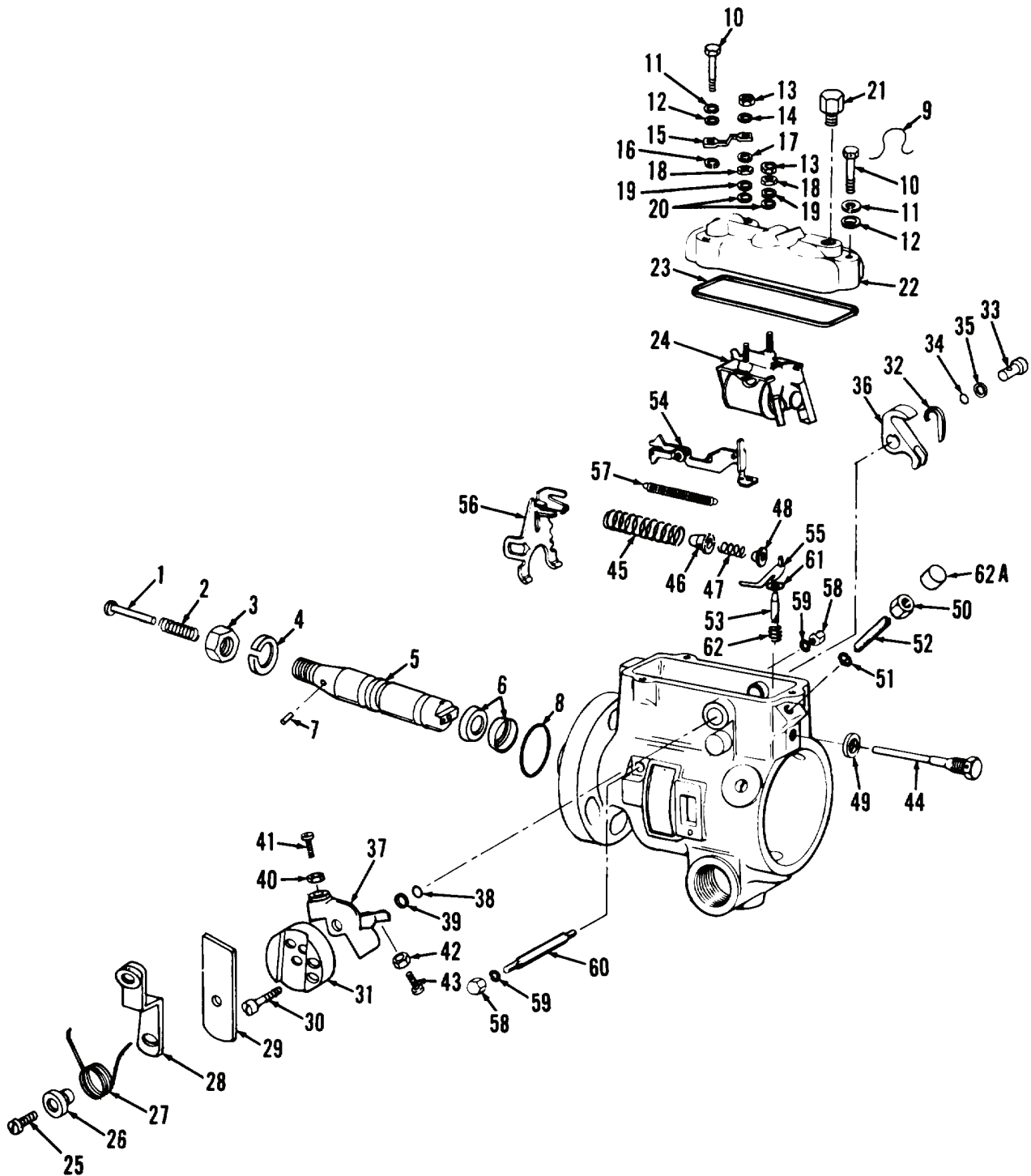

Figure 4. Fuel Injection Pump External Components.

TA127268

**DISASSEMBLY - CONTINUED**

34. At sides of fuel injection pump, loosen one head-locking screw (Figure 5, Item 63) and remove second head-locking screw.
35. Invert fuel injection pump and holding fixture in vise.
36. At bottom of fuel injection pump, remove head-locating screw (Figure 5, Item 64). Use 7/16-in. deep well socket.
37. Remove and discard two seals (Figure 5, Item 65).
38. Loosen advance screw hole plug (Figure 5, Item 66) by tapping gently with hammer.
39. Remove advance screw hole plug (Figure 5, Item 66) and seal (Figure 5, Item 67). Use advance plug tool P/N 14490. Discard seal.

**NOTE**

Power side piston is located on side of housing marked with letters CC (just above advance boss).

40. Remove advance piston hole plug (Figure 5, Item 68), piston (Figure 5, Item 71), spring (Figure 5, Item 72), and slide washer (Figure 5, Item 70) as an assembly.
41. Remove two seals (Figure 5, Item 69). Discard seals.
42. Remove slide washer (Figure 5, Item 70).
43. Invert advance piston hole plug (Figure 5, Item 68) and let piston (Figure 5, Item 71), spring (Figure 5, Item 72), and shims (Figure 5, Item 73) fall into your hand.
44. Remove spring (Figure 5, Item 72) and shims (Figure 5, Item 73) from piston (Figure 5, Item 71).
45. At other side of fuel injection pump, remove power side piston hole plug (Figure 5, Item 74), two seals (Figure 5, Item 75), and slide washer (Figure 5, Item 76). Discard seals.
46. Hold power side piston hole plug (Figure 5, Item 74) in one hand and rap sharply into palm of your other hand. Piston (Figure 5, Item 77) will slide out.
47. Remove seal (Figure 5, Item 78) and piston ring (Figure 5, Item 79) from piston (Figure 5, Item 77).

DISASSEMBLY - CONTINUED

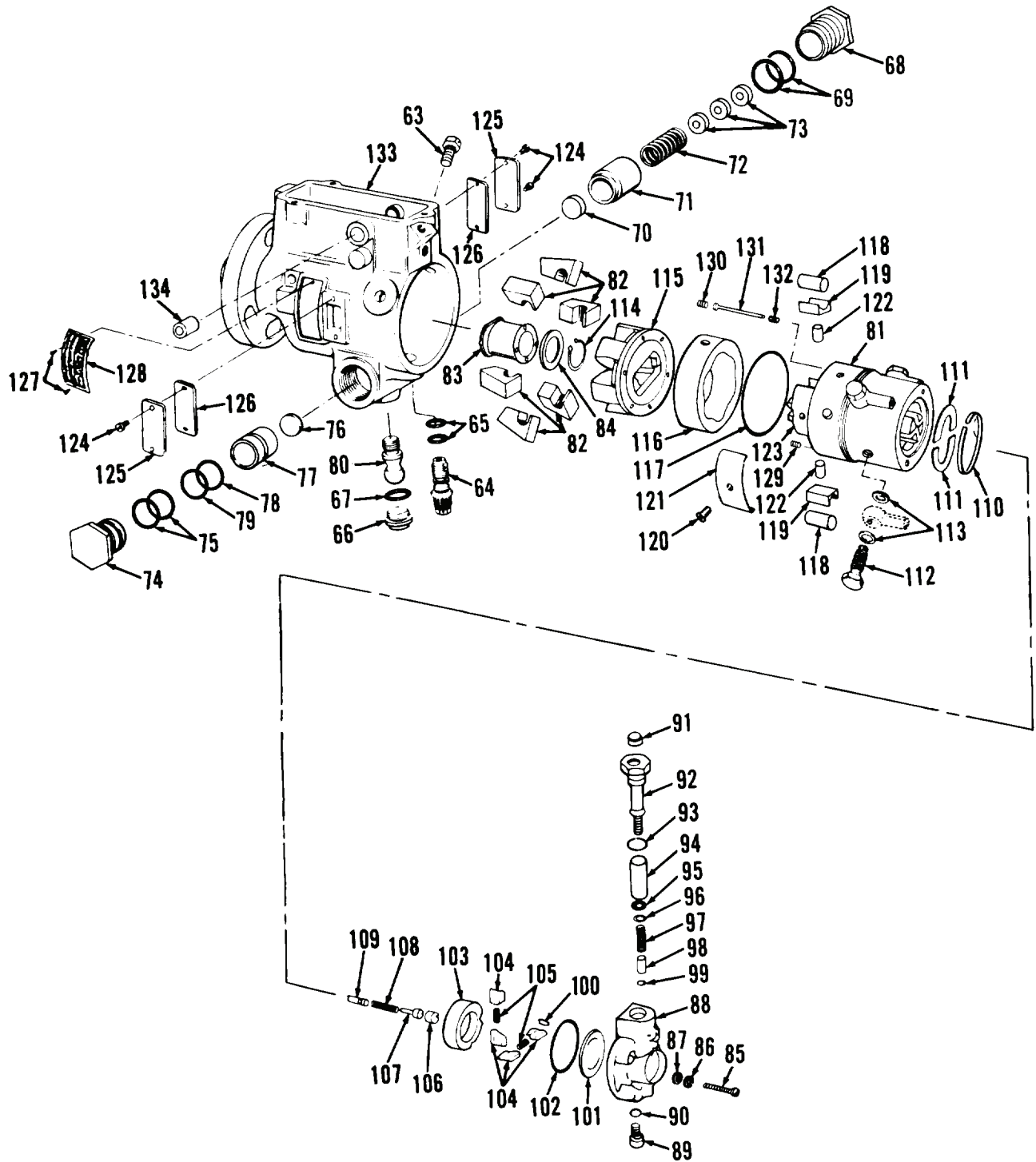

TA127274

Figure 5. Fuel Injection Pump Internal Components.

**DISASSEMBLY - CONTINUED**

48. Remove cam advance screw (Figure 7, Item 80). Assemble tools P/N 15499 and P/N 15500 into cam advance screw plug hole to remove as shown (Figure 6). Use 5/8 in. socket on tool P/N 15499.

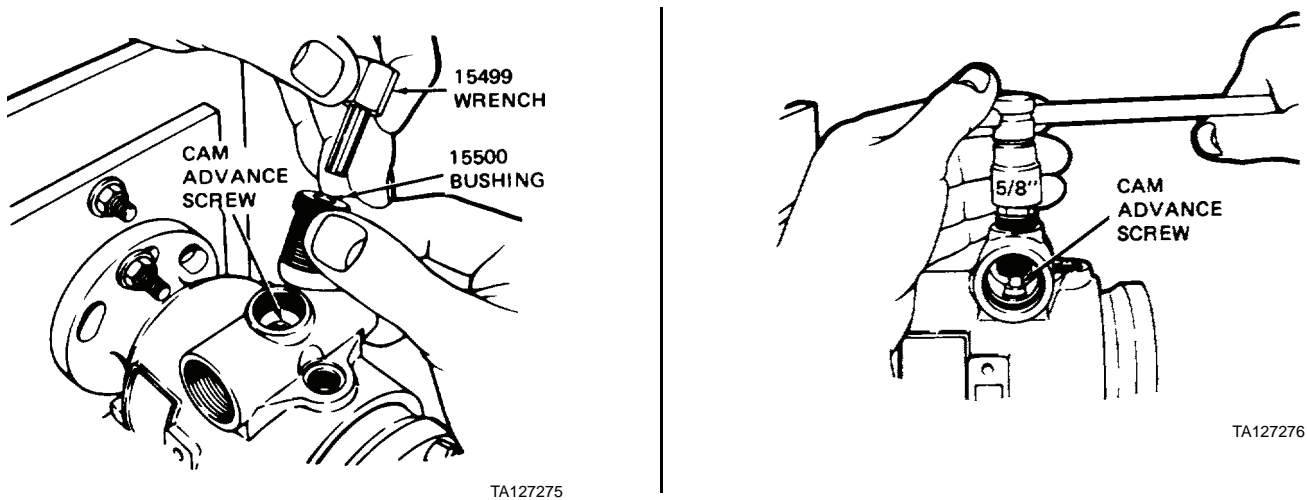

**Figure 6. Removing Cam Advance Screw.**

49. Position fuel injector pump and holding fixture in vise with rear of pump tilted slightly downward.  
 50. Remove head-locking screw (Figure 7, Item 63) loosened in step 34.

**CAUTION**

Be careful when performing step 51. Do not drop governor weights.

51. Grasp hydraulic head (Figure 7, Item 81) with both hands and, using a slight rotary motion, remove from housing (Figure 7, Item 133) of fuel injection pump.  
 52. At hydraulic head (Figure 7, Item 81), invert hydraulic head and let six governor weights (Figure 7, Item 82), thrust sleeve (Figure 7, Item 83), and thrust washer (Figure 7, Item 84) fall into your hand.  
 53. Position hydraulic head (Figure 7, Item 81) on holding fixture bracket kit tool P/N 19930 so governor weight engages bar on fixture.  
 54. Remove four screws (Figure 7, Item 85), lockwashers (Figure 7, Item 86), washers (Figure 7, Item 87), and end plate (Figure 7, Item 88) from hydraulic head (Figure 7, Item 81). Discard lockwashers.  
 55. Remove plug (Figure 7, Item 89) and seal (Figure 7, Item 90) from bottom of end plate (Figure 7, Item 88). Discard seal.  
 56. At top of end plate (Figure 7, Item 88), remove plug (Figure 7, Item 91) from sleeve (Figure 7, Item 92).  
 57. Remove sleeve (Figure 7, Item 92), seal (Figure 7, Item 93), filter element (Figure 7, Item 94), seal (Figure 7, Item 95), O-ring (Figure 7, Item 96), regulator spring (Figure 7, Item 97), piston (Figure 7, Item 98), and seal (Figure 7, Item 99) from end plate (Figure 7, Item 88) as an assembly.  
 58. Remove and discard seal (Figure 7, Item 93).  
 59. Remove filter element (Figure 7, Item 94).  
 60. Remove seal (Figure 7, Item 95) and O-ring (Figure 7, Item 96). Discard seal and O-ring.  
 61. Remove regulator spring (Figure 7, Item 97) and regulating piston (Figure 7, Item 98).  
 62. Remove and discard seal (Figure 7, Item 99).

DISASSEMBLY - CONTINUED

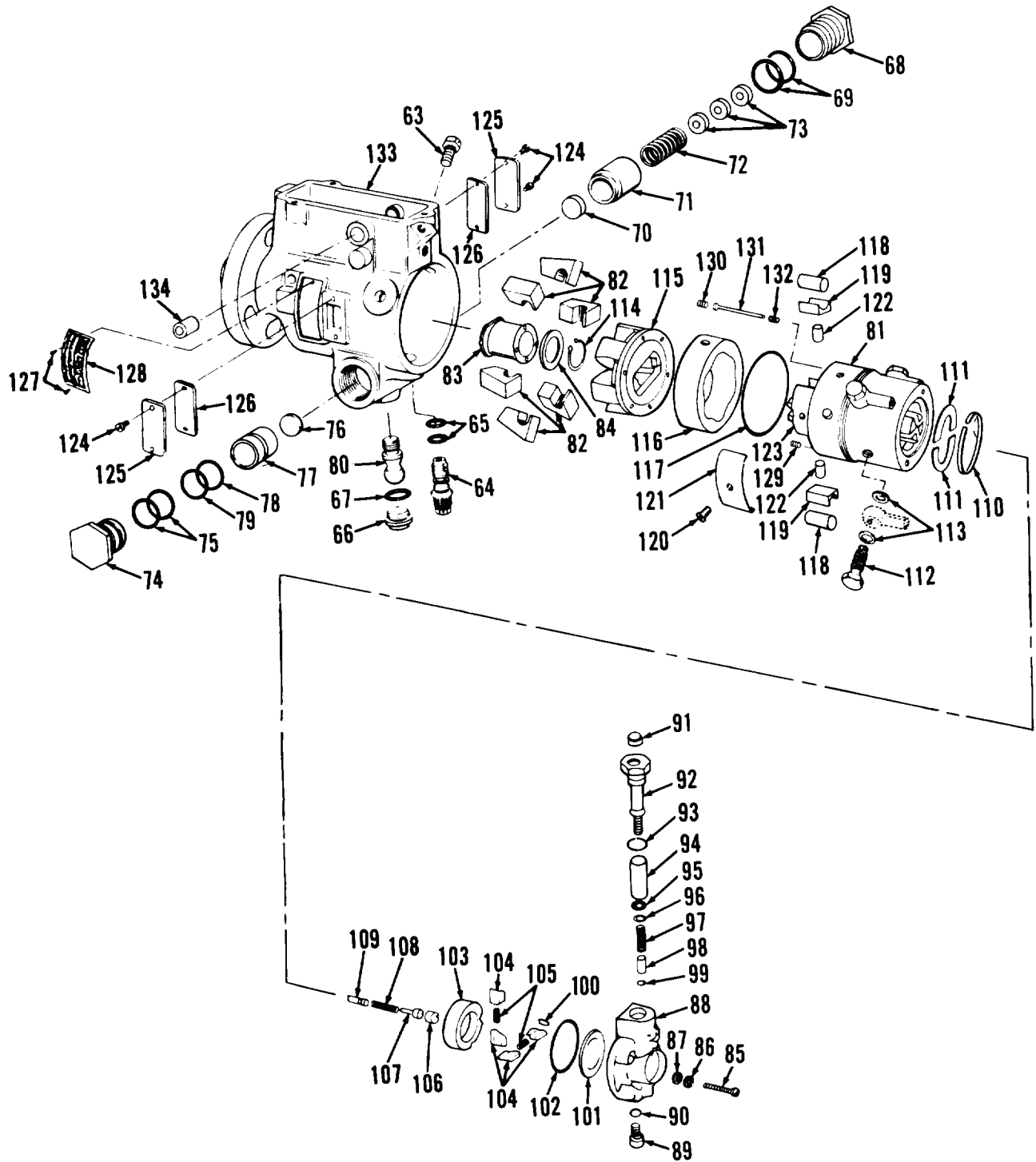

TA127274

Figure 7. Fuel Injection Pump Internal Components.

---

**DISASSEMBLY - CONTINUED****NOTE**

Do not remove rollpin unless sheared off or damaged.

63. At front of end plate (Figure 8, Item 88), remove rollpin (Figure 8, Item 100) if necessary. Use long nosed pliers or proper size drill.
64. Remove seal (Figure 8, Item 102) and thrust plate (Figure 8, Item 101). Discard seal.
65. At hydraulic head (Figure 8, Item 81), remove liner (Figure 8, Item 103), four transfer pump blades (Figure 8, Item 104), and two springs (Figure 8, Item 105).
66. Remove delivery valve screw (Figure 8, Item 106). Use socket setscrew wrench tool P/N 13316.

**NOTE**

If delivery valve sticks in its bore, use extractor tool P/N 13383 to remove.

67. Remove stop (Figure 8, Item 107), spring (Figure 8, Item 108), and delivery valve (Figure 8, Item 109). Lift hydraulic head (Figure 8, Item 81) and shake parts into your hand. If necessary, use extractor tool P/N 13383 to remove delivery valve.
68. Remove rotor retainer snap ring (Figure 8, Item 110). Use small blade screwdriver or dull scribe.
69. Remove two rotor retainers (Figure 8, Item 111). Move outward as far as possible to clear rotor and lift hydraulic head (Figure 8, Item 81) until rotor is flush with inner face of hydraulic head. Then, remove rotor retainers.

**CAUTION**

Rotor is no longer retained in hydraulic head. Do not let them slip apart when performing step 70.

70. Place hydraulic head (Figure 8, Item 81) in holding fixture tool P/N 19965.
71. Remove four fuel line connector screws (Figure 8, Item 112) and eight washers (Figure 8, Item 113).
72. At end of hydraulic head, remove retaining ring (Figure 8, Item 114). Use snap ring pliers tool P/N 13337.
73. Remove governor weight retainer (Figure 8, Item 115), cam ring (Figure 8, Item 116), and seal (Figure 8, Item 117) from hydraulic head (Figure 8, Item 81). Discard seal.



DISASSEMBLY - CONTINUED

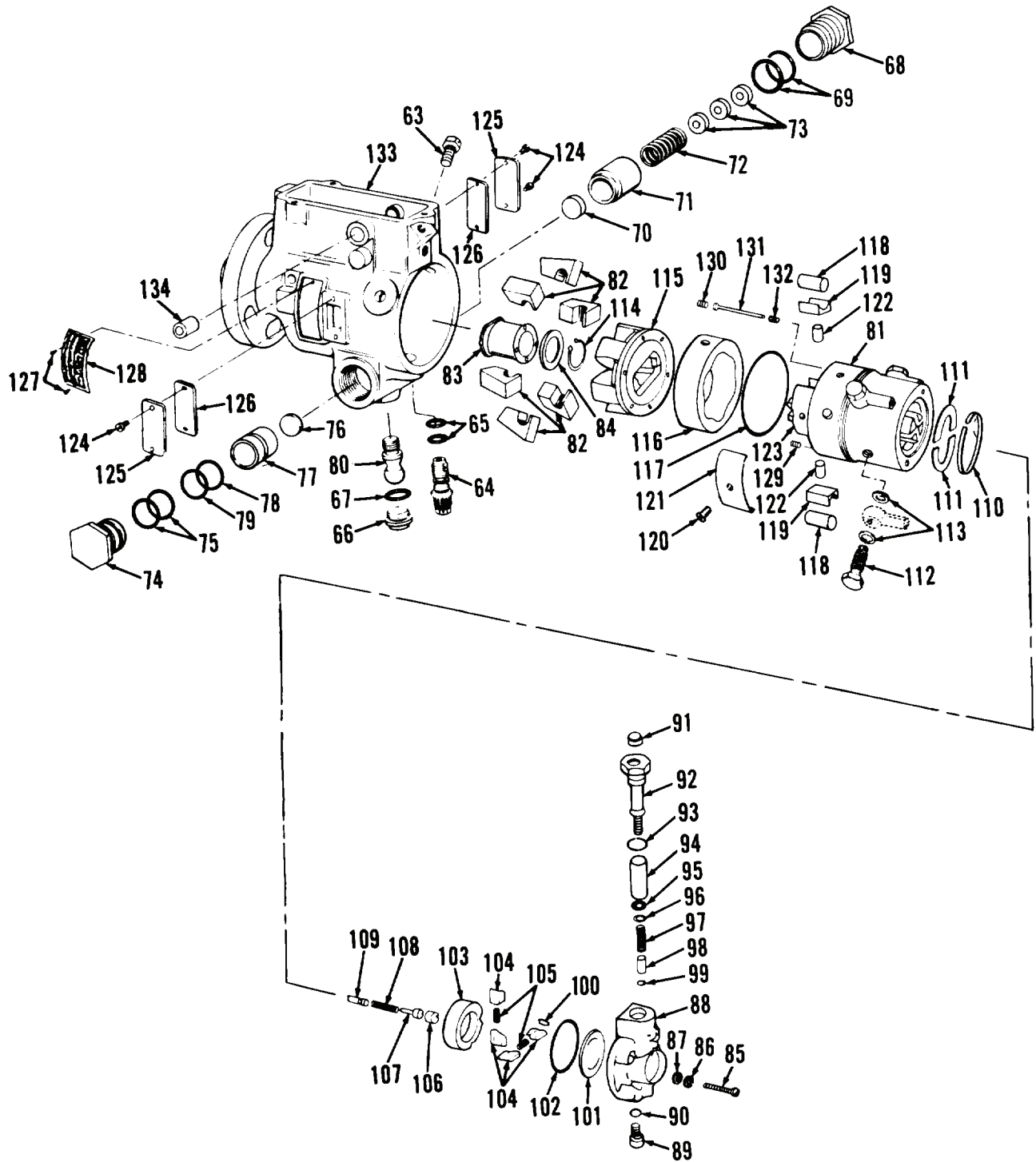

TA127274

Figure 8. Fuel Injection Pump Internal Components.

**DISASSEMBLY - CONTINUED****NOTE**

Perform steps 74 through 79 to check and record roller-to-roller dimension of cam rollers.

74. Install fixture tool P/N 19969 in vise.
75. Assemble 1/4-18 NPT fitting to fixture air inlet.

**WARNING**

Particles blown by compressed air are hazardous. DO NOT exceed 15 PSI (103 kPa) nozzle pressure when drying parts with compressed air. DO NOT exceed 30 PSI (207 kPa) nozzle pressure when cleaning parts with compressed air. DO NOT direct compressed air against human skin. Failure to follow this warning may result in injury to personnel. Make sure air stream is directed away from user and other personnel in the area. To prevent injury, user must wear protective goggles or face shield.

76. Adapt fitting to a 30 to 100 PSI (207 to 689 kPa) source of clean, dry air.

**CAUTION**

Handle hydraulic head carefully in step 77 and hold cam rollers and shoes in their slots to prevent rotor, cam rollers, and shoes from falling.

77. Install hydraulic head (Figure 10, Item 81) in fixture on air inlet side of fixture.
78. Rotate rotor until cam rollers (Figure 10, Item 118) are pushed to their extreme outward position by air pressure.
79. Use a 2-in. micrometer and measure cam roller-to-cam roller dimension as shown (Figure 9). Dimension must be  $1.965 \pm 0.015$  in. ( $49.91 \pm 0.38$  mm). Record dimension obtained.

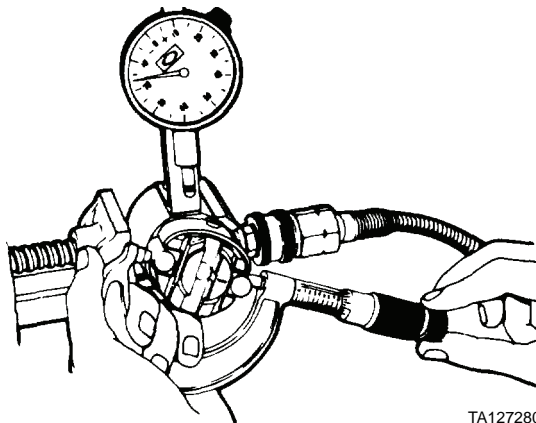

TA127280

**Figure 9. Measuring Across Rollers.**

**DISASSEMBLY - CONTINUED**

80. Remove hydraulic head (Figure 10, Item 81) from fixture and install in holding fixture tool P/N 19965.

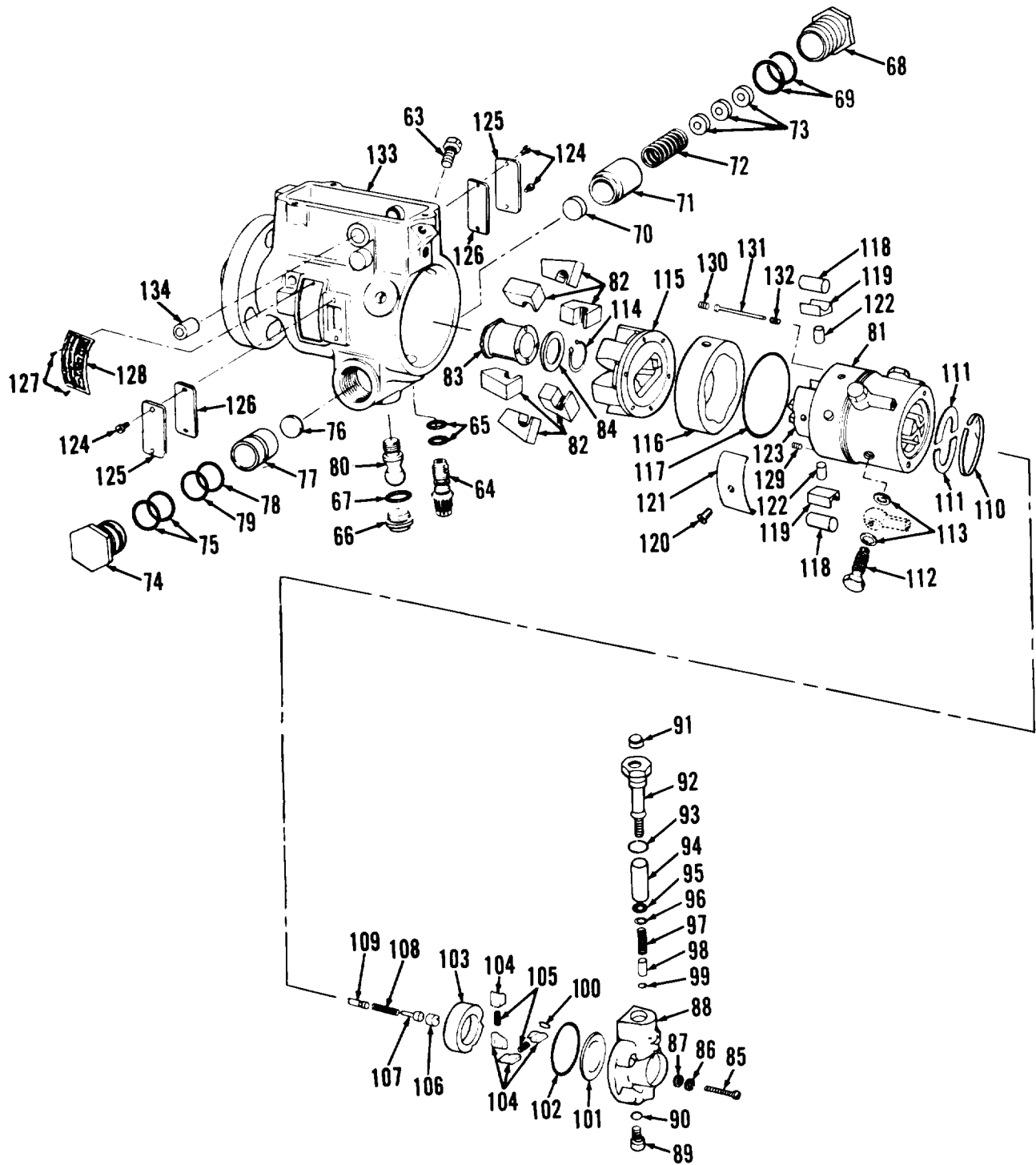

TA127274

**Figure 10. Fuel Injection Pump Internal Components.**

**DISASSEMBLY - CONTINUED**

81. Remove adjusting screw (Figure 12, Item 120) and leaf spring (Figure 12, Item 121). Use leaf spring adjusting screw-driver tool P/N 13336.

**CAUTION**

Handle parts in steps 82 and 83 carefully. Hands must be clean and wet with clean diesel fuel.

82. Remove two cam rollers (Figure 12, Item 118), cam roller shoes (Figure 12, Item 119), and pumping plungers (Figure 12, Item 122). Use extractor tool P/N 13301 as shown (Figure 11).

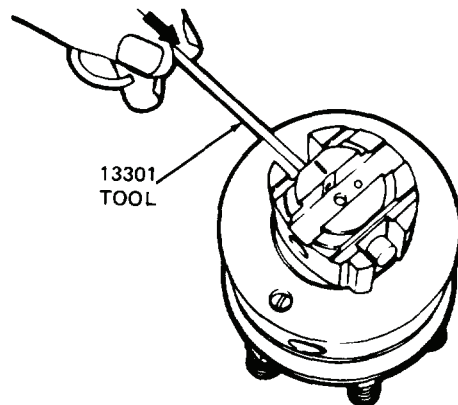

TA127281

**Figure 11. Removing Two Pumping Plungers.**

**CAUTION**

In step 83, do not handle shank of rotor.

83. Remove rotor (Figure 12, Item 123) from hydraulic head (Figure 12, Item 81).
84. At housing (Figure 12, Item 133), remove four screws (Figure 12, Item 124), two timing line covers (Figure 12, Item 125), and gaskets (Figure 12, Item 126). Discard gaskets.
85. Remove two screws (Figure 12, Item 127) and nameplate (Figure 12, Item 128), if necessary.
86. At hydraulic head (Figure 12, Item 81), remove plug screw (Figure 12, Item 129), if damaged.
87. Remove two plug screws (Figure 12, Item 130), if damaged.

**NOTE**

Do not perform steps 88 and 89 unless vent wire and vent wire retainer are damaged.

88. Remove vent wire retainer (Figure 12, Item 131) if damaged. Grasp hydraulic head (Figure 12, Item 81) in your hand and shake vent wire retainer into your other hand.
89. Remove vent wire (Figure 12, Item 132) if damaged. Use vent wire extractor tool P/N 18264.
90. At housing (Figure 12, Item 133), remove two bushings (Figure 12, Item 134), if damaged. Use proper size sleeve to press out bushings.

DISASSEMBLY - CONTINUED

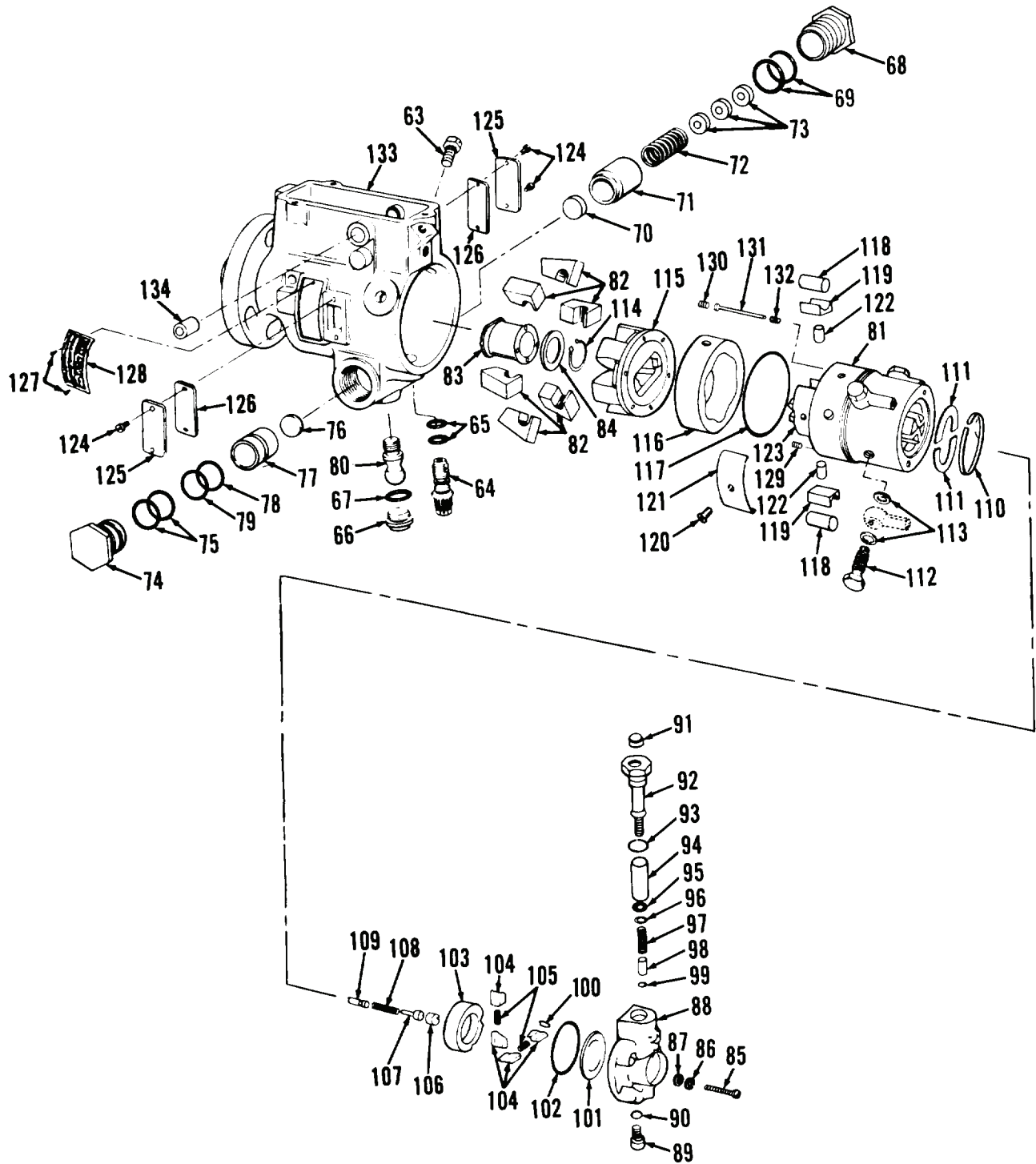

TA127274

Figure 12. Fuel Injection Pump Internal Components.

END OF TASK

**CLEANING****WARNING**

Solvent cleaning compound MIL-PRF-680 Type III is an environmentally compliant and low toxic material. However, it may be irritating to the eyes and skin. Use protective gloves and goggles. Use in well-ventilated areas. Keep away from open flames and other sources of ignition. Failure to do so may result in injury or death to personnel.

Clean all parts with solvent cleaning compound. Dry thoroughly.

**END OF TASK****INSPECTION**

1. Inspect housing for excessive wear, foreign material or rust, nicks or chipping, scratches or scores, thread damage, cracks, and distortion of seal seats, bores, and threads.
2. Inspect drive shaft for excessive wear, foreign material or rust, nicks or chipping, scratches or scores, thread damage, cracks, and distortion. Measure distance across flats of drive tang as shown (Figure 13); distance must not be less than 0.305 in. (7.75 mm). Shaft diameter in drive shaft seal area must be free of nicks and scratches. Moderate shaft wear from seal lips is normal.

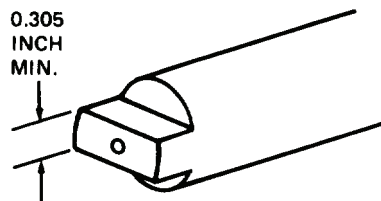

TA127282

**Figure 13. Measuring Drive Shaft.**

3. Inspect central and metering valve bores and ports of hydraulic head for excessive wear, foreign material or rust, nicks or chipping, scratches or scores, freedom of movement, thread damage, cracks, and distortion.

**WARNING**

Particles blown by compressed air are hazardous. DO NOT exceed 15 PSI (103 kPa) nozzle pressure when drying parts with compressed air. DO NOT exceed 30 PSI (207 kPa) nozzle pressure when cleaning parts with compressed air. DO NOT direct compressed air against human skin. Failure to follow this warning may result in injury to personnel. Make sure air stream is directed away from user and other personnel in the area. To prevent injury, user must wear protective goggles or face shield.

**INSPECTION - CONTINUED**

4. Inspect vent wire and vent wire retainer for foreign material and rust. Check vent wire for freedom of movement. If wire is free, flush head and blow out all passages with clean, dry air as shown (Figure 14). If wire is stuck in screw, remove and replace after a thorough cleaning of the unit and hydraulic head passage.

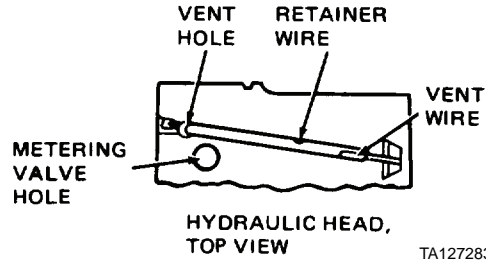

**Figure 14. Checking Condition of Vent Wire.**

5. Inspect rotor for excessive wear, foreign material or rust, nicks or chipping, scratches or scores, and freedom of movement. Check radii contacted by leaf spring and tang slot for excessive wear. Check all slots, charging, and discharge ports for chipping of edges or dirt and rotor shank for scratches. If damage or excessive wear is apparent, replace head and rotor as a (matched) unit.
6. Inspect delivery valve and delivery valve spring for excessive wear, foreign material or rust, nicks or chipping, scratches or scores, freedom of movement, and distortion. Check retraction cuff for chipping or erosion of edges.



Solvent cleaning compound MIL-PRF-680 Type III is an environmentally compliant and low toxic material. However, it may be irritating to the eyes and skin. Use protective gloves and goggles. Use in well-ventilated areas. Keep away from open flames and other sources of ignition. Failure to do so may result in injury or death to personnel.

**CAUTION**

Do not force plungers into the bores and do not handle rotor shank.

7. Inspect pumping plungers for excessive wear, foreign material or rust, nicks or chipping, scratches or scores, and freedom of movement. Hold rotor under clean oil and insert plungers into their bore. With your thumb and forefinger over shoe slots, tilt from side to side several times to determine complete freedom of movement as shown (Figure 15). Reversing or interchanging initial positions may be necessary as these are matched parts. If plungers are sticking, but not visibly damaged, clean both plungers and bore with a soft brush and solvent cleaning compound.

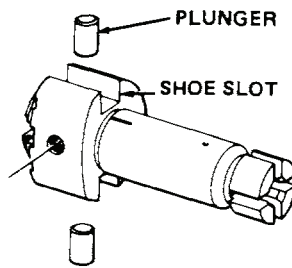

**Figure 15. Checking Pumping Plungers for Freedom of Movement.**

**INSPECTION - CONTINUED**

8. Inspect cam rollers and shoes. Check each roller in its shoe for freedom of rotation. Inspect top edge of each shoe, where retained by leaf spring, for chipping or excessive wear. Inspect for abrasive wear patterns as shown (Figure 16).

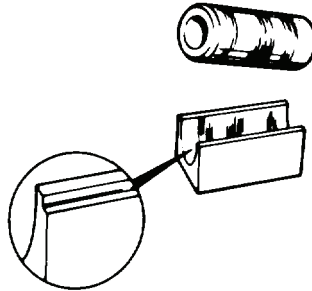

TA127286

**Figure 16. Checking Cam Rollers for Freedom of Rotation.**

9. Inspect leaf spring and screws for excessive wear, foreign material or rust, nicks or chipping, thread damage, cracks, and distortion. Check for excessive wear at points where spring contacts the radii on rotor and along steps that retain roller shoes as shown (Figure 17). Check adjusting screw for tightness in rotor.

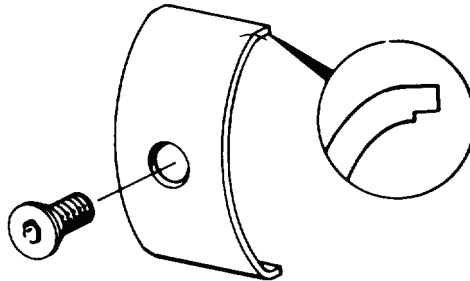

TA127287

**Figure 17. Checking Leaf Spring for Wear.**

10. Inspect cam ring for excessive wear, foreign material or rust, nicks or chipping, scratches or scores, cracks, and distortion. Tool marks between lobes should not be considered damage. Mottled appearance of cam is from heat treatment, not from operation. Inspect cam lobes and edges of all flat surfaces. If evidence of spalling or flaking out (Figure 18), replace.

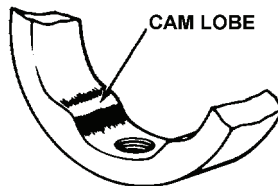

TA127288

**Figure 18. Inspecting Cam Ring.**

11. Inspect governor weight retainer for excessive wear, foreign material or rust, nicks or chipping, cracks, and distortion. Check weight pivot area and ring area for wear.



**INSPECTION - CONTINUED**

12. Inspect governor weights for excessive wear, foreign material or rust, nicks or chipping, freedom of movement, and cracks. Check pivot points (heel and toe) for excessive wear as shown (Figure 19).

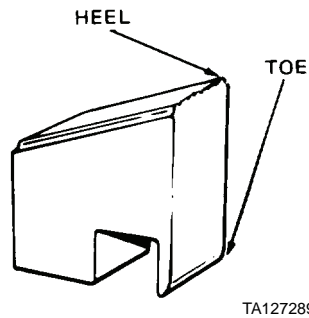

**Figure 19. Checking Governor Weights for Wear.**

13. Inspect governor thrust washer for excessive wear, foreign material or rust, nicks or chipping, scratches or scores, cracks, and distortion. Check contact area for excessive wear.
14. Inspect governor thrust sleeve for excessive wear, foreign material or rust, nicks or chipping, scratches or scores, cracks, and distortion. Check points of contact with governor arm for excessive wear.
15. Inspect blades of transfer pump for excessive wear, nicks or chipping, scratches or scores, and cracks. Check for chipping on all edges, including spring bore edges for pitting, imbedded foreign particles or scoring on rounded edges. Determine blade wear by measuring length (0.538 in. [13.67 mm] minimum). Inspect flat surfaces visually for deep scores as shown (Figure 20). If any discrepancies are noted, replace blade sets and spring.

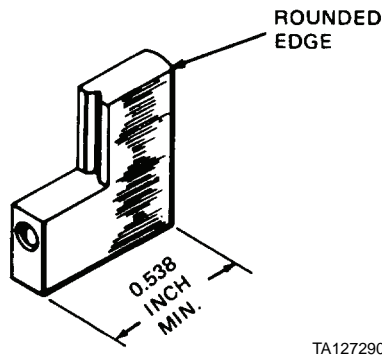

**Figure 20. Measuring Transfer Pump Blades for Wear.**

16. Inspect inside diameter in low pressure area of liner for excessive wear, foreign material or rust, nicks or chipping, and scratches or scores.
17. Inspect governor pivot shaft for excessive wear, foreign material or rust, nicks or chipping, freedom of movement, and distortion.
18. Inspect governor arm for excessive wear at points of contact with thrust sleeve and pivot shaft, foreign material or rust, nicks or chipping, cracks, and distortion.
19. Inspect metering valve for excessive wear at contact area of body, foreign material or rust, nicks or chipping, scratches or scores, freedom of movement, and cracks.
20. Inspect metering valve arm for excessive wear, foreign material, nicks or chipping, scratches or scores, cracks, and distortion. Check pin of metering valve for wear and looseness.

**INSPECTION - CONTINUED**

21. Inspect linkage hook, including metering valve pin hole, for excessive wear, foreign material or rust, nicks or chipping, thread damage, cracks, and distortion.
22. Inspect pistons for excessive wear, foreign material or rust, nicks or chipping, scratches or scores, and freedom of movement.
23. Inspect cam advance screw for excessive wear, foreign material or rust, nicks or chipping, scratches or scores, freedom of movement, thread damage, and cracks.
24. Inspect plugs for excessive wear, foreign material or rust, nicks or chipping, scratches or scores, freedom of movement, thread damage, cracks, and distortion.
25. Inspect head-locating screw, including orifice, for foreign materials, nicks or chipping, scratches or scores, thread damage, and cracks.
26. Inspect sleeve of end plate for foreign material or rust. Check bypass port for clogging.
27. Inspect upper end of regulating piston for excessive wear, foreign material or rust, nicks or chipping, scratches or scores, and freedom of movement.
28. Inspect end plate for excessive wear from transfer pump end thrust, foreign material or rust, scratches or scores, thread damage, and distortion.
29. Inspect bottom surface of end plate plug for excessive wear and thread damage.
30. Inspect regulator spring for distortion. Free length should be 0.633 to 0.667 in. (16.08 to 16.94 mm), rate of compression 10 lb per in. (4.5 kg per 25.4 mm).
31. Inspect solenoid frame and arm assembly for cracks and distortion in encapsulating material and looseness of screw terminals. Use ohmmeter and check for continuity. Replace if any defects observed or if continuity is not obtained.

**END OF TASK****ASSEMBLY****WARNING**

DO NOT smoke or permit any open flame in area of machine while you are servicing fuel system. Failure to follow this warning may result in injury or death to personnel, or damage to equipment.

**NOTE**

All parts must be flushed in clean diesel fuel as they are assembled.

1. Install vent wire (Figure 21, Item 132) in vent wire retainer (Figure 21, Item 131) if removed.
2. Install vent wire retainer (Figure 21, Item 131) in hydraulic head (Figure 21, Item 81) if removed.
3. Install two plug screws (Figure 21, Item 130) and plug screw (Figure 21, Item 129) in hydraulic head (Figure 21, Item 81).
4. At housing (Figure 21, Item 133), install nameplate (Figure 21, Item 128) on housing with two screws (Figure 21, Item 127) if removed.
5. Install two bushings (Figure 21, Item 134) on hydraulic head (Figure 21, Item 81), if removed. Use soft hammer to install.
6. Install new seal (Figure 21, Item 93) and filter element (Figure 21, Item 94) on sleeve (Figure 21, Item 92).
7. Install new seal (Figure 21, Item 95) and new O-ring (Figure 21, Item 96) on sleeve (Figure 21, Item 92).
8. Install regulator spring (Figure 21, Item 97) and regulating piston (Figure 21, Item 98) in sleeve (Figure 21, Item 92).
9. Install new seal (Figure 21, Item 99) on regulating piston (Figure 21, Item 98).
10. Install sleeve (Figure 21, Item 92) in end plate (Figure 21, Item 88). Be careful not to disturb parts assembled to sleeve. Finger-tighten sleeve in end plate.
11. Install plug (Figure 21, Item 91) in sleeve (Figure 21, Item 92).
12. At bottom of end plate, install new seal (Figure 21, Item 90) and plug (Figure 21, Item 89).

ASSEMBLY - CONTINUED

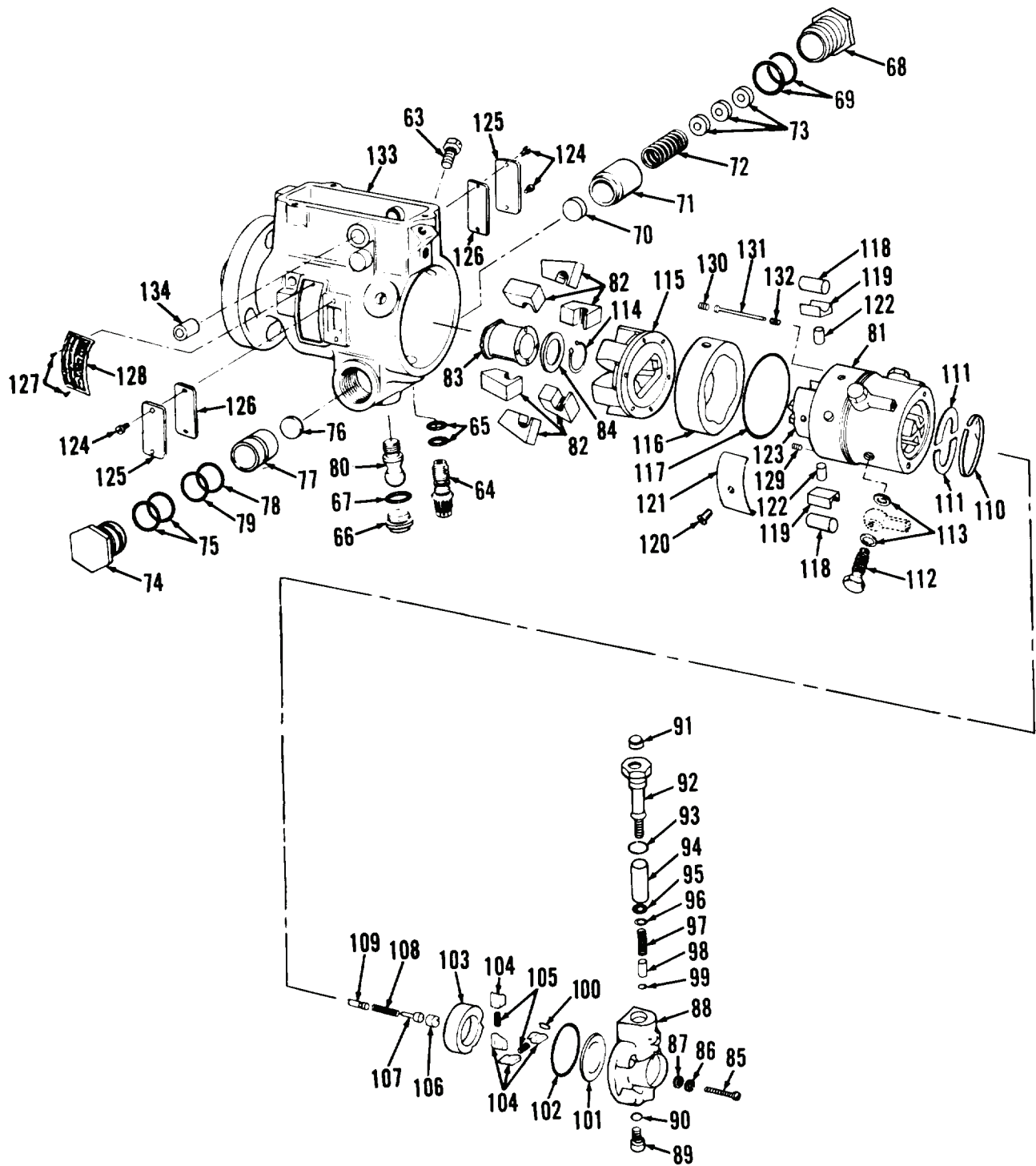

Figure 21. Fuel Injection Pump Internal Components.

TA127274

**ASSEMBLY - CONTINUED****NOTE**

Pumping plungers are graded in four sizes A through D in either standard or oversize. The correct grading letter is etched on the rotor base; if a “-2” is also etched on rotor base, this indicates an oversize pumping plunger is required. Absence of a “-2” indicates a standard size plunger in either size A through D, as etched on rotor base, is required.

13. At hydraulic head (Figure 22, Item 81), install two pumping plungers (Figure 22, Item 122) in rotor bores with chamfers facing inward.
14. Flush rotor (Figure 22, Item 123) thoroughly in clean diesel fuel. Do not handle rotor shank. Keep your fingers over plungers to stop them from falling out.
15. Flush hydraulic head (Figure 22, Item 81) thoroughly in clean diesel fuel and install rotor (Figure 22, Item 123) into hydraulic head (Figure 22, Item 81) using slight rotary motion while both are immersed in clean diesel fuel.
16. Install hydraulic head (Figure 22, Item 81) and rotor (Figure 22, Item 123) in holding fixture tool P/N 19965.
17. Install leaf spring (Figure 22, Item 121) with adjusting screw (Figure 22, Item 120). Use leaf spring adjusting screwdriver tool P/N 13336.
18. Install two cam roller shoes (Figure 22, Item 119) and cam rollers (Figure 22, Item 118) in rotor (Figure 22, Item 123), then check to ensure freedom of movement.

**NOTE**

Perform steps 19 through 24 to check and adjust cam roller-to-cam roller dimension.

19. Install fixture tool P/N 19969 in vise.
20. Install a 1/4-18 NPT fitting on air inlet of fixture.

**WARNING**

Particles blown by compressed air are hazardous. DO NOT exceed 15 PSI (103 kPa) nozzle pressure when drying parts with compressed air. DO NOT exceed 30 PSI (207 kPa) nozzle pressure when cleaning parts with compressed air. DO NOT direct compressed air against human skin. Failure to follow this warning may result in injury to personnel. Make sure air stream is directed away from user and other personnel in the area. To prevent injury, user must wear protective goggles or face shield.

21. Adapt fitting to a 30 to 100 PSI (207 to 689 kPa) source of clean, dry air.

**CAUTION**

Handle hydraulic head carefully in step 22 and hold cam rollers and shoes in their slots to prevent rotor, cam rollers, and shoes from falling.

22. Install hydraulic head (Figure 22, Item 81) in fixture on air inlet side of fixture.
23. Rotate rotor until cam rollers (Figure 22, Item 118) are pushed to their extreme outward position by air pressure.

ASSEMBLY - CONTINUED

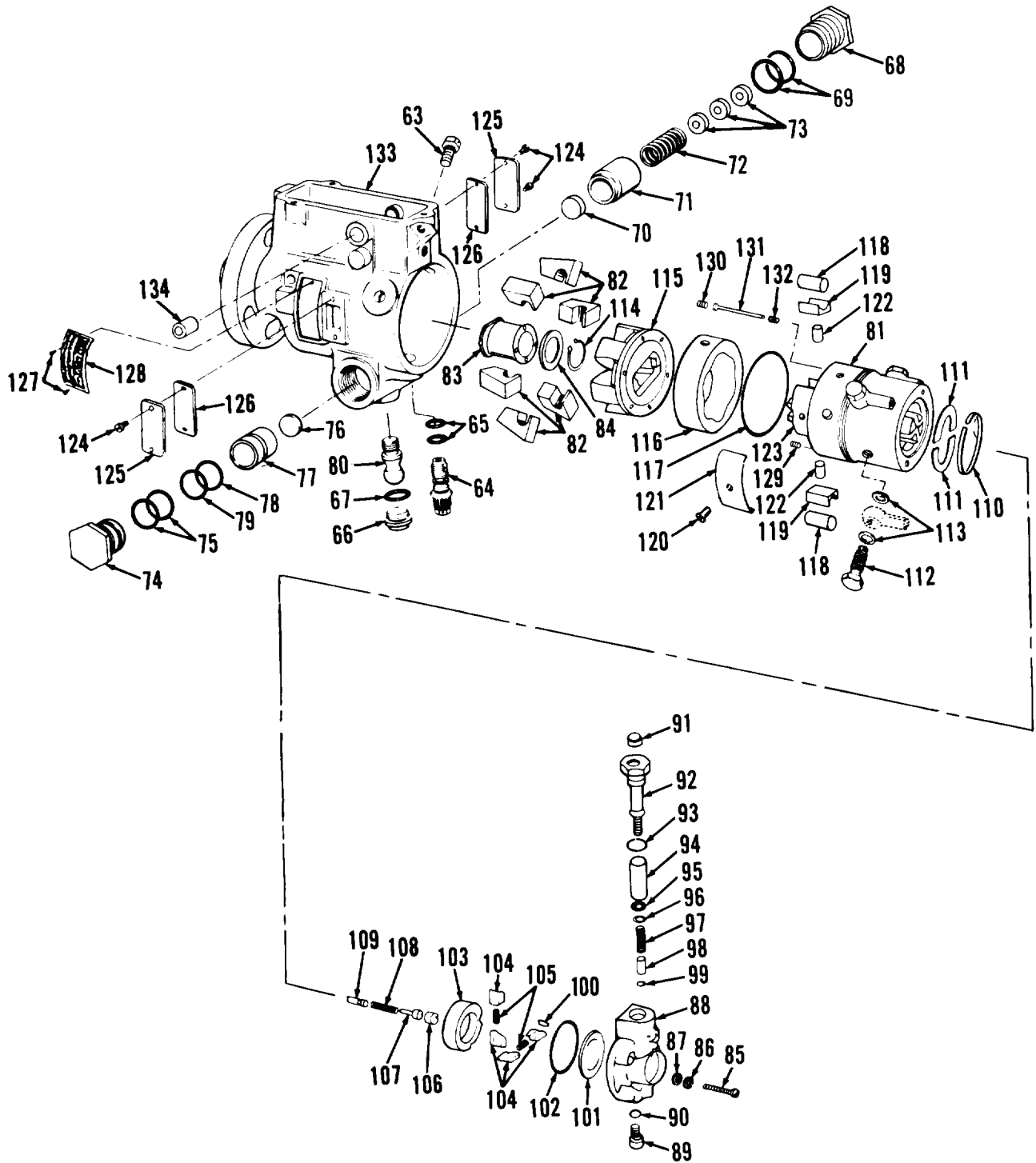
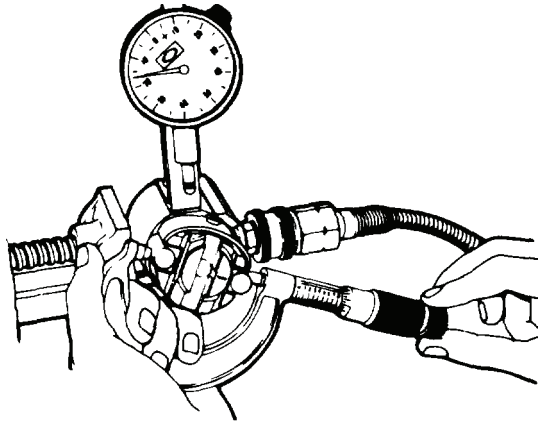

Figure 22. Fuel Injection Pump Internal Components.

TA127274

**ASSEMBLY - CONTINUED**

24. Use a 2-in. micrometer and measure cam roller-to-cam roller dimension as shown (Figure 23). Dimension must be  $1.965 \pm 0.0015$  in. ( $49.91 \pm 0.38$  mm); if necessary, turn adjusting screw (Figure 24, Item 120) clockwise to decrease travel.



TA127280

**Figure 23. Measuring Across Rollers.**

25. Remove hydraulic head from fixture and install in holding fixture tool P/N 19965.
26. Position cam ring (Figure 24, Item 116) on hydraulic head with directional arrow facing upward.
27. Install governor weight retainer (Figure 24, Item 115). Align mark on governor weight retainer with mark on rotor (Figure 24, Item 123).
28. Install retaining ring (Figure 24, Item 114). Ensure retaining ring is fully installed in its groove.
29. Invert hydraulic head (Figure 24, Item 81) in holding fixture. Be sure governor weight retainer (Figure 24, Item 115) engages bar on holding fixture.

ASSEMBLY - CONTINUED

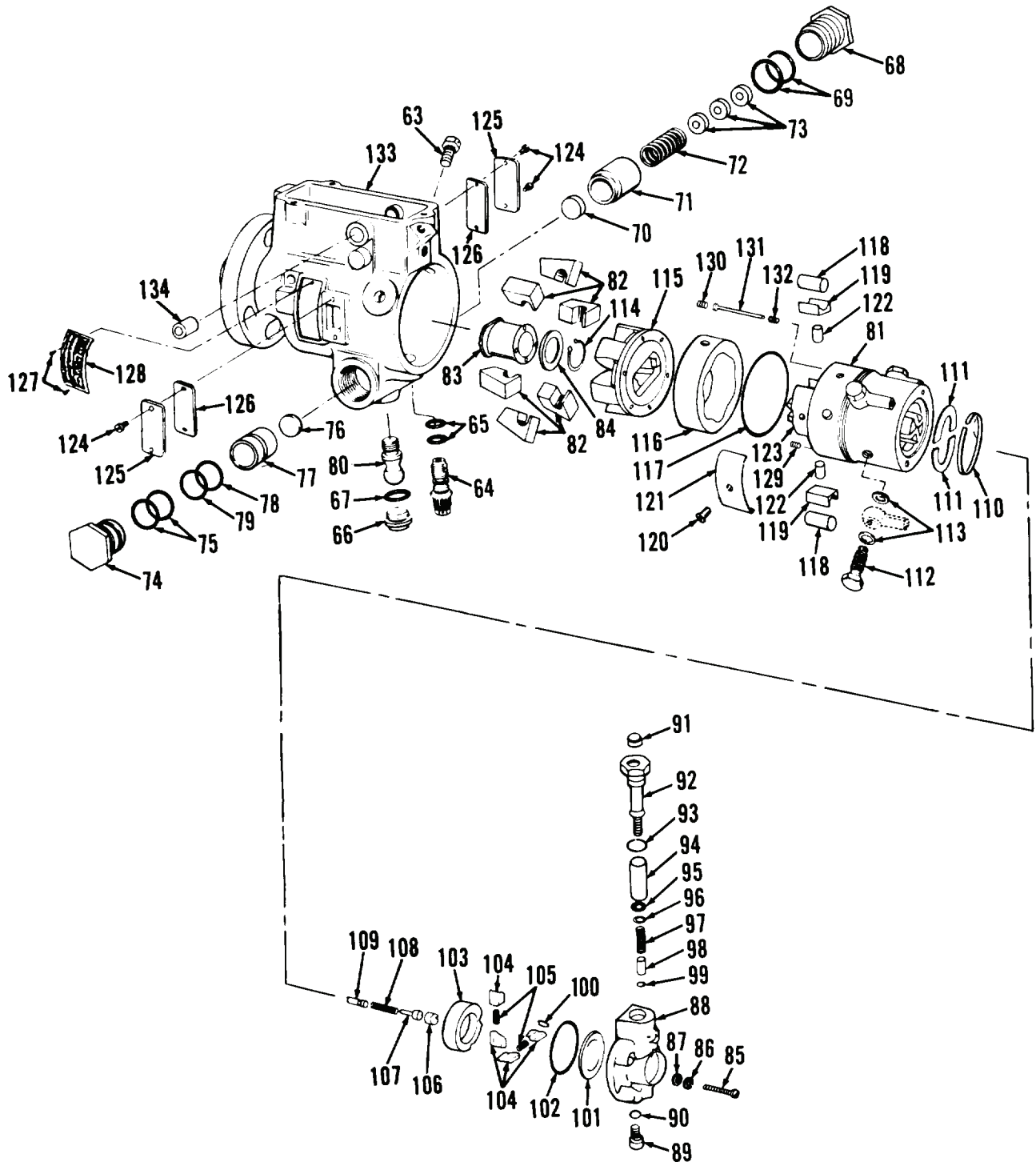

TA127274

Figure 24. Fuel Injection Pump Internal Components.

**ASSEMBLY - CONTINUED****NOTE**

Delivery valves are supplied in standard size and oversize. The size used is etched on rotor.

30. Install delivery valve (Figure 25, Item 109) in hydraulic head (Figure 25, Item 81). Ensure it operates freely in its bore.
31. Install spring (Figure 25, Item 108), new stop (Figure 25, Item 107), and delivery valve screw (Figure 25, Item 106) with relieved end facing down. Use extractor tool P/N 13383 and tighten screw to 85 to 90 lb-in. (9.6 to 10.2 Nm).
32. Install two rotor retainers (Figure 25, Item 111). Lift hydraulic head up until inside face of head is flush with rotor end, then position with outer sleeve of rotor retaining ring installation tool P/N 13375.
33. Install snap ring (Figure 25, Item 110).
34. Install liner (Figure 25, Item 103) so large slot is in line with head-locating screw hole and marking indicating pump rotation is facing upward.

**NOTE**

Some rotors have oversized blade slots (0.001 in. [0.03 mm] wider than normal). Pump blades are furnished in standard size and oversize. Always install oversized pump blades first. If oversized pump blades fit any of the slots, they should be used in those slots. Both oversize and standard size pump blades may be used in the same rotor.

35. Install four pump blades (Figure 25, Item 104) and two springs (Figure 25, Item 105) into rotor (Figure 25, Item 123). Rotate liner several times to check for binding; remove and reinstall blades and springs, if binding is detected. Position liner in correct position as indicated in preceding note.
36. Install new seal (Figure 25, Item 102) and thrust plate (Figure 25, Item 101) on end plate (Figure 25, Item 88).
37. Install new roll pin (Figure 25, Item 100) in end plate, if removed.

**NOTE**

If rollpin in end plate and locating slot in liner are 180 degrees out of alignment, ensure rollpin is installed in its proper location as to pump rotation (C and CC are marked on outside of end plate).

38. Position hydraulic head (Figure 25, Item 81) on end plate (Figure 25, Item 88).
39. Install four washers (Figure 25, Item 87), new lockwashers (Figure 25, Item 86), and screws (Figure 25, Item 85). Tighten screws to 25 to 30 lb-in. (2.8 to 3.4 Nm).
40. Position hydraulic head (Figure 25, Item 81) and rotor (Figure 25, Item 123) with drive end up.
41. Position six governor weights (Figure 25, Item 82) in sockets of rotor (Figure 25, Item 123) so slots face bore of hydraulic head and rotor assembly.
42. Position thrust washer (Figure 25, Item 84) against thrust sleeve (Figure 25, Item 83) with chamfered edge facing thrust sleeve.
43. Install thrust sleeve (Figure 25, Item 83) with tab facing upward. Insert your forefinger into bore of thrust sleeve and thrust washer (Figure 25, Item 84) to hold them together and insert into slots of governor weights (Figure 25, Item 82) by tilting weights back slightly.
44. Check position of six governor weights (Figure 25, Item 82). Sight across tops of assembled weights to check positioning. One weight higher than others indicates incorrect assembly of thrust washer (Figure 25, Item 84). Disassemble and repeat steps 41 through 44.
45. Position governor arm (Figure 25, Item 56) so fork for linkage hook (Figure 25, Item 54) faces end plate (Figure 25, Item 88).
46. Install governor arm pivot shaft (Figure 25, Item 60) on housing (Figure 25, Item 133) with knife edge facing end plate (Figure 25, Item 88).



ASSEMBLY - CONTINUED

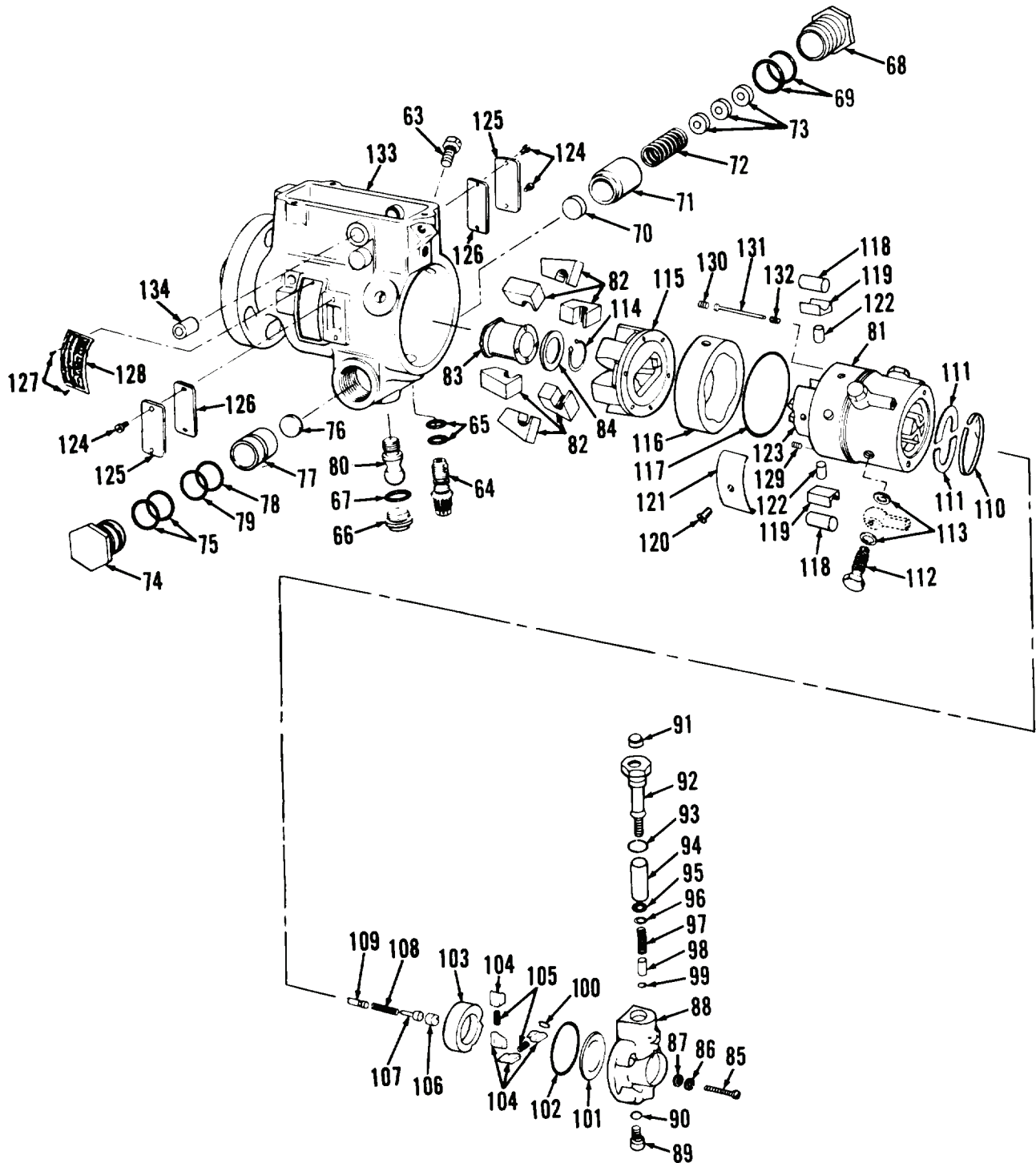

Figure 25. Fuel Injection Pump Internal Components.

TA127274

**ASSEMBLY - CONTINUED**

47. Install two new seals (Figure 26, Item 59) and pivot shaft nuts (Figure 26, Item 58). Tighten nuts to 20 to 25 lb-in. (2.3 to 2.8 Nm).
48. Install new seal (Figure 26, Item 117) on hydraulic head (Figure 26, Item 81).
49. Apply light film of clean grease around inside edge of housing (Figure 26, Item 133).

**CAUTION**

If, during step 50, the hydraulic head and rotor should cock during installation, withdraw it and start over. Failure to do so could cause particles of metal to be shaved off and left in the housing, causing serious damage during operation. Be careful not to insert hydraulic head too far into housing; seal may be damaged and result in leakage.

50. Install hydraulic head (Figure 26, Item 81) and rotor (Figure 26, Item 123) in housing (Figure 26, Item 133). Rotate cam ring (Figure 26, Item 116) so unthreaded hole is in line with metering valve bore in housing. Grasp head firmly in both hands and insert into housing bore with a slight rotary motion. Do not force this operation.
51. Align head-locking screw holes in hydraulic head (Figure 26, Item 81) and housing (Figure 26, Item 133) by rotating hydraulic head (Figure 26, Item 81).
52. Install two head-locking screws (Figure 26, Item 63) finger tight.

**NOTE**

Perform step 53 to prevent governor weights from dislodging.

53. Install drive shaft in fuel injection pump.
54. Invert fuel injection pump and fixture in vise so bottom faces upward.
55. Install two new seals (Figure 26, Item 65) on head-locating screw (Figure 26, Item 64).
56. Install head-locating screw (Figure 26, Item 64) in housing (Figure 26, Item 133). Tighten screw to 180 to 220 lb-in. (20.3 to 24.8 Nm).
57. Install cam advance screw (Figure 26, Item 80). Use tools P/Ns 15499 and 15500. Tighten screw to 440 to 460 lb-in. (49.7 to 51.9 Nm).
58. Install new seal (Figure 26, Item 78) and piston ring (Figure 26, Item 79) in grooves of power piston (Figure 26, Item 77).
59. Install two new seals (Figure 26, Item 69) in grooves of advance piston hole plug (Figure 26, Item 68).
60. Install two new seals (Figure 26, Item 75) in grooves of power piston hole plug (Figure 26, Item 74).
61. Position shims (Figure 26, Item 73) on advance adjusting spring (Figure 26, Item 72). Use small amount of grease to hold in position.
62. Install advance adjusting spring (Figure 26, Item 72) in piston (Figure 26, Item 71).
63. Install piston (Figure 26, Item 71) into advance piston hole plug (Figure 26, Item 68).
64. Position slide washer (Figure 26, Item 70) on piston (Figure 26, Item 71). Use small amount of grease to hold in position.
65. Install advance piston hole plug (Figure 26, Item 68) to housing (Figure 26, Item 133). Finger tighten.
66. Install power piston (Figure 26, Item 77) on power piston hole plug (Figure 26, Item 74). Use piston ring compressor tool P/N 16199.
67. Install slide washer (Figure 26, Item 76) on power piston (Figure 26, Item 77). Use small amount of grease to hold in position.

ASSEMBLY - CONTINUED

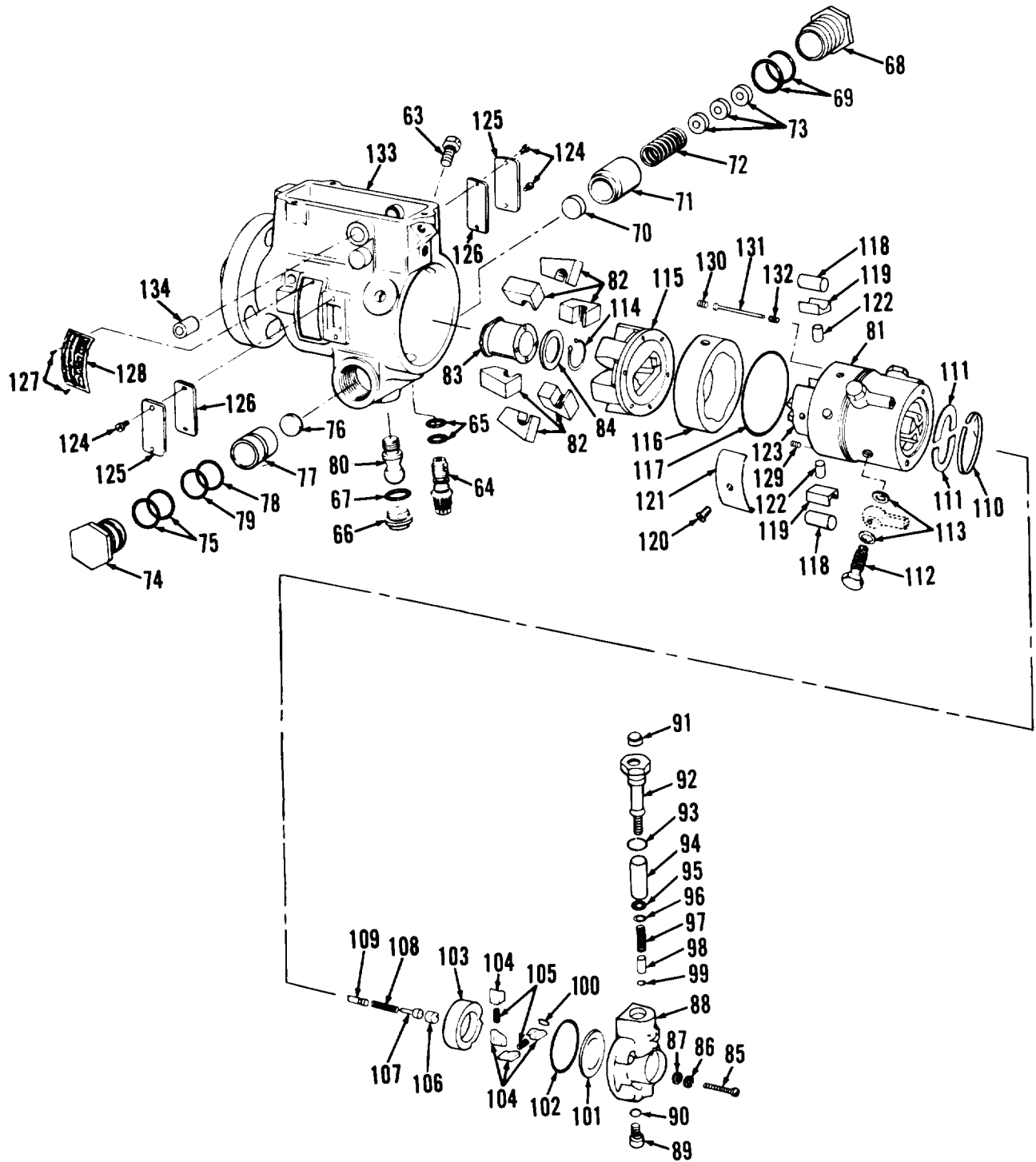

Figure 26. Fuel Injection Pump Internal Components.

TA127274

---

**ASSEMBLY - CONTINUED****NOTE**

Power piston hole plug and power piston are installed in side of housing marked C for a clockwise rotating pump.

68. Install power piston hole plug (Figure 27, Item 74) in housing (Figure 27, Item 133). Finger tighten.
69. Install new seal (Figure 27, Item 67) on advance screw hole plug (Figure 27, Item 66).
70. Install advance screw hole plug (Figure 27, Item 66) in housing (Figure 27, Item 133). Tighten plug to 180 to 220 lb-in. (20.3 to 24.8 Nm) using advance plug tool P/N 14490.
71. Tighten advance piston hole plug (Figure 27, Item 68) and power piston hole plug (Figure 27, Item 74) to 215 to 265 lb-in. (24.3 to 29.9 Nm).

ASSEMBLY - CONTINUED

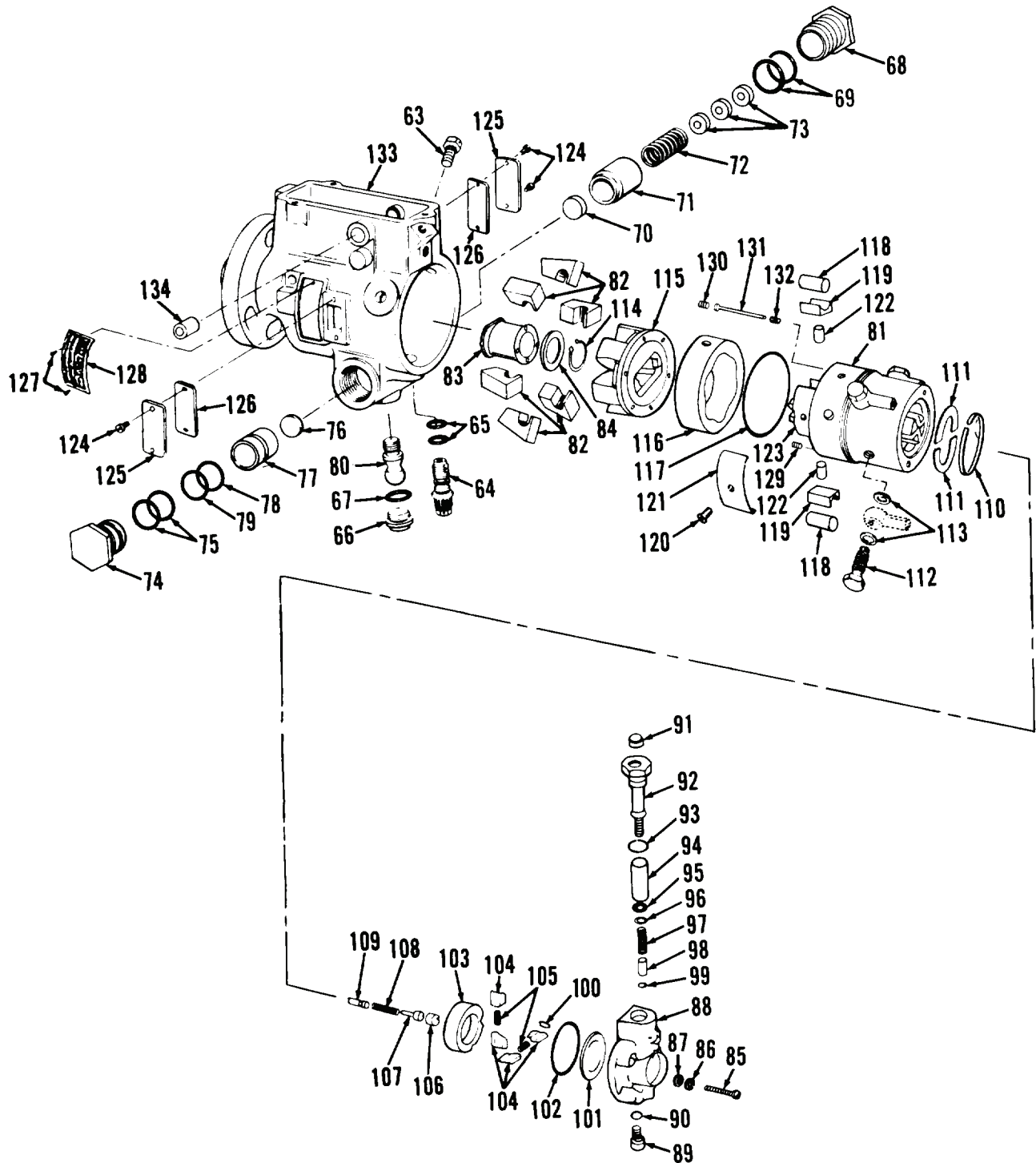

TA127274

Figure 27. Fuel Injection Pump Internal Components.

**ASSEMBLY - CONTINUED****NOTE**

Metering valve is furnished in two sizes: A and B. If original valve has a ring groove cut just below shouldered top crown, order size B for replacement; otherwise, order size A.

72. Position shim (Figure 30, Item 61) on metering valve (Figure 30, Item 53).
73. Install metering valve arm (Figure 30, Item 55) on metering valve (Figure 30, Item 53) as shown (Figure 28). Use soft hammer.

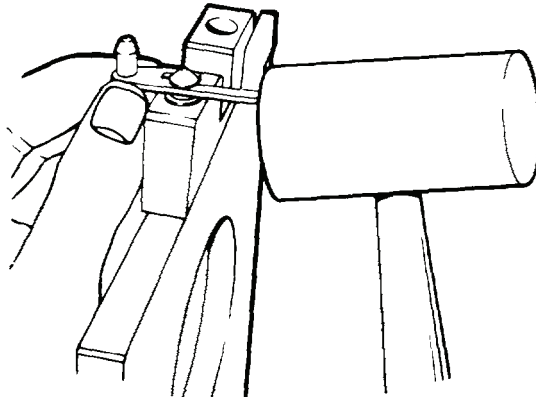

TA127273

**Figure 28. Metering Valve Arm and Shim.**

74. Install spring (Figure 30, Item 62) on metering valve (Figure 30, Item 53).
75. Install metering valve (Figure 30, Item 53), shim (Figure 30, Item 61), metering valve arm (Figure 30, Item 55), and spring (Figure 30, Item 62) in bore of housing (Figure 30, Item 133) as shown (Figure 29). Depress and rotate several times to ensure freedom of movement. If valve sticks, lap it with clean diesel fuel.

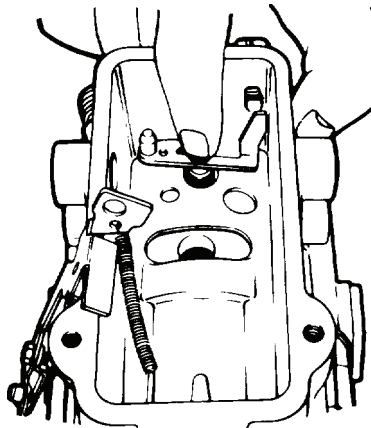

TA127291

**Figure 29. Installing Metering Valve Components.**

ASSEMBLY - CONTINUED

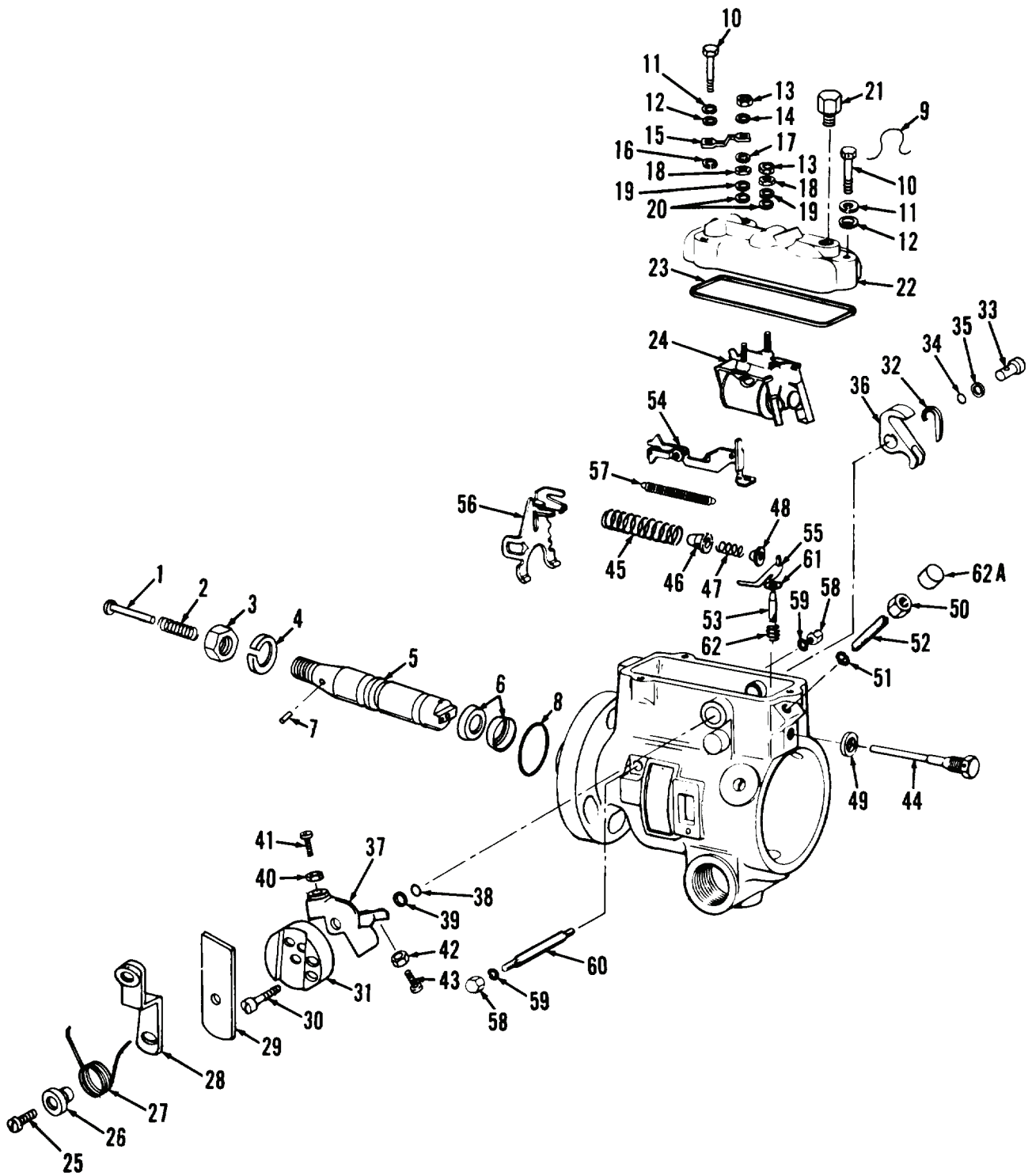
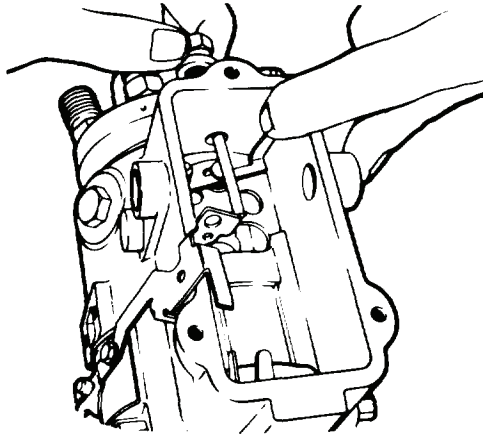

Figure 30. Fuel Injection Pump External Components.

TA127268

**ASSEMBLY - CONTINUED**

76. Position washer (Figure 33, Item 49) on guide stud (Figure 33, Item 44).
77. Depress metering valve (Figure 33, Item 53) and install guide stud (Figure 33, Item 44) as shown (Figure 31). Finger tighten guide stud.



TA127292

**Figure 31. Installing Washer and Guide Stud.**

78. Pull back linkage hook while stretching spring (Figure 33, Item 57) just enough to assemble linkage (Figure 33, Item 54) hook correctly on fork of governor arm (Figure 33, Item 56) as shown (Figure 32). Position opposite end of hook over pin on metering valve arm (Figure 33, Item 55). Check all parts for freedom of movement.
79. Install governor arm (Figure 33, Item 56).

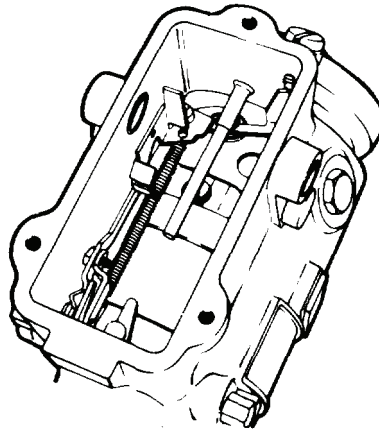

TA127293

**Figure 32. Installing Linkage Components.**



ASSEMBLY - CONTINUED

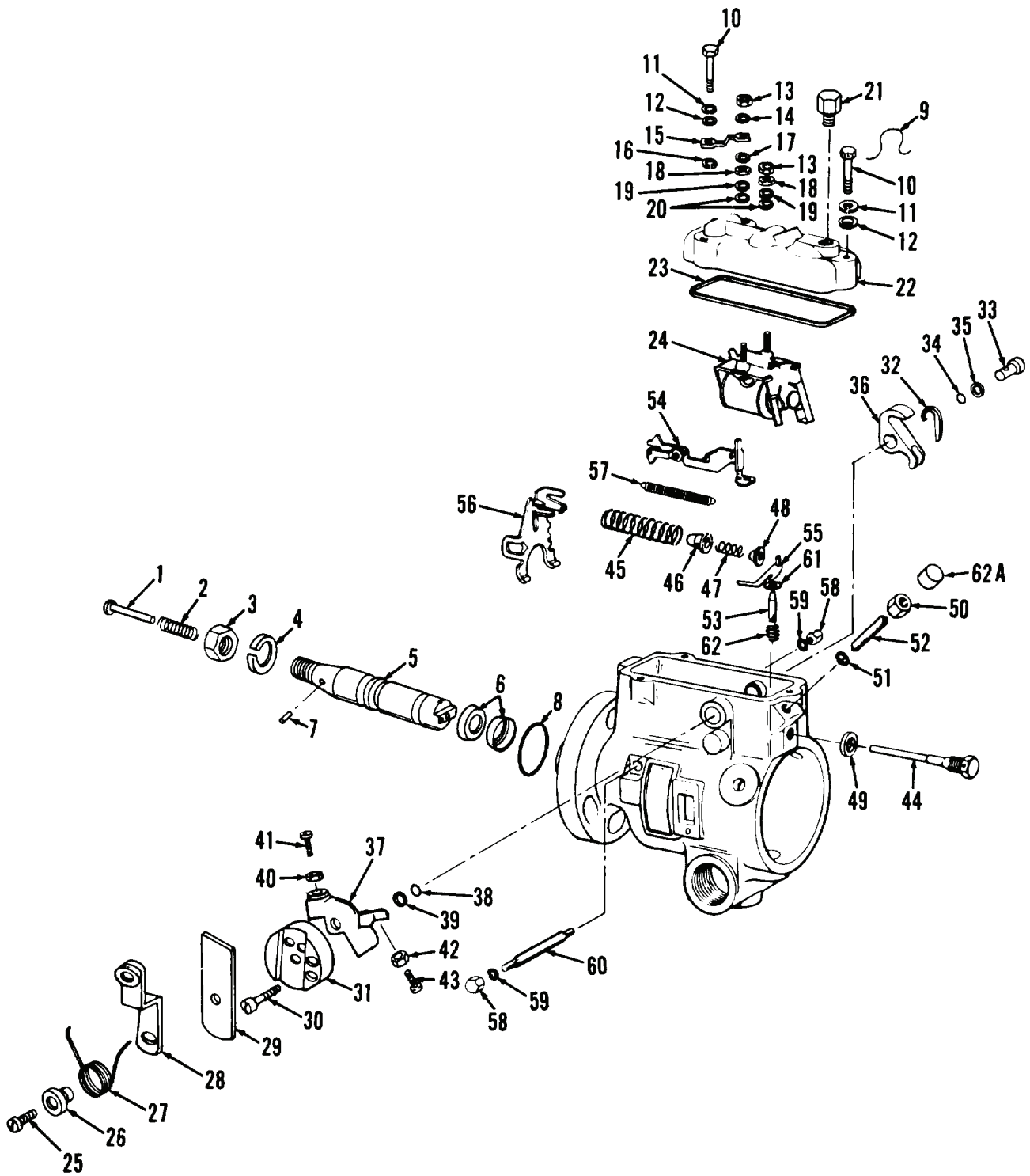

Figure 33. Fuel Injection Pump External Components.

TA127268

**ASSEMBLY - CONTINUED****NOTE**

In the following steps where grease is used to keep parts together to ease assembly, use grease sparingly as it can plug return fitting and pump will not bleed air from housing during start-up.

80. Assemble governor spring (Figure 36, Item 45), spring retainer (Figure 36, Item 46), idle spring (Figure 36, Item 47), and idling spring guide (Figure 36, Item 48) on bench. Apply a small amount of grease to these parts to keep them in place while assembling.
81. Loosen guide stud (Figure 36, Item 44) and withdraw it just enough to install assembly from step 80 as shown (Figure 34). Tighten guide stud to 110 to 115 lb-in. (12.4 to 13.0 Nm).

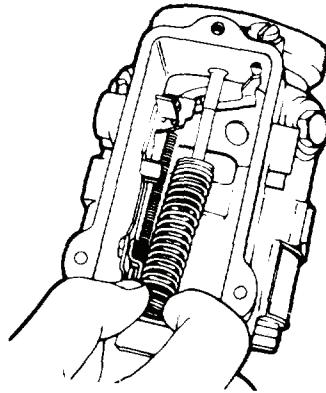

TA127294

**Figure 34. Installing Components on Guide Stud.**

82. Install washers (Figure 36, Items 35 and 39) and new seals (Figure 36, Items 34 and 38) on throttle shaft assembly (Figure 36, Item 37) and shutoff shaft (Figure 36, Item 33). Apply a light film of grease to each seal.
83. Install throttle shaft assembly (Figure 36, Item 37) partially through its bore in housing.
84. Install throttle shaft lever (Figure 36, Item 36). Slide over throttle shaft assembly (Figure 36, Item 37) so projection in lever (Figure 36, Item 36) bore engages keyway in shaft (Figure 36, Item 37). Position forked end of lever (Figure 36, Item 36) so it straddles guide stud (Figure 36, Item 44).
85. Install shutoff shaft (Figure 36, Item 33) with slight rotary motion so as not to damage seal (Figure 36, Item 34). If throttle shaft lever is installed properly, rotating throttle shaft assembly will cause spring (Figure 36, Item 45) to compress as shown (Figure 35).

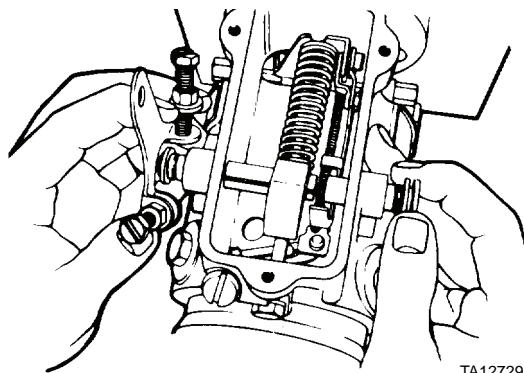

TA127295

**Figure 35. Installing Shutoff Shaft.**

ASSEMBLY - CONTINUED

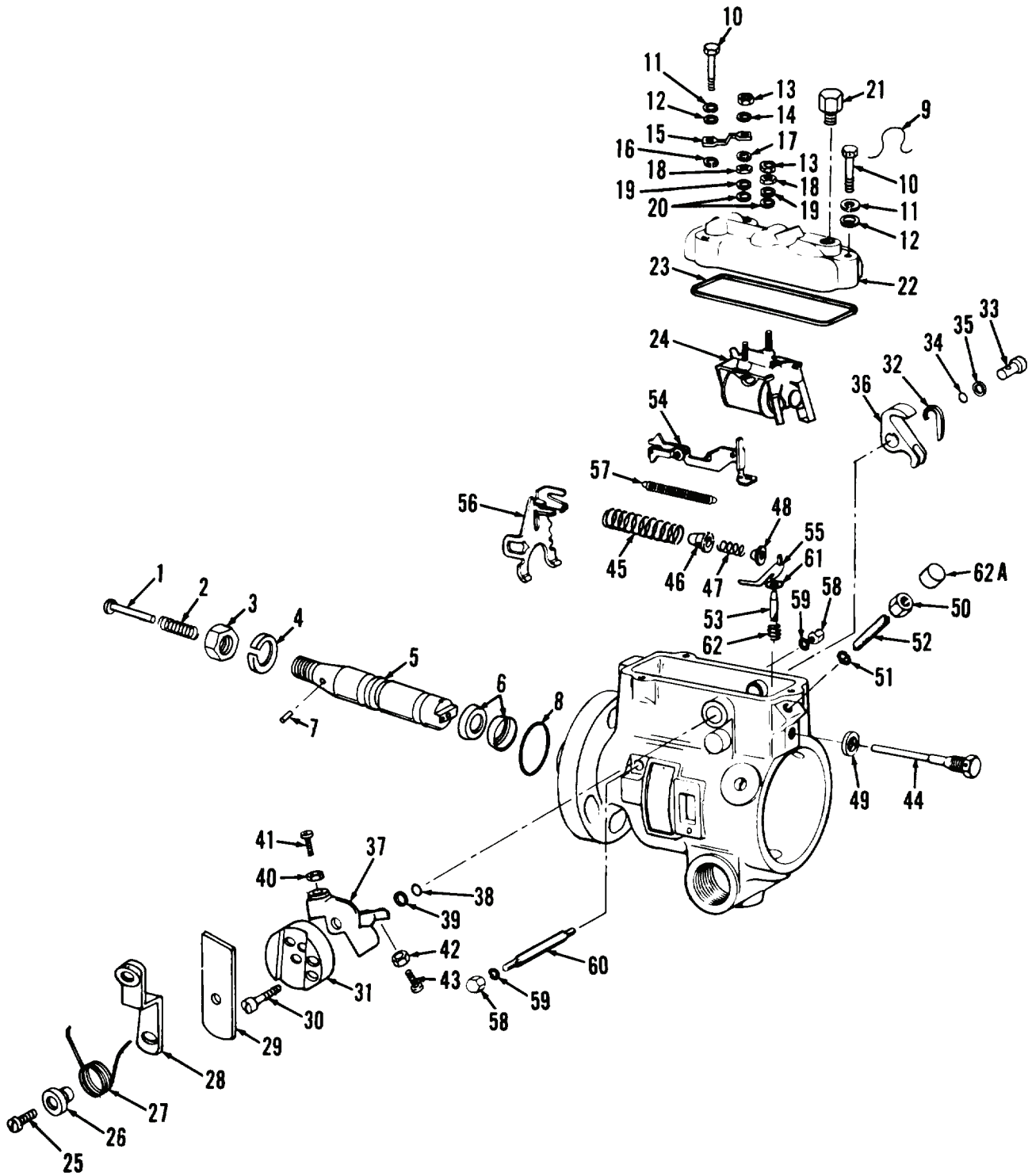

Figure 36. Fuel Injection Pump External Components.

TA127268

**ASSEMBLY - CONTINUED**

86. Install shaft retainer clip (Figure 38, Item 32).
87. Install torque screw (Figure 38, Item 52).
88. Install new seal (Figure 38, Item 51) in nut (Figure 38, Item 50).
89. Install nut (Figure 38, Item 50) and cap (Figure 38, Item 62A) on torque screw (Figure 38, Item 52).
90. Install nut (Figure 38, Item 40) on low-idle adjusting screw (Figure 38, Item 41).
91. Install low-idle adjusting screw (Figure 38, Item 41) in throttle shaft assembly (Figure 38, Item 37).
92. Install nut (Figure 38, Item 42) on high-idle adjusting screw (Figure 38, Item 43).
93. Install high-idle adjusting screw (Figure 38, Item 43) in throttle shaft assembly (Figure 38, Item 37).

**NOTE**

Perform steps 94 through 101 to adjust gap of linkage to 0.125 to 0.165 in. (3.18 to 4.19 mm).

94. Loosen nut (Figure 38, Item 50) and back out torque screw (Figure 38, Item 52).
95. Hold throttle shaft lever (Figure 38, Item 36) in wide open position.
96. Using linkage hook adjustment gauge tool P/N 18914, measure clearance between rear of shutoff shaft (point B) and vertical tab (point A) on linkage hook (Figure 38, Item 54) as shown (Figure 37).

**NOTE**

Adjustment is accomplished by changing the effective length of linkage hook using linkage hook wrench tool P/N 13379.

97. With linkage adjusting screw (point D) tight, apply a slight pressure to vertical tab (point A). At the same time, rotate pump one or two revolutions to ensure linkage is in full forward position.
98. Loosen linkage adjusting screw (point D) and slide linkage to maximum open length.
99. Insert linkage hook adjustment gauge tool P/N 18914 between vertical tab (point A) and shutoff shaft (point B) and slide linkage hook together from rear until face of tab is flush against gauge.
100. Tighten linkage adjusting screw (point D).

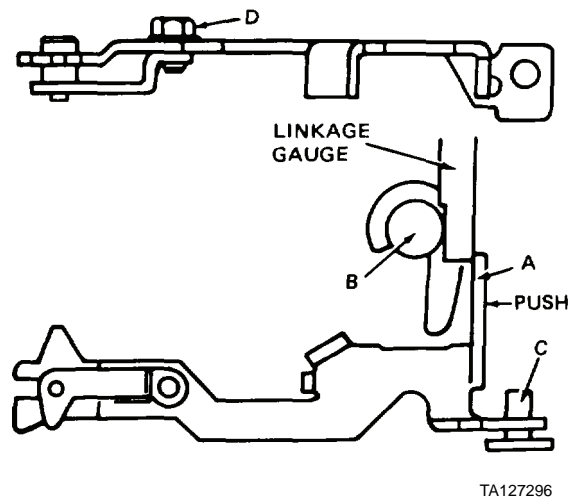

**Figure 37. Adjusting Linkage.**

ASSEMBLY - CONTINUED

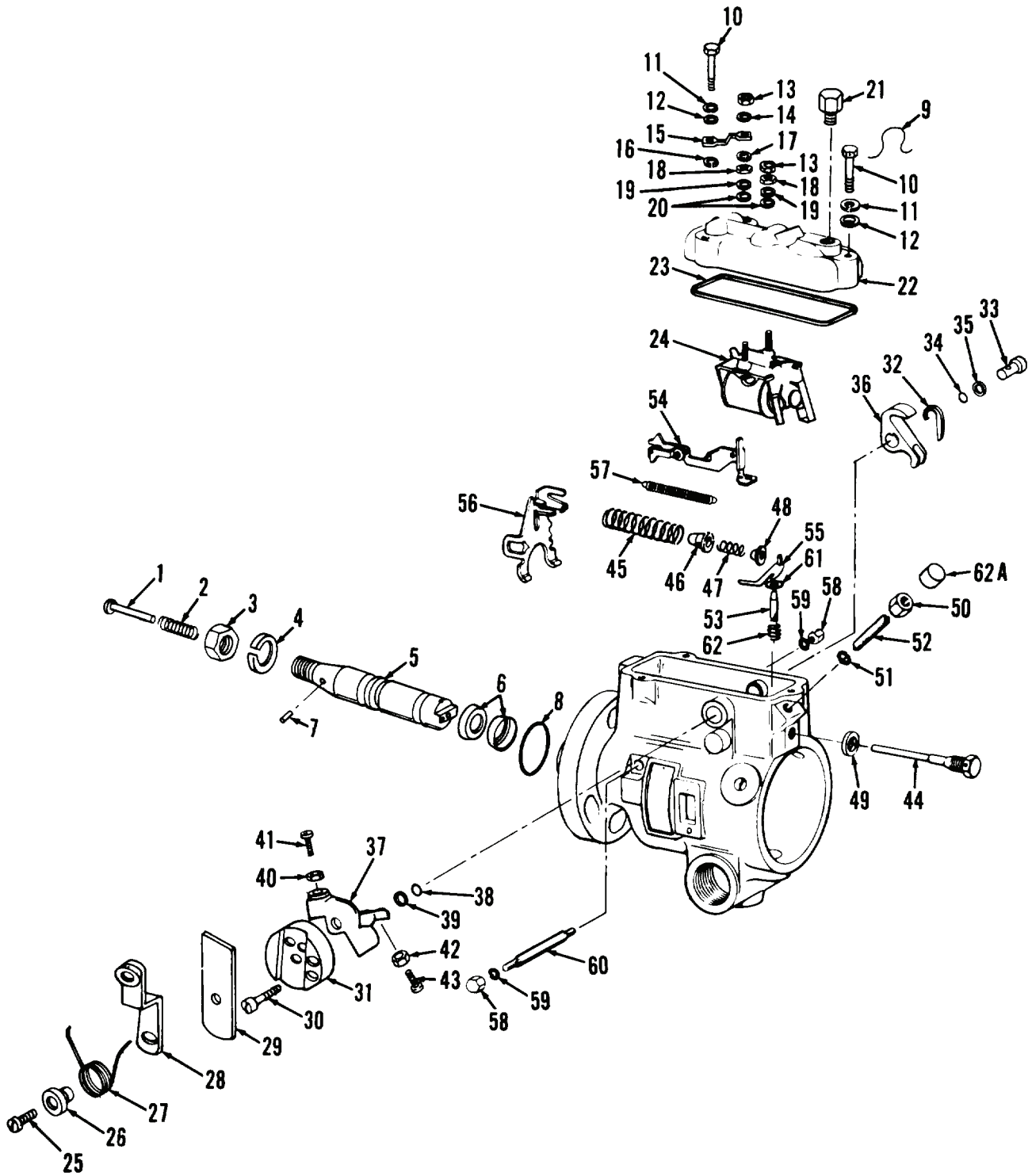
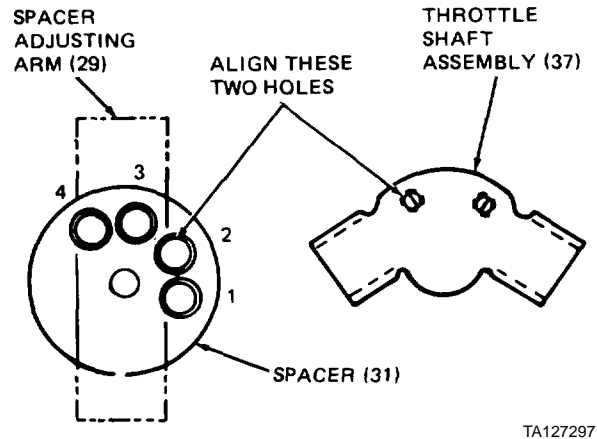

Figure 38. Fuel Injection Pump External Components.

TA127268

**ASSEMBLY - CONTINUED**

101. Check adjustment. Gap should be 0.125 to 0.165 in. (3.18 to 4.19 mm). Reset if necessary.
102. At side of housing, position spacer (Figure 40, Item 31). Line up holes as shown (Figure 39) and install screw (Figure 40, Item 30).



**Figure 39. Spacer Alignment.**

103. Install spring retainer (Figure 40, Item 26) and throttle lever spring (Figure 40, Item 27) on screw (Figure 40, Item 25).
104. Position spacer adjusting arm (Figure 40, Item 29) in recess of spacer (Figure 40, Item 31).
105. Position throttle lever assembly (Figure 40, Item 28) on spacer adjusting arm (Figure 40, Item 29).
106. Install screw (Figure 40, Item 25), spring retainer (Figure 40, Item 26), and throttle lever spring (Figure 40, Item 27) as an assembly. Finger tighten.
107. Position ends of throttle lever spring (Figure 40, Item 27). Cross ends over each other to clamp throttle lever (Figure 40, Item 28) and arm (Figure 40, Item 29) together.
108. Tighten screw (Figure 40, Item 25) to 35 to 40 lb-in. (3.9 to 4.5 Nm).
109. Position governor control cover (Figure 40, Item 22) on solenoid frame and arm assembly (Figure 40, Item 24).
110. Install two insulating washers (Figure 40, Item 20), washers (Figure 40, Item 19), and nuts (Figure 40, Item 18). Tighten nuts to 20 to 25 lb-in. (2.3 to 2.8 Nm).
111. Position new gasket (Figure 40, Item 23) on top of housing.

ASSEMBLY - CONTINUED

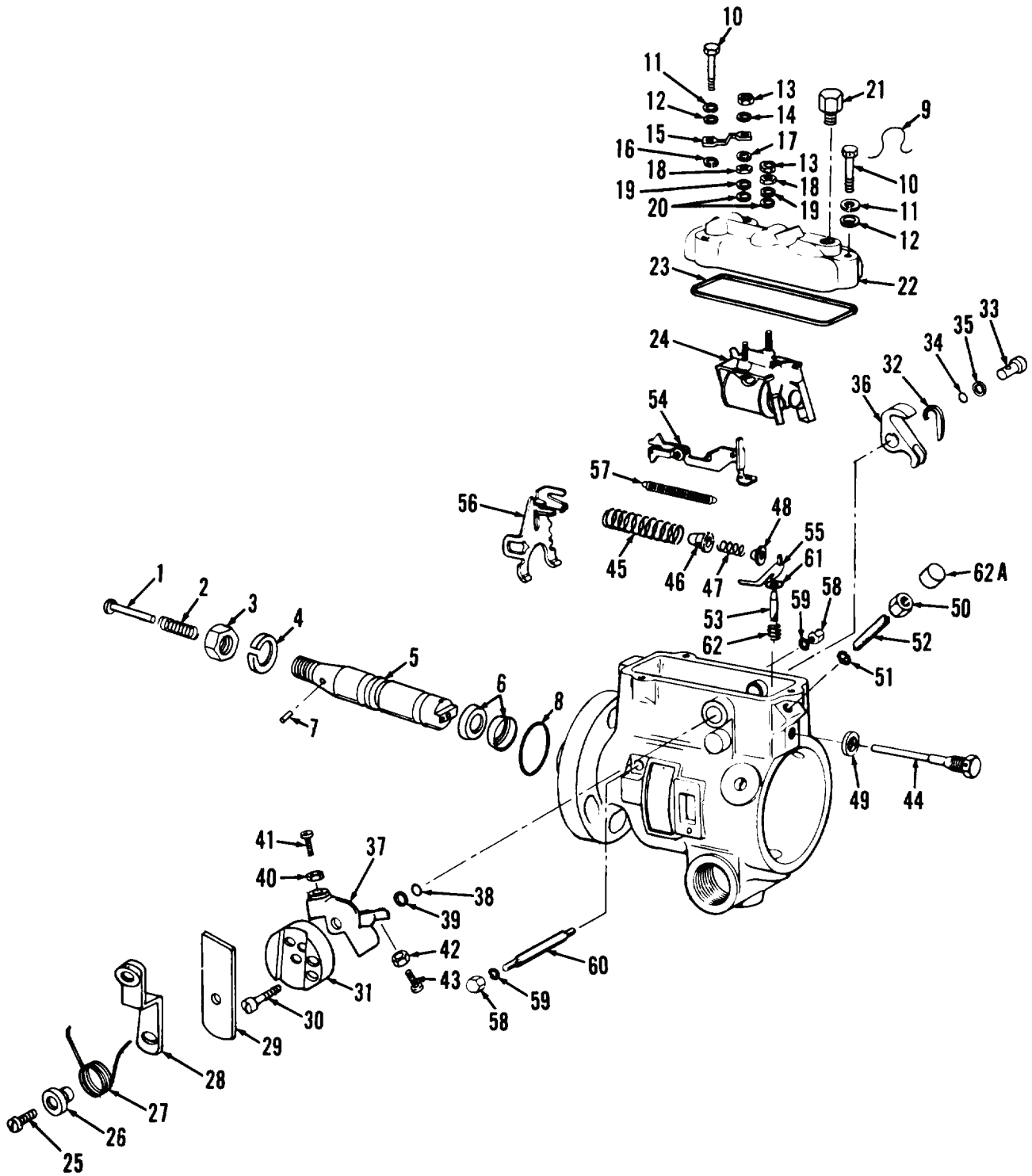

Figure 40. Fuel Injection Pump External Components.

TA127268

**ASSEMBLY - CONTINUED****CAUTION**

Exercise extreme caution in step 112 when installing governor control cover. It is possible to locate solenoid shutoff arm on the wrong side of linkage hook tab, thus locking linkage hook in full run position, blocking all governor action. If this condition exists, engine may accelerate to dangerously high speeds when started.

112. Install governor control cover (Figure 41, Item 22). Back out low-idle adjusting screw (Figure 41, Item 41) and push throttle lever (Figure 42, Item 36) into shutoff position. Move governor control cover down toward pump in a position further toward drive shaft end than normal. Just before governor control cover touches housing, slide cover into alignment with housing.
113. Position two lockwashers (Figure 41, Items 16 and 17) and grounding strap (Figure 41, Item 15) on top of governor control cover (Figure 41, Item 22).
114. Install three new lockwashers (Figure 41, Item 12), new lockwashers (Figure 41, Item 11), and screws (Figure 41, Item 10). Tighten screws to 35 to 45 lb-in. (3.9 to 5.1 Nm).
115. Install washer (Figure 41, Item 14) and two nuts (Figure 41, Item 13).
116. Install connector (Figure 41, Item 21). Tighten connector to 200 lb-in. (22.6 Nm).
117. Using wire, secure throttle shaft assembly (Figure 41, Item 37) in wide open position.
118. Remove drive shaft (Figure 41, Item 5) from housing.
119. Install new pilot tube seal (Figure 41, Item 8) on housing.
120. Install new roll pin (Figure 41, Item 7) on drive shaft (Figure 41, Item 5), if removed.

**NOTE**

Place two new seals (Figure 41, Item 6), drive shaft (Figure 41, Item 5), lockwasher (Figure 41, Item 4), nut (Figure 41, Item 3), spring (Figure 42, Item 2), and thrust plunger (Figure 41, Item 1) in a small cloth bag. These parts will be assembled when fuel injection pump is installed. Attach bag to fuel injection pump securely.

121. At sides of housing, install two new gaskets (Figure 41, Item 126) and timing line covers (Figure 41, Item 125) with four screws (Figure 41, Item 124). Tighten screws to 15 to 20 lb-in. (1.7 to 2.3 Nm).
122. Install eight washers (Figure 41, Item 113) and four fuel line connector screws (Figure 41, Item 112) on hydraulic head (Figure 41, Item 81) of fuel injection pump. Finger tighten screws.
123. Install two head-locking screws (Figure 41, Item 63) on fuel injection pump. Tighten screws to 360 lb-in. (40.7 Nm).



ASSEMBLY - CONTINUED

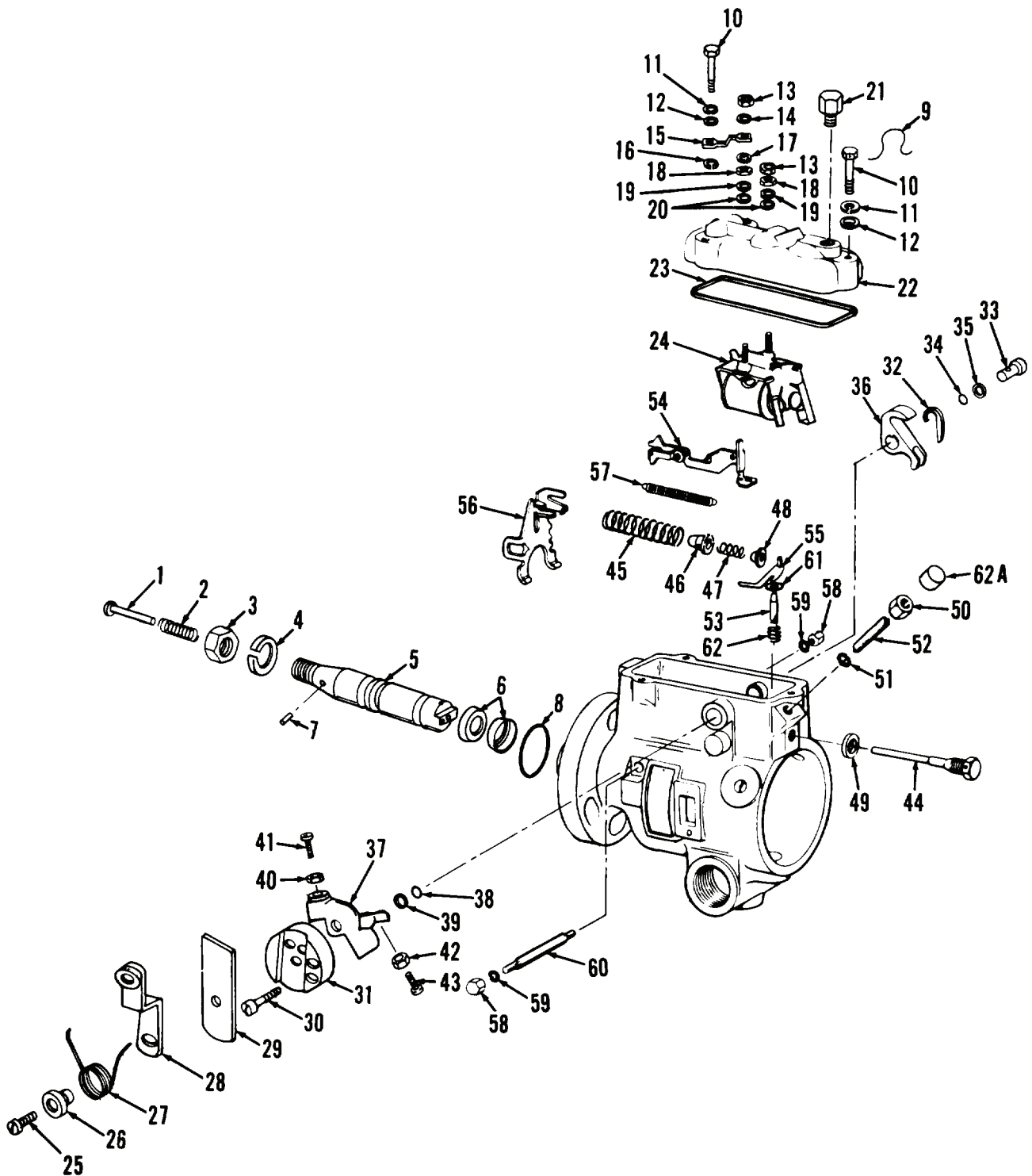

TA127268

Figure 41. Fuel Injection Pump External Components.

END OF TASK

---

**TESTING****NOTE**

Test bench must use calibrating nozzles type DN12SD12 (opening pressure 2,500 PSI [17,237 kPa]) and injection lines must be 3/32 in. ID by 20 in. (508 mm) long; holder BKB50SD and 0.5 mm plate and lines 1/16 in. ID by 25 in. (635 mm) long; Mobile Velocite No. 3 calibrating oil and calibrating oil temperature at 110 to 115°F (43 to 46°C). Test stand coupling should be of the self-aligning zero backlash type. Mount and drive the pump according to the test bench manufacturer's instructions.

1. At end plate (Figure 42, Item 88) of fuel injection pump, remove plug (Figure 42, Item 91) from sleeve (Figure 42, Item 92).
2. Install a pump inlet connector on sleeve (Figure 42, Item 92). Use two wrenches so pump outlet fitting does not move at the same time. Install transfer pressure gauge adapter P/N 21900, then a shutoff valve to isolate gauge when not in use. Connect pressure gauge to adapter P/N 21900.
3. At sides of housing, remove four screws (Figure 42, Item 124) and two timing line covers. Install advance window tool P/N 19918 in place of timing line covers.

TESTING - CONTINUED

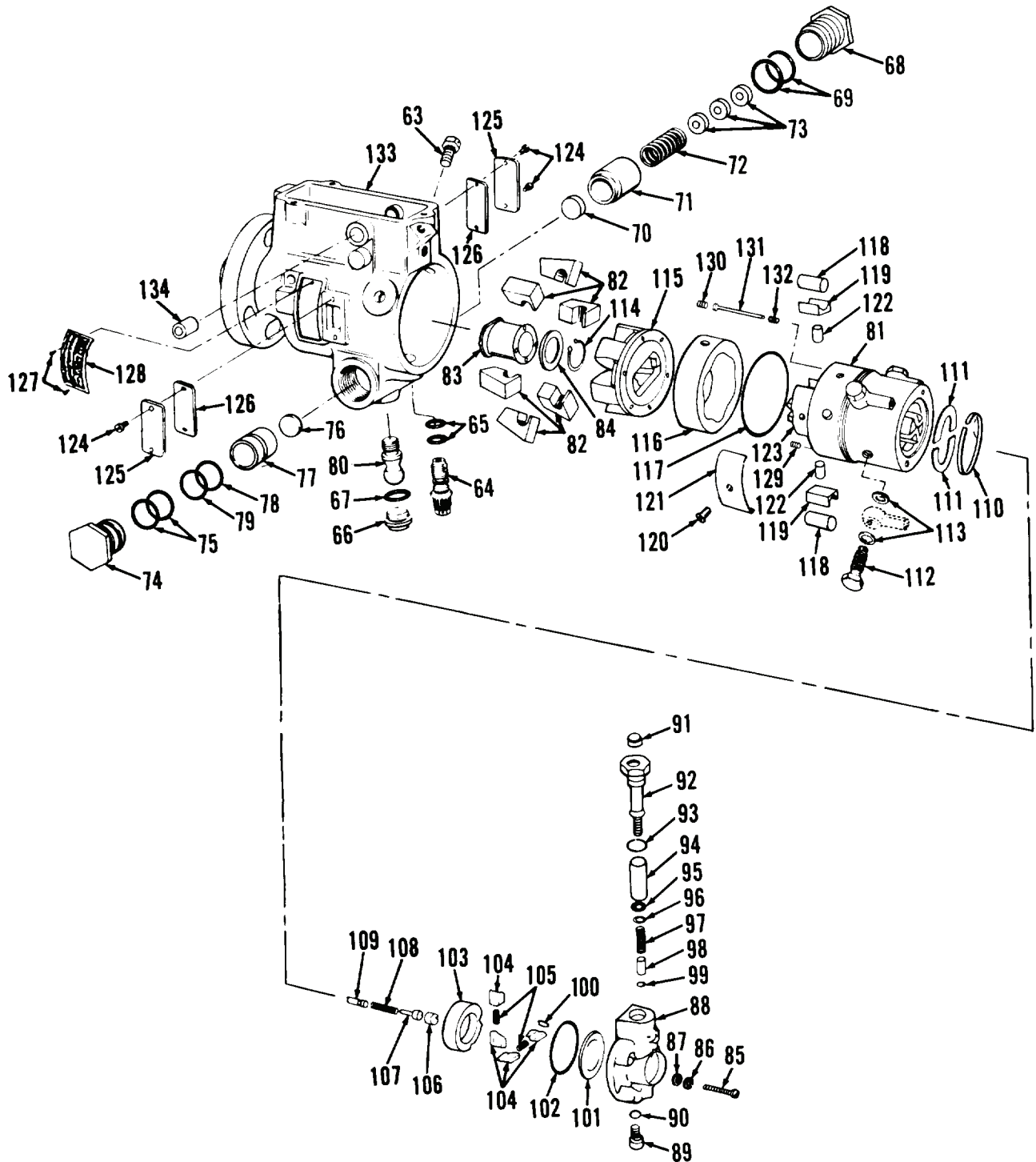

Figure 42. Fuel Injection Pump Internal Components.

TA127274

**TESTING - CONTINUED****NOTE**

Pump rotation is counterclockwise as viewed from drive shaft end of pump.

4. Connect a +24 VDC battery and switch to solenoid terminals at top of governor control cover (Figure 43, Item 22).
5. Place switch connected to battery in ON position.
6. Move pump throttle shaft assembly (Figure 43, Item 37) to full load position. When transfer pump is primed, bleed fuel for several seconds by loosening injection line nuts at fuel nozzles. Then, tighten nuts securely.

**WARNING**

Particles blown by compressed air are hazardous. DO NOT exceed 15 PSI (103 kPa) nozzle pressure when drying parts with compressed air. DO NOT exceed 30 PSI (207 kPa) nozzle pressure when cleaning parts with compressed air. DO NOT direct compressed air against human skin. Failure to follow this warning may result in injury to personnel. Make sure air stream is directed away from user and other personnel in the area. To prevent injury, user must wear protective goggles or face shield.

**NOTE**

1 to 3 PSI supply pressure is required at pump inlet.

7. At test stand, operate fuel injection pump at 1,000 RPM, wide open throttle, for 10 minutes. Dry pump off completely, if necessary, with compressed air. Check for leaks and correct if necessary.
8. At side of housing, back out low-idle adjusting screw (Figure 43, Item 41) and high-idle adjusting screw (Figure 43, Item 43).
9. At top of housing, back out torque screw (Figure 43, Item 52).
10. Perform a vacuum check by closing shutoff valve in fuel supply line and operating pump at 400 RPM. Transfer pump must create a vacuum of at least 18 in. of mercury. If not, check for air leaks between pump inlet and shutoff valve or deficiencies in transfer pump components.
11. Perform a return oil check by filling graduates to bleed air from test stand and to wet graduates. Operate fuel injection pump at  $2,100 \pm 10$  RPM. Direct return oil flow into calibrated graduate. Return oil flow must be  $200 \pm 500$  cc/minute.

TESTING - CONTINUED

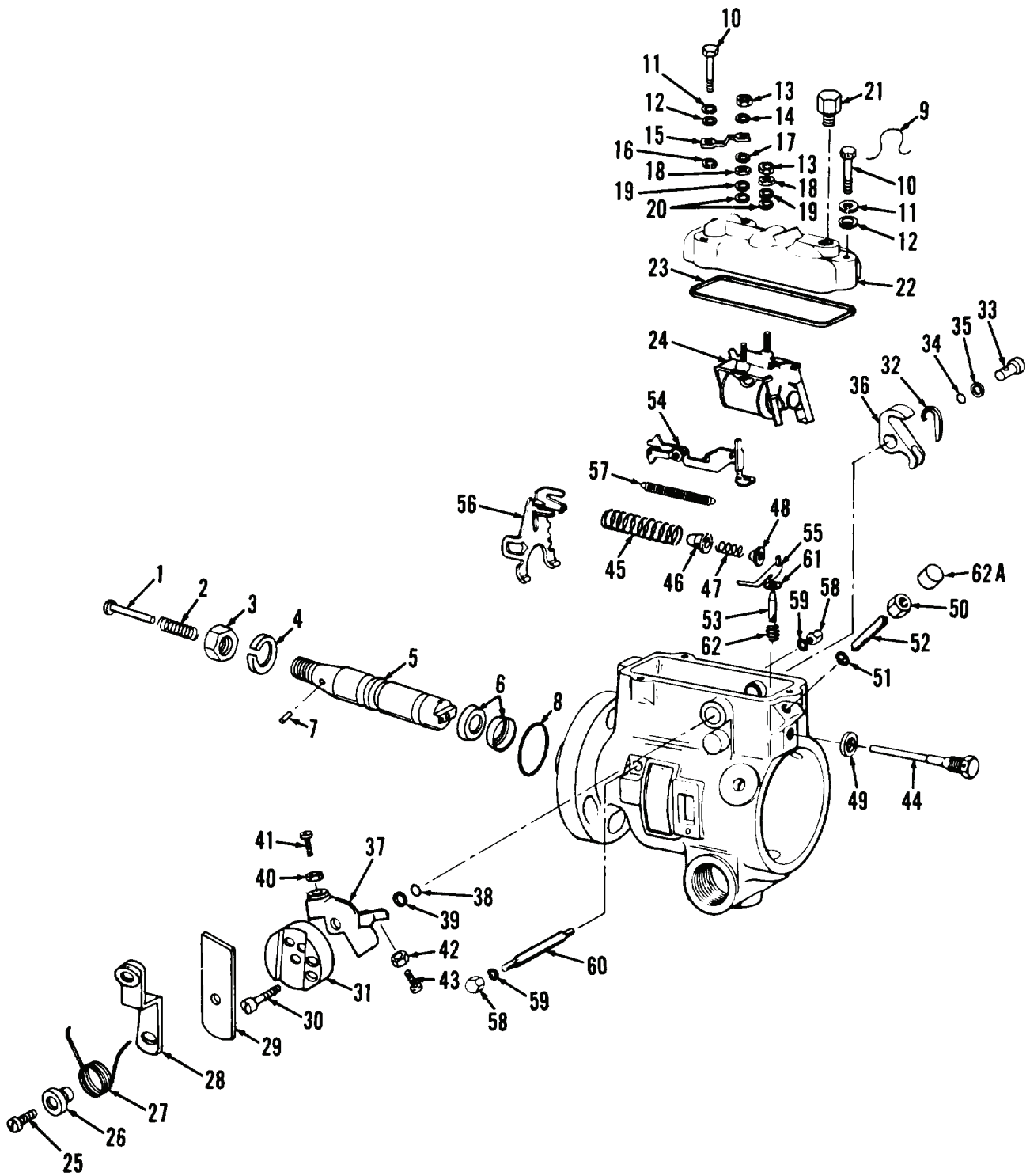

Figure 43. Fuel Injection Pump External Components.

TA127268

**TESTING - CONTINUED****CAUTION**

Under no circumstances exceed 130 PSI (896 kPa) when performing step 12.

12. Perform a transfer pump pressure check by operating fuel injection pump at  $2,100 \pm 10$  RPM. Transfer pump pressure must be 67 to 71 PSI (462 to 490 kPa).

**NOTE**

Transfer pump pressure gauge must be isolated by the shutoff valve at injection pump when checking fuel delivery and advance movement.

13. Perform fuel minimum delivery check by operating fuel injection pump at  $150 \pm 10$  RPM. Minimum delivery must be 25 cubic mm/stroke.
14. Perform a high speed delivery check by operating fuel injection pump at  $2,300 \pm 10$  RPM. High speed delivery must be 11 to 14 cubic mm/stroke. If necessary, adjust high-idle screw (Figure 43, Item 43) to obtain correct delivery. Repeat pressure check (step 12).
15. Perform low idle delivery check by operating fuel injection pump at  $750 \pm 10$  RPM. Low idle delivery must be 10 to 13 cubic mm/stroke. If necessary, adjust low-idle screw (Figure 43, Item 41) to obtain correct delivery.
16. Perform automatic advance check by observing advance window. Each line on advance window equals two pump degrees; cam has a line etched on it which is observed at window. Perform these steps:
  - a. Operate pump at 650 to 950 RPM. Cam movement must be 1 degree.
  - b. Operate pump at 1,250 to 1,450 RPM. Cam movement must be 5 degrees.
  - c. Operate pump at 1,700 to 1,900 RPM. Full advance (8 -0, +1 degrees).
  - d. Set test stand for 0 RPM at fuel injection pump. Ensure cam returns to its initial position. Recheck transfer pump pressure (step 12).
17. Check fuel delivery by performing these steps:
  - a. Operate pump at  $1,400 \pm 10$  RPM. Fuel delivery must be  $61 \pm 1.5$  cubic mm/stroke.
  - b. Operate pump at  $150 \pm 10$  RPM. Fuel delivery must be 25 cubic mm/stroke minimum.
  - c. Operate pump at  $2,300 \pm 10$  RPM. Fuel delivery must be 11 to 14 cubic mm/stroke.
  - d. Operate pump at  $750 \pm 10$  RPM. Fuel delivery must be 10 to 13 cubic mm/stroke.
18. Perform torque screw adjustment by performing these steps:
  - a. Operate pump at  $2,100 \pm 10$  RPM. Adjust torque screw (Figure 43, Item 52) until fuel delivery of 58 to 60 cubic mm/stroke is obtained.
  - b. Operate pump at  $150 \pm 10$  RPM. Fuel delivery must be 25 cubic mm/stroke.
19. Perform governor cutoff check by operating fuel injection pump at  $2,350 \pm 10$  RPM. Fuel delivery must be 5 cubic mm/stroke maximum.
20. Perform shutoff check by operating fuel injection pump at  $2,100 \pm 10$  RPM. Disconnect +24 VDC from solenoid; fuel delivery must be 3 cubic mm/stroke maximum.
21. Tighten nuts (Figure 43, Items 40, 42, and 50) to 25 to 30 lb-in. (2.8 to 3.4 Nm).
22. Remove two advance windows from housing. Install two timing line covers with four screws. Tighten screws to 15 to 20 lb-in. (1.7 to 2.3 Nm).
23. Secure throttle in wide open throttle position with length of safety wire (Figure 43, Item 9).
24. Remove fuel injection pump from test stand.
25. At four screws of end plate, thread length of safety wire (Figure 43, Item 9) through head of each screw and secure.
26. At governor control cover (Figure 43, Item 22), thread length of safety wire (Figure 43, Item 9) through head of screw (Figure 44, Item 10) and torque screw (Figure 43, Item 52) and secure.
27. At lever of throttle shaft assembly (Figure 43, Item 37), thread length of safety wire individually through heads of screws (Figure 43, Items 41 and 43) and secure.

TESTING - CONTINUED

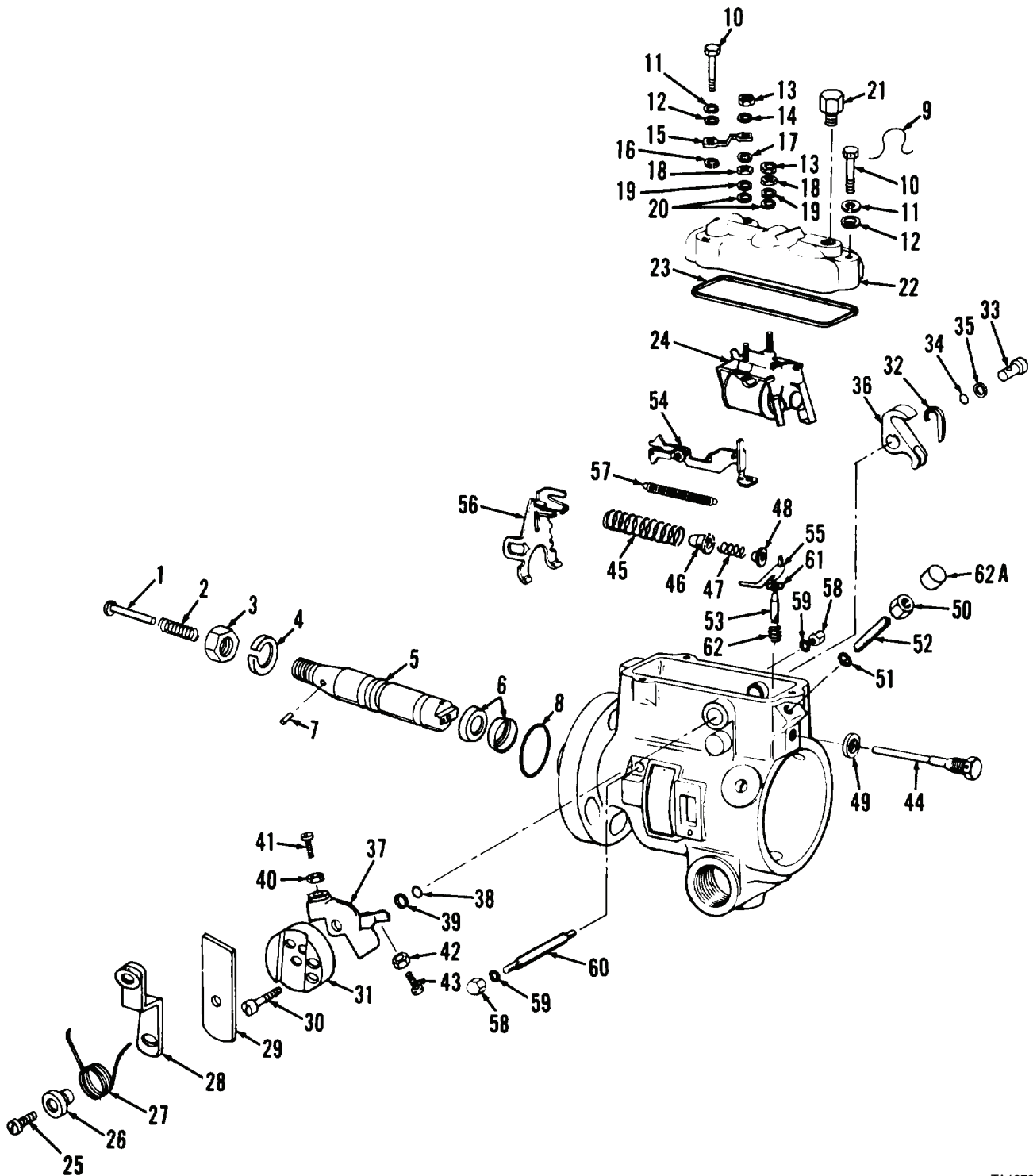

Figure 44. Fuel Injection Pump External Components.

TA127268

END OF TASK

END OF WORK PACKAGE





---

# GENERAL SUPPORT MAINTENANCE INSTRUCTIONS

## TORQUE CONVERTER REPAIR

### Disassembly, Cleaning, Inspection, Assembly

---

#### INITIAL SETUP

##### Maintenance Level

General Support

##### Tools and Special Tools

Tool kit, general mechanic's (Item 15, WP 0309)  
Shop equipment, common no. 1 (Item 2, WP 0309)  
Container  
Chain hoist, 1/2-ton capacity  
Heat-resistant gloves  
Mechanical puller (NSN 5120-00-423-1596)  
Oven  
Sleeve, 2-1/4-in. diameter  
Soft hone  
Tongs

##### Materials/Parts

Cleaning compound, solvent (Item 10, WP 0310)  
Grease, automotive and artillery (Item 17, WP 0310)  
Lubricating oil, OE/HDO-10 (Item 20, WP 0310)  
Rag, wiping (Item 26, WP 0310)

##### Materials/Parts - Continued

Sealing compound, brown (Item 29, WP 0310)  
Loctite 529  
Gasket  
Locating ring (6)  
Lockwasher (48)  
O-ring (2)  
Retaining ring  
Sealing ring

##### Personnel Required

Two

##### References

WP 0295

##### Equipment Condition

Oil drained from transmission (WP 0143)  
Transmission separated from engine (WP 0213 or WP 0214)  
Charging pump assembly removed (WP 0251)  
Control valve and modulation valve assemblies removed (WP 0250)

---

**DISASSEMBLY**

1. At front of transmission, remove 10 screws and lockwashers (Figure 4, Item 1). Discard lockwashers.
2. Remove backing ring (Figure 4, Item 2), two drive plates (Figure 4, Item 3), and drive plate assembly (Figure 4, Item 4).
3. Remove retaining ring (Figure 4, Item 5).
4. Remove bore plug (Figure 4, Item 6) and O-ring (Figure 4, Item 7). Use two small screwdrivers, as shown, to remove bore plug.

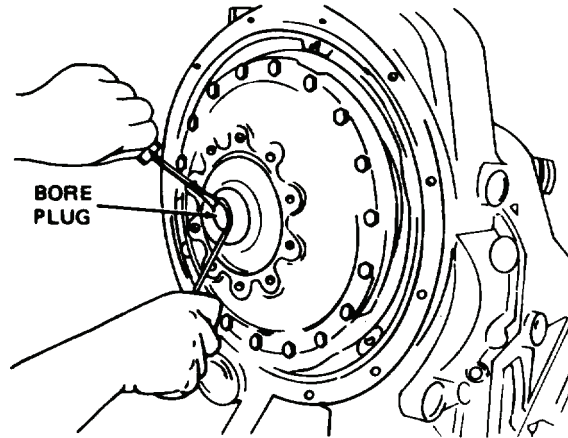

TA127300

**Figure 1. Removing Bore Plug.**

5. Remove turbine retaining ring (Figure 2, Item 8) through bore plug hole as shown.

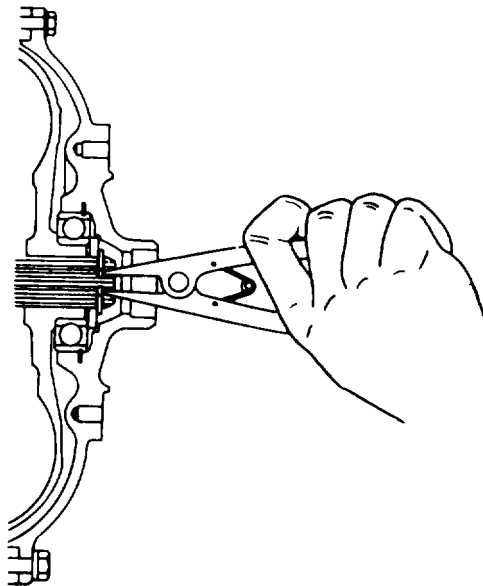

TA127301

**Figure 2. Removing Retaining Ring.**

**DISASSEMBLY - CONTINUED**

6. Remove 18 screws and lockwashers (Figure 3, Item 9) from impeller cover (Figure 3, Item 10). Discard lockwashers.

**NOTE**

- In step 7, turbine may remain in impeller cover bearing and come off with impeller cover.
- Before performing step 7, place container under converter housing to catch oil.

7. Remove impeller cover (Figure 3, Item 10) from impeller (Figure 3, Item 20).
8. Remove O-ring (Figure 3, Item 11) from impeller cover (Figure 3, Item 10). Discard O-ring.
9. If turbine (Figure 3, Item 15) remains in impeller cover (Figure 3, Item 10) bearing, remove turbine using a puller if necessary.
10. Remove retaining ring (Figure 3, Item 12).
11. Remove bearing (Figure 3, Item 13). Press out using suitable size sleeve.
12. Remove retaining washer (Figure 3, Item 14).
13. At front of transmission, remove turbine (Figure 3, Item 15).
14. Remove locating ring (Figure 3, Item 16) and retaining ring (Figure 3, Item 17). Discard rings.
15. Remove reaction member (Figure 3, Item 18) and bearing spacer (Figure 3, Item 19).
16. Remove impeller (Figure 3, Item 20) and hub gear (Figure 3, Item 23) as an assembly.
17. At impeller (Figure 3, Item 20), remove eight screws (Figure 3, Item 21), lock tab (Figure 3, Item 22), and impeller hub gear (Figure 3, Item 23) from impeller.
18. Remove O-ring (Figure 3, Item 24) from impeller (Figure 3, Item 20). Discard O-ring.
19. At front of transmission, remove oil baffle (Figure 3, Item 25). Use oil baffle puller holes, as shown, to remove.

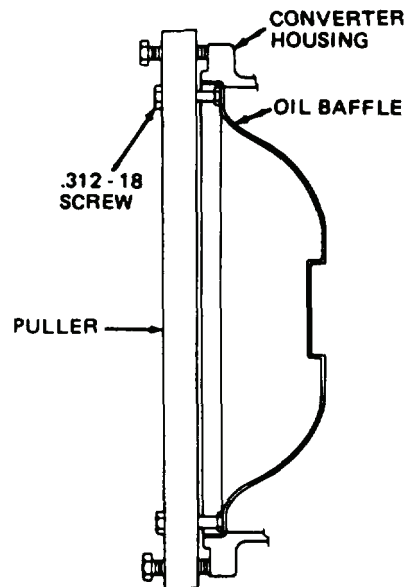

TA127304

**Figure 3. Removing Oil Baffle.**

**DISASSEMBLY - CONTINUED**

20. Remove oil seal (Figure 4, Item 26) from oil baffle (Figure 4, Item 25).
21. At idler gear (Figure 4, Item 28), remove locating ring (Figure 4, Item 27). Discard locating ring.
22. Remove idler gear (Figure 4, Item 28) and bearing (Figure 4, Item 31) as an assembly.
23. Remove two retaining rings (Figure 4, Items 29 and 30).
24. Remove bearing (Figure 4, Item 31) from idler gear (Figure 4, Item 28). Press out using suitable size sleeve.
25. Remove locating ring (Figure 4, Item 32). Discard locating ring.
26. At pump drive gear (Figure 4, Item 35), remove two screws (Figure 4, Item 33) and lockwashers (Figure 4, Item 55). Discard lockwashers.
27. Remove pump drive gear (Figure 4, Item 35) and bearing support (Figure 4, Item 39) from converter housing (Figure 4, Item 51) as an assembly. Use a soft hammer and tap pump drive gear and bearing support from housing.
28. Remove and discard locating ring (Figure 4, Item 34).
29. Remove retaining ring (Figure 4, Item 36) and bearing (Figure 4, Item 37).
30. Remove and discard locating ring (Figure 4, Item 38).
31. Remove bearing support (Figure 4, Item 39).
32. At auxiliary pump drive gear (Figure 4, Item 42), remove two screws (Figure 4, Item 40) and lockwashers (Figure 4, Item 41). Discard lockwashers.
33. Remove auxiliary pump drive gear (Figure 4, Item 42) and bearing support (Figure 4, Item 46) from converter housing (Figure 4, Item 51). Use soft hammer and tap auxiliary pump drive gear and bearing support from housing.
34. Remove retaining ring (Figure 4, Item 43), bearing (Figure 4, Item 44), locating ring (Figure 4, Item 45), and bearing support (Figure 4, Item 46) from auxiliary pump drive gear (Figure 4, Item 42). Discard locating ring.

**NOTE**

Before performing step 35, position container under screen assembly to catch hydraulic fluid.

35. At front of transmission, remove screen assembly (Figure 4, Item 47) and gasket (Figure 4, Item 48). Discard gasket. Remove all traces of gasket material from converter housing (Figure 4, Item 51).
36. Remove 16 screws (Figure 4, Item 49) and lockwashers (Figure 4, Item 50) from converter housing (Figure 4, Item 51), leaving only one screw and lockwasher securing converter housing to transmission.

**NOTE**

In step 37, reverse and second clutch assembly will remain in converter housing.

37. Attach chain hoist to converter housing (Figure 4, Item 51) and take up slack.
38. Remove remaining screw (Figure 4, Item 49) and lockwasher (Figure 4, Item 50) and separate converter housing (Figure 4, Item 51) from transmission. Discard lockwasher.
39. Remove retaining ring (Figure 4, Item 52). Use spreading type snap ring pliers to spread retaining ring on reverse and second clutch assembly.
40. Attach chain hoist to converter housing (Figure 4, Item 51) and take up slack.

**NOTE**

Refer to WP 0295 for repair of reverse and second clutch assembly.

41. While holding retaining ring (Figure 4, Item 52) open, pry reverse and second clutch assembly (Figure 4, Item 53) from converter housing. Remove and discard gasket (Figure 4, Item 54).

DISASSEMBLY - CONTINUED

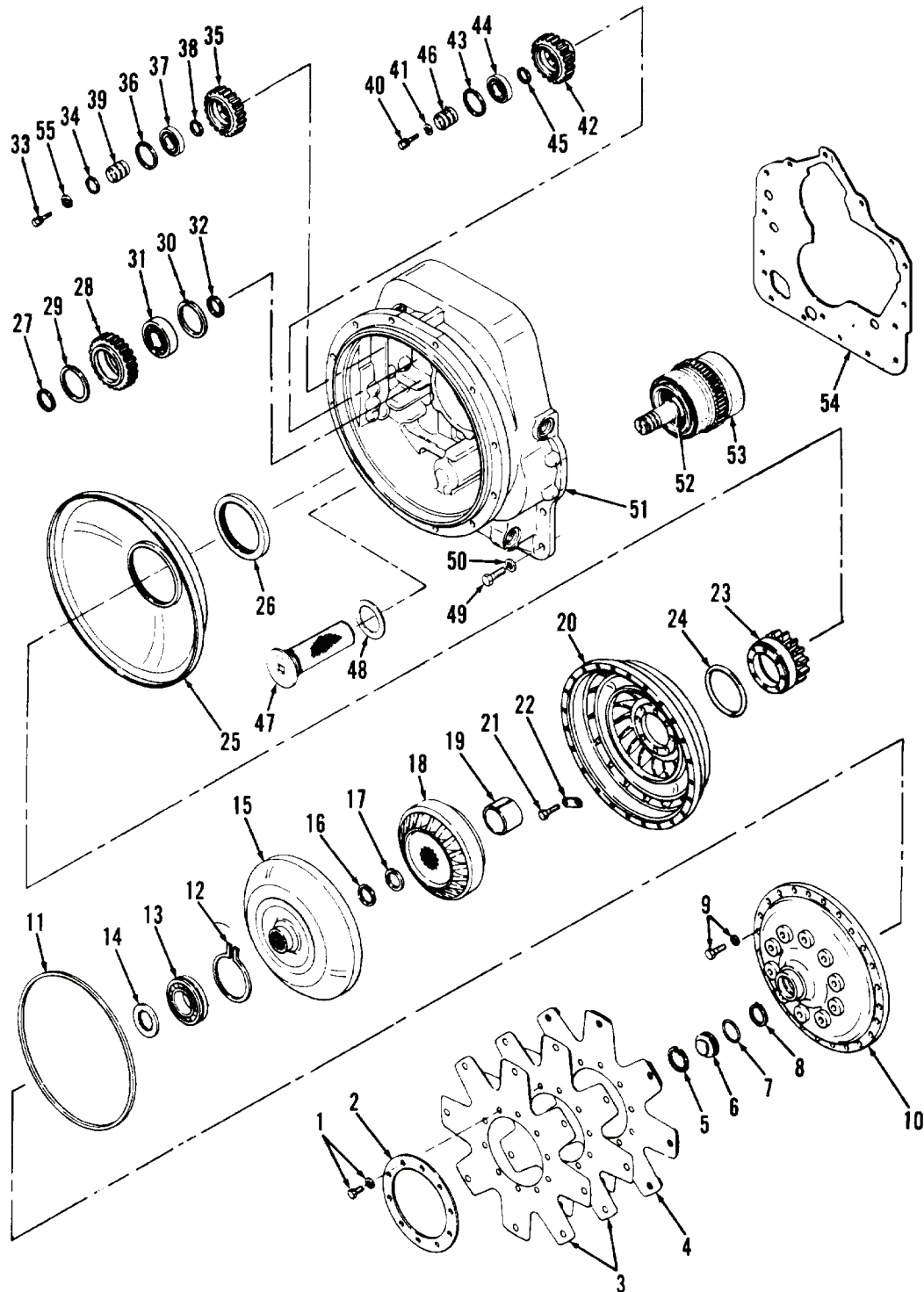

Figure 4. Torque Converter.

TA127299

END OF TASK

**CLEANING****WARNING**

- Solvent cleaning compound MIL-PRF-680 Type III is an environmentally compliant and low toxic material. However, it may be irritating to the eyes and skin. Use protective gloves and goggles. Use in well-ventilated areas. Keep away from open flames and other sources of ignition. Failure to do so may result in injury or death to personnel.
  - Particles blown by compressed air are hazardous. DO NOT exceed 15 PSI (103 kPa) nozzle pressure when drying parts with compressed air. DO NOT direct compressed air against human skin. Make sure air stream is directed away from user and other personnel in the area. To prevent injury, user must wear protective goggles or face shield. Failure to follow this warning may result in injury to personnel.
1. Clean all parts in solvent cleaning compound. Immerse parts in cleaning solvent and move up and down slowly until all old lubricant and foreign material is dissolved. Dry parts thoroughly after removal from cleaning solvent with moisture-free compressed air or clean rags.
  2. Clean bearings with solvent cleaning compound. Dry bearings with compressed air. Do not permit bearings to spin.
  3. Clean converter housing with clean rags moistened with solvent cleaning compound. Dry with compressed air.
  4. Clean reverse and second clutch assembly with clean rags moistened with solvent cleaning compound. Dry with compressed air.

**END OF TASK****INSPECTION**

1. Inspect bearings for wear, chipping, or nicks. Do not replace a bearing cone or cup individually without replacing mating cup or cone at same time. After inspection, dip bearings in clean, light lubricating oil and wrap in clean, lint-free rag or paper for protection until installed.
2. Inspect gear teeth and shafts for wear, pitting, chipping, nicks, cracks, or scores. Replace if defects are noted. If gear teeth show spots where case hardening is worn through or cracked, replace gear. Remove small nicks with suitable hone. Inspect shafts for bent, sprung, or twisted condition; replace if necessary.
3. Inspect all other parts. Replace if worn, cracked, bent, or distorted.

**END OF TASK****ASSEMBLY****NOTE**

Lubricate all seals and O-rings with lubricating oil prior to assembly.

1. Install reverse and second clutch assembly (Figure 5, Item 53) on disc hub. Be sure to align splines of disc hub with internal teeth of second clutch friction discs. Disc hub must be in full position with friction discs. Do not force this operation.
2. Position new gasket (Figure 5, Item 54) on front of transmission housing. Apply a thin coat of GAA grease to hold gasket in place.
3. Use spreading type snap ring pliers to spread retaining ring (Figure 5, Item 52). Lock pliers open to hold retaining ring open.

ASSEMBLY - CONTINUED

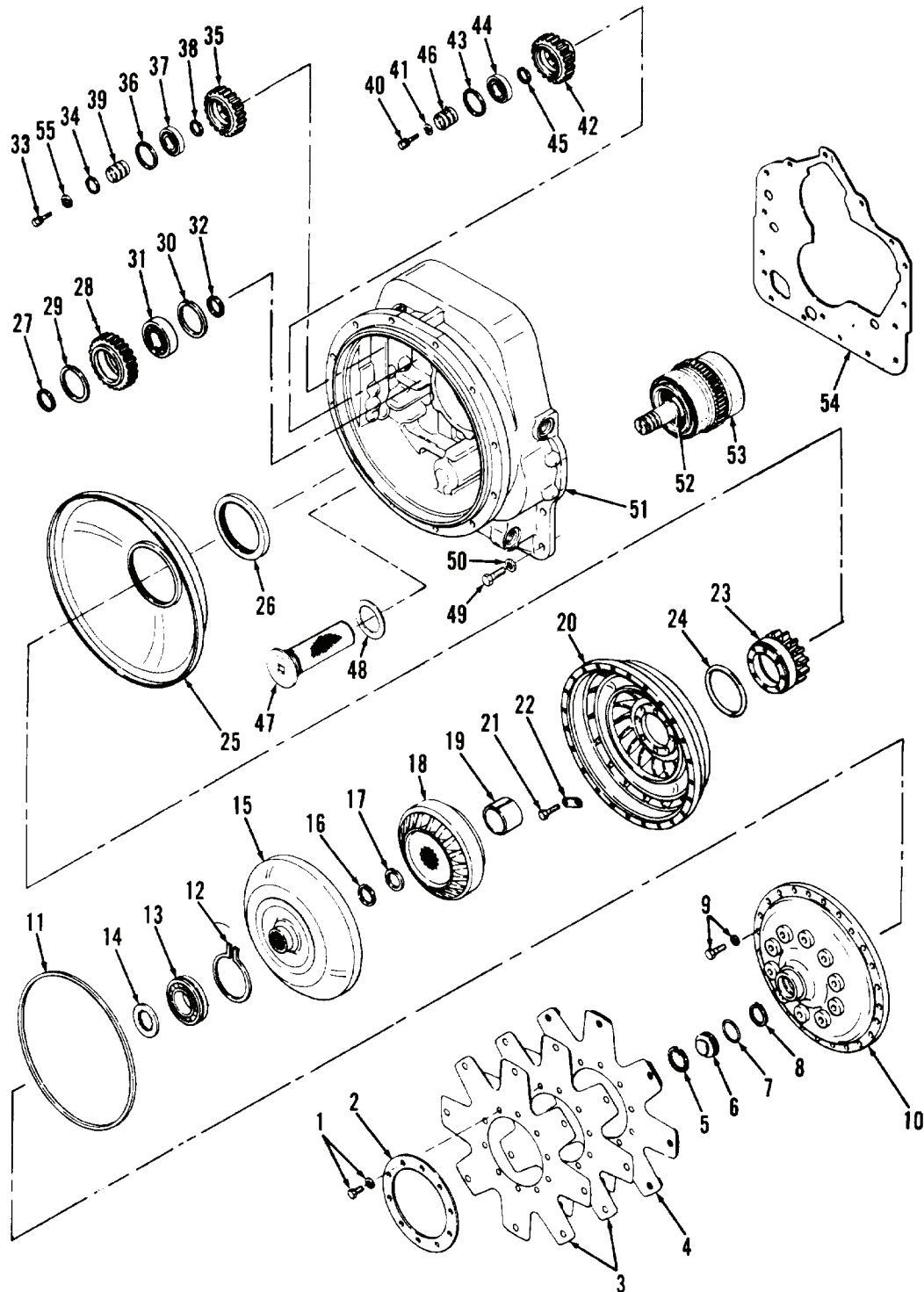

Figure 5. Torque Converter.

TA127299

**ASSEMBLY - CONTINUED****CAUTION**

When performing step 4, take care not to damage reverse clutch front piston ring.

4. Attach chain hoist to converter housing (Figure 7, Item 51) and take up slack.
5. Install a guide stud in any one mounting hole of transmission to aid in positioning converter housing (Figure 7, Item 51).
6. Using chain hoist, position converter housing (Figure 7, Item 51) on transmission and tap converter housing in place.
7. At front of converter housing (Figure 7, Item 51), install one screw (Figure 7, Item 49) and new lockwasher (Figure 7, Item 50) in front and one in rear. Use a slide type hammer puller, and pull reverse clutch gear toward front of converter housing to move reverse and second clutch assembly forward to align retaining ring groove in bearing with retaining ring (Figure 7, Item 52) in housing. Ensure retaining ring is in full position in ring groove before removing pliers.
8. Remove guide stud and install remaining screws (Figure 7, Item 49) and new lockwashers (Figure 7, Item 50). Tighten screws to 37 to 41 lb-ft (50 to 56 Nm).
9. Install new gasket (Figure 7, Item 48) and screen assembly (Figure 7, Item 47). Tighten screen assembly to 10 to 15 lb-ft (14 to 20 Nm).
10. At auxiliary pump drive gear (Figure 7, Item 42), install bearing (Figure 7, Item 44) and retaining ring (Figure 7, Item 43).
11. Install bearing support (Figure 7, Item 46) and new locating ring (Figure 7, Item 45).
12. Install bearing support (Figure 7, Item 46) and auxiliary pump drive gear (Figure 7, Item 42) assembly in converter housing (Figure 7, Item 51).
13. Install two screws (Figure 7, Item 40) and new lockwashers (Figure 7, Item 41). Tighten screws enough to hold bearing support in place. Then, tighten screws to 23 to 25 lb-ft (31 to 34 Nm).
14. At pump drive gear (Figure 7, Item 35), install bearing (Figure 7, Item 37) and retaining ring (Figure 7, Item 36).
15. Install bearing support (Figure 7, Item 39) and new locating ring (Figure 7, Item 38) until pump drive gear (Figure 7, Item 35) shoulders on locating ring.
16. Install new locating ring (Figure 7, Item 34).
17. Install bearing support (Figure 7, Item 39) and pump drive gear (Figure 7, Item 35) assembly in converter housing (Figure 7, Item 51).
18. Install three screws (Figure 7, Item 33) and new lockwashers (Figure 7, Item 55). Tighten screws enough to hold bearing support and gear in place. Then, tighten screws to 23 to 25 lb-ft (31 to 34 Nm).
19. Install new locating ring (Figure 7, Item 32) on stub shaft.
20. At idler gear (Figure 7, Item 28), install bearing (Figure 7, Item 31) and two retaining rings (Figure 7, Items 29 and 30).
21. Position idler gear (Figure 7, Item 28) and bearing (Figure 7, Item 31) on stub shaft.
22. Install new locating ring (Figure 7, Item 27).
23. Install new oil seal (Figure 7, Item 26) with lip of seal positioned as shown (Figure 6).

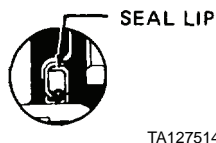

**Figure 6. Installing Seal.**



ASSEMBLY - CONTINUED

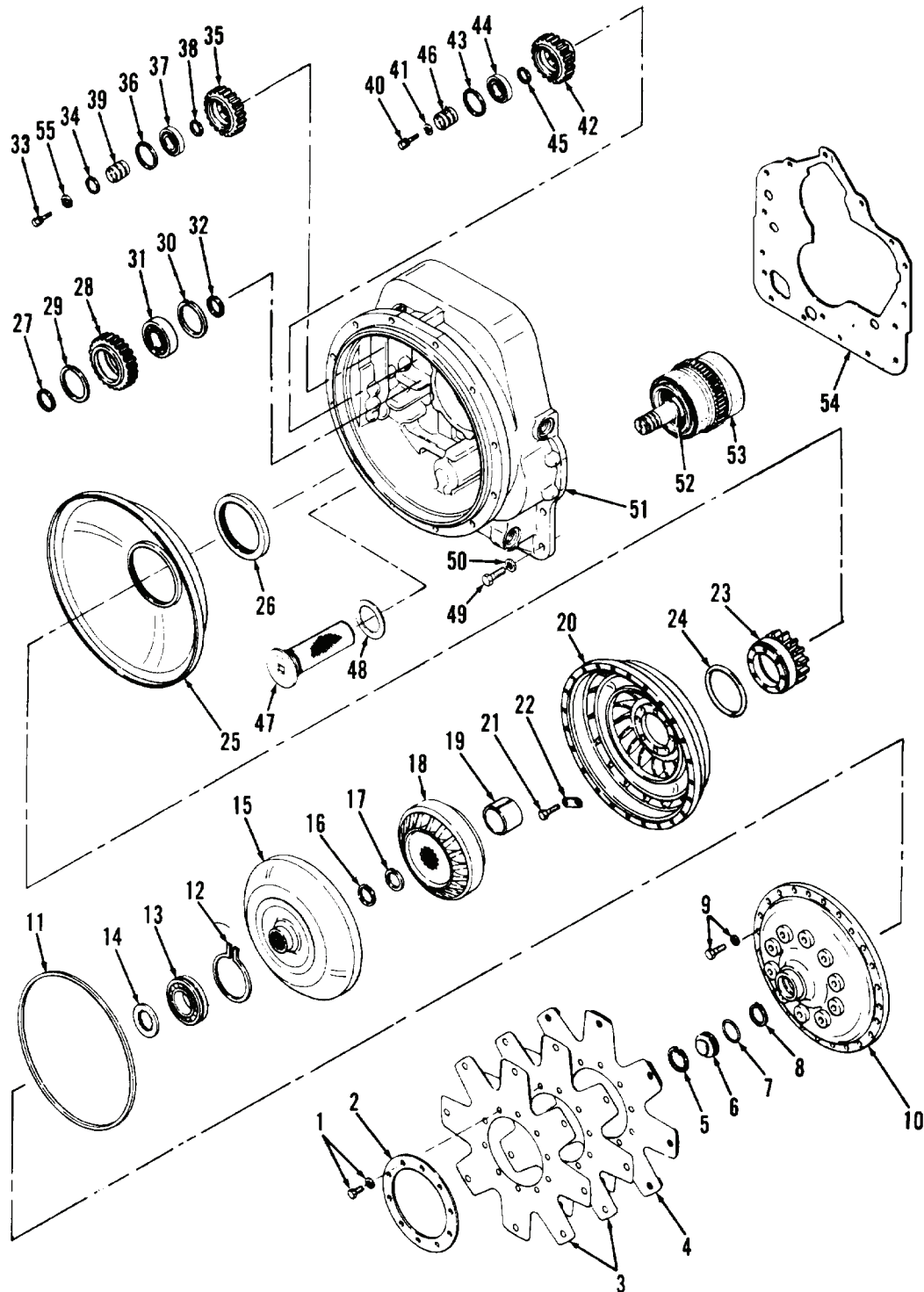

Figure 7. Torque Converter.

TA127299

**ASSEMBLY - CONTINUED**

24. Install oil baffle (Figure 8, Item 25). Apply a light coat of sealing compound (thread sealant) to outer diameter of oil baffle of counter bore in converter housing. Immediately remove any excess sealant that could enter oil circuit.
25. Position oil baffle puller screw holes 15 to 30 degrees on either side of vertical center line. Tap baffle (on outside diameter only) into position until baffle shoulders in converter housing.
26. Install new O-ring (Figure 8, Item 24) on impeller (Figure 8, Item 20).
27. Install impeller hub gear (Figure 8, Item 23) on impeller (Figure 8, Item 20).
28. Install eight lock tabs (Figure 8, Item 22) on impeller (Figure 8, Item 20) with eight screws (Figure 8, Item 21). Bend lock tabs over heads of screws.

**CAUTION**

In step 29, take care not to damage oil baffle oil seal.

29. Install impeller (Figure 8, Item 20) on converter housing (Figure 8, Item 51).
30. Install bearing spacer (Figure 8, Item 19), reaction member (Figure 8, Item 18), and retaining ring (Figure 8, Item 17).
31. Install new locating ring (Figure 8, Item 16) and turbine (Figure 8, Item 15).

**WARNING**

In steps 32 through 36, wear heat-resistant gloves or use tongs to handle impeller cover (10). Failure to do so could cause you to burn your hands.

32. Heat impeller cover (Figure 8, Item 10) in oven to 200 to 250°F (93 to 121°C).
33. Position retaining ring (Figure 8, Item 12) in groove in impeller cover (Figure 8, Item 10).
34. Install retaining washer (Figure 8, Item 14).
35. Install bearing (Figure 8, Item 13). While impeller cover (Figure 8, Item 10) is still hot, press bearing into position while spreading retaining ring (Figure 8, Item 12). Align ring groove in bearing with retaining ring. Then, release retaining ring. Check retaining ring to ensure it is fully secured in groove.
36. Install new O-ring (Figure 8, Item 11).

**CAUTION**

Be careful when you install assembled impeller cover not to damage O-ring.

37. Install impeller cover (Figure 8, Item 10) on impeller (Figure 8, Item 20). Be sure to align retaining washer (Figure 8, Item 14) with turbine shaft.
38. Install 18 screws and new lockwashers (Figure 8, Item 9). Tighten 11-in. impeller cover screws to 12 to 16 lb-ft (16 to 22 Nm); tighten 12-in. impeller cover screws to 23 to 25 lb-ft (31 to 34 Nm).
39. Install turbine retaining ring (Figure 8, Item 8).
40. Position new O-ring (Figure 8, Item 7) on bore plug (Figure 8, Item 6) and install bore plug in impeller cover (Figure 8, Item 10).
41. Install retaining ring (Figure 8, Item 5).

**NOTE**

In step 42, two dimples 180 degrees apart in backing ring must be facing outward (toward engine flywheel).

42. Position drive plate assembly (Figure 8, Item 4), two drive plates (Figure 8, Item 3), and backing ring (Figure 8, Item 2) on impeller cover (Figure 8, Item 10).
43. Install 10 screws and new lockwashers (Figure 8, Item 1). Tighten screws to 23 to 25 lb-ft (31 to 34 Nm).

ASSEMBLY - CONTINUED

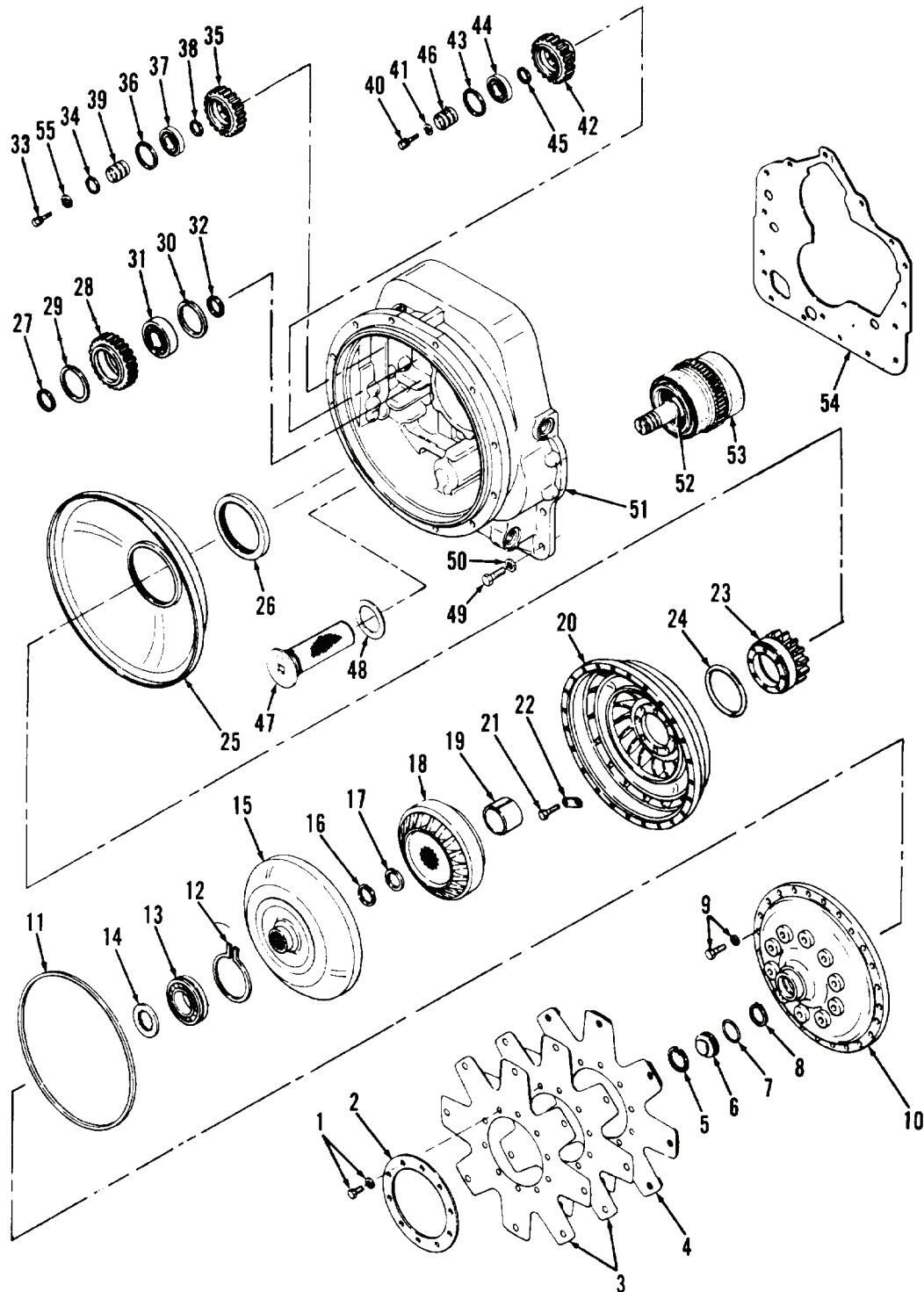

Figure 8. Torque Converter.

TA127299

**ASSEMBLY - CONTINUED**

44. Install control valve and modulation valve assemblies (WP 0250).
45. Install charging pump assembly (WP 0251).

**END OF TASK****END OF WORK PACKAGE**

---

## GENERAL SUPPORT MAINTENANCE INSTRUCTIONS

### TORQUE CONVERTER HOUSING REPAIR

Disassembly, Cleaning, Inspection, Assembly

---

#### INITIAL SETUP

##### Maintenance Level

General Support

##### Tools and Special Tools

Tool kit, general mechanic's (Item 15, WP 0309)  
Shop equipment, common no. 1 (Item 2, WP 0309)  
Collar-type bearing puller  
Mechanical puller (NSN 5120-00-423-1596)  
Sleeve, 2-in. diameter  
Sleeve, 2-1/8-in. diameter  
Soft hone

##### Materials/Parts

Cleaning compound, solvent (Item 10, WP 0310)  
Lubricating oil, OE/HDO-15/40 (Item 21, WP 0310)  
Rag, wiping (Item 26, WP 0310)  
RTV sealant (Item 31, WP 0310)  
Lockwashers (6)  
Piston ring (2)  
Retaining ring

##### Equipment Condition

Torque converter group disassembled (WP 0290)

---

**DISASSEMBLY**

1. At rear of torque converter housing (Figure 2, Item 32), straighten tabs of lockplate (Figure 2, Item 1).
2. Remove lockplate (Figure 2, Item 1), three screws (Figure 2, Item 2) and bearing retainer plate (Figure 2, Item 3).
3. Remove reverse idler gear (Figure 2, Item 4). Use puller.
4. Remove bearing assembly (Figure 2, Item 5). Use puller.
5. Remove forward clutch shaft pilot bearing (Figure 2, Item 6).
6. At front of torque converter housing (Figure 2, Item 32), spread ears of retaining ring (Figure 2, Item 7). Use spreader-type of retaining ring pliers.
7. Remove turbine shaft hub assembly (Figure 2, Item 8). Hold retaining ring ears (Figure 2, Item 7) open and tap turbine shaft hub assembly from torque converter housing (Figure 2, Item 32) as shown.

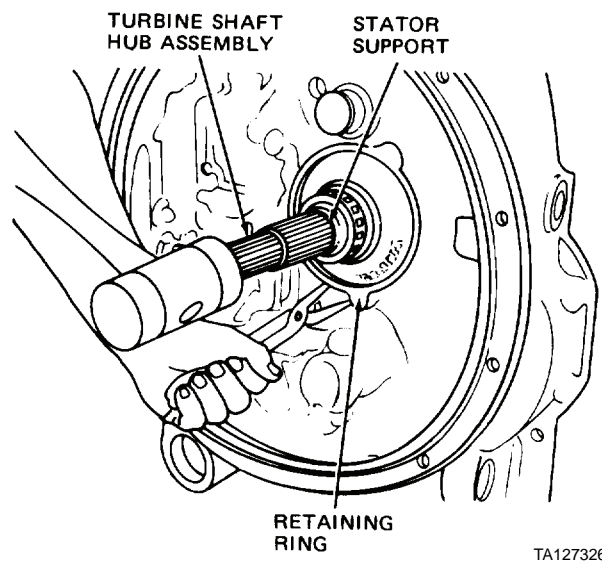

**Figure 1. Removing Turbine Shaft Hub Assembly.**

8. At turbine shaft hub assembly (Figure 2, Item 8), remove piston ring (Figure 2, Item 9) and retaining ring (Figure 2, Item 10). Discard piston ring.
9. Remove locating washer (Figure 2, Item 11) and bearing (Figure 2, Item 12) from turbine shaft hub assembly (Figure 2, Item 8). Use collar-type bearing puller.
10. At rear of torque converter housing (Figure 2, Item 32), remove six screws (Figure 2, Item 13) and lockwashers (Figure 2, Item 14). Discard lockwashers.
11. Remove stator support (Figure 2, Item 15). Tap at front and remove from rear of torque converter housing (Figure 2, Item 32).
12. Remove bearing (Figure 2, Item, 16), piston ring (Figure 2, Item 17), and expander spring (Figure 2, Item, 18) from stator support (Figure 2, Item 15). Use collar-type bearing puller. Discard piston ring.
13. Remove converter housing sleeve (Figure 2, Item, 19) from rear of torque converter housing (Figure 2, Item 32). Use slide-type hammer puller.
14. Remove transmission temperature switch (Figure 2, Item 20) and plug (Figure 2, Item 21).
15. Remove studs (Figure 2, Items 22 and 23) if damaged and replacement is required.

**DISASSEMBLY - CONTINUED****NOTE**

Perform steps 16 through 18 only if parts are damaged and require replacement.

16. Remove idler gear shaft (Figure 2, Item 24) and lock ball (Figure 2, Item 25). Tap at front and remove from rear of torque converter housing (Figure 2, Item 32).
17. Remove reverse idler gear shaft (Figure 2, Item 26). Pry from torque converter housing (Figure 2, Item 32).
18. Remove pin (Figure 2, Item 27) from reverse idler gear shaft (Figure 2, Item 26).
19. Remove pipe plugs (Figure 2, Items 28, 29, and 30) from torque converter housing (Figure 2, Item 32).
20. Remove breather (Figure 2, Item 31).

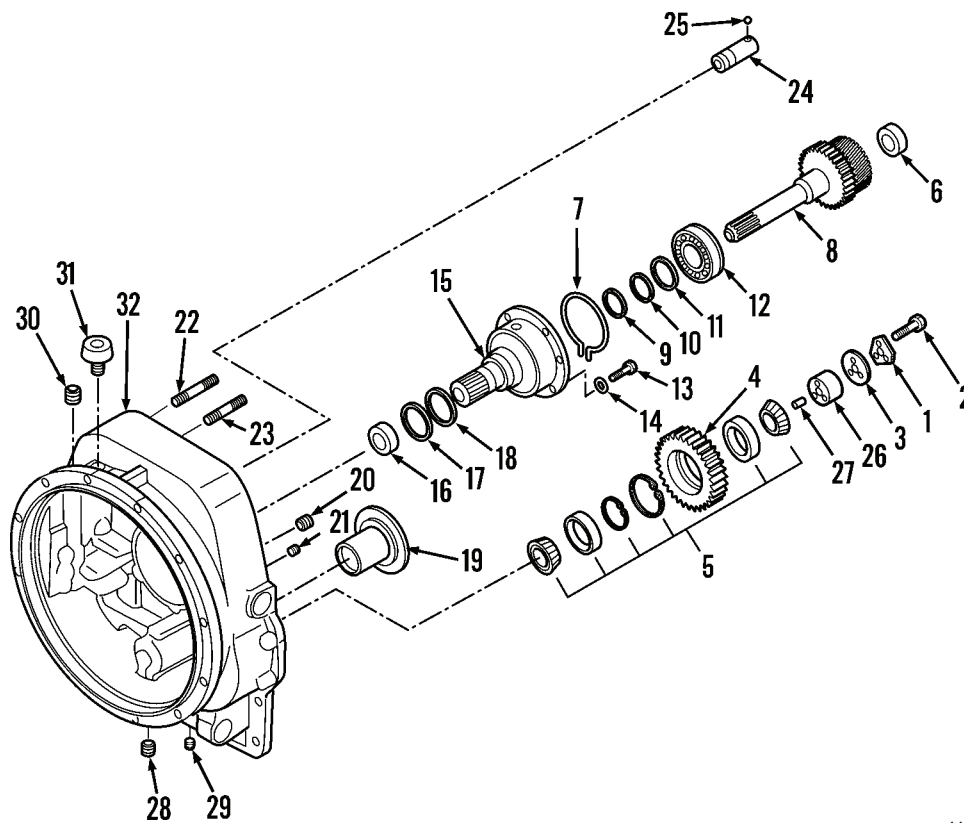

444-1405

**Figure 2. Torque Converter Housing.**

**END OF TASK**

**CLEANING****WARNING**

- Solvent cleaning compound MIL-PRF-680 Type III is an environmentally compliant and low toxic material. However, it may be irritating to the eyes and skin. Use protective gloves and goggles. Use in well-ventilated areas. Keep away from open flames and other sources of ignition. Failure to do so may result in injury or death to personnel.
  - Particles blown by compressed air are hazardous. DO NOT exceed 15 PSI (103 kPa) nozzle pressure when drying parts with compressed air. DO NOT direct compressed air against human skin. Make sure air stream is directed away from user and other personnel in the area. To prevent injury, user must wear protective goggles or face shield. Failure to follow this warning may result in injury to personnel.
1. Clean all parts with solvent cleaning compound. Immerse parts and move up and down slowly until all lubricant and foreign material is dissolved. Dry parts thoroughly after removal from solvent cleaning compound with compressed air or clean rags. Do not permit bearings to spin when drying with compressed air.
  2. Clean exterior of transmission temperature switch with clean rag moistened with solvent cleaning compound; dry using clean rag.

**END OF TASK****INSPECTION**

1. Inspect bearings for wear, chipping, or nicks. Do not replace a bearing cone or cup without replacing mating cup or cone at same time. After inspection dip bearing in clean, light oil and wrap in clean, lint-free rag or paper for protection until installed.
2. Inspect gears and shafts. Inspect gear teeth for wear, pitting, chipping nicks, cracks, or scores; replace if these defects are noted. If gear teeth show spot where case hardening is worn through or cracked, replace gear. Remove small nicks with suitable hone. Inspect shafts for bent, sprung, or twisted condition; replace if necessary. Inspect splines for wear or nicks; remove small nicks with a suitable hone.
3. Ensure housing is thoroughly cleaned and mating surfaces and bearing bores are free from nicks or burrs. Clean up using a soft hone. Check for cracks. If cracked, replace housing.
4. Inspect transmission temperature switch. Check body for damage and loose terminal. If damaged, replace switch.
5. Inspect all other parts. Replace if worn, cracked, or damaged.

**END OF TASK****ASSEMBLY**

1. Install breather (Figure 3, Item 31) on torque converter housing (Figure 3, Item 32).
2. Install pipe plugs (Figure 3, Items 28, 29, and 30).
3. At rear of torque convertor housing (Figure 3, Item 32), install pin (Figure 3, Item 27) and reverse idler gear shaft (Figure 3, Item 26), if removed. Tap into position with soft hammer.
4. Install idler gear shaft (Figure 3, Item 24) and lockball (Figure 3, Item 25), if removed. Place lockball in position on gear shaft. Then, insert gear shaft through its hole in rear of housing and tap into position with soft hammer.
5. Install studs (Figure 3, Items 22 and 23), if removed. Apply coat of sealing compound to threads before installing.
6. Install transmission temperature switch (Figure 3, Item 20) and pipe plug (Figure 3, Item 21) on torque converter housing (Figure 3, Item 32).



**ASSEMBLY - CONTINUED**

7. Position converter housing sleeve (Figure 3, Item 19) on torque converter housing (Figure 3, Item 32) with tab aligned with cast slot in converter housing. Press sleeve in until it shoulders in housing. Use 2-in. diameter bar stock.
8. Install expander spring (Figure 3, Item 18) on stator support (Figure 3, Item 15). Gap of expander spring must be 180 degrees from piston ring hook joint.
9. Install new piston ring (Figure 3, Item 17).

**NOTE**

In step 10, part number etched on bearing must face up.

10. Install bearing (Figure 3, Item 16). Press onto stator support (Figure 3, Item 15) using suitable size sleeve.
11. Install retaining ring (Figure 3, Item 7).
12. At rear of torque converter housing (Figure 3, Item 32), install stator support (Figure 3, Item 15). Align holes in stator support with converter housing holes, then tap stator support into position.
13. Install six screws (Figure 3, Item 13) and new lockwashers (Figure 3, Item 14) on stator support (Figure 3, Item 15). Tighten screws to 23 to 25 lb-ft (31 to 34 Nm).

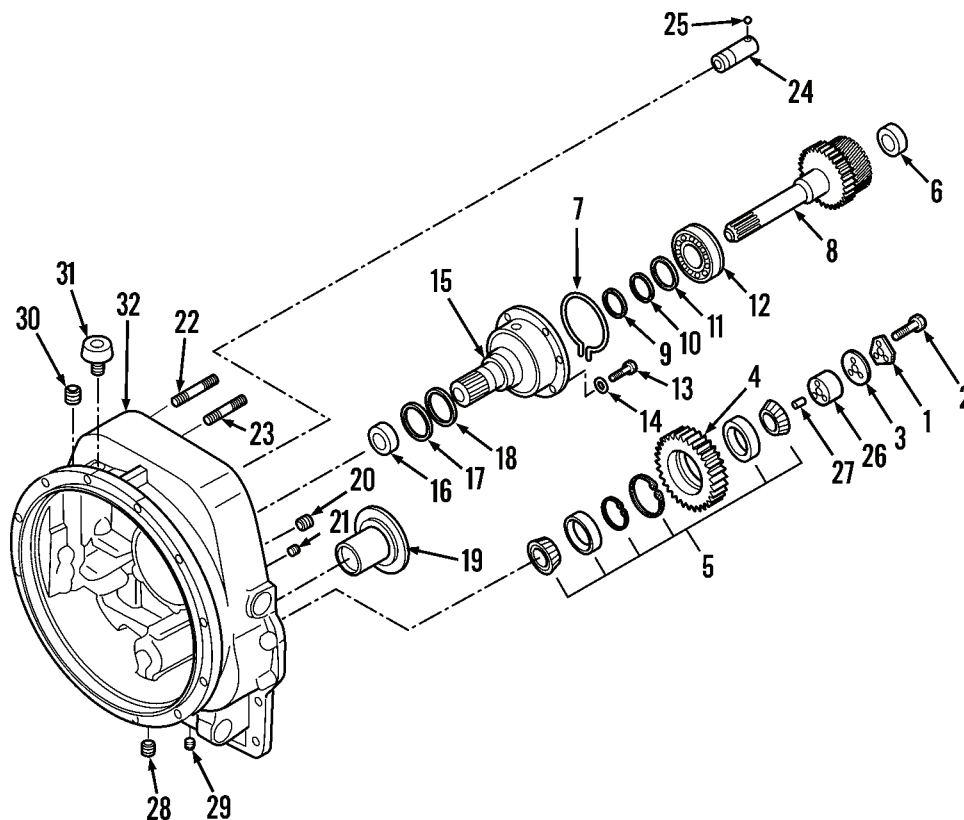

444-1405

**Figure 3. Torque Converter Housing.**

**ASSEMBLY - CONTINUED****NOTE**

In step 14, slot in bearing must be downward (opposite splined end of shaft).

14. At turbine shaft hub assembly (Figure 4, Item 8), install bearing (Figure 4, Item 12) using suitable size sleeve.
15. Install locating washer (Figure 4, Item 11), retaining ring (Figure 4, Item 10), and new piston ring (Figure 4, Item 9).
16. At rear of torque converter housing (Figure 4, Item 32), install turbine shaft hub assembly (Figure 4, Item 8). While spreading retaining ring ears (Figure 4, Item 7), tap turbine shaft hub assembly into position. Ensure retaining ring is fully engaged in slot of bearing (Figure 4, Item 12).
17. At reverse idler gear shaft (Figure 4, Item 26), place inner bearing, then bearing spacer, on idler gear shaft.
18. Position reverse idler gear (Figure 4, Item 4), with long hub out, on idler gear shaft (Figure 4, Item 26). Then, install outer taper bearing, which is part of bearing assembly (Figure 4, Item 5), into gear.
19. Install bearing retainer plate (Figure 4, Item, 3) and lockplate (Figure 4, Item, 1) on reverse idler gear shaft (Figure 4, Item 26) with three screws (Figure 4, Item 2). Tighten screws to 37 to 41 lb-ft (50 to 56 Nm), then bend lockplate tabs over head of each screw.
20. Position transmission forward clutch shaft pilot bearing (Figure 4, Item 6) in torque converter housing (Figure 4, Item 32).

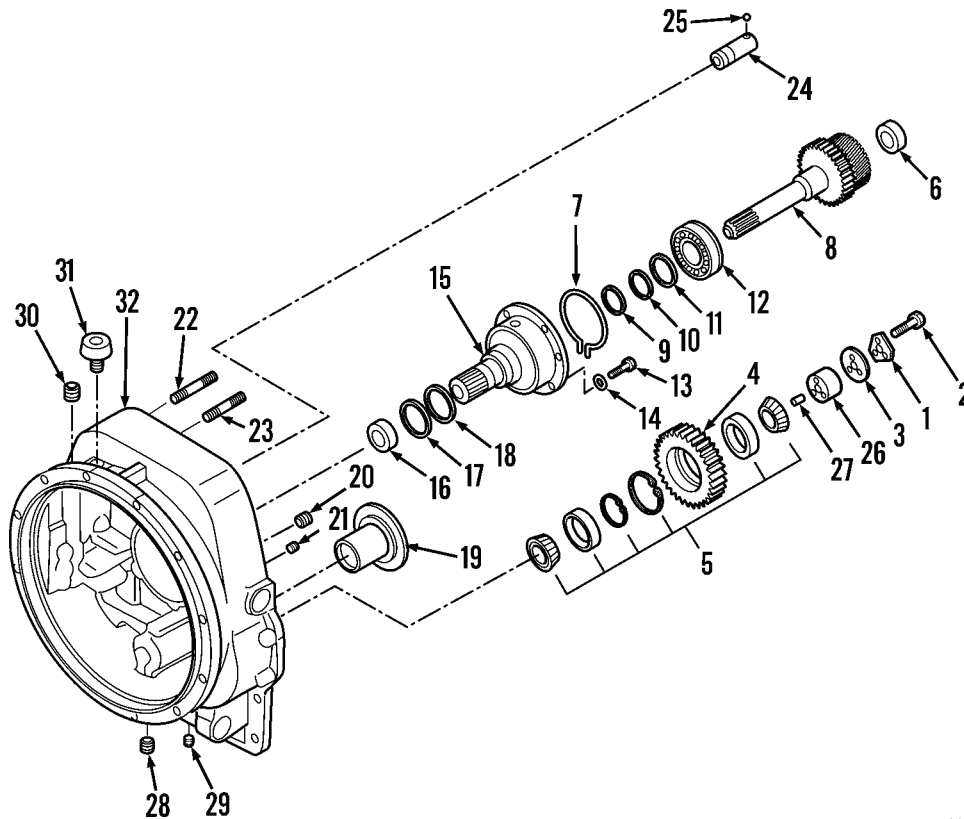

444-1405

**Figure 4. Torque Converter Housing.**

21. Assemble torque converter group (WP 0290).

**END OF TASK**

**END OF WORK PACKAGE**

---

# GENERAL SUPPORT MAINTENANCE INSTRUCTIONS

## TRANSMISSION REAR COVER REPLACEMENT

### Removal, Cleaning, Inspection, Installation

---

#### INITIAL SETUP

##### Maintenance Level

General Support

##### Tools and Special Tools

Tool kit, general mechanic's (Item 15, WP 0309)  
Shop equipment, common no. 1 (Item 2, WP 0309)  
Hot solution tank with mild alkali solution  
Pry bars (2)  
Soft hone

##### Materials/Parts

Cleaning compound, solvent (Item 10, WP 0310)  
Grease, automotive and artillery (Item 17, WP 0310)

##### Materials/Parts - Continued

Lubricating oil, OE/HDO-10 (Item 20, WP 0310)  
Permatex (Item 30, WP 0310)  
Rag, wiping (Item 26, WP 0310)  
Gasket  
Lockwasher (34)  
O-ring (6)  
Oil seal

##### Equipment Condition

Parking brake removed (WP 0162)  
Transmission separated from engine (WP 0213 or WP 0214)

---

**REMOVAL**

1. Remove four nuts (Figure 1, Item 1) and lockwashers (Figure 1, Item 2) from low shaft rear bearing cap (Figure 1, Item 3). Discard lockwashers.
2. Remove plug (Figure 1, Item 5) from low shaft rear bearing cap (Figure 1, Item 3).
3. Remove low shaft rear bearing cap (Figure 1, Item 3).
4. Remove O-rings (Figure 1, Items 4 and 6) from rear cover assembly and discard.
5. Remove four nuts (Figure 1, Item 7) and lockwashers (Figure 1, Item 8) from idler shaft bearing cap (Figure 1, Item 9). Discard lockwashers.
6. Remove idler shaft bearing cap (Figure 1, Item 9) and O-ring (Figure 1, Item 10) from rear cover (Figure 1, Item 29). Discard O-ring.
7. Remove four nuts (Figure 1, Item 11) and lockwashers (Figure 1, Item 12) from output shaft bearing cap (Figure 1, Item 13). Discard lockwashers.
8. Remove output shaft bearing cap (Figure 1, Item 13) from rear cover (Figure 1, Item 29).
9. Remove O-rings (Figure 1, Items 14 and 15) from output shaft bearing cap (Figure 1, Item 13). Discard O-rings.
10. Remove bearing-to-flange spacer (Figure 1, Item 16) and rear bearing cap oil seal (Figure 1, Item 17) from output shaft bearing cap (Figure 1, Item 13). Discard rear bearing cap oil seal.
11. Remove detent plug (Figure 1, Item 18), mesh lock ball (Figure 1, Item 19), and mesh lock spring (Figure 1, Item 20) from high and low shift rail support (Figure 1, Item 23).
12. Remove two nuts (Figure 1, Item 21) and lockwashers (Figure 1, Item 22) from high and low shift rail support (Figure 1, Item 23). Discard lockwashers.
13. Remove high and low shift rail support (Figure 1, Item 23) and shift rail oil seal (Figure 1, Item 24) from rear cover (Figure 1, Item 29). Discard shift rail oil seal.
14. Remove O-ring (Figure 1, Item 25) from high and low shift rail support (Figure 1, Item 23). Discard O-ring.
15. Remove plug (Figure 1, Item 26) from rear cover (Figure 1, Item 29).
16. Remove 20 capscrews (Figure 1, Item 27) and lockwashers (Figure 1, Item 28) from rear cover (Figure 1, Item 29). Discard lockwashers.
17. Remove three locating rings (Figure 1, Item 35) from rear cover (Figure 1, Item 29).
18. Use pry slots provided to pry rear cover (Figure 1, Item 29) from transmission housing. Use a soft hammer to tap on low clutch, idler, and output shafts to prevent rear cover from binding.
19. Remove rear cover-to-case gasket (Figure 1, Item 30) and discard. Clean all traces of gasket material from transmission case.

## REMOVAL - CONTINUED

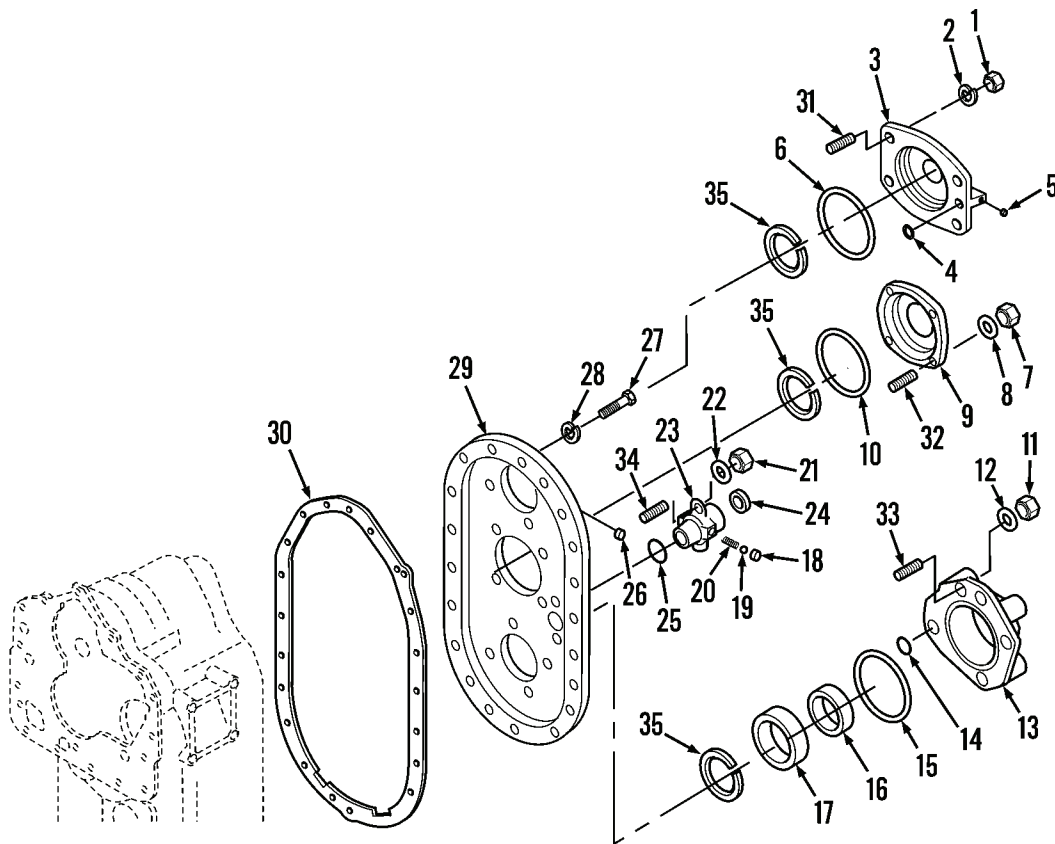

Figure 1. Transmission Rear Cover.

444-1414

## END OF TASK

## CLEANING



WARNING



- Exercise care when using alkali cleaners to avoid coming in contact with cleaner or breathing vapors to prevent skin rashes and bodily harm. Wear a rubber apron to prevent clothes from coming in contact with cleaner and use cleaner in a well ventilated area. If alkali cleaner is splashed on clothes or skin, flood area with large amounts of water and get immediate medical attention. Failure to do so may result in injury to personnel.
- Particles blown by compressed air are hazardous. DO NOT exceed 15 PSI (103 kPa) nozzle pressure when drying parts with compressed air. DO NOT direct compressed air against human skin. Make sure air stream is directed away from user and other personnel in the area. To prevent injury, user must wear protective goggles or face shield. Failure to follow this warning may result in injury to personnel.

Clean interior and exterior of parts in hot solution tank with a mild alkali solution. Allow parts to remain in solution long enough to be cleaned and heated. Thoroughly rinse parts with clean water to remove all traces of alkali. Dry parts thoroughly immediately using moisture-free compressed air or clean rags.

## END OF TASK

## INSPECTION

1. Inspect studs (Figure 2, Items 31, 32, 33, and 34) on rear cover (Figure 2, Item 29). Check for damaged threads and bent condition. Repair damaged threads by chasing with proper size die; replace bent studs.
2. Inspect rear cover (Figure 2, Item 29), bearing caps (Figure 2, Items 3, 9, and 13) and high and low shift rail support (Figure 2, Item 23). Ensure all traces of gasket material are removed from mating surface of rear cover. Ensure mating surfaces and bores are free from nicks or burrs and cracks are not evident. Remove burrs with a soft hone; if nicks or cracks are observed, replace part.
3. Inspect bearing-to-flange spacer (Figure 2, Item 16). Replace if surfaces worn or deformed.
4. Inspect mesh lock ball (Figure 2, Item 19). Replace if deformed or damaged.
5. Inspect mesh lock spring (Figure 2, Item 20). Replace if cracked, broken, deformed, or permanently set.

## END OF TASK

## INSTALLATION

1. Position new rear cover-to-case gasket (Figure 2, Item 30) on rear of transmission housing. Install two aligning studs in transmission housing to facilitate positioning of gasket and installation of rear cover (Figure 2, Item 29). Apply thin coat of GAA grease to hold gasket in place.

## CAUTION

Before performing step 2, move forward range shift hub on output shaft. Pulling on high and low shift rail may cause hub to fall off.

2. Position rear cover (Figure 2, Item 29) on transmission housing. Tap rear cover in place, aligning shaft bearings with bearing bores in cover.
3. Install 20 new lockwashers (Figure 2, Item 28) and capscrews (Figure 2, Item 27). Remove two aligning studs after several lockwashers and capscrews are installed. Tighten capscrews to 37 to 41 lb-ft (50 to 56 Nm).
4. Install three locating rings (Figure 2, Item 35) on rear cover (Figure 2, Item 29).
5. Install new shift rail oil seal (Figure 2, Item 24) on high and low shift rail. Apply thin coat of Permatex 2 on outer diameter of oil seal then press into support with lip of oil seal toward rear cover. Use clean engine oil to lubricate oil seal toward rear cover.
6. Use GAA grease to lubricate new O-ring (Figure 2, Item 25) and install on high and low shift rail support (Figure 2, Item 23).
7. Install mesh lock spring (Figure 2, Item 20) on high and low shift rail support (Figure 2, Item 23).
8. Use GAA grease to lubricate mesh lock spring (Figure 2, Item 20) and ball (Figure 2, Item 19) and install on high and low shift rail support (Figure 2, Item 23).
9. Install high and low shift rail support (Figure 2, Item 23) on rear cover (Figure 2, Item 29). Place small diameter long screw through high and low shift rail support to hold ball (Figure 2, Item 19) in depressed position, against mesh lock spring (Figure 2, Item 20). Place high and low shift rail support on high and low shift rail with screw upward, until flat of shift rail catches ball. Then, remove small diameter long screw from high and low shift rail support. Push high and low shift rail support while also turning it, until seated against rear cover.
10. Install two new lockwashers (Figure 2, Item 22) and nuts (Figure 2, Item 21) on high and low shift rail support (Figure 2, Item 23). Tighten nuts to 41 to 45 lb-ft (56 to 61 Nm).
11. Install detent plug (Figure 2, Item 18) on high and low shift rail support (Figure 2, Item 23).
12. Install new rear bearing cap oil seal (Figure 2, Item 17) on output shaft bearing cap (Figure 2, Item 13). Use clean engine oil to lubricate rear bearing cap oil seal. Apply thin coat of Permatex 2 on outer diameter of oil seal, then press into bearing cap with lip of seal toward bearing side of cap.

**INSTALLATION - CONTINUED**

13. Use clean engine oil to lubricate new O-rings (Figure 2, Items 14 and 15) and install O-rings on output shaft bearing cap (Figure 2, Item 13).
14. Position bearing-to-flange spacer (Figure 2, Item 16) on output shaft.
15. Position output shaft bearing cap (Figure 2, Item 13) on rear cover (Figure 2, Item 29).
16. Install four new lockwashers (Figure 2, Item 12) and nuts (Figure 2, Item 11). Tighten nuts to 91 to 100 lb-ft (123 to 136 Nm).
17. Use clean engine oil to lubricate new O-ring (Figure 2, Item 10) and install on idler shaft bearing cap (Figure 2, Item 9).
18. Position idler shaft bearing cap (Figure 2, Item 9) on rear cover (Figure 2, Item 29) and install four new lockwashers (Figure 2, Item 8) and nuts (Figure 2, Item 7). Tighten nuts to 41 to 45 lb-ft (56 to 61 Nm).
19. Use clean engine oil to lubricate new O-rings (Figure 2, Items 4 and 6) and install on low shaft rear bearing cap (Figure 2, Item 3).
20. Position low shaft rear bearing cap (Figure 2, Item 3) on rear cover (Figure 2, Item 29) and install four new lockwashers (Figure 2, Item 2) and nuts (Figure 2, Item 1). Tighten nuts to 41 to 45 lb-ft (56 to 61 Nm).
21. Install plug (Figure 2, Item 26) on rear cover (Figure 2, Item 29).

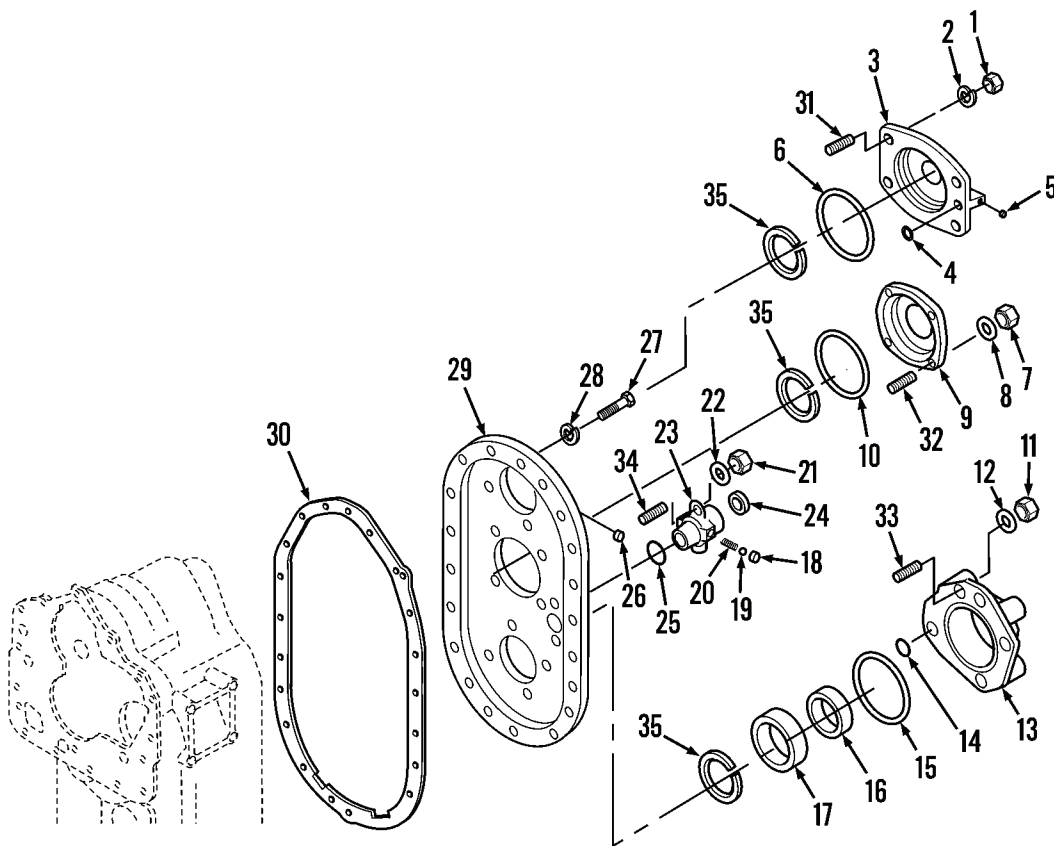
**Figure 2. Transmission Rear Cover.**

444-1414

22. Install parking brake (WP 0162).

**END OF TASK****END OF WORK PACKAGE**





---

# GENERAL SUPPORT MAINTENANCE INSTRUCTIONS

## TRANSMISSION GEARS AND CLUTCHES REPAIR

Disassembly, Cleaning, Inspection, Assembly

---

### INITIAL SETUP

#### Maintenance Level

General Support

#### Tools and Special Tools

Tool kit, general mechanic's (Item 15, WP 0309)  
Shop equipment, common no. 1 (Item 2, WP 0309)  
Arbor press, 1/2-ton capacity  
Impact wrench (NSN 5130-00-596-9821)  
Mechanical puller (NSN 5120-00-423-1596)  
Snap ring pliers, contracting type (NSN 5120-00-293-0046)  
Soft bar, 18 in. long x 2 in. OD  
Soft hone

#### Personnel Required

Two

#### References

WP 0296

#### References - Continued

WP 0297

WP 0298

#### Materials/Parts

Cleaning compound, solvent (Item 10, WP 0310)  
Lubricating oil, OE/HDO-10 (Item 20, WP 0310)  
Permatex (Item 30, WP 0310)  
Rag, wiping (Item 26, WP 0310)  
Flange nut  
Locating ring (2)  
Oil seal  
O-ring  
Retaining ring (7)

#### Equipment Condition

Torque converter group disassembled (WP 0290)  
Transmission rear cover removed (WP 0292)

---

**DISASSEMBLY**

1. Remove low shaft piston ring (Figure 1, Item 1) from transmission housing.
2. Remove retaining ring (Figure 1, Item 2) from transmission housing and discard.
3. Remove support washer (Figure 1, Item 3) from transmission housing.
4. Use puller to remove low speed shaft rear bearing (Figure 1, Item 4) from transmission housing.
5. Remove idler shaft and gear (Figure 1, Item 5) and associated parts (Figure 1, Items 6 through 8) as an assembly from transmission housing.
6. Remove retaining ring (Figure 1, Item 6) from idler shaft and gear (Figure 1, Item 5) and discard.
7. Remove support washer (Figure 1, Item 7) from idler shaft and gear (Figure 1, Item 5).
8. Use puller to remove idler shaft rear bearing (Figure 1, Item 8).
9. Remove flange nut (Figure 1, Item 9) from output shaft (Figure 1, Item 33). Use impact wrench; if unavailable, use a bar to hold output flange (Figure 1, Item 12). Discard flange nut.
10. Remove flange washer (Figure 1, Item 10) from output flange (Figure 1, Item 12).
11. Remove O-ring (Figure 1, Item 11) from output flange (Figure 1, Item 12) and discard.
12. Use puller to remove output flange (Figure 1, Item 12) from output shaft (Figure 1, Item 33).
13. Remove reverse and second clutch rear bearing (Figure 1, Item 13) from reverse and second clutch assembly bore in front of transmission housing.
14. Remove retaining ring (Figure 1, Item 14) from reverse and second clutch assembly bore in front of transmission housing and discard.
15. Remove second clutch disc hub (Figure 1, Item 15) from reverse and second clutch assembly bore in front of transmission housing.
16. Compress protruding ends of third clutch front bearing locating ring (Figure 1, Item 16) and remove from ring groove. Do not remove ring from third clutch assembly.

**CAUTION**

In step 17, have an assistant hold low clutch assembly on opposite side of transmission housing to prevent assembly from dropping out of transmission housing.

17. Use soft bar to tap low clutch assembly (Figure 1, Item 17) from rear of transmission housing.

**NOTE**

Refer to WP 0296 to disassemble low clutch assembly.

18. Use contracting type snap ring pliers and lock in position to hold bearing carrier locating ring (Figure 1, Item 18) at rear of transmission housing.

**NOTE**

If third clutch assembly is difficult to remove, recheck front and rear locating rings to ensure they are clear of ring groove.

19. Use soft bar to tap third clutch assembly (Figure 1, Item 19) from front of transmission housing.
20. Remove locating ring, bearing carrier, and associated parts (Figure 1, Items 21 through 26) from bearing carrier (Figure 1, Item 20) as an assembly.
21. Remove bearing carrier locating ring (Figure 1, Item 18) from bearing carrier (Figure 1, Item 20) and discard.
22. Remove third clutch shaft pilot bearing (Figure 1, Item 21) from bearing carrier (Figure 1, Item 20).
23. Remove retaining ring (Figure 1, Item 22) from bearing carrier (Figure 1, Item 20) and discard.
24. Use sleeve to remove third clutch disc hub (Figure 1, Item 23) from bearing carrier (Figure 1, Item 20).
25. Remove retaining ring (Figure 1, Item 24) from bearing carrier (Figure 1, Item 20) and discard.

**DISASSEMBLY - CONTINUED**

26. Remove third clutch disc hub bearing (Figure 1, Item 25) from bearing carrier (Figure 1, Item 20).
27. Remove locating ring (Figure 1, Item 26) from bearing carrier (Figure 1, Item 20) and discard.
28. Remove third clutch assembly (Figure 1, Item 19) from transmission housing.

**NOTE**

Refer to WP 0297 to repair third clutch assembly.

29. Remove roll pin (Figure 1, Item 28) from piston ring outer race (Figure 1, Item 27).
30. Remove high and low shift fork (Figure 1, Item 29) and associated parts (Figure 1, Items 30 through 32) as an assembly; disengage from range shift hub (Figure 1, Item 40).
31. Remove lock screw (Figure 1, Item 30), high and low shift rail (Figure 1, Item 31), and spacer (Figure 1, Item 32) from high and low shift fork (Figure 1, Item 29).
32. Remove output shaft (Figure 1, Item 33) and associated parts (Figure 1, Items 34 through 42) as an assembly from transmission housing.
33. Use puller to remove output shaft front bearing (Figure 1, Item 34) from output shaft (Figure 1, Item 33).
34. Remove thrust washer (Figure 1, Item 35) from output shaft (Figure 1, Item 33).
35. Use puller to remove low range gear (Figure 1, Item 36) from output shaft (Figure 1, Item 33).

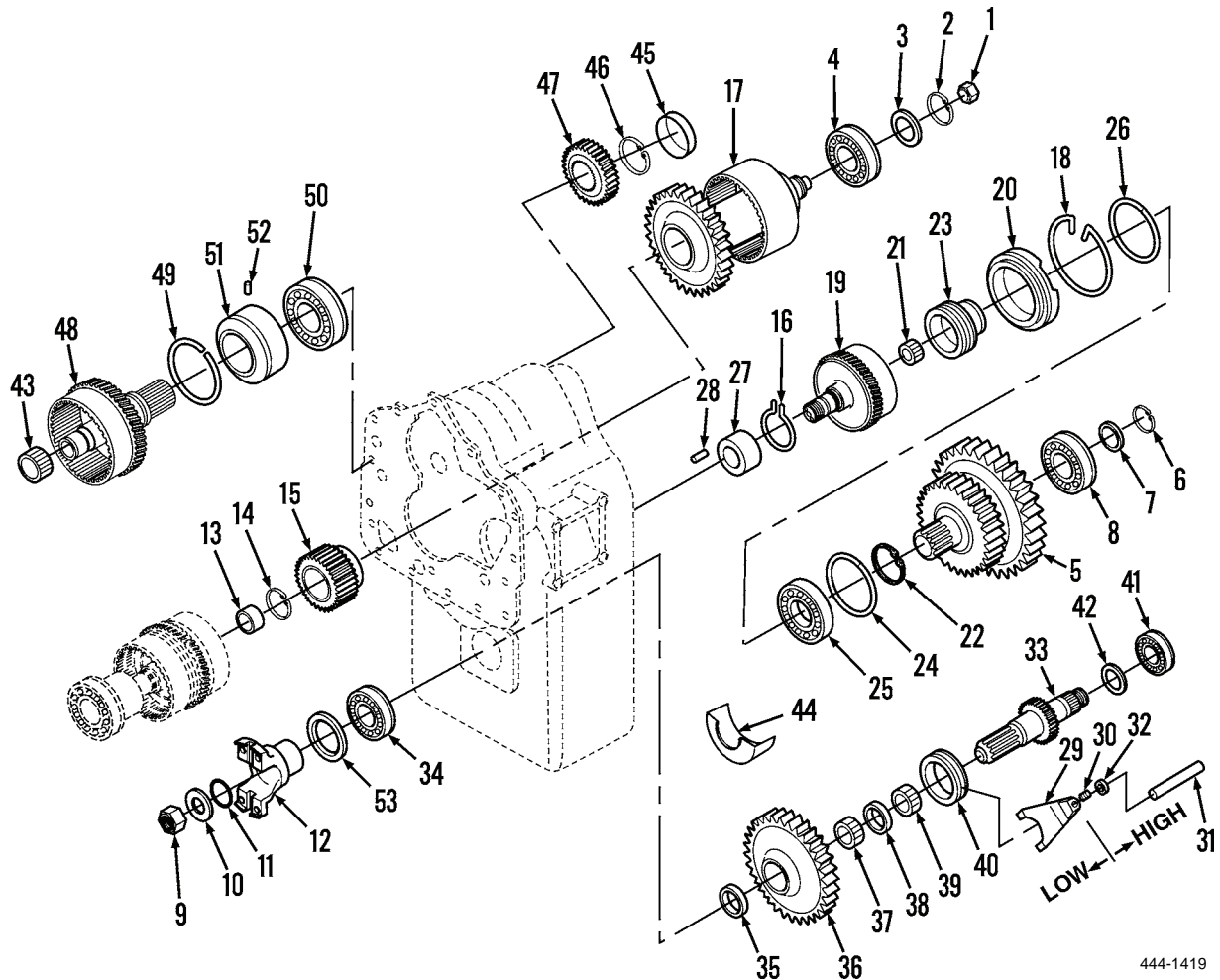

444-1419

**Figure 1. Transmission Gears and Clutches.**

**DISASSEMBLY - CONTINUED****NOTE**

If low gear bearings and bearing spacer remain in low range gear, use sleeve to remove.

36. Remove low gear bearing (Figure 2, Item 37) from output shaft (Figure 2, Item 33).
37. Remove bearing spacer (Figure 2, Item 38) from output shaft (Figure 2, Item 33).
38. Remove low gear bearing (Figure 2, Item 39) from output shaft (Figure 2, Item 33).
39. Remove range shift hub (Figure 2, Item 40) from output shaft (Figure 2, Item 33).
40. Use puller to remove output shaft rear bearing (Figure 2, Item 41) from output shaft (Figure 2, Item 33).
41. Remove gear thrust washer (Figure 2, Item 42) from output shaft (Figure 2, Item 33).
42. Remove forward shaft pilot bearing (Figure 2, Item 43) from transmission housing.
43. Remove oil baffle (Figure 2, Item 44) from transmission housing.

**CAUTION**

In step 44, take care not to damage bore in transmission housing.

44. Remove bore plug (Figure 2, Item 45) from transmission housing by carefully prying.
45. Remove retaining ring (Figure 2, Item 46) from transmission housing and discard.
46. Remove forward shaft gear (Figure 2, Item 47) from transmission housing.
47. Use soft bar to tap forward clutch assembly (Figure 2, Item 48) from front of transmission housing.

**NOTE**

Refer to WP 0298 for repair of forward clutch assembly.

48. Remove retaining ring (Figure 2, Item 49) from transmission housing and discard.
49. Use soft bar to tap forward shaft rear bearing (Figure 2, Item 50) from rear of transmission housing.
50. Remove piston ring sleeve (Figure 2, Item 51) from transmission housing.
51. Remove roll pin (Figure 2, Item 52) from piston ring sleeve (Figure 2, Item 51).
52. Use sleeve and tap output shaft oil seal (Figure 2, Item 53) out from front of transmission housing. Discard output shaft oil seal.

DISASSEMBLY - CONTINUED

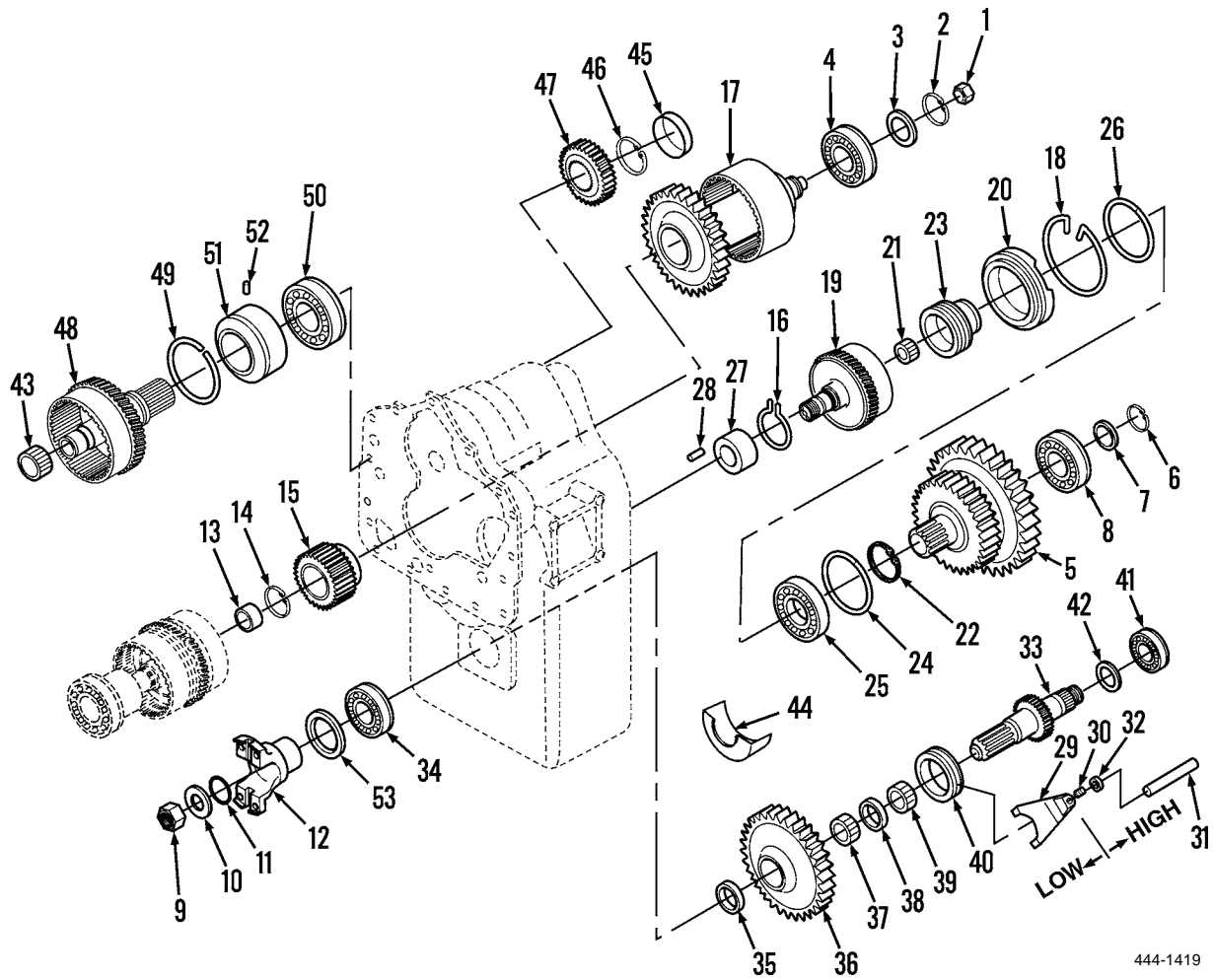

Figure 2. Transmission Gears and Clutches.

END OF TASK

**CLEANING****WARNING**

- Solvent cleaning compound MIL-PRF-680 Type III is an environmentally compliant and low toxic material. However, it may be irritating to the eyes and skin. Use protective gloves and goggles. Use in well-ventilated areas. Keep away from open flames and other sources of ignition. Failure to do so may result in injury or death to personnel.
  - Particles blown by compressed air are hazardous. DO NOT exceed 15 PSI (103 kPa) nozzle pressure when drying parts with compressed air. DO NOT direct compressed air against human skin. Make sure air stream is directed away from user and other personnel in the area. To prevent injury, user must wear protective goggles or face shield. Failure to follow this warning may result in injury to personnel.
1. Use solvent cleaning compound to clean bearings (Figure 3, Items 4, 8, 13, 21, 25, 34, 37, 39, 41, 43, and 50). Immerse bearings in cleaning solvent and move slowly up and down. Remove bearings. Strike larger side of cone against block of wood to dislodge solidified particles of lubricant. Immerse again in solvent cleaning compound. Repeat process until bearings are thoroughly clean. Dry using moisture-free compressed air. Direct air stream across bearing. Do not spin bearings when drying. Rotate bearings slowly by hand to facilitate drying.

**CAUTION**

Do not immerse low clutch assembly, third clutch assembly, or forward clutch assembly in cleaning solvent. Doing so could damage clutch assemblies.

**NOTE**

If low clutch assembly, third clutch assembly, and forward clutch assembly have been repaired, do not perform step 2.

2. Use clean rags moistened with solvent cleaning compound to remove exterior oil and/or dirt from low clutch assembly (Figure 3, Item 17), third clutch assembly (Figure 3, Item 19) and forward clutch assembly (Figure 3, Item 48), then dry with clean rags.
3. Use solvent cleaning compound. Immerse parts in cleaning solvent and move slowly up and down until parts are thoroughly cleaned. Dry thoroughly using moisture-free compressed air or clean rags.
4. Inspect all rollers, cages, and cups of bearings (Figure 3, Items 4, 8, 13, 21, 25, 34, 37, 39, 41, 43, and 50) for wear, chips, nicks, cracks, damage, and distortion. If any of these conditions are observed, replace bearing. After inspection, immerse in clean light oil and wrap in clean lint-free cloth or paper.
5. Inspect teeth on idler shaft and gear (Figure 3, Item 5), low range gear (Figure 3, Item 36), and forward shaft gear (Figure 3, Item 47) for wear, pits, nicks, cracks, and scores. Remove small nicks with hone. Inspect overall for damage, distortion, and cracks. If any of these conditions are observed, replace gear.
6. Inspect output shaft (Figure 3, Item 33) for bent condition. Ensure splines are not twisted or chipped. If shaft is worn or any of these conditions are observed, replace output shaft.
7. Inspect output flange (Figure 3, Item 12) and range shift hub (Figure 3, Item 40) for bent or worn condition. Ensure internal splines are not bent or chipped; if any of these conditions observed, replace part.
8. Inspect all other parts for wear, cracks, distortion, pits, nicks, scores, and damage. If any of these conditions are observed, replace part.

**END OF TASK**

**ASSEMBLY**

1. Use clean engine oil to lubricate new output shaft oil seal (Figure 3, Item 53), then apply thin coat of Permatex 2 on outer diameter of oil seal. Install oil seal using sleeve. Oil seal is properly installed when seal is flush with front of transmission housing.

**NOTE**

Bearing snap ring groove faces front of transmission housing.

2. Tap forward shaft rear bearing (Figure 3, Item 50) into transmission housing.
3. Install roll pin (Figure 3, Item 52) in piston ring sleeve (Figure 3, Item 51).
4. Align pin (Figure 3, Item 52) in piston ring sleeve (Figure 3, Item 51) with groove in transmission housing, then tap sleeve into position.
5. Install new retaining ring (Figure 3, Item 49) on piston ring sleeve (Figure 3, Item 51).

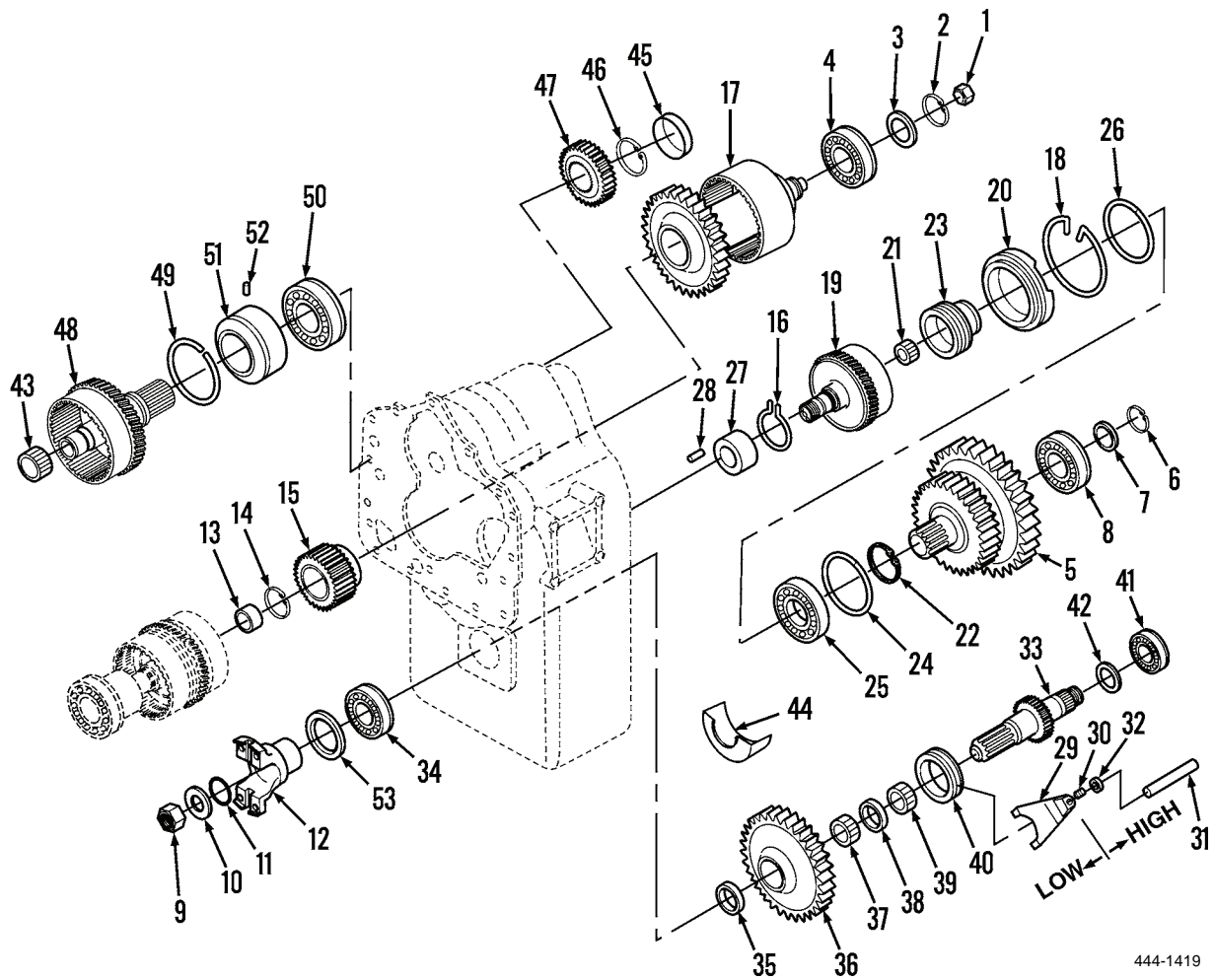

**Figure 3. Transmission Gears and Clutches.**

**ASSEMBLY - CONTINUED****CAUTION**

In step 6, do not damage forward shaft piston rings.

6. Use soft hammer and tap forward clutch assembly (Figure 4, Item 48) into position.
7. Install forward shaft pilot bearing (Figure 4, Item 43).
8. Position forward shaft gear (Figure 4, Item 47) at forward clutch bore in transmission housing.
9. Use retaining ring pliers to install new retaining ring (Figure 4, Item 46) on forward shaft gear (Figure 4, Item 47).
10. Tap bore plug (Figure 4, Item 45) into position until flush with outside of transmission housing.
11. Install new locating ring (Figure 4, Item 26) on bearing carrier (Figure 4, Item 20).
12. Press third clutch disc hub bearing (Figure 4, Item 25) into bearing carrier (Figure 4, Item 20) against locating ring (Figure 4, Item 26).
13. Install new retaining ring (Figure 4, Item 24) in transmission housing.
14. Press third clutch disc hub (Figure 4, Item 23) into bearing (Figure 4, Item 25).
15. Install retaining ring (Figure 4, Item 22) in transmission housing.
16. Install new bearing carrier locating ring (Figure 4, Item 18) in bearing carrier (Figure 4, Item 20).
17. Install third clutch shaft pilot bearing (Figure 4, Item 21) in transmission housing.

**CAUTION**

Do not force operation in step 18.

18. Position bearing carrier (Figure 4, Item 20) on third clutch assembly (Figure 4, Item 19). Align disc hub (Figure 4, Item 23) splines with internal teeth of disc in third clutch assembly. Disc hub splines must be in full position with internal teeth of all discs.
19. Position third clutch front bearing locating ring (Figure 4, Item 16) on third clutch assembly (Figure 4, Item 19).
20. Install outer race roll pin (Figure 4, Item 28) in outer race (Figure 4, Item 27).
21. Install piston ring outer race (Figure 4, Item 27) in transmission housing.
22. Position bearing carrier locating ring (Figure 4, Item 18) in transmission housing. Use contracting type snap ring pliers to contract bearing carrier locating ring and lock pliers to hold ring in position.
23. Position third clutch assembly (Figure 4, Item 19) and bearing carrier (Figure 4, Item 20) and tap assembly into transmission housing until ring groove in transmission housing is aligned with locating ring (Figure 4, Item 18). Remove pliers.
24. Ensure bearing carrier locating ring (Figure 4, Item 18) is in full position in ring groove.
25. Install oil baffle (Figure 4, Item 44) in transmission housing.
26. Use soft hammer to install low gear bearing (Figure 4, Item 37) until flush with low range gear (Figure 4, Item 36).
27. Use soft hammer to install bearing spacer (Figure 4, Item 38) until flush with bearing (Figure 4, Item 37).
28. Use soft hammer to install low gear bearing (Figure 4, Item 39) until flush with gear (Figure 4, Item 36) hub.



**ASSEMBLY - CONTINUED**

29. Install range shift hub (Figure 4, Item 40) on output shaft (Figure 4, Item 33).
30. Install gear thrust washer (Figure 4, Item 42) with bevel towards rear cover.
31. Press output shaft rear bearing (Figure 4, Item 41) onto output shaft until bearing shoulders on washer (Figure 4, Item 42).
32. Press low range gear (Figure 4, Item 36) onto output shaft.
33. Install thrust washer (Figure 4, Item 35) in transmission housing.
34. Press output shaft front bearing (Figure 4, Item 34) onto output shaft until bearing shoulders on thrust washer (Figure 4, Item 35).
35. Install output shaft (Figure 4, Item 33) in transmission housing.

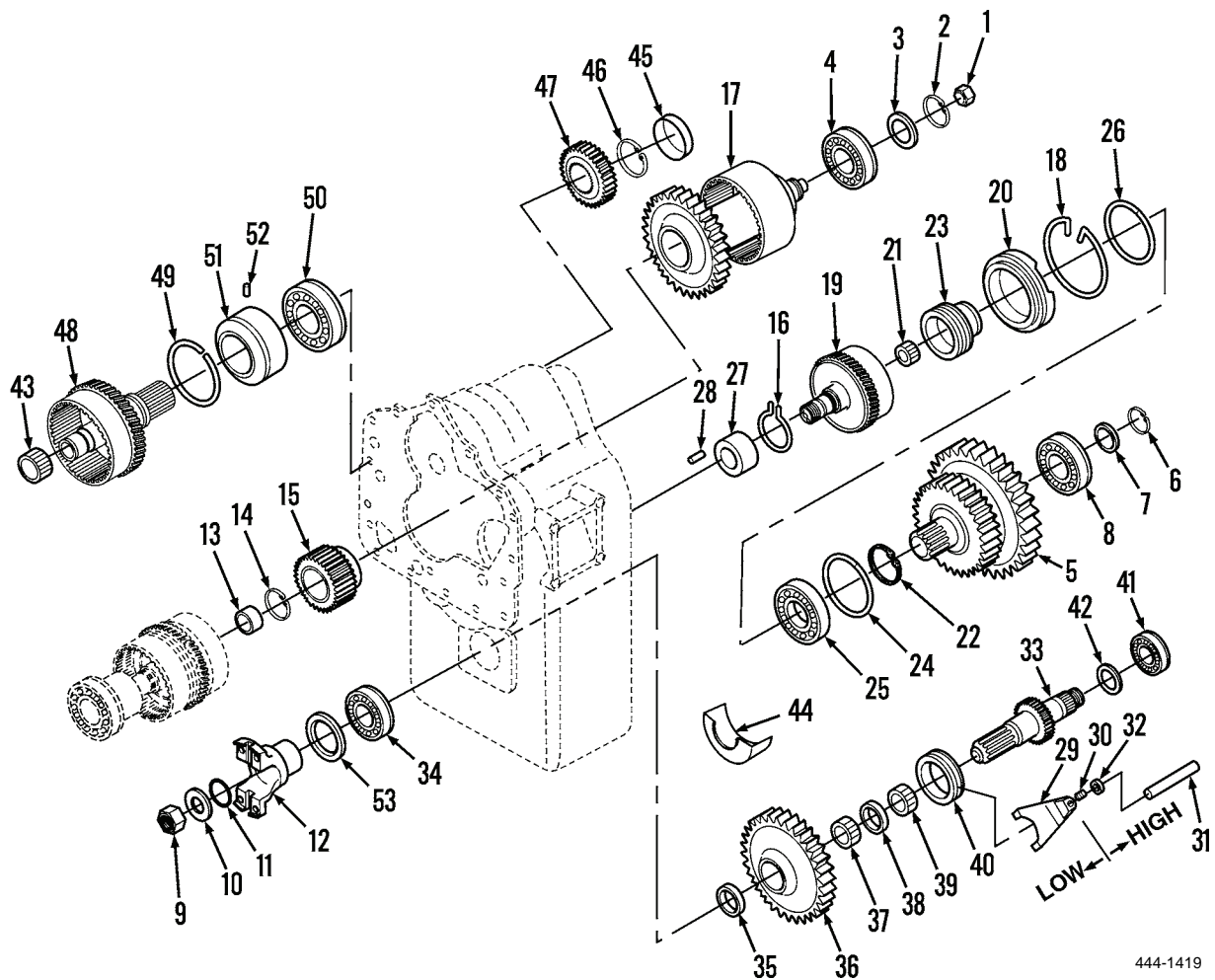

444-1419

**Figure 4. Transmission Gears and Clutches.**

**ASSEMBLY - CONTINUED**

36. Install spacer (Figure 5, Item 32) on high and low shift rail (Figure 5, Item 31).
37. Install high and low shift rail (Figure 5, Item 31) on high and low shift fork (Figure 5, Item 29).
38. Install lock screw (Figure 5, Item 30) on high and low shift fork (Figure 5, Item 29).
39. Install high and low shift fork (Figure 5, Item 29) in transmission housing and engage forks in range shift hub (Figure 5, Item 40) race.
40. Install third clutch front bearing locating ring (Figure 5, Item 16) into ring groove.

**NOTE**

Be certain locating ring is in full position in ring groove.

41. Tap low clutch assembly (Figure 5, Item 17) into position in low clutch bore in rear of transmission housing.
42. Install second clutch disc hub (Figure 5, Item 15) on low clutch shaft.
43. Install new retaining ring (Figure 5, Item 14) in front of transmission housing.
44. Install reverse and second clutch rear bearing (Figure 5, Item 13) in front of transmission housing.
45. Install output flange (Figure 5, Item 12) on output shaft (Figure 5, Item 33).

**NOTE**

Lubricate with OE10 (refer to current lubrication order).

46. Install new O-ring (Figure 5, Item 11) on output flange (Figure 5, Item 12).
47. Install flange washer (Figure 5, Item 10) on output flange (Figure 5, Item 12).
48. Install new flange nut (Figure 5, Item 9) and tighten to 200-250 lb-ft torque.
49. Press idler shaft rear bearing (Figure 5, Item 8) into idler shaft and gear (Figure 5, Item 5).
50. Install support washer (Figure 5, Item 7) and new retaining ring (Figure 5, Item 6) in rear of transmission housing.

**NOTE**

In the following step, carefully align splines of idler shaft and gear with splines of third clutch assembly.

51. Install idler shaft and gear (Figure 5, Item 5) in end of third clutch assembly.
52. Install low speed shaft rear bearing (Figure 5, Item 4) on low clutch shaft with ring groove out and tap into position.
53. Install bearing support washer (Figure 5, Item 3) and new retaining ring (Figure 5, Item 2) on low speed shaft rear bearing (Figure 5, Item 4).
54. Install low shaft piston ring (Figure 5, Item 1) on low clutch shaft.

ASSEMBLY - CONTINUED

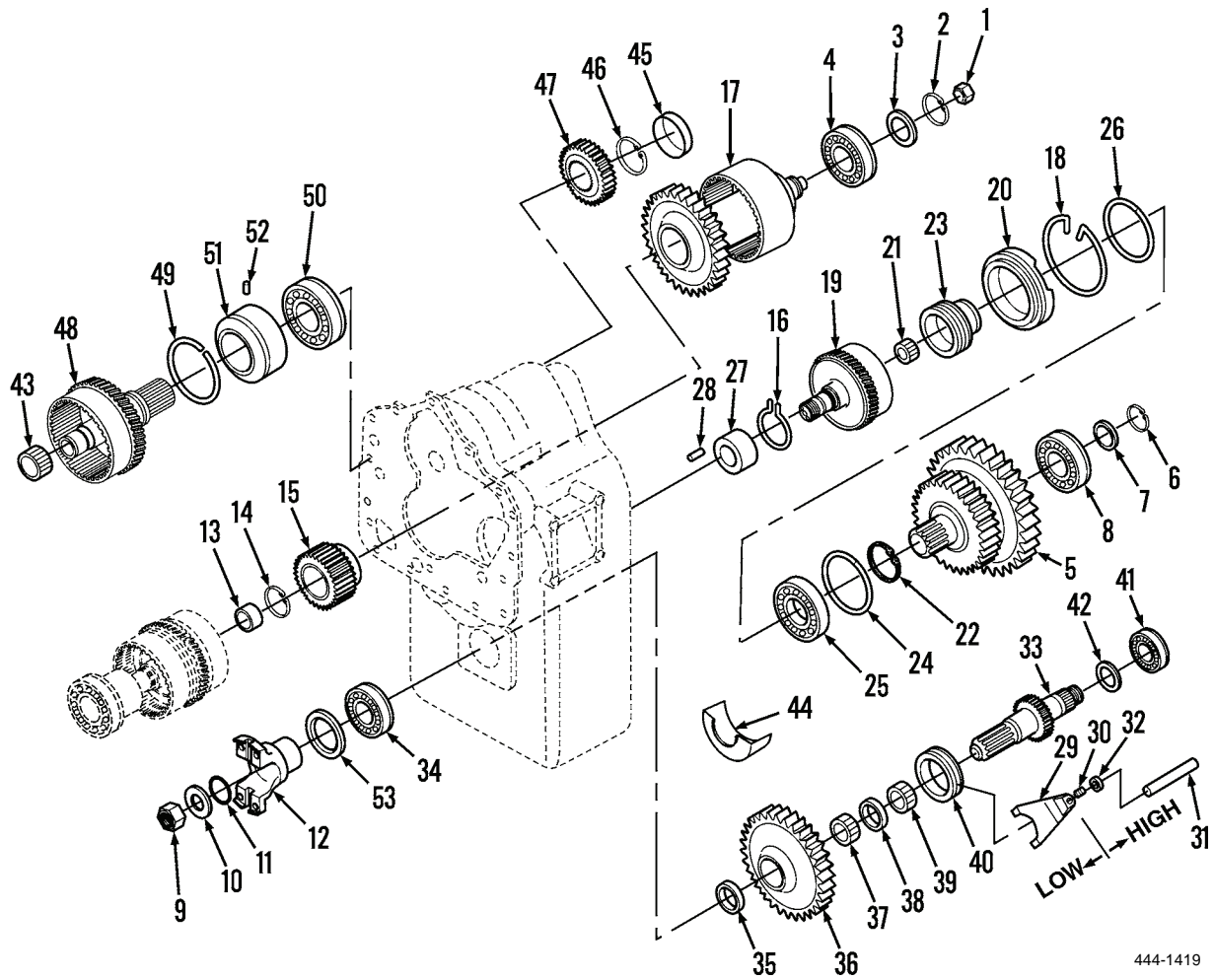

Figure 5. Transmission Gears and Clutches.

- 55. Install transmission rear cover (WP 0292).
- 56. Assemble torque converter group (WP 0290).

END OF TASK

END OF WORK PACKAGE



---

# GENERAL SUPPORT MAINTENANCE INSTRUCTIONS

## TRANSMISSION HOUSING REPAIR Disassembly, Cleaning, Inspection, Assembly

---

### INITIAL SETUP

#### Maintenance Level

General Support

#### Tools and Special Tools

Tool kit, general mechanic's (Item 15, WP 0309)  
Shop equipment, common no. 1 (Item 2, WP 0309)  
Expander tool (P/N CE805)

#### Materials/Parts

Cleaning compound, solvent (Item 10, WP 0310)  
Lubricating oil, OE/HDO-15/40 (Item 21, WP 0310)  
Rag, wiping (Item 26, WP 0310)  
Lockwasher (3)  
O-ring (7)  
Tube sleeve (5)

#### Equipment Condition

Gear and clutch group disassembled (WP 0293)

---

**DISASSEMBLY**

1. Remove three plugs (Figure 1, Items 1 and 2) from left side of transmission housing (Figure 1, Item 34).
2. Remove magnetic drain plug (Figure 1, Item 3) from rear of transmission housing (Figure 1, Item 34).
3. Remove two dowel pins (Figure 1, Item 4) from rear of transmission housing (Figure 1, Item 34).
4. Remove dipstick (Figure 1, Item 5) from right side of transmission housing (Figure 1, Item 34).
5. Remove two hose clamps (Figure 1, Item 6) from dipstick hose (Figure 1, Item 7) and remove dipstick hose.
6. Loosen nut on dipstick tube and remove dipstick tube (Figure 1, Item 8).
7. Remove connector (Figure 1, Item 9) from elbow (Figure 1, Item 10).
8. Remove elbow (Figure 1, Item 10) from transmission housing (Figure 1, Item 34).
9. Remove third speed pressure plug (Figure 1, Item 11) from transmission housing (Figure 1, Item 34).
10. Remove stud (Figure 1, Item 12) from transmission housing (Figure 1, Item 34).
11. Remove O-ring (Figure 1, Item 13) from transmission housing (Figure 1, Item 34) and discard.

**NOTE**

Disassembly of tubes is a repair function which may be necessary after inspection. Tubes and sleeves will not be removed unless inspection reveals a damaged or leaking part.

12. Remove two capscrews (Figure 1, Item 14) and lockwashers (Figure 1, Item 15) from suction tube assembly (Figure 1, Item 18). Discard lockwashers.
13. Remove capscrew (Figure 1, Item 16) and lockwasher (Figure 1, Item 17) from transmission housing (Figure 1, Item 34). Discard lockwasher.
14. Remove suction tube assembly (Figure 1, Item 18) from transmission housing (Figure 1, Item 34).
15. Remove O-ring (Figure 1, Item 19) and suction tube clip (Figure 1, Item 20) from transmission housing (Figure 1, Item 34). Discard O-ring.

**NOTE**

To drill out tube ends, use drill bit with same diameter of tubes at sleeves.

16. Drill out ends of low speed clutch pressure tube (Figure 1, Item 21) at points V and X and remove low speed clutch pressure tube from transmission housing (Figure 1, Item 34).
17. Remove two O-rings (Figure 1, Items 22 and 24) from transmission housing (Figure 1, Item 34) and discard.
18. Remove two tube sleeves (Figure 1, Items 23 and 25) from transmission housing (Figure 1, Item 34) and discard.
19. Drill out third speed tube (Figure 1, Item 26) ends at points U and W and remove third speed tube from transmission housing (Figure 1, Item 34).
20. Remove two O-rings (Figure 1, Items 27 and 29) from transmission housing (Figure 1, Item 34) and discard.
21. Remove two tube sleeves (Figure 1, Items 28 and 30) from transmission housing (Figure 1, Item 34) and discard.
22. Drill out lubrication clutch tube (Figure 1, Item 31) end at point Z and remove lubrication clutch tube from transmission housing (Figure 1, Item 34).
23. Remove O-ring (Figure 1, Item 32) and tube sleeve (Figure 1, Item 33) from transmission housing (Figure 1, Item 34). Discard O-ring and tube sleeve.

DISASSEMBLY - CONTINUED

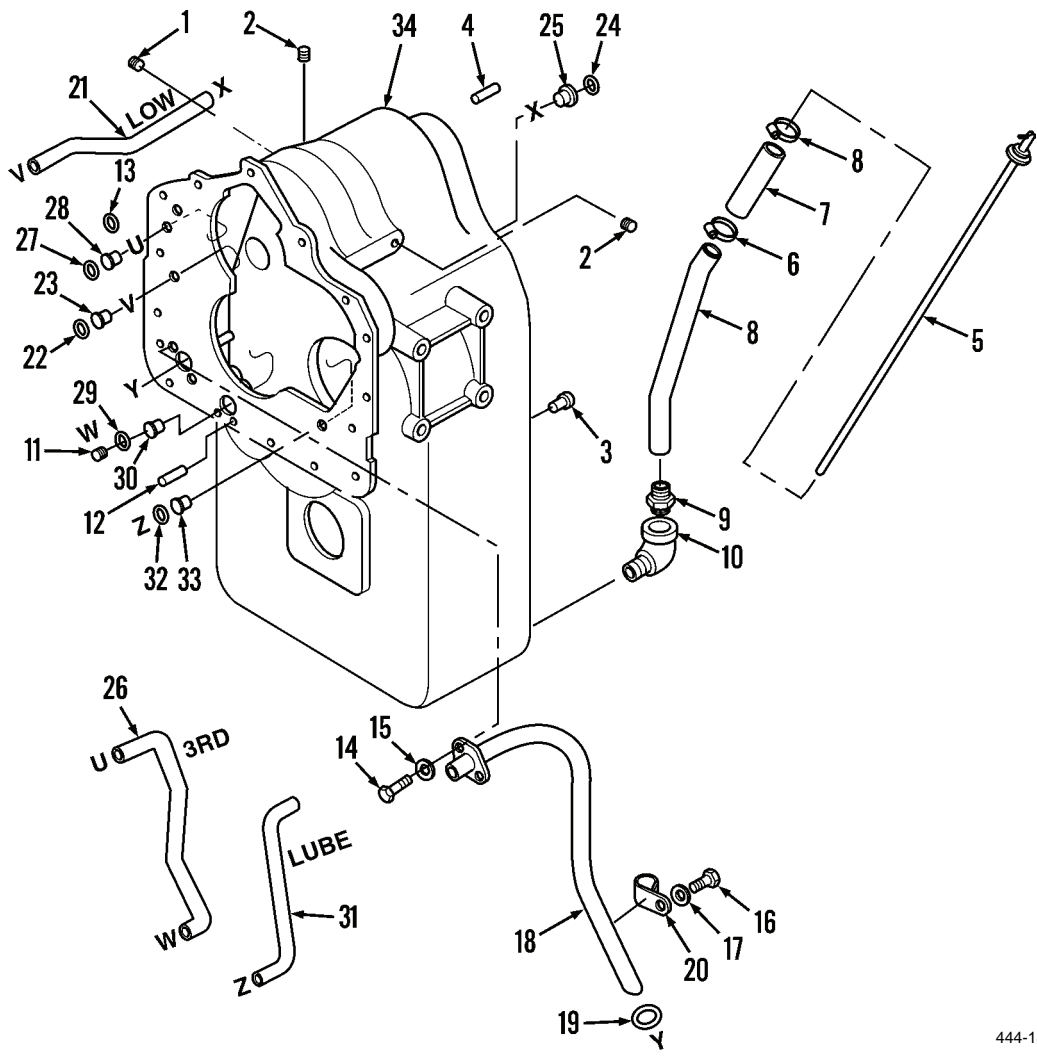

444-1444

Figure 1. Transmission Housing.

END OF TASK

**CLEANING****WARNING**

- Solvent cleaning compound MIL-PRF-680 Type III is an environmentally compliant and low toxic material. However, it may be irritating to the eyes and skin. Use protective gloves and goggles. Use in well-ventilated areas. Keep away from open flames and other sources of ignition. Failure to do so may result in injury or death to personnel.
  - Particles blown by compressed air are hazardous. DO NOT exceed 15 PSI (103 kPa) nozzle pressure when drying parts with compressed air. DO NOT direct compressed air against human skin. Make sure air stream is directed away from user and other personnel in the area. To prevent injury, user must wear protective goggles or face shield. Failure to follow this warning may result in injury to personnel.
1. Use solvent cleaning compound to clean transmission housing (Figure 2, Item 34). Thoroughly clean interior and exterior of housing. Dry thoroughly using moisture-free compressed air or clean rags.
  2. Use solvent cleaning compound to clean all other parts. Immerse parts in cleaning solvent and move slowly up and down until parts are thoroughly cleaned. Dry thoroughly using moisture-free compressed air or clean rags.

**END OF TASK****INSPECTION**

1. Inspect transmission housing (Figure 2, Item 34) tubes for cracks, damage, wear, or evidence of leaking condition. If any of these conditions are observed, remove and replace tubes. Inspect transmission housing for cracks, damage, wear, pits, nicks, and distortion. If any of these conditions are observed, replace transmission housing.
2. Inspect all other parts for cracks, pits, wear, distortion, and damaged condition. If any of these conditions are observed, replace part.

**END OF TASK**



**ASSEMBLY**

1. Position lubrication clutch tube (Figure 2, Item 31) on transmission housing (Figure 2, Item 34).
2. Position new tube sleeve (Figure 2, Item 33) over forward end of lubrication clutch tube (Figure 2, Item 31) and press firmly into bore of transmission housing (Figure 2, Item 34).

**NOTE**

Tube ends must remain flush with face of housing.

3. Install new tube sleeve (Figure 2, Item 33) in lubrication clutch tube (Figure 2, Item 31). Use an expander tool to install tube sleeves and tubes. Pull mandrel shaft out of tool as far as possible and insert expander in tube. Turn mandrel by hand until tool is firmly seated. Use a wrench to turn mandrel as far as possible. Back off mandrel and remove tool.
4. Lubricate new O-ring (Figure 2, Item 32) with clean engine oil and install on transmission housing (Figure 2, Item 34).
5. Position third speed tube (Figure 2, Item 26) on transmission housing (Figure 2, Item 34).
6. Position new tube sleeves (Figure 2, Items 28 and 30) over ends of third speed tube (Figure 2, Item 6) and press firmly into bore of transmission housing (Figure 2, Item 34).

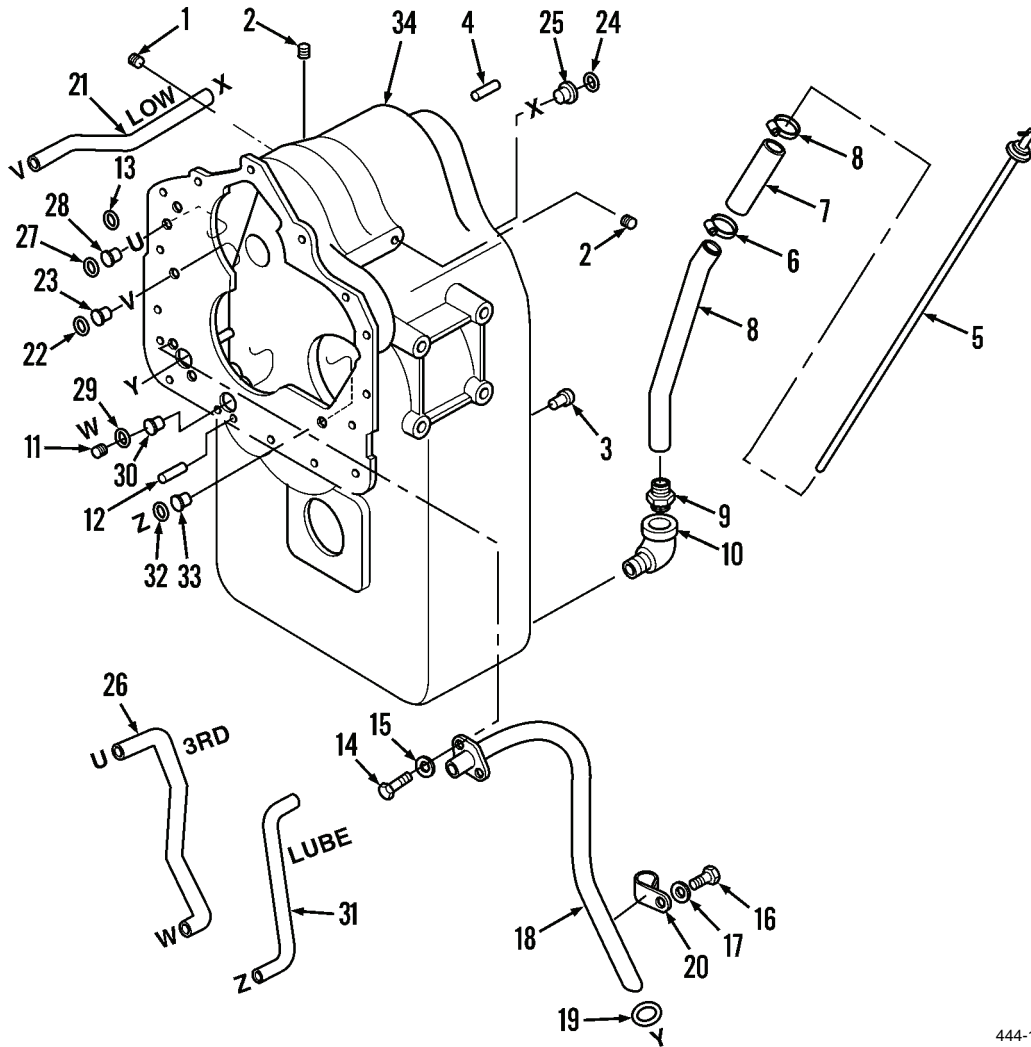

444-1444

**Figure 2. Transmission Housing.**

**ASSEMBLY - CONTINUED****NOTE**

Tube ends must remain flush with face of housing.

7. Use expander tool to install third speed tube (Figure 3, Item 26).
8. Lubricate new O-rings (Figure 3, Items 27 and 29) with clean engine oil and install on transmission housing (Figure 3, Item 34).
9. Position low speed clutch pressure tube (Figure 3, Item 21) on transmission housing (Figure 3, Item 34).
10. Position new tube sleeves (Figure 3, Items 23 and 25) over ends of low speed clutch pressure tube (Figure 3, Item 21) and press firmly into bore of housing.

**NOTE**

Tube ends must remain flush with face of housing.

11. Use expander tool to install low speed clutch pressure tube (Figure 3, Item 21) on transmission housing (Figure 3, Item 34).
12. Lubricate new O-rings (Figure 3, Items 22 and 24) with clean engine oil and install on transmission housing (Figure 3, Item 34).
13. Position suction tube clip (Figure 3, Item 20) on suction tube assembly (Figure 3, Item 18).
14. Lubricate new O-ring (Figure 3, Item 19) with clean engine oil and install on transmission housing (Figure 3, Item 34).
15. Position suction tube assembly (Figure 3, Item 18) on transmission housing (Figure 3, Item 34) and install three new lockwashers (Figure 3, Items 15 and 17) and capscrews (Figure 3, Items 14 and 16).



Solvent cleaning compound MIL-PRF-680 Type III is an environmentally compliant and low toxic material. However, it may be irritating to the eyes and skin. Use protective gloves and goggles. Use in well-ventilated areas. Keep away from open flames and other sources of ignition. Failure to do so may result in injury or death to personnel.

16. Use solvent cleaning compound to thoroughly clean transmission housing (Figure 3, Item 34) and tubes using clean, soft, absorbent, lintless rag moistened with solvent cleaning compound. Dry thoroughly with clean, soft, absorbent, lint-free rag.
17. Lubricate new O-ring (Figure 3, Item 13) with clean engine oil and install on transmission housing (Figure 3, Item 34).
18. Install stud (Figure 3, Item 12) on transmission housing (Figure 3, Item 34).
19. Install third speed pressure plug (Figure 3, Item 11) on transmission housing (Figure 3, Item 34).
20. Install elbow (Figure 3, Item 10) and connector (Figure 3, Item 9) on transmission housing (Figure 3, Item 34).
21. Install dipstick tube (Figure 3, Item 8) on connector (Figure 3, Item 9).
22. Position dipstick hose (Figure 3, Item 7) on dipstick tube (Figure 3, Item 8).
23. Install two hose clamps (Figure 3, Item 6) on dipstick hose (Figure 3, Item 7) and tighten.
24. Install dipstick (Figure 3, Item 5) in dipstick hose (Figure 3, Item 7) and dipstick tube (Figure 3, Item 8).
25. Install two dowel pins (Figure 3, Item 4) on transmission housing (Figure 3, Item 34).

**ASSEMBLY - CONTINUED**

26. Install magnetic drain plug (Figure 3, Item 3) on transmission housing (Figure 3, Item 34).
27. Install two plugs (Figure 3, Item 2) on transmission housing (Figure 3, Item 34).
28. Install plug (Figure 3, Item 1) on transmission housing (Figure 3, Item 34).

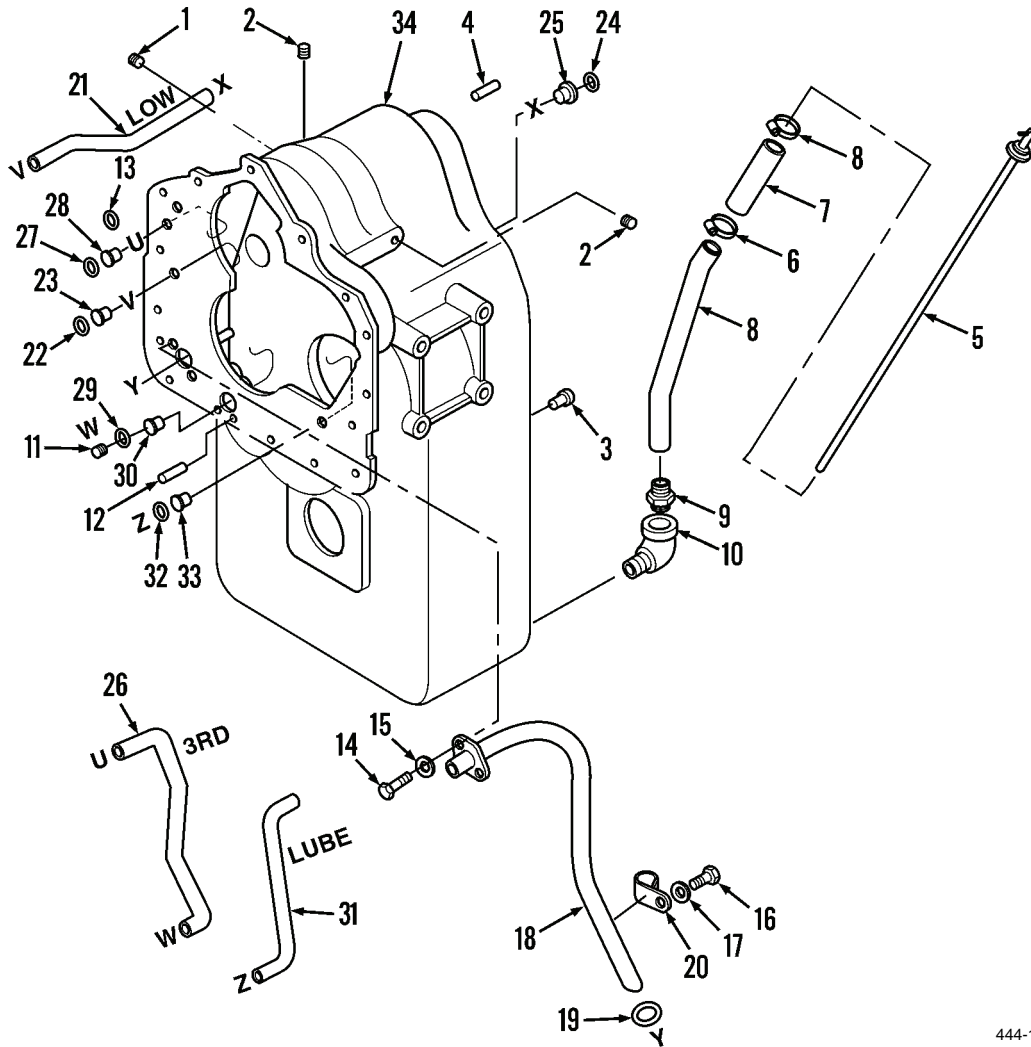

444-1444

**Figure 3. Transmission Housing.**

**END OF TASK**

**END OF WORK PACKAGE**



---

# GENERAL SUPPORT MAINTENANCE INSTRUCTIONS

## REVERSE AND SECOND CLUTCH REPAIR

Disassembly, Cleaning, Inspection, Assembly

---

### INITIAL SETUP

#### Maintenance Level

General Support

#### Tools and Special Tools

Tool kit, general mechanic's (Item 15, WP 0309)  
Shop equipment, common no. 1 (Item 2, WP 0309)  
Arbor press, 1/2-ton capacity  
Rod, 6 in. long x 3/8-in. diameter.  
Sleeve, 6 in. long x 2-3/4-in. ID  
Sleeve, 6 in. long, 3-1/4-in. OD, 2-3/4 in. ID with a  
1-1/2 in. x 1 in. opening

#### Materials/Parts

Cleaning compound, solvent (Item 10, WP 0310)  
Lubricating oil, OE/HDO-15/40 (Item 21, WP  
0310)  
Rag, wiping (Item 26, WP 0310)  
Piston ring  
Piston seals

#### Equipment Condition

Reverse and second clutch assembly removed from  
transmission (WP 0293)

---

**DISASSEMBLY**

1. At reverse side of clutch assembly, remove three reverse and second shaft piston rings (Figure 1, Item 1).
2. Remove retaining rings (Figure 1, Items 2 and 3).
3. Remove reverse and second shaft bearing (Figure 1, Item 4). Use puller.
4. Remove reverse clutch gear and hub assembly (Figure 1, Item 5). Pry reverse clutch gear and hub assembly from clutch assembly using pry bars. Pry far enough to install gear puller, then remove gear and hub assembly with puller.
5. Remove retaining ring (Figure 1, Item 6) and bearing spacer (Figure 1, Item 7).
6. Remove clutch gear bearing (Figure 1, Item 8). Use puller.
7. Remove retaining ring (Figure 1, Item 9).
8. Remove clutch driven gear bearing (Figure 1, Item 10). Use puller.
9. Remove retaining ring (Figure 1, Item 11). Use a screwdriver and remove carefully.
10. Remove clutch disc backing plate (Figure 1, Item 12).
11. Remove eight inner clutch discs (Figure 1, Item 13) and eight outer clutch discs (Figure 1, Item 14).
12. Compress piston return spring spacer (Figure 1, Item 15). Use sleeve (with portion removed) installed in press, to remove retaining ring (Figure 1, Item 16), piston return spring spacer, and piston return springs (Figure 1, Item 17).
13. Remove retaining ring (Figure 1, Item 16) through opening in sleeve.
14. Carefully and slowly release pressure on sleeve. Release and remove piston return spring spacer (Figure 1, Item 15).
15. Remove five piston return springs (Figure 1, Item 17).
16. Invert reverse and second shaft drum and plug assembly (Figure 1, Item 18).
17. Remove clutch piston (Figure 1, Item 19). Tap reverse and second shaft drum and plug assembly (Figure 1, Item 18) on block of wood to remove.
18. Remove outer clutch piston seal (Figure 1, Item 20) and inner clutch piston seal (Figure 1, Item 21). Discard seals.
19. At second clutch side, remove retaining ring (Figure 1, Item 22) and clutch disc backing plate (Figure 1, Item 23).
20. Remove six inner clutch discs (Figure 1, Item 24) and six outer clutch discs (Figure 1, Item 25).
21. Compress spring retainer (Figure 1, Item 26). Use sleeve (with portion removed) installed in press to remove spring retainer, retaining ring (Figure 1, Item 27), and piston spring (Figure 1, Item 28).
22. Remove retaining ring (Figure 1, Item 27) through opening in sleeve.
23. Carefully and slowly release pressure on sleeve. Release and remove spring retainer (Figure 1, Item 26).
24. Remove piston spring (Figure 1, Item 28).
25. Invert reverse and second shaft drum and plug assembly (Figure 1, Item 18).
26. Remove clutch piston (Figure 1, Item 29). Tap reverse and second shaft drum and plug assembly (Figure 1, Item 18) on block of wood to remove clutch piston.
27. Remove outer clutch piston seal (Figure 1, Item 30) and inner clutch piston seal (Figure 1, Item 31). Discard seals.

DISASSEMBLY - CONTINUED

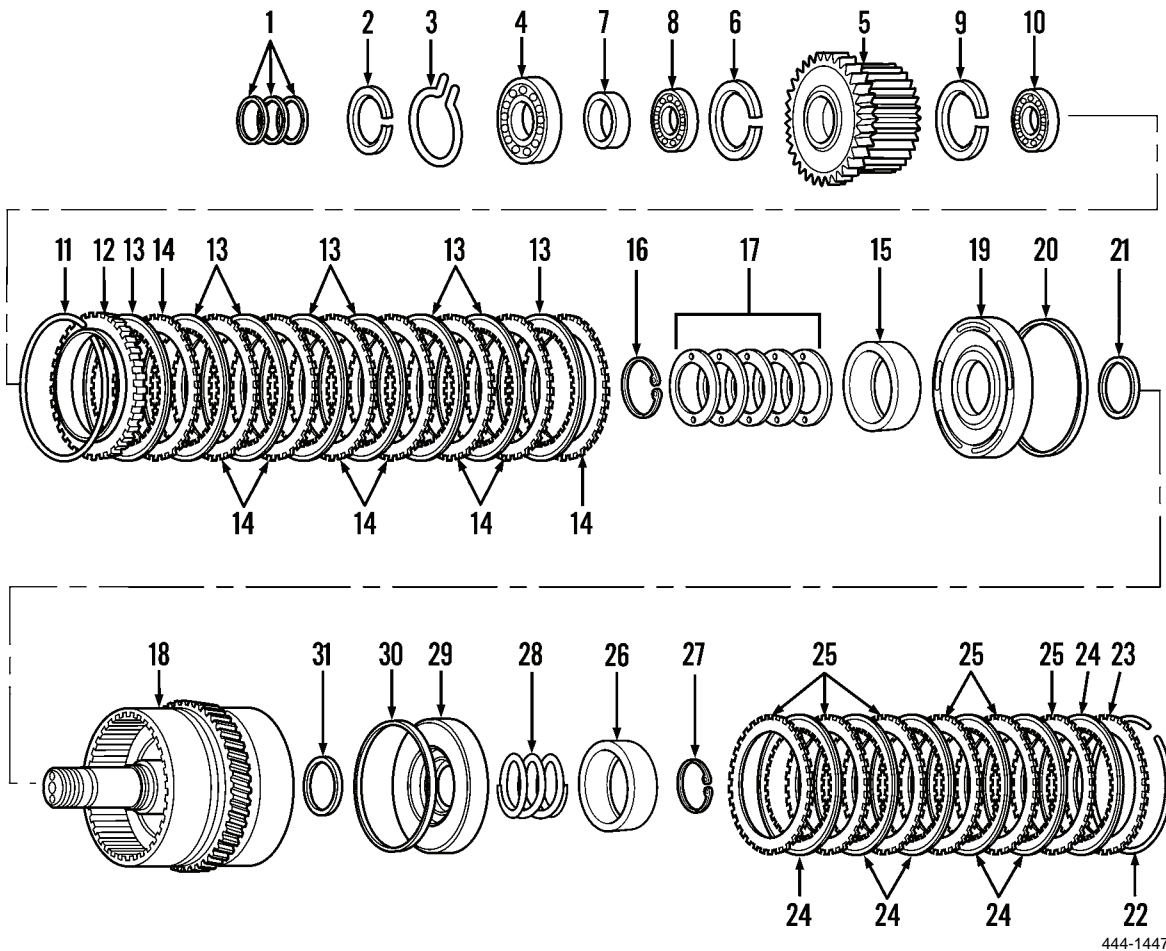

444-1447

Figure 1. Reverse and Second Clutch.

END OF TASK

**CLEANING****WARNING**

- Solvent cleaning compound MIL-PRF-680 Type III is an environmentally compliant and low toxic material. However, it may be irritating to the eyes and skin. Use protective gloves and goggles. Use in well-ventilated areas. Keep away from open flames and other sources of ignition. Failure to do so may result in injury or death to personnel.
  - Particles blown by compressed air are hazardous. DO NOT exceed 15 PSI (103 kPa) nozzle pressure when drying parts with compressed air. DO NOT direct compressed air against human skin. Make sure air stream is directed away from user and other personnel in the area. To prevent injury, user must wear protective goggles or face shield. Failure to follow this warning may result in injury to personnel.
1. Clean bearings with solvent cleaning compound. Immerse bearings in cleaning solvent and move slowly up and down. Repeat until bearings are thoroughly clean. Dry bearings with compressed air. Direct air stream across bearing. Do not spin bearings when drying. Rotate bearings slowly by hand to facilitate drying.
  2. Clean all other parts with solvent cleaning compound. Dry parts with compressed air or clean rags.

**END OF TASK**



**INSPECTION**

1. Inspect reverse and second shaft drum and plug assembly. Inspect teeth for wear, pits, cracks, nicks, and scores. Inspect shaft and quills to make certain they are not sprung, bent, or have twisted splines, and that shafts are true. Inspect overall for wear, cracks, distortion, and damage. If any of these conditions are observed, replace reverse and second shaft drum and plug assembly.
2. Inspect inner clutch discs and outer clutch discs for wear, cracks, damage, and breaks. If any of these conditions are observed, replace disc.
3. Inspect piston return springs and piston spring for cracks, distortion, broken condition, wear, and evidence of permanent set. If any of these conditions are observed, replace spring.
4. Inspect bearings for wear, chips, nicks, and damage. If any of these conditions are observed, replace bearing. Dip bearings in clean, light lubricating oil and wrap in clean lint-free rag or paper.
5. Inspect all other parts for wear, damage, cracks, and distortion. If any of these conditions are observed, replace part.

**END OF TASK**

**ASSEMBLY**

1. Install new outer clutch piston seal (Figure 2, Item 30) on clutch piston (Figure 2, Item 29). Lubricate oil seal with lubricating oil. To size seal, rotate clutch piston while holding a round object against new seal as shown. Rotate clutch piston until seal is flush with outer diameter of clutch piston.
2. Install new inner clutch piston seal (Figure 2, Item 31) on clutch piston (Figure 2, Item 31). Lubricate oil seal with lubricating oil. To size seal, rotate clutch piston while holding a round object against new seal as shown. Rotate clutch piston until seal is flush with outer diameter of clutch piston.

**CAUTION**

Take care not to damage inner and outer seals.

**NOTE**

Seals must be sized before installing clutch piston in drum and plug assembly.

3. At second clutch side, install clutch piston (Figure 2, Item 29) into reverse and second shaft drum and plug assembly (Figure 2, Item 18).
4. Install piston spring (Figure 2, Item 28) and spring retainer (Figure 2, Item 26).
5. Position retaining ring (Figure 2, Item 27).
6. Using sleeve installed in press, compress spring retainer (Figure 2, Item 26) and piston spring (Figure 2, Item 28).
7. Install retaining ring (Figure 2, Item 27) through opening in sleeve. Remove sleeve.
8. Apply light film of lubricating oil to one outer clutch disc (Figure 2, Item 25) and install disc.
9. Apply light film of lubricating oil to one inner clutch disc (Figure 2, Item 24) and install disc.
10. Apply light film of lubricating oil to remaining outer clutch discs (Figure 2, Item 25) and inner clutch discs (Figure 2, Item 24). Position an outer disc next to an inner disc until all discs are installed (last disc will be an inner disc).
11. Install clutch backing plate (Figure 2, Item 23) and retaining ring (Figure 2, Item 22).
12. At clutch piston (Figure 2, Item 19), size outer clutch piston seal (Figure 2, Item 20) as described in step 1.
13. At clutch piston (Figure 2, Item 19), size inner clutch piston seal (Figure 2, Item 21) as described in step 2.

**CAUTION**

Take care not to damage inner and outer seals.

**NOTE**

Seals must be sized before installing clutch piston in drum and plug assembly.

14. At reverse clutch side, install clutch piston (Figure 2, Item 19) into reverse and second shaft drum and plug assembly (Figure 2, Item 18).
15. Position piston return spring spacer (Figure 2, Item 15).
16. Install five piston return springs (Figure 2, Item 17). Position first piston return spring with curved side up, then alternate remaining piston return springs.
17. Position retaining ring (Figure 2, Item 16) on drum and plug assembly (Figure 2, Item 18).
18. Using sleeve installed in press, compress piston return spring spacer (Figure 2, Item 15).
19. Install retaining ring (Figure 2, Item 16) through opening in sleeve. Remove sleeve.
20. Install one outer clutch disc (Figure 2, Item 14).
21. Install one inner clutch disc (Figure 2, Item 13).

ASSEMBLY - CONTINUED

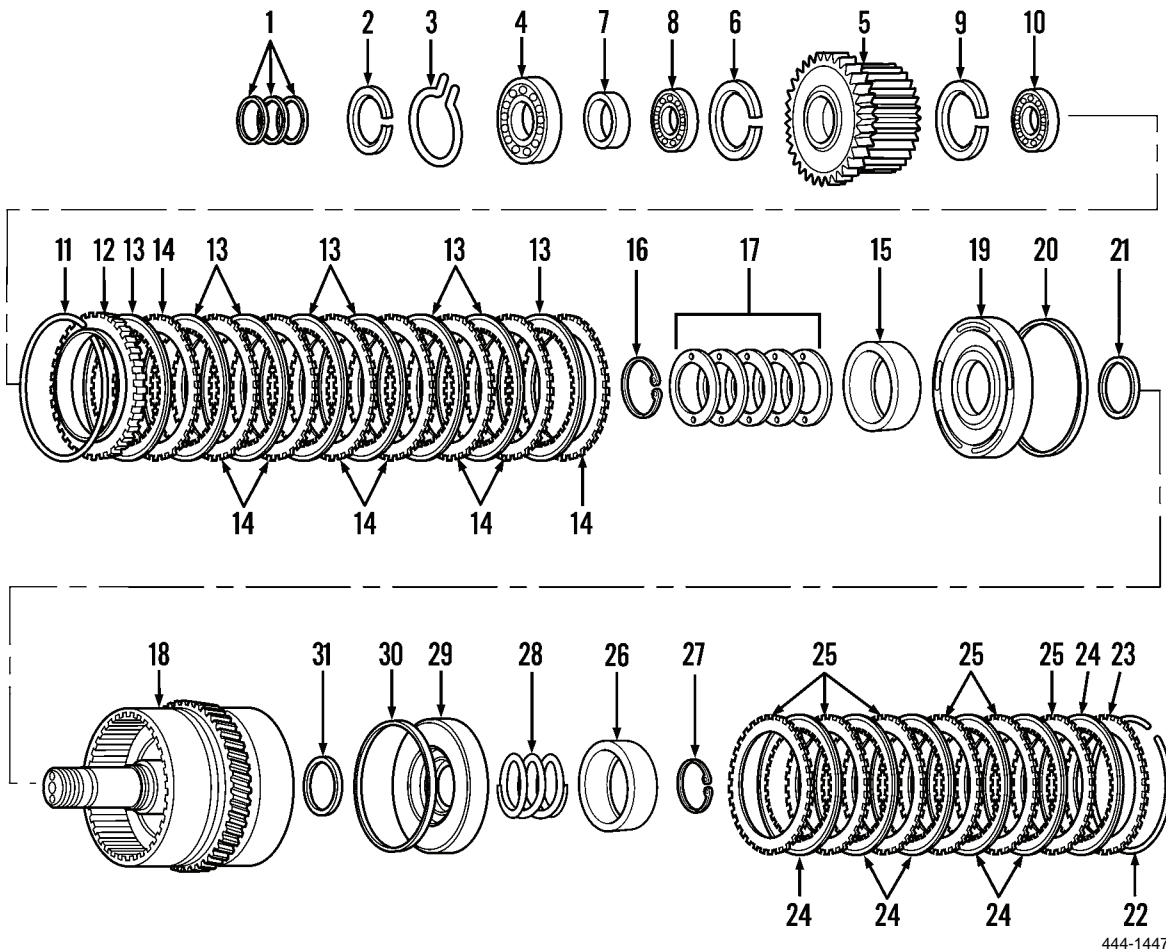

444-1447

Figure 2. Reverse and Second Clutch.

---

**ASSEMBLY - CONTINUED**

22. Install remaining outer clutch discs (Figure 3, Item 14) and inner clutch discs (Figure 3, Item 13). Position an outer disc next to an inner disc until all discs are installed (last disc will be an inner disc).
23. Install clutch disc backing plate (Figure 3, Item 12) and retaining ring (Figure 3, Item 11).
24. Install clutch driven gear bearing (Figure 3, Item 10). Use mallet and sleeve.
25. Install retaining ring (Figure 3, Item 9).
26. Install bearing spacer (Figure 3, Item 7) and retaining ring (Figure 3, Item 6).

**CAUTION**

Do not force this procedure.

27. Install reverse clutch gear and hub assembly (Figure 3, Item 5). Align splines on hub with internal teeth of discs. Tap hub gently into position. Hub splines must be fully meshed with internal teeth of all discs.
28. Install clutch gear bearing (Figure 3, Item 8). Use mallet and sleeve.

**NOTE**

Install reverse and second shaft bearing with retaining ring groove at top.

29. Install reverse and second shaft bearing (Figure 3, Item 4). Use mallet and sleeve.
30. Install retaining ring (Figure 3, Item 3) into reverse and second shaft bearing (Figure 3, Item 4) groove.
31. Install retaining ring (Figure 3, Item 2).
32. Install three reverse and second shaft piston rings (Figure 3, Item 1).

ASSEMBLY - CONTINUED

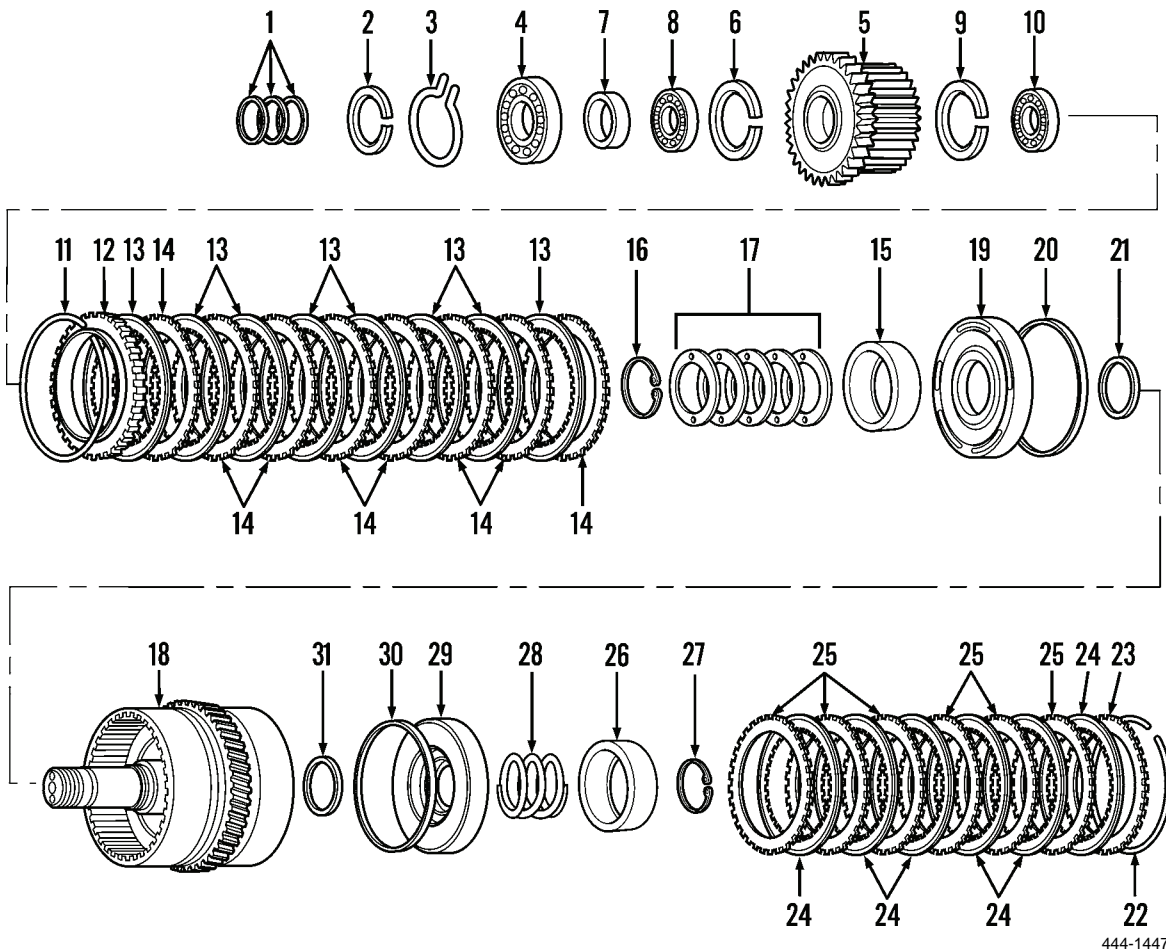

444-1447

Figure 3. Reverse and Second Clutch.

END OF TASK

END OF WORK PACKAGE



---

# GENERAL SUPPORT MAINTENANCE INSTRUCTIONS

## LOW CLUTCH REPAIR

### Disassembly, Cleaning, Inspection, Assembly

---

#### INITIAL SETUP

##### Maintenance Level

General Support

##### Tools and Special Tools

Tool kit, general mechanic's (Item 15, WP 0309)  
Shop equipment, common no. 1 (Item 2, WP 0309)  
Arbor press, 1/2-ton capacity  
Rod, 6 in. long x 3/8-in. diameter  
Sleeve, 6 in. long x 2-3/4 in. ID  
Sleeve, 6 in. long, 3-1/4 in. OD, 2-3/4 in. ID with a  
1-1/2 in. x 1 in. opening

##### Materials/Parts

Cleaning compound, solvent (Item 10, WP 0310)  
Lubricating oil, OE/HDO-15/40 (Item 21, WP  
0310)  
Rag, wiping (Item 26, WP 0310)  
Locating ring (2)  
Piston seal (2)  
Retaining ring (2)

##### Equipment Condition

Low clutch assembly removed from transmission  
(WP 0293)

---

**DISASSEMBLY**

1. At low clutch assembly, remove front bearing (Figure 1, Item 2). Use puller.
2. Remove spacer (Figure 1, Item 3).
3. Remove low shaft gear and hub assembly (Figure 1, Item 1). Use puller.
4. Remove low speed gear bearing (Figure 1, Item 4) from gear and hub assembly (Figure 1, Item 1). Use puller or press.
5. Remove low speed gear spacer (Figure 1, Item 5).
6. Remove bearing locating rings (Figure 1, Items 6 and 7) and discard.
7. Remove low speed gear bearing (Figure 1, Item 8).
8. Remove low speed bearing retaining ring (Figure 1, Item 9) and discard.
9. Remove retaining ring (Figure 1, Item 10) and discard.
10. Remove clutch disc backing plate (Figure 1, Item 11).
11. Remove eight inner clutch discs (Figure 1, Item 12) and eight outer clutch discs (Figure 1, Item 13). Turn low clutch shaft drum and bleed valve assembly (Figure 1, Item 20) over to remove.
12. Remove retaining ring (Figure 1, Item 14). Install sleeve in press. Place low clutch assembly on press and compress spring retainer (Figure 1, Item 15). Remove retaining ring through opening in sleeve. Carefully and slowly release pressure on spring retainer.
13. Remove spring retainer (Figure 1, Item 15) from low clutch assembly.
14. Remove piston return spring (Figure 1, Item 16) from clutch piston (Figure 1, Item 17).
15. Remove clutch piston (Figure 1, Item 17) from low clutch shaft drum and bleed valve assembly (Figure 1, Item 20). Turn low clutch shaft drum and bleed valve assembly over and tap on block of wood to remove.
16. Remove outer clutch piston seal (Figure 1, Item 18) from clutch piston (Figure 1, Item 17) and discard.
17. Remove inner clutch piston seal (Figure 1, Item 19) from low clutch shaft drum and bleed valve assembly (Figure 1, Item 20) and discard.

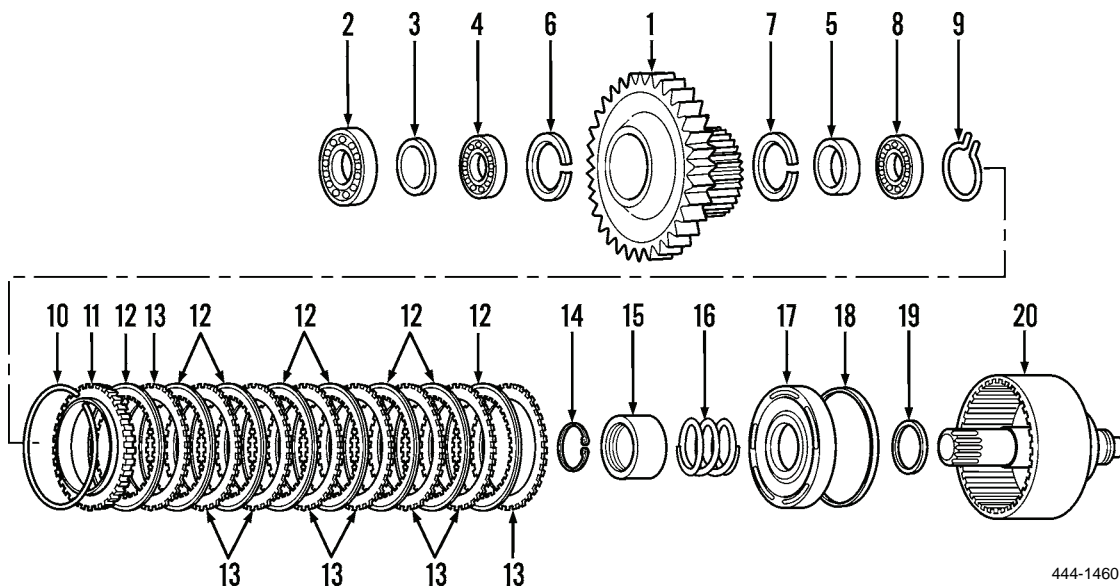

444-1460

**Figure 1. Low Clutch.****END OF TASK**



**CLEANING****WARNING**

- Solvent cleaning compound MIL-PRF-680 Type III is an environmentally compliant and low toxic material. However, it may be irritating to the eyes and skin. Use protective gloves and goggles. Use in well-ventilated areas. Keep away from open flames and other sources of ignition. Failure to do so may result in injury or death to personnel.
  - Particles blown by compressed air are hazardous. DO NOT exceed 15 PSI (103 kPa) nozzle pressure when drying parts with compressed air. DO NOT direct compressed air against human skin. Make sure air stream is directed away from user and other personnel in the area. To prevent injury, user must wear protective goggles or face shield. Failure to follow this warning may result in injury to personnel.
1. Use solvent cleaning compound to clean bearings (Figure 1, Items 2, 4, and 8). Immerse bearings in cleaning solvent and move slowly up and down. Remove bearings. Strike larger side of cone against block of wood to dislodge solidified particles of lubricant. Immerse again in solvent cleaning compound. Repeat this process until bearings are thoroughly clean. Dry bearings with moisture-free compressed air. Direct air stream across bearing. Do not spin the bearings when drying. Rotate bearings slowly by hand to facilitate drying.
  2. Use solvent cleaning compound to clean all parts. Immerse parts in solvent cleaning compound and move slowly up and down until parts are thoroughly cleaned. Dry parts thoroughly using compressed air or clean cloths.

**END OF TASK****INSPECTION**

1. Inspect low clutch shaft drum and bleed valve assembly (Figure 1, Item 20). Inspect teeth for wear, pits, cracks, chips, nicks, and scores. Inspect body for cracks, wear, distortion, and damage. If any of these conditions are observed, replace low clutch drum and bleed valve assembly.
2. Inspect inner clutch discs (Figure 1, Item 12) and outer clutch discs (Figure 1, Item 13). Replace disc if worn, cracked, damaged, or broken.
3. Inspect piston return spring (Figure 1, Item 16). Replace if cracked, worn, distorted, broken, or permanently set.
4. Inspect bearings (Figure 1, Items 2, 4, and 8). Inspect rollers and cages for wear, chips, nicks, and damage. Replace if any of these conditions are observed. Dip bearings in clean, light lubricating oil and wrap in clean lint-free rag or paper.
5. Inspect all other parts. Inspect for wear, damage, cracks, and distortion. If any of these conditions are observed, replace part.

**END OF TASK**

## ASSEMBLY

1. Use clean engine oil to lubricate new outer clutch piston seal (Figure 2, Item 18). Install and size seal. To size seal, rotate clutch piston while holding a round object against new seal. Rotate clutch piston until seal is flush with outer diameter of clutch piston.
2. Use clean engine oil to lubricate new inner clutch piston seal (Figure 2, Item 19). Install seal and size. To size seal, rotate clutch piston while holding a round object against new seal. Rotate clutch piston until seal is flush with outer diameter of clutch piston.

## CAUTION

Do not damage inner or outer seals.

## NOTE

Seals must be sized before installing clutch piston in low clutch shaft drum and bleed valve assembly.

3. Install clutch piston (Figure 2, Item 17) on low clutch shaft drum and bleed valve assembly (Figure 2, Item 20).
4. Position piston return spring (Figure 2, Item 16) on clutch piston (Figure 2, Item 17).
5. Position spring retainer (Figure 2, Item 15) on piston return spring (Figure 2, Item 16).
6. Position retaining ring (Figure 2, Item 14) on spring retainer (Figure 2, Item 15). Install sleeve in press; place low clutch assembly on press and compress spring retainer. Install retaining ring through opening in sleeve. Remove low clutch assembly and sleeve from press.
7. Install low speed bearing retaining ring (Figure 2, Item 9) on low clutch assembly.
8. Install outer clutch disc (steel) (Figure 2, Item 13). Install one disc, after applying light film of lubricating oil.
9. Install inner clutch disc (friction) (Figure 2, Item 12). Install one disc, after applying light film of lubricating oil.
10. Install outer clutch discs (Figure 2, Item 13) and inner clutch discs (Figure 2, Item 12). Coat each disc lightly with lubricating oil. Position outer (steel) disc next to an inner (friction) disc until all discs are installed (last disc installed is an inner disc). Align teeth of all discs.
11. Install clutch disc backing plate (Figure 2, Item 11) on low clutch assembly.
12. Install new retaining ring (Figure 2, Item 10) on low clutch assembly.
13. Install new low speed bearing retaining ring (Figure 2, Item 9) on low clutch assembly.
14. Install low speed gear bearing (Figure 2, Item 8) on low clutch assembly.
15. Install new bearing locating ring (Figure 2, Item 7) on low speed gear bearing (Figure 2, Item 8).
16. Install low speed gear spacer (Figure 2, Item 5) on low clutch assembly.
17. Install low shaft gear and hub assembly (Figure 2, Item 1) on low clutch assembly. Align splines on clutch hub with internal teeth of friction discs. Do not force installation. Gear splines must mesh with internal teeth of all friction discs.
18. Install new bearing locating ring (Figure 2, Item 6) on low shaft gear and hub assembly (Figure 2, Item 1).
19. Install low speed gear bearing (Figure 2, Item 4) on low shaft gear and hub assembly (Figure 2, Item 1).
20. Install spacer (Figure 2, Item 3) on low shaft gear and hub assembly (Figure 2, Item 1).
21. Install front bearing (Figure 2, Item 2) on low shaft gear and hub assembly (Figure 2, Item 1).

ASSEMBLY - CONTINUED

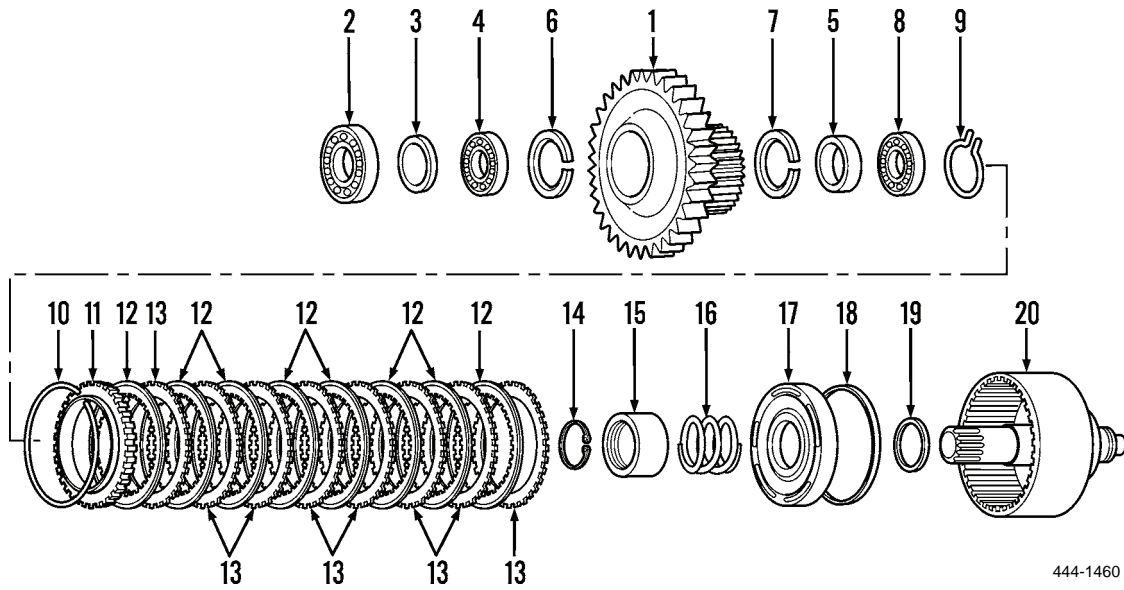

444-1460

Figure 2. Low Clutch.

END OF TASK

END OF WORK PACKAGE



---

# GENERAL SUPPORT MAINTENANCE INSTRUCTIONS

## THIRD CLUTCH REPAIR Disassembly, Cleaning, Inspection, Assembly

---

### INITIAL SETUP

#### Maintenance Level

General Support

#### Tools and Special Tools

Tool kit, general mechanic's (Item 15, WP 0309)  
Shop equipment, common no. 1 (Item 2, WP 0309)  
Arbor press, 1/2-ton capacity  
Rod, 6 in. long x 3/8-in. diameter  
Sleeve, 6 in. long x 2-3/4 in. ID  
Sleeve, 6 in. long, 3-1/4 in. OD, 2-3/4 in. ID with a  
1-1/2 in. x 1 in. opening

#### Materials/Parts

Cleaning compound, solvent (Item 10, WP 0310)  
Lubricating oil, OE/HDO-15/40 (Item 21, WP  
0310)  
Rag, wiping (Item 26, WP 0310)  
Locating ring  
Piston ring (2)  
Piston seal (2)  
Retaining ring (3)

#### Equipment Condition

Third clutch assembly removed from transmission  
(WP 0293)

---

**DISASSEMBLY**

1. Remove two third clutch shaft piston rings (Figure 1, Item 1) from third clutch assembly and discard.
2. Remove retaining ring (Figure 1, Item 2) from third clutch assembly and discard.
3. Remove third clutch shaft front bearing locating ring (Figure 1, Item 3) from third clutch assembly and discard.
4. Use puller to remove third clutch shaft front bearing (Figure 1, Item 4) from third clutch assembly.
5. Remove retaining ring (Figure 1, Item 5) from third clutch assembly and discard.
6. Remove clutch disc backing plate (Figure 1, Item 6) from third clutch assembly.
7. Remove six inner clutch discs (Figure 1, Item 7) from third clutch assembly.
8. Remove six outer clutch discs (Figure 1, Item 8) from third clutch assembly.
9. Compress spring retainer (Figure 1, Item 9). Use sleeve (with opening) installed in press for removing retaining ring (Figure 1, Item 10), spring retainer, and piston return spring (Figure 1, Item 11).
10. Remove retaining ring (Figure 1, Item 10) through opening in sleeve, carefully and slowly release pressure on spring, then remove sleeve. Discard retaining ring.
11. Remove spring retainer (Figure 1, Item 9) from clutch piston (Figure 1, Item 12).
12. Remove piston return spring (Figure 1, Item 11) from clutch piston (Figure 1, Item 12).
13. Invert third clutch shaft drum and plug assembly (Figure 1, Item 15) from third clutch assembly.
14. Remove clutch piston (Figure 1, Item 12) from third clutch assembly. Tap third clutch shaft drum and plug assembly (Figure 1, Item 15) on block of wood to remove.
15. Remove outer clutch piston seal (Figure 1, Item 13) from clutch piston (Figure 1, Item 12) and discard.
16. Remove inner clutch piston seal (Figure 1, Item 14) from third clutch assembly and discard.

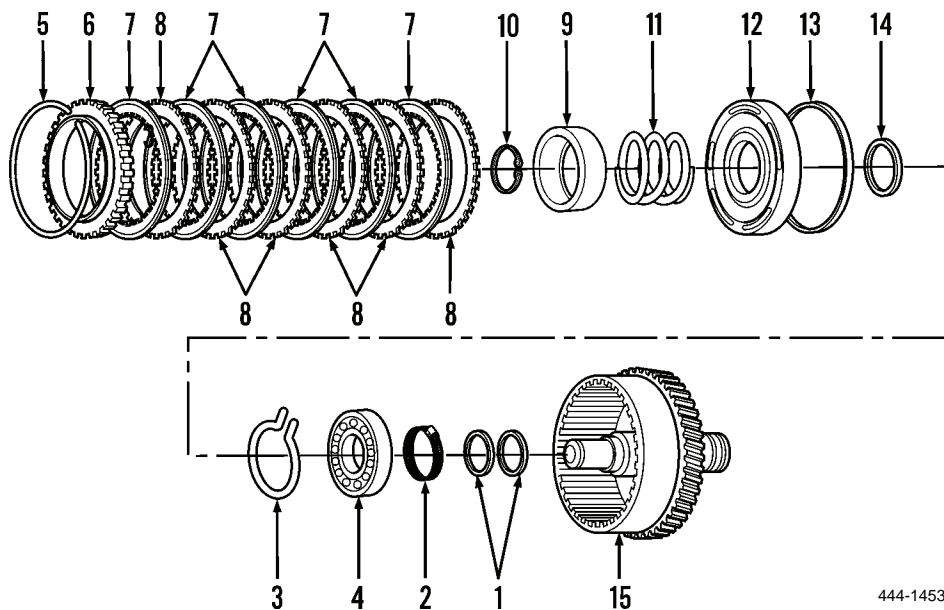

444-1453

**Figure 1. Third Clutch.****END OF TASK**

**CLEANING****WARNING**

- Solvent cleaning compound MIL-PRF-680 Type III is an environmentally compliant and low toxic material. However, it may be irritating to the eyes and skin. Use protective gloves and goggles. Use in well-ventilated areas. Keep away from open flames and other sources of ignition. Failure to do so may result in injury or death to personnel.
  - Particles blown by compressed air are hazardous. DO NOT exceed 15 PSI (103 kPa) nozzle pressure when drying parts with compressed air. DO NOT direct compressed air against human skin. Make sure air stream is directed away from user and other personnel in the area. To prevent injury, user must wear protective goggles or face shield. Failure to follow this warning may result in injury to personnel.
1. Clean third clutch shaft front bearing (Figure 1, Item 4). Immerse bearing in solvent cleaning compound and move slowly up and down. Remove bearing. Strike larger side of cone against block of wood to dislodge solidified particles of lubricant. Immerse again in solvent cleaning compound. Repeat this process until bearing is thoroughly clean. Dry with moisture-free compressed air. Direct air stream across bearing. Do not spin bearing when drying. Rotate bearing slowly by hand to facilitate drying.
  2. Use solvent cleaning compound to clean all other parts. Immerse parts in cleaning solvent and move slowly up and down until parts are thoroughly cleaned. Dry parts thoroughly using compressed air or clean rags.

**END OF TASK****INSPECTION**

1. Inspect third clutch shaft drum and plug assembly (Figure 1, Item 15) teeth for wear, pits, cracks, nicks, and scores. Inspect shaft and quills to make certain they are not sprung, bent, or have twisted splines, and that shafts are true. Inspect overall for wear, cracks, distortion, and damage. If any of these conditions are observed, replace part.
2. Inspect inner clutch discs (Figure 1, Item 7) and outer clutch discs (Figure 1, Item 8). Replace disc if worn, cracked, damaged, or broken.
3. Inspect piston return spring (Figure 1, Item 11). Replace if cracked, worn, distorted, broken, or permanently set.
4. Inspect third clutch shaft bearing (Figure 1, Item 4) rollers and cages for wear, chips, nicks, and damage. If any of these conditions are observed, replace bearing. Dip bearing in clean light lubricating oil and wrap in clean lint-free rag or paper.
5. Inspect all other parts. Inspect for damage, wear, cracks, and distortion. If any of these conditions are observed, replace part.

**END OF TASK**

---

**ASSEMBLY**

1. Use clean lubricating oil to lubricate new outer clutch piston seal (Figure 1, Item 13) then install on clutch piston (Figure 1, Item 12). To size seal, rotate clutch piston while holding a round object against new seal. Rotate clutch piston until seal is flush with outer diameter of clutch piston.
2. Use clean lubricating oil to lubricate new inner clutch piston seal (Figure 1, Item 14). Install inner clutch piston seal and size. To size seal, rotate clutch piston while holding a round object against new seal. Rotate clutch piston until seal is flush with outer diameter of clutch piston.

**CAUTION**

Take care not to damage inner and outer seals.

**NOTE**

Seals must be sized before installing clutch piston into drum and plug assembly.

3. Install clutch piston (Figure 2, Item 12) on third clutch assembly.
4. Position piston return spring (Figure 2, Item 11) on clutch piston (Figure 2, Item 12).
5. Position spring retainer (Figure 2, Item 9) on piston return spring (Figure 2, Item 11).
6. Position new retaining ring (Figure 2, Item 10) on third clutch assembly.
7. Use sleeve installed in press to compress spring retainer (Figure 2, Item 9).
8. Install retaining ring (Figure 2, Item 10) on third clutch assembly through opening in sleeve. Remove sleeve.
9. Install outer clutch disc (Figure 2, Item 8) on third clutch assembly. Install one only, coated lightly with lubricating oil.
10. Install inner clutch disc (Figure 2, Item 7) on third clutch assembly. Install one only, coated lightly with lubricating oil.
11. Install outer clutch discs (Figure 2, Item 8) and inner clutch discs (Figure 2, Item 7) on third clutch assembly. Coat remaining discs lightly with lubricating oil. Alternate outer and inner disc until all are installed (last disc installed is inner clutch disc).
12. Install clutch disc backing plate (Figure 2, Item 6) on third clutch assembly.
13. Install new retaining ring (Figure 2, Item 5) on third clutch assembly.
14. Invert third clutch shaft drum and plug assembly (Figure 2, Item 15).
15. Use sleeve and mallet to install third clutch shaft front bearing (Figure 2, Item 4) on third clutch assembly.
16. Install new third clutch shaft front bearing locating ring (Figure 2, Item 3) on third clutch assembly.
17. Install new retaining ring (Figure 2, Item 2) on third clutch assembly.
18. Install two new third clutch shaft piston rings (Figure 2, Item 1) on third clutch assembly.



ASSEMBLY - CONTINUED

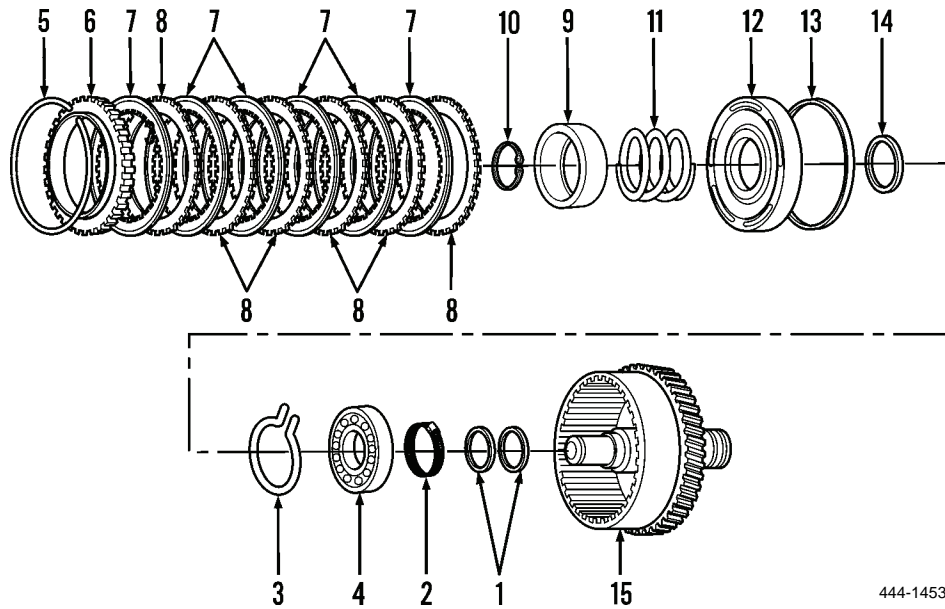

444-1453

Figure 2. Third Clutch.

END OF TASK

END OF WORK PACKAGE



---

# GENERAL SUPPORT MAINTENANCE INSTRUCTIONS

## FORWARD CLUTCH REPAIR Disassembly, Cleaning, Inspection, Assembly

---

### INITIAL SETUP

#### Maintenance Level

General Support

#### Tools and Special Tools

Tool kit, general mechanic's (Item 15, WP 0309)  
Shop equipment, common no. 1 (Item 2, WP 0309)  
Arbor press, 1/2-ton capacity  
Rod, 6 in. long x 3/8-in. diameter  
Sleeve, 6 in. long, 3-1/4 in. OD, 2-3/4 in. ID with a  
1-1/2 in. x 1 in. opening

#### Materials/Parts

Cleaning compound, solvent (Item 10, WP 0310)  
Lubricating oil, OE/HDO-15/40 (Item 21, WP  
0310)  
Rag, wiping (Item 26, WP 0310)  
Piston ring  
Piston seal  
Retaining ring

#### Equipment Condition

Forward clutch removed from transmission (WP  
0293)

---

**DISASSEMBLY**

1. Remove three forward shaft piston rings (Figure 1, Item 1) and discard.

**NOTE**

The outer clutch disc next to the clutch piston will have a backing ring on it.

2. Remove retaining ring (Figure 1, Item 2), clutch disc backing plate (Figure 1, Item 3), eight inner clutch discs (Figure 1, Item 4), and outer clutch discs (Figure 1, Item 5). Discard retaining ring.

**NOTE**

Use sleeve (with opening) installed in press for removing retaining ring, piston return spring spacer, and piston return springs.

3. Compress piston return spring spacer (Figure 1, Item 7) and remove retaining ring (Figure 1, Item 6) through opening in sleeve. Discard retaining ring.
4. Carefully and slowly release pressure on piston return spring spacer (Figure 1, Item 7) and remove piston return spring spacer and sleeve.
5. Remove five piston return springs (Figure 1, Item 8).
6. Invert forward shaft drum and plug assembly (Figure 1, Item 12).

**NOTE**

Tap forward shaft drum and plug assembly on block of wood to remove clutch piston.

7. Remove clutch piston (Figure 1, Item 9).
8. Remove outer clutch piston seal (Figure 1, Item 10) and inner clutch piston seal (Figure 1, Item 11) and discard.

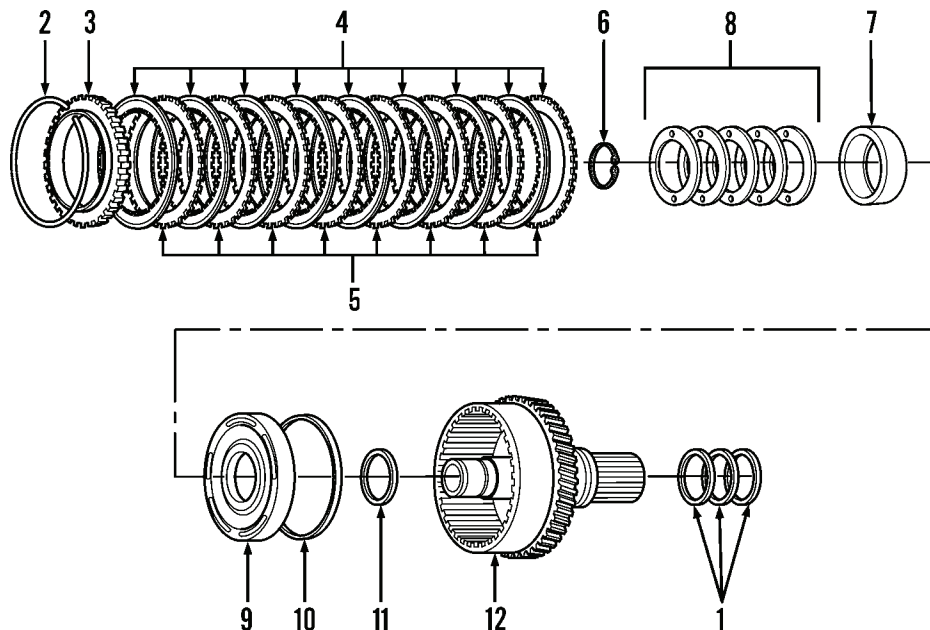

444-1470

**Figure 1. Forward Clutch.**

**END OF TASK**

**CLEANING****WARNING**

- Solvent cleaning compound MIL-PRF-680 Type III is an environmentally compliant and low toxic material. However, it may be irritating to the eyes and skin. Use protective gloves and goggles. Use in well-ventilated areas. Keep away from open flames and other sources of ignition. Failure to do so may result in injury or death to personnel.
- Particles blown by compressed air are hazardous. DO NOT exceed 15 PSI (103 kPa) nozzle pressure when drying parts with compressed air. DO NOT direct compressed air against human skin. Make sure air stream is directed away from user and other personnel in the area. To prevent injury, user must wear protective goggles or face shield. Failure to follow this warning may result in injury to personnel.

Clean all parts with solvent cleaning compound. Immerse parts in solvent cleaning compound and move slowly up and down until parts are thoroughly cleaned. Dry parts thoroughly using compressed air or clean rags.

**END OF TASK****INSPECTION**

1. Inspect forward shaft drum and plug assembly (Figure 1, Item 12) teeth for wear, pits, cracks, nicks, and scores. Inspect shaft and quills to make certain they are not sprung, bent, or have twisted splines and that shafts are true. Inspect overall for wear, cracks, distortion, and damage. If any of these conditions are observed, replace forward shaft drum and plug assembly.
2. Inspect inner clutch discs (Figure 1, Item 4) and outer clutch discs (Figure 1, Item 5). Replace disc if worn, cracked, damaged, or broken.
3. Inspect piston return springs (Figure 1, Item 8). Replace if cracked, worn, distorted, broken, or permanently set.
4. Inspect all other parts for wear, cracks, distortion, and damage. If any of these conditions are observed, replace part.

**END OF TASK****ASSEMBLY****CAUTION**

Be careful not to damage outer and inner clutch piston seals.

**NOTE**

Outer and inner clutch piston seals must be sized before installing clutch piston (Figure 1, Item 9) into drum and plug.

1. Size outer clutch piston seal (Figure 1, Item 10) by rotating clutch piston (Figure 1, Item 9) while holding a round object against new seal. Rotate clutch piston until seal is flush with outer diameter of clutch piston.
2. Lubricate outer clutch piston seal (Figure 1, Item 10) with lubricating oil and install.
3. Size outer clutch piston seal (Figure 1, Item 10) by rotating clutch piston (Figure 1, Item 9) while holding a round object against new seal. Rotate clutch piston until seal is flush with outer diameter of clutch piston.

**ASSEMBLY - CONTINUED**

4. Lubricate inner clutch piston seal (Figure 2, Item 11) with lubricating oil and install.
5. Install clutch piston (Figure 2, Item 9) on forward shaft drum and plug assembly (Figure 2, Item 12).

**NOTE**

- Position first piston return spring with curved side up, then alternate the remaining piston return springs.
  - Use sleeve (with opening) installed in press.
6. Position piston spring spacer (Figure 2, Item 7), five piston return springs (Figure 2, Item 8), and retaining ring (Figure 2, Item 6) through opening in sleeve.
  7. Compress piston spring spacer (Figure 2, Item 7) and install retaining ring (Figure 2, Item 6).
  8. Apply light film of lubricating oil to outer clutch disc (Figure 2, Item 5) and install outer clutch disc with backing ring only.
  9. Apply light film of lubricating oil to only one inner clutch disc (Figure 2, Item 4) and install.
  10. Apply light film of lubricating oil on remaining outer clutch discs (Figure 2, Item 5) and inner clutch discs (Figure 2, Item 4) and install discs by alternating outer and inner discs until all are installed (last disc installed is an inner clutch disc).
  11. Install clutch disc backing plate (Figure 2, Item 3), retaining ring (Figure 2, Item 2), and three forward shaft piston rings (Figure 2, Item 1).

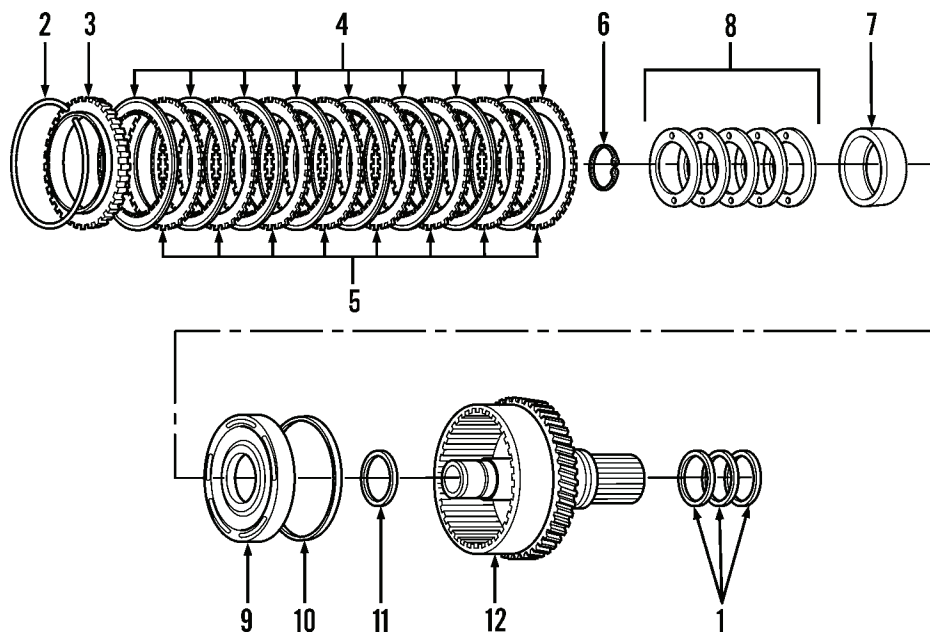

444-1470

**Figure 2. Forward Clutch.**

12. Install forward clutch to transmission (WP 0293).

**END OF TASK****END OF WORK PACKAGE**

---

# GENERAL SUPPORT MAINTENANCE INSTRUCTIONS

## CONTROL VALVE REPAIR

### Disassembly, Cleaning, Inspection, Assembly

---

#### INITIAL SETUP

##### Maintenance Level

General Support

##### Tools and Special Tools

Tool kit, general mechanic's (Item 15, WP 0309)

##### Materials/Parts

Cleaning compound, solvent (Item 10, WP 0310)

Lubricating oil, OE/HDO-15/40 (Item 21, WP 0310)

Permatex (Item 30, WP 0310)

Rag, wiping (Item 26, WP 0310)

##### Materials/Parts - Continued

Lockwasher (2)

O-ring

Oil seal (2)

Piston seal

Seal

##### Equipment Condition

Control valve removed from transmission (WP 0250)

---

## DISASSEMBLY

1. Remove two detent springs (Figure 1, Item 1) and detent balls (Figure 1, Item 2) from control valve housing (Figure 1, Item 25).
2. Remove back-up alarm switch (Figure 1, Item 3) and two pipe plugs (Figure 1, Item 8) from control valve housing (Figure 1, Item 25).
3. Remove two screws (Figure 1, Item 4) and lockwashers (Figure 1, Item 5) from neutral start switch (Figure 1, Item 6). Discard lockwashers.
4. Remove neutral start switch (Figure 1, Item 6) and actuating pin (Figure 1, Item 7) from control valve housing (Figure 1, Item 25).
5. Remove valve spool stop (Figure 1, Item 9) from control valve housing (Figure 1, Item 25).
6. Remove hydraulic actuator assembly (Figure 1, Item 11), declutch valve spool (Figure 1, Item 12), and valve spool spring (Figure 1, Item 13) from control valve housing (Figure 1, Item 25).
7. Remove glad ring (Figure 1, Item 18), inching piston spring (Figure 1, Item 19), piston seal (Figure 1, Item 20), spring retainer pin (Figure 1, Item 21), balance spring (Figure 1, Item 22), O-ring (Figure 1, Item 23), and seal (Figure 1, Item 24) from hydraulic actuator assembly (Figure 1, Item 11). Discard piston seal, O-ring, and seal.
8. Remove two valve spool stops (Figure 1, Item 10) from control valve housing (Figure 1, Item 25).
9. Remove speed selector spool and plug assembly (Figure 1, Item 14) from control valve housing (Figure 1, Item 25).
10. Remove plug (Figure 1, Item 15) from speed selector spool and plug assembly (Figure 1, Item 14).
11. Remove forward and reverse spool (Figure 1, Item 16) from control valve housing (Figure 1, Item 25).
12. Carefully pry two oil seals (Figure 1, Item 17) from control valve housing (Figure 1, Item 25). Discard oil seals.

## END OF TASK

## CLEANING



WARNING



- Solvent cleaning compound MIL-PRF-680 Type III is an environmentally compliant and low toxic material. However, it may be irritating to the eyes and skin. Use protective gloves and goggles. Use in well-ventilated areas. Keep away from open flames and other sources of ignition. Failure to do so may result in injury or death to personnel.
- Particles blown by compressed air are hazardous. DO NOT exceed 15 PSI (103 kPa) nozzle pressure when drying parts with compressed air. DO NOT direct compressed air against human skin. Make sure air stream is directed away from user and other personnel in the area. To prevent injury, user must wear protective goggles or face shield. Failure to follow this warning may result in injury to personnel.

Clean all parts with solvent cleaning compound. Immerse parts in solvent cleaning compound and move slowly up and down until parts are thoroughly cleaned. Dry parts thoroughly using compressed air or clean rags.



CLEANING - CONTINUED

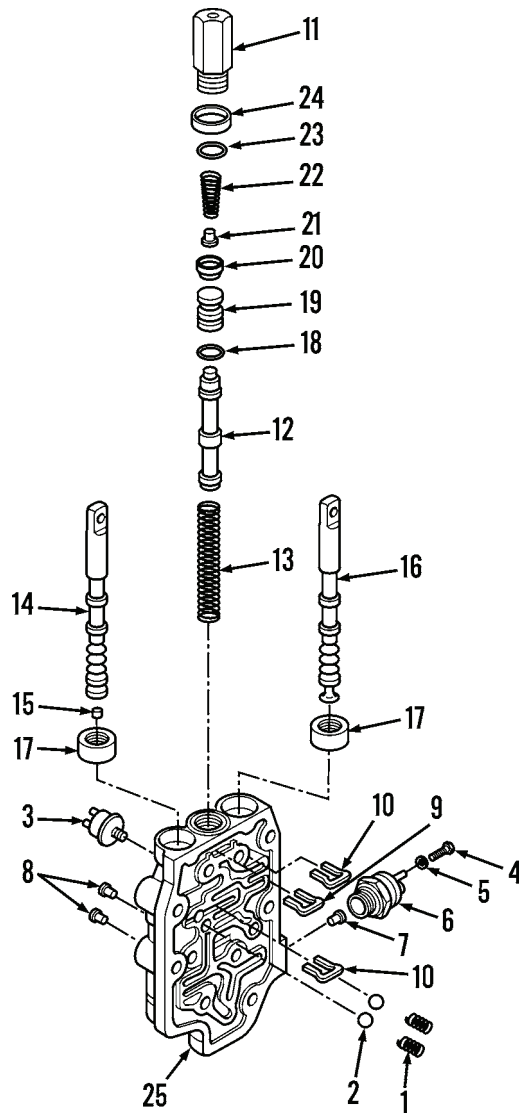

444-1471

Figure 1. Control Valve.

END OF TASK

## INSPECTION

1. Inspect seats and spool bores of control valve housing (Figure 2, Item 25) for cracks, wear, damage, and distortion. If any of these conditions are observed, replace part.
2. Inspect declutch valve spool (Figure 2, Item 12), speed selector spool (Figure 2, Item 14), and forward and reverse spool (Figure 2, Item 16) for wear, damage, bent or broken condition, and distortion. If any of these conditions are observed, replace part.
3. Inspect detent balls (Figure 2, Item 2) for flat or out-of-round condition, cracks, and other damage. Replace if any of these conditions are observed.
4. Inspect detent springs (Figure 2, Item 1) and balance spring (Figure 2, Item 22). Replace if cracked, worn, distorted, broken, or permanently set.
5. Check back-up alarm switch (Figure 2, Item 3) for cracked insulating material around body or terminals. Check for loose, missing, and corroded terminals. Replace if any of these conditions are observed. Check neutral start switch (Figure 2, Item 6) for cracked body and corrosion in terminal contact area. Replace if any of these conditions are observed.
6. Inspect all other parts for wear, damage, cracks, and distortion. Replace part if any of these conditions are observed.

## END OF TASK

## ASSEMBLY

### NOTE

- Immerse all parts in lubricating oil before assembling.
  - Apply a light coat of Permatex 2 around outer diameters of new seal and new piston seal before installing.
1. Install new seal (Figure 2, Item 24), new O-ring (Figure 2, Item 23), balance spring (Figure 2, Item 22), spring retainer pin (Figure 2, Item 21), new piston seal (Figure 2, Item 20), inching piston spring (Figure 2, Item 19), and glad ring (Figure 2, Item 18) on hydraulic actuator assembly (Figure 2, Item 11).

### NOTE

- Apply light coat of Permatex 2 around outer diameter of new oil seals before installing.
  - Oil seals are properly installed when flush with top of control valve housing.
2. Install two new oil seals (Figure 2, Item 17) in control valve housing (Figure 2, Item 25).

### CAUTION

When installing spools in control valve housing, be careful not to damage oil seals.

3. Install forward and reverse spool (Figure 2, Item 16) in control valve housing (Figure 2, Item 25).
4. Install plug (Figure 2, Item 15) in speed selector spool and plug assembly (Figure 2, Item 14).
5. Install speed selector spool and plug assembly (Figure 2, Item 14) in control valve housing (Figure 2, Item 25).
6. Install two valve spool stops (Figure 2, Item 10).
7. Install valve spool spring (Figure 2, Item 13), declutch valve spool (Figure 2, Item 12), and hydraulic actuator assembly (Figure 2, Item 11) in control valve housing (Figure 2, Item 25).
8. Install valve spool stop (Figure 2, Item 9).
9. Install two pipe plugs (Figure 2, Item 8), actuating pin (Figure 2, Item 7), and neutral start switch (Figure 2, Item 6) in control valve housing ((Figure 2, Item 25).

**ASSEMBLY - CONTINUED**

**NOTE**

If neutral start switch has been replaced, perform step 10. Otherwise proceed to step 11.

10. Modify new neutral start switch (Figure 2, Item 6) by carefully removing two terminal studs by unscrewing them.
11. Install two new lockwashers (Figure 2, Item 5) and screws (Figure 2, Item 4) in neutral start switch (Figure 2, Item 6) terminal holes.
12. Install back-up alarm switch (Figure 2, Item 3), two detent balls (Figure 2, Item 2), and detent springs (Figure 2, Item 1) in control valve housing (Figure 2, Item 25).
13. Install control valve on transmission (WP 0250).

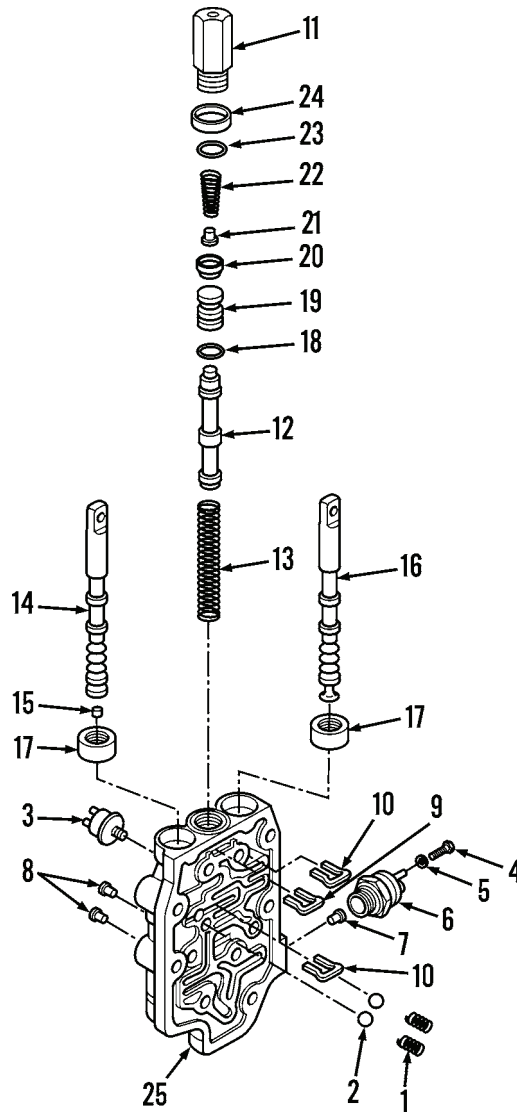

444-1471

**Figure 2. Control Valve.**

**END OF TASK**

**END OF WORK PACKAGE**



---

# GENERAL SUPPORT MAINTENANCE INSTRUCTIONS

## DIFFERENTIAL CARRIER REPAIR

### Disassembly, Cleaning, Inspection, Assembly, Adjustment

---

#### INITIAL SETUP

##### Maintenance Level

General Support

##### Tools and Special Tools

Tool kit, general mechanic's (Item 15, WP 0309)

Shop equipment, basic (Item 1, WP 0309)

Shop equipment, common no. 1 (Item 2, WP 0309)

Shop equipment, common no. 2 (Item 3, WP 0309)

Arbor press, 1/2-ton capacity

Bar, 2-in. diameter x 6 ft long

Capscrew (2), 3/8-16 x 2 UNC

##### Materials/Parts

Cleaning compound, solvent (Item 10, WP 0310)

Cloth, crocus (Item 12, WP 0310)

Linseed oil (Item 18, WP 0310)

Lubricating oil, OE/HDO-10 (Item 20, WP 0310)

Rag, wiping (Item 26, WP 0310)

Red lead (Item 27, WP 0310)

Cotter pin (2)

##### References

WP 0302

##### Equipment Condition

Differential carrier removed from axle and mounted in carrier repair stand (WP 0255 or WP 0256)

---

**DISASSEMBLY**

1. At differential case and gear assembly (Figure 1, Item 4), measure backlash of ring gear. Record for assembly (refer to *Adjustment*, step 2 in this work package).
2. At differential carrier (Figure 1, Item 27), center-punch bearing cap (Figure 1, Item 3) and one differential carrier leg for reference at assembly.
3. Remove four capscrews (Figure 1, Item 1), washers (Figure 1, Item 2), and two bearing caps (Figure 1, Item 3).
4. Remove differential case and gear assembly (Figure 1, Item 4). Insert bar through differential case and gear assembly (Figure 1, Item 4) to aid in lifting assembly out.
5. Remove two cotter pins (Figure 1, Item 5). Discard cotter pins.
6. Remove two bearing adjustment rings (Figure 1, Item 6) and bearing cups (Figure 1, Item 7).

**NOTE**

To repair differential case and gear assembly, refer to WP 0302.

7. At pinion shaft (Figure 1, Item 19), remove nut (Figure 1, Item 8). Use tool to hold yoke.
8. Remove washer (Figure 1, Item 9) and shims (Figure 1, Items 10, 11, and 12).
9. Remove yoke (Figure 1, Item 13) from pinion shaft (Figure 1, Item 19).
10. Remove oil slinger (Figure 1, Item 14) from yoke (Figure 1, Item 13).
11. At pinion cage (Figure 1, Item 17), remove eight capscrews (Figure 1, Item 16) and washers (Figure 1, Item 17).
12. Remove pinion cage (Figure 1, Item 17) from differential carrier (Figure 1, Item 27). Install two 3/8-16 x 2 UNC capscrews in pinion cage puller holes. Turn each capscrew equally to prevent damage to differential carrier, pinion shaft, or bearings.
13. Remove shim pack (Figure 1, Item 18). Wire shims together.
14. Remove pinion shaft (Figure 1, Item 19). Tap pinion shaft out of pinion cage (Figure 1, Item 17) using soft mallet, or press out of pinion cage.
15. Remove outer bearing cone (Figure 1, Item 20) and seal (Figure 1, Item 14A) from pinion cage (Figure 1, Item 17).
16. Remove inner bearing cup (Figure 1, Item 21). Press from pinion cage (Figure 1, Item 17).
17. Remove outer bearing cup (Figure 1, Item 22). Press from pinion cage (Figure 1, Item 17).
18. At pinion shaft (Figure 1, Item 19), use puller to remove inner bearing cone (Figure 1, Item 23).
19. Remove retaining ring (Figure 1, Item 24) and use puller to remove roller bearing (Figure 1, Item 25) from pinion shaft (Figure 1, Item 19).
20. Remove plug (Figure 1, Item 26) from differential carrier (Figure 1, Item 27).

DISASSEMBLY - CONTINUED

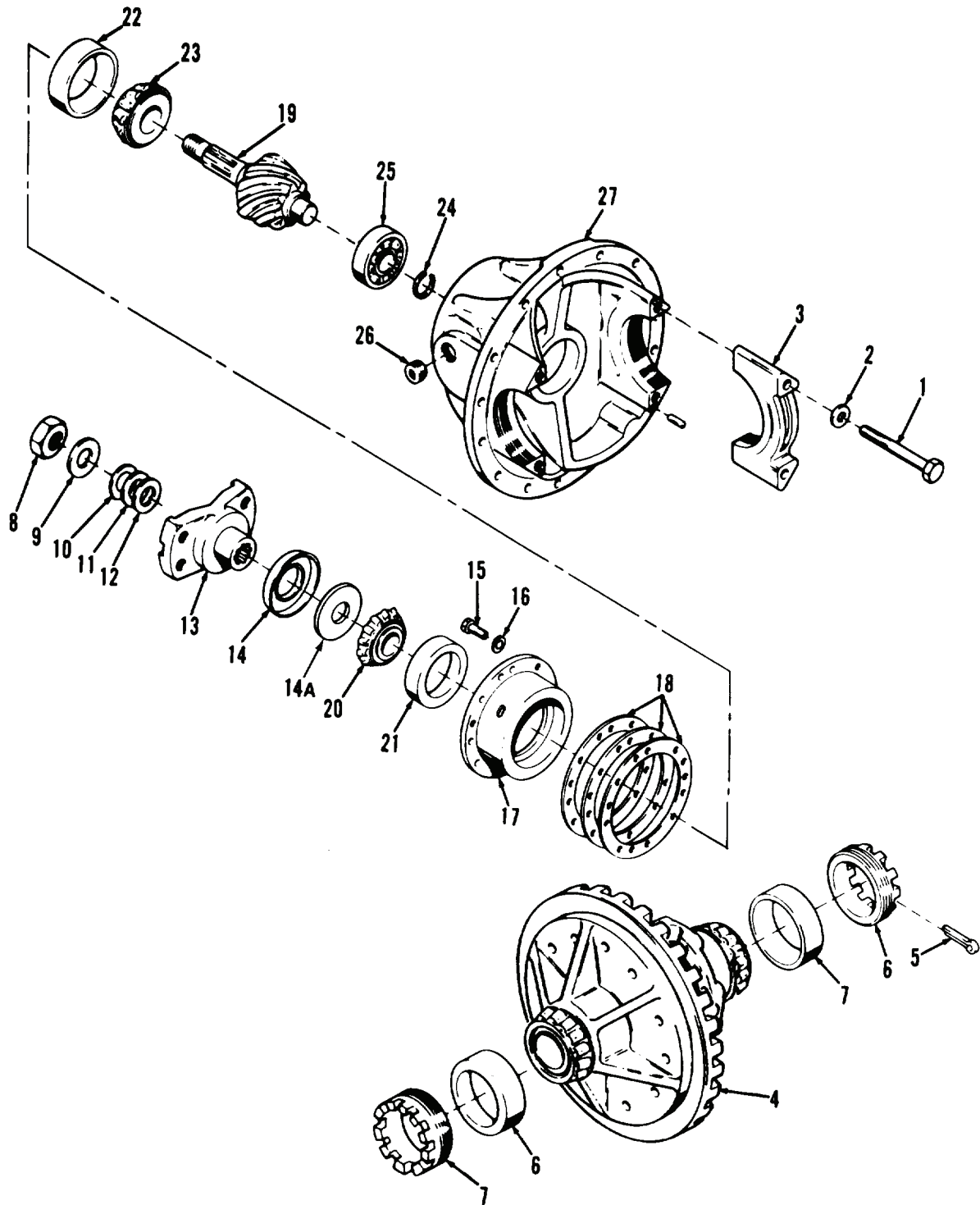

Figure 1. Differential Carrier.

TA326466

END OF TASK

**CLEANING****WARNING**

Solvent cleaning compound MIL-PRF-680 Type III is an environmentally compliant and low toxic material. However, it may be irritating to the eyes and skin. Use protective gloves and goggles. Use in well-ventilated areas. Keep away from open flames and other sources of ignition. Failure to do so may result in injury or death to personnel.

1. Clean bearings by soaking in solvent cleaning compound. Dry with clean, soft, lint-free, absorbent rags. Do not use compressed air to dry bearings.

**CAUTION**

Do not immerse differential case and gear assembly in cleaning solvent.

**NOTE**

If differential case and gear assembly has been repaired as described WP 0302, do not perform step 2.

2. Clean differential case and gear assembly with clean, soft, lint-free, absorbent rags moistened with solvent cleaning compound to remove dirt and lubricant.
3. Clean all other parts with solvent cleaning compound. Dry with clean, soft, lint-free, absorbent rags.

**END OF TASK****INSPECTION****NOTE**

Immediately after performing inspection, coat all parts with light lubricating oil to prevent corrosion.

1. Inspect bearings and bearing cups. Check for wear, pitting, and damage. Replace if defective.
2. Inspect pinion shaft. Check gear teeth and splines for nicked, cracked, broken, scored, and worn condition. Remove burrs or nicks with soft hone or crocus cloth. Replace if damaged or worn.

**NOTE**

Pinion shaft and ring gear must be replaced as a matched set.

3. Inspect two bearing adjusting rings. Check for wear, damage, and nicks. Check threads for damage. Replace if defective.
4. Inspect pinion cage and differential carrier. Check for cracks, breaks, burrs, and damage to machined surfaces. Remove burrs and minor surface defects with soft hone or crocus cloth. Replace cracked or damaged parts.
5. Inspect yoke. Check for cracks, burrs, twisted splines, and other damage. Remove burrs with soft hone or crocus cloth. Replace if cracked or splines are twisted.
6. Inspect all other parts. Check for damage and wear. Replace if damaged or worn.

**END OF TASK**



**ASSEMBLY**

1. Install plug (Figure 2, Item 26) in differential carrier (Figure 2, Item 27).
2. Press roller bearing (Figure 2, Item 25) on pinion shaft (Figure 2, Item 19).
3. Install retaining ring (Figure 2, Item 24) on pinion shaft to secure roller bearing (Figure 2, Item 25).
4. Press inner bearing cone (Figure 2, Item 23) on pinion shaft (Figure 2, Item 19).
5. Press outer bearing cup (Figure 2, Item 22) into pinion cage (Figure 2, Item 17). Press outer bearing cup firmly against pinion cage shoulder. Lubricate with light lubricating oil.
6. Press inner bearing cup (Figure 2, Item 21) into pinion cage (Figure 2, Item 17). Press inner bearing cup firmly against pinion cage shoulder. Lubricate with light lubricating oil.
7. Install outer bearing cone (Figure 2, Item 20) and seal (Figure 2, Item 14A).
8. Position pinion shaft (Figure 2, Item 19) into pinion cage (Figure 2, Item 17).
9. Press outer bearing cone and seal (Figure 2, Item 14) on pinion shaft (Figure 2, Item 19).
10. Position shim pack (Figure 2, Item 18) on pinion cage (Figure 2, Item 17). Use original shim pack (remove wire before installing) or equivalent thickness.
11. Install pinion cage (Figure 2, Item 17) on differential carrier (Figure 2, Item 27) with eight washers (Figure 2, Item 16) and capscrews (Figure 2, Item 15). Tighten capscrews to 60 to 75 lb-ft (81 to 102 Nm).
12. Press oil slinger (Figure 2, Item 14) on yoke (Figure 2, Item 13).
13. Position yoke (Figure 2, Item 13) on pinion shaft (Figure 2, Item 19).
14. Install three shims (Figure 2, Items 10, 11, and 12) on pinion shaft (Figure 2, Item 19).
15. Install washer (Figure 2, Item 9) and nut (Figure 2, Item 8). Tighten nut to 300 to 400 lb-ft (407 to 542 Nm).
16. Check pinion shaft (Figure 2, Item 19) preload. Use inch-pound torque wrench at nut (Figure 2, Item 8) to check bearing preload. Correct bearing preload is 5 to 15 lb-in. (0.6 to 1.7 Nm). If torque is not within these limits, remove pinion cage (Figure 2, Item 17) and add shims (Figure 2, Item 18) to decrease preload or remove shims to increase preload.
17. Install two bearing caps (Figure 2, Item 3) on differential carrier (Figure 2, Item 27) with four washers (Figure 2, Item 2) and capscrews (Figure 2, Item 1). Tighten capscrews to 160 to 190 lb-ft (217 to 258 Nm).
18. Ensure two bearings cups (Figure 2, Item 7) can be pushed into bores by hand. If necessary, rework bores using emery cloth until hand-push fit is obtained. After hand-push fit is obtained, remove capscrews (Figure 2, Item 1), washers (Figure 2, Item 2), and bearing caps (Figure 2, Item 3).
19. Position differential carrier (Figure 2, Item 27) to accept differential case and gear assembly (Figure 2, Item 4). Position differential case and gear assembly on differential carrier using bar.
20. Position two bearing cups (Figure 2, Item 7) and bearing adjusting rings (Figure 2, Item 6) on bar.
21. Raise bar and install two bearing cups (Figure 2, Item 7) and bearing adjusting rings (Figure 2, Item 6) on differential case and gear assembly (4).

**CAUTION**

In step 22, be careful not to cross-thread bearing adjusting rings.

22. Position two bearing caps (Figure 2, Item 3) on differential carrier (Figure 2, Item 27) with match marks aligned.
23. Install four washers (Figure 2, Item 2) and capscrews (Figure 2, Item 1). Do not fully tighten capscrews.

**END OF TASK**

---

**ADJUSTMENT**

1. Perform differential bearing preload as follows:
  - a. Mount dial indicator as shown below. Loosen bearing adjusting ring (Figure 2, Item 6) on opposite side of gear sufficient to notice end play on dial indicator. Then, tighten same bearing ring adjusting sufficiently to obtain zero end play.
  - b. Check ring gear runout. If runout exceeds 0.008 in. (0.20 mm), remove differential case and gear assembly (Figure 2, Item 4) and determine cause.
  - c. Tighten bearing adjusting rings (Figure 2, Item 6). Tighten both rings one notch each from zero end play to preload differential bearings.
2. Perform ring gear backlash check. Mount dial indicator as shown. Ring gear backlash should be as recorded in step 1 of *Disassembly*. If necessary, adjust as described in steps 3 and 4.

**NOTE**

In step 3, ensure each bearing adjusting ring is moved the same distance to maintain bearing end play adjustment.

3. Adjust backlash by backing off one bearing adjusting ring (Figure 2, Item 6) and advancing opposite bearing adjusting ring an equal amount.

**NOTE**

For new ring gear and pinion shaft, adjust backlash to 0.010 in. (0.25 mm).

4. Perform gear tooth contact check. Use mixture of red lead and linseed oil. Rotate ring gear through one complete revolution in each direction. Compare tooth pattern against the following illustration. Adjust backlash to move ring gear or adjust pinion cage shim pack (Figure 2, Item 18) to move pinion shaft (Figure 2, Item 19), as necessary, to obtain correct tooth contact pattern.
5. Install new cotter pin (Figure 2, Item 5) in each of two bearing adjusting rings (Figure 2, Item 6).
6. Tighten four capscrews (Figure 2, Item 1) to 160 to 190 lb-ft (217 to 258 Nm).

ADJUSTMENT - CONTINUED

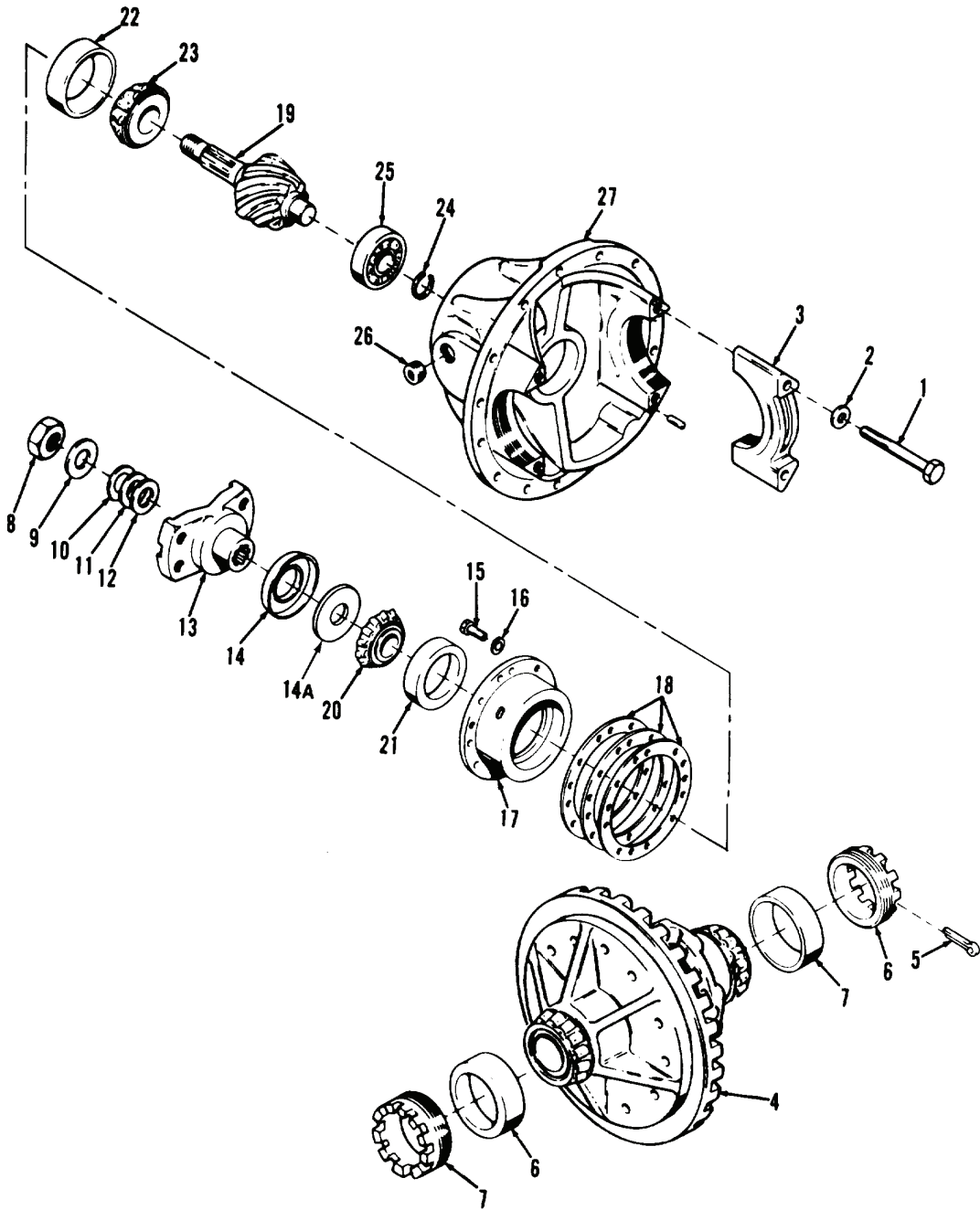

TA326466

Figure 2. Differential Carrier.

END OF TASK

END OF WORK PACKAGE



---

## GENERAL SUPPORT MAINTENANCE INSTRUCTIONS

### MODULATION VALVE REPAIR Disassembly, Cleaning, Inspection, Assembly

---

#### INITIAL SETUP

**Maintenance Level**

General Support

**Tools and Special Tools**

Tool kit, general mechanic's (Item 15, WP 0309)

**Materials/Parts**

Cleaning compound, solvent (Item 10, WP 0310)

**Materials/Parts - Continued**

Lubricating oil, OE/HDO-15/40 (Item 21, WP 0310)

Rag, wiping (Item 26, WP 0310)

O-ring (4)

**Equipment Condition**

Modulation valve assembly removed from transmission (WP 0250)

---

**DISASSEMBLY**

Remove four piston seals (Figure 1, Item 1), O-rings (Figure 1, Item 2), two accumulator valves (Figure 1, Item 3), outer accumulator springs (Figure 1, Item 4), inner accumulator springs (Figure 1, Item 5), regulator springs (Figure 1, Item 6), and regulator spools (Figure 1, Item 7) from modulation valve body (Figure 1, Item 8). Discard O-rings.

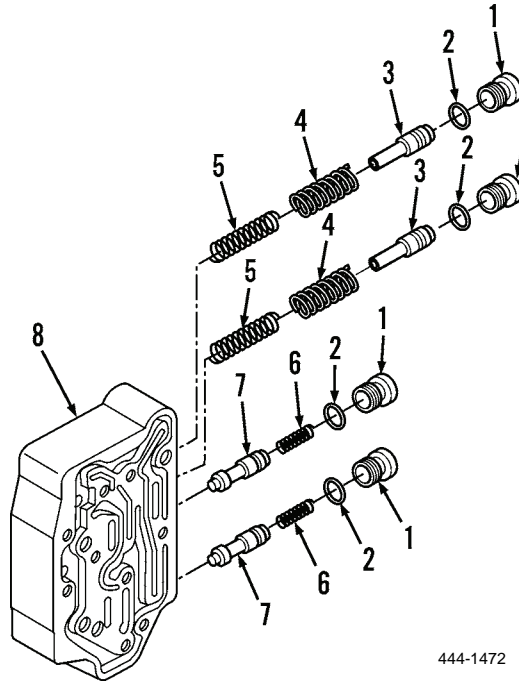

**Figure 1. Modulation Valve.**

**END OF TASK**

**CLEANING****WARNING**

- Solvent cleaning compound MIL-PRF-680 Type III is an environmentally compliant and low toxic material. However, it may be irritating to the eyes and skin. Use protective gloves and goggles. Use in well-ventilated areas. Keep away from open flames and other sources of ignition. Failure to do so may result in injury or death to personnel.
- Particles blown by compressed air are hazardous. DO NOT exceed 15 PSI (103 kPa) nozzle pressure when drying parts with compressed air. DO NOT direct compressed air against human skin. Make sure air stream is directed away from user and other personnel in the area. To prevent injury, user must wear protective goggles or face shield. Failure to follow this warning may result in injury to personnel.

Clean all parts with solvent cleaning compound. Immerse parts in solvent cleaning compound and move slowly up and down until parts are thoroughly cleaned. Dry parts thoroughly using compressed air or clean rags.

**END OF TASK****INSPECTION**

1. Inspect modulation valve body (Figure 1, Item 8). Replace if worn, damaged, distorted, or spool bores cracked or worn.
2. Inspect accumulator valves (Figure 1, Item 3) and regulator spools (Figure 1, Item 7). Replace if damaged, cracked, worn, or distorted.
3. Inspect piston seals (Figure 1, Item 1). Replace if worn, damaged, distorted, or threads cracked or pitted.
4. Inspect outer accumulator springs (Figure 1, Item 4), inner accumulator springs (Figure 1, Item 5), and regulator springs (Figure 1, Item 6). Replace if worn, damaged, cracked, distorted, or permanently set.

**END OF TASK****ASSEMBLY**

1. Lubricate four new O-rings (Figure 1, Item 2) with lubricating oil.
2. Install two regulator spools (Figure 1, Item 7), regulator springs (Figure 1, Item 6), inner accumulator springs (Figure 1, Item 5), outer accumulator springs (Figure 1, Item 4), accumulator valves (Figure 1, Item 3), four new O-rings (Figure 1, Item 2), and piston seals (Figure 1, Item 1) in modulation valve body (Figure 1, Item 8).
3. Install modulation valve assembly on transmission (WP 0250).

**END OF TASK****END OF WORK PACKAGE**





---

## GENERAL SUPPORT MAINTENANCE INSTRUCTIONS

### DIFFERENTIAL CASE AND GEARS REPAIR

Disassembly, Cleaning, Inspection, Assembly

---

#### INITIAL SETUP

##### Maintenance Level

General Support

##### Tools and Special Tools

Tool kit, general mechanic's (Item 15, WP 0309)  
Shop equipment, common no. 1 (Item 2, WP 0309)  
Arbor press, 1/2-ton capacity  
Electric portable drill (NSN 5130-00-889-9004)  
Drill bit

##### Materials/Parts

Cleaning compound, solvent (Item 10, WP 0310)  
Lubricating oil, OE/HDO-10 (Item 20, WP 0310)  
Lubricating oil, gear (Item 22, WP 0310)  
Rag, wiping (Item 26, WP 0310)

##### Equipment Condition

Differential case and gears removed from carrier  
(WP 0300)

---

**DISASSEMBLY**

1. At differential case and gear assembly, use punch or chisel to mark case halves (Figure 1, Items 3 and 4) for correct alignment at assembly.
2. Remove eight capscrews (Figure 1, Item 1) and washers (Figure 1, Item 2) and separate differential case plain half (Figure 1, Item 3) and differential case flange half (Figure 1, Item 4).
3. Remove thrust washer (Figure 1, Item 5) and side gear (Figure 1, Item 6).
4. Remove four thrust washers (Figure 1, Item 7) and pinion gears (Figure 1, Item 8).
5. Remove spider (Figure 1, Item 9).
6. Remove side gear (Figure 1, Item 10) and thrust washer (Figure 1, Item 11).

**NOTE**

If rivets are used to secure ring gear and differential case flange half, proceed to step 8. Otherwise, perform step 7 and disregard step 8.

7. At differential case flange half (Figure 1, Item 4), remove 12 capscrews (Figure 1, Item 12), washers (Figure 1, Item 13), nuts (Figure 1, Item 14), and ring gear (Figure 1, Item 16).
8. At differential case flange half (Figure 1, Item 4), drill out 12 rivets (Figure 1, Item 15). Center punch rivets in center of head. Use drill bit 1/32 in. (0.79 mm) smaller than body of rivet and drill through head. Carefully press out rivets and remove ring gear (Figure 1, Item 16).
9. Use puller to remove bearing cone (Figure 1, Item 17) from differential case flange half (Figure 1, Item 4).
10. User puller to remove bearing cone (Figure 1, Item 18) from differential case plain half (Figure 1, Item 3).

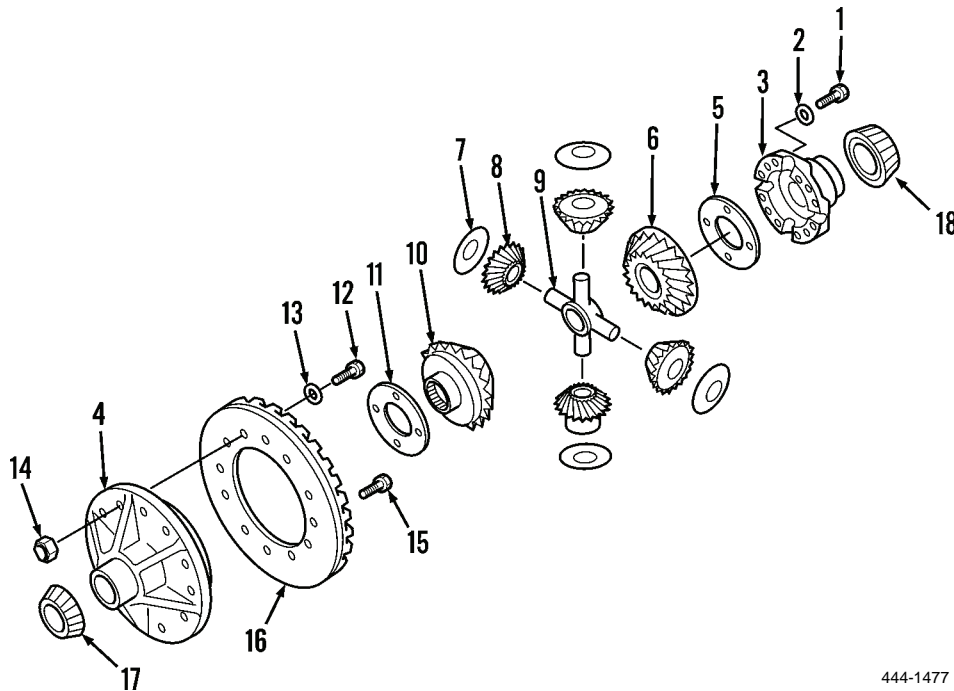

444-1477

**Figure 1. Differential Case and Gears.**

**END OF TASK**

**CLEANING****WARNING**

Solvent cleaning compound MIL-PRF-680 Type III is an environmentally compliant and low toxic material. However, it may be irritating to the eyes and skin. Use protective gloves and goggles. Use in well-ventilated areas. Keep away from open flames and other sources of ignition. Failure to do so may result in injury or death to personnel.

1. Clean bearings with solvent cleaning compound. Dry with clean, soft, lint-free, absorbent rags. Do not use compressed air to dry bearings.
2. Clean all other parts with solvent cleaning compound. Dry with clean rags.

**END OF TASK****INSPECTION****NOTE**

- Ring gear and pinion shaft (WP 0300, Figure 1, Item 19) must be replaced as a matched set. Four pinion gears and side gears must be replaced as a set.
  - Immediately after performing inspection, coat all parts with light lubricating oil to prevent corrosion.
1. Inspect ring gear (Figure 2, Item 16), side gears (Figure 2, Items 6 and 10), and four pinion gears (Figure 2, Item 8) for wear, damage, cracks, pits, and scoring. Inspect gear teeth for wear, cracks, and damage. If any of these conditions are observed, replace part.
  2. Inspect differential case halves (Figure 2, Items 3 and 4), spider (Figure 2, Item 9), and thrust washers (Figure 2, Items 5, 7, and 11) for wear, cracks, pits, scoring, damage, and distortion. If any of these conditions are observed, replace part.

**CAUTION**

Replace thrust washers in sets. Using a combination of old and new thrust washers will result in premature failure.

3. Inspect all other parts for wear, damage, cracks, pits, and distortion. If any of these conditions are observed, replace part.

**END OF TASK**

**ASSEMBLY****NOTE**

Lubricate all parts and differential case halves inner walls with gear lubricating oil.

1. Position ring gear (Figure 2, Item 16) on differential case flange half (Figure 2, Item 4).

**NOTE**

If rivets were used to secure ring gear and differential case flange half, use capscrews, washers, and nuts instead of rivets.

2. Install 12 washers (Figure 2, Item 13), capscrews (Figure 2, Item 12), and nuts (Figure 2, Item 14). Tighten nuts to 90 to 120 lb-ft (122 to 163 Nm).
3. Install thrust washer (Figure 2, Item 11) and side gear (Figure 2, Item 10) on differential case flange half (Figure 2, Item 4).
4. Position four pinion gears (Figure 2, Item 8) and four thrust washers (Figure 2, Item 7) on spider (Figure 2, Item 9).
5. Install spider (Figure 2, Item 9) assembly on side gear (Figure 2, Item 10).
6. Install side gear (Figure 2, Item 6) and thrust washer (Figure 2, Item 5).
7. Align match marks and install differential case plain half (Figure 2, Item 3) on differential case flange half (Figure 2, Item 4) with eight washers (Figure 2, Item 2) and capscrews (Figure 2, Item 1). Install four equally spaced capscrews first, and draw assembly together. Check for free rotation of gears and correct if necessary. Install four remaining capscrews and washers. Tighten capscrews to 90 to 120 lb-ft (122 to 163 Nm).
8. Use press to install bearing cones (Figure 2, Items 17 and 18). Press squarely and firmly.

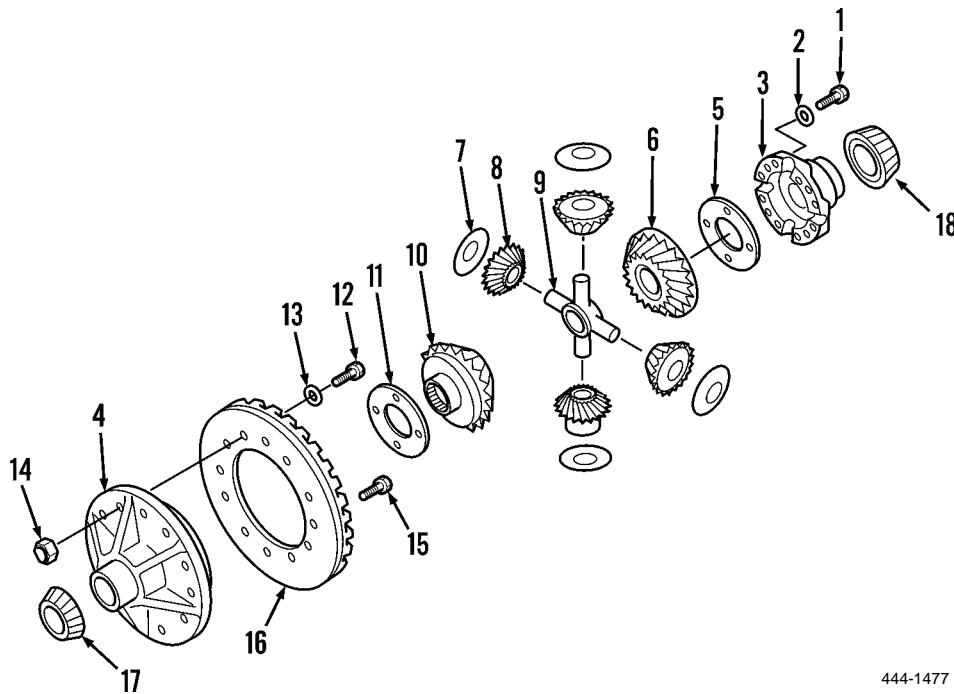

444-1477

**Figure 2. Differential Case and Gears.**

**END OF TASK**

**END OF WORK PACKAGE**

---

## GENERAL SUPPORT MAINTENANCE INSTRUCTIONS

### REAR AXLE TRUNNION REPLACEMENT

#### Removal, Cleaning, Inspection, Installation

---

#### INITIAL SETUP

**Maintenance Level**

General Support

**Tools and Special Tools**

Tool kit, general mechanic's (Item 15, WP 0309)  
Shop equipment, common no. 1 (Item 2, WP 0309)  
Chain hoist and eyebolts  
Wood blocks (2), 6 x 6 x 18 in.

**Materials/Parts**

Cleaning compound, solvent (Item 10, WP 0310)  
Rag, wiping (Item 26, WP 0310)  
Locknut (2)

**Personnel Required**

Two

**References**

LO 10-3930-638-12

**Equipment Condition**

Vehicle parked on level surface  
Engine OFF  
Front wheels blocked  
Shipping lock pin installed (WP 0044)  
Rear chassis raised (use chain hoist) and securely blocked  
Rear wheels and tires removed (WP 0169)  
Rear drive shaft disconnected from rear axle differential companion yoke (WP 0156)  
Brake hoses and lines disconnected from rear axle housing and rear wheel cylinders (WP 0164)  
Rear axle housing removed from vehicle (WP 0254)

---

**REMOVAL**

1. Remove two grease fittings (Figure 1, Item 1).
2. Use chain hoist with eyebolts to raise and support trunnion (Figure 1, Item 6) ends to relieve force on pivot pins (Figure 1, Item 5).

**WARNING**

Be sure vehicle is securely blocked and chain hoist is securely attached to trunnion before performing the following steps. Failure to do so may result in injury or death to personnel.

**NOTE**

If necessary, use chain wrench or pipe wrench on grease fitting end of pivot pin to prevent pin from turning.

3. Remove two locknuts (Figure 1, Item 2), small washers (Figure 1, Item 3), and large washers (Figure 1, Item 4). Discard locknuts.
4. Remove two pivot pins (Figure 1, Item 5) by tapping threaded ends of pivot pins using brass drift and hammer.

**NOTE**

Remove bushings only if necessary for replacement.

5. Remove two bushings (Figure 1, Item 7) by pressing from trunnion (Figure 1, Item 6) using rod that will contact outer race of bushing.

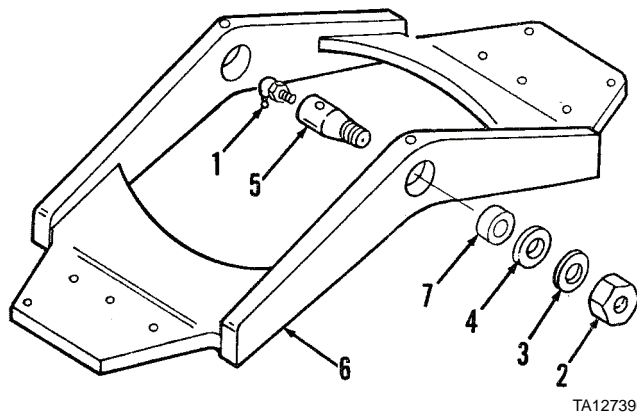

**Figure 1. Rear Axle Trunnion.**

**END OF TASK**

**CLEANING****WARNING**

- Solvent cleaning compound MIL-PRF-680 Type III is an environmentally compliant and low toxic material. However, it may be irritating to the eyes and skin. Use protective gloves and goggles. Use in well-ventilated areas. Keep away from open flames and other sources of ignition. Failure to do so may result in injury or death to personnel.
- Particles blown by compressed air are hazardous. DO NOT exceed 15 PSI (103 kPa) nozzle pressure when drying parts with compressed air. DO NOT direct compressed air against human skin. Make sure air stream is directed away from user and other personnel in the area. To prevent injury, user must wear protective goggles or face shield. Failure to follow this warning may result in injury to personnel.

Clean all parts with solvent cleaning compound. Dry thoroughly with moisture-free compressed air.

**END OF TASK****INSPECTION**

1. Inspect grease fittings (Figure 2, Item 1) and pivot pins (Figure 2, Item 5). Replace if cracked, broken, or threads damaged.
2. Inspect washers (Figure 2, Items 3 and 4) and bushings (Figure 2, Item 7). Replace if scored, worn, or damaged.
3. Inspect trunnion (Figure 2, Item 6). Repair by welding if cracked or welds broken. Replace if severely cracked or otherwise damaged.

**END OF TASK**

**INSTALLATION**

1. Install two bushings (Figure 2, Item 7) on trunnion (Figure 2, Item 6) by using rod that will contact outer race of bushing, and pressing bushing into pivot bore of trunnion until flush with surface of trunnion.
2. Use chain hoist with eyebolts to raise and position trunnion (Figure 2, Item 6) until holes in vehicle frame and trunnion are aligned.

**WARNING**

Be sure vehicle is securely blocked and chain hoist is securely attached to trunnion before performing the following steps. Failure to do so may result in injury or death to personnel.

**NOTE**

Make sure pivot pins are clean and free of grease and oil before installation.

3. From inside of trunnion (Figure 2, Item 6), install two pivot pins (Figure 2, Item 5) through trunnion and frame.

**NOTE**

Use chain wrench or pipe wrench on grease fitting end of pivot pin to prevent pin from turning.

4. Install two large washers (Figure 2, Item 4), small washers (Figure 2, Item 3), and new locknuts (Figure 2, Item 2). Tighten locknuts to 460 to 500 lb-ft (624 to 678 Nm).
5. Install two grease fittings (Figure 2, Item 1) until securely mounted. Lubricate grease fittings (LO 10-3930-638-12).

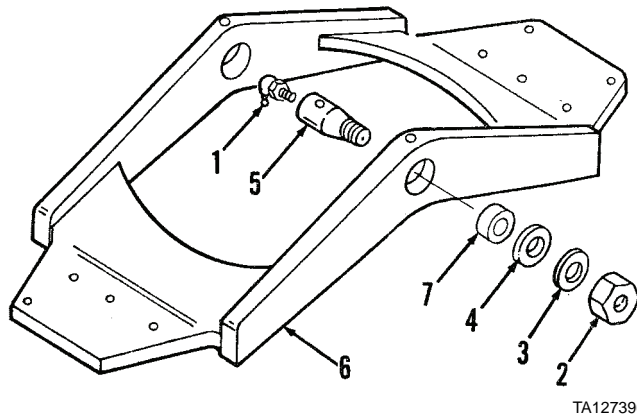

**Figure 2. Rear Axle Trunnion.**

6. Install rear axle housing on vehicle (WP 0254).
7. Connect brake hoses and lines to rear axle housing and rear wheel cylinders (WP 0164).
8. Connect rear drive shaft to rear axle differential companion yoke (WP 0156).
9. Install rear wheels and tires (WP 0169).
10. Lower rear chassis and remove blocks.
11. Remove shipping lock pin (WP 0044).

**END OF TASK****END OF WORK PACKAGE**



# GENERAL SUPPORT MAINTENANCE INSTRUCTIONS

## TORQUE LIMITS

### GENERAL

This work package lists standard torque values for fasteners. Special torque values are indicated in maintenance procedures for applicable components. The general torque values given in this work package shall be used when specific torque values are not indicated in the maintenance procedures.

### TORQUE LIMITS

Torque limits are listed in Table 1 for dry fastener and in Table 2 for wet fasteners. Dry fasteners are defined as fasteners on which no lubricants are applied to the threads; wet fasteners are defined as fasteners on which special graphited or moly-disulphide greases or other extreme pressure lubricants are applied to the threads.

**Table 1. Torque Limits for Dry Fasteners.**

SIZE		TORQUE					
		SAE GRADE No. 2		SAE GRADE No. 5		SAE GRADE No. 8	
INCHES	MILLI METERS	POUNDS FOOT	NEWTON METERS	POUNDS FOOT	NEWTON METERS	POUNDS FOOT	NEWTON METERS
1/4	6.35	5 to 6	6.8 to 8.13	9 to 11	12.2 to 14.9	12 to 15	16.3 to 20.3
5/16	7.94	10 to 12	13.6 to 16.3	17 to 20.5	23.1 to 27.8	24 to 29	32.5 to 39.3
3/8	9.53	20 to 23	27.1 to 31.2	35 to 42	47.5 to 57.0	45 to 54	61.0 to 73.2
7/16	11.11	30 to 35	40.7 to 47.4	54 to 64	73.2 to 86.8	70 to 84	94.9 to 113.9
1/2	12.70	45 to 52	61.0 to 70.5	80 to 96	108.5 to 130.2	110 to 132	149.2 to 179.0
9/16	14.29	65 to 75	88.1 to 101.6	110 to 132	149.2 to 179.0	160 to 192	217.0 to 260.4
5/8	15.88	95 to 105	128.7 to 143.3	150 to 180	203.4 to 244.1	220 to 264	298.3 to 358.0
3/4	19.05	150 to 185	203.3 to 250.7	270 to 324	366.1 to 439.3	380 to 456	515.3 to 518.3
7/8	22.23	160 to 200	216.8 to 271.0	400 to 480	542.4 to 650.9	600 to 720	813.6 to 976.3
1	25.40	250 to 300	338.8 to 406.5	580 to 696	786.5 to 943.8	900 to 1080	1,220.4 to 1,464.5
1-1/8	25.58			800 to 880	1,084.8 to 1,193.3	1,280 to 1,440	1,735.7 to 1,952.8
1-1/4	31.75			1,120 to 1,240	1,518.7 to 1,681.4	1,820 to 2,000	2,467.9 to 2,712.0
1-3/8	34.93			1,460 to 1,680	1,979.8 to 2,278.1	2,380 to 2,720	3,227.3 to 3,688.3
1-1/2	38.10			1,940 to 2,200	2,630.6 to 2,983.2	3,160 to 3,560	4,285.0 to 4,827.4

**TORQUE LIMITS - CONTINUED****Table 2. Torque Limits for Wet Fasteners.**

SIZE		TORQUE					
		SAE GRADE No. 2		SAE GRADE No. 5		SAE GRADE No. 8	
INCHES	MILLI METERS	POUNDS FOOT	NEWTON METERS	POUNDS FOOT	NEWTON METERS	POUNDS FOOT	NEWTON METERS
1/4	6.35	4.5 to 5.5	6.1 to 7.5	8 to 10	10.8 to 13.6	11 to 13.5	14.9 to 18.3
5/16	7.94	9 to 11	12.2 to 14.9	15 to 18.5	20.4 to 25.1	21.5 to 26	29.2 to 35.3
3/8	9.53	18 to 20.5	24.4 to 27.8	31.5 to 38	42.8 to 51.6	40.5 to 48.5	55 to 65.9
7/16	11.11	27 to 31.5	36.7 to 42.8	48.5 to 57.5	65.9 to 78.2	63 to 75.5	85.6 to 102.6
1/2	12.70	40.5 to 47	55 to 63.9	72 to 86.5	97.9 to 117.6	99 to 119	134.6 to 161.8
9/16	14.29	58.5 to 67.5	79.5 to 91.8	99 to 119.0	134.6 to 161.8	144 to 173	195.8 to 235.2
5/8	15.88	85.5 to 94.5	116.2 to 128.5	135 to 162	183.6 to 220.3	198 to 237.5	269.2 to 323
3/4	19.05	135 to 166.5	183.6 to 226.4	243 to 291.5	330.4 to 396.4	342 to 410	465.1 to 557.6
7/8	22.23	144 to 180	195.8 to 224.8	360 to 432	489.6 to 587.5	540 to 648	734.4 to 881.2
1	25.40	225 to 270	360 to 367.2	522 to 626	709.9 to 851.3	810 to 972	1,101.6 to 1,321.9
1-1/8	25.58			720 to 792	979.2 to 1077.1	1,152 to 1,296	1,566.7 to 1,762.5
1-1/4	31.75			1,008 to 1,116	1,370.8 to 1,517.7	1,638 to 1,800	2,227.6 to 2,448
1-3/8	34.93			1,314 to 1,512	1,787 to 2,056.3	2,142 to 2,448	2,430.3 to 3,329.2
1-1/2	38.10			1,746 to 1,980	2,374.5 to 2,692.8	2,844 to 3,204	3,867.8 to 4,357.4

**END OF WORK PACKAGE**

# GENERAL SUPPORT MAINTENANCE INSTRUCTIONS

## ILLUSTRATED LIST OF MANUFACTURED ITEMS

### Introduction, Manufactured Items

#### INTRODUCTION

This work package includes instructions for making items authorized to be manufactured or fabricated at Organizational Maintenance. Dimensions and bulk materials needed for manufacture of the items are provided in the next section.

#### MANUFACTURED ITEMS

The figure below in conjunction with the table provides dimensions and information necessary for the manufactured items.

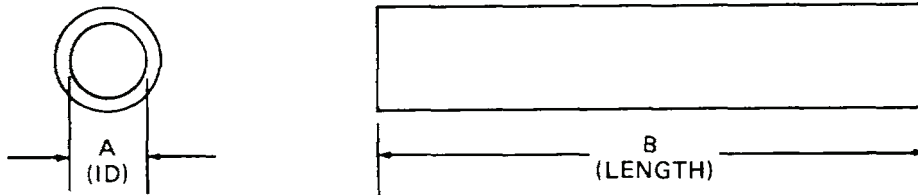

TA127505

PART NUMBER	DESCRIPTION	DIMENSIONS IN IN.		NSN
		A	B	
D64267	Hose, Filter Supply	1/4	31 ± 0.2	4720-00-007-9424
D64267	Hose, Return	1/4	31 ± 0.2	4720-00-007-9424
L102543	Hose, Fuel	1/4	10 ± 0.2	4720-00-374-8125
L102913	Hose, Suction	1-1/4	23	
L60451	Hose, Vent	1/4	27	4720-00-460-2477
L60515	Hose, Vent	1/4	32	4720-00-460-2477
L78902	Hose, Breather	3/4	44 ± 0.5	
L79326	Hose, Fuel Filter	1/4	15	4720-00-374-8125

END OF WORK PACKAGE



---

# GENERAL SUPPORT MAINTENANCE INSTRUCTIONS

## ELECTRICAL AND HYDRAULIC DIAGRAMS

---

### GENERAL

This work package contains electrical diagrams and hydraulic diagrams. Also included in this work package is a description of how to use the electrical diagrams as an aid to troubleshooting.

The hydraulic diagrams are located in Figures 11 and 12. The electrical diagrams are located in Figures 4 through 10.

Figure 11 shows the hydraulic oil flow when various controls are in the neutral position. Figure 12 shows the hydraulic oil flow when the controls are activated.

### HOW TO USE ELECTRICAL SCHEMATIC AS AN AID TO TROUBLESHOOTING

#### Overview

1. Figures 4 through 10, your electrical diagrams, are designed to help you understand the electrical circuits associated with this vehicle. They are generally referred to as “schematics” and use “symbols” to represent real components. They are not drawn to scale (as in a blueprint) nor does the location of the symbols represent actual location of components in the vehicle. It is a simple “picture” of how the circuits and components are connected together.
2. To quickly find a malfunction or trouble in the electrical system and repair it requires an understanding of how the system operates and a method of checking it out. “Troubleshooting” provides the “method” for checking out procedures and your technical manual troubleshooting tables and schematics provide the “operating procedures”.

## TROUBLESHOOTING

Troubleshooting is the systematic (step-by-step) isolation of a malfunction or trouble to the faulty component, harness connector/wire. It is a guide that helps develop a routine or “way” of finding troubles in any electrical system or circuit. As you become more familiar with this vehicle and gain experience, you will find ways to shorten these procedures and decrease down time. BEFORE you attempt to make any repairs or checks, do the following:

1. Find out how the system works under normal conditions and how to operate it.
2. Make sure the malfunction or trouble reported to you “really” exists. (“dead batteries” could end up as a “failure to start” because of a faulty neutral start switch or the transmission shift lever not fully engaged in park or neutral). Try to duplicate the trouble so you can be sure you are on the right track.
3. Check the Wiring Harness Troubleshooting (WP 0036 or WP 0037) for likely causes, then identify the circuit that is malfunctioning.
4. Study the electrical schematic to learn which components, harnesses, or wires could contribute to or cause the malfunction.

## NOTE

Remember, when tracing circuits on the electrical schematic, you should always start at the positive (+) side of the battery. Current will flow outward from that point through the circuits and return to the negative (-) side of the battery by way of ground wires and the vehicle frame.

5. Make necessary tests and checks to isolate circuits to component as outlined in the troubleshooting section of this technical manual.
6. Make repairs, if you are sure. If not, continue to isolate the malfunction, or ask for help from your foreman or supervisor.
7. After repairs, make sure everything has been re-connected and tightened.
8. Make operational checks to verify that the system/circuit is functioning properly again.

## TROUBLESHOOTING LOGIC TREE

Figure 1 is a troubleshooting logic tree. It is designed to help you develop a quick, logical way of approaching an electrical troubleshooting problem.

## ELECTRICAL SYMBOLS

Figures 2 and 3 show you the basic electrical symbols used with most schematics. They will help you read and understand the electrical circuits.



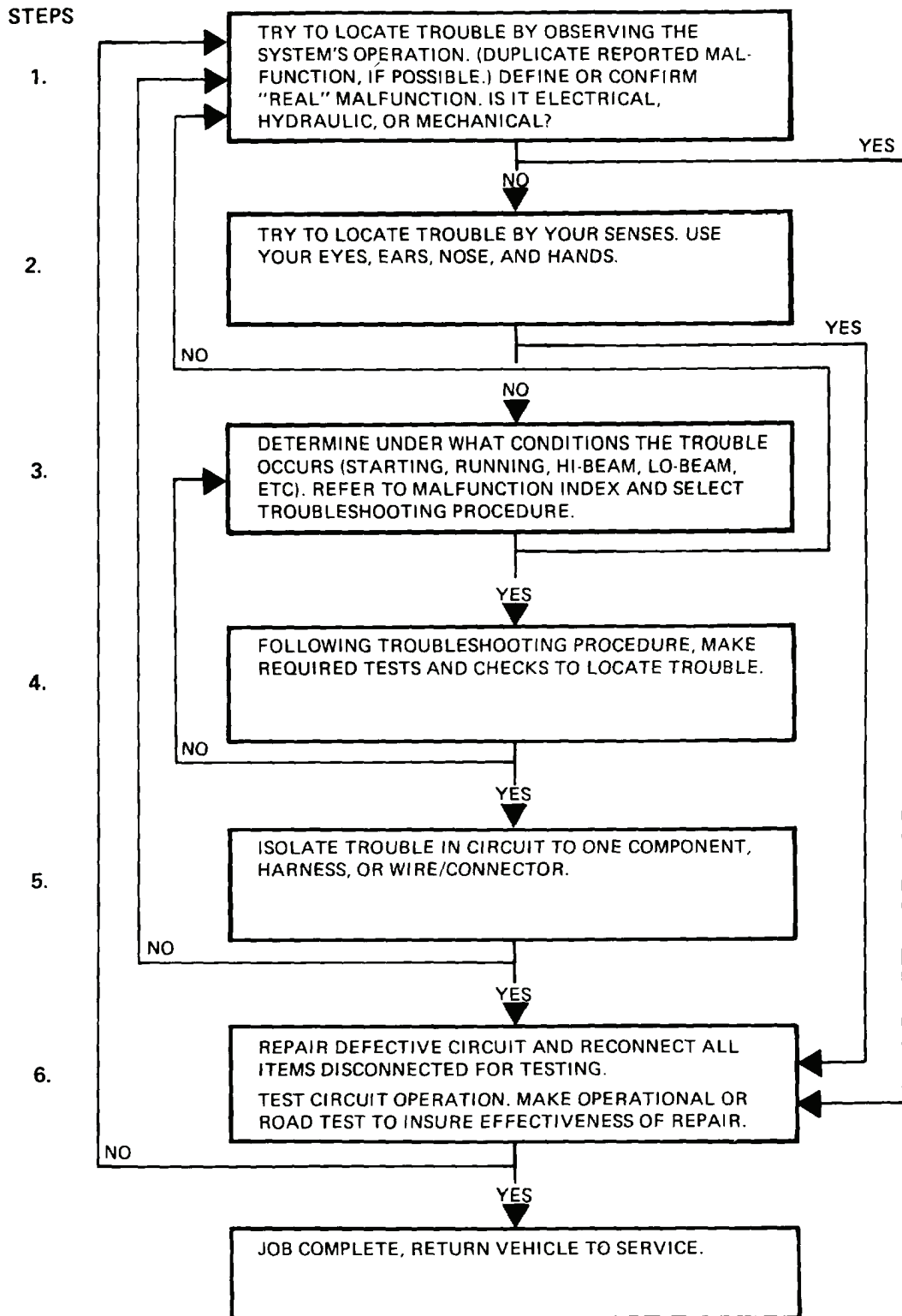







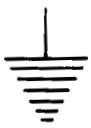

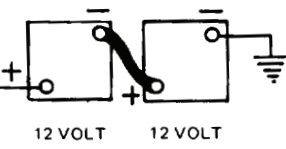
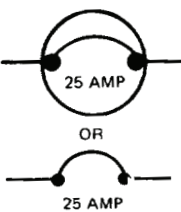
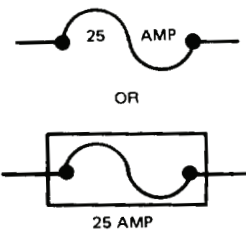
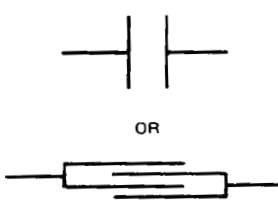
ELECTRICAL SYMBOLS - CONTINUED

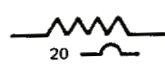

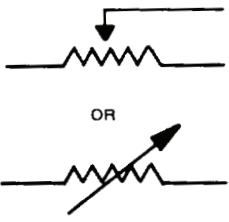
TA127509

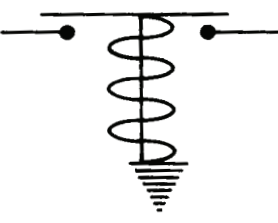
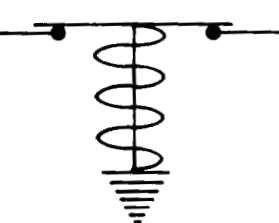
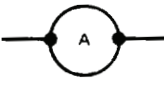
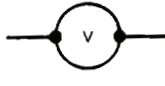
Figure 1. Troubleshooting Logic Tree.

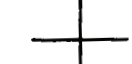
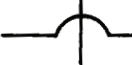
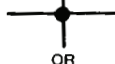
ELECTRICAL SYMBOLS - CONTINUED





<p>GROUND</p> 	<p>BATTERY (12 VOLT)</p> 	<p>BATTERIES IN SERIES HOOK-UP (24 VOLT CAPACITY)</p> 	<p>CIRCUIT BREAKER (AUTOMATIC RESET)</p> 
<p>FUSE</p> 	<p>CONDENSER</p> 	<p>OHMS:</p> 	<p>FIXED RESISTOR</p> 
<p>POTENTIOMETER</p> 	<p>VARIABLE RESISTOR</p> 	<p>DIODE/RECTIFIER (CURRENT FLOWS IN THE DIRECTION OF THE ARROW)</p> 	<p>RHEOSTAT</p> 
<p>NORMALLY OPEN RELAY (N.O.)</p> 	<p>NORMALLY CLOSED RELAY (N.C.)</p> 	<p>AMMETER</p>  <p>INDICATES TEST METER (NOT INSTRUMENT PANEL GAGE)</p>	<p>VOLT METER</p>  <p>INDICATOR TEST METER (NOT INSTRUMENT PANEL GAGE)</p>
<p>TYPICAL GAGE</p>  <p>TYPE/USE WILL BE LABELED ON WIRING DIAGRAM.</p>	<p>SLAVE OUTLET</p> 	<p>WIRES CROSS (NOT CONNECTED)</p>  <p>OR</p>  <p>NO CURRENT FLOW FROM ONE WIRE TO ANOTHER (NO PHYSICAL CONNECTION)</p>	<p>WIRES JOINED TOGETHER CONNECTED</p>  <p>OR</p>  <p>CURRENT FLOWS FROM ONE WIRE TO ANOTHER (PHYSICAL CONNECTION)</p>

TA127510.1

Figure 2. Electrical Symbols.

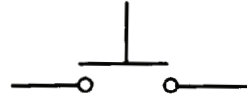
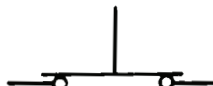
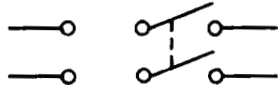
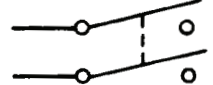
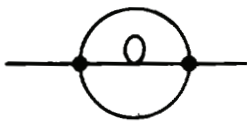
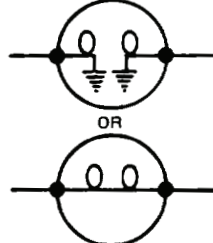
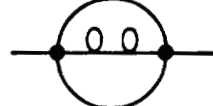
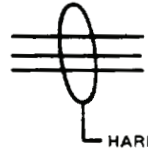
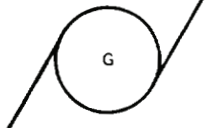
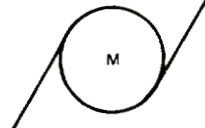
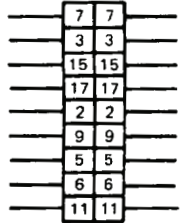

ELECTRICAL SYMBOLS - CONTINUED

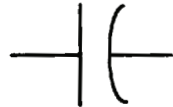
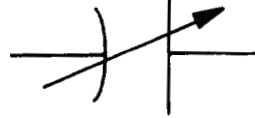
<p>SINGLE POLE SINGLE THROW (SPST)</p> 	<p>SINGLE POLE DOUBLE THROW (SPDT)</p> 	<p>NORMALLY OPEN MICRO SWITCH (N.O.) GENERALLY STENCILLED OR STAMPED ON SWITCH</p> 	<p>NORMALLY CLOSED MICRO SWITCH (N.C.) GENERALLY STENCILLED OR STAMPED ON SWITCH</p> 
<p>DOUBLE POLE DOUBLE THROW (DPDT)</p> 	<p>DOUBLE POLE SINGLE THROW (DPST)</p> 	<p>SINGLE FILAMENT LAMP</p> 	<p>DOUBLE FILAMENT LAMP</p>  <p>OR</p> 
<p>HARNESS ASSY.</p>  <p>HARNESS ASSY.</p>	<p>GENERATOR</p>  <p>G</p>	<p>MOTOR</p>  <p>M</p>	 <p>HARNESS/CABLE CONNECTOR</p>
 <p>DIRECTIONAL FLOW (CURRENT) ARROW</p>	 <p>CAPACITOR, FIXED</p>	 <p>CAPACITOR, VARIABLE</p>	

TA127510.2

Figure 3. Electrical Symbols (Con't).



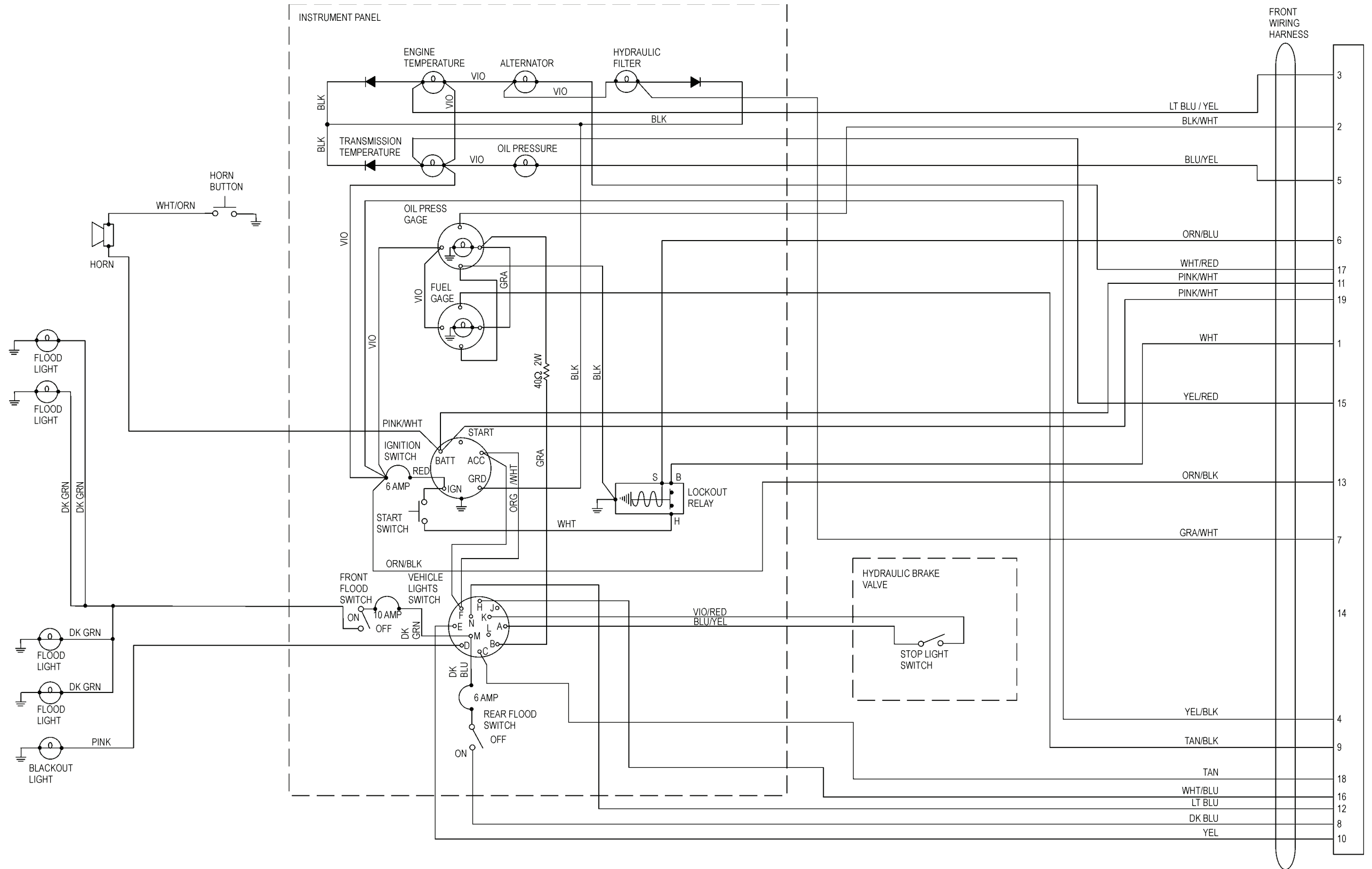

Figure 4. Front Wiring Harness (Model 207 and 4-390)  
0306-7/(0306-8 Blank)



ELECTRICAL DIAGRAM-CONTINUED

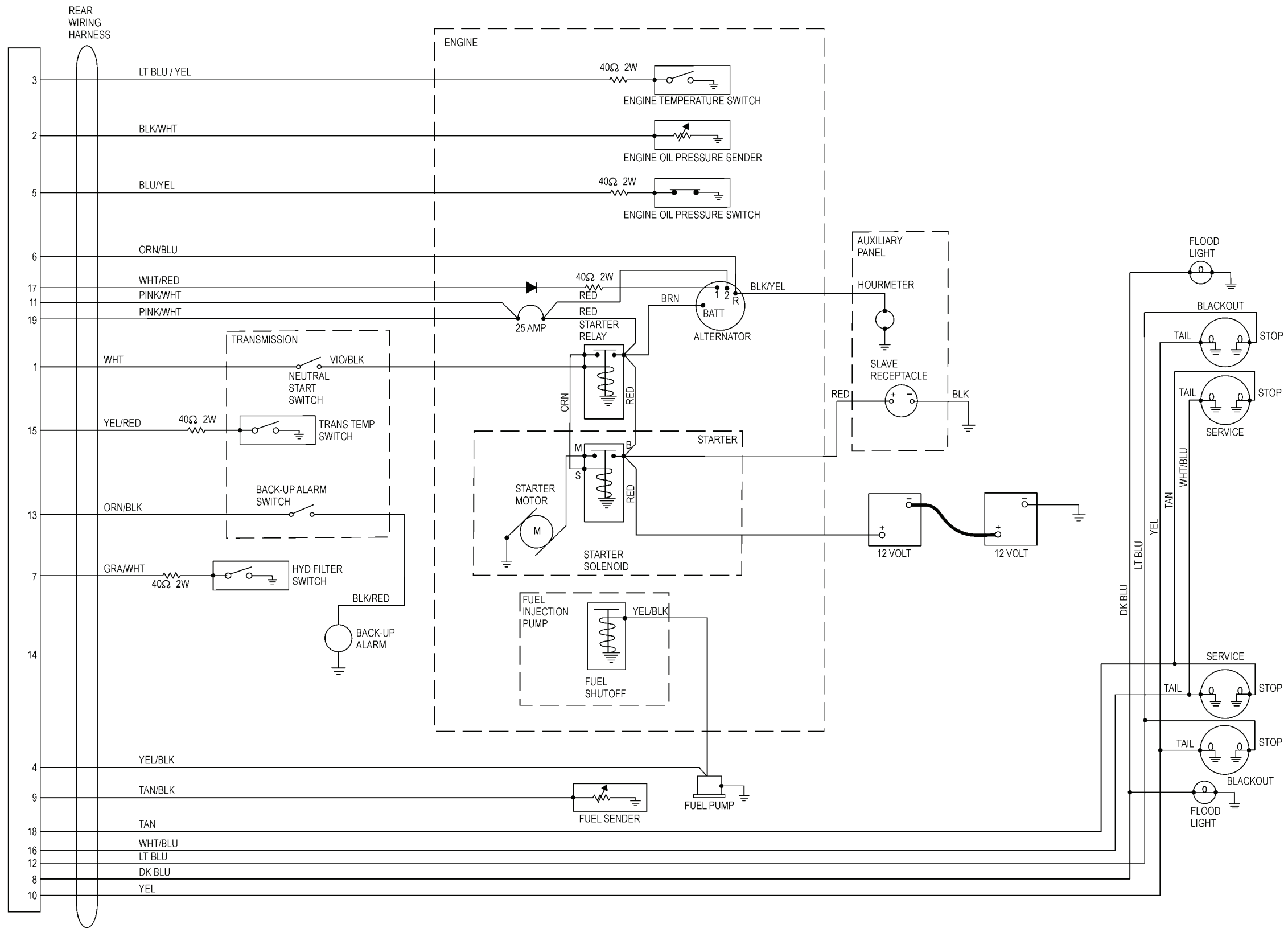
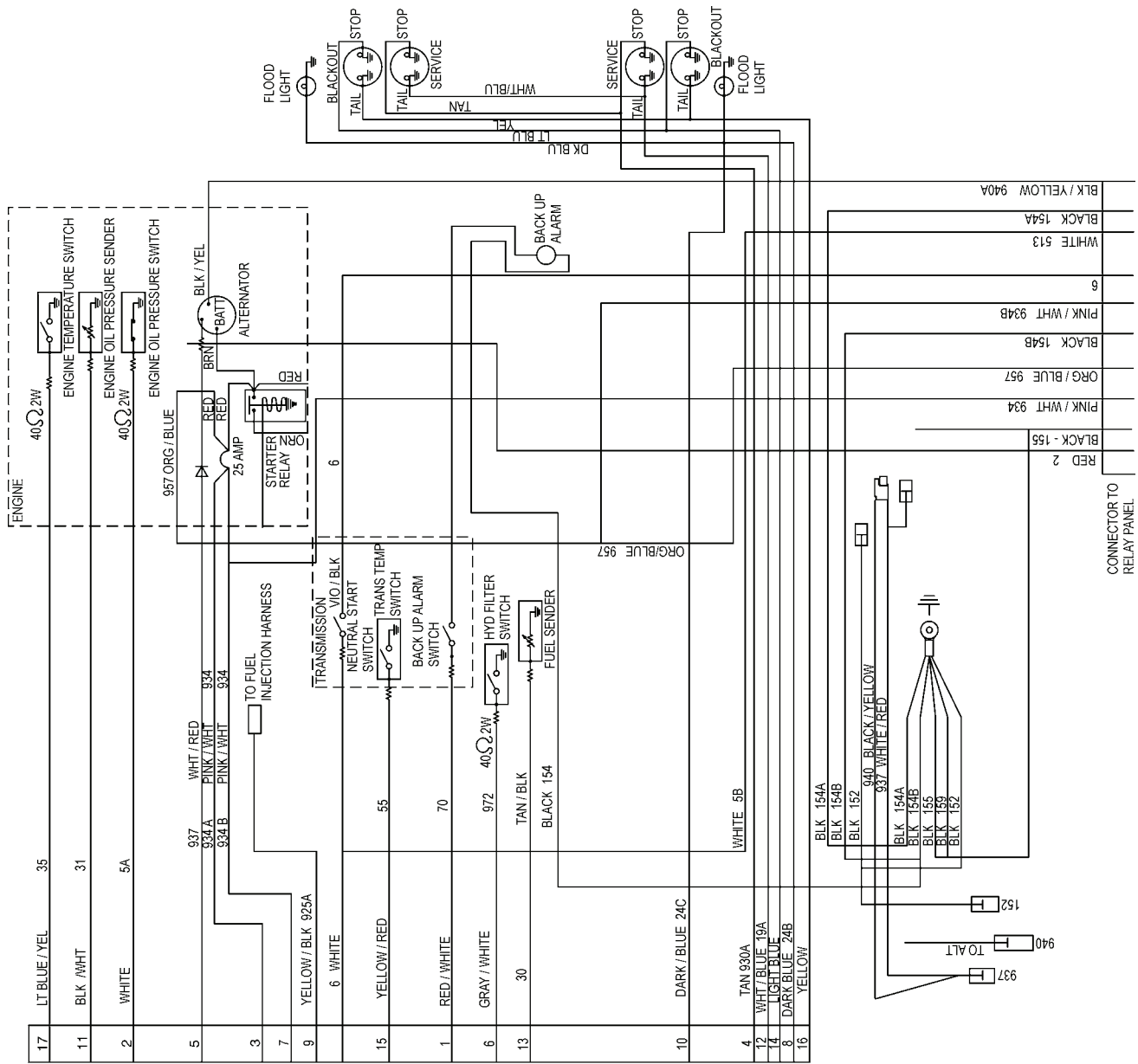

Figure 5. Rear Wiring Harness Model (207)  
0306-9/(0306-10 Blank)



ELECTRICAL DIAGRAMS - CONTINUED



CIRC NO.	COLOR	GA
5	WHITE	16
6	PURPLE - BLACK	16
9	YELLOW	14
18	LIGHT BLUE	14
19	WHITE - BLUE	14
24	DARK BLUE	14
30	TAN - BLACK	16
35	LT BLUE - YELLOW	16
55	YELLOW - RED	16
70	RED - WHITE	16
112	BLACK - RED	16
119	BROWN	8
152	BLACK - RED	16
154	BLACK - RED	16
159	BLACK - RED	16
925	YELLOW - BLACK	16
930	TAN - BLACK	16
934	PINK - WHITE	16
940	BLACK - YELLOW	16
957	ORANGE - BLUE	16
972	GRAY - WHITE	16
31	BLACK - WHITE	16
937	WHITE - RED	16
2	RED - WHITE	16
155	BLACK	16

CIRC NO.	PIN NO.
70	1
5A	2
934B	3
930A	4
937	5
972	6
934A	7
24B	8
925A	9
24C	10
51	11
19A	12
30	13
18A	14
55	15
9A	16
35	17
PLUG	18
PLUG	19

Figure 6. Rear Wiring Harness (Model 4-390).

444-0163

ELECTRICAL DIAGRAM - CONTINUED

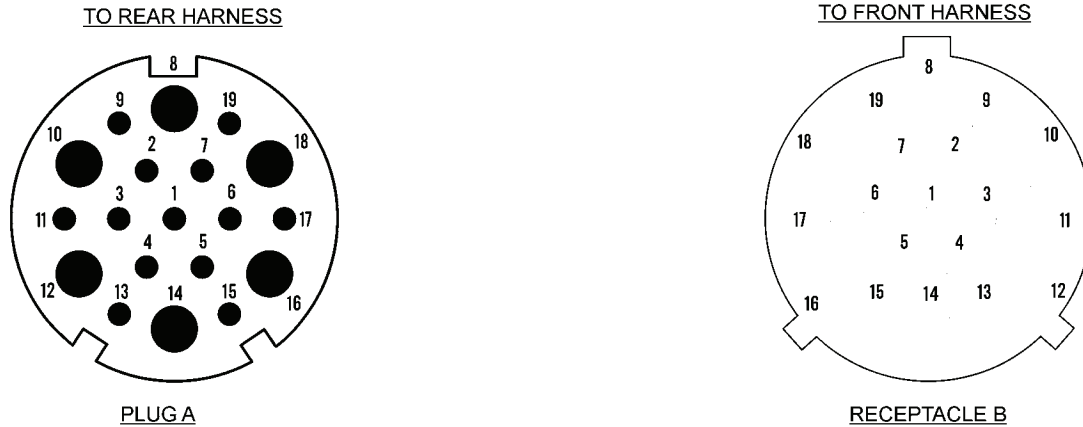

WIRE REF #	AWG	COLOR	LENGTH (INCH)	WIRE END 1			WIRE END 2		
				HOUSING	PIN	TERMINAL	TERMINAL	PIN	HOUSING
1	16	BLK	18	PLUG A	1	0461-201-1690 <sup>1</sup>	0461-201-1690 <sup>1</sup>	2	RECEP. B
2	16	BLK	18	PLUG A	2	0461-201-1690 <sup>1</sup>	0461-201-1690 <sup>1</sup>	11	RECEP. B
3	16	BLK	18	PLUG A	3	0461-201-1690 <sup>1</sup>	0461-201-1690 <sup>1</sup>	17	RECEP. B
4	16	BLK	18	PLUG A	4	0461-201-1690 <sup>1</sup>	0461-201-1690 <sup>1</sup>	9	RECEP. B
5	16	BLK	18	PLUG A	5	0461-201-1690 <sup>1</sup>	0461-201-1690 <sup>1</sup>	19	RECEP. B
6	16	BLK	18	N/A	-	19002-0025 <sup>2</sup>	+3/4" HSHRINK		
				PLUG A	6	PLUG 114017 <sup>1</sup>			
							PLUG 114017 <sup>1</sup>	5	RECEP. B
7	16	BLK	18	PLUG A	7	0461-201-1690 <sup>1</sup>	0461-201-1690 <sup>1</sup>	6	RECEP. B
8	14	BLK	118	PLUG A	-	112352 <sup>1</sup>	112349 <sup>1</sup>	8	RECEP. B
9	14	BLK	3	RECEP. B	10	112349 <sup>1</sup>	+3/4" HSHRINK		
10	16	BLK	18	PLUG A	9	0461-201-1690 <sup>1</sup>	0461-201-1690 <sup>1</sup>	13	RECEP. B
11	14	BLK	18	PLUG A	10	112352 <sup>1</sup>	112349 <sup>1</sup>	16	RECEP. B
14	16	BLK	18	PLUG A	11	0461-201-1690 <sup>1</sup>	0461-201-1690 <sup>1</sup>	11	RECEP. B
15	14	BLK	18	PLUG A	12	112352 <sup>1</sup>	112349 <sup>1</sup>	12	RECEP. B
16	16	BLK	18	PLUG A	13	0461-201-1690 <sup>1</sup>	0461-201-1690 <sup>1</sup>	1	RECEP. B
17	16	BLK	18	N/A	-	19002-0025 <sup>2</sup>	+3/4" HSHRINK		
				PLUG A	14	PLUG 114017 <sup>1</sup>			
18	16	BLK	18	PLUG A	15	112352 <sup>1</sup>	0461-201-1690 <sup>1</sup>	15	RECEP. B
19	14	BLK	18	PLUG A	16	112352 <sup>1</sup>	112349 <sup>1</sup>	16	RECEP. B
20	16	BLK	18	PLUG A	17	0461-201-1690 <sup>1</sup>	0461-201-1690 <sup>1</sup>	17	RECEP. B
21	16	BLK	18	N/A	-	19002-0025 <sup>2</sup>	+3/4" HSHRINK		
22	16	BLK	18	PLUG A	18	112352 <sup>1</sup>	0461-201-1690 <sup>1</sup>	18	RECEP. B
23	16	BLK	18	PLUG A	19	0461-201-1690 <sup>1</sup>	0461-201-1690 <sup>1</sup>	19	RECEP. B

929

940

60

- OIL PRESSURE SWITCH
- DIODE
- HOUR METER

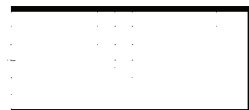

Figure 7. Adapter Wiring Harness (Model 4-390).



ELECTRICAL DIAGRAM - CONTINUED

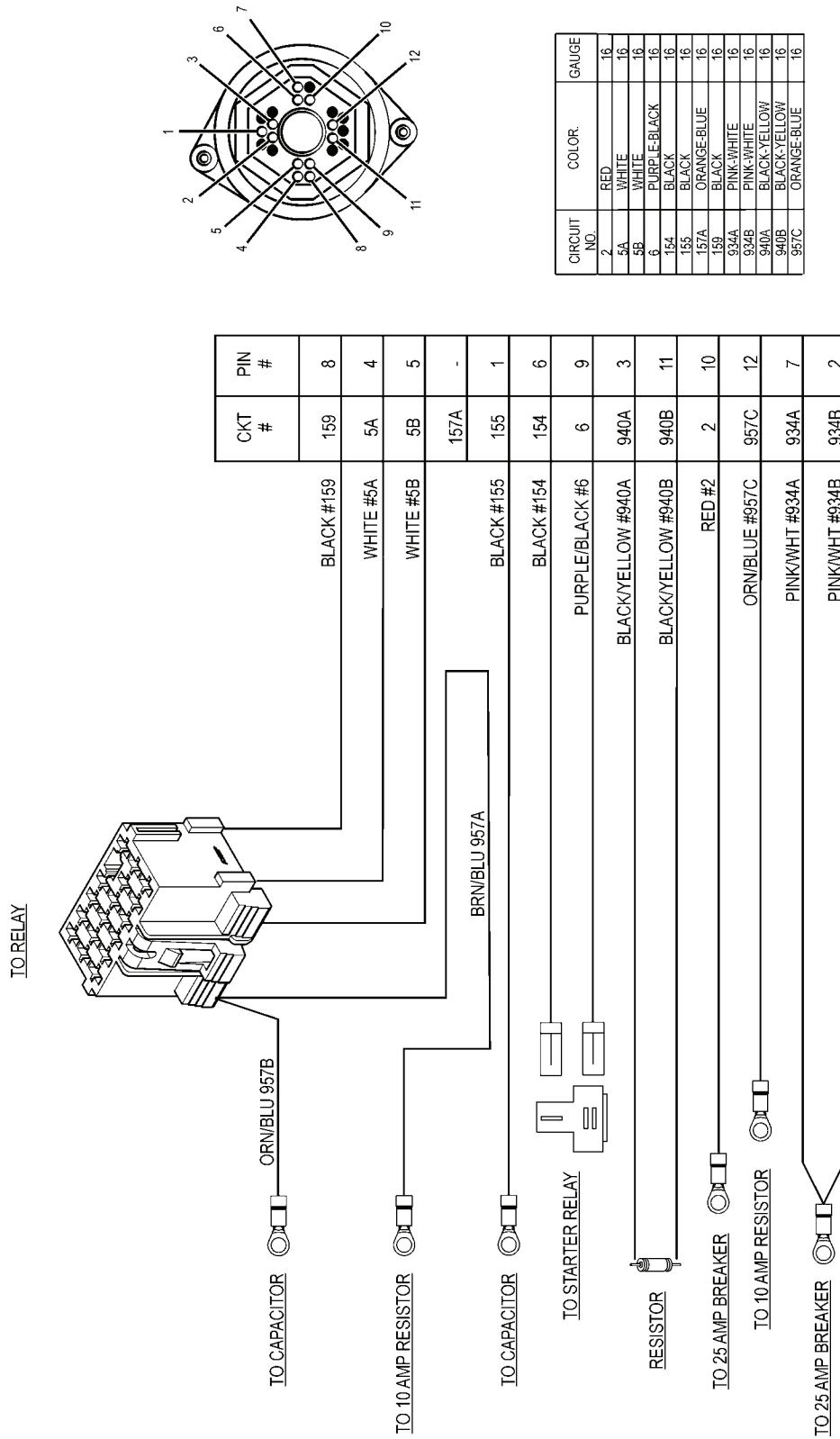

Figure 8. Relay Panel Wiring Harness (Model 4-390).

444-0165

ELECTRICAL DIAGRAM - CONTINUED

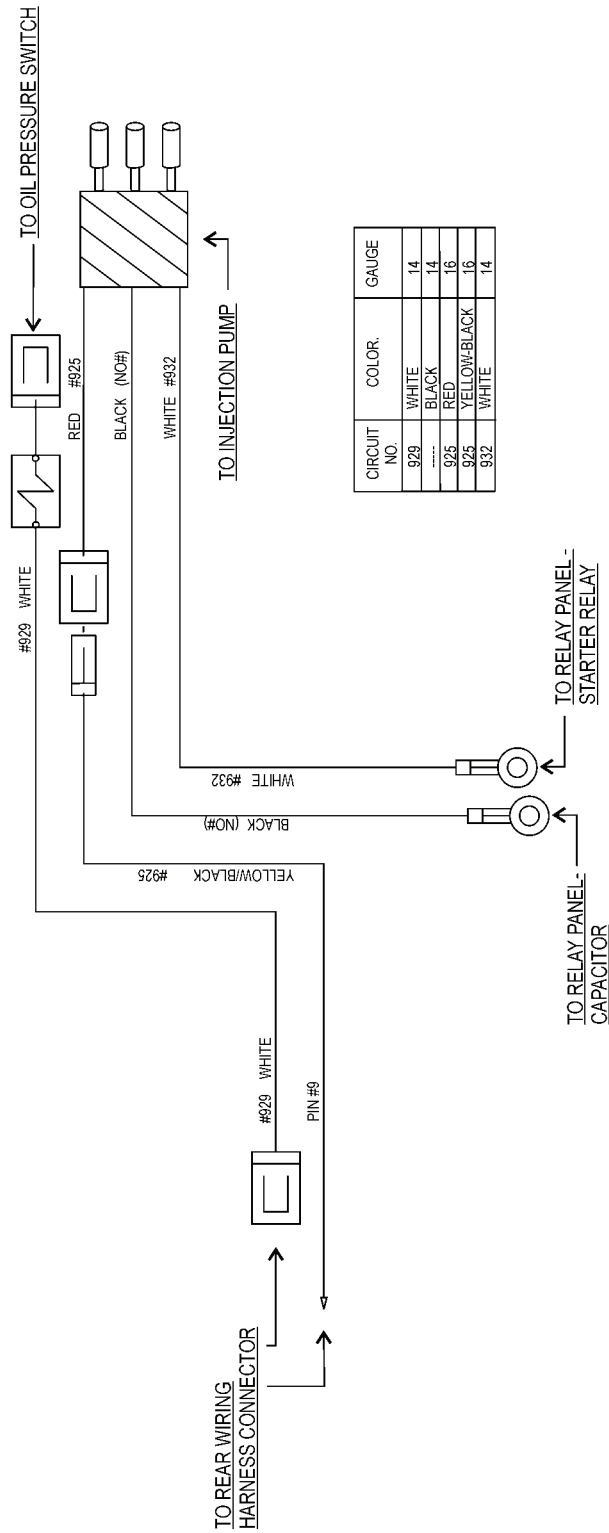
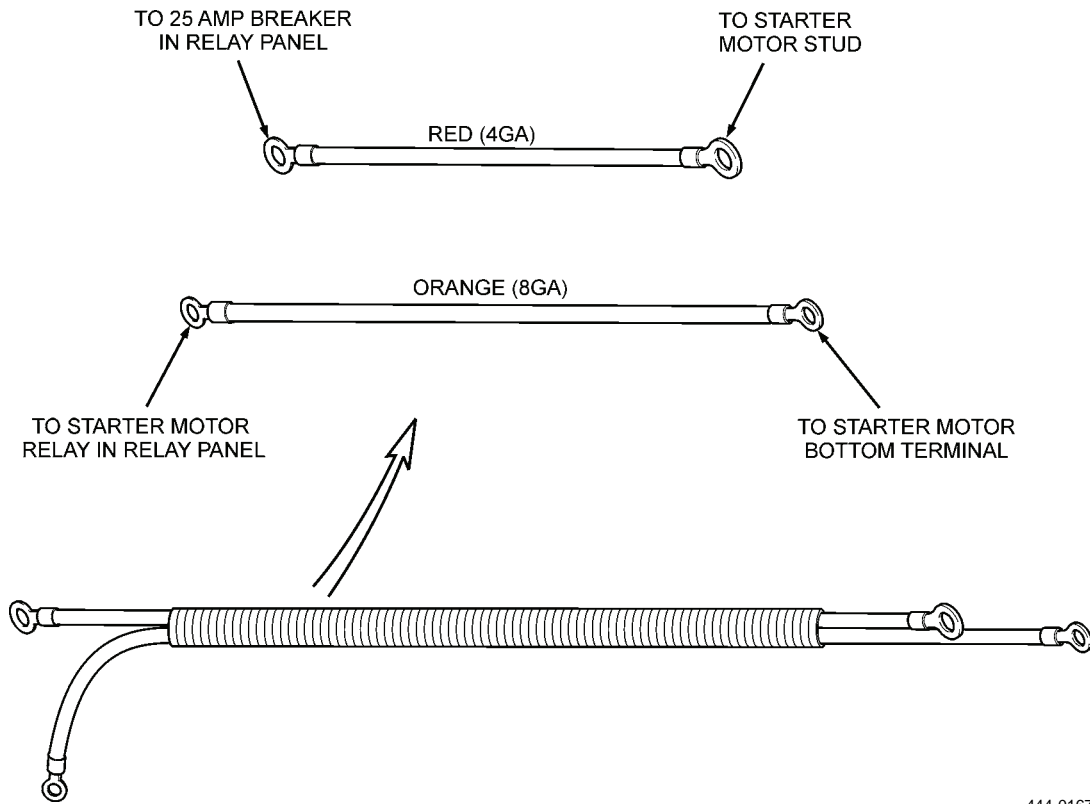

Figure 9. Fuel Injector Wiring Harness (Model 4-390).

**ELECTRICAL DIAGRAM - CONTINUED**



444-0167

**Figure 10. Cable Wiring Harness (Model 4-390).**

HYDRAULIC DIAGRAM

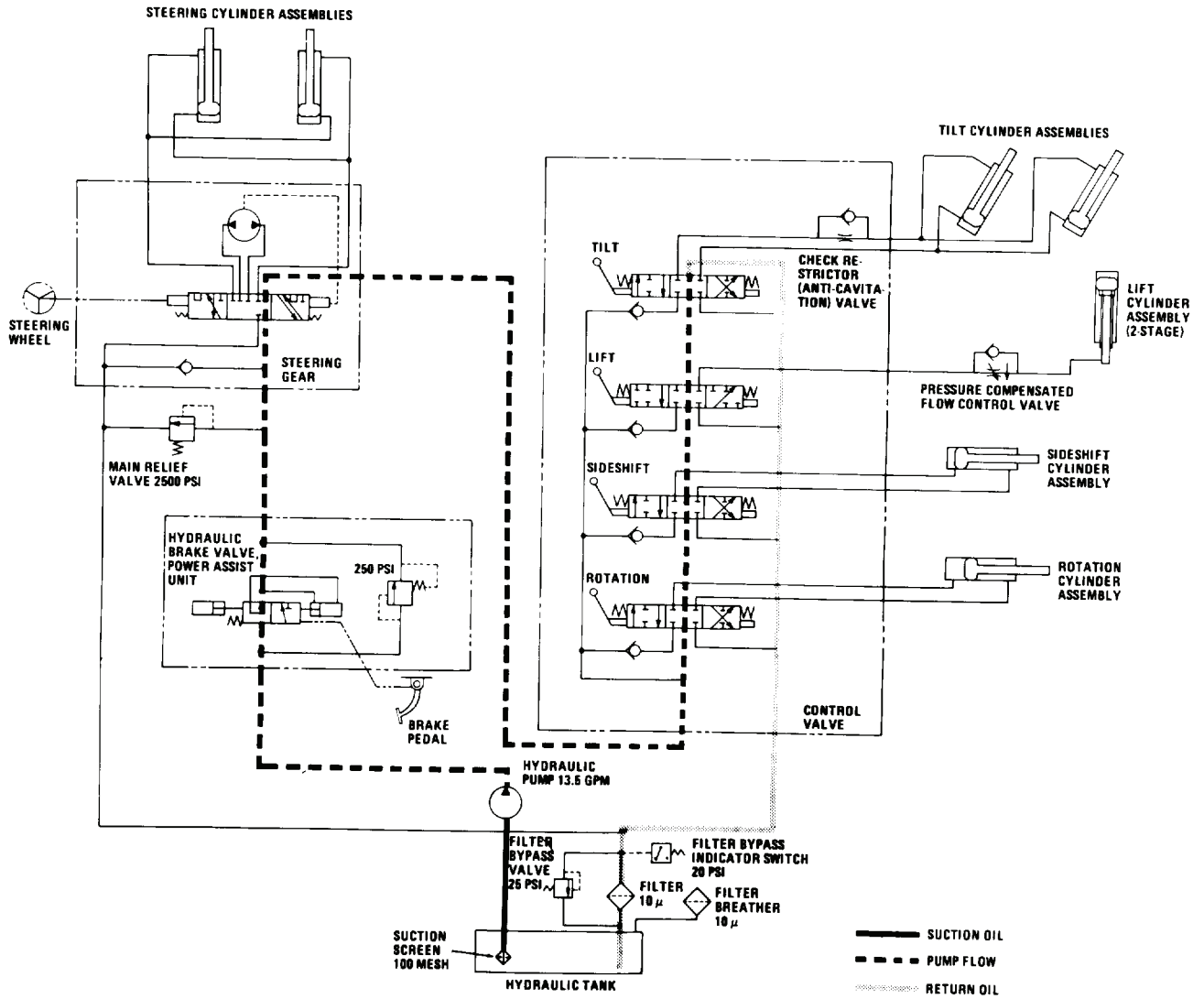

TA127512

Figure 11. Hydraulic Diagram (Controls in Neutral Position).

HYDRAULIC DIAGRAM - CONTINUED

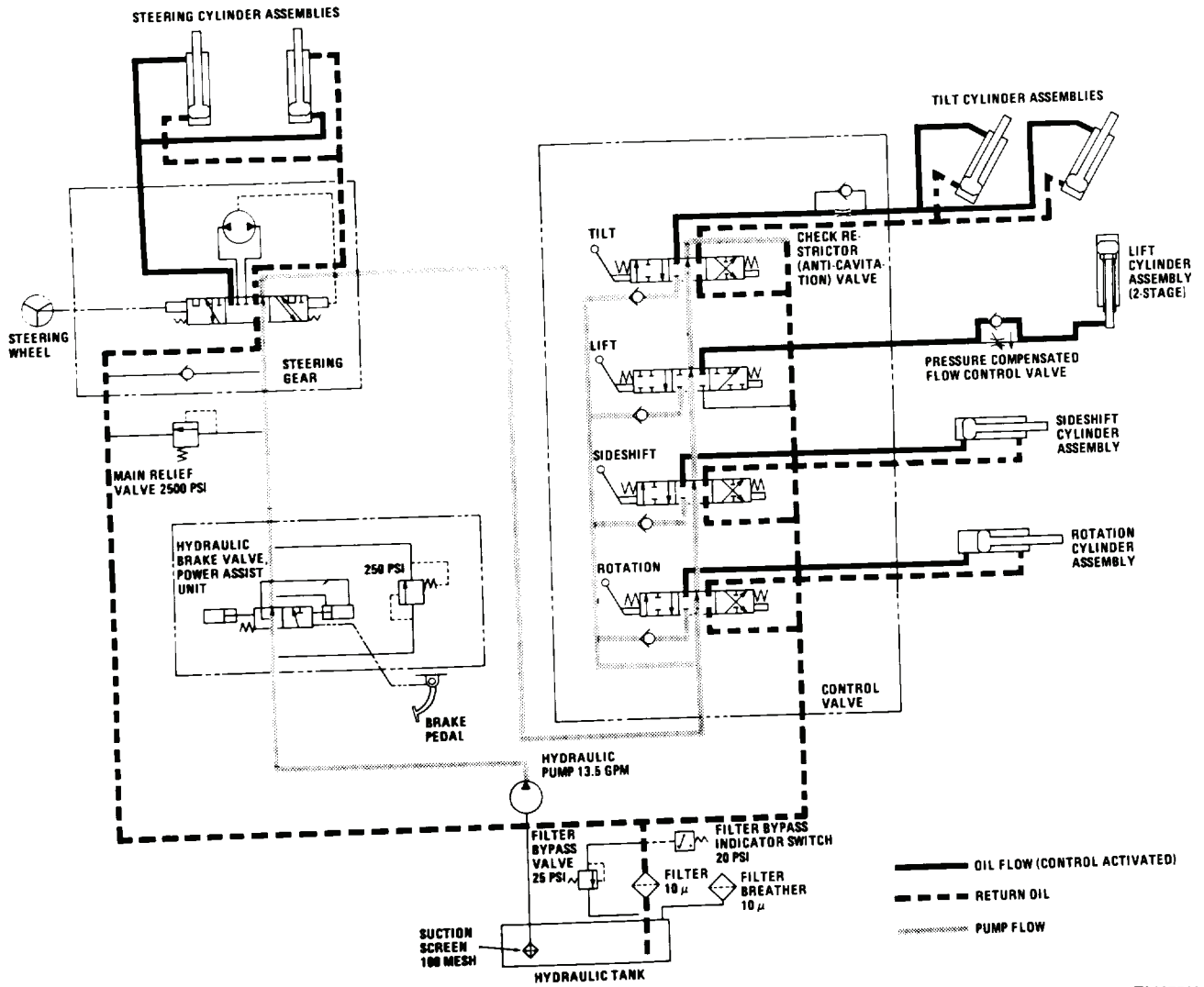

TA127513

Figure 12. Hydraulic Diagram (Con't) (Controls Activated).

END OF WORK PACKAGE



**CHAPTER 7**  
**SUPPORTING INFORMATION**





---

## SUPPORTING INFORMATION

### REFERENCES

---

#### PUBLICATION INDEXES AND GENERAL REFERENCES

Indexes should be consulted frequently for latest changes or revisions of references given in this manual and for new publications relating to material covered in this publication.

*Military Publication Indexes.*

Authorized Abbreviations and Brevity Codes . . . . . AR 310-50  
 Consolidated Index of Army Publications and Blank Forms . . . . . DA PAM 25-30

*General References.*

Dictionary of United States Army Terms . . . . . AR 310-25  
 Operational Terms and Symbols . . . . . FM 101-5-1  
 Training in Units . . . . . FM 25-3

#### OTHER PUBLICATIONS

The following publications contain information pertinent to the major item material and associated equipment

Camouflage.

Camouflage . . . . . FM 5-20

Decontamination.

NBC Decontamination . . . . . FM 3-5

General.

Accident Reporting and Records . . . . . AR 385-40  
 Basic Cold Weather Manual . . . . . FM 31-70  
 Cooling Systems: Tactical Vehicles . . . . . TM 750-254  
 Manual for Wheel Vehicle Driver . . . . . FM 21-305  
 Driver Selection and Training (Wheeled Vehicles) . . . . . FM 55-30  
 Mountain Operations . . . . . FM 90-6  
 Northern Operations . . . . . FM 31-71  
 Operation and Maintenance of Ordnance Materiel in Cold Weather (0°F to -65°F) . . . . . FM 9-207  
 Principles of Automotive Vehicles . . . . . TM 9-8000  
 Prevention of Motor Vehicle Accidents . . . . . AR 385-55  
 Procedures for Destruction of Tank Automotive Equipment to Prevent Enemy Use . . . . . TM 750-244-6

Maintenance and Repair.

Organizational, Direct Support and General Support Care, Maintenance, and Repair of Pneumatic Tires and Inner Tubes . . . . . TM 9-2610-200-24  
 Description, Use, Bonding Techniques, and Properties of Adhesives . . . . . TB ORD 1032  
 Inspection, Care, and Maintenance of Antifriction Bearings . . . . . TM 9-214  
 Materials Used for Cleaning, Preserving, Abrading, and Cementing Ordnance Materiel and Related Materials Including Chemicals . . . . . TM 9-247  
 Metal Body Repair and Related Operations . . . . . FM 43-2  
 Operation and Organizational, Maintenance Manual for Lead-Acid Storage Batteries . . . . . TM 9-6140-220-14

**OTHER PUBLICATIONS - CONTINUED**

Army Material Maintenance Policies . . . . . AR 750-1

Use of Antifreeze Solutions and Cleaning Compounds in Engine Cooling System . . . . . TB 750-651

Welding Theory and Application . . . . . TM 9-237

Color, Marking, and Camouflage Painting of Military Vehicles Construction  
Equipment, and Materials Handling Equipment . . . . . TB 43-0209

Shipment and Limited Storage.

Administrative Storage of Equipment . . . . . TM 740-90-1

Packing of Army Materiel for Shipment and Storage . . . . . AR 746-1

The Army Maintenance Management System (TAMMS) Users Manual . . . . . DA PAM 750-8

Vehicle.

Truck, Forklift, DED, Pneumatic Tire, Articulated Frame Steer, 4,000 lb Capacity,  
Rough Terrain, Army Model MHE 237 (J. I. Case Model M4K) . . . . . LO 10-3930-638-12

**END OF WORK PACKAGE**

---

## SUPPORTING INFORMATION

### MAINTENANCE ALLOCATION CHART (MAC) INTRODUCTION

---

#### THE ARMY MAINTENANCE SYSTEM

1. This introduction provides a general explanation of all maintenance and repair functions authorized at the two maintenance levels.
2. The Maintenance Allocation Chart (MAC) designates overall responsibility for the performance of maintenance functions on the identified component or assembly. The implementation of the maintenance functions upon the component or assembly will be consistent with the assigned maintenance functions.
3. The tools and test equipment requirements (immediately following the MAC) list the tools and test equipment (both special tools and common tool sets) required for each maintenance function as referenced from the MAC.
4. The remarks (immediately following the tools and test equipment requirements) contain supplemental instructions and explanatory notes for a particular maintenance function.

#### MAINTENANCE FUNCTIONS

Maintenance functions are limited to and defined as follows:

1. **Inspect.** To determine the serviceability of an item by comparing its physical, mechanical, and/or electrical characteristics with established standards through examination (e.g., by sight, sound, or feel).
2. **Test.** To verify serviceability by measuring the mechanical, pneumatic, hydraulic, or electrical characteristics of an item and comparing those characteristics with prescribed standards on a scheduled basis, i.e., load testing of lift devices and hydrostatic testing of pressure hoses.
3. **Service.** Operations required periodically to keep an item in proper operating condition; e.g., to clean (includes decontaminate, when required), preserve, drain, paint, or replenish fuel, lubricants, chemical fluids, or gases.
4. **Adjust.** To maintain or regulate, within prescribed limits, by bringing into proper position, or by setting the operating characteristics to specified parameters.
5. **Align.** To adjust specified variable elements of an item to bring about optimum or desired performance.
6. **Calibrate.** To determine and cause corrections to be made or to be adjusted on instruments of test, measuring, and diagnostic equipment used in precision measurement. Calibration consists of comparisons of two instruments, one of which is a certified standard of known accuracy, to detect and adjust any discrepancy in the accuracy of the instrument being compared.
7. **Remove/Install.** To remove and install the same item when required to perform service or other maintenance functions. Installation may be the act of emplacing or seating a spare, repair part, or module (component or assembly) into position in a manner to allow the proper functioning of an equipment or system.
8. **Replace.** To remove an unserviceable item and install a serviceable counterpart in its place. Replacement is authorized by the MAC and the assigned maintenance level is shown as the third position code of the Source, Maintenance, and Recoverability (SMR) code.
9. **Repair.** Repair is the application of maintenance services, including fault location/troubleshooting, removal/installation, disassembly/assembly procedures, and maintenance actions to identify troubles and restore serviceability to an item by correcting specific damage, fault, malfunction, or failure in a part, subassembly, module (component or assembly), end item, or system.

**MAINTENANCE FUNCTIONS - CONTINUED****NOTE**

The following definitions are applicable to the “repair” maintenance function:

- Services - Inspecting, testing, service, adjustment, alignment, calibration, and/or replacement.
  - Fault location/troubleshooting - The process of investigating and detecting the cause of equipment malfunctioning; the act of isolating a fault within a system or Unit Under Test (UUT).
  - Disassembly/assembly - The step-by-step breakdown (taking apart) of a spare/functional group coded item to the level of its least component, assigned a SMR code for the level of maintenance under consideration (i.e., identified as maintenance significant).
  - Actions - Welding, grinding, riveting, straightening, facing, machining, and/or resurfacing.
10. **Overhaul.** That maintenance effort (service/action) prescribed to restore an item to a completely serviceable/operational condition as required by maintenance standards in appropriate technical publications. Overhaul is normally the highest degree of maintenance performed by the Army. Overhaul does not normally return an item to like new condition.
11. **Rebuild.** Consists of those services/actions necessary for the restoration of unserviceable equipment to a like new condition in accordance with original manufacturing standards. Rebuild is the highest degree of materiel maintenance applied to Army equipment. The rebuild operation includes the act of returning to zero those age measurements (hours/miles, etc.) considered in classifying Army equipment/components.

**EXPLANATION OF COLUMNS IN THE MAC, TABLE 1**

1. **Column (1) - Group Number.** Column (1) lists Group numbers, the purpose of which is to identify maintenance significant components, assemblies, subassemblies, and modules with the Next Higher Assembly (NHA).
2. **Column (2) - Component/Assembly.** Column (2) contains the item names of components, assemblies, subassemblies, and modules for which maintenance is authorized.
3. **Column (3) - Maintenance Function.** Column (3) lists the functions to be performed on the item listed in Column (2). (For a detailed explanation of these functions refer to “Maintenance Functions” outlined above).
4. **Column (4) - Maintenance Level.** Column (4) specifies each level of maintenance authorized to perform each function listed in column (3), by indicating work time required (expressed as manhours in whole hours or decimals) in the appropriate subcolumn. This work time figure represents the active time required to perform that maintenance function at the indicated level of maintenance. If the number or complexity of the tasks within the listed maintenance function varies at different maintenance levels, appropriate work time figures are to be shown for each level. The work time figure represents the average time required to restore an item (assembly, subassembly, component, module, end item, or system) to a serviceable condition under typical field operating conditions. This time includes preparation time (including any necessary disassembly/assembly time), troubleshooting/fault location time, and quality assurance time in addition to the time required to perform the specific tasks identified for the maintenance functions authorized in the MAC. The symbol designations for the various maintenance levels are as follows:

Field:

C - Operator/Crew Maintenance  
O - Unit Maintenance  
F - Direct Support Maintenance

Sustainment:

H - General Support Maintenance  
D - Depot Maintenance

---

**EXPLANATION OF COLUMNS IN THE MAC, TABLE 1 - CONTINUED****NOTE**

The "L" maintenance level is not included in column (4) of the MAC. Functions to this level of maintenance are identified by a work time figure in the "H" column of column (4), and an associated reference code is used in the REMARKS CODE column (6). This code is keyed to the remarks, and the SRA complete repair application is explained there.

5. **Column (5) - Tools and Equipment Reference Code.** Column (5) specifies, by code, common tool sets (not individual tools), common Test, Measurement, and Diagnostic Equipment (TMDE), special tools, special TMDE, and special support equipment required to perform the designated function. Codes are keyed to the entries in the tools and test equipment (Table 2).
6. **Column (6) - Remarks Code.** When applicable, this column contains a letter code, in alphabetical order, which is keyed to the remarks table entries (Table 3).

**EXPLANATION OF COLUMNS IN THE TOOLS AND TEST EQUIPMENT REQUIREMENTS, TABLE 2**

1. **Column (1) - Tool or Test Equipment Reference Code.** The tool and test equipment reference code correlates with a code used in column (5) of the MAC.
2. **Column (2) - Maintenance Level.** The lowest level of maintenance authorized to use the tool or test equipment.
3. **Column (3) - Nomenclature.** Name or identification of the tool or test equipment.
4. **Column (4) - National Stock Number (NSN).** The NSN of the tool or test equipment.
5. **Column (5) - Tool Number.** The manufacturer's part number, model number, or type number.

**EXPLANATION OF COLUMNS IN THE REMARKS, TABLE 3**

1. **Column (1) - Remarks Code.** The code recorded in column (6) of the MAC.
2. **Column (2) - Remarks.** This column lists information pertinent to the maintenance function being performed as indicated in the MAC.

**END OF WORK PACKAGE**



**SUPPORTING INFORMATION**  
**MAINTENANCE ALLOCATION CHART (MAC)**

**Table 1. MAC for the Model MHE 237 Forklift Truck.**

Group Number	Component/ Assembly	Maintenance Function	Maintenance Level					Tools/ Equipment Ref Code	Remarks Code	
			Field			Sustainment				
			Unit		DS	GS	Depot			
			C	O	F	H	D			
01 0100	ENGINE Engine Assembly Engine Assembly	Inspect	0.1							
		Service	0.5	1.5				1-3		
		Adjust			2.0			3,4		
		Replace			8.0			3,4		
		Repair				2.0		3,4,11,12		
		Overhaul					50.0			
		Engine Mounts	Inspect			0.1				
		Replace			2.0			3,4		
		0101	Crankcase, Block Cylinder Head Cylinder Block	Inspect			0.1			
				Release				50.0		3,4
Repair						8.0		3,4,11,12		
Cylinder Head Assembly	Inspect					0.1				
Replace					1.5			3,4		
Repair					4.0			3,4,11,12		
0102	Crankshaft Crankshaft	Overhaul				4.0				
		Inspect				0.3		3,4		
		Replace				20.0		3,4		
		Repair				8.0		3,4,11,12		
		Bearings, Main	Inspect				1.0		3,4	
0103	Flywheel Assembly Flywheel	Replace				6.0		3,4		
		Inspect		1.0						
		Replace				8.0		3,4		
		Repair				2.5		3,4,11,12		

Table 1. MAC for the Model MHE 237 Forklift Truck - Continued.

Group Number	Component/ Assembly	Maintenance Function	Maintenance Level					Tools/ Equipment Ref Code	Remarks Code
			Field		Sustainment				
			Unit		DS	GS	Depot		
			C	O	F	H	D		
<b>01</b>	<b>ENGINE - CONTINUED</b>								
0104	Pistons and Connecting Rods								
	Piston	Replace				16.0	3,4		
		Repair				3.0	3,4,11,12		
	Connecting Rod	Replace				16.0	3,4		
		Repair				3.0	3,4,11,12		
	Bearings, Connecting Rod	Inspect				1.0	3,4		
		Replace				2.0	3,4		
0105	Valves, Camshaft, and Timing System								
	Rocker Arm Assembly	Adjust			1.0		3,4		
		Replace			2.0		3,4		
		Repair			2.0		3,4,11,12		
	Valves	Replace				8.0	3,4		
		Repair				8.0	3,4,11,12		
	Camshaft	Replace				2.0	3,4		
	Timing Gears	Replace				2.0	3,4		
0106	Engine Lubrication System								
	Oil Pan	Replace			3.0		3,4		
		Repair			1.0		3,4		
	Engine Oil Pump	Replace				6.0	3,4		
		Repair				1.0	3,4		
	Oil Filter	Replace		0.5			1-3		
0108	Manifolds								
	Manifolds, Intake and Exhaust	Inspect	0.1						
		Replace		0.7			1-3		
	Spark Arrester	Replace		0.5			1-3		



**Table 1. MAC for the Model MHE 237 Forklift Truck - Continued.**

Group Number	Component/ Assembly	Maintenance Function	Maintenance Level					Tools/ Equipment Ref Code	Remarks Code
			Field			Sustainment			
			Unit		DS	GS	Depot		
			C	O	F	H	D		
<b>03</b>	<b>FUEL SYSTEM</b>								
0301	Fuel Injector								
	Fuel Injector	Test				1.0	9		
		Replace			2.5		1,4,7,8		
		Repair				1.5	3,4,7,8		
	Fuel Injector Lines	Inspect	0.2						
		Replace			1.0		1,4,7,8		
0302	Fuel Pump and Lines								
	Fuel Injection Pump	Test		0.5					
		Replace			1.0		1,4,7,8		
		Repair				2.0	1,2,4,7,8		
	Fuel Lines	Inspect	0.5						
		Replace		1.0			1,2		
	Electric Fuel Pump	Test		0.5					
		Replace		1.0			1-3		
0304	Air Cleaner								
	Air Cleaner	Service		0.5			1,2		
		Replace		0.5			1,2		
0306	Tank, Lines, Fittings								
	Fuel Tank	Inspect	0.1						
		Service		0.3			1,2		
0309	Fuel Filter								
	Fuel Filter	Service		0.5			1,2		
		Replace		0.7			1,2		
	Fuel Strainer	Inspect	0.1						
		Service		1.0			1,2		
		Replace		1.5			1,2		
0311	Engine Starting Aids								
	Cold Start Kit	Inspect	0.1						
		Replace		1.0			1-3		
		Repair		0.5			1-3		

Table 1. MAC for the Model MHE 237 Forklift Truck - Continued.

Group Number	Component/ Assembly	Maintenance Function	Maintenance Level					Tools/ Equipment Ref Code	Remarks Code
			Field		Sustainment				
			Unit		DS	GS	Depot		
			C	O	F	H	D		
<b>03</b>	<b>FUEL SYSTEM - CONTINUED</b>								
0312	Accelerator, Throttle Control								
	Throttle Control	Inspect	0.1						
		Adjust		0.5			1-3		
		Replace		0.5			1-3		
<b>04</b>	<b>EXHAUST SYSTEM</b>								
0401	Muffler and Pipe								
	Muffler and Pipe	Inspect	0.1						
		Replace		1.0			1-3		
<b>05</b>	<b>COOLING SYSTEM</b>								
0501	Radiator								
	Radiator Assembly	Inspect	0.1						
		Service		0.2			1-3		
		Replace		2.0			1-3		
		Repair			3.0		3,4		
0503	Water Manifold, Headers, Gasket								
	Thermostat and Housing	Test		0.1			1-3		
		Replace		0.5			1-3		
	Hose, Lines, and Fittings	Inspect	0.1						
		Replace		0.3			1-3		
0504	Water Pump								
	Pump Assembly	Inspect	0.1						
		Replace		0.5			1-3		
	Belt Drive	Inspect	0.1						
		Adjust		0.3			1-3		
		Replace		0.5			1-3		

Table 1. MAC for the Model MHE 237 Forklift Truck - Continued.

Group Number	Component/ Assembly	Maintenance Function	Maintenance Level					Tools/ Equipment Ref Code	Remarks Code
			Field		Sustainment				
			Unit		DS	GS	Depot		
			C	O	F	H	D		
<b>06</b>	<b>ELECTRICAL SYSTEM</b>								
0601	Alternator	Test							
		Inspect	0.1						
		Test		0.5				1-3	
		Replace		1.5				1-3	
		Repair			1.0			1-3,7,8	
	Alternator Connections	Inspect	0.1						
		Test		0.5				1-3	
		Replace		1.5				1-3	
		Repair			1.0			3,4,7,8	
		Inspect	0.1						
0603	Drive Belt	Inspect	0.1						
		Adjust		0.3					
		Replace		0.5					
		Starting Motor	Inspect		0.2				
		Starter	Test		0.5			1-3	
	Solenoid	Replace		0.5				1-3	
		Repair			1.0			1,7,8	
		Inspect		0.1					
		Test		0.5				1-3	
		Repair			0.5			3,4,7,8	
0607	Instrument or Engine Control Panel	Inspect	0.1						
		Repair		0.5				1-3	
	Hourmeter	Inspect	0.1						
		Replace		0.5				1-3	

Table 1. MAC for the Model MHE 237 Forklift Truck - Continued.

Group Number	Component/ Assembly	Maintenance Function	Maintenance Level					Tools/ Equipment Ref Code	Remarks Code
			Field		Sustainment				
			Unit		DS	GS	Depot		
			C	O	F	H	D		
<b>06</b>	<b>ELECTRICAL SYSTEM - CONTINUED</b>								
0609	Lights								
	Front Floodlights	Inspect	0.1						
		Test		0.1			1,2		
		Replace		0.5			1-3		
	Blackout Lights	Inspect	0.1						
		Test		0.1			1,2		
		Replace		0.5			1-3		
	Taillights	Inspect	0.1						
		Test		0.1			1,2		
		Replace		0.5			1-3		
	Blackout Taillights	Inspect	0.1						
		Test		0.1			1,2		
		Replace		0.5			1-3		
	Rear Floodlights	Inspect	0.1						
		Test		0.1			1,2		
		Replace		0.5			1-3		
0610	Sending Units and Warning Switches								
	Sending Unit Oil Pressure	Inspect	0.1						
		Test		0.1			1,2		
		Replace		0.5			1-3		
	Sending Unit Engine Temperature	Inspect	0.1						
		Test		0.1			1,2		
		Replace		0.5			1-3		
0611	Horn								
	Horn	Test	0.1						
		Replace		0.5			1,2		
	Horn Switch	Test	0.1						
		Replace		0.5			1,2		

Table 1. MAC for the Model MHE 237 Forklift Truck - Continued.

Group Number	Component/ Assembly	Maintenance Function	Maintenance Level					Tools/ Equipment Ref Code	Remarks Code
			Field		Sustainment				
			Unit		DS	GS	Depot		
			C	O	F	H	D		
<b>06</b>	<b>ELECTRICAL SYSTEM - CONTINUED</b>								
0612	Batteries, Storage								
	Batteries	Inspect	0.1						
		Test	0.3						
		Service	0.3						
		Replace		1.0			1,2		
	Battery Cables	Inspect	0.1						
		Replace		0.3			1-3		
		Repair		0.5			1-3		
0613	Hull or Chassis Wiring Harness								
	Wiring Harness	Inspect	0.1						
		Test		0.5			1-3		
		Replace			2.5		3,4,7,8		
		Repair		1.0			2,3,7,8		
<b>07</b>	<b>TRANSMISSION</b>								
0708	Torque Converter or Fluid Coupling								
	Hoses, Lines, and Fittings	Inspect		0.1				1,2	
		Replace		0.5				1-3	
0710	Transmission Assembly								
	Transmission	Test			0.5		3,4		
		Inspect		0.2			1,3		
		Service		0.5			1-3		
		Replace			8.0		3-5		
		Repair				8.0	3-5		
		Overhaul					40.0		

Table 1. MAC for the Model MHE 237 Forklift Truck - Continued.

Group Number	Component/ Assembly	Maintenance Function	Maintenance Level					Tools/ Equipment Ref Code	Remarks Code
			Field		Sustainment				
			Unit		DS	GS	Depot		
			C	O	F	H	D		
<b>07</b>	<b>TRANSMISSION - CONTINUED</b>								
0721	Coolers, Pumps, Motors								
	Transmission Linkage Controls	Inspect		0.1				1,2	
		Adjust		0.5				1-3	
		Replace		1.0				1-3	
		Repair		0.5				1-3	
	Oil Pump	Replace			1.0			3,4,12	
		Repair				1.0		4,5,12	
	Control Valve	Inspect		0.1				1-3	
		Replace			1.0			3,4	
		Repair				2.0		3,4	
	Oil Filter	Service		0.3				1-3	
		Replace		0.5				1-3	
	Oil Cooler (Torque Converter)	Inspect	0.1						
		Replace		2.0				1-3	
		Repair			3.0			3,4	
<b>09</b>	<b>PROPELLER and PROPELLER SHAFTS</b>								
0900	Propeller Shafts								
	Front Drive Shaft	Service		0.1				1,2	
		Replace		1.0				1-3	
		Repair		1.0				1-3	
	Center Drive Shaft	Service		0.1				1,2	
		Replace		1.0				1-3	
		Repair		1.0				1-3	
	Rear Drive Shaft	Service		0.1				1,2	
		Replace		1.0				1-3	
		Repair		1.0				1-3	

Table 1. MAC for the Model MHE 237 Forklift Truck - Continued.

Group Number	Component/ Assembly	Maintenance Function	Maintenance Level					Tools/ Equipment Ref Code	Remarks Code
			Field			Sustainment			
			Unit		DS	GS	Depot		
			C	O	F	H	D		
<b>10</b>	<b>FRONT AXLE</b>								
1000	Front Axle Assembly								
	Front Axle	Inspect		0.1				1,2	
		Service		0.3				1-3	
		Replace			8.0			3,4	
		Repair				4.0		3,4,12,18,19	
		Overhaul					8.0		
1002	Differential Assembly								
	Differential Carrier Assembly	Service		0.5				1-3	
		Replace			4.0			3,4	
		Repair				4.0		3,4,5,12,18,19	
		Overhaul					8.0		
<b>12</b>	<b>BRAKES</b>								
1201	Hand Brake								
	Linkage	Inspect		0.5				1,2	
		Adjust		0.5				1-3	
		Replace		1.0				1-3	
		Repair		1.0				1-3	
	Brake Assembly	Inspect		0.5				1,2	
		Replace		2.0				1-3	
		Repair		2.0				1-3	
1202	Service Brake								
	Service Brake	Inspect		0.5				1,2	
		Replace		0.8				1-3	
1204	Hydraulic Brake System								
	Hydraulic Brake Valve	Inspect		0.1				1,2	
		Replace		1.0				1-3	
		Repair		0.5				1-3	
	Lines, Fittings, and Hoses	Inspect		0.1				1,2	
		Replace		1.0				1-3	

**Table 1. MAC for the Model MHE 237 Forklift Truck - Continued.**

Group Number	Component/ Assembly	Maintenance Function	Maintenance Level					Tools/ Equipment Ref Code	Remarks Code
			Field		Sustainment				
			Unit		DS	GS	Depot		
			C	O	F	H	D		
<b>13</b>	<b>WHEELS</b>								
1311	Wheel Assembly								
	Wheel Assembly	Inspect	0.1						
		Replace		0.8			1-3		
	Tires	Inspect	0.1						
		Service	0.3						
		Replace		1.0			1-3		
		Repair		1.0			1-3		
<b>14</b>	<b>STEERING</b>								
1407	Power Steering Gear Assembly (and Steering Column)								
	Power Steering Gear Assembly (and Steering Column)	Replace			2.0		3,4		
		Repair			3.0		3,4		
1410	Hydraulic Pump or Fluid Motor Assembly	Replace		1.0			1-3		
1411	Hose, Lines and Fittings								
	Hoses, Lines and Fittings	Inspect	0.1						
		Replace		0.5			1-3		
		Repair		0.5			1-3		
1412	Hydraulic Cylinders								
	Steering Cylinder	Inspect	0.1						
		Replace		1.0			1-3		
		Repair			1.0		3,4,10		



Table 1. MAC for the Model MHE 237 Forklift Truck - Continued.

Group Number	Component/ Assembly	Maintenance Function	Maintenance Level					Tools/ Equipment Ref Code	Remarks Code
			Field		Sustainment				
			Unit		DS	GS	Depot		
			C	O	F	H	D		
<b>15</b>	<b>FRAME AND TOWING ATTACHMENTS</b>								
1501	Frame Assembly								
	Rollover Protective Structure	Inspect	0.1						
		Replace		1.0			1-3		
1503	Pintle and Tow Bar								
	Pintle and Tow Bar	Inspect		0.1			1,2		
		Replace		2.0			1-3		
<b>18</b>	<b>BODY, CAB, HOOD, AND HULL</b>								
1801	Body, Cab, and Hood								
	Body	Inspect	0.1						
		Repair			2.0		3,4,13,14		
	Hood	Inspect	0.1						
		Replace		0.7			1-3		
		Repair			2.0		3,4,13,14		
1806	Upholstery Seats and Carpets								
	Seat	Adjust	0.1						
		Inspect	0.2						
		Replace		0.5			1-3		
<b>24</b>	<b>HYDRAULIC LIFT COMPONENTS</b>								
2402	Manifold and/or Control Valves								
	Control Valve	Test		0.2			1-3		
		Replace			1.5		3,4		
		Repair			4.0		3,4		
2403	Hydraulic Controls and/or Manual Controls								
	Controls, Levers, and Linkages	Inspect	0.1						
		Replace		0.5			1-3		
		Repair		0.5			1-3		

Table 1. MAC for the Model MHE 237 Forklift Truck - Continued.

Group Number	Component/ Assembly	Maintenance Function	Maintenance Level					Tools/ Equipment Ref Code	Remarks Code
			Field		Sustainment				
			Unit		DS	GS	Depot		
			C	O	F	H	D		
<b>24</b>	<b>HYDRAULIC LIFT COMPONENTS - CONTINUED</b>								
2404	Tilt Cylinders and Tilt Crank								
	Cylinder Hydraulic Tilt	Inspect	0.1						
		Test		0.2					
		Replace			1.0		3,4		
		Repair			1.5		3,4,10,11,12		
2405	Mast Column								
	Lifting Forks	Inspect	0.1						
		Replace		0.5			1-3		
	Lift Chains	Adjustments		0.5			1-3		
		Removal		0.5			1-3		
		Repair		0.5			1-3		
	Mast Assembly	Replace			2.0		3,4		
		Repair			4.0		3,4,11,12,13		
	Sideshift Cylinder	Test			0.2				
		Inspect		0.1			3,4,10		
		Replace			1.0		3,4		
		Repair			1.5		3,4,10		
	Hydraulic Lift Cylinder	Inspect	0.1						
		Test		0.2			1-3,10		
		Replace			1.5		3,4		
		Repair			2.0		3,4,10		
2406	Strainers, Filters, Lines, and Fittings								
	Hose, Lines, and Fittings	Inspect	0.1						
		Replace		0.5			1-3		
		Repair		0.5			1-3		
2407	Hydraulic Cylinders								
	Rotation Cylinder	Test		0.2			3,4,10		
		Inspect	0.1						
		Replace		1.0			3,4		
		Repair		1.5			3,4,10		

Table 1. MAC for the Model MHE 237 Forklift Truck - Continued.

Group Number	Component/ Assembly	Maintenance Function	Maintenance Level					Tools/ Equipment Ref Code	Remarks Code
			Field			Sustainment			
			Unit		DS	GS	Depot		
			C	O	F	H	D		
24	<b>HYDRAULIC LIFT COMPONENTS - CONTINUED</b>								
2408	Liquid Tanks or Reservoir								
	Hydraulic Reservoir	Inspect	0.1						
		Service		0.1			1-3		
		Replace		0.1			1-3		
		Repair		2.0			1-3		
47	<b>GAGES (ELECTRIC)</b>								
4702	Gages, Fuel Level and Oil Pressure	Inspect	0.1						
		Replace		0.5					

Table 2. Tools and Test Equipment Requirements for the MHE 237 Forklift Truck.

(1) TOOLS OR TEST EQUIPMENT REFERENCE CODE	(2) MAINTENANCE LEVEL	(3) NOMENCLATURE	(4) NATIONAL STOCK NUMBER (NSN)	(5) TOOL NUMBER
1	F,H	Shop equipment, automotive maintenance and repair: field maintenance, basic, less power	4910-00-754-0705	SC 4910-95-CL-A31 (LIN TZ4660)
2	O,F,H	Shop equipment, automotive maintenance and repair: organizational maintenance, common no. 1, less power	4910-00-754-0654	SC4910-95-CL-A74 (LIN W32593)
3	O,F,H	Shop equipment, automotive maintenance and repair: organizational maintenance, common no. 2, less power	4910-00-654-0650	SC4910-95-CL-A72 (LIN W32730)
4	F,H	Shop equipment, automotive maintenance, supplemental tool set no. 2	4910-00-754-0707	SC4910-95-CL-A63 (LIN T25756)
5	F,H	Shop equipment, fuel and electric systems, engine repair	4910-00-654-0714	SC4910-95-CL-A01 (LIN T30414)
6	F,H	Shop equipment, machine shop: field maintenance, basic	3470-00-754-0708	SC3470-95-CL-A02 (LIN T15644)
7	F,H	Shop equipment, welding	3740-00-357-7268	SC3470-95-CL-A08 (LIN T16714)
8	F,H	Sleeve, tool, special	5120-01-220-9439	CAS-1704
9	F,H	Spanner wrench	5120-00-277-9076	5218469
10	F,H	Spanner wrench	5120-00-277-9077	6200463
11	F,H	Test set, diesel injector	4910-00-317-8265	5910359
12	F,H	Test stand, automotive	4910-01-504-2154	6V7830
13	F,H	Tool kit, automotive fuel and electric systems repair	4910-00-754-0655	SC5180-95-CL-B08 (LIN W32456)
14	F,H	Tool kit, body and fender repair	5180-00-754-0643	SC5180-95-CL-N34 (LIN W33680)
15	O,F,M	Tool kit, general mechanic's	5180-01-483-0249	128470000-1

**Table 2. Tools and Test Equipment Requirements for the MHE 237 Forklift Truck - Continued.**

(1) TOOLS OR TEST EQUIPMENT REFERENCE CODE	(2) MAINTENANCE LEVEL	(3) NOMENCLATURE	(4) NATIONAL STOCK NUMBER (NSN)	(5) TOOL NUMBER
16	F,H	Tool kit, machinist's	5280-00-511-1950	SC5280-95-CL- A02 (LIN W44512)
17	F,H	<i>Use: Tool Kit, General Mechanic's</i>	5180-00-699-5273	(LIN W45060)
18	O,F,H	<i>Use: Tool Kit, General Mechanic's</i>	5180-00-177-7033	LIN W33004
19	F,H	Wrench set, socket: 3/4-in. drive, hex type	5130-00-357-5135	GGG-W-660

**Table 3. Remarks for the MHE 237 Forklift Truck.**

REFERENCE CODE	REMARKS
A	Sleeve, Tool, Special, P/N CAS-1704; required to install seal P/N L36272, part of Parts Kit, Linear, P/N G107912.

**END OF WORK PACKAGE**



---

## SUPPORTING INFORMATION

### EXPENDABLE AND DURABLE ITEMS LIST

---

#### SCOPE

Table 1 lists expendable and durable items referenced in this manual. These listings are for informational purposes only and are not authority to requisition the listed items. These items are authorized to you by CTA 50-970, *Expendable/Durable Items (Except Medical, Class V Repair Parts, and Heraldic Items)*, or CTA 8-100, *Army Medical Department Expendable/Durable Items*.

#### EXPLANATION OF COLUMNS

1. **Column (1) - Item Number.** This number is referenced in the appropriate work package Initial Setup list or in the narrative instructions to identify the item; e.g., Use Tape, antiseizing (Item 34, WP 0310).
2. **Column (2) - Level.** This column identifies the lowest level of maintenance that requires the listed item.
  - O - Organizational
  - F - Direct Support
  - H - General Support
3. **Column (3) - National Stock Number.** This is the National Stock Number assigned to the item, which you can use to requisition it.
4. **Column (4) - Description, CAGEC, and Part Number.** This provides the other information you need to identify the item.
5. **Column (5) - Unit of Issue (U/I).** This column shows the physical measurement or count of an item, such as gallon, dozen, gross, etc.

**Table 1. Expendable and Durable Items for the Model MHE 237 Forklift Truck.**

(1) ITEM NUMBER	(2) LEVEL	(3) NATIONAL STOCK NUMBER	(4) DESCRIPTION, CAGEC, AND PART NUMBER	(5) U/I
1	O	8040-00-262-9025 8040-00-262-9028 8040-00-262-9031	Adhesive, rubber (81348) MMM-A-1617 4 Ounce Tube 1 Pint Can 1 Quart Can	TU PT QT
2	F	8040-00-728-3088	Adhesive, silicone (78500) 1199-Q-2981	KT
3	O	8040-01-486-1862 8040-01-126-1422	Adhesive, vinyl (1A9T3) 1099 5 Ounce Tube 1 Quart Can	TU QT
4	O		Antifreeze	
5	H	5210-00-640-6176  5210-00-640-6177  5210-00-640-6178	Bearing clearance gage (Plastigage) (74069) HPB1 0.004 to 0.009 in. Clearance Range Blue, 12 per Box (74069) HPG1 0.001 to 0.003 in. Clearance Range Green, 12 per Box (74069) HPR1 0.002 to 0.006 in. Clearance Range Red, 12 per Box	BX  BX  BX
6	O	9150-01-102-9455	Brake fluid, automotive, silicone (81349) MIL-B-46176 1 Gallon Can	GL
7	O	8020-00-559-0389	Brush, paint (81348) H-B-491	EA
8	O	7920-00-291-5815	Brush, wire (83421) 7920-00-291-5815	EA
9	O	5340-00-450-5718	Cap set, protective Dust and Moisture Seal (19207) 10935405	EA
10	O	6850-01-474-2318 6850-01-474-2320 6850-01-474-2321	Cleaning compound, solvent, Type III (81349) MIL-PRF-680 1 Gallon Can 5 Gallon Can 55 Gallon Drum	GL BX DR



**Table 1. Expendable and Durable Items for the Model MHE 237 Forklift Truck - Continued.**

(1) ITEM NUMBER	(2) LEVEL	(3) NATIONAL STOCK NUMBER	(4) DESCRIPTION, CAGEC, AND PART NUMBER	(5) U/I
11	F	5350-00-192-5047 5350-00-192-5049 5350-00-192-5051	Cloth, abrasive (58536) A-A-1048 80 grit - 50 sheets 120 grit - 50 sheets 180 grit - 50 sheets	PG PG PG
12	O	5350-00-221-0872	Cloth, crocus (81348) P-C-458	PG
13	C		Detergent, general purpose, liquid (83421) 7930-00-282-9699	
14	O	9140-00-286-5286 9140-00-286-5287 9140-00-286-5288	Diesel fuel, DF-1 grade, arctic (81346) ASTM D 975 Bulk 5 Gallon Can 55 Gallon Drum	GL CN DR
15	O	9140-00-286-5294 9140-00-286-5295 9140-00-286-5296	Diesel fuel, DF-2 grade (81346) ASTM D 975 Bulk 5 Gallon Can 55 Gallon Drum	GL CN DR
16	O	9130-01-031-5816	Fuel, turbine, aviation (81349) MIL-T-83133 GR JP-8	GL
17	O	9150-01-197-7688 9150-01-197-7693 9150-01-197-7690 9150-01-197-7692	Grease, automotive and artillery (GAA) (81349) M-10924-A 2-1/4 Ounce Tube (81349) M-10924-B 14 Ounce Cartridge (81349) M-10924-C 1-3/4 Pound Can (81349) M-10924-E 35 Pound Can	TU CA CN CN
18	H	8010-00-152-3245 8010-00-684-8789	Linseed oil (96162) Boiled Linseed Oil 1 Gallon Can 5 Gallon Can	GL CN

**Table 1. Expendable and Durable Items for the Model MHE 237 Forklift Truck - Continued.**

(1) ITEM NUMBER	(2) LEVEL	(3) NATIONAL STOCK NUMBER	(4) DESCRIPTION, CAGEC, AND PART NUMBER	(5) U/I
19	O	9150-00-402-4478 9150-00-402-2372 9150-00-491-7197	Lubricating oil, engine OEA, Arctic (81349) MIL-L-46167 1 Quart Can 5 Gallon Can 55 Gallon Drum	QT CN DR
20	O	9150-00-189-6727 9150-00-186-6668 9150-00-191-2772	Lubricating oil, engine OE/HDO-10 (81349) MIL-PRF-2104 1 Quart Can 5 Gallon Can 55 Gallon Drum	QT CN DR
21	O	9150-01-152-4117 9150-01-152-4118 9150-01-152-4119	Lubricating oil, engine OE/HDO-15/40 (81349) MIL-PRF-2104 1 Quart Can 5 Gallon Can 55 Gallon Drum	QT CN DR
22	O	9150-01-035-5393	Lubricating oil, gear (81349) MIL-L-2105 5 Gallon Can	CN
23	O	7050-00-961-7663	Lubriplate lubricant (90536) ST40334	OZ
24	F	8010-01-492-6650	Paint, black (81349) MIL-DTL-64159	KT
25	H	8010-00-664-1414	Pigment, paint products (Prussian Blue) (58536) AA3108-2A-001Q 1 Quart Can	CN
26	O	7290-00-205-1711	Rag, wiping (80244) 7920-00-205-1711 50 Pound Bale	BE
27	H	8010-00-243-9265	Red lead (81346) ASTM D83	GL
28	H	8030-01-014-5869	Sealing compound, blue (81349) MIL-S-46163 50 cc Plastic Squeeze Bottle	BT

**Table 1. Expendable and Durable Items for the Model MHE 237 Forklift Truck - Continued.**

(1) ITEM NUMBER	(2) LEVEL	(3) NATIONAL STOCK NUMBER	(4) DESCRIPTION, CAGEC, AND PART NUMBER	(5) U/I
29	H	8030-00-833-9116	Sealing compound, brown (81349) MIL-S-22473 50 cc Bottle	BT
30	F	8030-00-025-3391	Sealing compound, Permatex 2 (81349) MIL-S-45180 11 Ounce Tube	TU
31	O	6850-01-159-4844	Silicone compound, RTV rubber sealant (7X677) 12346141 10.14 Ounce Tube	BX
32	O	5975-00-903-2284	Strap, tiedown, electrical components 4 in. Length, Black, Package of 100 (96906) MS3367-4-0	HD
		5975-00-984-6582	6 in. Length, Black, Package of 100 (96906) MS3367-1-0	HD
		5975-00-935-5946	13.35 in. Minimum Length, Brown (96906) MS3367-2-1	EA
33	O	9905-00-537-8954	Tag, marker (64067) 9905-00-537-8954 Bundle of 50	BD
34	O	8030-00-889-3535	Tape, antiseizing, teflon (81349) MIL-T-27730 1/2 in. W x 260 in. L x 0.0035 in. Thick	EA
35	O	5970-00-644-3167	Tape, insulation, electrical (80063) TL83 3/4 in. W x 85 ft L x 0.0180 in. Thick	RO

**END OF WORK PACKAGE**



**INDEX**

**Subject**

**WP Sequence No.-Page No.**

**Numerics**

25 Amp Breaker Replacement (Model 4-390) . . . . . WP 0100-1

**A**

Accelerator and Throttle Control Maintenance

    Model 207 . . . . . WP 0074-1

    Model 4-390 . . . . . WP 0075-1

Adapter

    Wiring Harness Maintenance (Model 4-390) . . . . . WP 0139-1

    Wiring Harness Replacement (Model 4-390) . . . . . WP 0244-1

Administrative Storage . . . . . WP 0001-1

Air Cleaner Maintenance

    Model 207 . . . . . WP 0061-1

    Model 4-390 . . . . . WP 0062-1

Alternator

    Direct Support Troubleshooting (Model 207) . . . . . WP 0034-1

    Maintenance

        Model 207 . . . . . WP 0093-1

        Model 4-390 . . . . . WP 0094-1

    Repair (Model 207) . . . . . WP 0237-1

Axle

    and Wheels Theory of Operation . . . . . WP 0002-7

    Direct Support Troubleshooting . . . . . WP 0039-1

    Disconnect Lever Replacement . . . . . WP 0149-1

    Front

        Air Breather Replacement . . . . . WP 0158-1

        Differential Carrier Replacement . . . . . WP 0255-1

        Maintenance . . . . . WP 0157-1

        Replacement . . . . . WP 0253-1

        Shaft and Bearings Maintenance . . . . . WP 0160-1

    Organizational Troubleshooting . . . . . WP 0020-1

    Rear

        Air Breather Replacement . . . . . WP 0159-1

        Differential Carrier Replacement . . . . . WP 0256-1

        Maintenance . . . . . WP 0157-1

        Replacement . . . . . WP 0254-1

        Shaft and Bearings Maintenance . . . . . WP 0160-1

        Trunnion Replacement . . . . . WP 0303-1

**B**

Back-up Alarm

    Organizational Troubleshooting . . . . . WP 0016-1

    Replacement

        Model 207 . . . . . WP 0130-1

        Model 4-390 . . . . . WP 0131-1

    Switch Replacement

        Model 207 . . . . . WP 0118-1

        Model 4-390 . . . . . WP 0119-1

**INDEX - CONTINUED**

**Subject** **WP Sequence No.-Page No.**

**B - Continued**

Battery	
Cables Replacement	
Model 207 .....	WP 0133-1
Model 4-390 .....	WP 0134-1
Cover Maintenance .....	WP 0132-1
Organizational Troubleshooting	
Model 207 .....	WP 0010-1
Model 4-390 .....	WP 0011-1
Replacement	
Model 207 .....	WP 0133-1
Model 4-390 .....	WP 0134-1
Blackout Lights Maintenance	
Front .....	WP 0113-1
Rear .....	WP 0114-1
Body and Towing Attachments Theory of Operation .....	WP 0002-8
Brake	
Hoses, Lines, and Fittings Replacement .....	WP 0164-1
Master Cylinder Replacement .....	WP 0165-1
Organizational Troubleshooting .....	WP 0021-1
Parking	
Linkage Maintenance .....	WP 0161-1
Maintenance .....	WP 0162-1
Pedal Maintenance .....	WP 0168-1
Power Assist Unit Maintenance .....	WP 0166-1
Service Maintenance .....	WP 0163-1
Theory of Operation .....	WP 0002-7

**C**

Camshaft and Bearings Maintenance	
Model 207 .....	WP 0282-1
Model 4-390 .....	WP 0283-1
Carriage Maintenance .....	WP 0267-1
Charging System	
Organizational Troubleshooting	
Model 207 .....	WP 0014-1
Model 4-390 .....	WP 0015-1
Chassis	
Direct Support Troubleshooting .....	WP 0042-1
Floor Plate and Guard Replacement .....	WP 0188-1
Separation of Front and Rear .....	WP 0261-1
Stop Bumper Replacement .....	WP 0175-1
Clutch	
Forward Repair .....	WP 0298-1
Low Repair .....	WP 0296-1
Reverse and Second Repair .....	WP 0295-1
Third Repair .....	WP 0297-1
Transmission Repair .....	WP 0293-1
Common Tools and Equipment .....	WP 0001-1

**INDEX - CONTINUED**

**Subject** **WP Sequence No.-Page No.**

**C - Continued**

Control Valve	
Repair	WP 0299-1
Transmission, Inspection	WP 0151-1
Coolant Inlet Manifold Replacement (Model 4-390)	WP 0092-1
Cooling System	
Organizational Troubleshooting	WP 0009-1
Theory of Operation	WP 0002-3
Crankshaft	
and Main Bearings Replacement	
Model 207	WP 0276-1
Model 4-390	WP 0277-1
Oil Seal Retainer Replacement (Model 207)	WP 0274-1
Cylinder	
Block Inspection	
Model 207	WP 0215-1
Model 4-390	WP 0216-1
Block Repair	
Model 207	WP 0270-1
Model 4-390	WP 0271-1
Head and Valves Repair	
Model 207	WP 0272-1
Model 4-390	WP 0273-1
Head Replacement	
Model 207	WP 0218-1
Model 4-390	WP 0219-1

**D**

Data, Instructions, and Warranty Plates	WP 0003-2
Declutch	
Pedal Maintenance	WP 0168-1
Valve Maintenance	WP 0167-1
Destruction of Army Materiel to Prevent Enemy Use	WP 0001-1
Diagrams, Electrical and Hydraulic	WP 0306-1
Differential	
Carrier Repair	WP 0300-1
Case and Gears Repair	WP 0302-1
Direct Support Troubleshooting	
Alternator (Model 207)	WP 0034-1
Axles and Differential Carrier Assemblies	WP 0039-1
Chassis	WP 0042-1
Engine	
Model 207	WP 0030-1
Model 4-390	WP 0031-1
Fuel System	
Model 207	WP 0032-1
Model 4-390	WP 0033-1
Hydraulic Lift System	WP 0043-1

**INDEX - CONTINUED**

**Subject** **WP Sequence No.-Page No.**

**D - Continued**

Direct Support Troubleshooting - Continued	
Hydraulic Pump	WP 0040-1
Introduction	WP 0028-1
Starter and Solenoid (Model 207)	WP 0035-1
Steering	
Column	WP 0041-1
Cylinder	WP 0041-1
Symptom Index	WP 0029-1
Transmission	WP 0038-1
Wiring Harness	
Model 207	WP 0036-1
Model 4-390	WP 0037-1
Draining and Filling	
Engine Crankcase	
Model 207	WP 0049-1
Model 4-390	WP 0050-1
Hydraulic Reservoir	WP 0198-1
Transmission	WP 0143-1
Drive Shaft	
Center Maintenance	WP 0155-1
Front Maintenance	WP 0154-1
Rear Maintenance	WP 0156-1
Theory of Operation	WP 0002-6

**E**

Electrical System	
Instrument Panel	
Gages and Indicators	WP 0002-4
Switches and Gage Lights	WP 0002-5
Theory of Operation	WP 0002-4
Engine	
Direct Support Troubleshooting	
Model 207	WP 0030-1
Model 4-390	WP 0031-1
Mount Replacement	
Model 207	WP 0209-1
Model 4-390	WP 0210-1
Oil Cooler Maintenance (Model 4-390)	WP 0228-1
Oil Pan Maintenance	
Model 207	WP 0226-1
Model 4-390	WP 0227-1
Oil Pressure Switch Maintenance	
Model 207	WP 0123-1
Model 4-390	WP 0124-1
Organizational Troubleshooting	WP 0006-1
Temperature Switch Maintenance	
Model 207	WP 0120-1
Model 4-390	WP 0122-1
Theory of Operation	WP 0002-1



**INDEX - CONTINUED**

**Subject**

**WP Sequence No.-Page No.**

**E - Continued**

Equipment Data .....	WP 0003-5
Exhaust	
Manifold Replacement	
Model 207 .....	WP 0055-1
Model 4-390 .....	WP 0056-1
Organizational Troubleshooting .....	WP 0008-1
Pipe and Spark Arresting Muffler Maintenance	
Model 207 .....	WP 0076-1
Model 4-390 .....	WP 0077-1
Theory of Operation .....	WP 0002-3
Expendable and Durable Items List .....	WP 0310-1

**F**

Fan	
and Fan Belt Maintenance (Model 207) .....	WP 0088-1
and Fan Belt Replacement (Model 4-390) .....	WP 0089-1
Belt Tensioner Replacement (Model 4-390) .....	WP 0090-1
Pulley Bracket Maintenance (Model 4-390) .....	WP 0091-1
Fenders Replacement .....	WP 0178-1
Floodlights	
Maintenance	
Model 207 .....	WP 0111-1
Model 4-390 .....	WP 0112-1
Switches and Circuit Breakers Replacement .....	WP 0104-1
Flywheel	
and Flywheel Housing Replacement	
Model 207 .....	WP 0278-1
Model 4-390 .....	WP 0279-1
Housing Inspection	
Model 207 .....	WP 0220-1
Model 4-390 .....	WP 0221-1
Inspection	
Model 207 .....	WP 0047-1
Model 4-390 .....	WP 0048-1
Forklift Truck Theory of Operation .....	WP 0002-1
Forward Clutch Repair .....	WP 0298-1
Front Cover Panel Replacement .....	WP 0184-1
Front Wiring Harness Maintenance	
Model 207 .....	WP 0135-1
Model 4-390 .....	WP 0136-1
Fuel	
Filter	
Maintenance (Model 207) .....	WP 0069-1
Servicing and Replacement (Model 4-390) .....	WP 0072-1
Gage Sending Unit Replacement .....	WP 0117-1

**INDEX - CONTINUED**

**Subject** **WP Sequence No.-Page No.**

**F - Continued**

Fuel - Continued

Injection

Lines and Fittings Maintenance

Model 207 ..... WP 0229-1

Model 4-390 ..... WP 0230-1

Pump Adjustments

Model 207 ..... WP 0208-1

Pump Repair (Model 207) ..... WP 0289-1

Injection Pump Replacement

Model 207 ..... WP 0233-1

Model 4-390 ..... WP 0234-1

Injection Pump Testing

Model 207 ..... WP 0057-1

Model 4-390 ..... WP 0058-1

Injection Wiring Harness

Maintenance (Model 4-390) ..... WP 0141-1

Replacement (Model 4-390) ..... WP 0246-1

Injector

Maintenance (Model 4-390) ..... WP 0232-1

Repair (Model 207) ..... WP 0288-1

Replacement (Model 207) ..... WP 0231-1

Pump and Lines Maintenance

Model 207 (Electric) ..... WP 0059-1

Model 4-390 ..... WP 0060-1

Tank Lines and Fittings Replacement

Model 207 ..... WP 0065-1

Model 4-390 ..... WP 0066-1

Tank Servicing

Model 207 ..... WP 0063-1

Model 4-390 ..... WP 0064-1

Tank Strainer Replacement

Model 207 ..... WP 0070-1

Model 4-390 ..... WP 0071-1

Fuel System

Direct Support Troubleshooting

Model 207 ..... WP 0032-1

Model 4-390 ..... WP 0033-1

Organizational Troubleshooting ..... WP 0007-1

Theory of Operation ..... WP 0002-2

**G**

Gage

Bulb Replacement ..... WP 0202-1

Organizational Troubleshooting ..... WP 0027-1

Replacement ..... WP 0203-1

Grille Maintenance ..... WP 0177-1

INDEX - CONTINUED

<u>Subject</u>	<u>WP Sequence No.-Page No.</u>
<b>H</b>	
Hood	
Panel Replacement	
Model 207 . . . . .	WP 0182-1
Panels Replacement	
Model 4-390 . . . . .	WP 0183-1
Support Plates Replacement	
Model 207 . . . . .	WP 0182-1
Model 4-390 . . . . .	WP 0183-1
Top Replacement	
Model 207 . . . . .	WP 0180-1
Model 4-390 . . . . .	WP 0181-1
Horn	
Organizational Troubleshooting . . . . .	WP 0016-1
Replacement	
Model 207 . . . . .	WP 0127-1
Model 4-390 . . . . .	WP 0128-1
Hourmeter Replacement . . . . .	WP 0110-1
Hydraulic	
Control Levers and Linkages Maintenance . . . . .	WP 0191-1
Control Valve Maintenance . . . . .	WP 0262-1
Draining and Filling Reservoir . . . . .	WP 0198-1
Filter Restriction Switch Replacement . . . . .	WP 0125-1
Hoses, Lines, and Fittings	
Hydraulic Oil Filter to Control Valve to Mast Replacement . . . . .	WP 0195-1
Serial No. 9150572 and Below, Replacement (Mast) . . . . .	WP 0196-1
Serial No. 9150573 and Above Replacement (Mast) . . . . .	WP 0197-1
Lift System	
Direct Support Troubleshooting . . . . .	WP 0043-1
Operational Test . . . . .	WP 0190-1
Organizational Troubleshooting . . . . .	WP 0026-1
Oil Filter and Filter Head Replacement . . . . .	WP 0199-1
Oil Reservoir	
and Air Breather Replacement . . . . .	WP 0201-1
Strainer Replacement . . . . .	WP 0200-1
Pump	
Direct Support Troubleshooting . . . . .	WP 0040-1
Repair . . . . .	WP 0259-1
Replacement . . . . .	WP 0170-1
System	
Theory of Operation . . . . .	WP 0002-9
<b>I</b>	
Ignition Switch and Circuit Breaker Replacement . . . . .	WP 0106-1
Illustrated List of Manufactured Items . . . . .	WP 0305-1
In-Line Fuel Filter Replacement	
Model 207 . . . . .	WP 0067-1
Model 4-390 . . . . .	WP 0068-1

**INDEX - CONTINUED**

<u>Subject</u>	<u>WP Sequence No.-Page No.</u>
<b>I - Continued</b>	
Inner and Outer Mast Maintenance .....	WP 0269-1
Instrument Panel	
Organizational Troubleshooting .....	WP 0018-1
Replacement .....	WP 0239-1
Intake Manifold Replacement	
Model 207 .....	WP 0053-1
Model 4-390 .....	WP 0054-1
Introductory Information .....	WP 0001-1
<b>L</b>	
Lift Chains and Pulleys Maintenance .....	WP 0193-1
Lift Cylinder Maintenance .....	WP 0266-1
Lifting Forks Replacement .....	WP 0192-1
Light System Organizational Troubleshooting .....	WP 0017-1
Locating Top Dead Center	
Model 207 .....	WP 0204-1
Model 4-390 .....	WP 0205-1
Lock-out Relay Replacement .....	WP 0107-1
Low Clutch Repair .....	WP 0296-1
<b>M</b>	
Maintenance Allocation Chart (MAC)	
Introduction .....	WP 0308-1
Table .....	WP 0309-1
Maintenance Forms, Records, and Reports .....	WP 0001-1
Modulation Valve Repair .....	WP 0301-1
<b>N</b>	
Neutral Start Switch Replacement	
Model 207 .....	WP 0118-1
Model 4-390 .....	WP 0119-1
Noise Baffle Mat Replacement .....	WP 0187-1
<b>O</b>	
Oil	
Cooler Replacement	
Transmission .....	WP 0153-1
Filter Replacement	
Model 207 .....	WP 0051-1
Model 4-390 .....	WP 0052-1
Transmission .....	WP 0146-1
Pump	
Maintenance (Model 207) .....	WP 0286-1
Replacement (Model 4-390) .....	WP 0287-1
Operator's Seat Maintenance	
Model 207 .....	WP 0185-1
Model 4-390 .....	WP 0186-1

**INDEX - CONTINUED**

**Subject**

**WP Sequence No.-Page No.**

**O - Continued**

Organizational Troubleshooting	
Axles and Drive Shaft Assemblies	WP 0020-1
Back-up Alarms System	WP 0016-1
Battery	
Model 207	WP 0010-1
Model 4-390	WP 0011-1
Body, Cab, and Hood	WP 0025-1
Brake System	WP 0021-1
Charging System	
Model 207	WP 0014-1
Model 4-390	WP 0015-1
Cooling System	WP 0009-1
Engine	WP 0006-1
Exhaust System	WP 0008-1
Frame and Towing Attachments	WP 0024-1
Fuel System	WP 0007-1
Gages	WP 0027-1
Horn	WP 0016-1
Hydraulic Lift System	WP 0026-1
Instrument Panel	WP 0018-1
Introduction	WP 0004-1
Light System	WP 0017-1
Starting System	
Model 207	WP 0012-1
Model 4-390	WP 0013-1
Steering System	WP 0023-1
Symptom Index	WP 0005-1
Transmission	WP 0019-1
Wheels and Tires	WP 0022-1

**P**

Panel Replacement	
Front Cover	WP 0184-1
Hood	
Model 207	WP 0182-1
Model 4-390	WP 0183-1
Parking Brake	
Linkage Maintenance	WP 0161-1
Maintenance	WP 0162-1
Pistons and Connecting Rods Maintenance	
Model 207	WP 0280-1
Model 4-390	WP 0281-1
Power Pack Replacement	
Model 207	WP 0211-1
Model 4-390	WP 0212-1

**INDEX - CONTINUED**

<u>Subject</u>	<u>WP Sequence No.-Page No.</u>
<b>P - Continued</b>	
Preventive Maintenance Checks and Services (PMCS)	
Introduction .....	WP 0045-1
Procedures .....	WP 0046-1
<b>Q</b>	
Quick Start Kit Replacement .....	WP 0073-1
<b>R</b>	
Radiator	
and Shroud Maintenance	
Model 207 .....	WP 0082-1
Model 4-390 .....	WP 0083-1
Hoses Replacement	
Model 207 .....	WP 0080-1
Model 4-390 .....	WP 0081-1
Repair	
Model 207 .....	WP 0235-1
Model 4-390 .....	WP 0236-1
Servicing	
Model 207 .....	WP 0078-1
Model 4-390 .....	WP 0079-1
Shroud Repair	
Model 207 .....	WP 0235-1
Model 4-390 .....	WP 0236-1
Rear Blackout Lights Maintenance .....	WP 0114-1
Rear Drive Shaft Maintenance .....	WP 0156-1
Rear Wiring Harness Maintenance	
Model 207 .....	WP 0137-1
Model 4-390 .....	WP 0138-1
References .....	WP 0307-1
Relay Panel	
Cover and Capacitor Replacement (Model 4-390) .....	WP 0098-1
Wiring Harness	
Maintenance (Model 4-390) .....	WP 0140-1
Relay Panel Wiring Harness	
Replacement (Model 4-390) .....	WP 0245-1
Repair Parts .....	WP 0001-1
Reporting Errors .....	WP 0001-1
Resistor Replacement (Model 4-390) .....	WP 0103-1
Reverse and Second Clutch Repair .....	WP 0295-1
Rocker Arm	
Assembly Maintenance	
Model 207 .....	WP 0224-1
Model 4-390 .....	WP 0225-1
Cover Maintenance	
Model 207 .....	WP 0222-1
Cover Replacement	
Model 4-390 .....	WP 0223-1
Rollover Protective Structure Replacement .....	WP 0174-1

INDEX - CONTINUED

Subject

WP Sequence No.-Page No.

R - Continued

Rotation Cylinder Maintenance . . . . . WP 0265-1

S

Sending Unit Maintenance

Model 207 . . . . . WP 0123-1

Model 4-390 . . . . . WP 0124-1

Separation of

Engine and Transmission

Model 207 . . . . . WP 0213-1

Model 4-390 . . . . . WP 0214-1

Front and Rear Chassis . . . . . WP 0261-1

Service Brake Maintenance . . . . . WP 0163-1

Service Upon Receipt . . . . . WP 0044-1

Side Panels Maintenance . . . . . WP 0179-1

Sideshift

Chains and Pulleys Maintenance . . . . . WP 0194-1

Cylinder Maintenance . . . . . WP 0264-1

Frame Maintenance . . . . . WP 0268-1

Rotation Bearing Maintenance . . . . . WP 0268-1

Slave Receptacle Replacement . . . . . WP 0109-1

Spark Arresting Muffler and Exhaust Pipe Maintenance

Model 207 . . . . . WP 0076-1

Model 4-390 . . . . . WP 0077-1

Start Switch Replacement . . . . . WP 0105-1

Starter

and Solenoid

Direct Support Troubleshooting (Model 207) . . . . . WP 0035-1

Repair (Model 207) . . . . . WP 0238-1

Lock-out Relay Replacement (Model 4-390) . . . . . WP 0099-1

Maintenance (Model 207) . . . . . WP 0095-1

Relay and 25 Amp Circuit Breaker Replacement (Model 207) . . . . . WP 0097-1

Relay Replacement (Model 4-390) . . . . . WP 0102-1

Replacement (Model 4-390) . . . . . WP 0096-1

Starting System

Organizational Troubleshooting

Model 207 . . . . . WP 0012-1

Model 4-390 . . . . . WP 0013-1

Steering

Column Direct Support Troubleshooting . . . . . WP 0041-1

Column Maintenance . . . . . WP 0257-1

Cylinder Direct Support Troubleshooting . . . . . WP 0041-1

Cylinder Repair . . . . . WP 0260-1

Cylinder Replacement . . . . . WP 0173-1

Gear Maintenance . . . . . WP 0258-1

**INDEX - CONTINUED**

**Subject**

**WP Sequence No.-Page No.**

**S - Continued**

Steering - Continued	
Hoses, Lines, and Fittings Maintenance	
Hydraulic Pump To Steering Gear .....	WP 0172-1
Steering Gear to Steering Cylinder .....	WP 0171-1
Wheel Maintenance .....	WP 0257-1
Steering System	
Organizational Troubleshooting .....	WP 0023-1
Theory of Operation .....	WP 0002-8
Stop and Taillights Maintenance	
Model 207 .....	WP 0115-1
Model 4-390 .....	WP 0116-1
Stop Light Switch Replacement .....	WP 0126-1
Stowage Box Replacement (Model 4-390) .....	WP 0189-1
Support Bearing Maintenance .....	WP 0154-1
Switch Replacement	
Back-up Alarm	
Model 207 .....	WP 0118-1
Model 4-390 .....	WP 0119-1
Engine Oil Pressure	
Model 207 .....	WP 0123-1
Model 4-390 .....	WP 0124-1
Engine Temperature	
Model 207 .....	WP 0120-1
Model 4-390 .....	WP 0122-1
Floodlight .....	WP 0104-1
Hydraulic Filter Restriction .....	WP 0125-1
Ignition .....	WP 0106-1
Neutral Start	
Model 207 .....	WP 0118-1
Model 4-390 .....	WP 0119-1
Start .....	WP 0105-1
Stop Light .....	WP 0126-1
Transmission Temperature	
Model 207 .....	WP 0121-1
Model 4-390 .....	WP 0122-1
Vehicle Lights .....	WP 0105-1

**T**

Tabulated Data .....	WP 0003-1
Tachometer Drive Replacement (Model 207) .....	WP 0217-1
Terminal Block Replacement (Model 4-390) .....	WP 0101-1
Thermostat and Housing Maintenance	
Model 207 .....	WP 0084-1
Model 4-390 .....	WP 0085-1
Third Clutch Repair .....	WP 0297-1
Tilt Cylinders Maintenance .....	WP 0263-1
Timing Gear Cover Replacement	
Model 207 .....	WP 0284-1
Model 4-390 .....	WP 0285-1



**INDEX - CONTINUED**

**Subject**

**WP Sequence No.-Page No.**

**T - Continued**

Tire Maintenance .....	WP 0169-1
Torque	
Converter	
Housing Repair .....	WP 0291-1
Repair .....	WP 0290-1
Limits .....	WP 0304-1
Tow Bar, Tow Chains, and Pintle Hook Replacement .....	WP 0176-1
Transmission	
Air Breather Replacement .....	WP 0145-1
Charging Pump Replacement .....	WP 0251-1
Control Valve Inspection .....	WP 0151-1
Control Valve Replacement .....	WP 0250-1
Dipstick Tube Replacement .....	WP 0150-1
Direct Support Troubleshooting .....	WP 0038-1
Draining and Filling .....	WP 0143-1
Gears and Clutches Repair .....	WP 0293-1
Hoses, Lines, and Fittings Replacement .....	WP 0152-1
Housing Repair .....	WP 0294-1
Inspection .....	WP 0147-1
Linkage Controls Maintenance .....	WP 0148-1
Modulation Valve Replacement .....	WP 0250-1
Mounts Replacement .....	WP 0249-1
Oil Cooler	
Repair .....	WP 0252-1
Replacement .....	WP 0153-1
Oil Filter Replacement .....	WP 0146-1
Organizational Troubleshooting .....	WP 0019-1
Pressure Checks .....	WP 0248-1
Rear Cover Replacement .....	WP 0292-1
Screen Replacement .....	WP 0144-1
Temperature Switch	
Maintenance (Model 4-390) .....	WP 0122-1
Replacement (Model 207) .....	WP 0121-1
Theory of Operation .....	WP 0002-6

**V**

Valve Tappet Clearance Adjustment	
Model 207 .....	WP 0206-1
Model 4-390 .....	WP 0207-1
Vehicle	
Configurations, Different .....	WP 0001-2
Lights Switch Replacement .....	WP 0105-1

**W**

Warning Lights and Diodes Maintenance .....	WP 0108-1
Warranty Information .....	WP 0001-1

**INDEX - CONTINUED**

<u>Subject</u>	<u>WP Sequence No.-Page No.</u>
<b>W - Continued</b>	
Water Pump Replacement	
Model 207 .....	WP 0086-1
Model 4-390 .....	WP 0087-1
Wheels	
Maintenance .....	WP 0169-1
Organizational Troubleshooting .....	WP 0022-1
Wiring Harness	
Adapter	
Maintenance (Model 4-390) .....	WP 0139-1
Replacement (Model 4-390) .....	WP 0244-1
Cable	
Maintenance (Model 4-390) .....	WP 0142-1
Replacement (Model 4-390) .....	WP 0247-1
Direct Support Troubleshooting	
Model 207 .....	WP 0036-1
Model 4-390 .....	WP 0037-1
Front Maintenance	
Model 207 .....	WP 0135-1
Model 4-390 .....	WP 0136-1
Front Replacement	
Model 207 .....	WP 0240-1
Model 4-390 .....	WP 0241-1
Fuel Injection	
Maintenance (Model 4-390) .....	WP 0141-1
Replacement (Model 4-390) .....	WP 0246-1
Rear Maintenance	
Model 207 .....	WP 0137-1
Model 4-390 .....	WP 0138-1
Rear Replacement	
Model 207 .....	WP 0242-1
Model 4-390 .....	WP 0243-1
Relay Panel	
Maintenance (Model 4-390) .....	WP 0140-1
Replacement (Model 4-390) .....	WP 0245-1

<b>RECOMMENDED CHANGES TO PUBLICATIONS AND BLANK FORMS</b> For use of this form, see AR 25-30; the proponent agency is OAASA						Use Part II ( <i>reverse</i> ) for Repair Parts and Special Tool Lists (RPSTL) and Supply Catalogs/Supply Manuals (SC/SM).	DATE <b>1 July 2009</b>
<b>TO:</b> ( <i>Forward to proponent of publication or form</i> ) ( <i>Include ZIP Code</i> ) AMSTA-LC-LMPP/TECH PUBS, TACOM-RI 1 Rock Island Arsenal Rock Island, IL 61299-7630						<b>FROM:</b> ( <i>Activity and location</i> ) ( <i>Include ZIP Code</i> )	
<b>PART I - ALL PUBLICATIONS (EXCEPT RPSTL AND SC/SM) AND BLANK FORMS</b>							
PUBLICATION/FORM NUMBER TM 10-3930-638-24						DATE 15 July 2008	TITLE Field Maintenance (Including Unit, DS, and GS) for Truck, Forklift, DED, Pneumatic Tire, Articulated Frame Steer, 4000 lb Capacity Rough Terrain, Army Model MHE 237
ITEM	PAGE	PARA-	LINE	FIGURE NO.	TABLE	RECOMMENDED CHANGES AND REASON	
<h1>SAMPLE</h1>							
TYPED NAME, GRADE OR TITLE					TELEPHONE EXCHANGE/AUTOVON, PLUS EXTENSION		SIGNATURE

<b>TO:</b> <i>(Forward direct to addressee listed in publication)</i> AMSTA-LC-LMPP/TECH PUBS, TACOM-RI 1 Rock Island Arsenal Rock Island, IL 61299-7630	<b>FROM:</b> <i>(Activity and location) (Include ZIP Code)</i>	<b>DATE</b>
---	--	-------------

**PART II - REPAIR PARTS AND SPECIAL TOOL LISTS AND SUPPLY CATALOGS/SUPPLY MANUALS**

<b>PUBLICATION NUMBER</b> TM 10-3930-638-24	<b>DATE</b> 15 July 2008	<b>TITLE</b> Field Maintenance (Including Unit, DS, and GS) for Truck, Forklift, DED, Pneumatic Tire, Articulated Frame Steer, 4000 lb Capacity Rough Terrain, Army Model MHE 237
--	-----------------------------	--

PAGE NO.	COLM NO.	LINE NO.	NATIONAL STOCK NUMBER	REFERENCE NO.	FIGURE NO.	ITEM NO.	TOTAL NO. OF MAJOR ITEMS SUPPORTED	RECOMMENDED ACTION
					34			Part number supplied for item 2 is incorrect.

**SAMPLE**

**PART III - REMARKS** *(For use in recording changes, corrections, or supplements to the information contained in the publications and drawings. Additional sheets may be used if space is needed.)*

TYPED NAME, GRADE OR TITLE	TELEPHONE EXCHANGE/AUTOVON, PLUS EXTENSION	SIGNATURE
----------------------------	--	-----------

<b>RECOMMENDED CHANGES TO PUBLICATIONS AND BLANK FORMS</b> For use of this form, see AR 25-30; the proponent agency is OAASA						Use Part II (reverse) for Repair Parts and Special Tool Lists (RPSTL) and Supply Catalogs/Supply Manuals (SC/SM).	DATE	
<b>TO:</b> (Forward to proponent of publication or form) (Include ZIP Code) AMSTA-LC-LMPP/TECH PUBS, TACOM-RI 1 Rock Island Arsenal Rock Island, IL 61299-7630						<b>FROM:</b> (Activity and location) (Include ZIP Code)		
<b>PART I - ALL PUBLICATIONS (EXCEPT RPSTL AND SC/SM) AND BLANK FORMS</b>								
PUBLICATION/FORM NUMBER TM 10-3930-638-24						DATE 15 July 2008	TITLE Field Maintenance (Including Unit, DS, and GS) for Truck, Forklift, DED, Pneumatic Tire, Articulated Frame Steer, 4000 lb Capacity Rough Terrain, Army Model MHE 237	
ITEM	PAGE	PARA-	LINE	FIGURE NO.	TABLE	RECOMMENDED CHANGES AND REASON		
TYPED NAME, GRADE OR TITLE						TELEPHONE EXCHANGE/AUTOVON, PLUS EXTENSION		SIGNATURE

<b>TO:</b> <i>(Forward direct to addressee listed in publication)</i> AMSTA-LC-LMPP/TECH PUBS, TACOM-RI 1 Rock Island Arsenal Rock Island, IL 61299-7630	<b>FROM:</b> <i>(Activity and location) (Include ZIP Code)</i>	<b>DATE</b>
---	--	-------------

**PART II - REPAIR PARTS AND SPECIAL TOOL LISTS AND SUPPLY CATALOGS/SUPPLY MANUALS**

<b>PUBLICATION NUMBER</b> TM 10-3930-638-24	<b>DATE</b> 15 July 2008	<b>TITLE</b> Field Maintenance (Including Unit, DS, and GS) for Truck, Forklift, DED, Pneumatic Tire, Articulated Frame Steer, 4000 lb Capacity Rough Terrain, Army Model MHE 237
--	-----------------------------	--

PAGE NO.	COLM NO.	LINE NO.	NATIONAL STOCK NUMBER	REFERENCE NO.	FIGURE NO.	ITEM NO.	TOTAL NO. OF MAJOR ITEMS SUPPORTED	RECOMMENDED ACTION

**PART III - REMARKS** *(Any general remarks or recommendations, or suggestions for improvement of publications and blank forms. Additional blank sheets may be used if more space is needed.)*

TYPED NAME, GRADE OR TITLE	TELEPHONE EXCHANGE/AUTOVON, PLUS EXTENSION	SIGNATURE
----------------------------	--	-----------

<b>RECOMMENDED CHANGES TO PUBLICATIONS AND BLANK FORMS</b> For use of this form, see AR 25-30; the proponent agency is OAASA						Use Part II ( <i>reverse</i> ) for Repair Parts and Special Tool Lists (RPSTL) and Supply Catalogs/Supply Manuals (SC/SM).	DATE
<b>TO:</b> ( <i>Forward to proponent of publication or form</i> ) ( <i>Include ZIP Code</i> ) AMSTA-LC-LMPP/TECH PUBS, TACOM-RI 1 Rock Island Arsenal Rock Island, IL 61299-7630						<b>FROM:</b> ( <i>Activity and location</i> ) ( <i>Include ZIP Code</i> )	
<b>PART I - ALL PUBLICATIONS (EXCEPT RPSTL AND SC/SM) AND BLANK FORMS</b>							
PUBLICATION/FORM NUMBER TM 10-3930-638-24						DATE 15 July 2008	TITLE Field Maintenance (Including Unit, DS, and GS) for Truck, Forklift, DED, Pneumatic Tire, Articulated Frame Steer, 4000 lb Capacity Rough Terrain, Army Model MHE 237
ITEM	PAGE	PARA-	LINE	FIGURE NO.	TABLE	RECOMMENDED CHANGES AND REASON	
TYPED NAME, GRADE OR TITLE						TELEPHONE EXCHANGE/AUTOVON, PLUS EXTENSION	
						SIGNATURE	

<b>TO:</b> <i>(Forward direct to addressee listed in publication)</i> AMSTA-LC-LMPP/TECH PUBS, TACOM-RI 1 Rock Island Arsenal Rock Island, IL 61299-7630	<b>FROM:</b> <i>(Activity and location) (Include ZIP Code)</i>	<b>DATE</b>
---	--	-------------

**PART II - REPAIR PARTS AND SPECIAL TOOL LISTS AND SUPPLY CATALOGS/SUPPLY MANUALS**

<b>PUBLICATION NUMBER</b> TM 10-3930-638-24	<b>DATE</b> 15 July 2008	<b>TITLE</b> Field Maintenance (Including Unit, DS, and GS) for Truck, Forklift, DED, Pneumatic Tire, Articulated Frame Steer, 4000 lb Capacity Rough Terrain, Army Model MHE 237
--	-----------------------------	--

PAGE NO.	COLM NO.	LINE NO.	NATIONAL STOCK NUMBER	REFERENCE NO.	FIGURE NO.	ITEM NO.	TOTAL NO. OF MAJOR ITEMS SUPPORTED	RECOMMENDED ACTION

**PART III - REMARKS** *(Any general remarks or recommendations, or suggestions for improvement of publications and blank forms. Additional blank sheets may be used if more space is needed.)*

TYPED NAME, GRADE OR TITLE	TELEPHONE EXCHANGE/AUTOVON, PLUS EXTENSION	SIGNATURE
----------------------------	--	-----------



By Order of the Secretary of the Army:

GEORGE W. CASEY, JR.  
*General, United States Army*  
*Chief of Staff*

Official:

  
JOYCE E. MORROW  
*Administrative Assistant to the*  
*Secretary of the Army*  
0818201

**DISTRIBUTION:** To be distributed in accordance with the initial distribution requirements for IDN: 252162, requirements for TM 10-3930-638-24.



## THE METRIC SYSTEM AND EQUIVALENTS

<p><b>Linear Measure</b></p> <p>1 Centimeter = 10 Millimeters = 0.01 Meters = 0.3937 Inches          1 Meter = 100 Centimeters = 1000 Millimeters = 39.37 Inches          1 Kilometer = 1000 Meters = 0.621 Miles</p> <p><b>Weights</b></p> <p>1 Gram = 0.001 Kilograms = 1000 Milligrams = 0.035 Ounces          1 Kilogram = 1000 Grams = 2.2 Pounds          1 Metric Ton = 1000 Kilograms = 1 Megagram = 1.1 Short Tons</p> <p><b>Liquid Measure</b></p> <p>1 Milliliter = 0.001 Liters = 0.0338 Fluid Ounces          1 Liter = 1000 Milliliters = 33.82 Fluid Ounces</p>	<p><b>Square Measure</b></p> <p>1 Sq Centimeter = 100 Sq Millimeters = 0.155 Sq Inches          1 Sq Meter = 10,000 Sq Centimeters = 10.76 Sq Feet          1 Sq Kilometer = 1,000,000 Sq Meters = 0.386 Sq Miles</p> <p><b>Cubic Measure</b></p> <p>1 Cu Centimeter = 1,000 Cu Millimeters = 0.06 Cu Inches          1 Cu Meter = 1,000,000 Cu Centimeters = 35.31 Cu Feet</p> <p><b>Temperature</b></p> <p><math>5/9 (^{\circ}\text{F} - 32) = ^{\circ}\text{C}</math>          212° Fahrenheit is equivalent to 100° Celsius          90° Fahrenheit is equivalent to 32.2° Celsius          32° Fahrenheit is equivalent to 0° Celsius  <math>9/5 \text{ C}^{\circ} + 32 = \text{F}^{\circ}</math></p>
--	--

## APPROXIMATE CONVERSION FACTORS

To Change	To	Multiply By
Inches	Centimeters	2.540
Feet	Meters	0.305
Yards	Meters	0.914
Miles	Kilometers	1.609
Sq Inches	Sq Centimeters	6.451
Sq Feet	Sq Meters	0.093
Sq Yards	Sq Meters	0.836
Sq Miles	Sq Kilometers	2.590
Acres	Sq Hectometers	0.405
Cubic Feet	Cubic Meters	0.028
Cubic Yards	Cubic Meters	0.765
Fluid Ounces	Milliliters	29.573
Pints	Liters	0.473
Quarts	Liters	0.946
Gallons	Liters	3.785
Ounces	Grams	28.349
Pounds	Kilograms	0.454
Short Tons	Metric Tons	0.907
Pound-Feet	Newton-Meters	1.356
Pounds per Sq Inch	Kilopascals	6.895
Miles per Gallon	Kilometers per Liter	0.425
Miles per Hour	Kilometers per Hour	1.609

To Change	To	Multiply By
Centimeters	Inches	0.394
Meters	Feet	3.280
Meters	Yards	1.094
Kilometers	Miles	0.621
Sq Centimeters	Sq Inches	0.155
Sq Meters	Sq Feet	10.764
Sq Meters	Sq Yards	1.196
Sq Kilometers	Sq Miles	0.386
Sq Hectometers	Acres	2.471
Cubic Meters	Cubic Feet	35.315
Cubic Meters	Cubic Yards	1.308
Milliliters	Fluid Ounces	0.034
Liters	Pints	2.113
Liters	Quarts	1.057
Liters	Gallons	0.264
Grams	Ounces	0.035
Kilograms	Pounds	2.205
Metric Tons	Short Tons	1.102
Newton-Meters	Pound-Feet	0.738
Kilopascals	Pounds per Sq Inch	0.145
Kilometers per Liter	Miles per Gallon	2.354
Kilometers per Hour	Miles per Hour	0.621



This fine document...

Was brought to you by me:



## [Liberated Manuals -- free army and government manuals](#)

Why do I do it? I am tired of sleazy CD-ROM sellers, who take publicly available information, slap “watermarks” and other junk on it, and sell it. Those masters of search engine manipulation make sure that their sites that sell free information, come up first in search engines. They did not create it... They did not even scan it... Why should they get your money? Why are not letting you give those free manuals to your friends?

I am setting this document FREE. This document was made by the US Government and is NOT protected by Copyright. Feel free to share, republish, sell and so on.

I am not asking you for donations, fees or handouts. If you can, please provide a link to [liberatedmanuals.com](http://liberatedmanuals.com), so that free manuals come up first in search engines:

<A HREF=<http://www.liberatedmanuals.com/>>Free Military and Government Manuals</A>

- Sincerely  
Igor Chudov  
<http://igor.chudov.com/>
- [Chicago Machinery Movers](#)