

NOTE
ALL GROUND LUGS
GO TO GROUND POST
AT BATTERY

LEGEND:

2 PIN WEATHER PACK CONNECTOR	CONTROLLER	RELAY N.O. CONTACTS	RING TERMINAL GRD TO CHASIS
MOLDED CONNECTOR	DIODE	MIL SPEC CONNECTOR	MOTOR
			INTERNAL CHASIS GRD

NOTE:
THIS ILLUSTRATION IS A SCHEMATIC ONLY AND IS
MEANT TO SHOW POINT TO POINT CONNECTION.
THIS ILLUSTRATION DOES NOT SHOW PHYSICAL
LOCATION OF COMPONENTS OR ROUTING OF
CABLES.

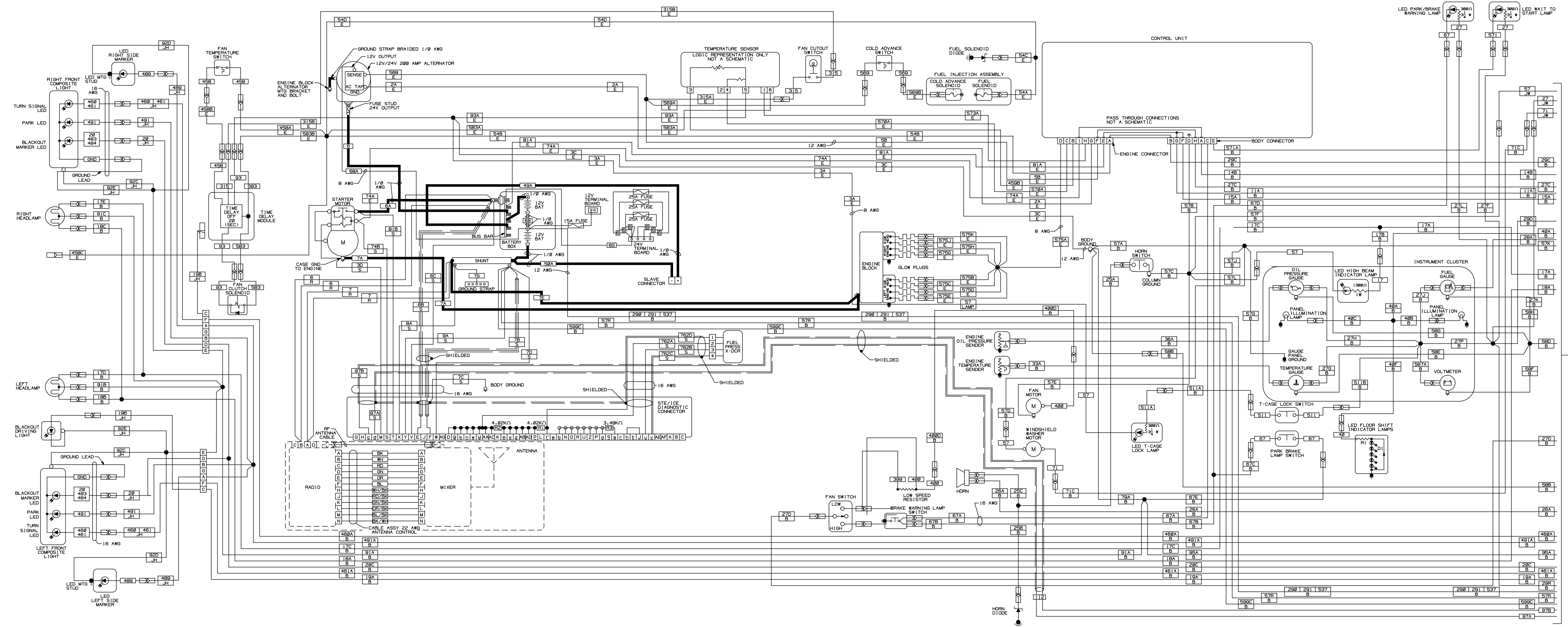

CONTINUED ON SH1

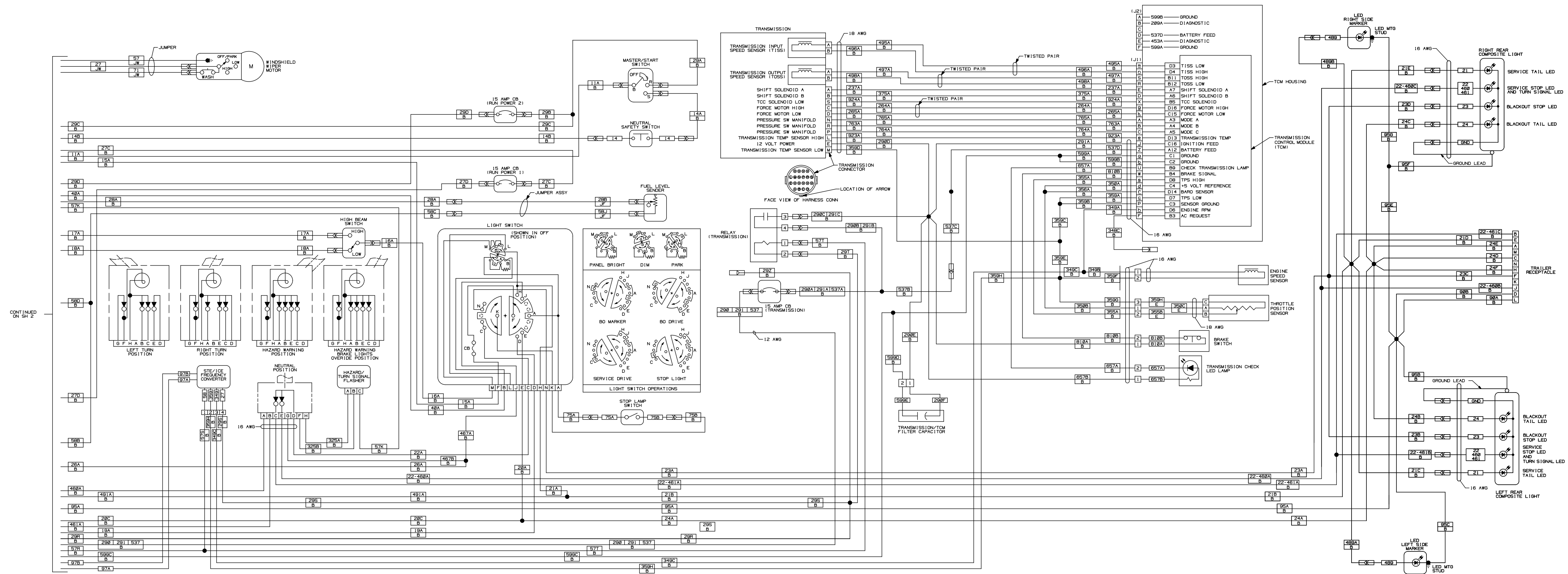

CONTINUED ON SH 2

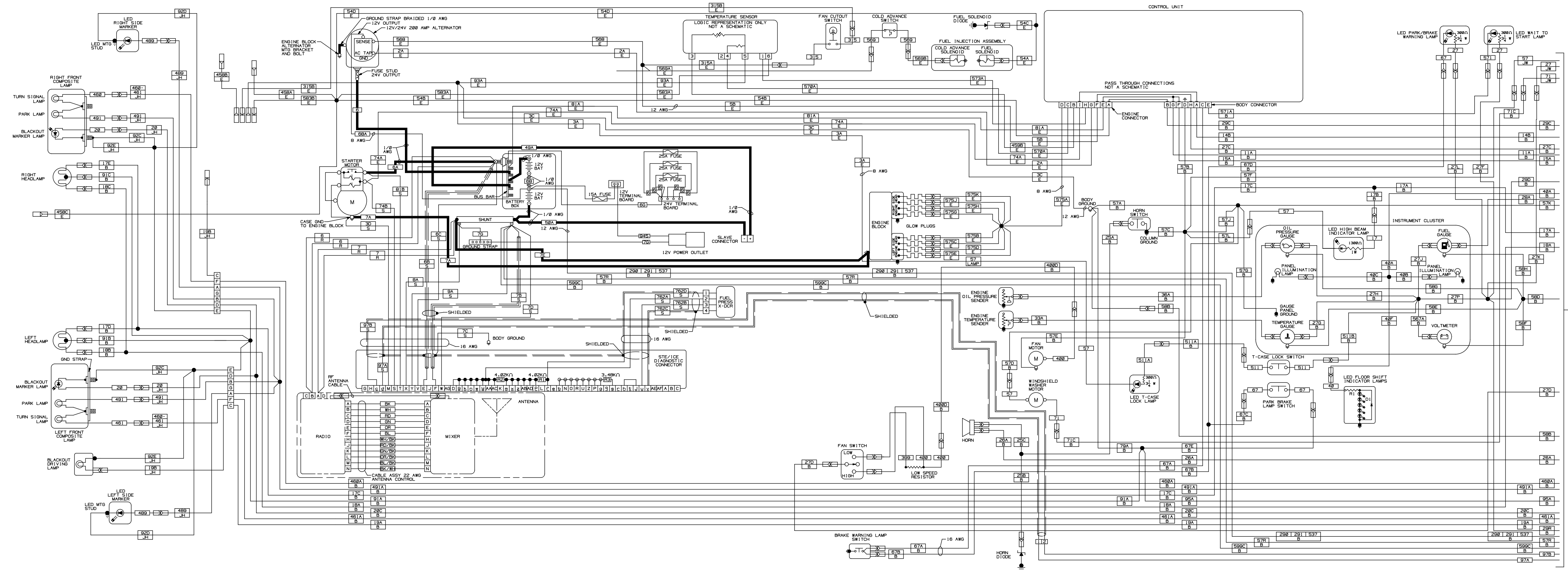

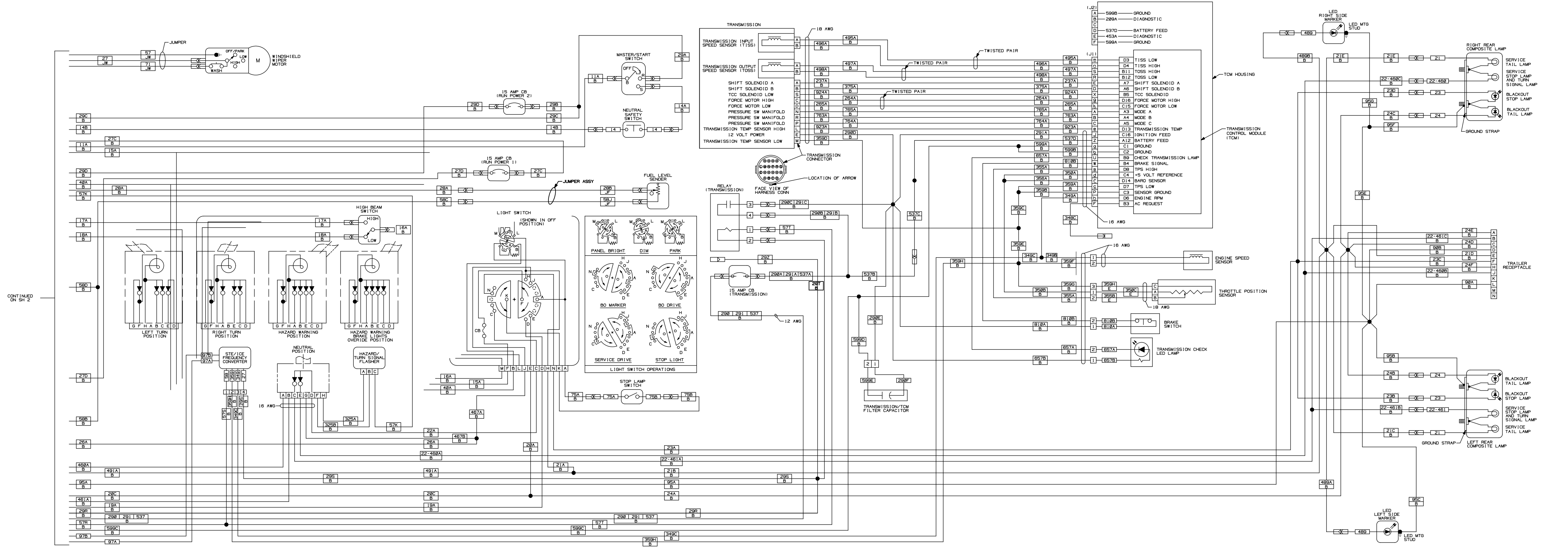

CONTINUED ON SH 2

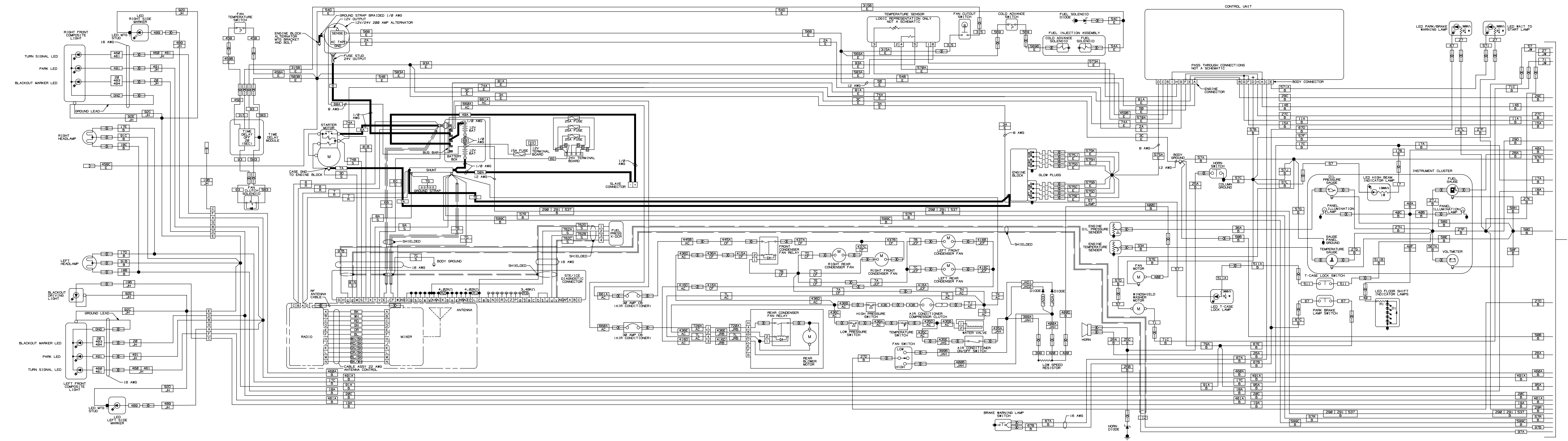

CONTINUED ON SH-1

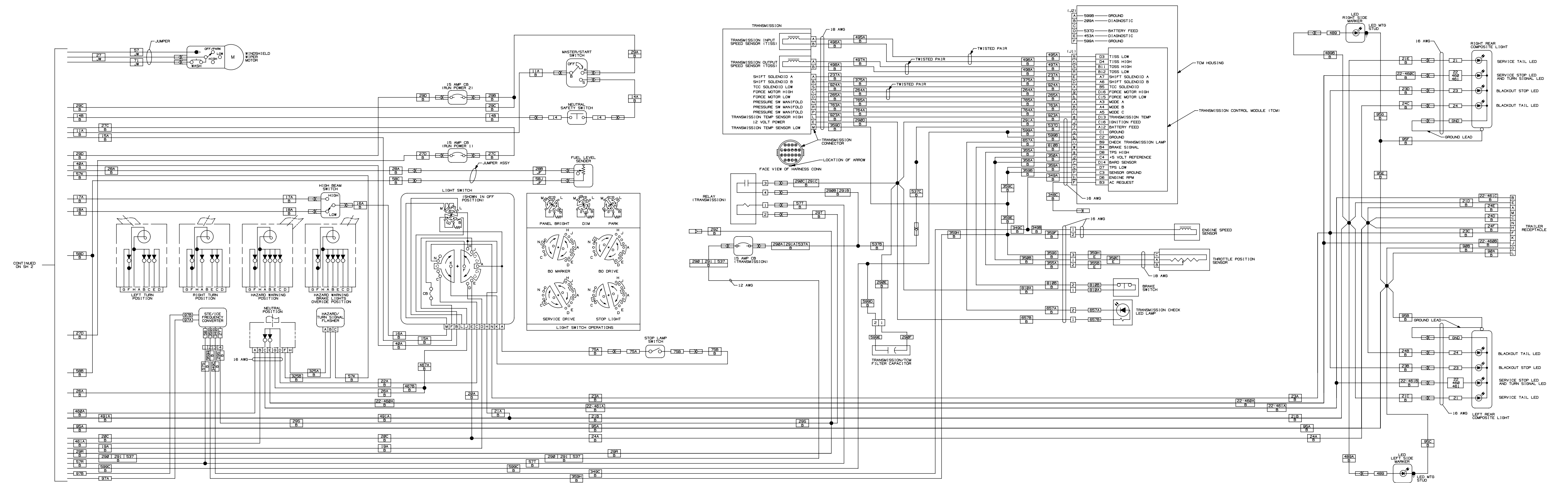

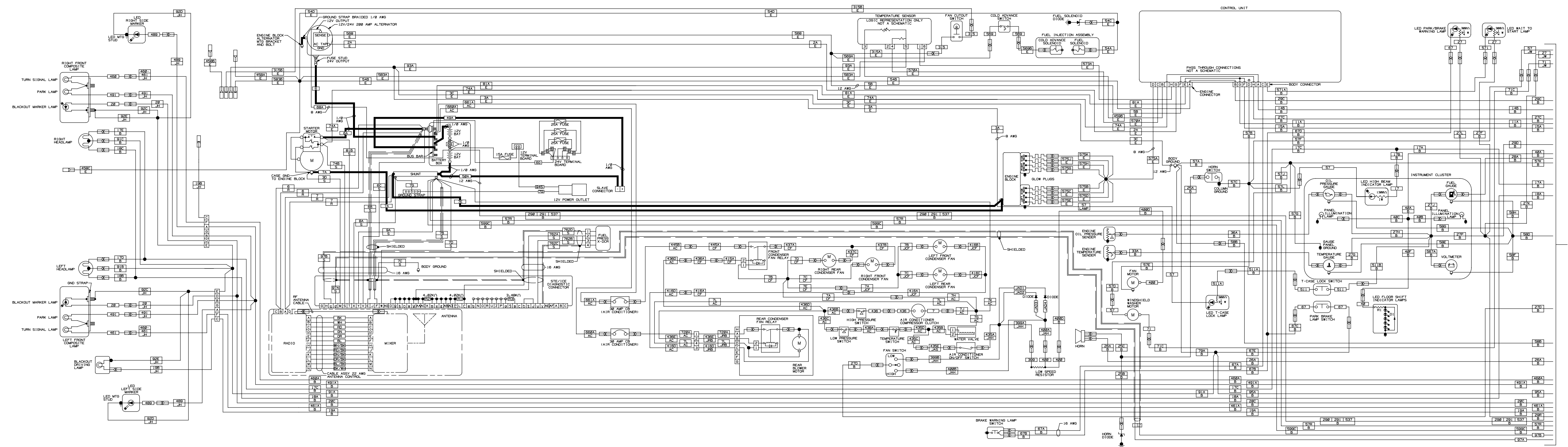

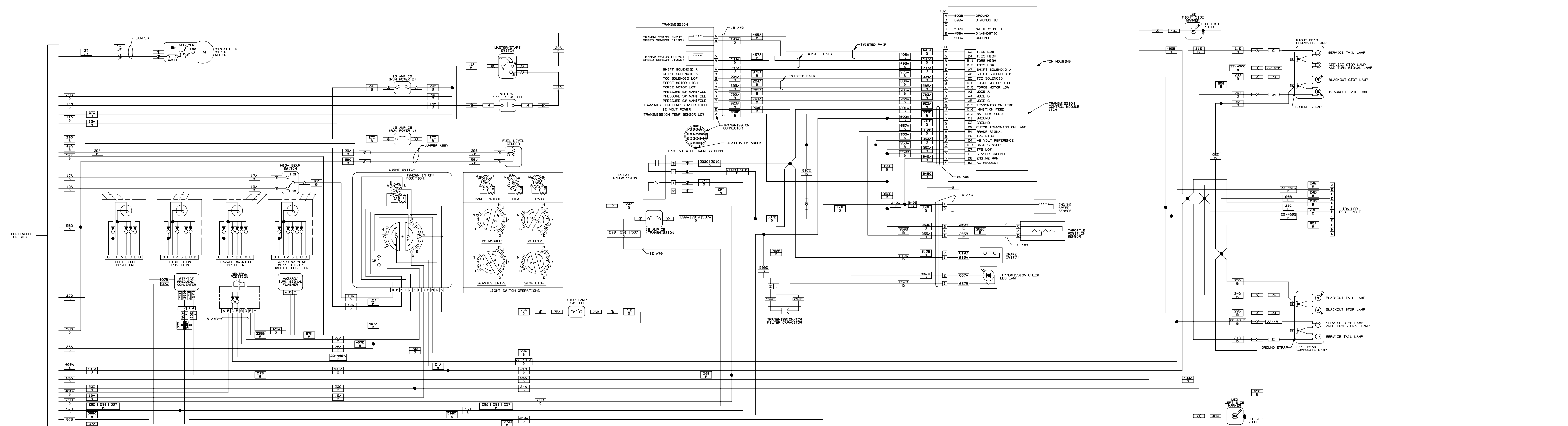

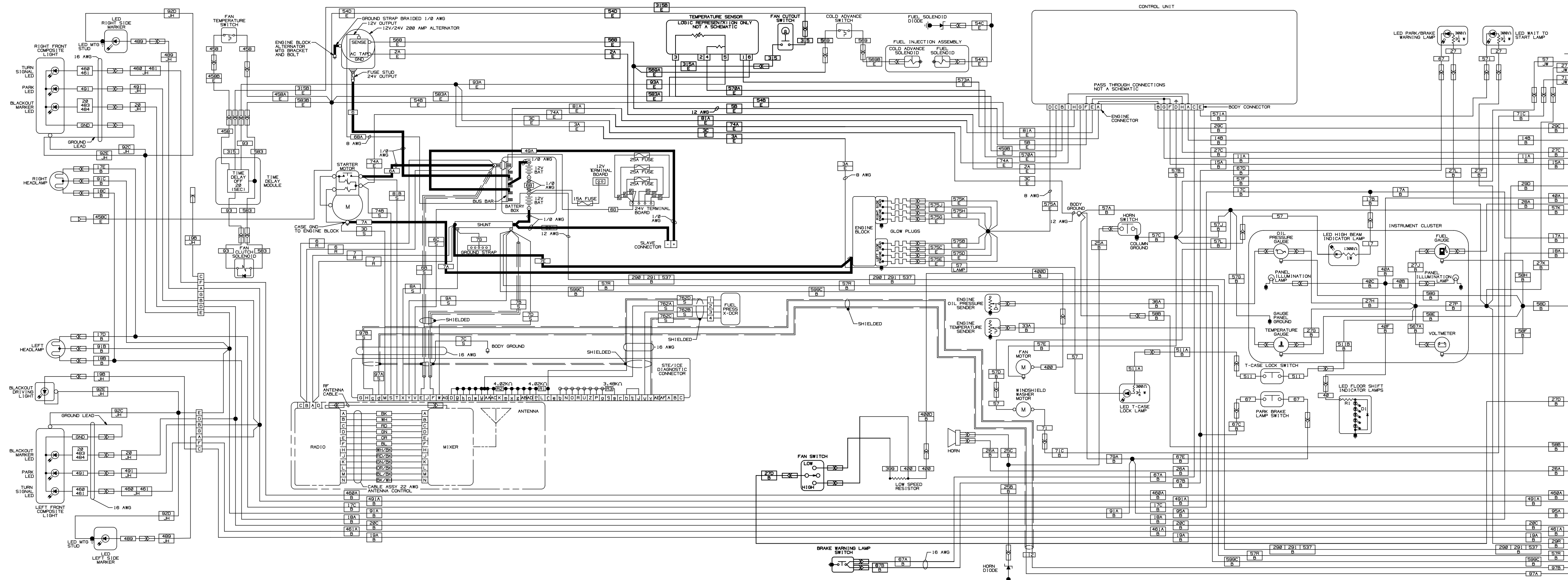

CONTINUED ON SH 1

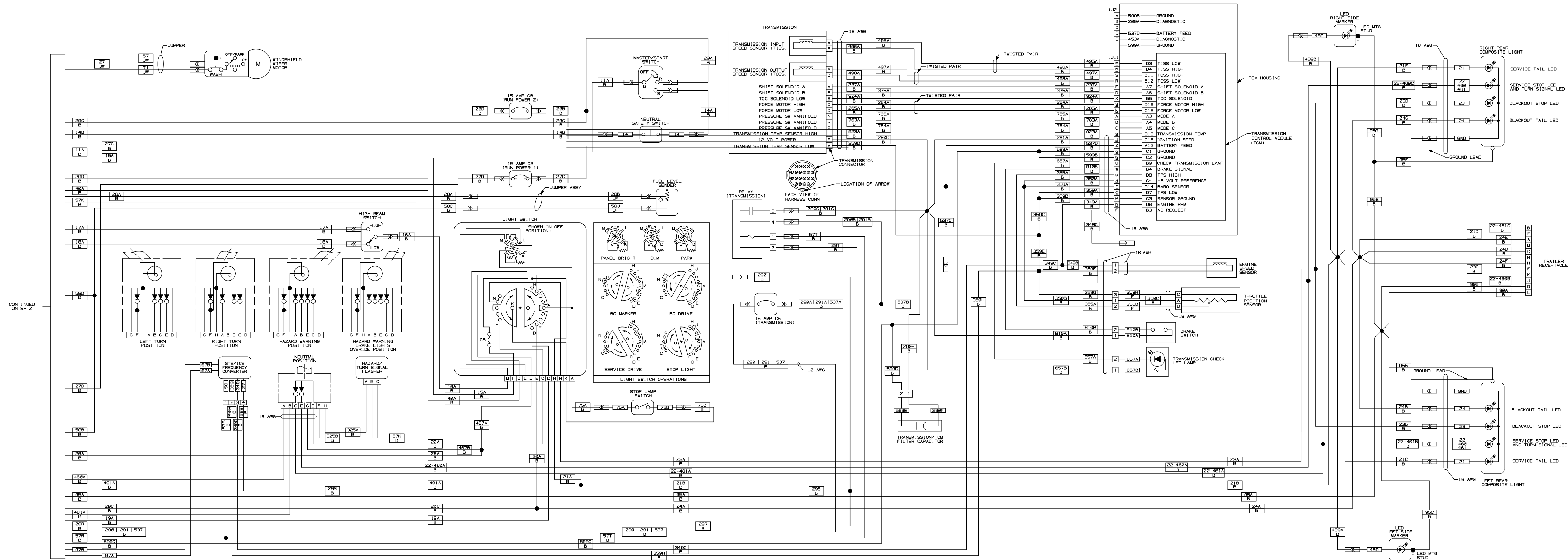

CONTINUED ON SH 2

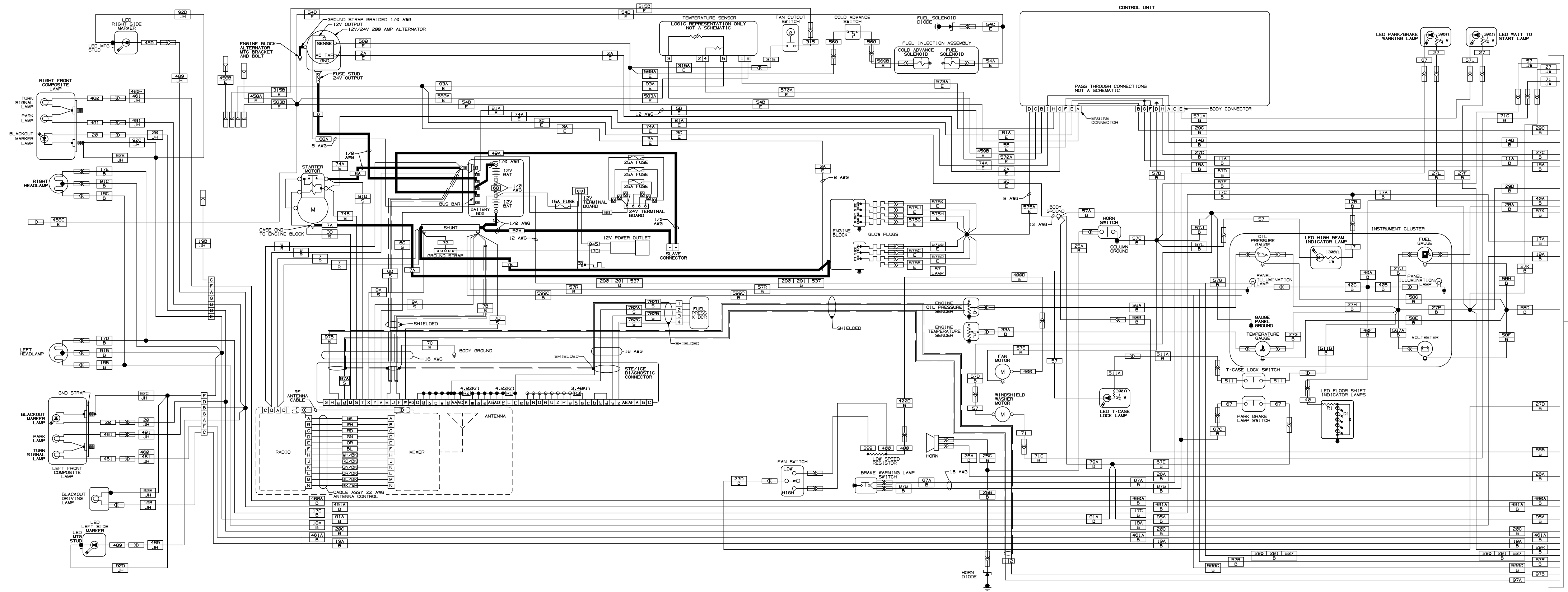

CONTINUED ON SH 1

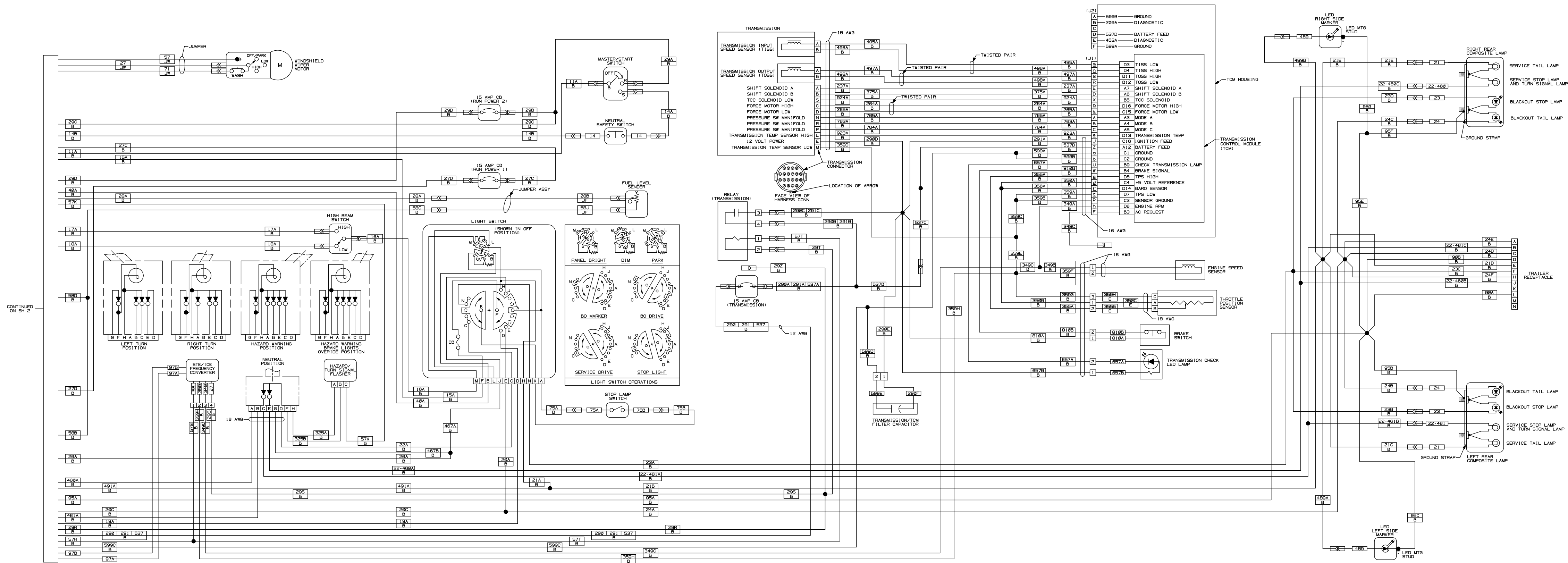

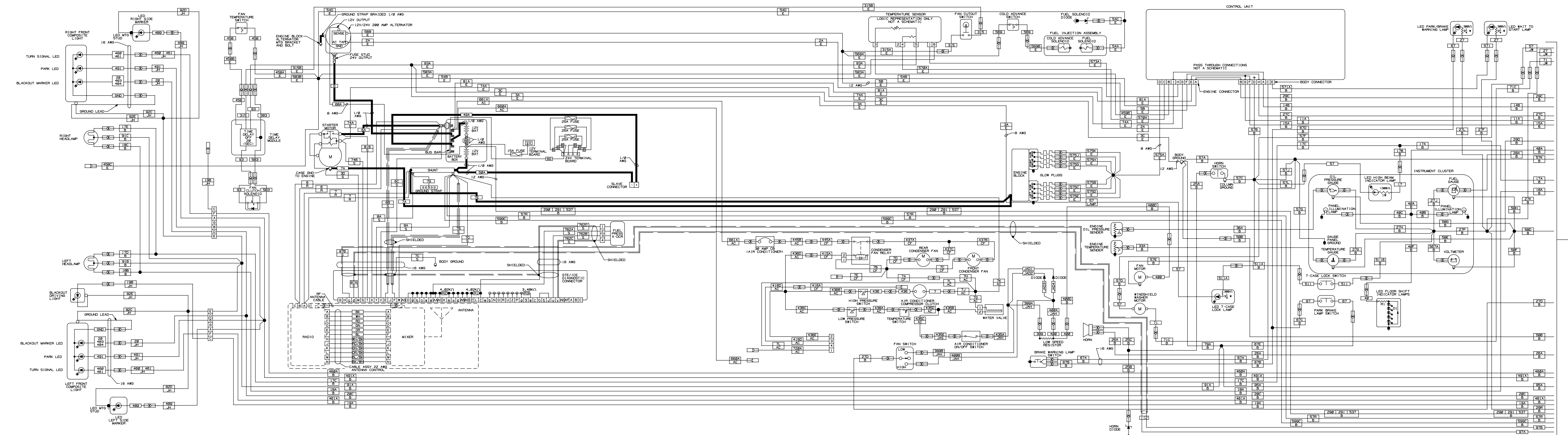

CONTINUED ON SH 1

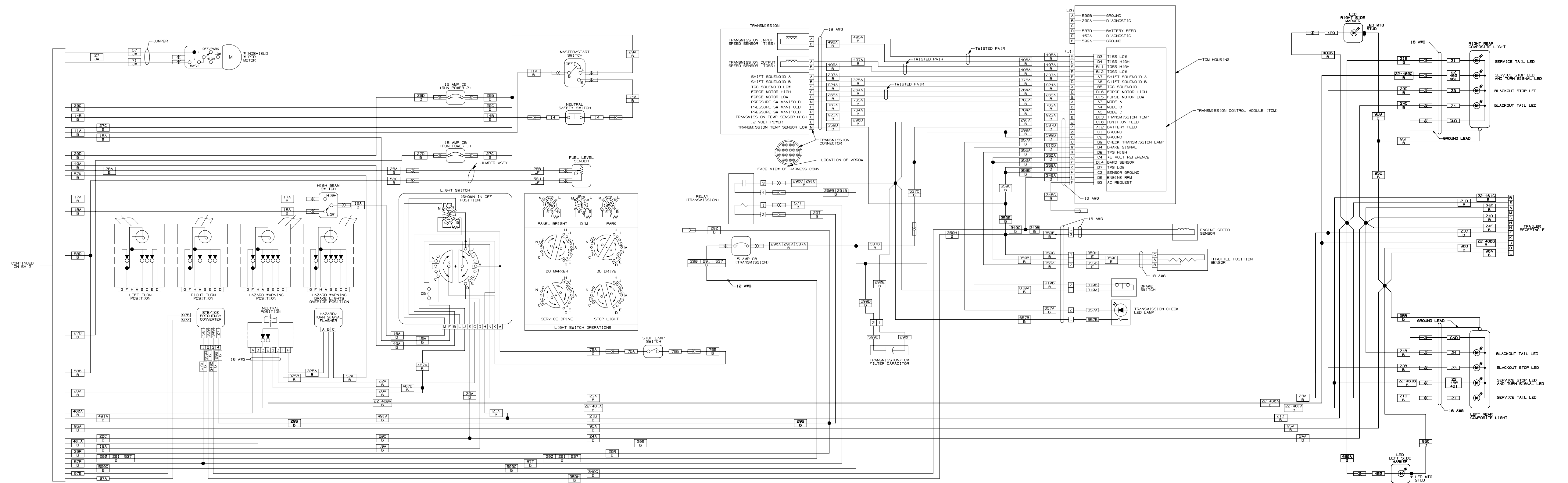

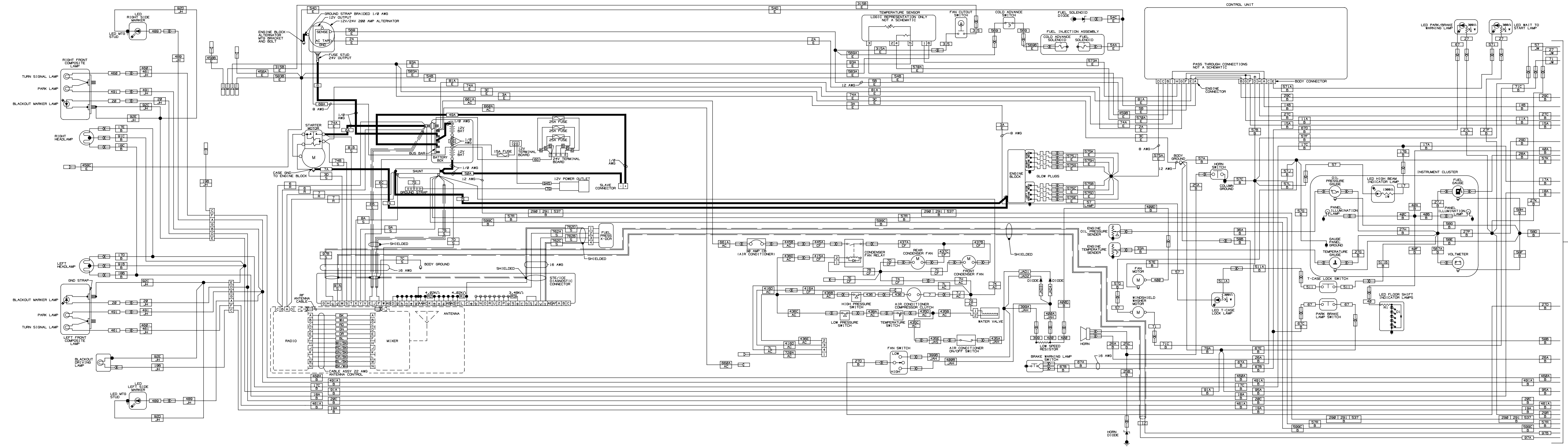

CONTINUED ON SH-1

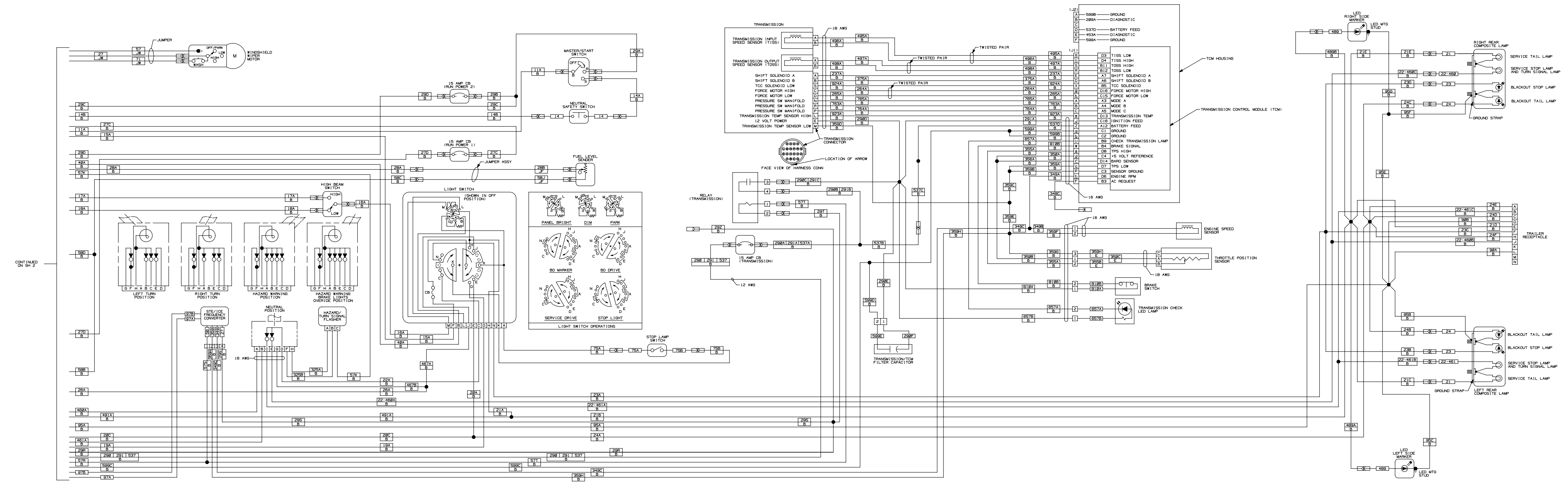

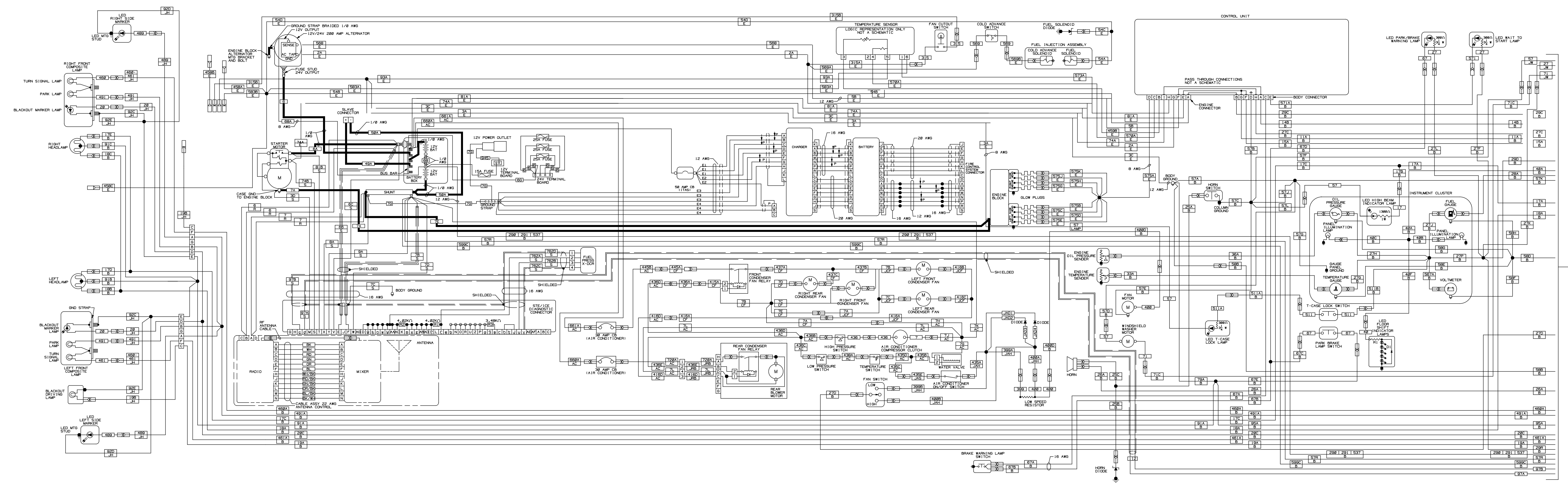

CONTINUED ON SH 1

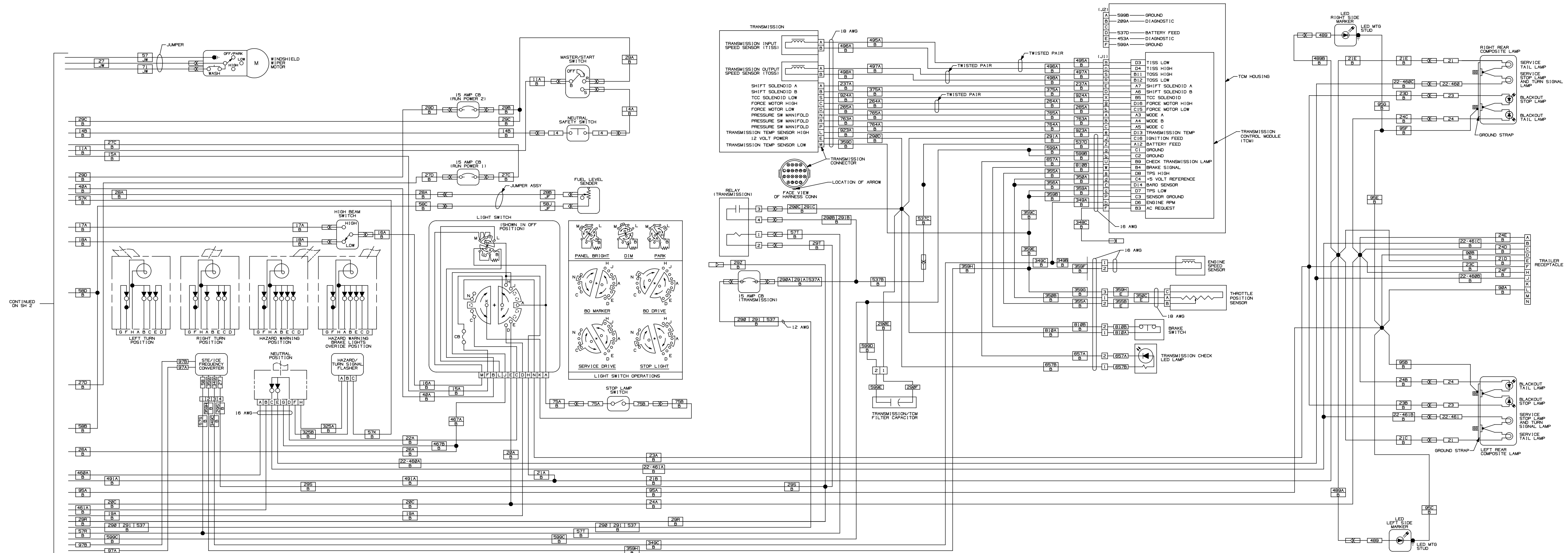

CONTINUED ON SH 2