

ROUTINE

MWO effective date is 1 June 1996 and completion date is 31 May 2007.

MWO 9-2320-280-35-2

MODIFICATION WORK ORDER

MODIFICATION OF THE HIGH-MOBILITY MULTIPURPOSE WHEELED VEHICLE M998 SERIES

3-POINT SEATBELT RESTRAINT SYSTEM FOR BASIC ARMORED AND NON-ARMORED VEHICLES

NOMENCLATURE	NSN
Truck, Utility: Cargo/Troop Carrier M998	2320-01-107-7155 (EIC: BBD)
M1038	2320-01-107-7156 (EIC: BBE)
Truck, Utility: S250 Shelter Carrier M1037	2320-01-146-7193 (EIC: BBK)
M1042	2320-01-146-7189
Truck, Ambulance: 2-Litter, Soft-Top M1035	2310-01-146-7194
Truck, Utility: TOW Carrier, Armored M966	2320-01-107-7153 (EIC: BBC)
M1036	2320-01-107-7154 (EIC: BBH)
Truck, Utility: Armament Carrier, Armored M1025	2320-01-128-9551 (EIC: BBF)
M1026	2320-01-128-9552 (EIC: BBG)

Headquarters, Department of the Army, Washington, D.C.

1 June 1996

REPORTING OF ERRORS AND RECOMMENDING IMPROVEMENTS

You can help improve this publication. If you find any mistakes or if you know of a way to improve the procedures, please let us know. Submit your DA Form 2028 (Recommended Changes to Equipment Technical Publications), through the Internet, on the Army Electronic Product Support (AEPS) website. The Internet address is <https://aeeps.ria.army.mil>. The DA Form 2028 is located under the Public Applications section in the AEPS Public Home Page. Fill out the form and click on SUBMIT. Using this form on the AEPS will enable us to respond quicker to your comments and better manage the DA Form 2028 program. You may also mail, fax or E-mail your letter, DA Form 2028 direct to: AMSTA-LC-LMIT / TECH Pubs, TACOM-RI, 1 Rock Island Arsenal, Rock Island, IL 61299-7630. The email address is TACOM-TECH-PUBS@ria.army.mil. The fax number is DSN 793-0726 or Commercial (309) 782-0726.

APPROVED FOR PUBLIC RELEASE; DISTRIBUTION IS UNLIMITED.

CHANGE

NO. 2

HEADQUARTERS
DEPARTMENT OF THE ARMY
Washington, D.C., 31 OCTOBER 2005

MODIFICATION WORK ORDER

MODIFICATION OF THE HIGH-MOBILITY MULTIPURPOSE WHEELED VEHICLE M998 SERIES

3-POINT SEATBELT RESTRAINT SYSTEM FOR BASIC ARMORED AND NON-ARMORED VEHICLES

NOMENCLATURE	NSN
Truck, Utility: Cargo/Troop Carrier	
M998	2320-01-107-7155 (EIC: BBD)
M1038	2320-01-107-7156 (EIC: BBE)
Truck, Utility: S250 Shelter Carrier	
M1037	2320-01-146-7193 (EIC: BBK)
M1042	2320-01-146-7189
Truck, Ambulance: 2-Litter, Soft-Top	
M1035	2310-01-146-7194
Truck, Utility: TOW Carrier, Armored	
M966	2320-01-107-7153 (EIC: BBC)
M1036	2320-01-107-7154 (EIC: BBH)
Truck, Utility: Armament Carrier, Armored	
M1025	2320-01-128-9551 (EIC: BBF)
M1026	2320-01-128-9552 (EIC: BBG)

MWO 9-2320-280-35-2, 1 June 1996, is changed as follows:

1. Remove old pages and insert new pages as indicated below.
2. New or changed material is indicated by a vertical bar in the margin of the page.

Remove pages

1 through 10
13 through 26
29 and 30
Figures 6 and 7
Figures 10 and 11
Figures 18 through 21
Figures 24 and 25
Figures 28 through 31
Figures 36 and 37
Figures 40 through 45
Figures 54 and 55
Figures 64 and 65
Figures 66 and 67

Insert pages

1 through 10
13 through 26
29 and 30
Figures 6 and 7
Figures 10 and 11
Figures 18 through 21
Figures 24 and 25
Figures 28 through 31
Figures 36 and 37
Figures 40 through 45
Figures 54 and 55
Figures 64 and 65
Figures 66 and 67

3. File this change sheet in front of the publication for reference purposes.

Approved for public release; distribution is unlimited.

By Order of the Secretary of the Army:

PETER J. SCHOOMAKER
General, United States Army
Chief of Staff

Official:

SANDRA R. RILEY
Administrative Assistant to the
Secretary of the Army
0524302

DISTRIBUTION: To be distributed in accordance with the initial distribution requirements for IDN: 381009, requirements for MWO 9-2320-280-35-2.

CHANGE

NO.1

HEADQUARTERS
DEPARTMENT OF THE ARMY
Washington D.C., 29 September 2000

MODIFICATION WORK ORDER

MODIFICATION OF THE HIGH MOBILITY MULTI-PURPOSE WHEELED VEHICLE M998 SERIES

3-POINT SEATBELT RESTRAINT SYSTEM FOR BASIC ARMORED AND NON-ARMORED VEHICLES

NOMENCLATURE	NSN
Truck, Utility: Cargo/Troop Carrier M998	2320-01-107-7155 (EIC: BBD)
M1038	2320-01-107-7156 (EIC: BBE)
Truck, Utility: S250 Shelter Carrier M1037	2320-01-146-7193 (EIC: BBK)
M1042	2320-01-146-7189
Truck, Ambulance: 2-Litter, Soft-Top M1035	2310-01-146-7194
Truck, Utility: TOW Carrier, Armored M966	2320-01-107-7153 (EIC: BBC)
M1036	2320-01-107-7154 (EIC: BBH)
Truck, Utility: Armament Carrier, Armored M1025	2320-01-128-9551 (EIC: BBF)
M1026	2320-01-128-9552 (EIC: BBG)

MWO 9-2320-280-35-2, 1 June 1996, is changed as follows:

1. The completion date for this MWO has been extended to 31 May 2005.
2. Remove old pages and insert new pages as indicated below.
3. New or changed material is indicated by a vertical bar in the margin of the page.

Remove pages

1 through 4

Insert pages

1 through 4

4. File this change sheet in front of the publication for reference purposes.

APPROVED FOR PUBLIC RELEASE; DISTRIBUTION IS UNLIMITED.

By Order of the Secretary of the Army:

ERIC K. SHINSEKI
General, United States Army
Chief of Staff

Official:

JOEL B. HUDSON
Administrative Assistant to the
Secretary of the Army

0020315

DISTRIBUTION:

To be distributed in accordance with the initial distribution number (IDN) 381009, requirements for MWO 9-2320-280-35-2.

1. PURPOSE.

This modification provides instructions for installing 3-Point Seatbelts on the front and rear seats of selected Basic Armored and Non-Armored HMMWV models. The 3-Point Seatbelt is a safer and more effective restraint system than the 2-Point Seatbelt System.

2. PRIORITY.

This modification is classified as ROUTINE.

3. END ITEM TO BE MODIFIED.

a. Selected vehicles as identified by serial numbers 1 through 99,999, inclusively:

NOMENCLATURE	NSN	PART NO.	CAGEC	MODEL NO.
Truck, Utility: Cargo/Troop Carrier, 1-1/4 ton, 4x4	2320-01-107-7155	8750057	19207	M998
	2320-01-107-7156	8750058	19207	M1038
Truck, Utility: S250 Shelter Carrier, 1-1/4 ton, 4x4	2320-01-146-7193	8750117	19207	M1037
	2320-01-146-7187	8750124	19207	M1042
Truck, Ambulance: 2-Litter Soft-top, 1-1/4 ton, 4x4	2310-01-146-7194	8750116	19207	M1035
Truck, Utility: TOW Carrier, Armored, 1-1/4 ton, 4x4	2320-01-107-7153	8750058	19207	M966
	2320-01-107-7154	8750050	19207	M1036
Truck, Utility: Armament Carrier, Armored, 1-1/4 ton, 4x4	2320-01-128-9551	8750124	19207	M1025
	2320-01-128-9552	8750123	19207	M1026

b. Vehicle National Stock Number (NSN) will not change as a result of this MWO.

4. MODULE TO BE MODIFIED.

Not applicable.

5. PARTS TO BE MODIFIED.

Not applicable.

6. APPLICATION.

a. Time Compliance Schedule: The effective date of this MWO is 1 June 1996 and its completion date is 31 May 2007.

b. The lowest level of maintenance authorized to apply the MWO is Direct Support. Initial Application of the MWO will be by Contract Maintenance Retrofit Teams.

c. Work force and man-hour requirements for application of this MWO to a single unit, end item, or system:

REQUIREMENTS (FRONT SEAT, NON-ARMORED)	
WORK FORCE/SKILLS	MAN-HOURS
Two-Wheeled Vehicle Mechanics (MOS 63W) or equivalent	7.5

Total man-hours required for a single application of this section of the MWO is 15 hours.

REQUIREMENTS (REAR SEAT, NON-ARMORED)

WORK FORCE/SKILLS**MAN-HOURS**

Two-Wheeled Vehicle Mechanics (MOS 63W) or equivalent	2.5
--	-----

Total man-hours required for a single application of this section of the MWO is 5 hours.

REQUIREMENTS (FRONT AND REAR SEAT, BASIC ARMORED)

WORK FORCE/SKILLS**MAN-HOURS**

Two-Wheeled Vehicle Mechanics (MOS 63W) or equivalent	16
--	----

Total man-hours required for a single application of this section of the MWO is 32 hours.

7. TECHNICAL PUBLICATIONS AFFECTED/CHANGED AS A RESULT OF THE MWO.**Technical Publication****Date**

TM 9-2320-280-10	18 Jun 91
TM 9-2320-280-20	19 Jun 90
TM 9-2320-280-20P	22 Aug 91
TM 9-2320-280-34	20 Aug 91
TM 9-2320-280-34P	22 Aug 91

8. MWO KITS, PARTS, AND THEIR DISPOSITION.**8.1. FRONT SEAT, NON-ARMORED VEHICLE.**

a. The following kit is required to accomplish this modification. The security classification of this kit is unclassified. Shipping data is: weight 49.00 lbs; the kit measures 30.8 x 24.3 x 22.5 in.; its volume is 9.745 cu ft.

NSN	NOMENCLATURE	CAGEC	PART NO.
2540-01-387-4018	3-Point Seatbelt Retrofit Kit, Front Seat, Non-Armor	19207	57K0202

b. Non-Armor, Front Seat, 3-Point Seatbelt Retrofit Kit component Parts are listed below. This listing is used to inventory the Kit for completeness.

NSN	NOMENCLATURE	CAGEC	PART NO.	QTY.
9905-00-858-5682	Plate, Instruction, MWO	19207	10930014	1
2540-01-318-9229	Seat Assembly	19207	12338503-1	1
9905-01-203-9995	Decal	19207	12339101	1
5310-01-253-8437	Washer	19207	12340058	4
5306-01-315-7086	Bolt	19207	12340259-3	2
5306-01-316-1456	Bolt	19207	12340259-6	2
5306-01-316-2433	Bolt	19207	12340259-7	2
5310-01-286-6077	Washer	19207	12341856	2
5340-01-334-4241	Bracket Assembly	19207	12342372	2

NSN	NOMENCLATURE	CAGEC	PART NO.	QTY.
	Reinforcement	19207	12342379	1
	Reinforcement	19207	12342380	1
	Reinforcement Assembly	19207	12342385	1
	Reinforcement Assembly	19207	12342386	1
	Bracket Assembly	19207	12342683	2
	Reinforcement	19207	12342731	2
	"B" Pillar Padding Assembly	19207	12342954	1
	"B" Pillar Padding Assembly	19207	12342955	1
	Extension Assembly	19207	12342959	2
	Seatbelt	19207	12480530	2
5320-01-023-2529	Rivet	81349	M24243/1-A404	16
5315-00-814-3529	Pin	80205	MS16562-20	2
5305-00-253-5614	Screw, Drive	80205	MS21318-20	1
5310-00-809-4058	Washer	96906	MS27183-10	8
5310-00-241-6658	Nut	80205	M45913/4-5FG8Z	4
5320-01-135-7319	Rivet	80205	NAS9301BNS-6-03	42
5320-01-254-2547	Rivet	80205	NAS9303B-6-3	12
5305-01-016-5469	Screw	24617	186676	8
5310-01-119-1024	Washer	24617	2436162	16
5310-00-809-4085	Washer	24617	2436164	2
5306-01-244-7882	Screw	24617	454869	16
	Screw	24617	454970	2

c. Bulk and expendable material.

NSN	NOMENCLATURE	CAGEC	PART NO.	QTY.
8040-01-154-0038	Depend no-mix adhesive	05972	00206	2
7510-00-074-4961	Tape, pressure sensitive	81348	PPP-T-60	1

d. Parts Disposition. All parts removed and not reused during installation will be returned to

8.2. REAR SEAT, NON-ARMORED VEHICLE.

a. The following kit is required to accomplish this modification. The security classification of this kit is unclassified. Shipping data is: weight 13.00 lbs; the kit measures 14.3 x 10.3 x 7 in.; its volume is 0.597 cu ft.

NSN	NOMENCLATURE	CAGEC	PART NO.
2540-01-387-4036	3-Point Seatbelt Retrofit Kit, Rear Seat, Non-Armor	19207	57K0203

b. Non-Armor, Rear Seat, 3-Point Seatbelt Retrofit Kit components are listed below. The listing is used to inventory the kit for completeness.

NSN	NOMENCLATURE	CAGEC	PART NO.	QTY.
5306-01-315-7086	Bolt	19207	12340259-3	2
5306-01-315-7087	Bolt	19207	12340259-5	2
5306-01-316-1456	Bolt	19207	12340259-6	2
5310-01-286-0677	Washer	19207	12341856	6
5340-01-334-2887	Bracket, Retractor Mtg.	19207	12342374	2
	Rear Reinforcement Wheelhouse, L.H.	19207	12342375	1
	Rear Reinforcement Wheelhouse, R.H.	19207	12342376	1
	Seatbelt	19207	12480530	2
5320-01-029-8205	Rivet	81349	M24243/1-A405	4
5320-01-254-2547	Rivet	80205	NAS9303B-6-3	2
5320-01-135-7319	Rivet	80205	NAS9301BNS-6-03	9
5310-01-195-8828	Nut	24617	214442	2
5310-00-809-4085	Washer	24617	2436164	22
	Screw	24617	441426	2
5305-01-195-7052	Screw	24617	453124	2
5305-01-315-7066	Screw	24617	453719	4
	Screw	24617	454974	4
	Turnbutton	19207	549220	2
5310-01-315-3483	Nut	24617	9422300	14

c. Parts Disposition. All parts removed and not reused during installation will be returned to stock for disposition in accordance with AR 725-50.

8.3. FRONT AND REAR SEATS, BASIC ARMORED VEHICLE.

a. The following kit is required to accomplish this modification. The security classification of this kit is unclassified. Shipping data is: weight 62.00 lbs.; the kit measures 30.8 x 24.3 x 22.50 in.; its volume is 9.745 cu ft.

NSN	NOMENCLATURE	CAGEC	PART NO.
2540-01-387-1144	3-Point Seatbelt Retrofit Kit, Front and Rear Seats, Basic Armor	19207	57K0204

b. Basic Armor, Front and Rear Seats, 3-Point Seatbelt Retrofit Kit components are listed below. The listing is used to inventory the kit for completeness.

NSN	NOMENCLATURE	CAGEC	PART NO.	QTY.
9905-00-858-5682	Plate, Instruction, MWO	19207	10930014	1
2450-01-318-9229	Seat Assembly	19207	12338503-1	1
9905-01-203-9995	Decal	19207	12339101	1
5320-01-271-6357	Rivet	19207	12339355-1	4

NSN	NOMENCLATURE	CAGEC	PART NO.	QTY.
5340-01-120-7315	Plug	19207	12339361-1	4
	Plug	19207	12339361-2	2
	Trim Edge	19207	12340103-3	2
	Trim Edge	19207	12340103-4	2
5306-01-315-7086	Bolt	19207	12340259-3	2
5306-01-315-7088	Bolt	19207	12340259-4	2
5306-01-316-1456	Bolt	19207	12340259-6	4
5306-01-316-2433	Bolt	19207	12340259-7	2
1015-01-200-0869	Clamp	19207	12340487	1
	Bracket	19207	12340654-1	1
5310-01-286-6077	Washer	19207	12341856	12
5340-01-334-4241	Bracket Assembly	19207	12342372	2
	Reinforcement	19207	12342379	1
	Reinforcement	19207	12342380	1
5340-01-333-5851	Bracket, "D" Ring Mtg.	19207	12342381	2
	Reinforcement Assembly	19207	12342385	1
	Reinforcement Assembly	19207	12342386	1
5305-01-259-6322	Screw	19207	12342499-1	1
	Reinforcement Assembly	19207	12342722	2
	Bracket Assembly, Retractor Mtg.	19207	12342725	1
	Bracket Assembly, Retractor Mtg.	19207	12342726	1
	Reinforcement Rabbet	19207	12342731	2
2590-01-396-5007	Padding Assembly	19207	12446739	1
2590-01-394-9673	Padding Assembly	19207	12446741	1
2590-01-406-9821	Mount	19207	12446762	1
	Seatbelt	19207	12480530	4
5320-01-023-2529	Rivet	81349	M24243/1-A404	8
5315-00-814-3529	Pin	80205	MS16562-20	2
5305-00-253-5614	Screw, Drive	80205	MS21318-20	1
5340-00-091-3790	Clamp	80205	MS21333-75	3
5310-00-809-4058	Washer	96906	MS27183-10	8
5310-01-335-7092	Washer	24617	MS27183-11	8
5305-01-300-7444	Screw	96906	MS35206-246	7
5305-00-984-5678	Screw	96906	MS35206-298	8
5305-00-059-3659	Screw	80205	MS51958-63	2
5310-00-061-4650	Nut	81349	M45913/4-4CG8Z	4

NSN	NOMENCLATURE	CAGEC	PART NO.	QTY.
5310-00-721-5447	Nut	80205	NAS1022-N08	2
4320-01-135-7319	Rivet	80205	NAS9301BNS-6-03	42
5320-01-354-2547	Rivet	80205	NAS9303B-6-3	12
	Drill Bit, Type B, Class 2, 0.125	19207	GGG-D-751D	1
5305-01-016-5469	Screw	24617	186676	8
5310-01-102-3270	Washer	24617	2436161	12
5310-01-119-1024	Washer	24617	2436162	8
5310-00-809-4085	Washer	24617	2436164	12
5310-01-069-5243	Nut	24617	271163	5
5310-00-124-9265	Nut	24617	271169	2
5306-01-185-7052	Screw	24617	453124	4
5306-01-244-7882	Screw	24617	454869	8
5305-00-709-8282	Screw	24617	454970	2
	Screw	24617	454982	2
5310-01-066-6759	Nut	24617	9419454	6
5310-01-315-3403	Nut	24617	9422300	6
5310-01-213-4192	Washer	11862	9423534	4
5305-00-068-0508	Screw	05047	B1821BH025C075N	6
5305-00-071-2511	Screw	05047	B1821BH025C200N	2

c. Bulk and expendable material:

NSN	NOMENCLATURE	CAGEC	PART NO.	QTY.
8040-01-154-0038	Depend no-mix adhesive	05972	00206	2
7510-00-074-4961	Tape, pressure sensitive	81348	PPP-T-60	1

d. Parts Disposition. All parts removed and not reused during installation will be returned to stock for disposition in accordance with AR 725-50.

9. SPECIAL TOOLS; TOOL KITS; JIGS; TEST, MEASUREMENT, AND DIAGNOSTIC EQUIPMENT (TMDE); AND FIXTURES REQUIRED.

a. Hand tools necessary to apply MWO are contained in this tool kit:

NOMENCLATURE	NSN	CAGEC	SUPPLY CATALOGUE
Tool Kit, General Mechanic's	5180-00-177-7033	50980	SC 5180-90-CL-N26

b. Metal drilling equipment necessary to apply MWO is contained in this set:

NOMENCLATURE	NSN	CAGEC	SUPPLY CATALOGUE
Shop Equipment, Automotive Maintenance and Repair Common No. 1	4910-00-754-0654	19204	SC 4910-95-CC-A74

c. Jig/Fixture Equipment necessary to apply MWO to Non-Armored Front Seat Vehicles are contained in this template kit:

NOMENCLATURE	NSN	CAGEC	PART NO.
Template Kit, 3-Point Seatbelt, Front Seat, Non-Armor	2540-01-387-5710	19207	57K0205

c.1. Non-Armor, Front Seat, 3-Point Seatbelt Template Kit component parts are listed below. The listing is used to inventory the kit for completeness.

NSN	NOMENCLATURE	CAGEC	PART NO.	QTY.
	Template	19207	12342723	1
	Template	19207	12342724	1
	Template	19207	12342729	1
	Template	19207	12342730	1
	Template	19207	12342732	1
	Template	19207	12342733	1
	Template	19207	12342734	1
	Template	19207	12342735	1

d. Jig/Fixture Equipment necessary to apply MWO to Non-Armored Rear Seat Vehicles are contained in this template kit:

NOMENCLATURE	NSN	CAGEC	PART NO.
Template Kit, 3-Point Seatbelt, Rear Seat, Non-Armor	2540-01-387-5835	19207	57K0206

d.1. Non-Armor, Rear Seat, 3-Point Seatbelt template kit component parts are listed below. The listing is used to inventory the kit for completeness.

NSN	NOMENCLATURE	CAGEC	PART NO.	QTY.
	Template	19207	12342727	1
	Template	19207	12342728	1
	Template	19207	12342736	1

e. Jig/Fixture Equipment necessary to apply MWO to Non-Armored Front and Rear Seats Vehicles are contained in this template kit:

NOMENCLATURE	NSN	CAGEC	PART NO.
Template Kit, 3-Point Seatbelt, Front and Rear Seats, Basic Armor		19207	57K0207

e.1. Basic Armor, Front and Rear Seats, 3-Point Seatbelt template kit component parts are listed below. The listing is used to inventory the kit for completeness.

NSN	NOMENCLATURE	CAGEC	PART NO.	QTY.
	Template	19207	12342723	1
	Template	19207	12342724	1

NSN	NOMENCLATURE	CAGEC	PART NO.	QTY.
	Template	19207	12342729	1
	Template	19207	12342730	1
	Template	19207	12342732	1
	Template	19207	12342733	1
	Template	19207	12342737	1
	Template	19207	12342738	1
	Template	19207	12342739	1
	Template	19207	12342740	1

10. MODIFICATION PROCEDURES.

10.1. FRONT SEAT, NON-ARMORED VEHICLE.

WARNING

All seatbelt anchor point hardware must be replaced with the new hardware provided in the kit to ensure adequate strength. Failure to do this may result in injury to personnel.

NOTE

Body side panels beneath the "B" pillar must be free of dents and/or body filler material to ensure structural rigidity when reinforcements are installed. Body side panels damaged or previously repaired must be replaced prior to installation of this kit.

a. VEHICLE PREPARATION.

- (1) Disconnect battery ground cable. (Refer to TM 9-2320-280-20.)
- (2) Remove fixed doors, if installed. (Refer to TM 9-2320-280-20.)
- (3) Remove cargo barrier, if installed. (Refer to TM 9-2320-280-20.)
- (4) Remove rear curtain, if installed. (Refer to TM 9-2320-280-20.)
- (5) Remove rear seat backs, if installed in stowed position. (Refer to TM 9-2320-280-20.)
- (6) Remove enclosure panels. (Refer to TM 9-2320-280-20.)
- (7) Remove driver's seat and seat back cushions. (Refer to TM 9-2320-280-20.)
- (8) Remove driver's seat frame. (Refer to TM 9-2320-280-20.)
- (9) Remove shelter, if installed. (Refer to TM 9-2320-280-20.)
- (10) Remove troop seats, if installed. (Refer to TM 9-2320-280-20.)
- (11) Remove companion seat back. (Refer to TM 9-2320-280-20.)
- (12) Remove front seatbelt assemblies. (Refer to TM 9-2320-280-20.)

b. LEFT RABBIT REINFORCEMENT INSTALLATION.

NOTE

It may be necessary to replace identification data plate if damaged during removal.

- (1) Mark an outline around identification data plate and driver's seat adjustment decal on left rabbit assembly as shown in figure 1.

(2) Remove identification data plate and driver's seat adjustment decal from left rabbet assembly as shown in figure 1.

(3) Remove four screws, washers, and bracket from left side body and "B" pillar as shown in figure 2.

NOTE

- Clamping devices are necessary during installation of reinforcement to left rabbet assembly.
- Ensure inside surface of rabbet assembly is free of foreign materials.
- Ensure edges of reinforcement are flush with "B" pillar and left side body prior to hole drilling.
- Upon completion of drilling, remove any sharp edges and burrs.

(4) Position 12342379 reinforcement to inside of left rabbet assembly and position 12342729 template to outside of left rabbet assembly. Using template, drill eleven 0.191-inch diameter holes through left rabbet assembly and reinforcement as shown in figure 3.

(5) Use 0.328-inch diameter drill bit to countersink holes on left rabbet assembly within marked outline from data plate and driver's seat adjustment decal as shown in figure 3.

(6) Apply 00206 part 1 activator to inside of left rabbet assembly as shown in figure 4.

(7) Apply 00206 part 2 adhesive to mating surface of reinforcement as shown in figure 5.

CAUTION

When installing reinforcement to rabbet assembly, use clamping devices to compress adhesives between surfaces and to eliminate any air pockets and gaps. Failure to do this may result in insufficient bonding.

NOTE

Use M7885/2-6-3 rivets in drilled holes which did not require countersinking and NAS9303B-6-3 rivets in countersunk holes drilled in left rabbet assembly.

(8) Install reinforcement to left rabbet assembly and secure with eleven (any combination) NAS9301BNS-6-03 or NAS9303B-6-3 rivets as shown in figure 6.

(9) Using existing holes for identification data plate on left rabbet assembly as a template, drill four 0.128-inch diameter holes through reinforcement as shown in figure 6.

(10) Install identification data plate to left rabbet assembly and secure with four M24243/1-A404 rivets as shown in figure 6.

(11) Remove backing material from 12339101 driver's seat adjustment decal and install to left rabbet assembly as shown in figure 6.

(12) Install existing bracket, four 186676 screws, and four MS27183-10 washers to left side body and "B" pillar as shown in figure 7.

c. LEFT BODY REINFORCEMENT INSTALLATION.

(1) Using 12342731 reinforcement, mark a centerline on exterior side of reinforcement and apply two layers of PPP-T-60 tape to interior side of reinforcement as shown in figure 8.

(2) Locate and mark a reference centerline on left side body and "B" pillar as shown in figure 9.

(3) Aline centerline on reinforcement to centerline on left side body and "B" pillar. Apply pressure to reinforcement to transfer rivet head locations onto tape as shown in figure 9.

(4) Using tape as a template, transfer rivet head locations by center punching tape on reinforcement and remove tape as shown in figure 9.

NOTE

Upon completion of all drilling, remove any sharp edges and burrs.

(5) Using marked locations on reinforcement, drill 0.406-inch diameter clearance holes for rivet heads as shown in figure 9.

(6) Locate, mark, and drill seven 0.125-inch diameter holes in reinforcement as shown in figure 10.

(7) Aline centerline on reinforcement to centerline on left side body and "B" pillar. Using reinforcement as a template, drill seven 0.191-inch diameter holes through reinforcement and in left side body as shown in figure 11.

(8) Apply 00206 part 1 activator to left side body and "B" pillar as shown in figure 12.

(9) Apply 00206 part 2 adhesive to mating surface of reinforcement as shown in figure 13.

(10) Install reinforcement to left side body and "B" pillar and secure with seven M7885/2-6-3 rivets as shown in figure 11.

(11) Drill three 0.191-inch diameter holes through reinforcement and left side body as shown in figure 11.

(12) Using holes in bottom of reinforcement, install three M7885/2-6-3 rivets through reinforcement and left side body as shown in figure 11.

d. RIGHT RABBIT REINFORCEMENT INSTALLATION.

NOTE

It may be necessary to replace weight and dimensional data plate if damaged during removal.

(1) Mark an outline around weight and dimensional data plate on right rabbit assembly as shown in figure 14.

(2) Remove weight and dimensional data plate from right rabbit assembly as shown in figure 14.

(3) Remove four screws, washers, and bracket from right side body and "B" pillar as shown in figure 2.

NOTE

- Clamping devices are necessary during installation of reinforcement to right rabbit assembly.
- Ensure inside surface of rabbit assembly is free of foreign materials.
- Ensure edges of reinforcement are flush with "B" pillar and right side body prior to hole drilling.
- Upon completion of drilling, remove any sharp edges and burrs.

(4) Position 12342380 reinforcement to inside of right rabbit assembly and position 12342730 template to outside of right rabbit assembly. Using template, drill eleven 0.191-inch diameter holes through right rabbit assembly and reinforcement as shown in figure 15.

(5) Use 0.328-inch diameter drill bit to countersink marked holes on right rabbit assembly within marked outline from weight and dimensional data plate as shown in figure 15.

- (6) Apply 00206 part 1 activator to inside of right rabbet assembly as shown in figure 16.
- (7) Apply 00206 part 2 adhesive to mating surface of reinforcement as shown in figure 17.

CAUTION

When installing reinforcement to rabbet assembly, use clamping devices to compress adhesive between surfaces and to eliminate any air pockets and gaps. Failure to do this may result in insufficient bonding.

NOTE

Use M7885/2-6-3 rivets in drilled holes which did not require countersinking and NAS9303B-6-3 rivets in countersunk holes drilled in right rabbet assembly.

- (8) Install reinforcement to right rabbet assembly and secure with eleven (any combination) M7885/2-6-3 or NAS9303B-6-3 rivets as shown in figure 18.
- (9) Using existing holes for weight and dimensional data plate on right rabbet assembly, drill four 0.128-inch diameter holes through right rabbet assembly and reinforcement as shown in figure 18.
- (10) Install weight and dimensional data plate to right rabbet assembly and secure with four M24243/1-A404 rivets as shown in figure 18.
- (11) Install existing bracket, four 186676 screws, and four MS27183-10 washers to right side of body and "B" pillar as shown in figure 7.

e. RIGHT BODY REINFORCEMENT INSTALLATION.

- (1) Using 12342731 reinforcement, mark a centerline on exterior side of reinforcement and apply two layers of PPP-T-60 tape to interior side of reinforcement as shown in figure 8.
- (2) Locate and mark a reference centerline on right side body and "B" pillar as shown in figure 9.
- (3) Aline centerline on reinforcement to centerline on right side body and "B" pillar. Apply pressure to reinforcement to transfer rivet head locations onto tape as shown in figure 9.
- (4) Using tape as a template, transfer rivet head locations by center punching tape on reinforcement and remove tape as shown in figure 9.

NOTE

Upon completion of all drilling, remove any sharp edges and burrs.

- (5) Using marked locations on reinforcement, drill 0.406-inch diameter clearance holes for rivet heads as shown in figure 9.
- (6) Locate, mark, and drill seven 0.125-inch diameter holes in reinforcement as shown in figure 10.
- (7) Aline centerline on reinforcement to centerline on right side body and "B" pillar. Using reinforcement as a template, drill seven 0.191-inch diameter holes through reinforcement and in right side body as shown in figure 11.
- (8) Apply 00206 part 1 activator to right side body and "B" pillar as shown in figure 12.
- (9) Apply 00206 part 2 adhesive to mating surface of reinforcement as shown in figure 13.
- (10) Install reinforcement to right side body and "B" pillar and secure with seven M7885/2-6-3 rivets as shown in figure 11.
- (11) Using existing three holes in bottom of reinforcement, drill three 0.191-inch diameter holes through reinforcement and right side body as shown in figure 11.

(12) Install three M7785/2-6-3 rivets through reinforcement and right side body as shown in figure 11.

f. LEFT TUNNEL REINFORCEMENT ASSEMBLY INSTALLATION.

(1) Remove screw, retainer, and insulation from left side tunnel as shown in figure 19.

(2) Remove rivet from left side tunnel as shown in figure 19.

(3) Position 12342723 template to left side tunnel and drill three 0.125-inch diameter holes as shown in figure 20.

(4) Enlarge hole drilled in step (3) to 0.468-inch diameter in left side tunnel as shown in figure 21.

NOTE

Ensure that release button on the buckle is positioned towards the tunnel.

(5) Position 12342386 reinforcement assembly to left side tunnel and secure with 12340058 washer, buckle (part of seatbelt assembly 12480530), and 12340259-3 bolt as shown in figure 21. Tighten bolt to 35-40 lb-ft 48-54 N•m).

(6) Enlarge two holes drilled in step (3) to 0.191-inch diameter through left side tunnel and drill through reinforcement assembly as shown in figure 21.

(7) Install two NAS9301/BNS-6-03 rivets through holes in left side tunnel and reinforcement assembly as shown in figure 21.

(8) Install existing insulation, retainer, and screw to left side tunnel as shown in figure 19.

g. RIGHT TUNNEL REINFORCEMENT ASSEMBLY INSTALLATION.

(1) Remove two screws, clamp, retainer, and insulation from right side tunnel as shown in figure 22.

(2) Remove two rivets from right side tunnel as shown in figure 22.

(3) Position 12342724 template to right side tunnel and drill three 0.125-inch diameter holes as shown in figure 23.

(4) Enlarge hole drilled in step (3) to 0.468-inch diameter in right side tunnel as shown in figure 24.

NOTE

Ensure that release button on the buckle is positioned towards the tunnel.

(5) Position 12342385 reinforcement assembly to right side tunnel and secure with 12340058 washer, buckle (part of seatbelt assembly 12480530), and 12340259-3 bolt as shown in figure 24. Tighten bolt to 35-40 lb-ft (48-54 N•m).

(6) Enlarge two holes drilled in step (3) to 0.191-inch diameter through right side tunnel and drill through reinforcement assembly as shown in figure 24.

(7) Install two NAS9031BNS-6-03 rivets through holes in right side tunnel and reinforcement assembly as shown in figure 24.

(8) Install existing insulation, retainer, clamp, and two screws to right side tunnel as shown in figure 22.

h. LEFT UPPER BRACKET ASSEMBLY INSTALLATION.

(1) If vehicle is equipped with a two-man soft-top, loosen turnbuttons and pull top assembly and rear curtain away from "B" pillar as shown in figure 25.

(2) Remove two screws, washers, and nuts from left side "B" pillar as shown in figure 25.

(3) Remove two rivets and turnbutton from left side "B" pillar as shown in figure 25.

- (4) Cut and remove section from flap of top assembly on left side as shown in figure 26.
- (5) Install 12342734 and 12342735 templates to left side "B" pillar and secure with existing two screws, and nuts as shown in figure 27.
- (6) Using two templates, drill four 0.125-inch diameter holes in left side "B" pillar as shown in figure 27.
- (7) Remove two screws, nuts, and templates from left side "B" pillar as shown in figure 27.
- (8) Enlarge four holes drilled in step (6) to 0.343-inch diameter as shown in figure 28.
- (9) Install existing two screws, washers, and M45913/4-5FG8Z nuts in left side "B" pillar as shown in figure 28.
- (10) Install 12342683 bracket assembly on left side "B" pillar and secure with four 454869 screws and 2436162 washers as shown in figure 28.
- (11) Install existing turnbutton on left side "B" pillar with two M24243/1-A404 rivets as shown in figure 28.

i. RIGHT UPPER BRACKET ASSEMBLY INSTALLATION.

- (1) If vehicle is equipped with a two-man soft-top, loosen turnbuttons and pull top assembly and rear curtain away from "B" pillar as shown in figure 25.
- (2) Remove two screws, washers, and nuts from right side "B" pillar as shown in figure 25.
- (3) Remove two rivets and turnbutton from right side of "B" pillar as shown in figure 25.
- (4) Cut and remove section from flap of top assembly on right side as shown in figure 26.
- (5) Install 12342734 and 12342735 templates to right side "B" pillar and secure with existing two screws and nuts as shown in figure 27.
- (6) Using two templates, drill four 0.125-inch diameter holes in right side "B" pillar as shown in figure 27.
- (7) Remove two screws, nuts, and templates from right side "B" pillar as shown in figure 27.
- (8) Enlarge four holes drilled in step (6) to 0.343-inch diameter as shown in figure 28.
- (9) Install existing two screws, washers, and M45913/4-5FG8Z nuts on right side "B" pillar as shown in figure 28.
- (10) Install 12342683 bracket assembly on right side "B" pillar and secure with four 454869 screws and 2436162 washers as shown in figure 28.
- (11) Install existing turnbutton on right side "B" pillar with two M24243/1-A404 rivets as shown in figure 28.

j. LEFT LOWER BRACKET ASSEMBLY INSTALLATION.

- (1) Remove two screws and footman loop from left side "B" beam as shown in figure 29.
- (2) Position 12342732 template on "B" pillar and "B" beam. Using template, drill two 0.125-inch diameter holes on "B" pillar as shown in figure 29.
- (3) Enlarge two holes drilled in step (2) to 0.343-inch diameter as shown in figure 30.
- (4) Position 12342733 template on "B" pillar and "B" beam. Using template, drill two 0.125-inch diameter holes in "B" pillar as shown in figure 29.
- (5) Enlarge two holes drilled in step (4) to 0.343-inch diameter as shown in figure 30.

(6) Install 12342372 bracket assembly to "B" pillar and secure with four 454869 screws and 2436162 washers as shown in figure 30.

(7) Install existing footman loop and two screws to left side "B" beam as shown in figure 29.

k. RIGHT LOWER BRACKET ASSEMBLY INSTALLATION.

(1) Remove footman loop and two screws from right side "B" beam as shown in figure 29.

(2) Position 12342732 template on "B" pillar and "B" beam. Using template, drill two 0.125-inch diameter holes in "B" pillar as shown in figure 29.

(3) Enlarge two holes drilled in step (2) to 0.343-inch diameter as shown in figure 30.

(4) Position 12342733 template on "B" pillar and "B" beam. Using template, drill two 0.125-inch diameter holes in "B" pillar as shown in figure 29.

(5) Enlarge two holes drilled in step (4) to 0.343-inch diameter as shown in figure 30.

(6) Install 12342372 bracket assembly to "B" pillar and secure with four 454869 screws and 2436162 washers as shown in figure 30.

(7) Install existing footman loop and two screws to right side "B" beam as shown in figure 29.

l. LEFT AND RIGHT SEATBELT ASSEMBLY INSTALLATION.

(1) Position 12340058 washer and anchor mount (part of seatbelt assembly 12480530) to bracket on left side body and "B" pillar and secure with 12340259-6 bolt as shown in figure 31. Tighten bolt to 35-40 lb-ft (48-54 N•m).

(2) Position retractor (part of seatbelt assembly 12480530) to bracket assembly (12342372) on left "B" pillar and secure with 2436164 washer and 454970 screw as shown in figure 31. Tighten screw to 35-40 lb-ft (48-54 N•m).

NOTE

Ensure seatbelt strap is positioned over "B" pillar padding assembly during installation.

(3) Loosen two screws and plate on 12342955 "B" pillar padding assembly. Position "B" pillar padding assembly to bracket assembly (12342683) on left "B" pillar as shown in figure 32.

(4) Install 12341856 washer and "D" ring (part of seatbelt assembly 12480530) to "B" pillar padding assembly (12342955) and bracket assembly (12342683) on left "B" pillar and secure with 12340259-7 bolt as shown in figure 32. Tighten bolt to 35-40 lb-ft (48-54 N•m).

(5) Using slots in "B" pillar padding assembly (12342955) slide two screws and plate upward until plate makes contact with bottom of bracket assembly (12342683) as shown in figure 32A.

(6) Secure plate to bottom of bracket assembly (12342683) with two screws as shown in figure 32A. Tighten screws to 30 lb-in. (3 N•m).

(7) Position 12341856 washer and anchor mount (part of seatbelt assembly 12480530) to bracket on right side body and "B" pillar and secure with 12340259-6 bolt as shown in figure 31. Tighten bolt to 35-40 lb-ft (48-54 N•m).

(8) Position retractor (part of seatbelt assembly 12480530) to bracket assembly (12342372) on right "B" pillar and secure with 2436164 washer and 454970 screw as shown in figure 31. Tighten screw to 35-40 lb-ft (48-54 N•m).

NOTE

Ensure seatbelt strap is positioned over "B" pillar padding assembly during installation.

(9) Loosen two screws and plate on 12342954 "B" pillar padding assembly. Position "B" pillar padding assembly to bracket assembly (12342683) on right "B" pillar as shown in figure 32.

(10) Install 12341856 washer and "D" ring (part of seatbelt assembly 12480530) to "B" pillar padding assembly (12342954) and bracket assembly (12342683) on right "B" pillar and secure with 12340259-7 bolt as shown in figure 32. Tighten bolt to 35-40 lb-ft (48-54 N•m).

(11) Using slots in "B" pillar padding assembly (12342954), slide two screws and plate upward until plate makes contact with bottom of bracket assembly (12342683) as shown in figure 32A.

(12) Secure plate to bottom of bracket assembly (12342683) with two screws as shown in figure 32A. Tighten screws to 30 lb-in. (3 N•m).

NOTE

Perform steps (13), (14), and (15) only if two-man soft-top assembly is installed.

(13) Install 12342959 extension assembly to left side of top assembly as shown in figure 33A.

(14) Install 12342959 extension assembly to right side of top assembly as shown in figure 33A.

(15) Secure top assembly and rear curtain of two-man soft-top assembly to turnbuttons on left and right side of "B" pillar as shown in figure 33.

m. FINAL PREPARATION.

NOTE

Steps (1) and (2) below do not apply to vehicles equipped with high back seat.

(1) Install existing two rods, bushings, and MS16562-20 pins to 12338503-1 seat assembly as shown in figure 34.

(2) Install existing seat back and cushion to seat assembly. (Refer to TM 9-2320-280-20.)

(3) Install driver's seat assembly. (Refer to TM 9-2320-280-20.)

(4) Install companion seat back. (Refer to TM 9-2320-280-20.)

(5) Install enclosure panels, if removed. (Refer to TM 9-2320-280-20.)

(6) Install cargo barrier, if removed. (Refer to TM 9-2320-280-20.)

(7) Install fixed doors, if removed. (Refer to TM 9-2320-280-20.)

(8) Install rear seat backs, if removed. (Refer to TM 9-2320-280-20.)

(9) Install rear curtain, if removed. (Refer to TM 9-2320-280-20.)

(10) Install shelter, if removed. (Refer to TM 9-2320-280-20.)

(11) Install troop seats, if removed. (Refer to TM 9-2320-280-20.)

(12) Connect battery ground cable. (Refer to TM 9-2320-280-20.)

(13) Spot paint as necessary. (Refer to TM 43-0139.)

10.2. REAR SEAT, NON-ARMORED VEHICLE.

WARNING

All seatbelt anchor point hardware must be replaced with the new hardware provided in the kit to ensure adequate strength. Failure to do this may result in injury to personnel.

a. VEHICLE PREPARATION.

- (1) Disconnect battery ground cable. (Refer to TM 9-2320-280-20.)
- (2) Remove rear seat backs, if installed. (Refer to TM 9-2320-280-20.)
- (3) Remove rear seatbelt assemblies. (Refer to TM 9-2320-280-20.)
- (4) Remove rear fixed doors, if installed. (Refer to TM 9-2320-280-20.)

b. LEFT WHEELHOUSE REINFORCEMENT INSTALLATION.

- (1) Remove two screws, four washers, and two nuts from left wheelhousing as shown in figure 35.
- (2) Enlarge two holes on left wheelhousing to 0.500-inch diameter as shown in figure 35.
- (3) Position 12342736 template to underside of left wheelhousing and secure with two 441426 screws and 214442 nuts as shown in figure 36.
- (4) Position 12342375 wheelhouse reinforcement to template on underside of left wheelhousing. Using wheelhouse reinforcement as a template, locate, mark, and drill five 0.191-inch diameter holes as shown in figure 36.
- (5) Remove two screws, nuts, and template from left wheelhousing as shown in figure 36. Retain screws and nuts for later use.
- (6) Use a 0.328-inch diameter drill to countersink hole marked "A" on left wheelhousing as shown in figure 37.
- (7) Position wheelhouse reinforcement to underside of left wheelhousing and secure with four NAS9031BNS-6-03 rivets and NAS9303B-6-3 rivet as shown in figures 36 and 37.

c. LEFT WHEELHOUSE RETRACTOR MOUNT INSTALLATION.

- (1) Position 12342727 template to left wheelhousing and secure with existing two screws (441426) and nuts (214442) retained from para. b., step (5) as shown in figure 38.
- (2) Using 12342727 template, locate and drill three 0.125-inch diameter holes in left wheelhousing as shown in figure 38.
- (3) Remove two screws, nuts, and template from left wheelhousing as shown in figure 38. Retain screws and nuts for later use.
- (4) Enlarge holes drilled in step (2) to 0.500-inch diameter as shown in figure 38.
- (5) Install existing screw and two washers, removed in para. b., step (1), and 9422300 nut in hole on left wheelhousing as shown in figure 39.
- (6) Install 12342374 rear retractor mounting bracket to left wheelhousing and secure with two 454974 screws, 453719 screws, eight 2436164 washers, and four 9422300 nuts as shown in figure 39. Tighten nuts to 35-40 lb-ft (48-54 N•m).
- (7) Position 549220 turnbutton to rear retractor mounting bracket on left wheelhousing and secure with two M24243/1-A405 rivets as shown in figure 39.

d. RIGHT WHEELHOUSE REINFORCEMENT INSTALLATION.

- (1) Remove two screws, four washers, and two nuts from right wheelhousing as shown in figure 35.
- (2) Enlarge two holes on right wheelhousing to 0.500-inch diameter as shown in figure 35.
- (3) Position 12342736 template to underside of right wheelhousing and secure with two screws (441426) and nuts (214442) retained from para. c., step (3) as shown in figure 40.
- (4) Position 12342376 wheelhouse reinforcement to template on underside of right wheelhousing. Using wheelhouse reinforcement as a template, locate, mark, and drill six 0.191-inch diameter holes as shown in figure 40.
- (5) Remove two screws, nuts, and template from right wheelhousing as shown in figure 40. Retain screws and nuts for later use.
- (6) Use a 0.328-inch diameter drill to countersink hole marked "A" on right wheelhousing as shown in figure 41.
- (7) Position wheelhouse reinforcement to underside of right wheelhousing and secure with five M7885/2-6-3 rivets and NAS9303B-6-3 rivet as shown in figures 40 and 41.

e. RIGHT WHEELHOUSE RETRACTOR MOUNT INSTALLATION.

- (1) Position 12342728 template to right wheelhousing and secure with existing two screws (441426) and nuts (214442) retained from para. d., step (5) as shown in figure 38.
- (2) Using template, locate and drill three 0.125-inch diameter holes in right wheelhousing as shown in figure 38.
- (3) Remove two screws, nuts, and template from right wheelhousing as shown in figure 38.
- (4) Enlarge holes drilled in step (2) to 0.500-inch diameter as shown in figure 38.
- (5) Install existing screw and two washers removed in para. d., step (1) and 9422300 nut in hole on right wheelhousing as shown in figure 39.
- (6) Install 12342374 rear retractor mounting bracket to right wheelhousing and secure with two 454974 screws, 453719 screws, eight 2436164 washers, and four 9422300 nuts as shown in figure 39. Tighten nuts to 35-40 lb-ft (48-54 N•m).
- (7) Position 549220 turnbutton to rear retractor mounting bracket on right wheelhousing and secure with two M24243/1-A405 rivets as shown in figure 39.

f. LEFT AND RIGHT SEATBELT ASSEMBLY INSTALLATION.

- (1) Position retractor (part of seatbelt assembly 12480530) to rear retractor mounting bracket on left wheelhousing and secure with 453124 screw, two 2436164 washers, and 9422300 nut as shown in figure 42. Tighten nut to 35-40 lb-ft (48-54 N•m).
- (2) Position 12341856 washer, "D" ring (part of seatbelt assembly 12480530, 2436164 washer, and 12340259-5 bolt to left rear retractor mounting bracket. Secure bolt with 2436164 washer and 9422300 nut as shown in figure 42. Tighten nut to 35-40 lb-ft (48-54 N•m).

NOTE

Ensure that release button on the buckle is positioned toward the tunnel.

- (3) Position 12341856 washer and buckle (part of seatbelt assembly 12480530) to left tunnel and secure with 12340259-3 bolt as shown in figure 42. Tighten bolt to 35-40 lb-ft (48-54 N•m).

(4) Install 12340058 washer and anchor mount (part of seatbelt assembly 12480530) to bracket on left side body and secure with 12340259-6 bolt as shown in figure 42. Tighten bolts to 35-40 lb-ft (48-54 N•m).

(5) Position retractor (part of seatbelt assembly 12480530) to rear retractor mounting bracket on right wheelhousing and secure with 453124 screw, two 2436164 washers, and 9422300 nut as shown in figure 42. Tighten nut to 35-40 lb-ft (48-54 N•m).

(6) Position 12340058 washer, "D" ring (part of seatbelt assembly 12480530), 2436164 washer, and 12340259-5 bolt to right rear retractor mounting bracket. Secure bolt with 2436164 washer and 9422300 nut as shown in figure 42. Tighten nut 35-40 lb-ft (48-54 N•m).

NOTE

Ensure that release button on the buckle is positioned towards the tunnel.

(7) Position 12340058 washer and buckle (part of seatbelt assembly 12480530) to right tunnel and secure with 12340259-3 bolt as shown in figure 42. Tighten bolt to 35-40 lb-ft (48-54 N•m).

(8) Install 12340058 washer and anchor mount (part of seatbelt assembly 12480530) to bracket on right side body and secure with 12340259-6 bolt as shown in figure 42. Tighten bolt to 35-40 lb-ft (48-54 N•m).

g. FINAL PREPARATION.

- (1) Install rear seat backs, if removed. (Refer to TM 9-2320-280-20.)
- (2) Install rear fixed doors, if removed. (Refer to TM 9-2320-280-20.)
- (3) Connect battery ground cable. (Refer to TM 9-2320-280-20.)
- (4) Spot paint as necessary. (Refer to TM 43-0139.)

10.3. FRONT AND REAR SEATS, BASIC ARMORED VEHICLE.

WARNING

All seatbelt anchor point hardware must be replaced with the new hardware provided in the kit to ensure adequate strength. Failure to do this may result in injury to personnel.

NOTE

Body side panels beneath the "B" pillar must be free of dents and/or body filler material to ensure structural rigidity when reinforcements are installed. Body side panels damaged or previously repaired must be replaced prior to installation of kit.

a. VEHICLE PREPARATION.

- (1) Disconnect battery ground cable. (Refer to TM 9-2320-280-20.)
- (2) Remove driver's seat and seat back cushions. (Refer to TM 9-2320-280-20.)
- (3) Remove driver's seat frame. (Refer to TM 9-2320-280-20.)
- (4) Remove companion seat back. (Refer to TM 9-2320-280-20.)
- (5) Remove front and rear seatbelt assemblies. (Refer to TM 9-2320-280-20.)
- (6) Remove rear seat backs. (Refer to TM 9-2320-280-20.)
- (7) Remove rear doors. (Refer to TM 9-2320-280-20.)

- (8) Remove cable stowage cleat, if installed. (Refer to TM 9-2320-280-20.)
- (9) Remove missile guidance set (MGS) battery rack assembly, if installed. (Refer to TM 9-2320-280-20.)

b. LEFT RABBET REINFORCEMENT INSTALLATION.

NOTE

It may be necessary to replace identification data plate, if damaged during removal.

- (1) Mark an outline around identification data plate and driver's seat adjustment decal on left rabbet assembly as shown in figure 1.
- (2) Remove identification data plate and driver's seat decal from left rabbet assembly as shown in figure 1.
- (3) Remove four screws, washers, and bracket from left side body and "B" pillar as shown in figure 2.

NOTE

- Clamping devices are necessary during installation of reinforcement to left rabbet assembly.
- Ensure inside surface of rabbet assembly is free of foreign materials.
- Ensure edges of reinforcement are flush with "B" pillar and left side body prior to hole drilling.
- Upon completion of drilling, remove any sharp edges and burrs.

- (4) Position 12342379 reinforcement to inside of left rabbet assembly and position 12342729 template to outside of left rabbet assembly. Using template, drill eleven 0.191-inch diameter holes through left rabbet assembly and reinforcement as shown in figure 3.
- (5) Use 0.328-inch diameter drill bit to countersink holes on left rabbet assembly within marked outline from data plate and driver's seat adjustment decal as shown in figure 3.
- (6) Apply 00206 part 1 activator to inside of left rabbet assembly as shown in figure 4.
- (7) Apply 00206 part 2 adhesive to mating surface of reinforcement as shown in figure 5.

CAUTION

When installing reinforcement to rabbet assembly, use clamping devices to compress adhesive between surfaces and to eliminate any air pockets and gaps. Failure to do this may result in insufficient bonding.

NOTE

Use NAS9301BNS-6-03 rivets in drilled holes which did not require countersinking and NAS9303B-6-3 rivets in countersunk holes drilled in left rabbet assembly.

- (8) Install reinforcement to left rabbet assembly and secure with eleven (any combination) NAS9301BNS-6-03 or NAS9303B-6-3 rivets as shown in figures 5 and 6.
- (9) Using existing holes for identification data plate on left rabbet assembly as a template, drill four 0.128-inch diameter holes through reinforcement as shown in figure 6.
- (10) Install identification data plate to left rabbet assembly and secure with four M24243/1-A404 rivets as shown in figure 6.

(11) Remove backing material on 12339101 driver's seat adjustment decal and install to left rabbet assembly as shown in figure 6.

(12) Install existing bracket, four 186676 screws and MS27183-10 washers to left side body and "B" pillar as shown in figure 7.

c. LEFT BODY REINFORCEMENT INSTALLATION.

(1) Using 12342731 reinforcement, mark a centerline on exterior side of reinforcement and apply two layers of PPP-T-60 tape to interior side of reinforcement as shown in figure 8.

(2) Remove screw, two washers, and nut from left side body and "B" pillar as shown in figure 43.

(3) Locate and mark a centerline on left side body and "B" pillar as shown in figure 43.

(4) Aline centerline on reinforcement to centerline on left side body and "B" pillar. Apply pressure to reinforcement to transfer rivet head locations onto tape as shown in figure 43.

(5) Using tape as a template, transfer rivet head locations by center punching tape on reinforcement and remove tape as shown in figure 43.

NOTE

Upon completion of drilling, remove any sharp edges and burrs.

(6) Using marked locations on reinforcement, drill 0.406-inch diameter clearance hole for rivet heads as shown in figure 43.

(7) Locate, mark, and drill seven 0.125-inch diameter holes in reinforcement as shown in figure 10.

(8) Aline centerline on reinforcement to centerline on left side body and "B" pillar. Using left side body and "B" pillar as a template, locate and mark screw hole as shown in figure 44.

(9) Aline centerline on reinforcement to centerline on left side body and "B" pillar. Using reinforcement as a template, drill seven 0.191-inch diameter holes through reinforcement and in left side body as shown in figure 45.

(10) Drill 0.281-inch diameter hole in reinforcement marked in step (8) as shown in figure 44.

(11) Apply 00206 part 1 activator to left side body and "B" pillar as shown in figure 12.

(12) Apply 00206 part 2 adhesive to mating surface of reinforcement as shown in figure 13.

(13) Install reinforcement to left side body and "B" pillar and secure with seven NAS9301BNS-6-03 rivets as shown in figure 45.

(14) Position existing screw and two washers removed in step (2) in reinforcement and left side body. Secure screw with M45913/4-4CG82 nut as shown in figure 45.

(15) Drill three 0.191-inch diameter holes through reinforcement and left side body as shown in figure 45.

(16) Using holes in bottom of reinforcement, install three NAS9301BNS-6-03 rivets through reinforcement and left side body as shown in figure 45.

d. RIGHT RABBET REINFORCEMENT INSTALLATION.

NOTE

It may be necessary to replace weight dimensional data plate, if damaged during removal.

(1) Mark an outline around weight and dimensional data plate on right rabbet assembly as shown in figure 14.

- (2) Remove weight and dimensional data plate on right rabbet assembly as shown in figure 14.
- (3) Remove four screws, washers, and bracket from right side body and "B" pillar as shown in figure 2.

NOTE

- Clamping devices are necessary during installation of reinforcement to right rabbet assembly.
- Ensure inside surface of rabbet assembly is free of foreign materials.
- Ensure edges of reinforcement are flush with "B" pillar and right side body prior to hole drilling.
- Upon completion of drilling, remove any sharp edges and burrs.

(4) Position 12342380 reinforcement to inside of right rabbet assembly and position 12342730 template to outside of right rabbet assembly. Using template, drill eleven 0.191-inch diameter holes through right rabbet assembly and reinforcement as shown in figure 15.

(5) Use 0.328-inch diameter drill bit to countersink marked holes on right rabbet assembly within outline from weight and dimensional data plate as shown in figure 15.

(6) Apply 00206 part 1 activator to inside of right rabbet assembly as shown in figure 16.

(7) Apply 00206 part 2 adhesive to mating surface of reinforcement as shown in figure 17.

CAUTION

When installing reinforcement to rabbet assembly, use clamping devices to compress adhesive between surfaces and to eliminate any air pockets and gaps. Failure to do this may result in insufficient bonding.

NOTE

Use M7885/2-6-3 rivets in drilled holes which did not require countersinking and NAS9303B-6-3 rivets in countersunk holes drilled in right rabbet assembly.

(8) Install reinforcement to right rabbet assembly and secure with eleven (any combination) NAS9301BNS-6-03 or NAS9303B-6-3 rivets as shown in figure 18.

(9) Using existing holes for weight and dimensional data plate on right rabbet assembly, drill four 0.128-inch diameter holes through right rabbet assembly and reinforcement as shown in figure 18.

(10) Install weight and dimensional data plate to right rabbet assembly and secure with four M24243/1-A404 rivets as shown in figure 18.

(11) Install existing bracket, four 186676 screws, and MS27183-10 washers to right side of body and "B" pillar as shown in figure 7.

e. RIGHT BODY REINFORCEMENT INSTALLATION.

(1) Using 12342731 reinforcement, mark a centerline on exterior side of reinforcement and apply two layers of PPP-T-60 tape to interior side of reinforcement as shown in figure 8.

(2) Remove screw, two washers, and nut from right side body and "B" pillar as shown in figure 43.

(3) Locate and mark a centerline on right side body and "B" pillar as shown in figure 43.

(4) Aline centerline on reinforcement to centerline on right side body and "B" pillar. Apply pressure to reinforcement to transfer rivet head locations onto tape as shown in figure 43.

(5) Using tape as a template, transfer rivet head locations by center punching tape on reinforcement and remove tape as shown in figure 43.

NOTE

Upon completion of all drilling, remove any sharp edges and burrs.

(6) Using marked locations on reinforcement, drill 0.406-inch diameter clearance hole for rivet heads as shown in figure 43.

(7) Locate, mark, and drill seven 0.125-inch diameter holes in reinforcement as shown in figure 10.

(8) Aline centerline on reinforcement to centerline on right side body and "B" pillar. Using right side body and "B" pillar as a template, locate and mark screw hole as shown in figure 44.

(9) Aline centerline on reinforcement to centerline on right side body and "B" pillar. Using reinforcement as a template, drill seven 0.191-inch diameter holes through reinforcement and in right side body as shown in figure 45.

(10) Drill 0.281-inch diameter hole in reinforcement marked in step (8) as shown in figure 44.

(11) Apply 00206 part 1 activator to right side body and "B" pillar as shown in figure 12.

(12) Apply 00206 part 2 adhesive to mating surface of reinforcement as shown in figure 13.

(13) Install reinforcement to right side body and "B" pillar and secure with seven NAS9301BNS-6-03 rivets as shown in figure 45.

(14) Position existing screw and two washers removed in step (2) in reinforcement and right side body. Secure screw with M45913/4-4CG8Z nut as shown in figure 45.

(15) Drill three 0.191-inch diameter holes through reinforcement and right side body as shown in figure 45.

(16) Using holes in bottom of reinforcement, install three NAS9301BNS-6-03 rivets through reinforcement and left side body as shown in figure 45.

f. LEFT TUNNEL REINFORCEMENT ASSEMBLY INSTALLATION.

(1) Remove screw, retainer, and insulation from left side tunnel as shown in figure 19.

(2) Remove rivet on left tunnel as shown in figure 19.

(3) Position 12342723 template to left side tunnel and drill three 0.125-inch diameter holes as shown in figure 20.

(4) Enlarge hole drilled in step (3) to 0.468-inch diameter in left side tunnel as shown in figure 21.

NOTE

Ensure that release button on the buckle is positioned towards tunnel.

(5) Position 12342386 reinforcement assembly to left side tunnel and secure with 12341856 washer, buckle (part of seatbelt assembly 12342377-1), and 12340259-3 bolt as shown in figure 21. Tighten bolt to 35-40 lb-ft (48-54 N•m).

(6) Enlarge two holes drilled in step (3) to 0.191-inch diameter through left side tunnel and reinforcement assembly as shown in figure 21.

(7) Install two NAS9301BNS-6-03 rivets through holes in left side tunnel and reinforcement assembly as shown in figure 21.

- (8) Install existing insulation, retainer, and screw to left side tunnel as shown in figure 19.

g. RIGHT TUNNEL REINFORCEMENT ASSEMBLY INSTALLATION.

- (1) Remove two screws, clamp, retainer, and insulation from right side tunnel as shown in figure 22.
- (2) Remove two rivets on right side tunnel as shown in figure 22.
- (3) Position 12342724 template to right side tunnel and drill three 0.125-inch diameter holes as shown in figure 23.
- (4) Enlarge hole drilled in step (3) to 0.468-inch diameter as shown in figure 24.

NOTE

Ensure that release button on the buckle is positioned towards tunnel.

- (5) Position 12342385 reinforcement assembly to right side tunnel and secure with 12340058 washer, buckle (part of seatbelt assembly 12480530, and 12340259-3 bolt as shown in figure 24. Tighten bolt to 35-40 lb-ft (48-54 N•m).

- (6) Enlarge two holes drilled in step (3) to 0.191-inch diameter through right side tunnel and drill through reinforcement assembly as shown in figure 24.

- (7) Install two NAS9301BNS-6-03 rivets through holes in right side tunnel and reinforcement assembly as shown in figure 24.

- (8) Install existing insulation, retainer clamp, and two screws to right side tunnel as shown in figure 22.

h. LEFT AND RIGHT UPPER "B" PILLAR PREPARATION.

- (1) Remove edge trim from front and rear sections of left "B" pillar cover as shown in figure 46.
- (2) Locate, mark, and drill 0.313-inch diameter hole in left "B" pillar cover as shown in figure 46.
- (3) Remove four screws, washers, and left "B" pillar cover as shown in figure 47.
- (4) Install 12342737 template to outside of left "B" pillar and secure with two existing screws and washers removed in step (3) as shown in figure 48.
- (5) Using template and GGG-D-751D drill bit, locate and drill 0.125-inch diameter hole in left "B" pillar as shown in figure 48.
- (6) Remove two screws, washers, and template from left "B" pillar and enlarge hole drilled in step (5) to 0.468-inch diameter as shown in figure 48.
- (7) Remove trim from front and rear sections of right "B" pillar cover as shown in figure 46.
- (8) Locate, mark, and drill 0.313-inch diameter hole in right "B" pillar cover as shown in figure 46.

NOTE

- For M966 and M1036 vehicles without upper gun mount installed on right "B" pillar cover, proceed directly to step 10.
- For M1025 and M1026 vehicles with upper gun mount installed on right "B" pillar cover, complete steps 9 and 10.

- (9) Remove four screws, eight washers, four nut, and upper gun mount bracket as shown in figure 49.

- (10) Remove four screws, washers, and right "B" pillar cover as shown in figure 47.

(11) Install 12342738 template to outside of right "B" pillar and secure with two existing screws and washers removed in step (10) as shown in figure 48.

(12) Using template and GGG-D-751D drill bit, locate and drill 0.125-inch diameter hole in right "B" pillar as shown in figure 48.

(13) Remove two screws, washers, and template on right "B" pillar and enlarge hole drilled in step (12) to 0.468-inch diameter as shown in figure 48.

i. LEFT LOWER BRACKET ASSEMBLY INSTALLATION.

(1) Position 12342732 template on "B" pillar and "B" beam. Using template, drill two 0.125-inch diameter holes in "B" pillar as shown in figure 50.

(2) Enlarge two holes drilled in step (1) to 0.343-inch diameter as shown in figure 51.

(3) Position 12342733 template on "B" pillar and "B" beam. Using template, drill two 0.125-inch diameter holes in "B" pillar as shown in figure 50.

(4) Enlarge two holes drilled in step (3) to 0.343-inch diameter as shown in figure 51.

(5) Install 12342372 bracket assembly to "B" pillar and secure with four 454869 screws and 2436162 washers as shown in figure 51.

j. RIGHT LOWER BRACKET ASSEMBLY INSTALLATION.

(1) Remove four rivets and VPC bracket from left side "B" pillar as shown in figure 52.

(2) Position 12342732 template on "B" pillar and "B" beam. Using template, drill two 0.125-inch diameter holes in "B" pillar as shown in figure 50.

(3) Enlarge two holes drilled in step (2) to 0.343-inch diameter as shown in figure 51.

(4) Position 12342733 template on "B" pillar and "B" beam. Using template, drill two 0.125-inch diameter holes in "B" pillar as shown in figure 50.

(5) Enlarge two holes drilled in step (4) to 0.343-inch diameter as shown in figure 51.

(6) Install 12342372 bracket assembly to "B" pillar and secure with four 454869 screws and 2436162 washers as shown in figure 51.

(7) Remove five screws, nuts, receptacle, and clamp from VPC bracket as shown in figure 52.

(8) Position receptacle in 12340654-1 bracket and secure with four MS35206-246 screws and 271163 nuts as shown in figure 53.

(9) Position existing cap eyelet to mount hole on bracket and secure with MS35206-246 screw and 271163 nut as shown in figure 53.

(10) Locate, mark, and drill two 0.191-inch diameter holes in "B" pillar as shown in figure 53.

(11) Install bracket to "B" pillar and secure with four 12339355-1 rivets as shown in figure 53.

(12) Locate, mark, and drill a 0.172-inch diameter hole on "B" pillar front reinforcement as shown in figure 54.

(13) Position MS21333-75 clamp on VPC cable and secure clamp to hole drilled in step (12) using 12342499-1 screw as shown in figure 54.

(14) Locate, mark, and drill two 0.281-inch diameter holes on "B" beam as shown in figure 54.

(15) Locate, mark, and drill two 0.191-inch diameter holes on "B" pillar as shown in figure 54.

(16) Position existing cable stowage cleat to holes drilled in step (14) and secure with two existing screws, washers, and M45913/4-4CG8Z nuts as shown in figure 54.

(17) Position two MS21333-75 clamps on VPC cable and secure clamps to holes drilled in step (15) using two MS51958-63 screws and 271169 nuts as shown in figure 54.

k. FRONT SEATBELT ASSEMBLY INSTALLATION.

(1) Position 12340058 washer and anchor mount (part of seatbelt assembly 12480530) to bracket on left side body and "B" pillar and secure with 12340259-6 bolt as shown in figure 55. Tighten bolt to 35-40 lb-ft (48-54 N•m).

(2) Install retractor (part of seatbelt assembly 12480530) to bracket assembly (12342372) on left "B" pillar and secure with 2436164 washer and 454970 screw as shown in figure 55. Tighten screw to 35-40 lb-ft (48-54 N•m).

(3) Position 12342381 bracket, 12341856 washer, and "D" ring (part of seatbelt assembly 12480530) to left "B" pillar. Secure with 12340259-4 bolt and 12342722 reinforcement as shown in figure 55. Tighten bolt to 35-40 lb-ft (48-54 N•m).

(4) Position 12340058 washer and anchor mount (part of seatbelt assembly 12480530) to bracket on right side of body and "B" pillar and secure with 12340259-6 bolt as shown in figure 55. Tighten bolt to 35-40 lb-ft (48-54 N•m).

(5) Install retractor (part of seatbelt assembly 12480530) to bracket assembly (12342372) on right "B" pillar and secure with 2436164 washer and 454970 screw as shown in figure 55. Tighten screw to 35-40 lb-ft (48-54 N•m).

(6) Position 12342381 bracket, 12341856 washer, and "D" ring (part of seatbelt assembly 12480530) to right "B" pillar. Secure with 12340259-4 bolt and 12342722 reinforcement as shown in figure 55. Tighten bolt to 35-40 lb-ft (48-55 N•m).

l. "B" PILLAR COVER PADDING ASSEMBLY INSTALLATION.

(1) Position existing left "B" pillar cover to mount holes on "B" pillar and roof. Secure bottom section of "B" pillar cover to "B" pillar with two MS27183-11 washers and MS35206-298 screws as shown in figure 56.

(2) Install MS27183-11 washer and MS35206-298 screw in mount holes on top rear section of roof and left "B" pillar cover as shown in figure 56.

(3) Position 12446739 padding assembly to top section of left "B" pillar cover and aline mount holes as shown in figure 57.

(4) Position three 2436161 washers, and B1821BH025C075N bolts in mount holes on padding assembly and left "B" pillar cover. Install three 2436161 washers and 9419454 nuts as shown in figure 57. Do not tighten bolts and nuts.

(5) Install MS27183-11 washer and MS35206-298 screw in mount holes on padding assembly and left front section of roof as shown in figure 57. Tighten screw to 120 lb-in. (13 N•m).

(6) Tighten bolts and nuts installed in step (4) to 120 lb-in. (13 N•m).

(7) Install 12340103-4 and 12340103-3 edge trim pieces on front and rear sections of left "B" pillar cover as shown in figure 57.

NOTE

- For M1025 and M1026 vehicles with upper rifle mount installed on right padding assembly, accomplish steps (15) through (23) only.
- For M966 and M1036 vehicles without upper rifle mount installed on right padding assembly, complete steps (8) through (14) only.

(8) Position existing right "B" pillar cover to mount holes on "B" pillar and roof. Secure bottom section of "B" pillar cover to "B" pillar with two MS27183-11 washers and MS35206-298 screws as shown in figure 56.

(9) Install MS27183-11 washer and MS35206-298 screw in mount holes on top rear section of roof and right "B" pillar cover as shown in figure 56.

(10) Position 12446741 padding assembly to top section of right "B" pillar cover and align mount holes as shown in figure 58.

(11) Install three 2436161 washers and B1821BH025C075N bolts in mount holes on padding assembly and right "B" pillar cover and install 2436161 washers and 9419454 nuts as shown in figure 58. Do not tighten bolts and nuts.

(12) Install MS27183-11 washer and MS35206-298 screw in mount holes on padding assembly and front section of roof as shown in figure 58. Tighten screw to 120 lb-in. (13 N•m).

(13) Tighten bolts and nuts installed in step (11) to 120 lb-in. (13 N•m).

(14) Install 12340103-4 and 12340103-3 edge trim pieces on front and rear sections of right "B" pillar cover as shown in figure 58.

NOTE

Steps (15) through (23) apply to M1025 and M1026 vehicles with upper rifle mount installed on right padding assembly only.

(15) Position existing right "B" pillar cover to mount holes on "B" pillar and roof. Secure bottom section of "B" pillar cover to "B" pillar with two MS27183-11 washers and MS35206-298 screws as shown in figure 56.

(16) Install MS27183-11 washer and MS35206-298 screw in mount holes on top rear section of roof and right "B" pillar cover as shown in figure 56.

(17) Position 12446741 padding assembly to top section of right "B" pillar cover and align mount holes as shown in figure 60.

(18) Install MS27183-11 washer and MS35206-298 screw in mount holes on padding assembly and right front section of roof as shown in figure 60. Do not tighten screw.

(19) Position 2436161 washer and B1821BH025C075N bolt in mount holes on padding assembly and right "B" pillar cover and install 2436161 washer and 9419454 nut as shown in figure 60. Do not tighten bolt and nut.

(20) Position 12340487 clamp to mount holes on 12446762 mount and secure with two MS35206-246 screws, four 9423534 washers, and two NAS1022-N08 nuts as shown in figure 59.

(21) Position mount to mount holes in padding assembly (12446741) and right "B" pillar cover. Secure with two B1821BH025C200N bolts, four 2436161 washers, and two 9419454 nuts as shown in figure 60. Tighten bolts and nuts to 120 lb-in. (13 N•m).

(22) Tighten screw, bolt, and nut installed in steps (19) and (20) to 120 lb-in. (13 N•m).

(23) Install 12340103-4 and 12340103-3 edge trim pieces on front and rear sections of right "B" pillar cover as shown in figure 60.

m. LEFT "C" PILLAR REINFORCEMENT INSTALLATION.

(1) Using 12342725 rear retractor mounting bracket as a template, locate, mark, and drill two 0.468-inch diameter holes in left "C" pillar bracket as shown in figure 61.

(2) Install rear retractor mounting bracket to left "C" pillar bracket and secure with two 453124 screws, 2436164 washers, and 9422300 nuts as shown in figure 61.

(3) Remove two plugs from left rear door jamb as shown in figure 61.

NOTE

- Ensure bottom edge of template is flush to left rear door jamb prior to drilling hole.
- Clamping devices are necessary when drilling left rear door jamb and "C" pillar.

(4) Position 12342739 template to left rear door jamb. Using template, locate and drill 0.125-inch diameter hole in left rear door jamb as shown in figure 62.

NOTE

If 0.125-inch diameter hole drilled in step (4) passes through existing hole in door jamb, remove template and cover hole with tape. Repeat step (4) and scribe a 1.00-inch diameter circle around the hole to act as a guide before performing step (5).

(5) Enlarge hole drilled in step (4) to 1.00-inch diameter as shown in figure 63.

(6) Position upper end of template in hole drilled in step (5) and align bottom edge of template flush to bottom left rear door jamb as shown in figure 63.

(7) Using template and GGG-D-751D drill bit, locate and drill 0.125-inch diameter hole through "C" pillar and left rear retractor mounting bracket as shown in figure 63.

(8) Enlarge hole drilled in step (7) to 0.468-inch diameter as shown in figure 64.

(9) Install 454982 screw, two 2436164 washers, and 9422300 nut in left "C" pillar and rear retractor mounting bracket as shown in figure 64. Tighten screw to 35-40 lb-ft (48-54 N•m).

(10) Install 12339361-2 plug and two 12339361-1 plugs in left door jamb as shown in figure 64.

n. RIGHT "C" PILLAR REINFORCEMENT INSTALLATION.

(1) Using 12342726 rear retractor mounting bracket as a template, locate, mark, and drill two 0.468-inch diameter holes in right "C" pillar bracket as shown in figure 61.

(2) Install rear retractor mounting bracket to right "C" pillar bracket and secure with two 453124 screws, 2436164 washers, and 9422300 nuts as shown in figure 61.

(3) Remove two plugs from right rear door jamb as shown in figure 61.

NOTE

- Ensure bottom edge of template is flush to right rear door jamb prior to drilling hole.
- Clamping devices are necessary when drilling right rear door jamb and "C" pillar.

(4) Position 12342740 template to right rear door jamb. Using template, locate and drill 0.125-inch diameter hole in right rear door jamb as shown in figure 62.

NOTE

If 0.125-inch diameter hole drilled in step (4) passes through existing hole in door jamb, remove template and cover hole with tape. Repeat step (4) and scribe a 1.00-inch diameter circle around the hole to act as a guide before performing step (5).

(5) Enlarge hole drilled in step (3) to 1.00-inch diameter as shown in figure 63.

(6) Position upper end of template in hole drilled in step (5) and align bottom edge of template flush to bottom right rear door jamb as shown in figure 63.

(7) Using template and GGG-D-751D drill bit, locate and drill 0.125-inch diameter hole through "C" pillar and right rear retractor mounting bracket as shown in figure 63.

(8) Enlarge hole drilled in step (7) to 0.468-inch diameter as shown in figure 64.

(9) Install 454982 screw, two 2436164 washers, and 9422300 nut in right "C" pillar and rear retractor mounting bracket as shown in figure 64. Tighten screw to 35-40 lb-ft (48-54 N•m).

(10) Install 12339361-2 plug and two 12339361-1 plugs in right door jamb as shown in figure 64.

o. LEFT AND RIGHT REAR SEATBELT ASSEMBLY INSTALLATION.

(1) Position 12340058 washer, and anchor mount, part of 12480530 seatbelt assembly, to bracket on left side body and secure with 12340259-6 bolt as shown in figure 65. Tighten bolt to 35-40 lb-ft (48-54 N•m).

(2) Position retractor (part of seatbelt assembly 12480530) to rear retractor mounting bracket on left "C" pillar and secure with 2436164 washer and 454970 screw as shown in figure 65. Tighten screw to 35-40 lb-ft (48-54 N•m).

(3) Install 12341856 washer, "D" ring (part of seatbelt assembly 12480530), and 12340259-7 bolt to rear retractor mounting bracket on left "C" pillar as shown in figure 65. Tighten bolt to 35-40 lb-ft (48-54 N•m).

NOTE

Ensure that release button on buckle is positioned towards the tunnel.

(4) Position 12340058 washer and buckle (part of seatbelt assembly 12480530) to left side tunnel and secure with 12340259-3 bolt as shown in figure 66. Tighten bolt to 35-40 lb-ft (48-54 N•m).

(5) Position 12340058 washer, and anchor mount, part of 12480530 seatbelt assembly, to bracket on right side body and secure with 12340259-6 bolt as shown in figure 65. Tighten bolt to 35-40 lb-ft (48-54 N•m).

(6) Position retractor (part of seatbelt assembly 12342377-2) to rear retractor mounting bracket on right "C" pillar and secure with 2436164 washer and 454970 screw as shown in figure 65. Tighten screw to 35-40 lb-ft (48-54 N•m).

(7) Install 12341856 washer, "D" ring (part of seatbelt assembly 12480530), and 12340259-7 bolt to rear retractor mounting bracket on right "C" pillar as shown in figure 65. Tighten bolt to 35-40 lb-ft (48-54 N•m).

NOTE

Ensure that release button on buckle is positioned towards the tunnel.

(8) Position 12340058 washer and buckle (part of seatbelt assembly 12480530) to right side tunnel and secure with 12340259-3 bolt as shown in figure 66. Tighten bolt to 35-40 lb-ft (48-54 N•m).

p. **FINAL PREPARATION.**

NOTE

Steps (1) and (2) below do not apply to vehicles equipped with high back seats.

(1) Install existing two rods, bushing, and MS16562-20 pins to 12338503-1 seat assembly as shown in figure 34.

(2) Install existing seat back and cushion to seat assembly. (Refer to TM 9-2320-280-20.)

(3) Install driver's seat assembly. (Refer to TM 9-2320-280-20.)

(4) Install companion seat back. (Refer to TM 9-2320-280-20.)

(5) Install rear seat backs. (Refer to TM 9-2320-280-20.)

(6) Install rear doors. (Refer to TM 9-2320-280-20.)

(7) Connect battery ground cable. (Refer to TM 9-2320-280-20.)

(8) Remove front and rear seatbelt retractor instruction plates. (Refer to TM 9-2320-280-20 for location of plates.)

(9) Spot paint as necessary. (Refer to TM 43-0139.)

(10) Install missile guidance set (MGS) battery rack assembly. (Refer to TM 9-2320-280-20.)

11. CALIBRATION REQUIREMENTS.

Not applicable.

12. WEIGHT AND BALANCE DATA.

Weight and balance are not significantly affected by this MWO.

13. QUALITY ASSURANCE REQUIREMENTS.

a. General. The following information is furnished to ensure the proper application of the MWO and provide clarification in regard to the adequacy of Installer's Inspection Methods and Procedures applicable to Quality Assurance (QA). Inspection shall be IAW TM 750-245-4.

b. Installer Responsibilities. The installer is responsible for the following instructions in MWO 9-2320-280-35-2, TM 9-2320-280-10, and TM 9-2320-280-20. The installer is responsible for rejecting any vehicle that has damaged, inoperative, or missing vehicle components cited in Preventive Maintenance Checks and Services (PMCS) found in TM 9-2320-280-10. The installer will report 3-Point Seatbelt Retrofit Kits received that are damaged or have any missing component parts so the kit supplier can be properly notified of discrepancies. The installer is responsible for the functional testing of seatbelts after the 3-Point Seatbelt Retrofit Kit is installed. Any deficiencies noted will be corrected before the vehicle leaves the installer's work area. Requirements contained in this MWO shall be included in the installer's inspection plan or Quality Assurance Program. These requirements shall not be construed as eliminating the installer's responsibility from complete compliance with provisions of the contract and submitting products to the Government that meet all requirements of the contract.

c. Government Verification. All QA operations and installation checks and inspections performed by the installer are subject to Government verification at unannounced and varying intervals. Verification will consist of observations and inspections to confirm that practices, methods, and procedures of the installer's written inspection plan are being properly applied; and that Government product inspection to confirm the quality of product offered for Government acceptance does not deviate from prescribed acceptance standards specified to in TM 9-2320-280-10, TM 9-2320-280-20, and TM 750-245-4. Any deviations will be brought to the attention of the installer for correction.

d. In-Process Inspection. During normal assembly operations, applicable modification paragraphs will be used to check the installer's work. After installation is complete, the vehicle will be checked IAW the PMCS check list for correct functioning of the 3-Point Seatbelt Retrofit Kit components and to ensure there are no defective seatbelts. Any defects noted will be corrected by the installer before the vehicle is placed in service. All vehicles modified during a production shift will be checked to ensure product quality.

e. Workmanship Inspection. Inspect all components installed or replaced during the installation of the MWO for smoothness of operation and security of mounting. Correct any faults found.

14. RECORDING AND REPORTING OF THE MODIFICATION.

a. Records and reports. (Refer to DA PAM 738-750.)

b. Marking Equipment.

(1) After 3-Point Seatbelt Retrofit Kit Modification is installed, mark MWO number "9-2320-280-35-2" in the MWO Applied Block and date applied in Date Block on MWO Instruction Plate 10930014.

NOTE

Do not remove previously installed MWO instruction plate(s) that are permanently affixed to reinforcement panel prior to this MWO installation.

(2) Install 10930014 MWO instruction plate by drilling a 0.104-inch diameter hole within designated area on side body reinforcement panel and secure with MS21318-20 drive screw as shown in figure 67.

(3) After drive screw is installed, flatten or remove protruding excess drive screw material from inside of side body reinforcement panel.

c. Identification Data.

Not applicable.

15. MATERIAL CHANGE (MC) NUMBER.

This MWO is authorized by MC number 1-92-06-4401.

16. MODIFICATION IDENTIFICATION.

a. When installed correctly, the 3-Point Seatbelt Retrofit Kit Modification will appear as shown in figures 68, 69, 70, and 71 (Front Seat, Non-Armor), figure 72 (Rear Seat, Non-Armor), and figures 73, 74, 75, and 76 (Front and Rear Seats, Basic Armor).

a. After the 3-Point Seatbelt Retrofit Kit Modification is completed, the High-Mobility Multipurpose Wheeled Vehicle should be checked for secure mounting and smooth operation. Any faults detected or discrepancies noted will be corrected before the vehicle is returned to normal service.

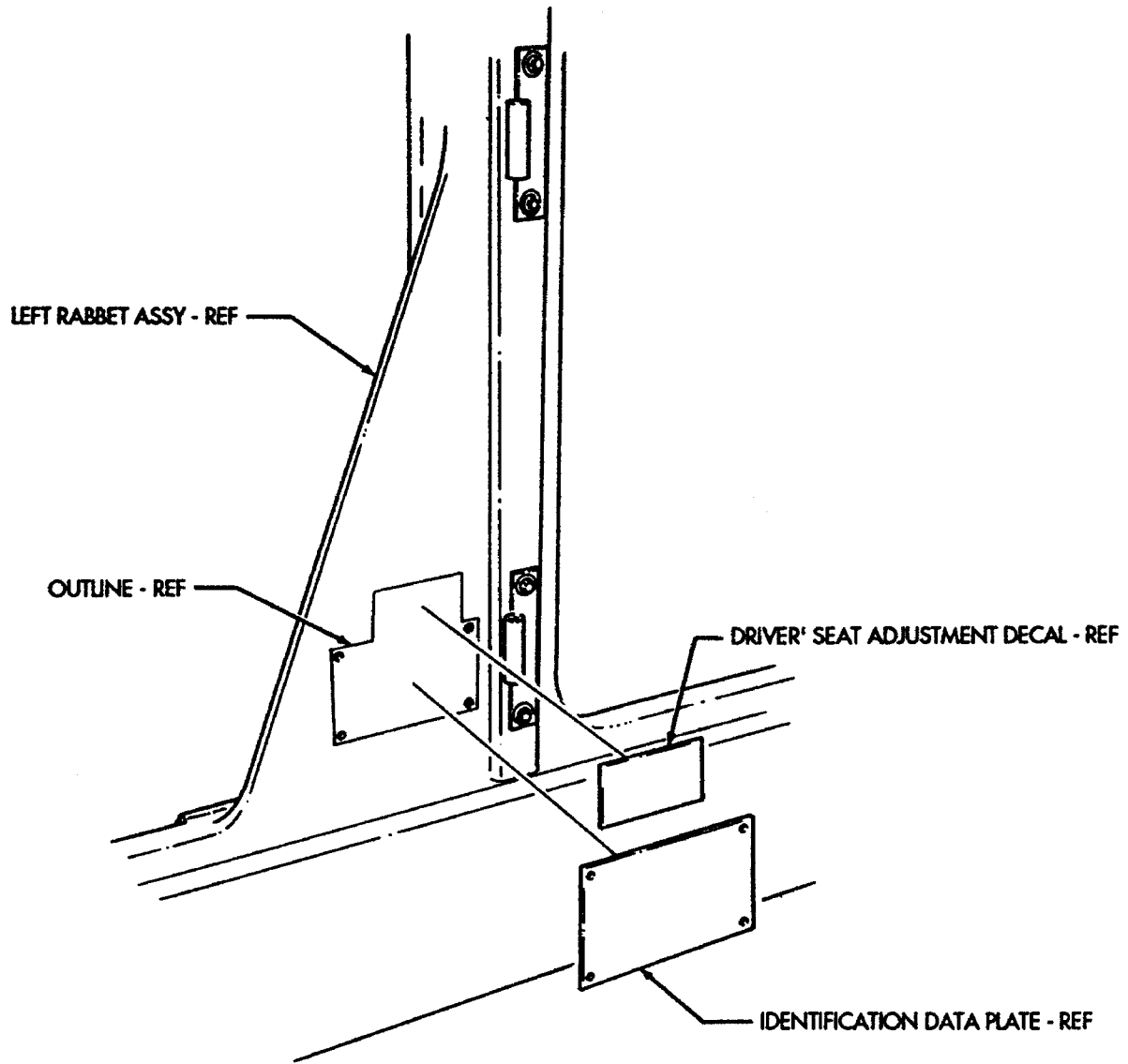
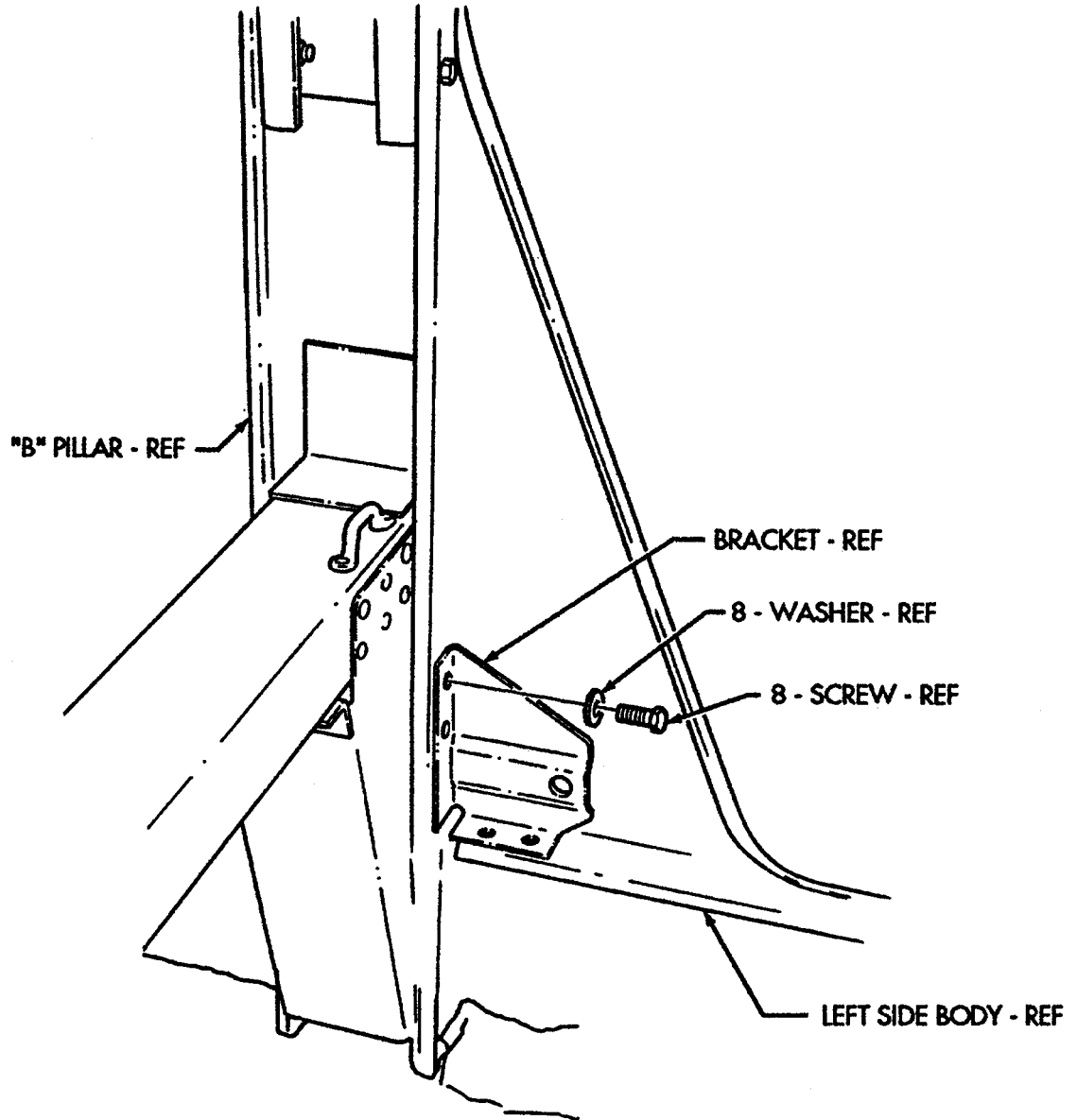

FIGURE 1



(LEFT SIDE SHOWN, RIGHT SIDE OPPOSITE)

FIGURE 2

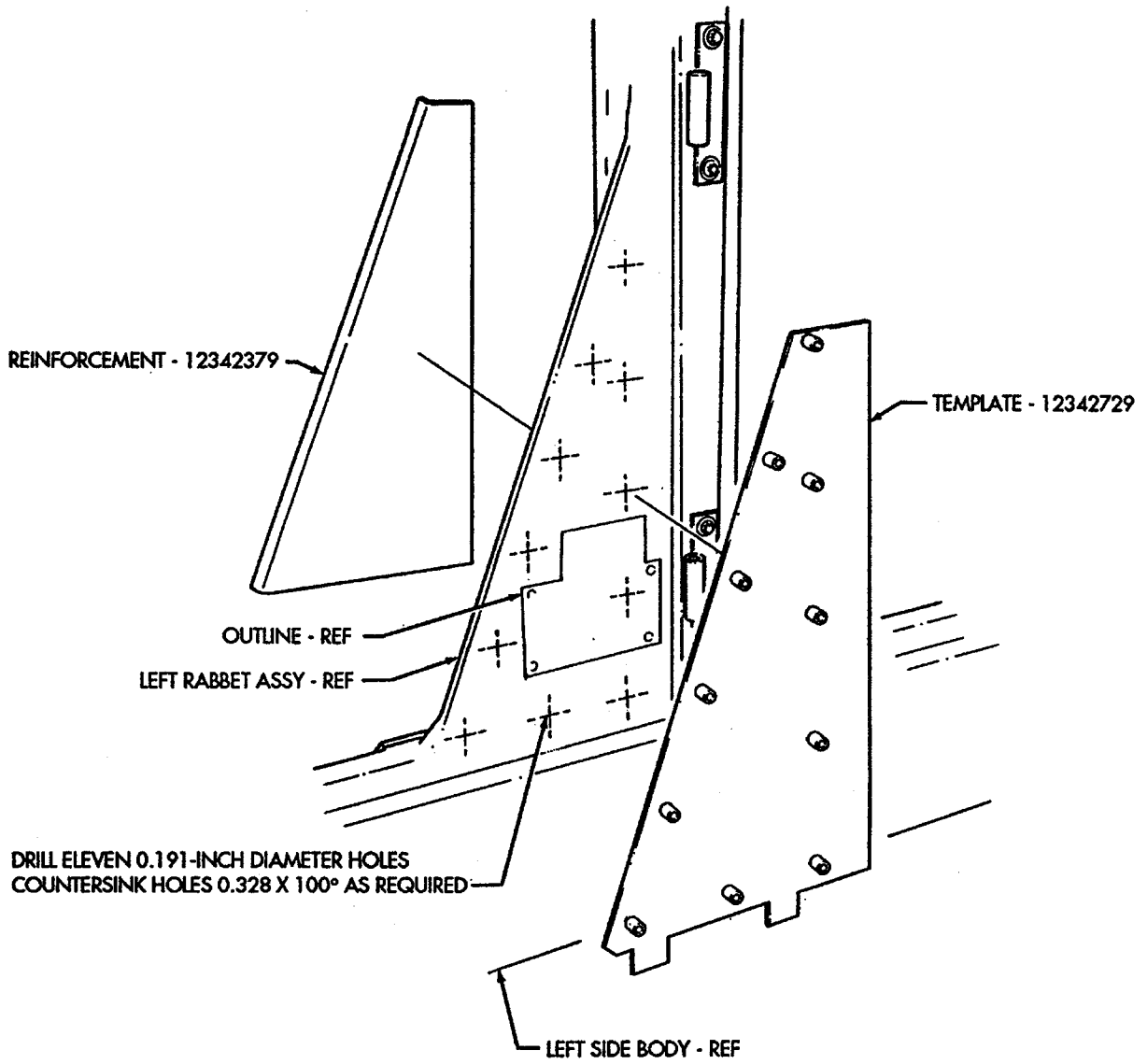

FIGURE 3

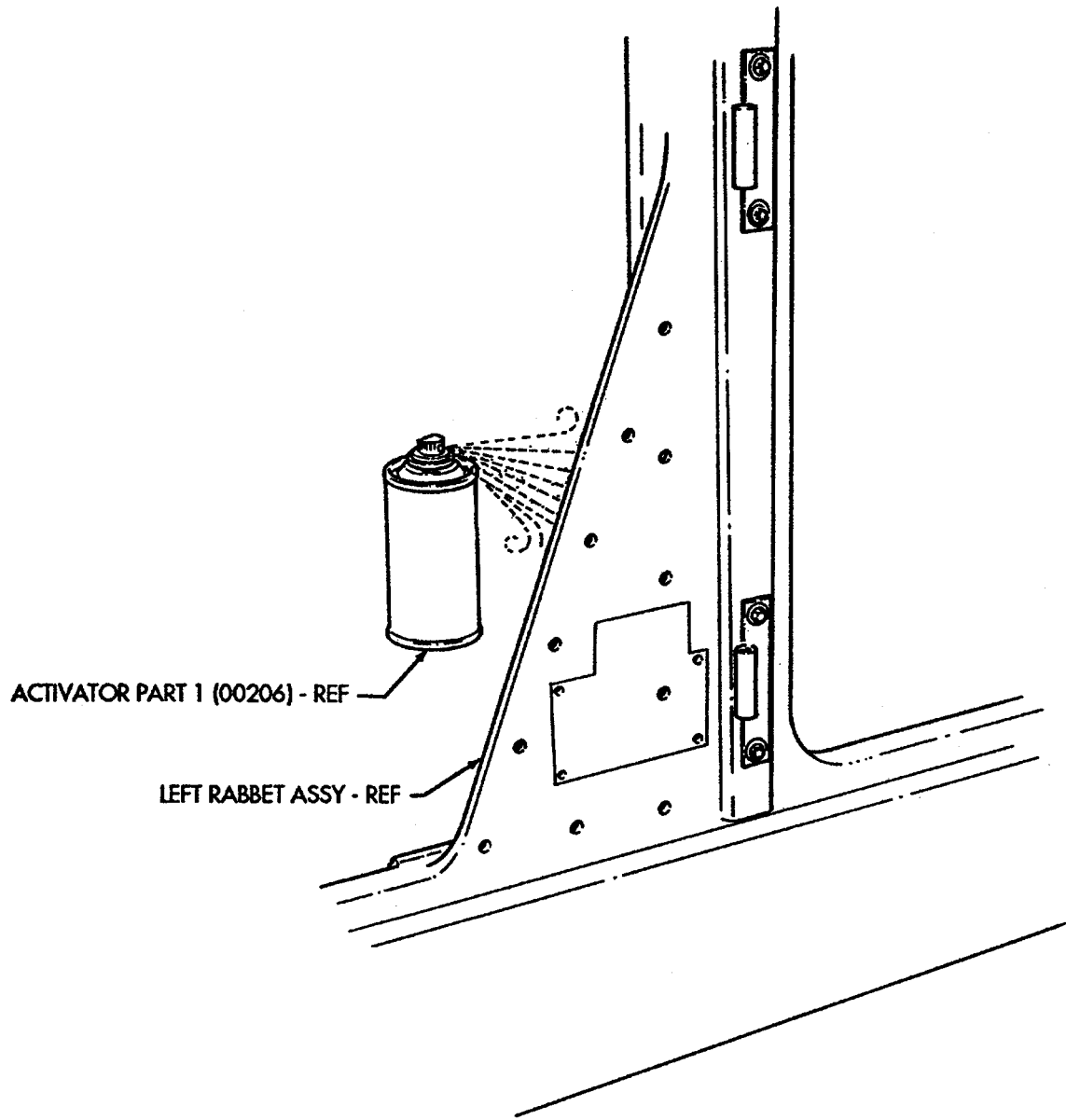

FIGURE 4

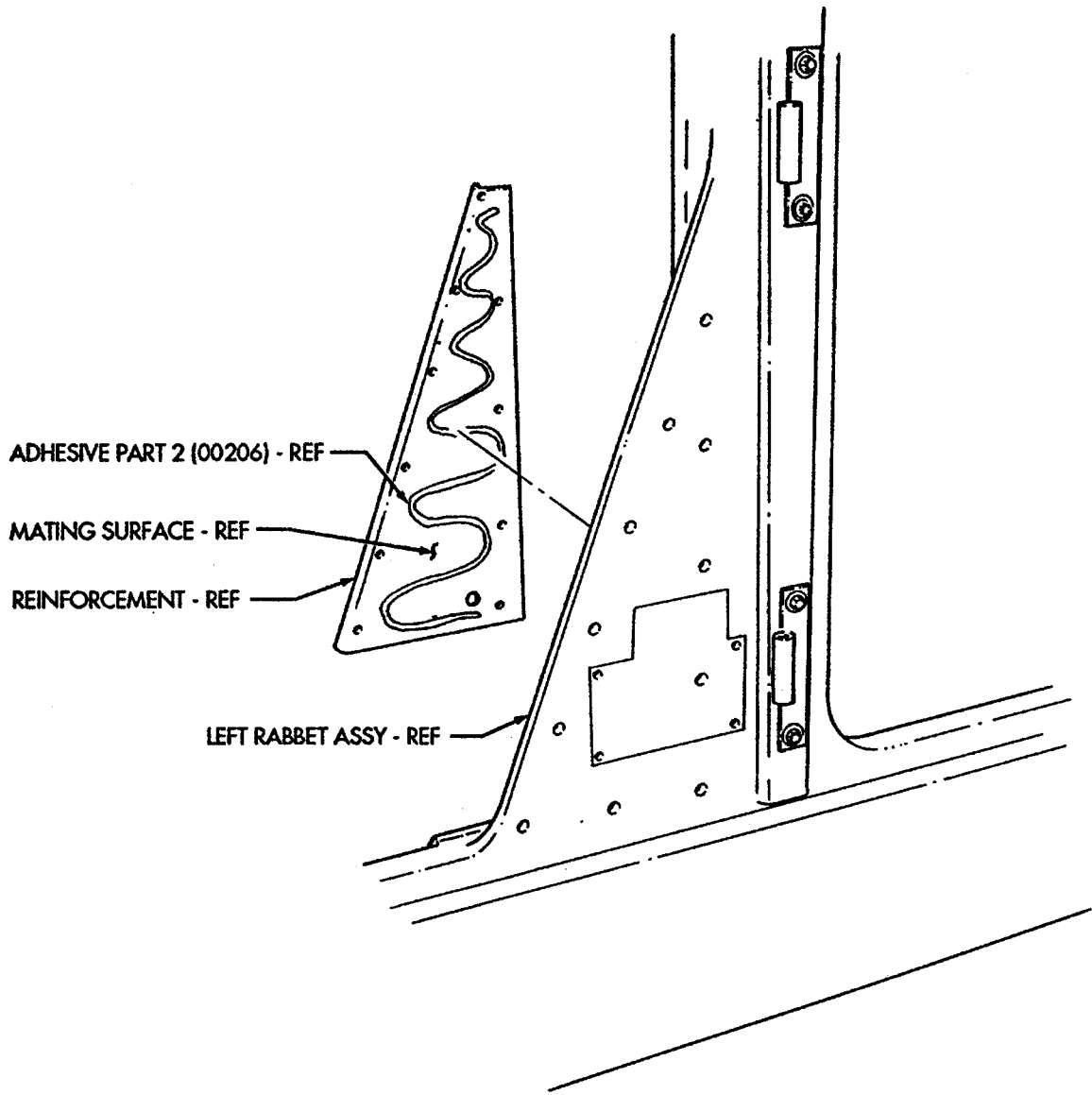

FIGURE 5

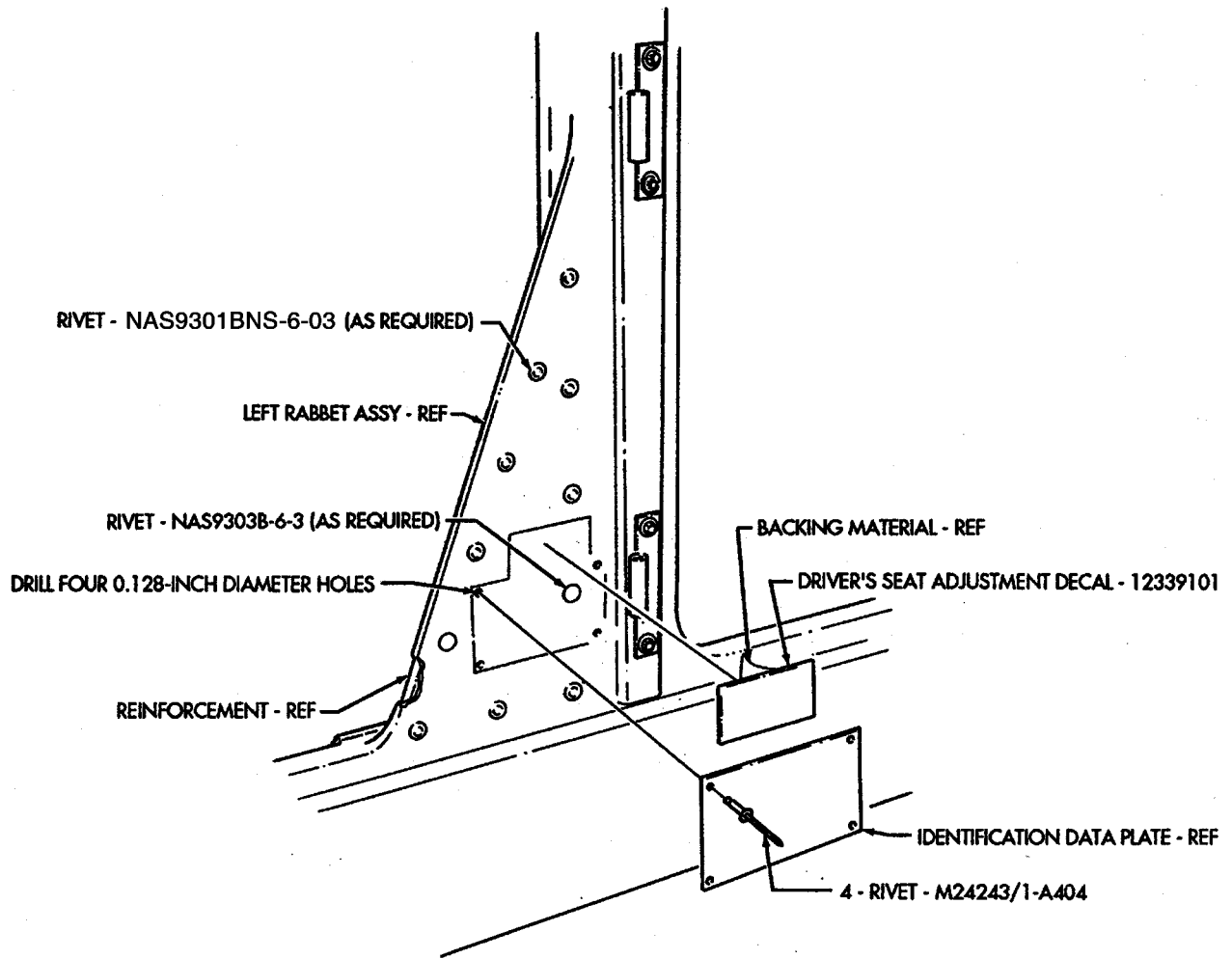
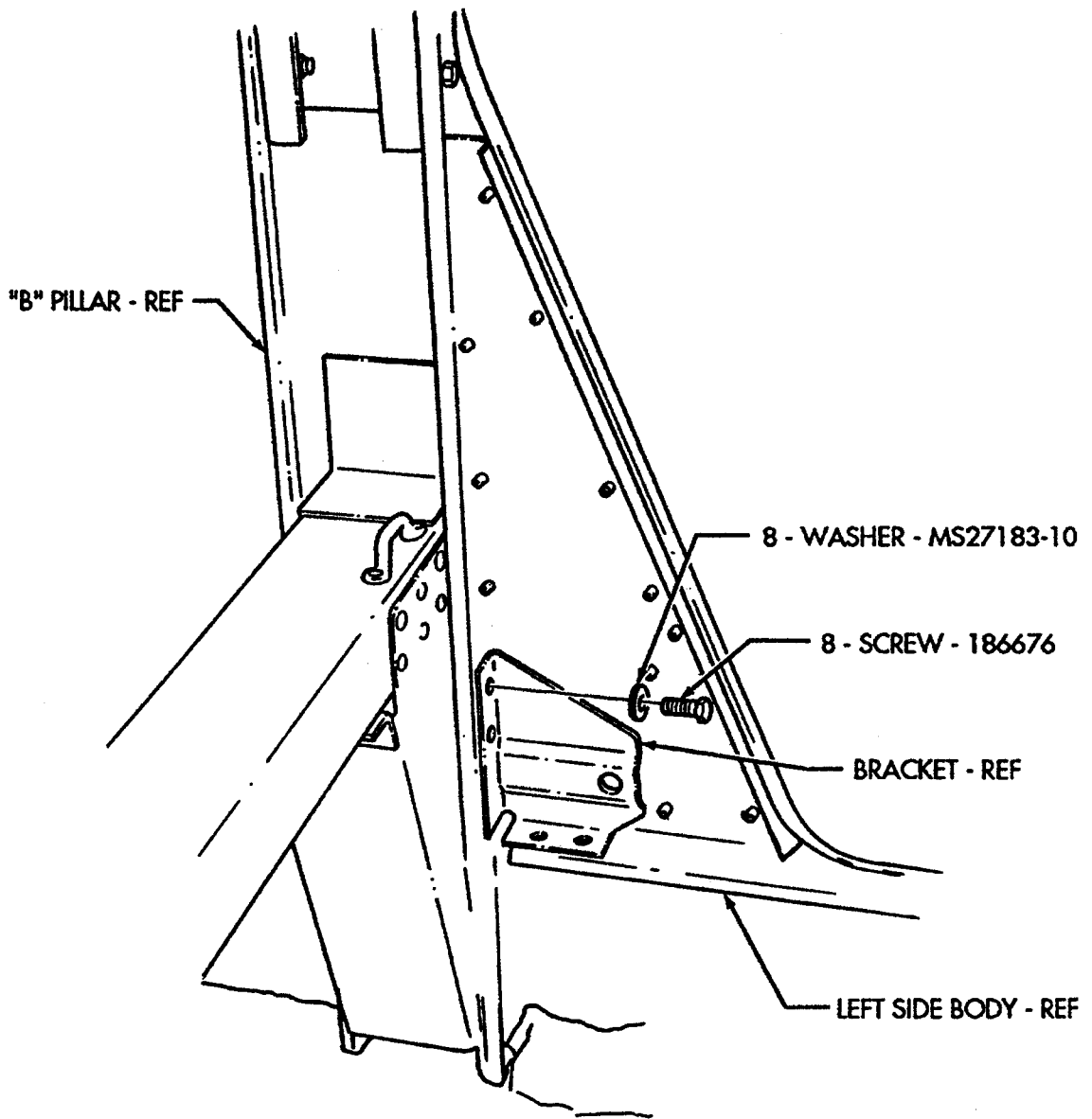
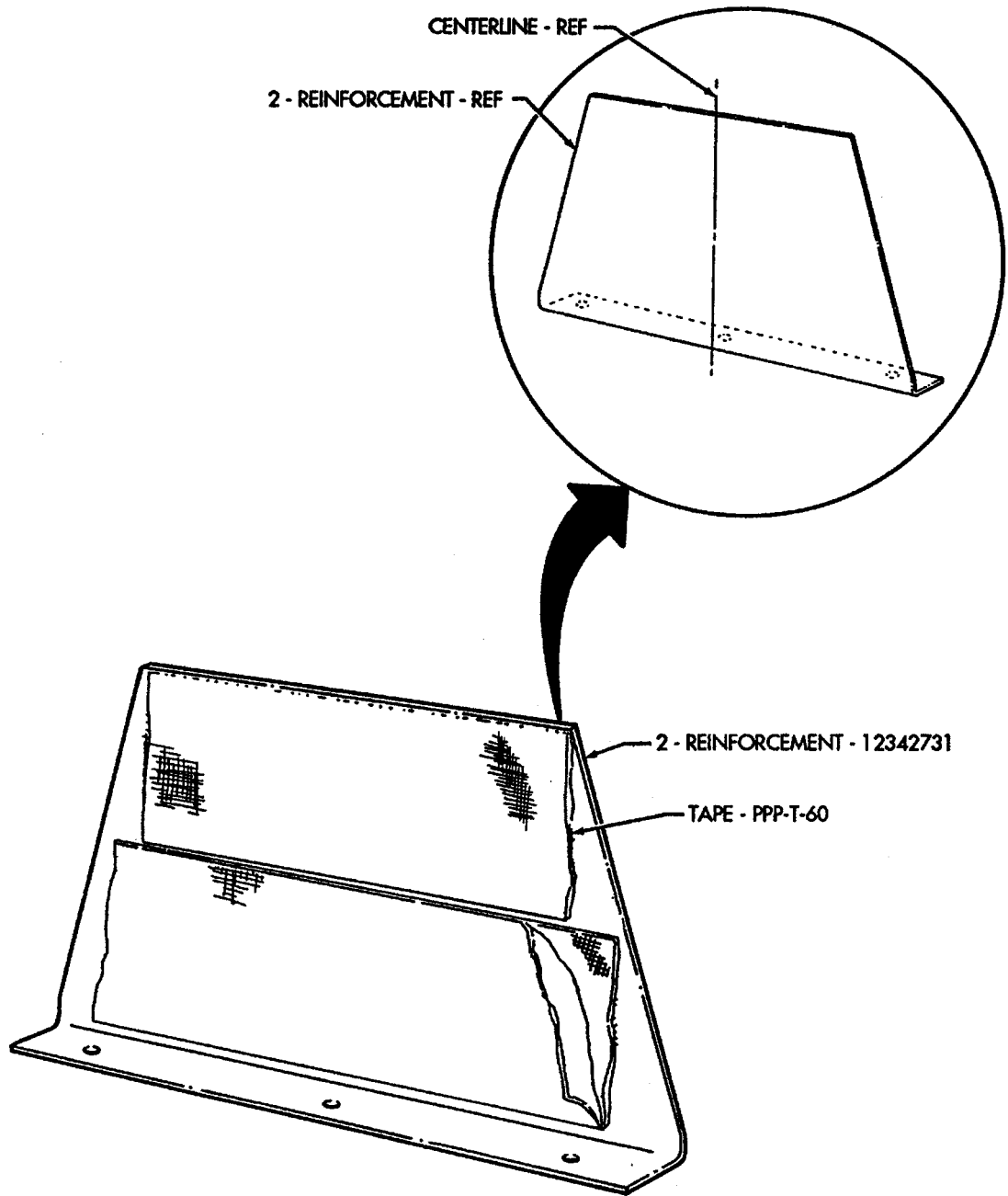

FIGURE 6



(LEFT SIDE SHOWN, RIGHT SIDE OPPOSITE)

FIGURE 7



(LEFT SIDE SHOWN, RIGHT SIDE OPPOSITE)

FIGURE 8

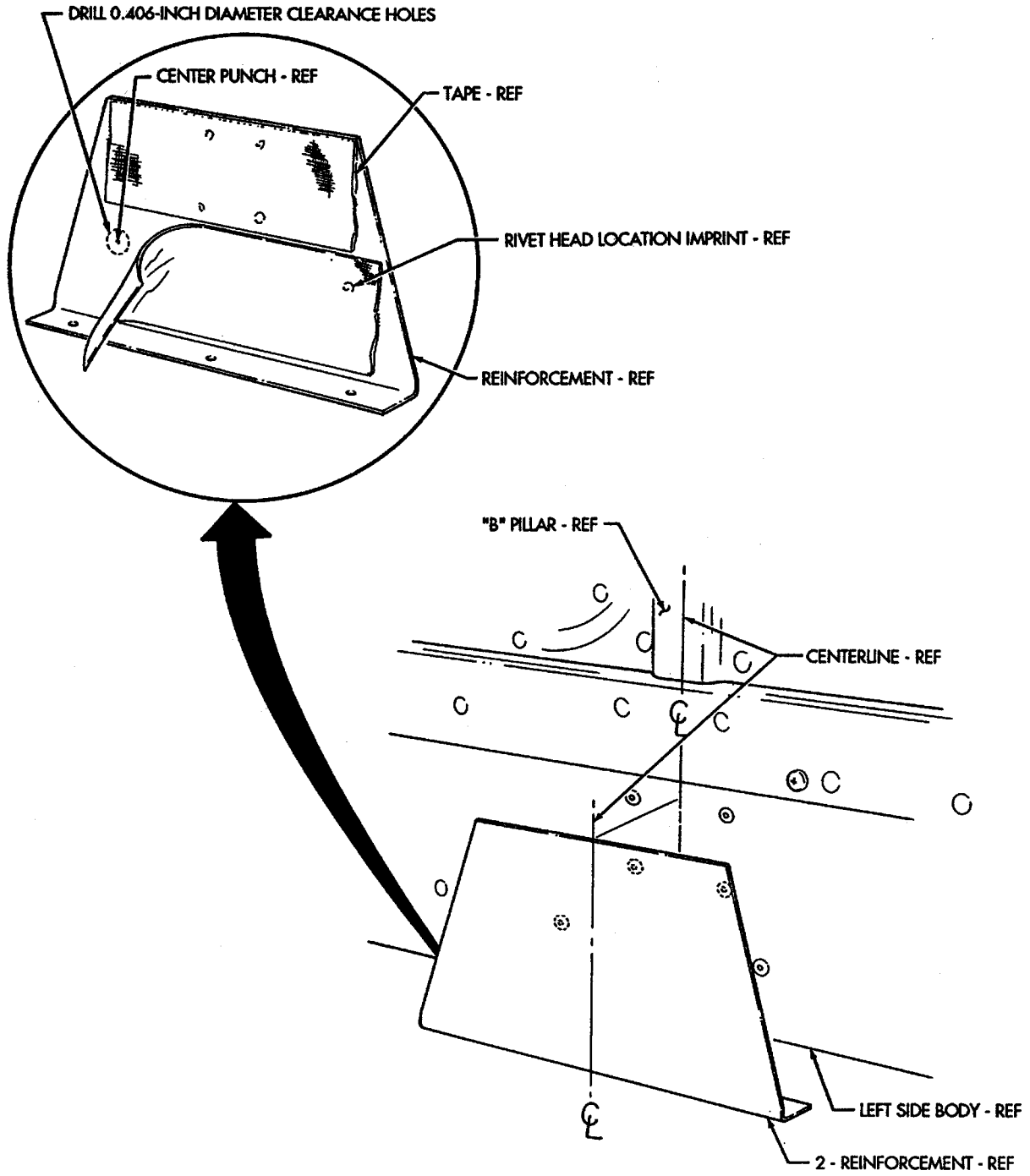

(LEFT SIDE SHOWN, RIGHT SIDE OPPOSITE)

FIGURE 9

ALL DIMENSIONS ARE IN INCHES

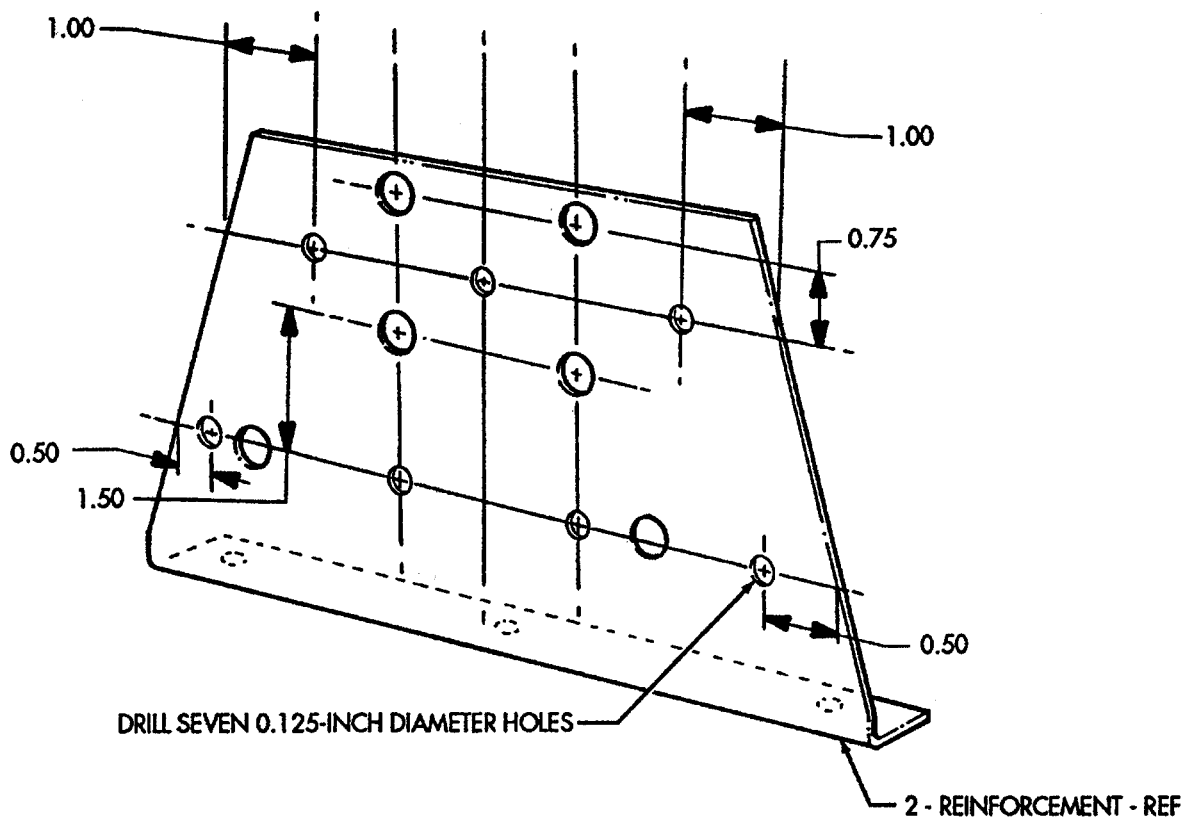

(LEFT SIDE SHOWN, RIGHT SIDE OPPOSITE)

FIGURE 10

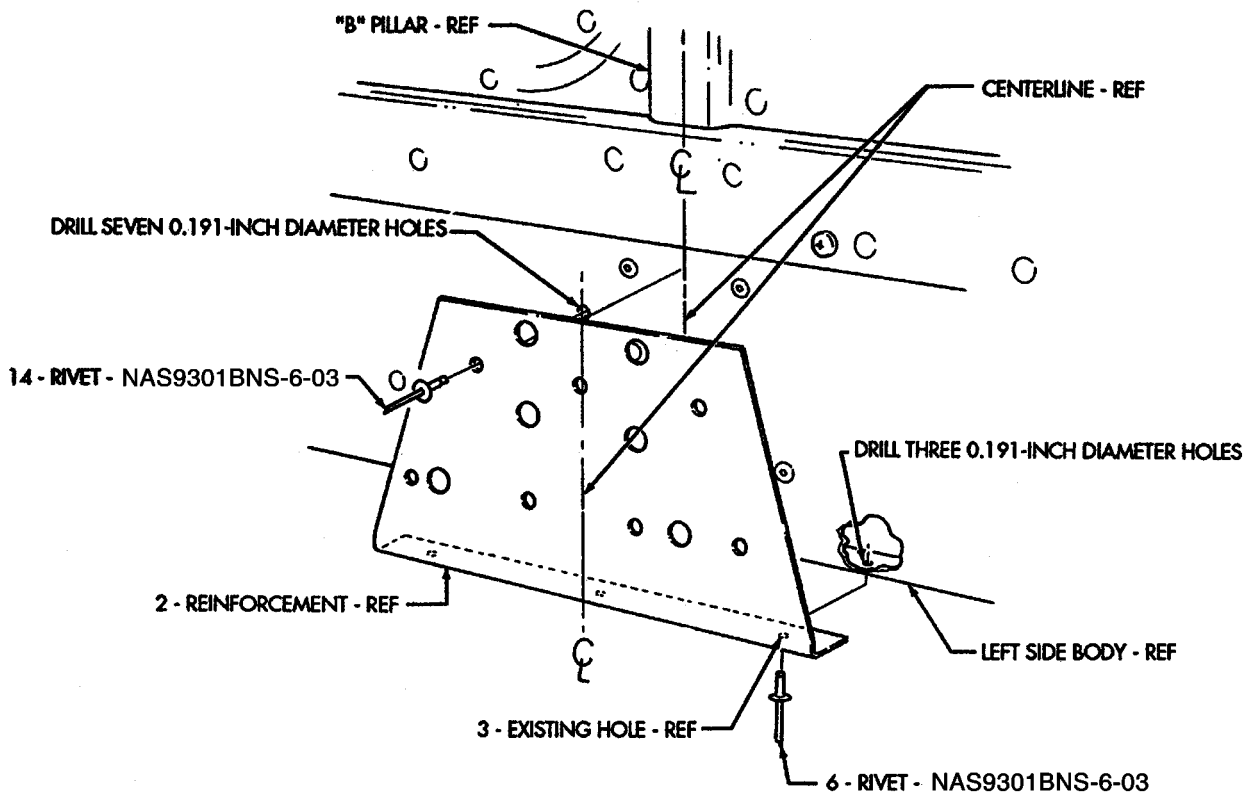

(LEFT SIDE SHOWN, RIGHT SIDE OPPOSITE)

FIGURE 11

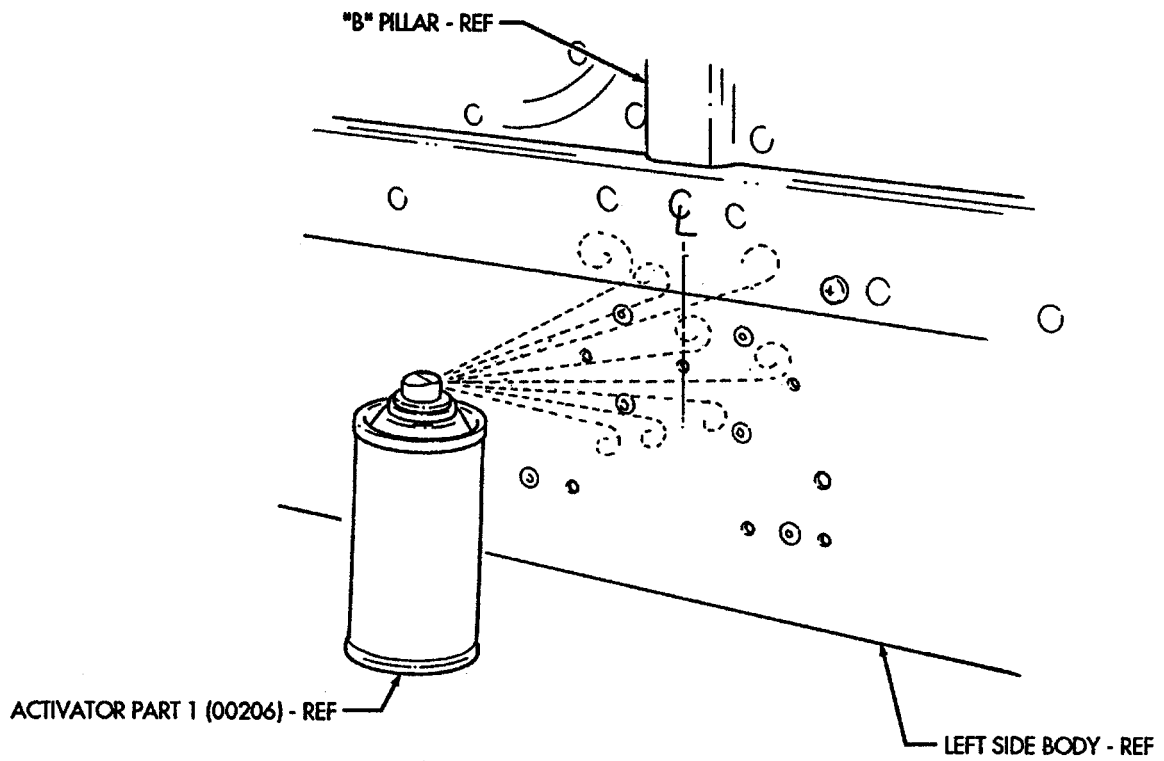

(LEFT SIDE SHOW, RIGHT SIDE OPPOSITE)

FIGURE 12

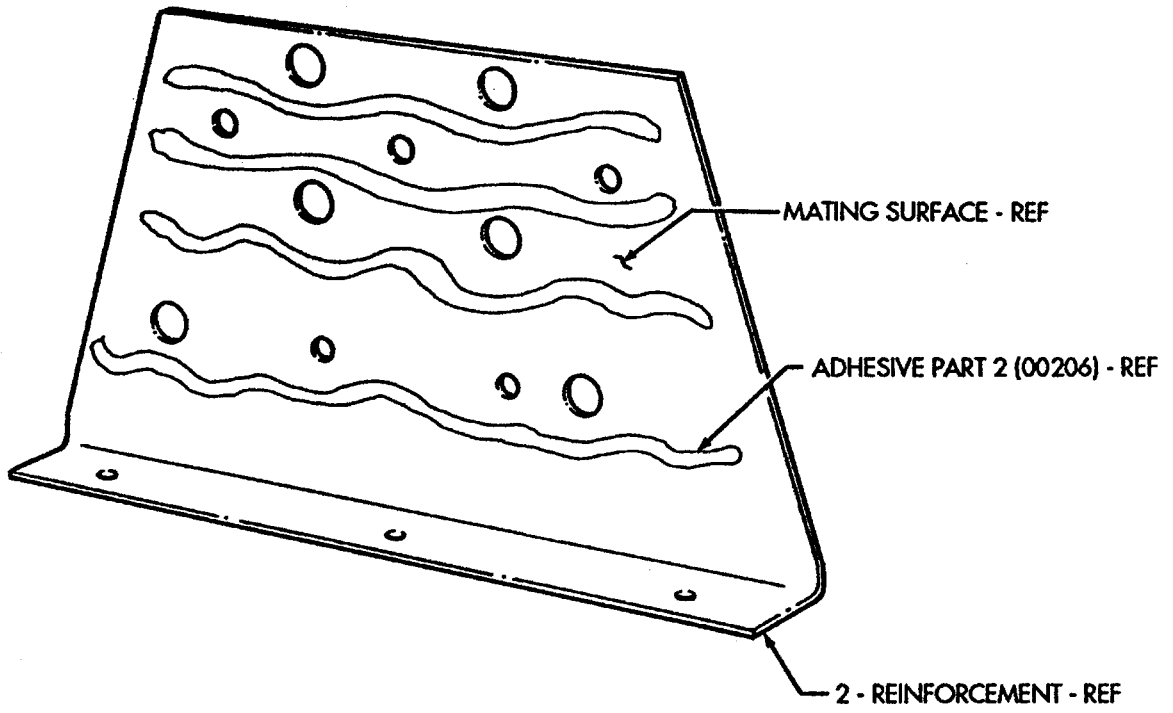

FIGURE 13

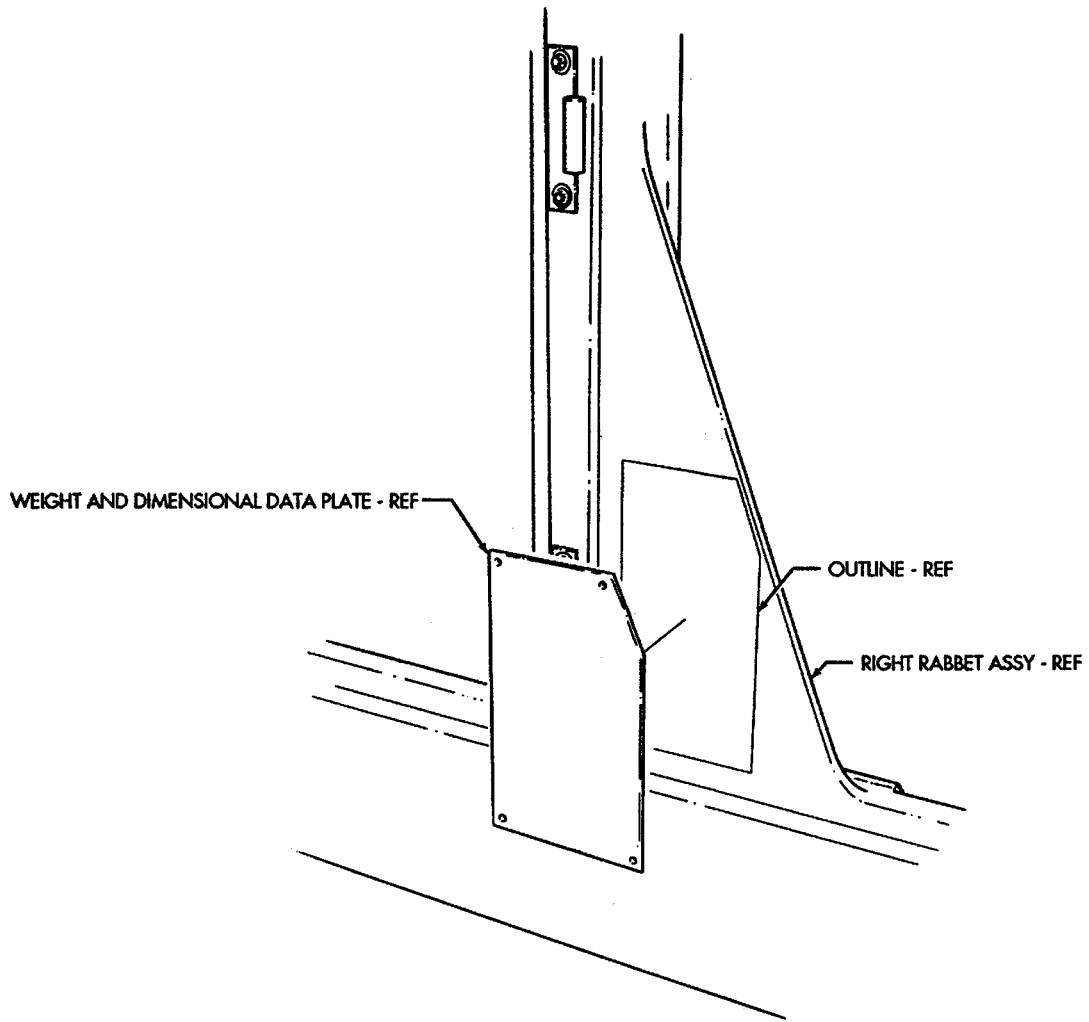

FIGURE 14

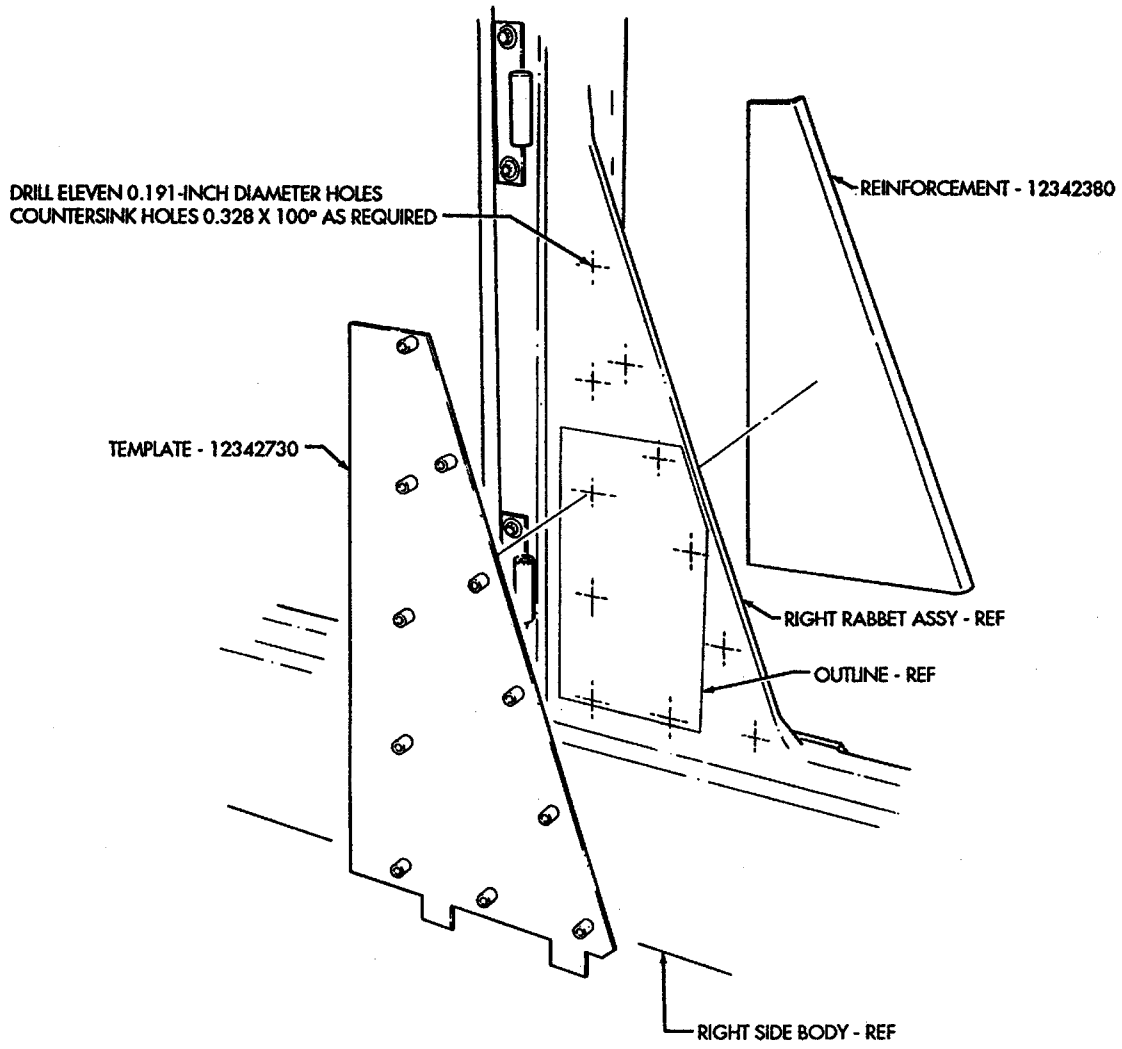

FIGURE 15

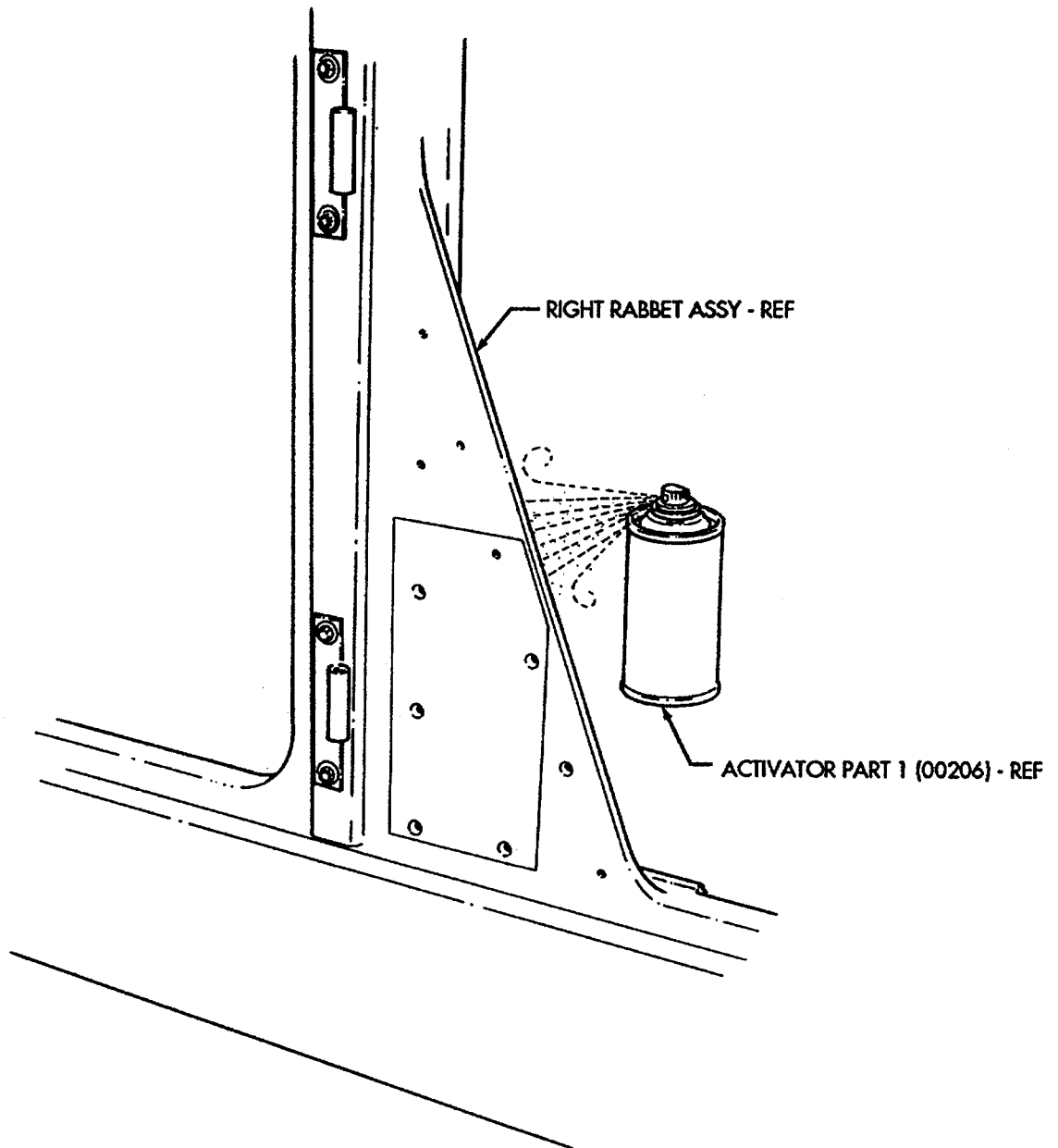

FIGURE 16

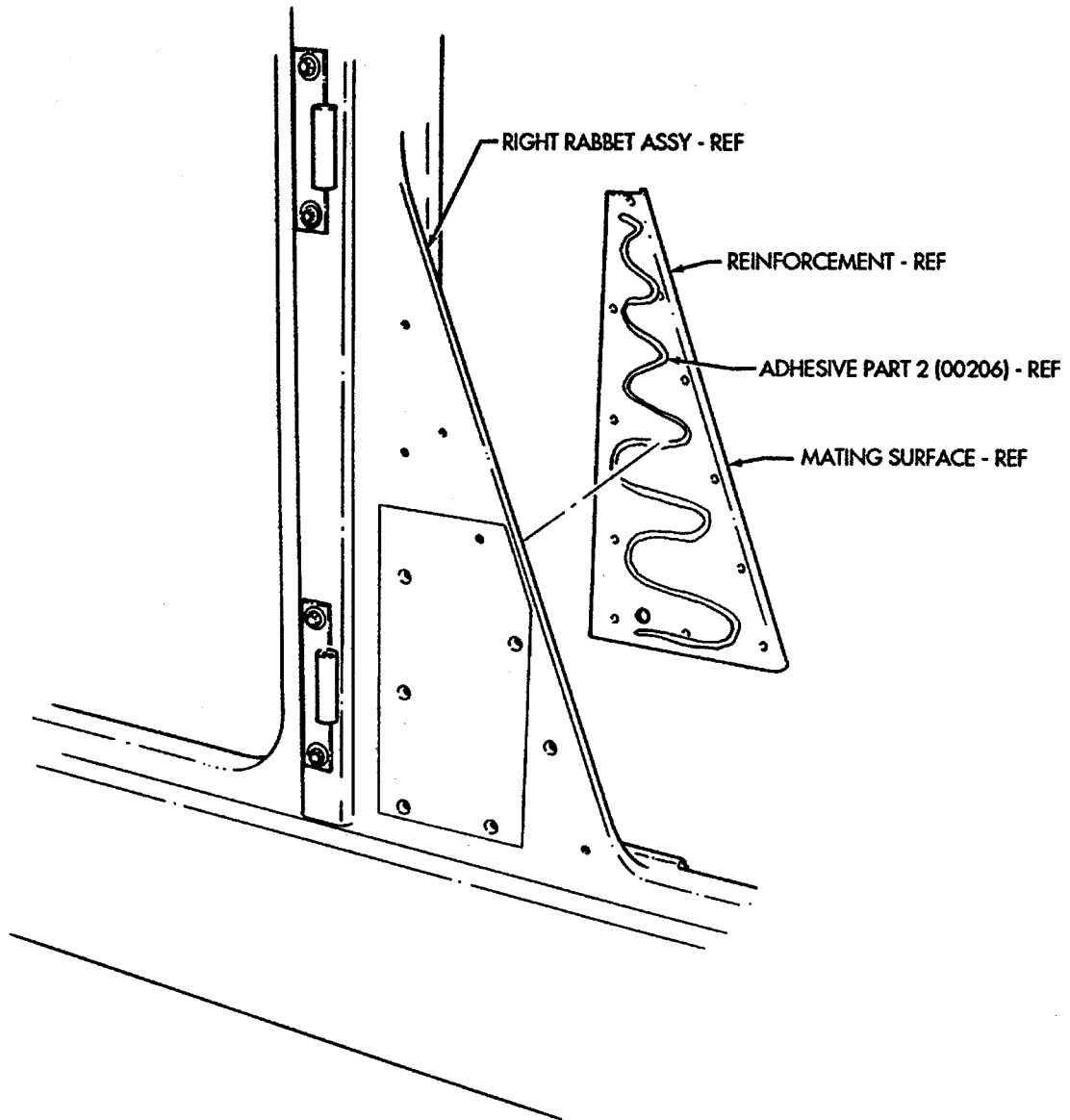

FIGURE 17

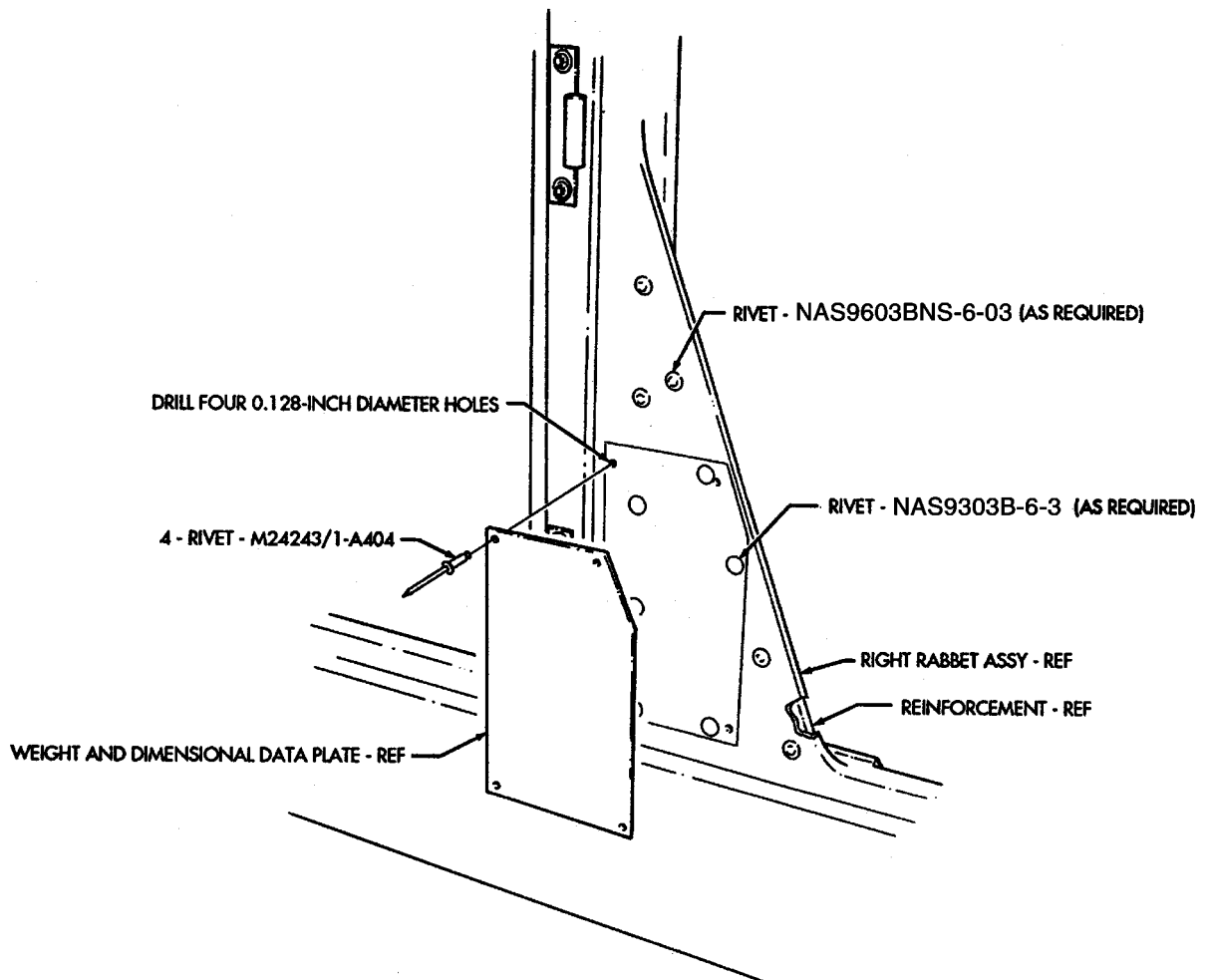

FIGURE 18

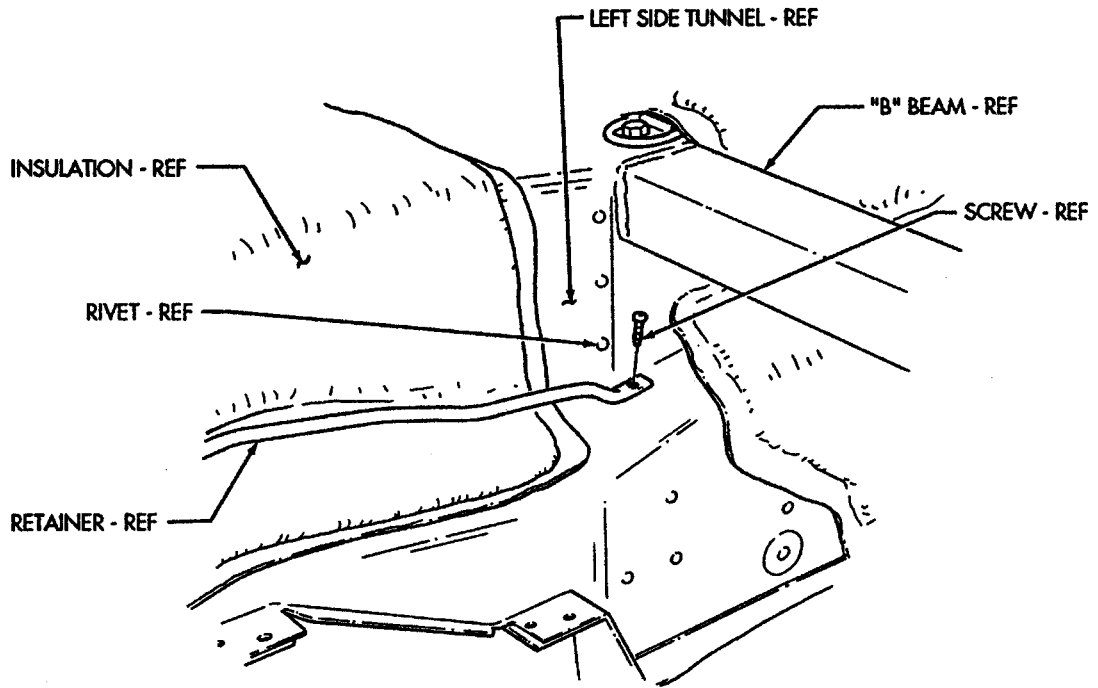

FIGURE 19

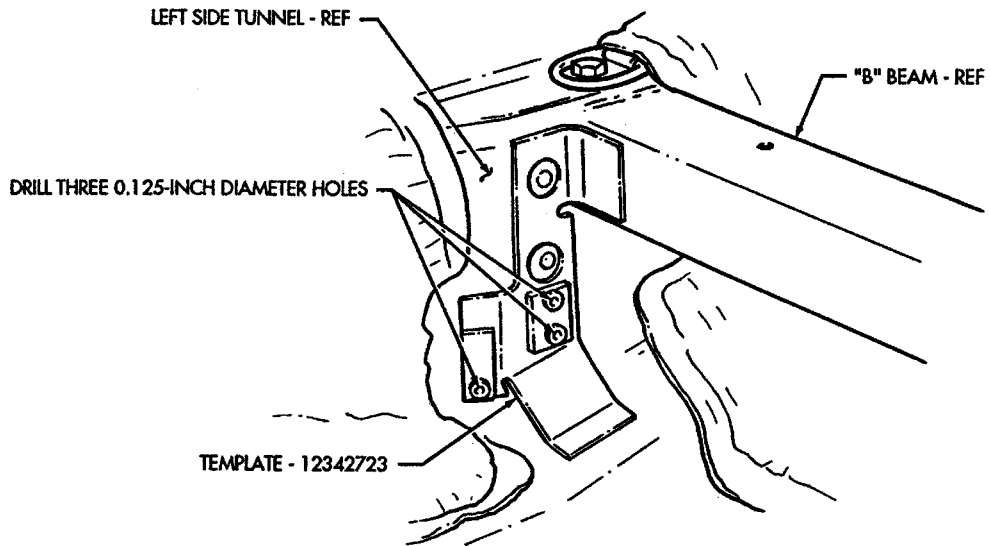

FIGURE 20

ENLARGE TWO 0.125-INCH DIAMETER HOLES TO 0.191-INCH DIAMETER

ENLARGE 0.125-INCH DIAMETER HOLE TO 0.468-INCH DIAMETER

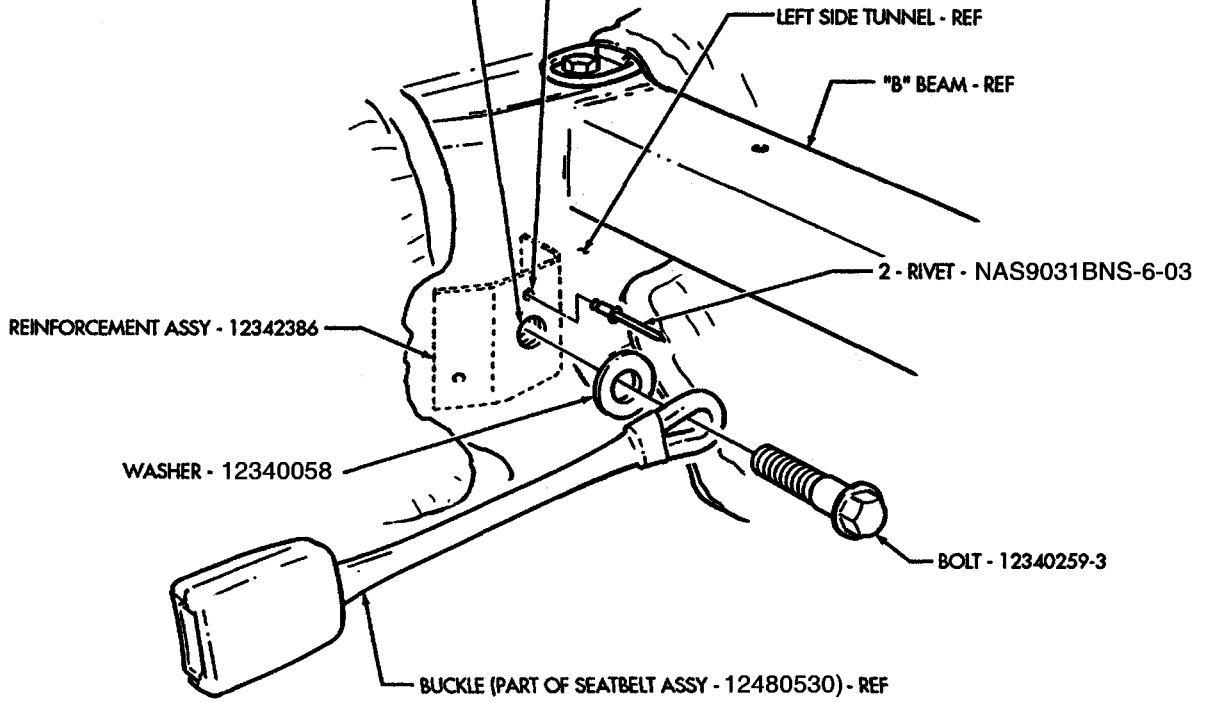

FIGURE 21

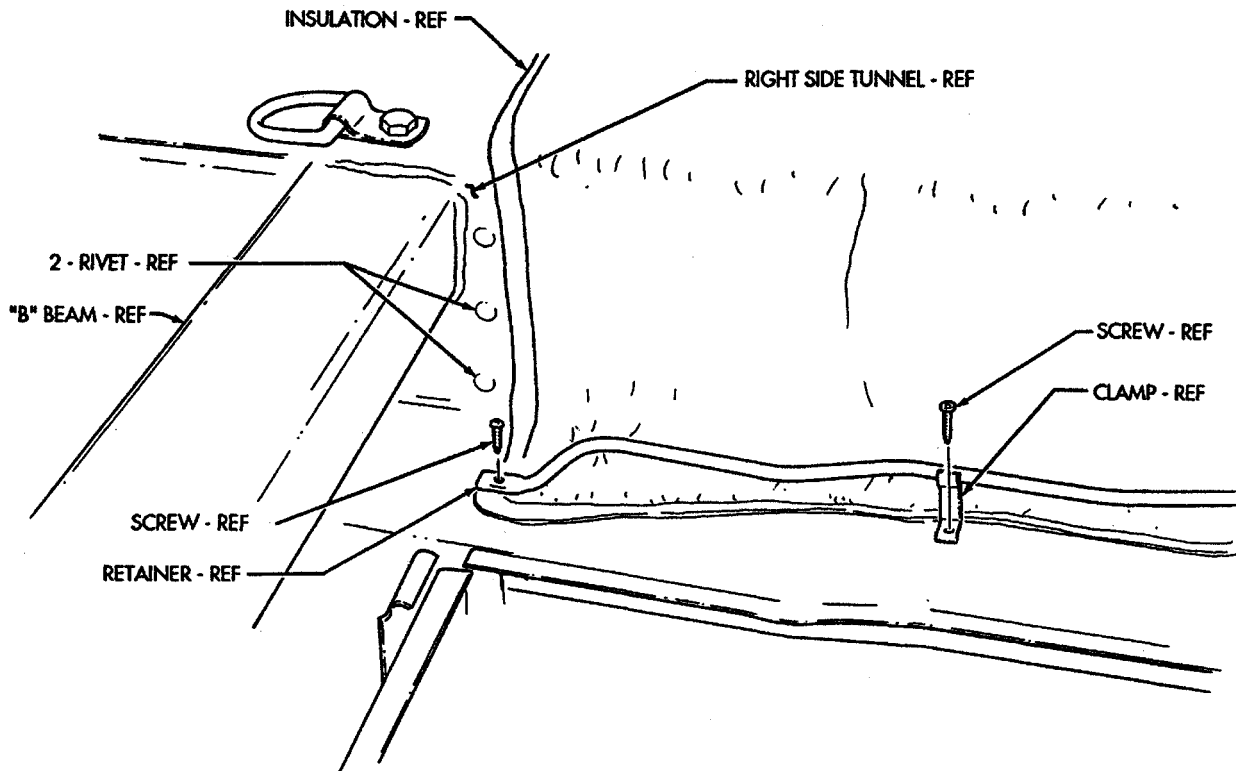

FIGURE 22

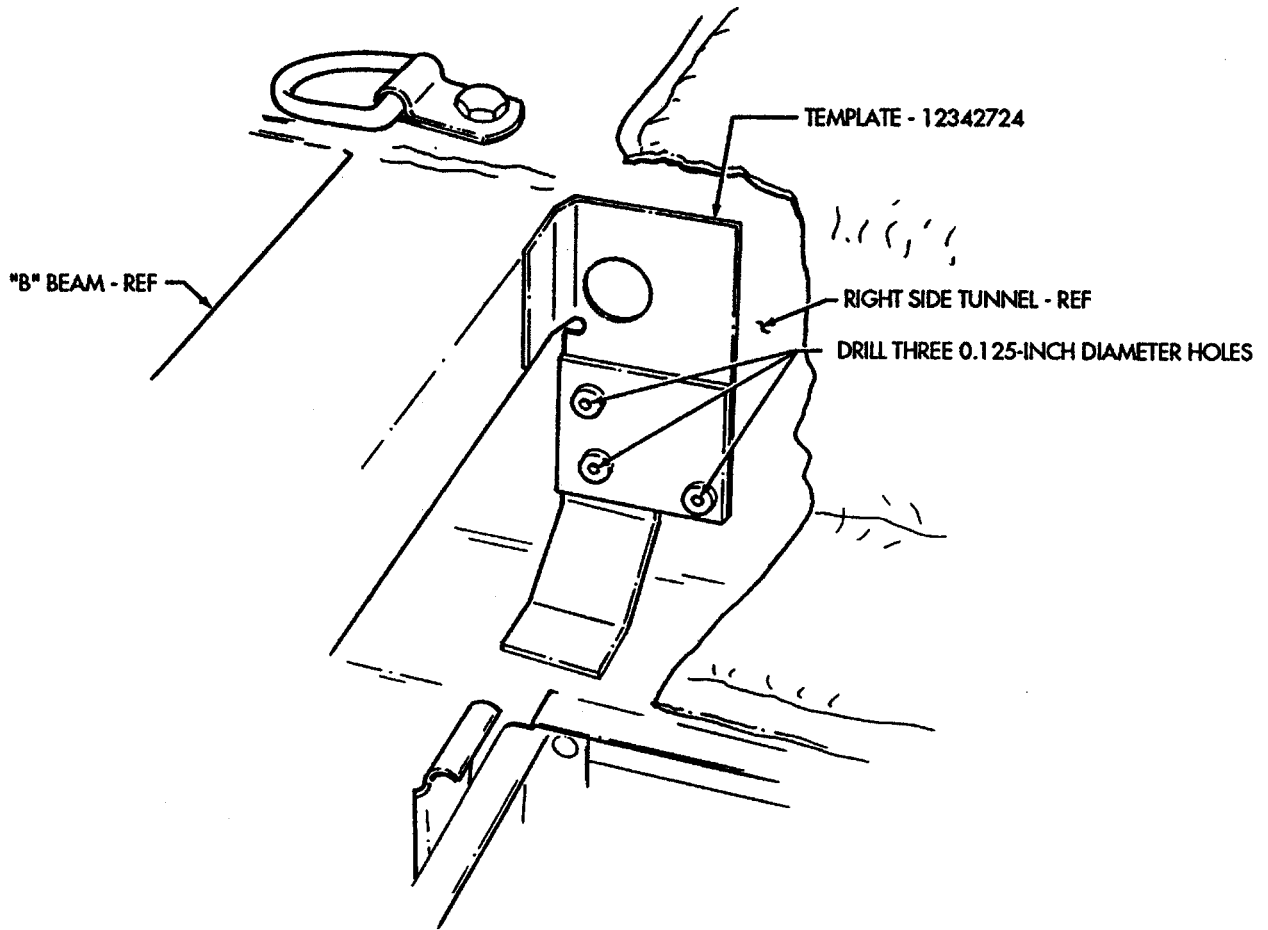

FIGURE 23

ENLARGE TWO 0.125-INCH DIAMETER HOLES TO 0.191-INCH DIAMETER

ENLARGE 0.125-INCH DIAMETER HOLE TO 0.468-INCH DIAMETER

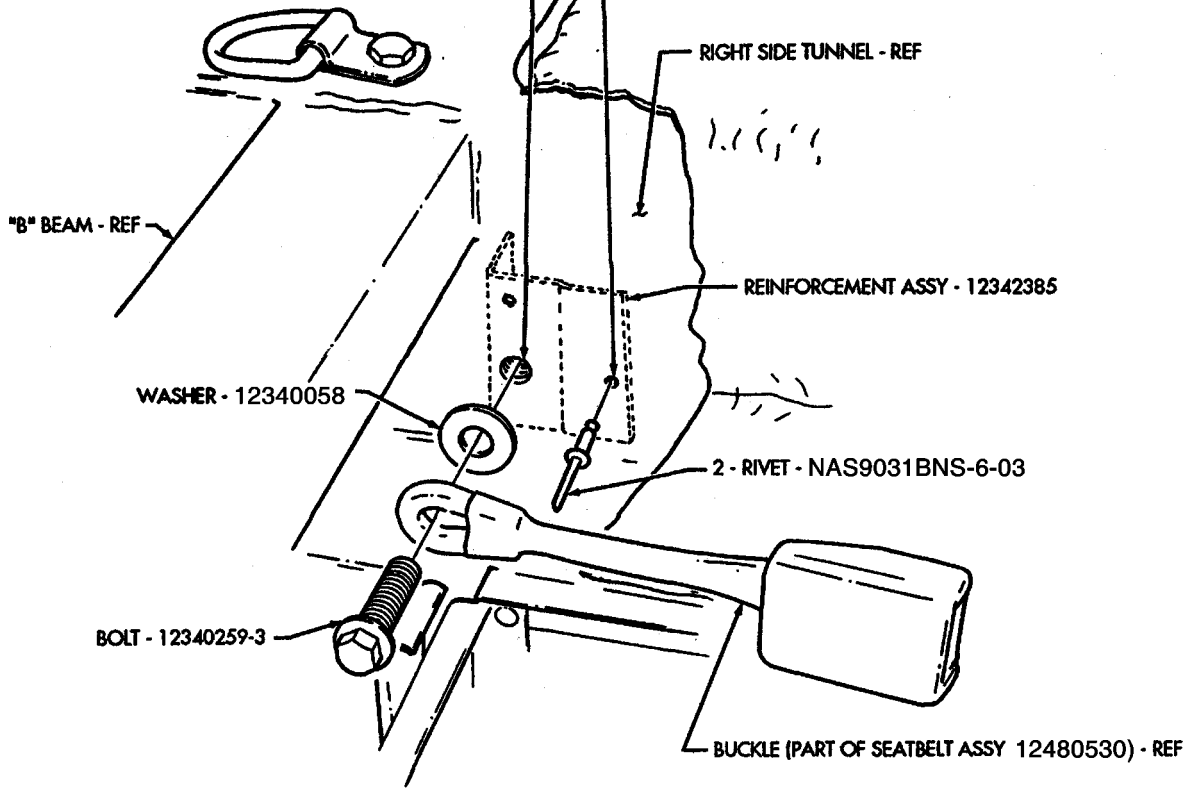
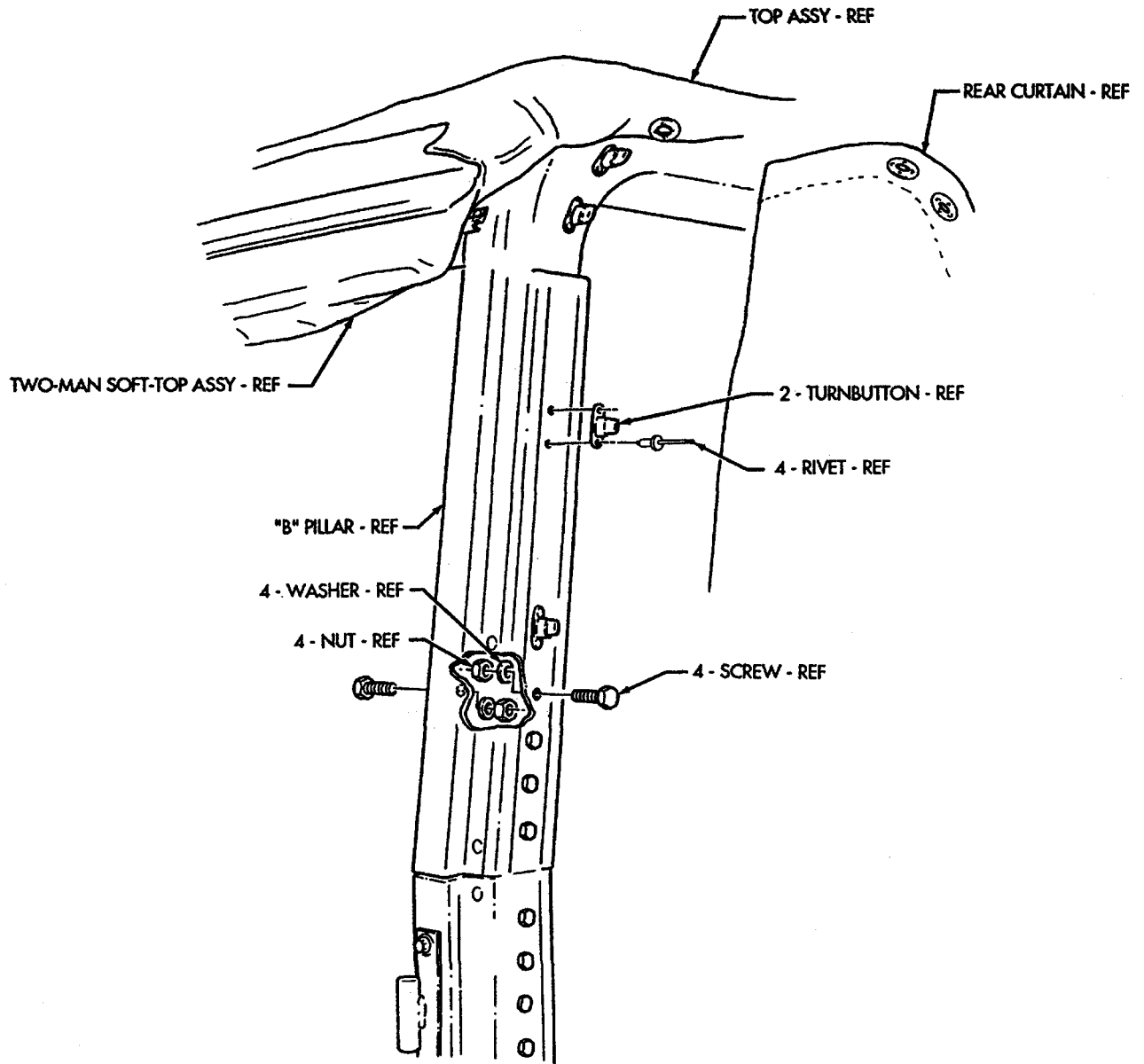
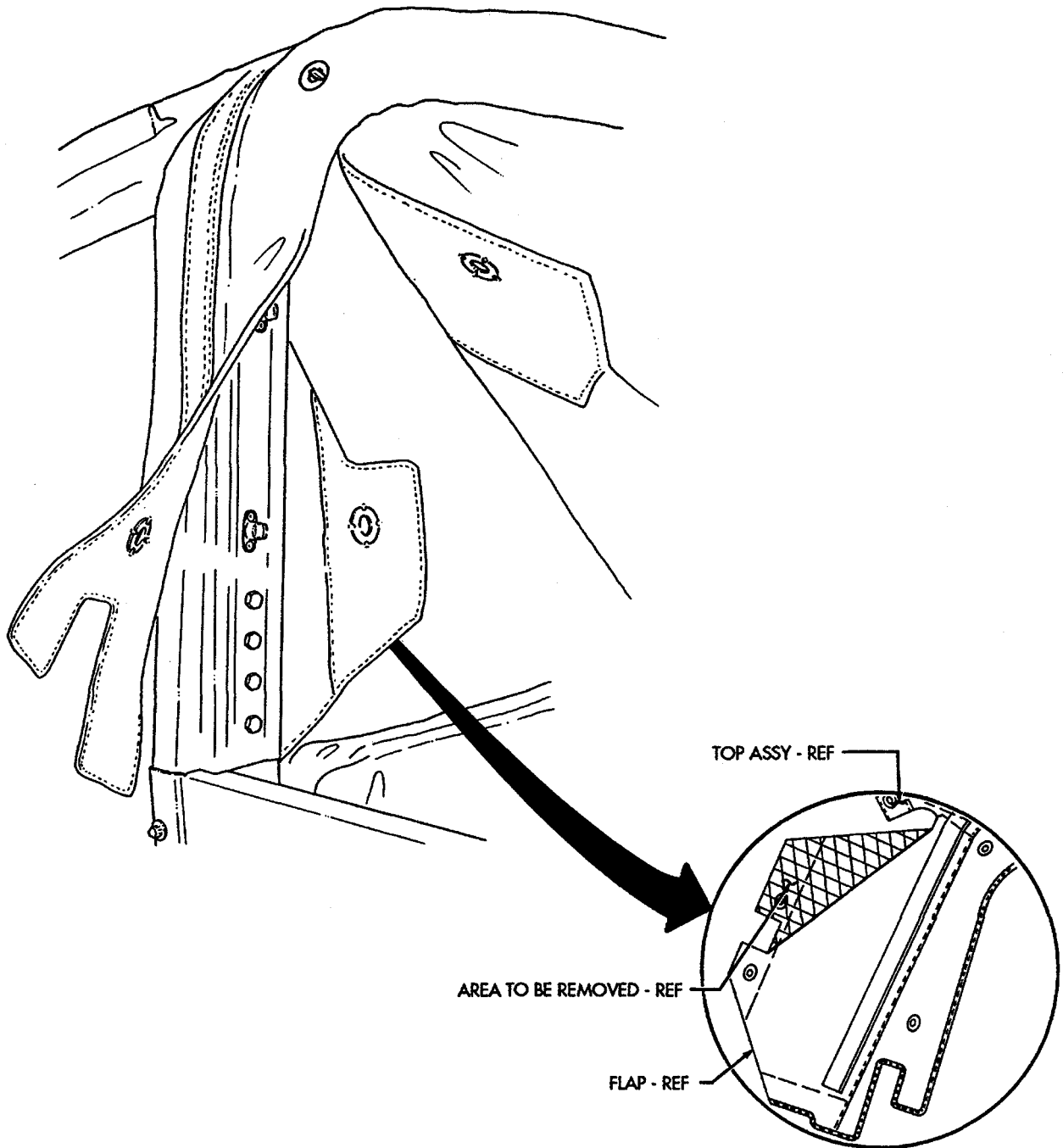

FIGURE 24



(LEFT SIDE SHOWN, RIGHT SIDE OPPOSITE)

FIGURE 25



(LEFT SIDE SHOWN, RIGHT SIDE OPPOSITE)

FIGURE 26

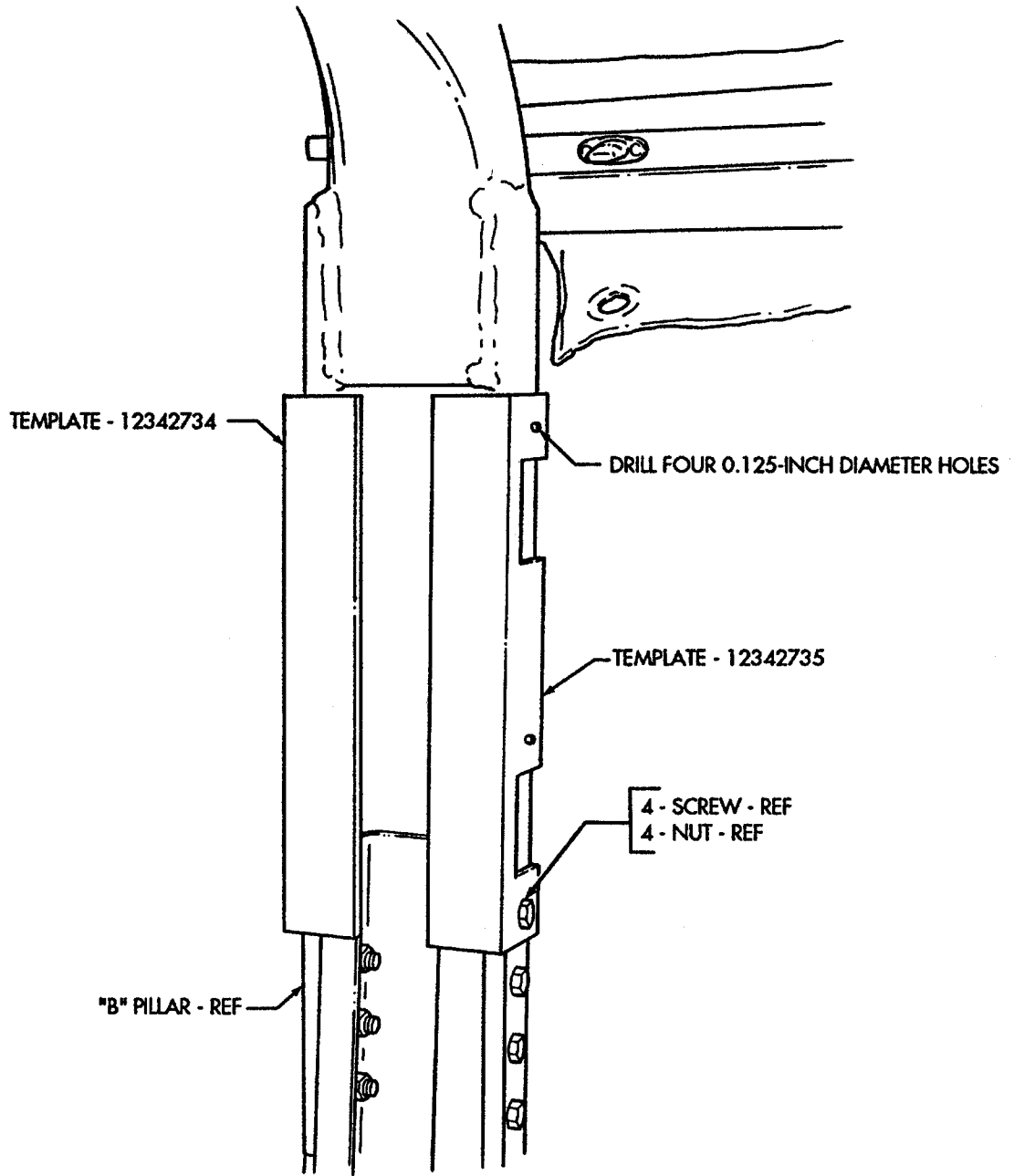

(LEFT SIDE SHOWN, RIGHT SIDE OPPOSITE)

FIGURE 27

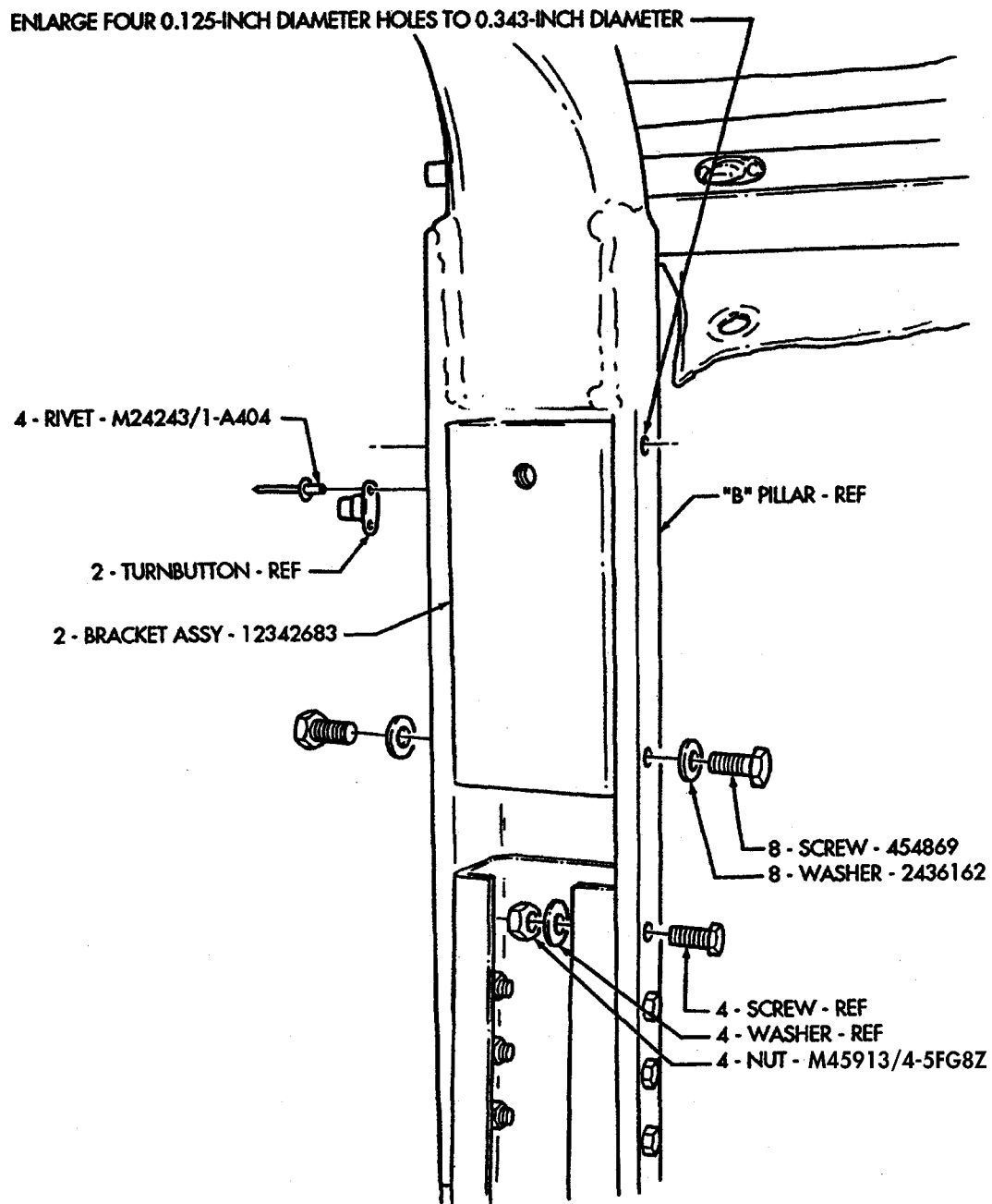

(LEFT SIDE SHOWN, RIGHT SIDE OPPOSITE)

FIGURE 28

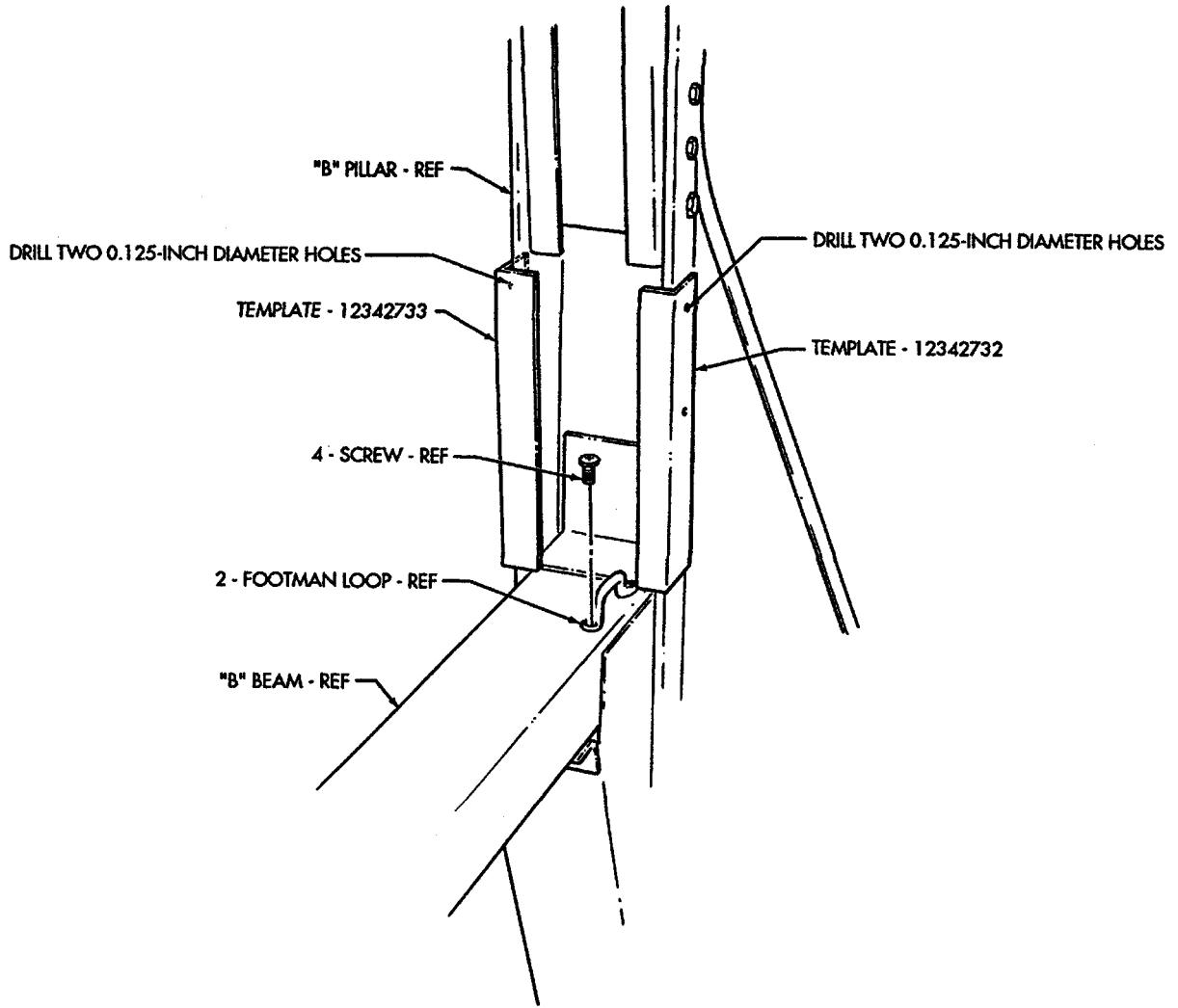

(LEFT SIDE SHOWN, RIGHT SIDE OPPOSITE)

FIGURE 29

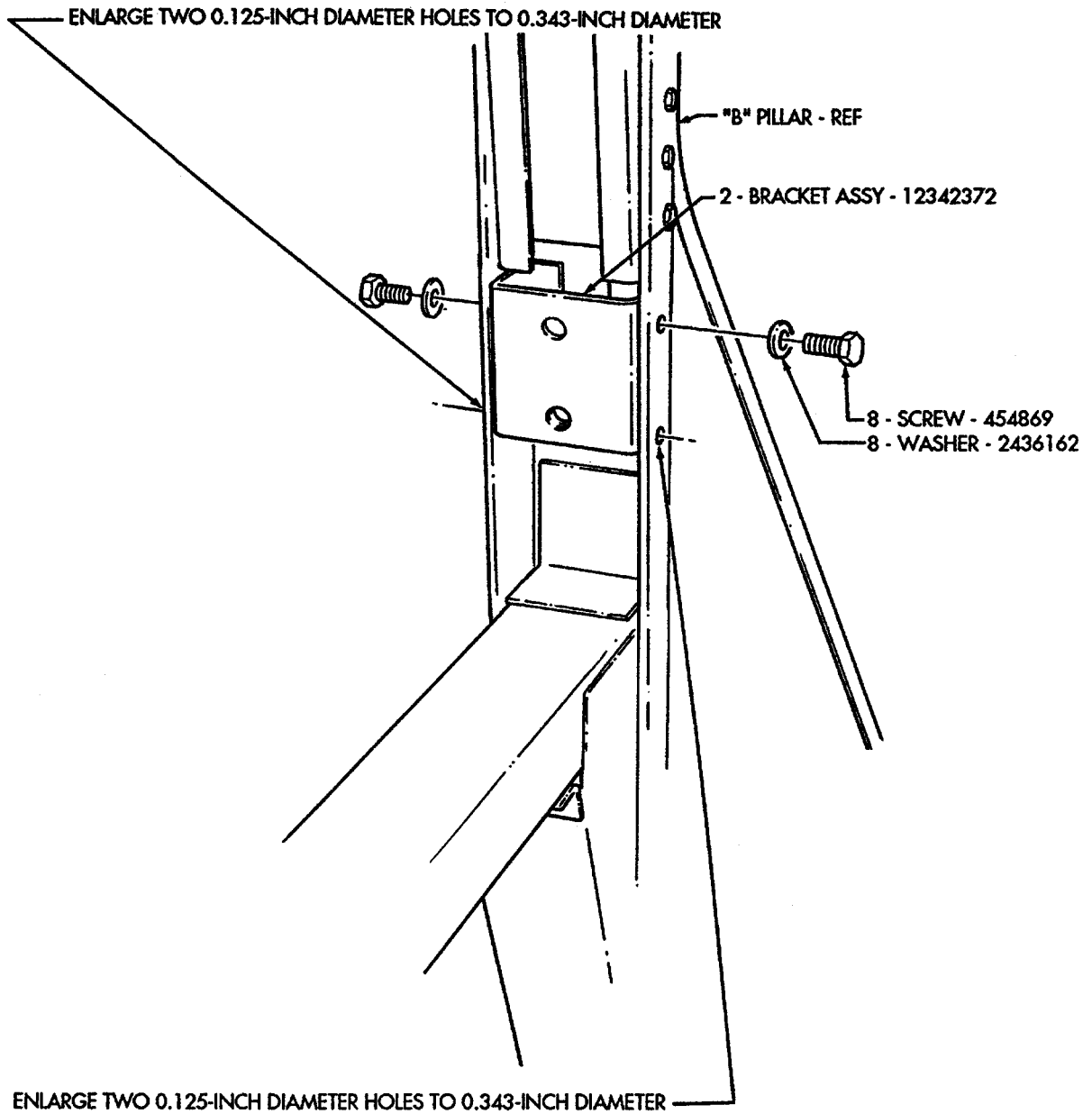

(LEFT SIDE SHOWN, RIGHT SIDE OPPOSITE)

FIGURE 30

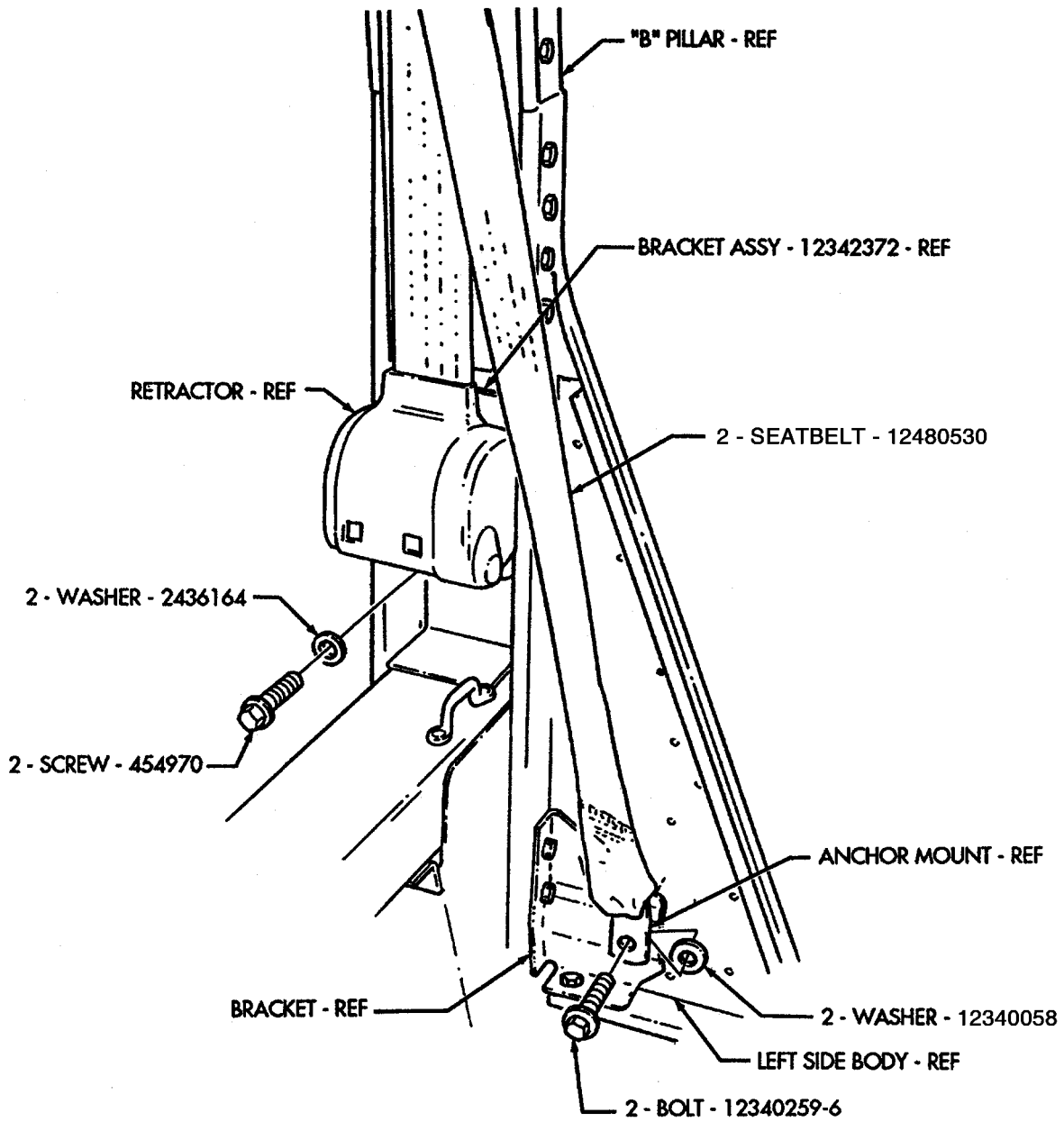

(LEFT SIDE SHOWN, RIGHT SIDE OPPOSITE)

FIGURE 31

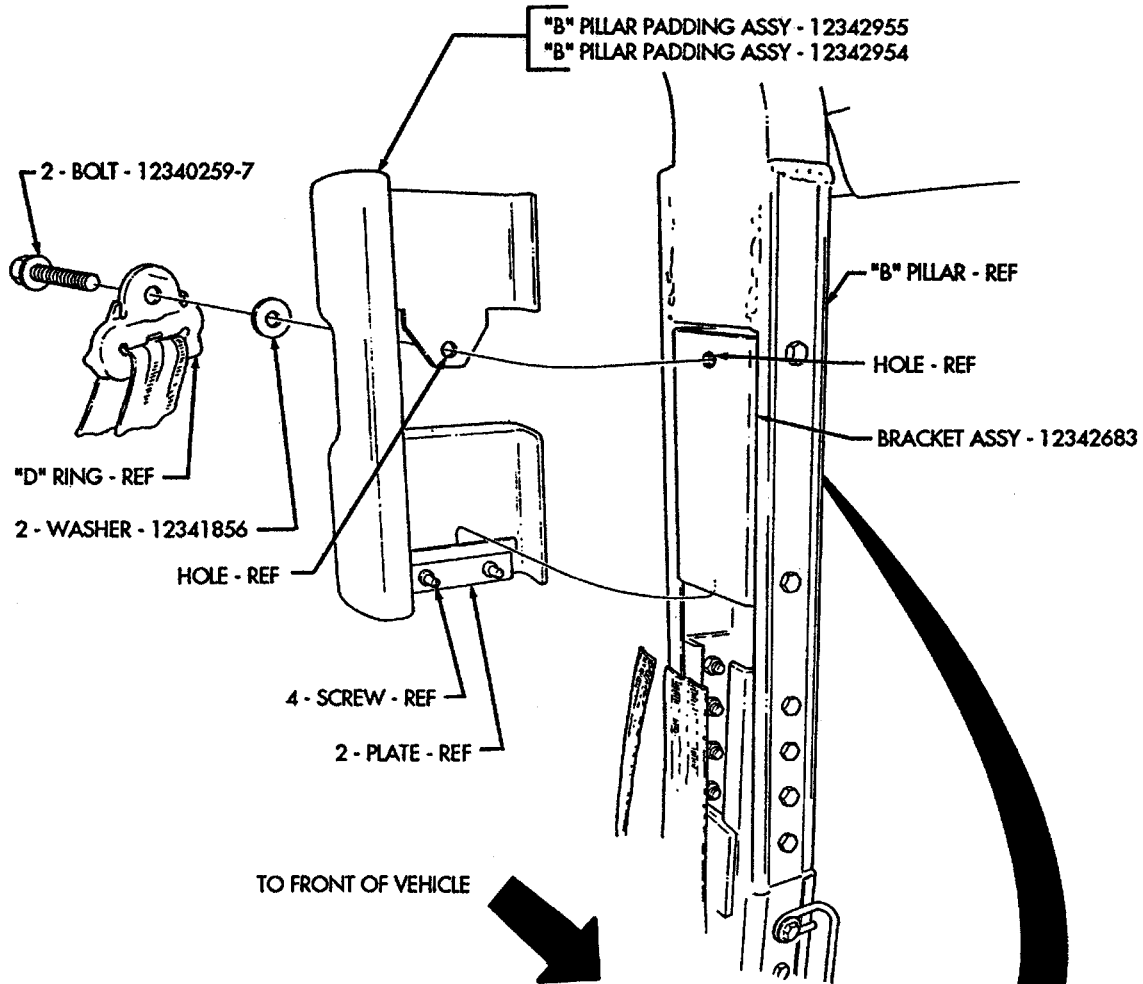

(LEFT SIDE SHOWN, RIGHT SIDE OPPOSITE)

FIGURE 32

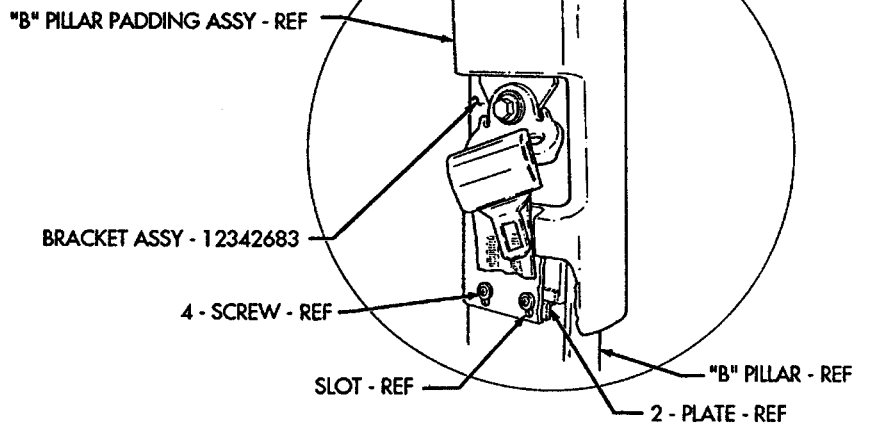

(LEFT SIDE SHOWN, RIGHT SIDE OPPOSITE)

FIGURE 32A

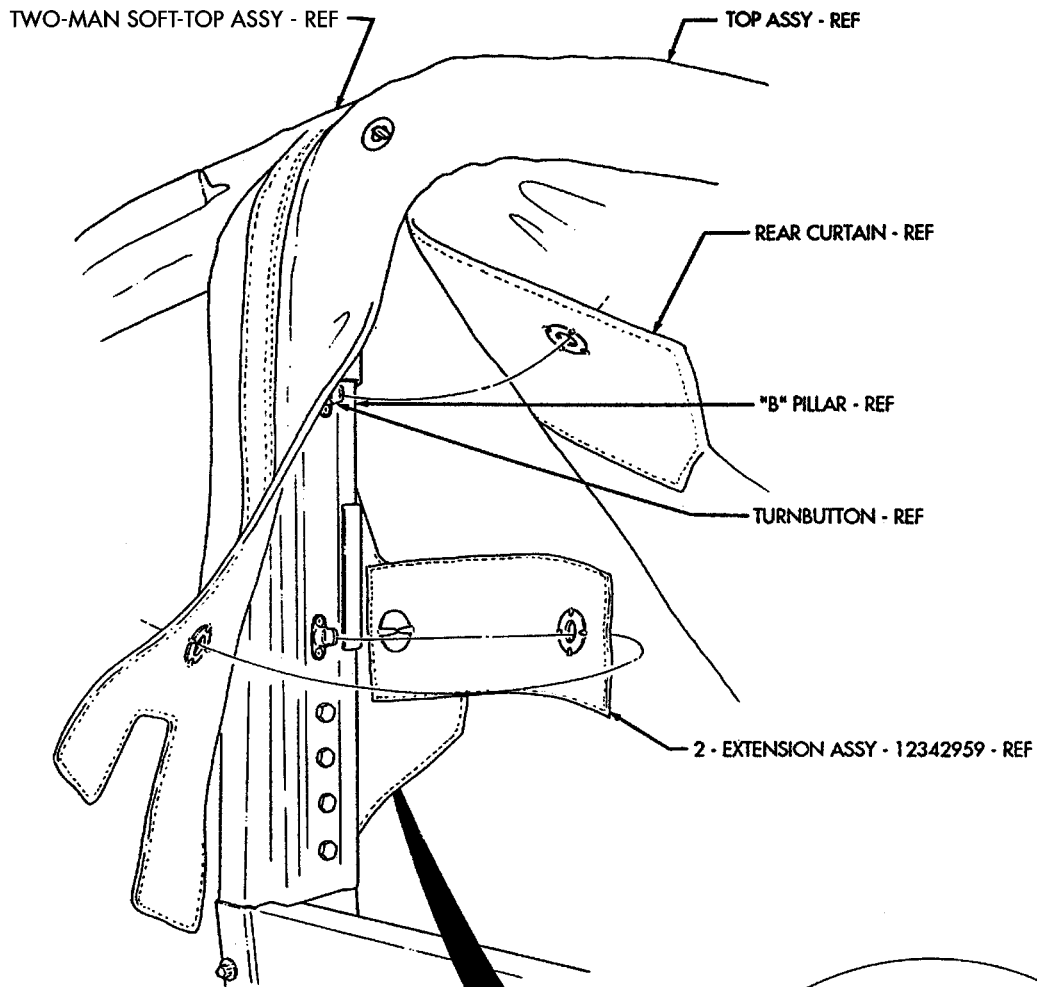

(LEFT SIDE SHOWN, RIGHT SIDE OPPOSITE)

FIGURE 33

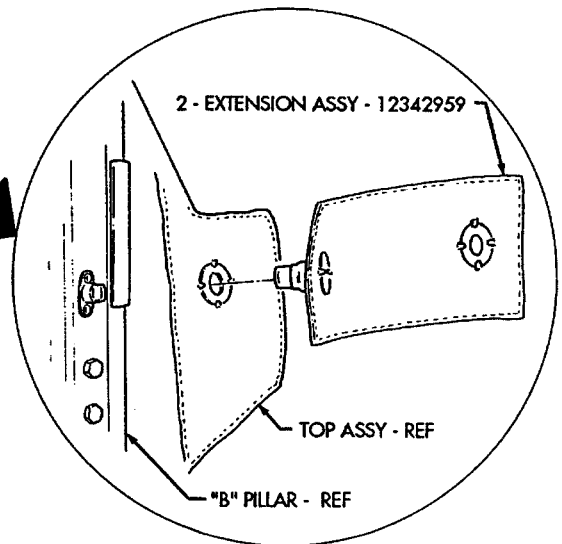

(LEFT SIDE SHOWN, RIGHT SIDE OPPOSITE)

FIGURE 33A

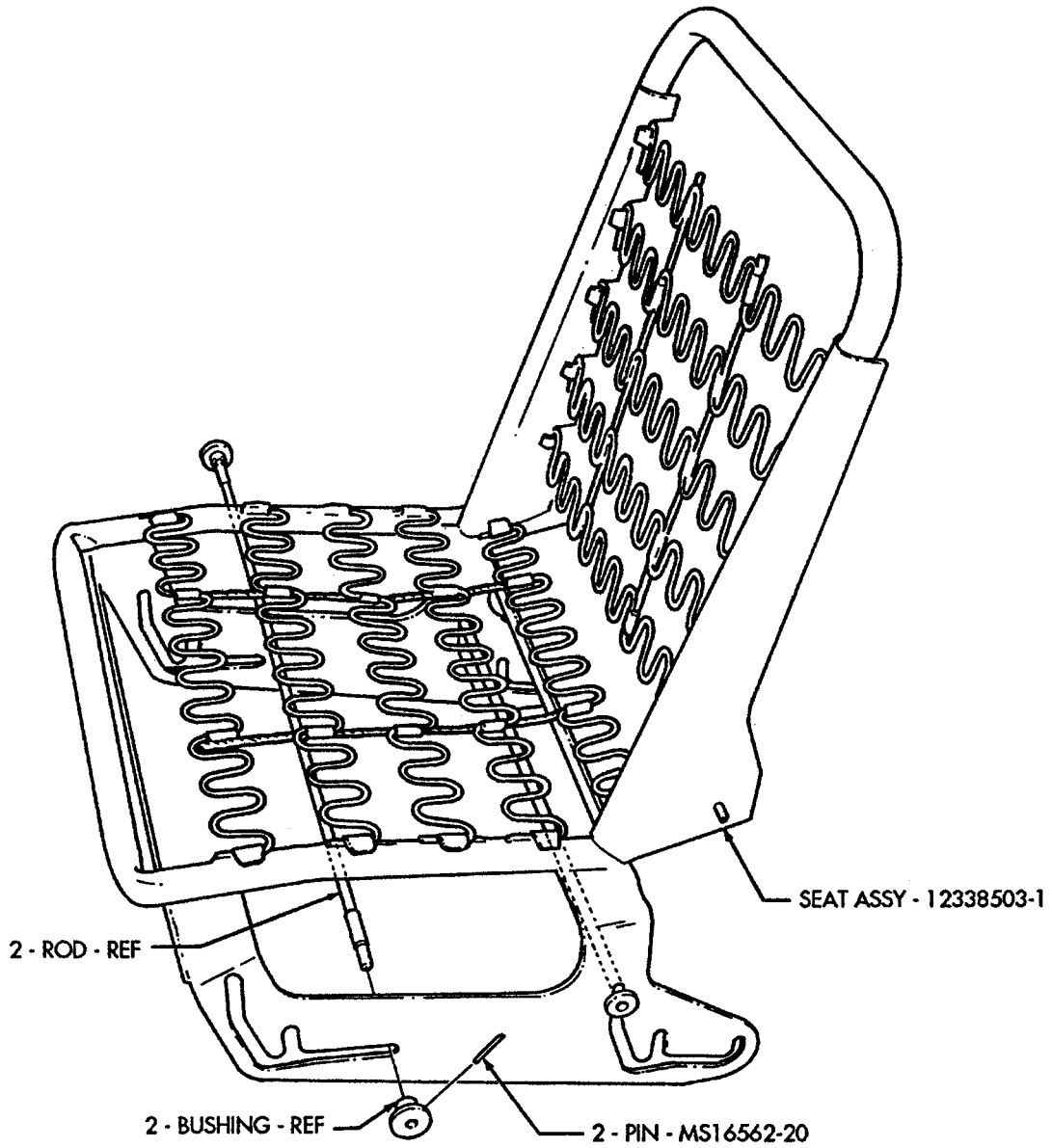
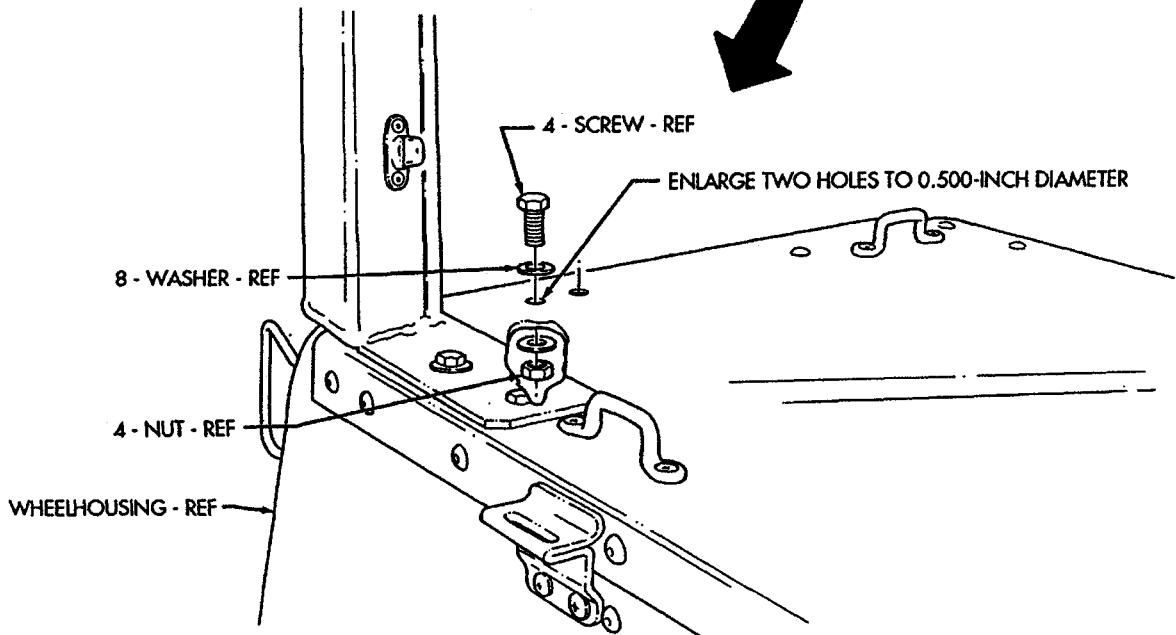
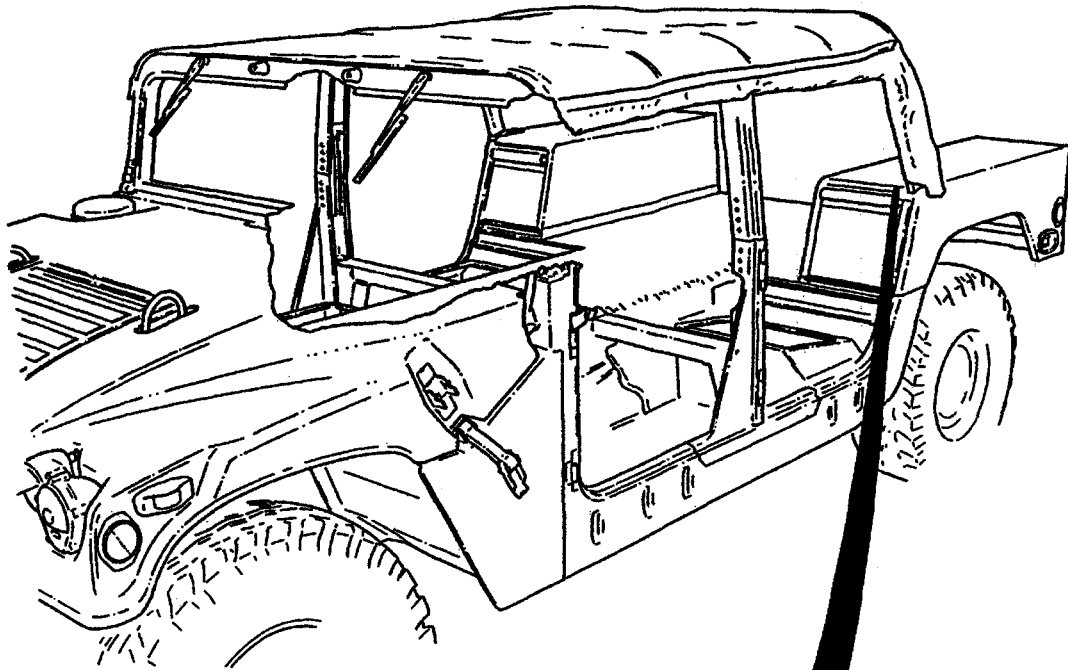

FIGURE 34



(LEFT SIDE SHOWN, RIGHT SIDE OPPOSITE)

FIGURE 35

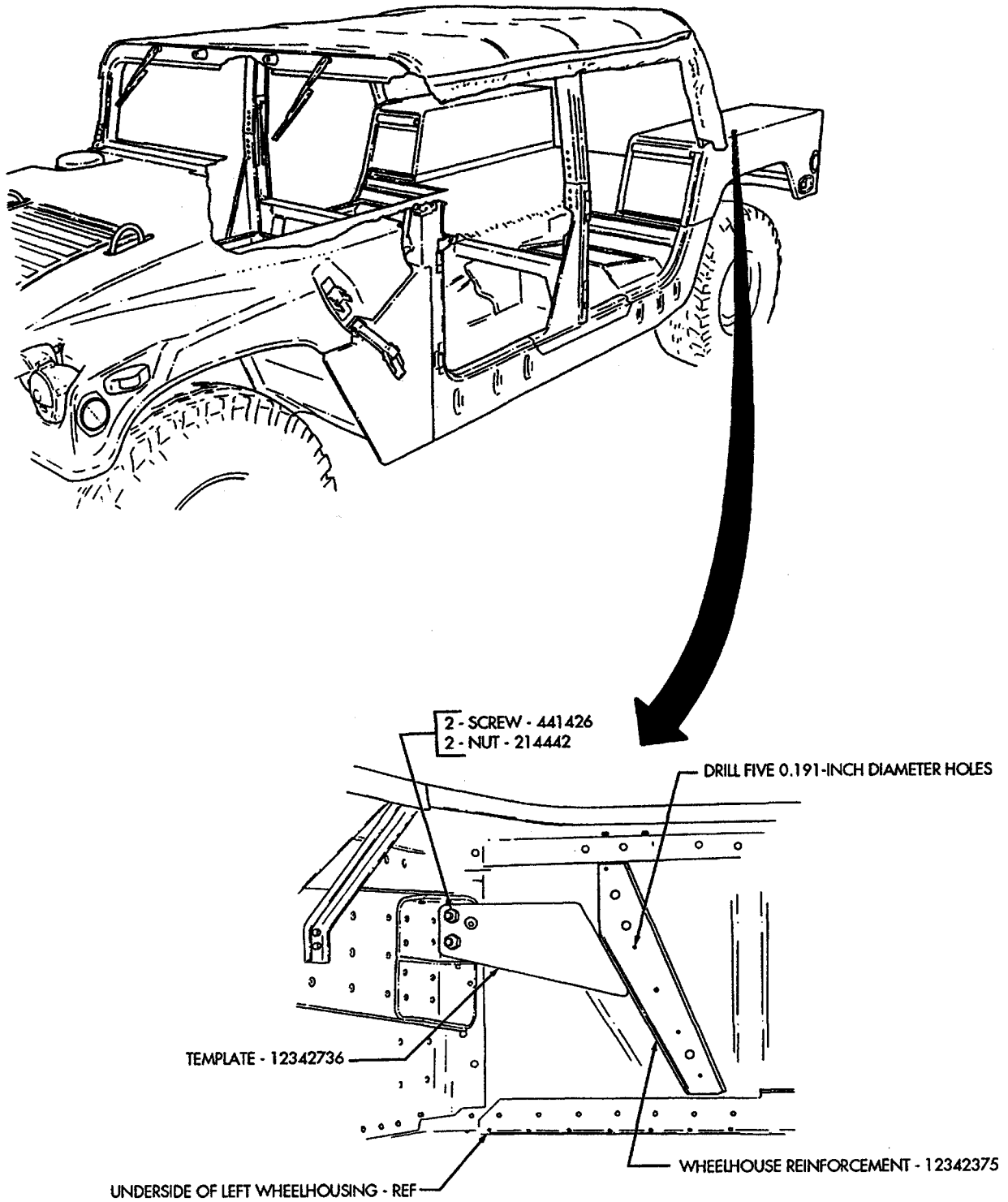

FIGURE 36

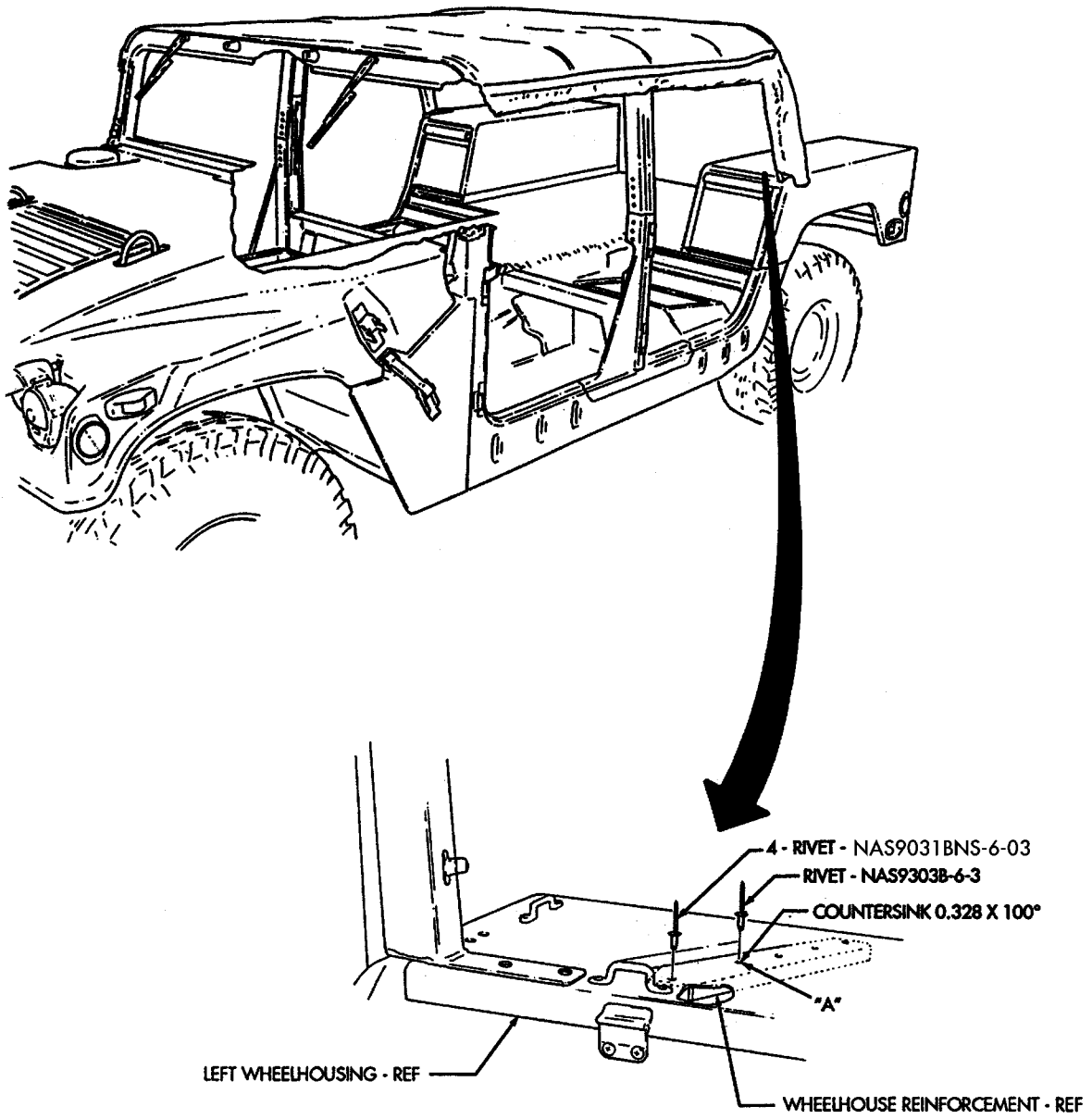
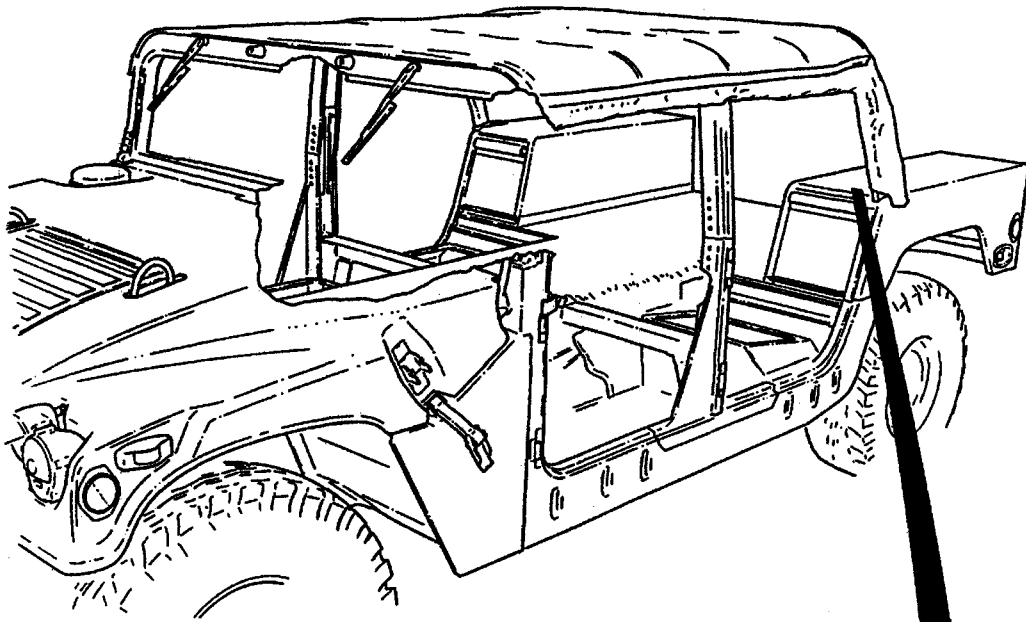
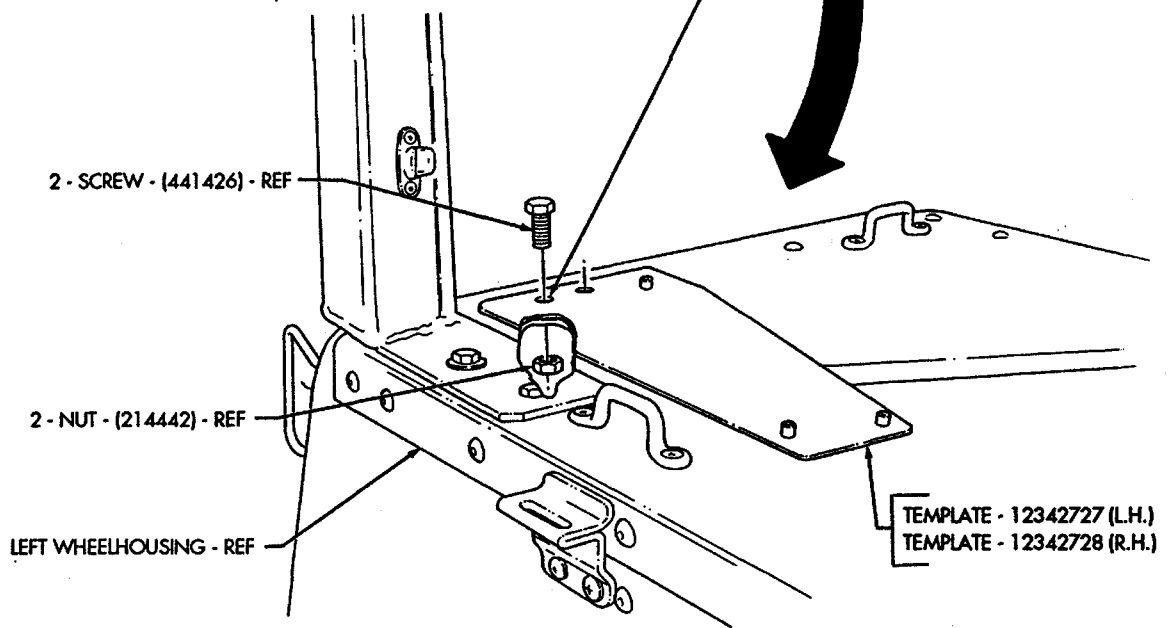

FIGURE 37



DRILL THREE 0.125-INCH DIAMETER HOLES, ENLARGE TO 0.500-INCH DIAMETER



(LEFT SIDE SHOWN, RIGHT SIDE OPPOSITE)

FIGURE 38

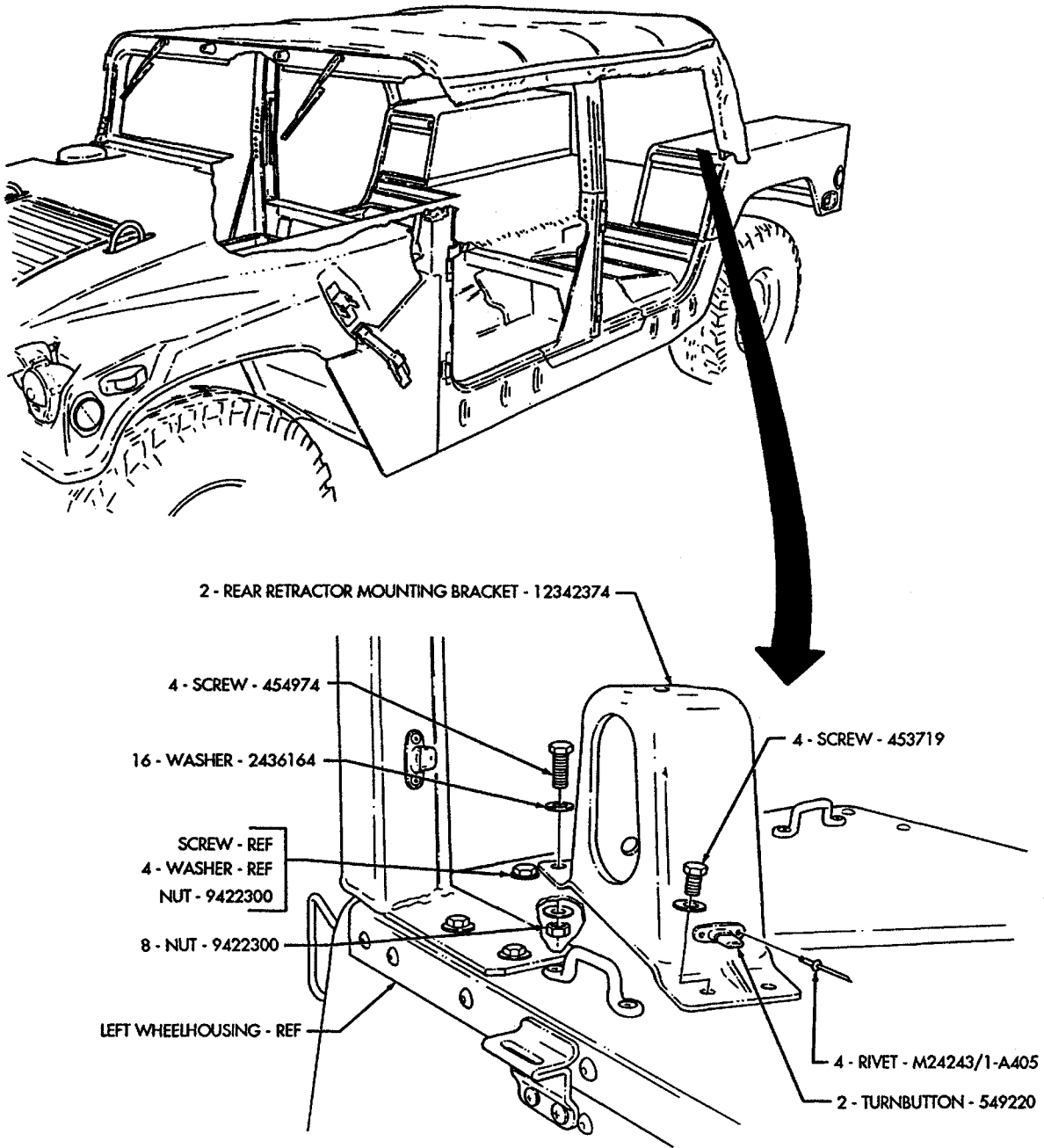

(LEFT SIDE SHOWN, RIGHT SIDE OPPOSITE)

FIGURE 39

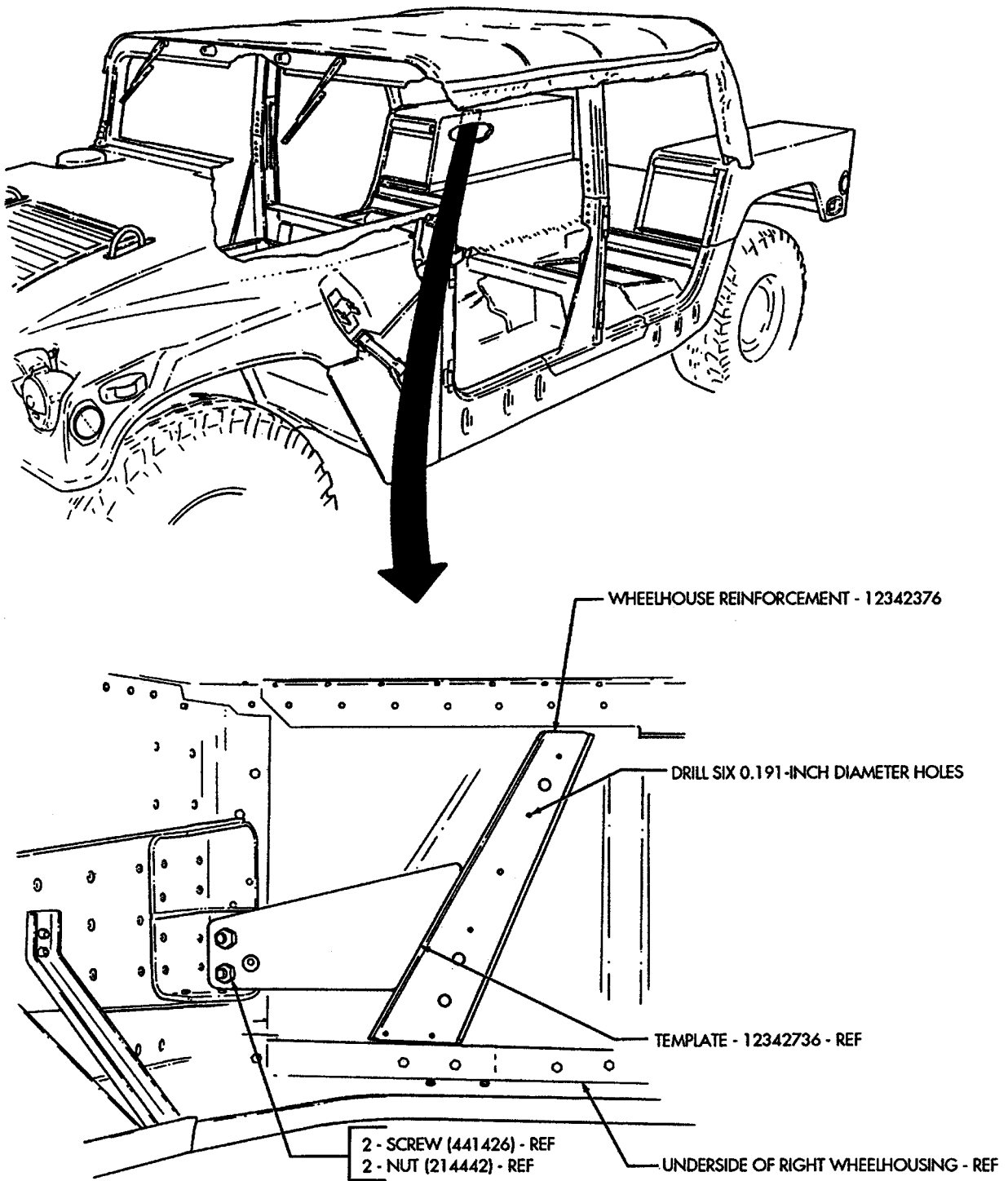

FIGURE 40

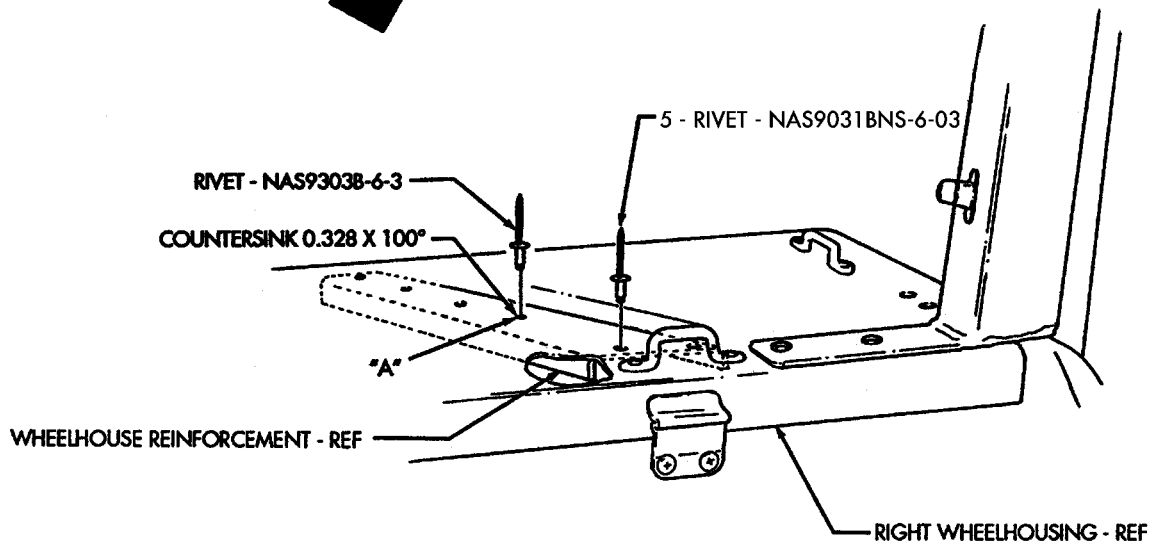
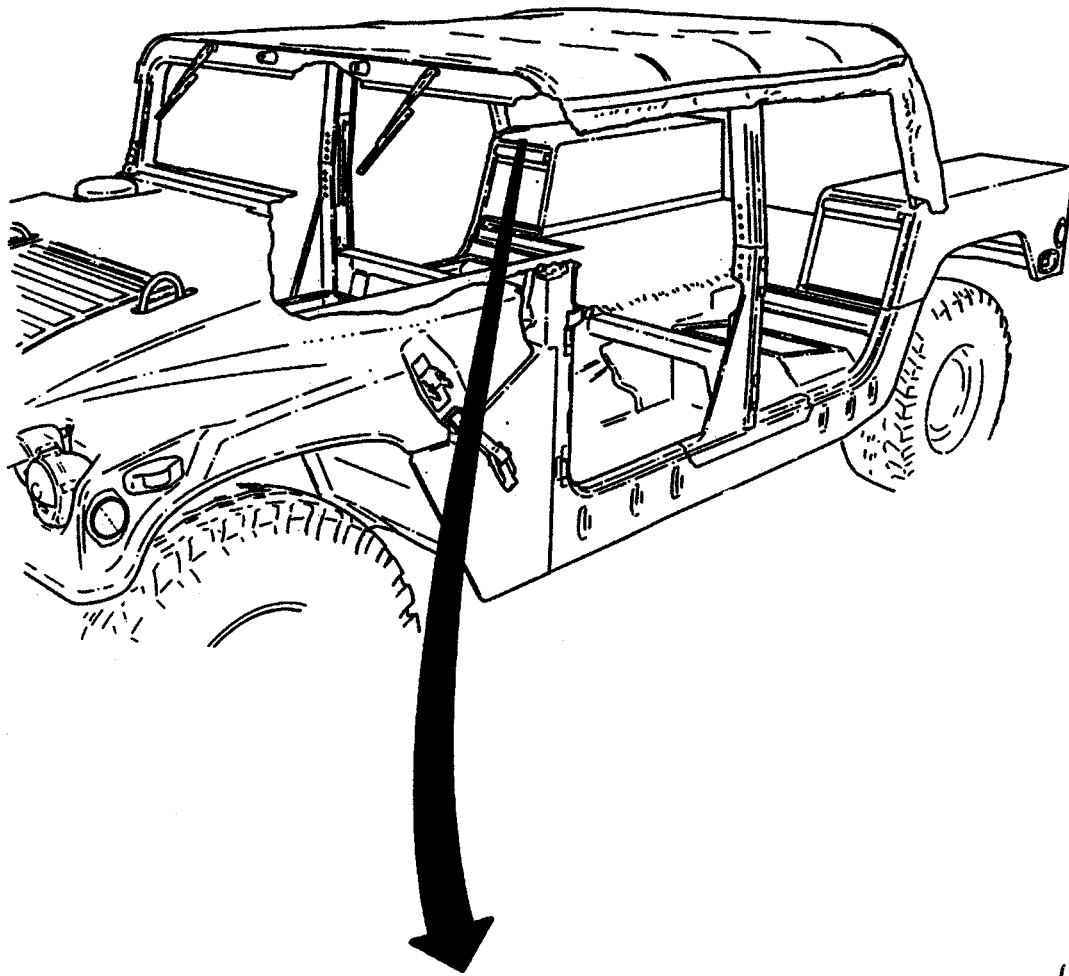
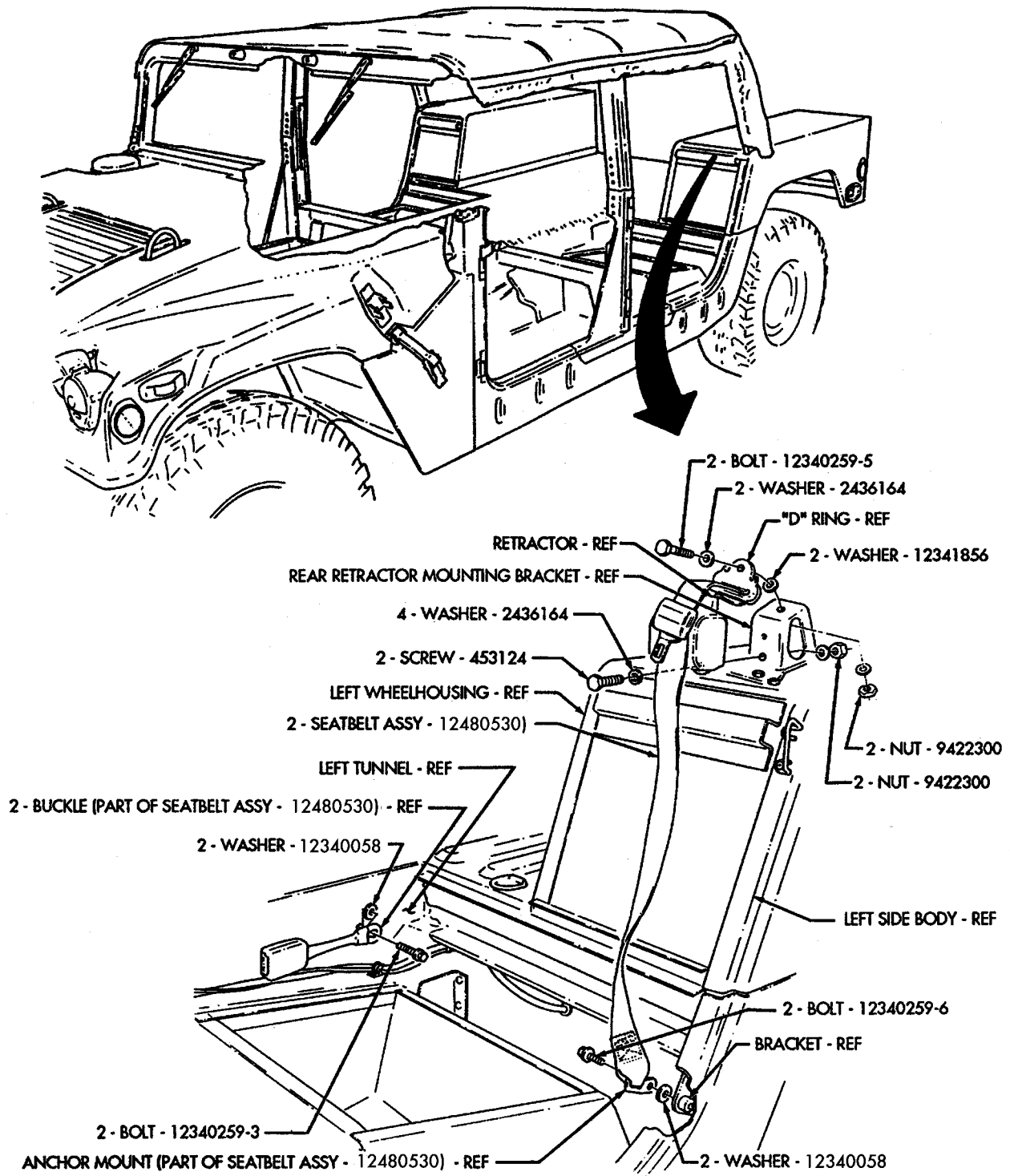
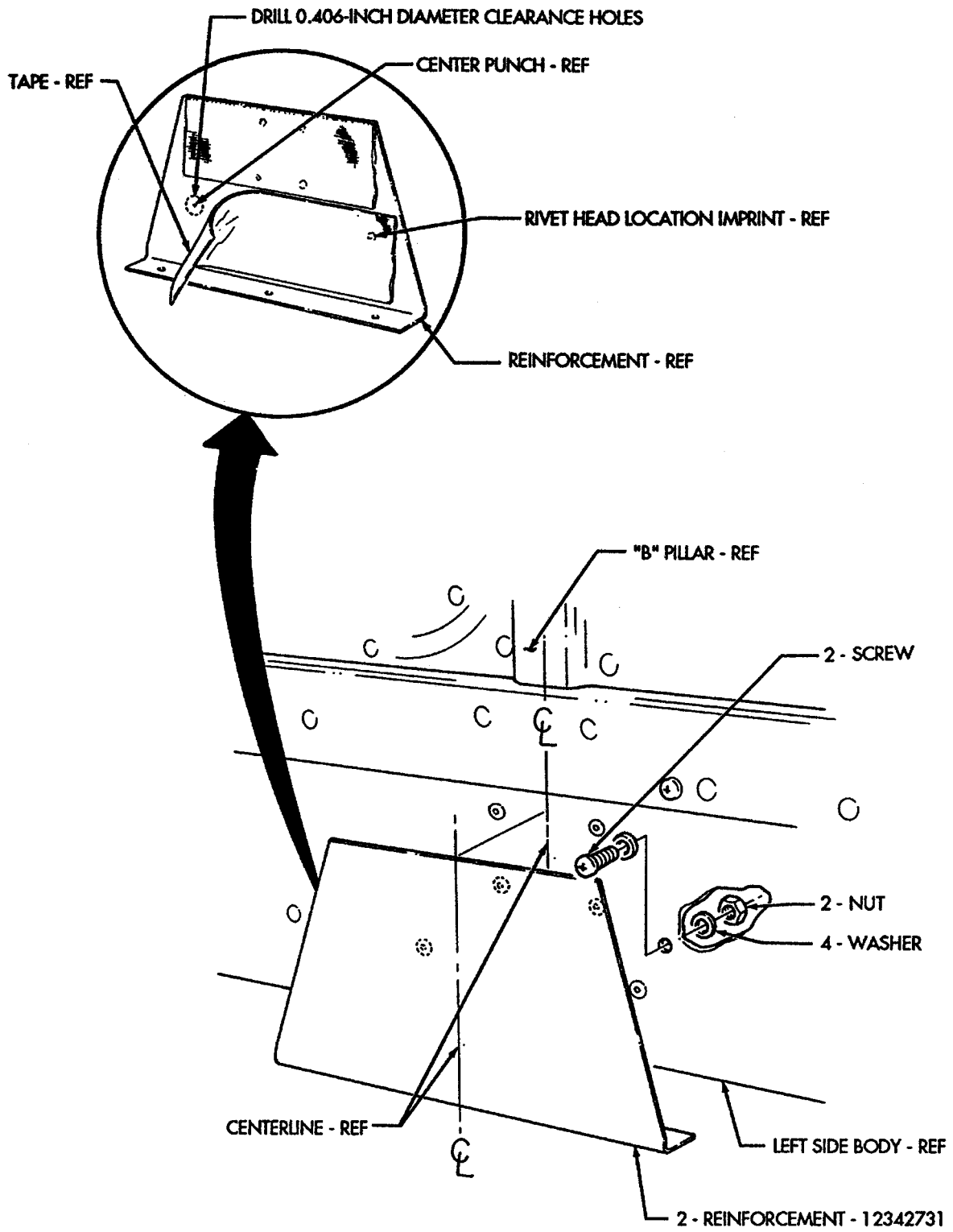

FIGURE 41



(LEFT SIDE SHOWN, RIGHT SIDE OPPOSITE)

FIGURE 42



(LEFT SIDE SHOWN, RIGHT SIDE OPPOSITE)
FIGURE 43

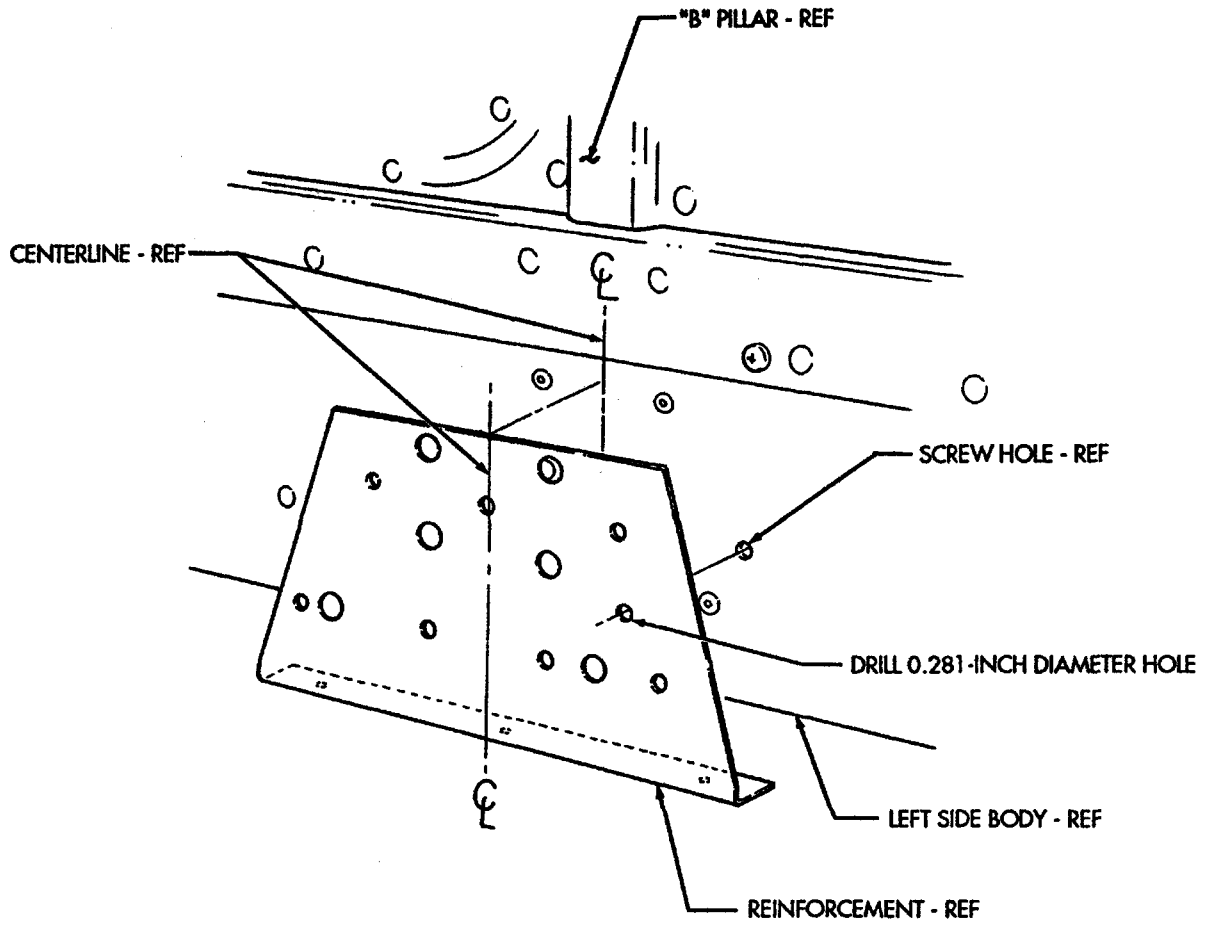

(LEFT SIDE SHOWN, RIGHT SIDE OPPOSITE)

FIGURE 44

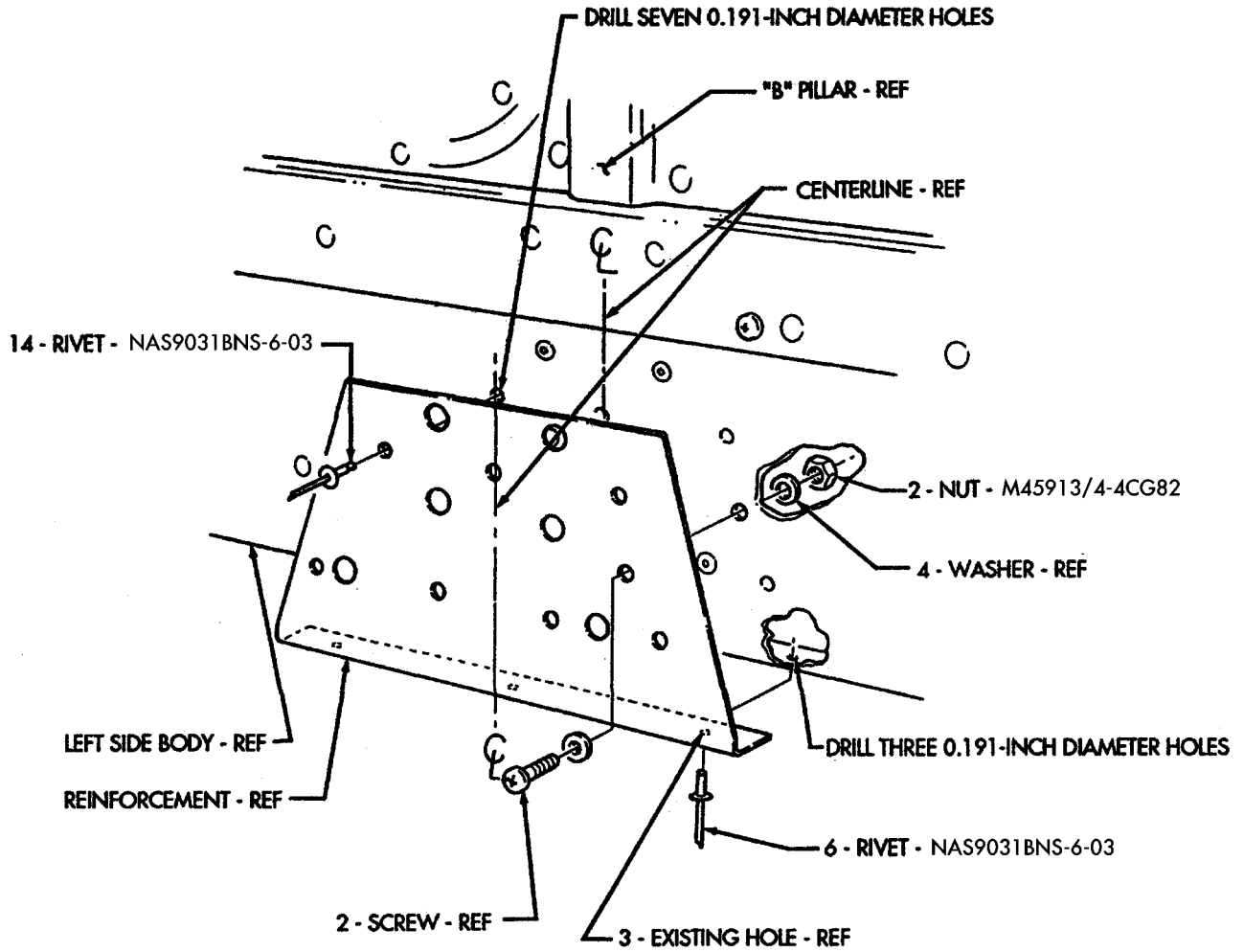

(LEFT SIDE SHOWN, RIGHT SIDE OPPOSITE)

FIGURE 45

ALL DIMENSIONS ARE IN INCHES

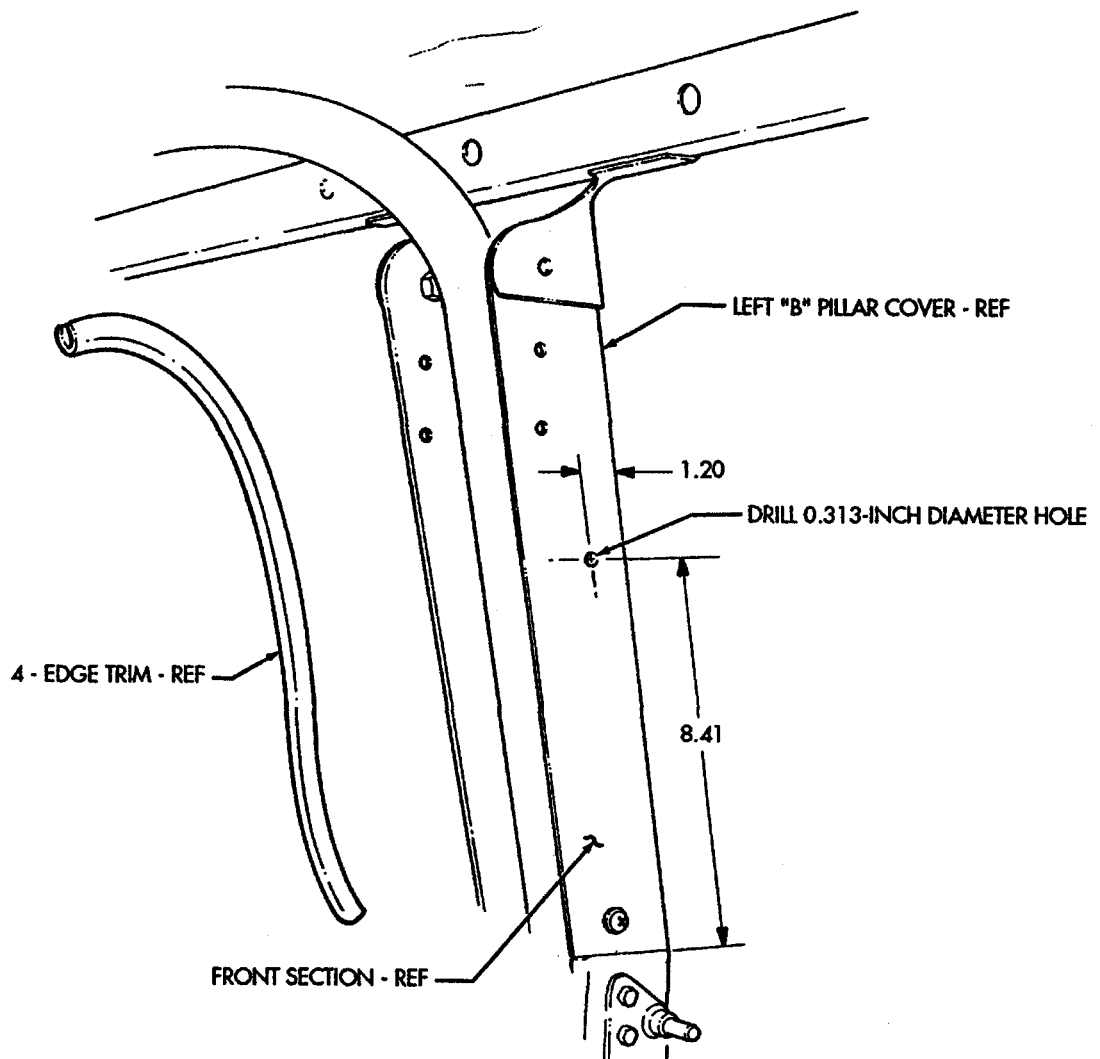

TO FRONT OF VEHICLE

(LEFT SIDE SHOWN, RIGHT SIDE OPPOSITE)

FIGURE 46

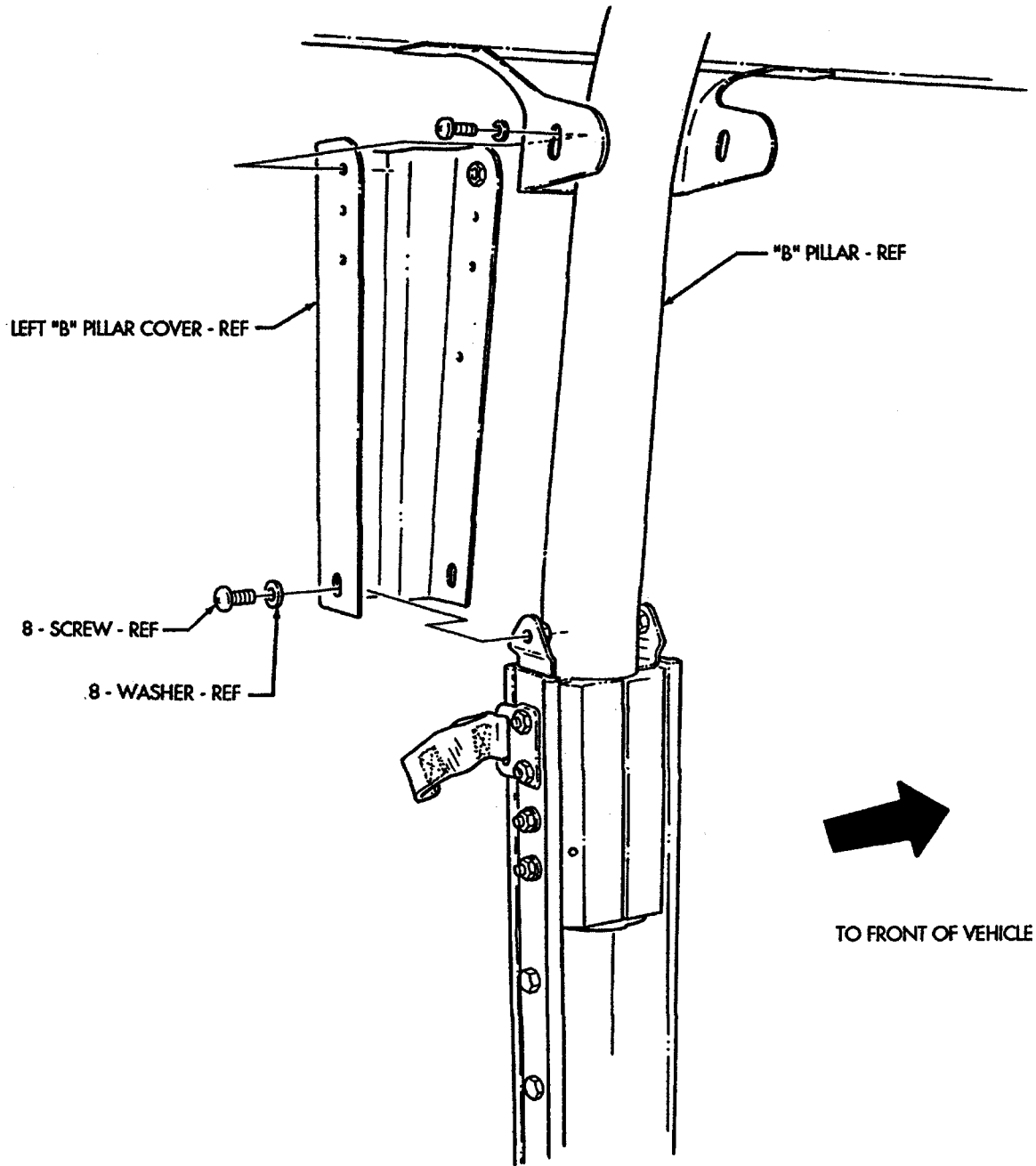

(LEFT SIDE SHOWN, RIGHT SIDE OPPOSITE)

FIGURE 47

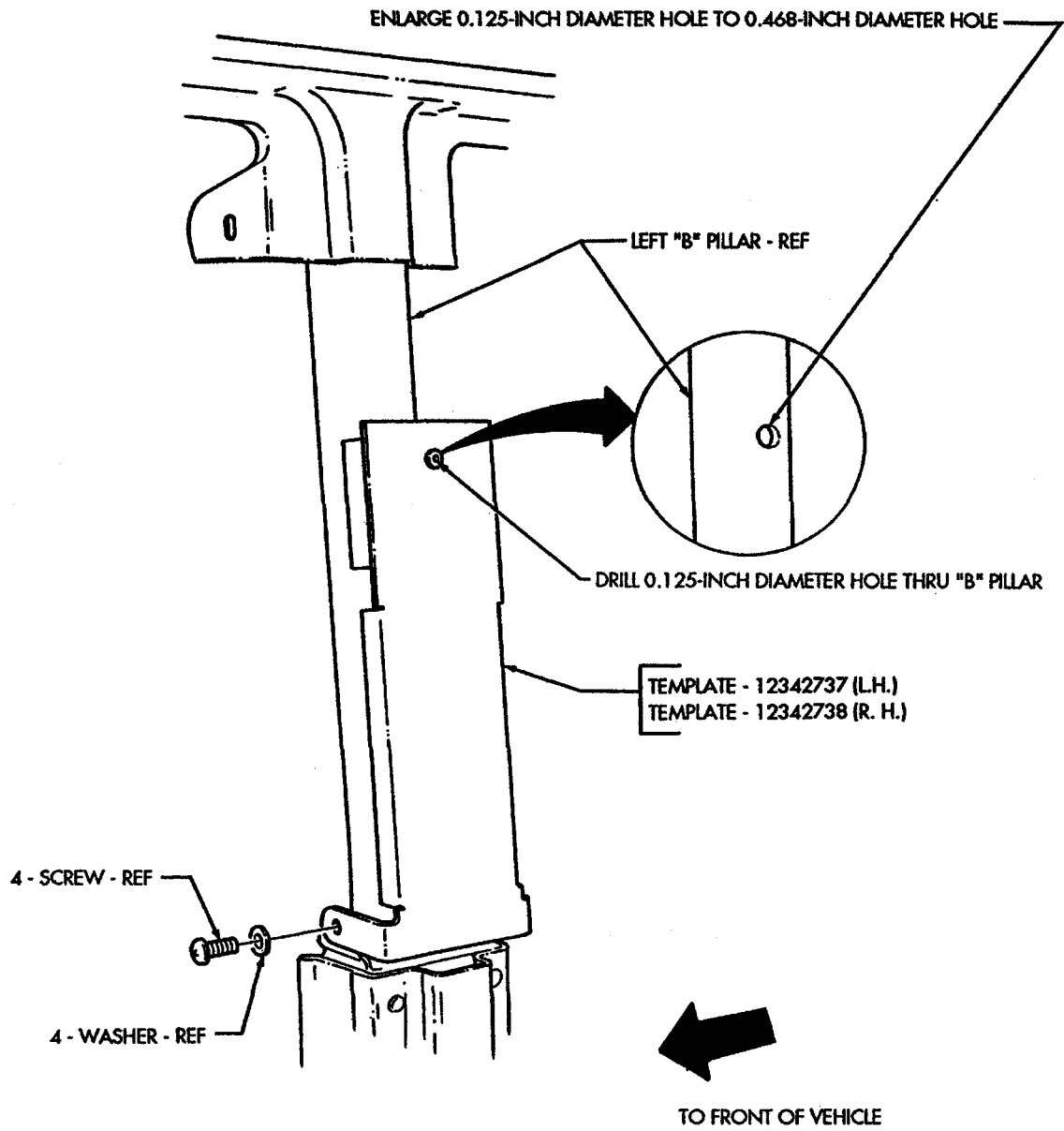

(LEFT SIDE SHOWN, RIGHT SIDE OPPOSITE)

FIGURE 48

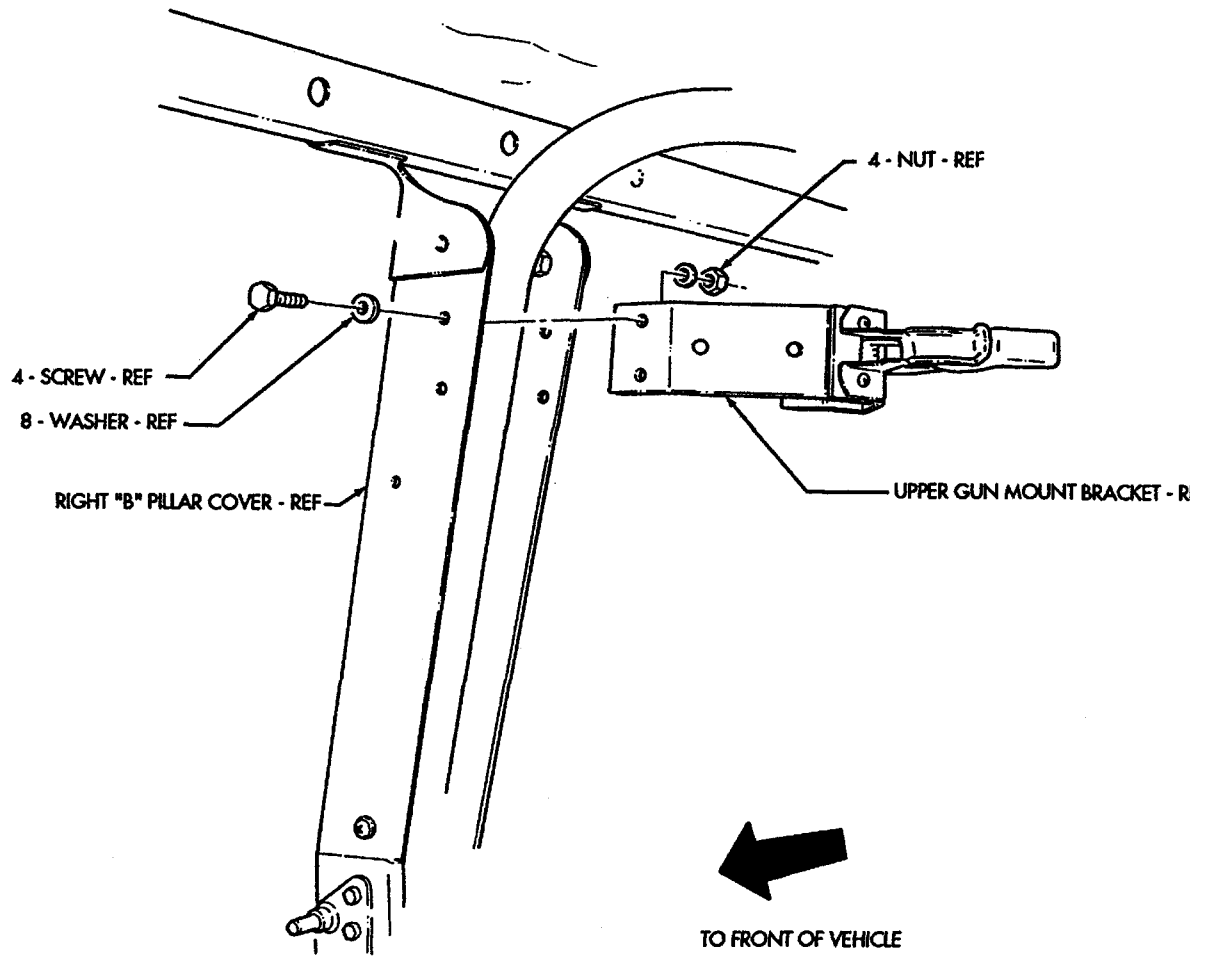
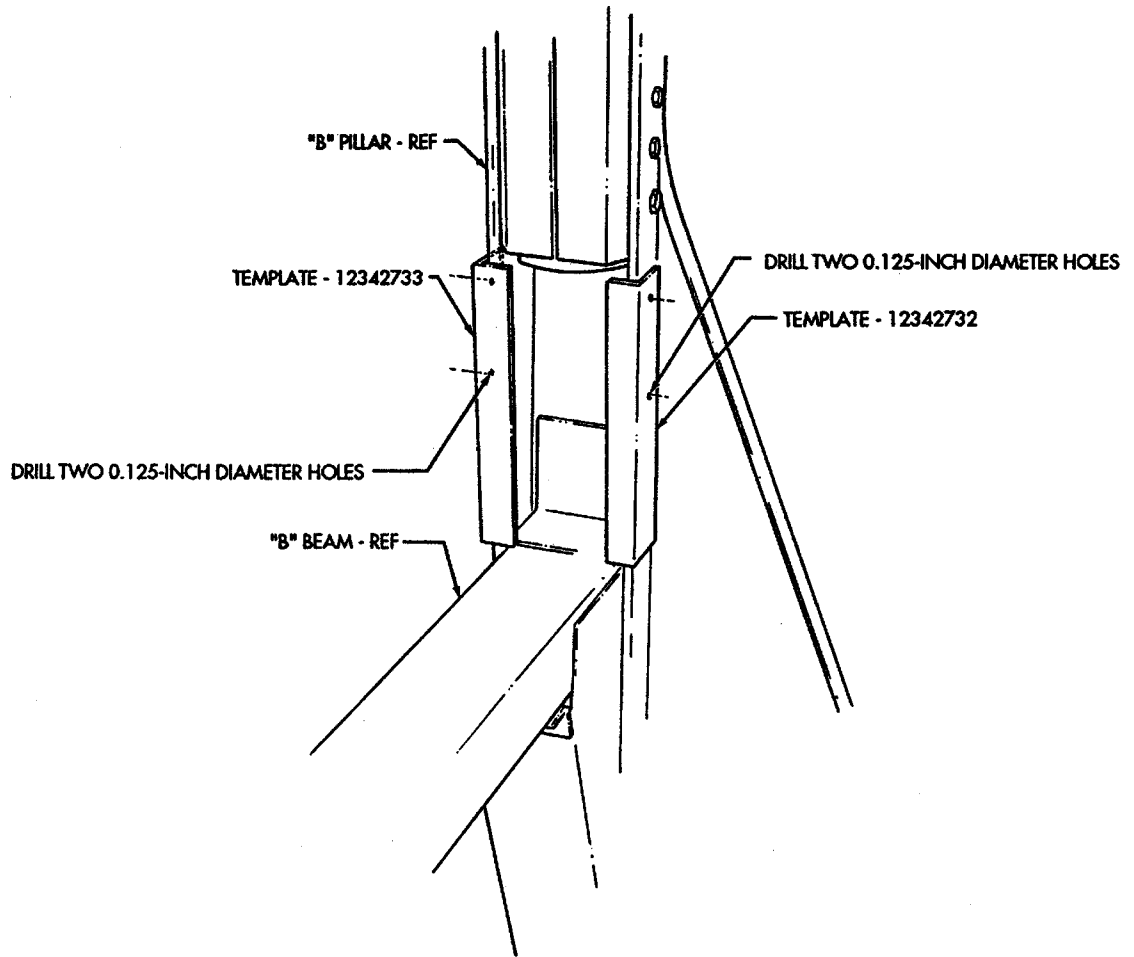
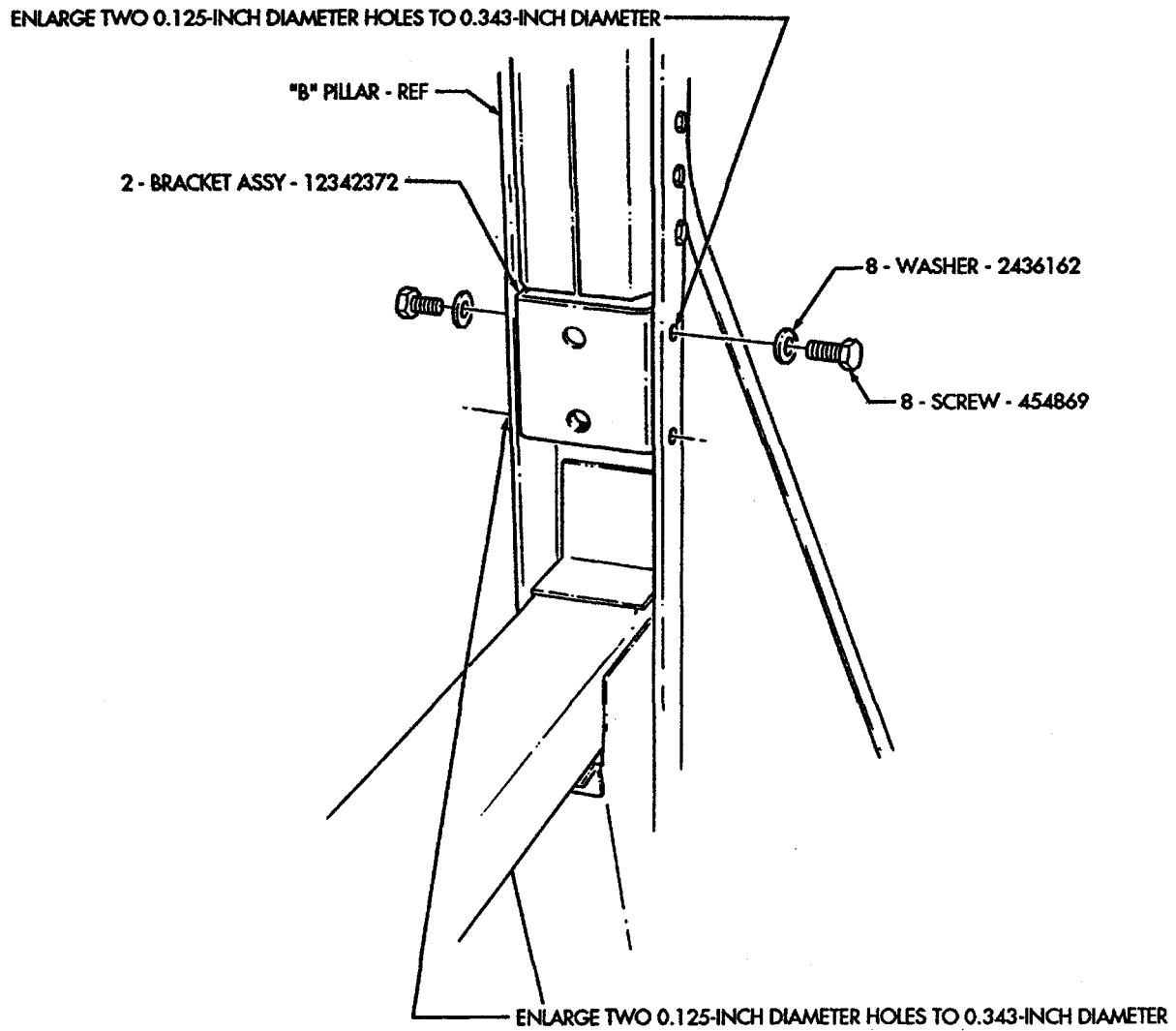

FIGURE 49



(LEFT SIDE SHOWN, RIGHT SIDE OPPOSITE)

FIGURE 50



(LEFT SIDE SHOWN, RIGHT SIDE OPPOSITE)

FIGURE 51

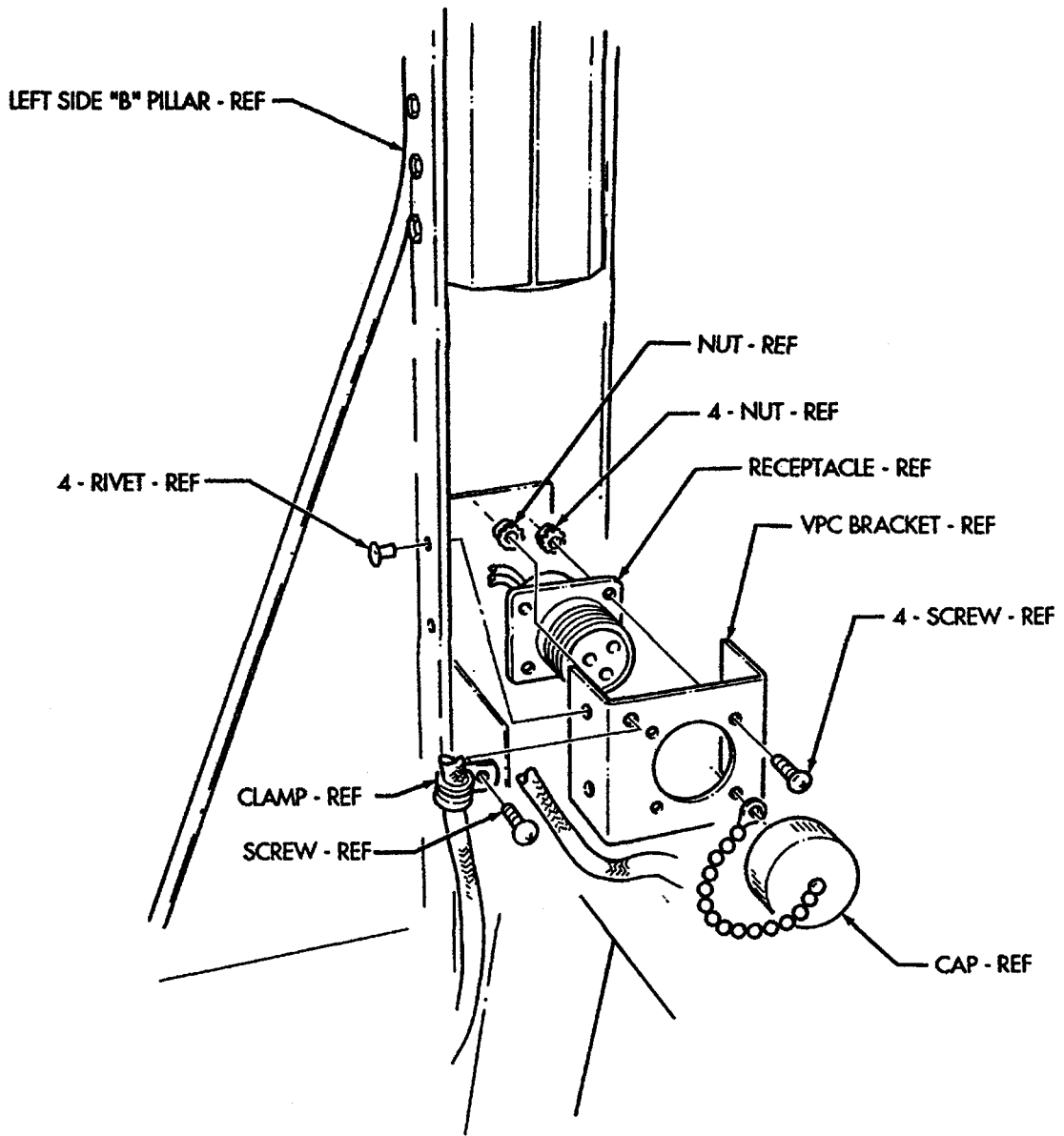

FIGURE 52

ALL DIMENSIONS ARE IN INCHES

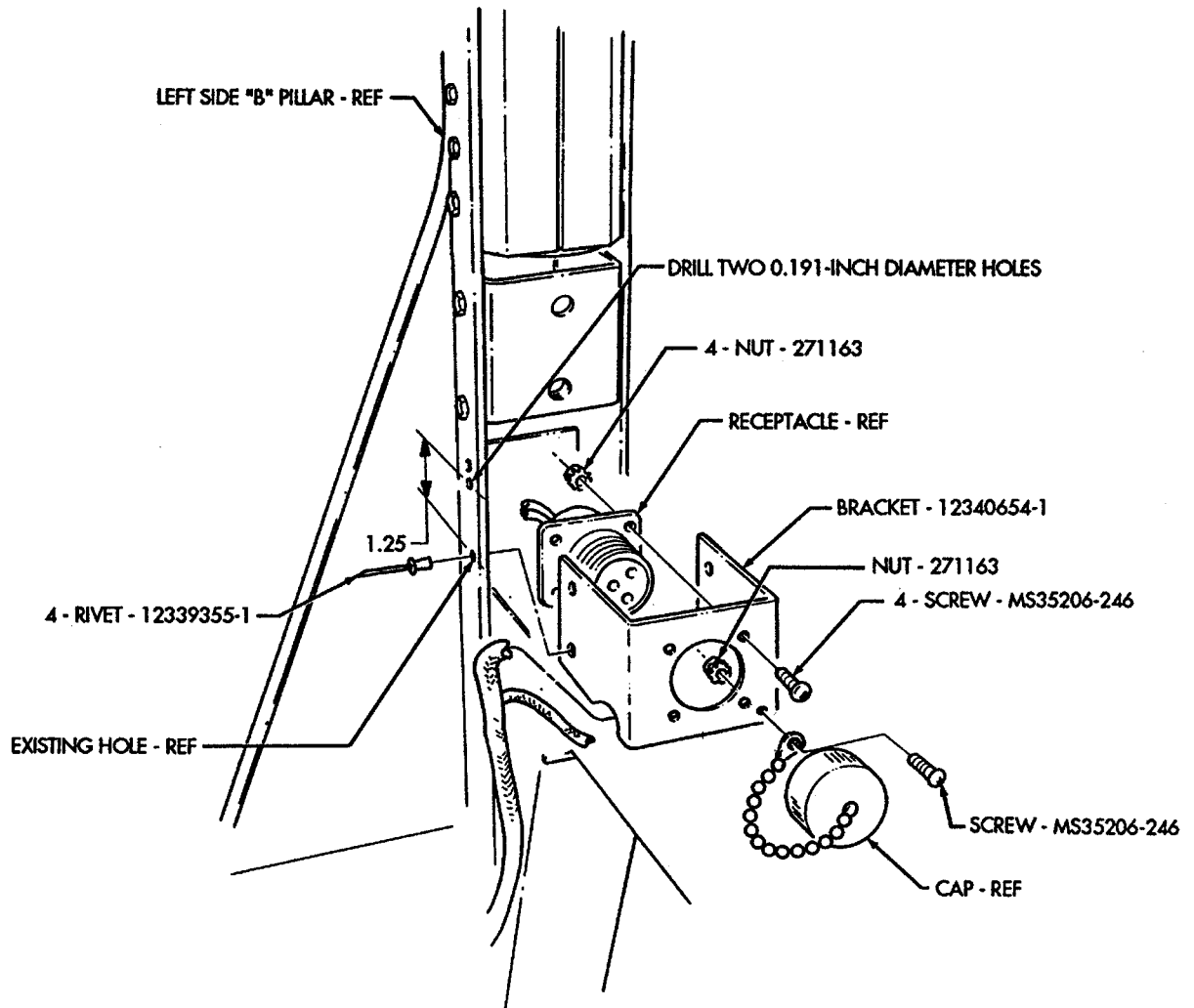

FIGURE 53

ALL DIMENSIONS ARE IN INCHES

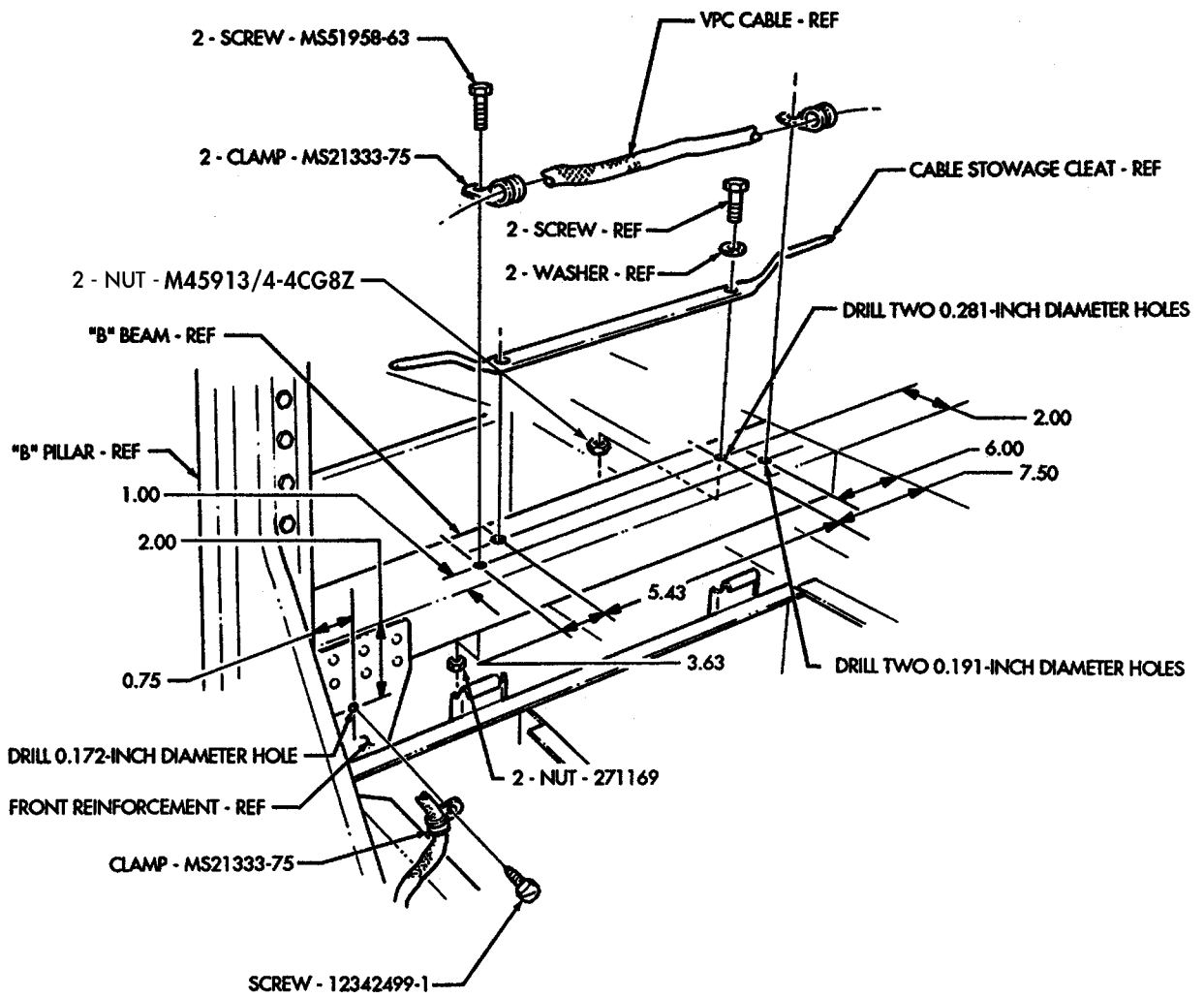

FIGURE 54

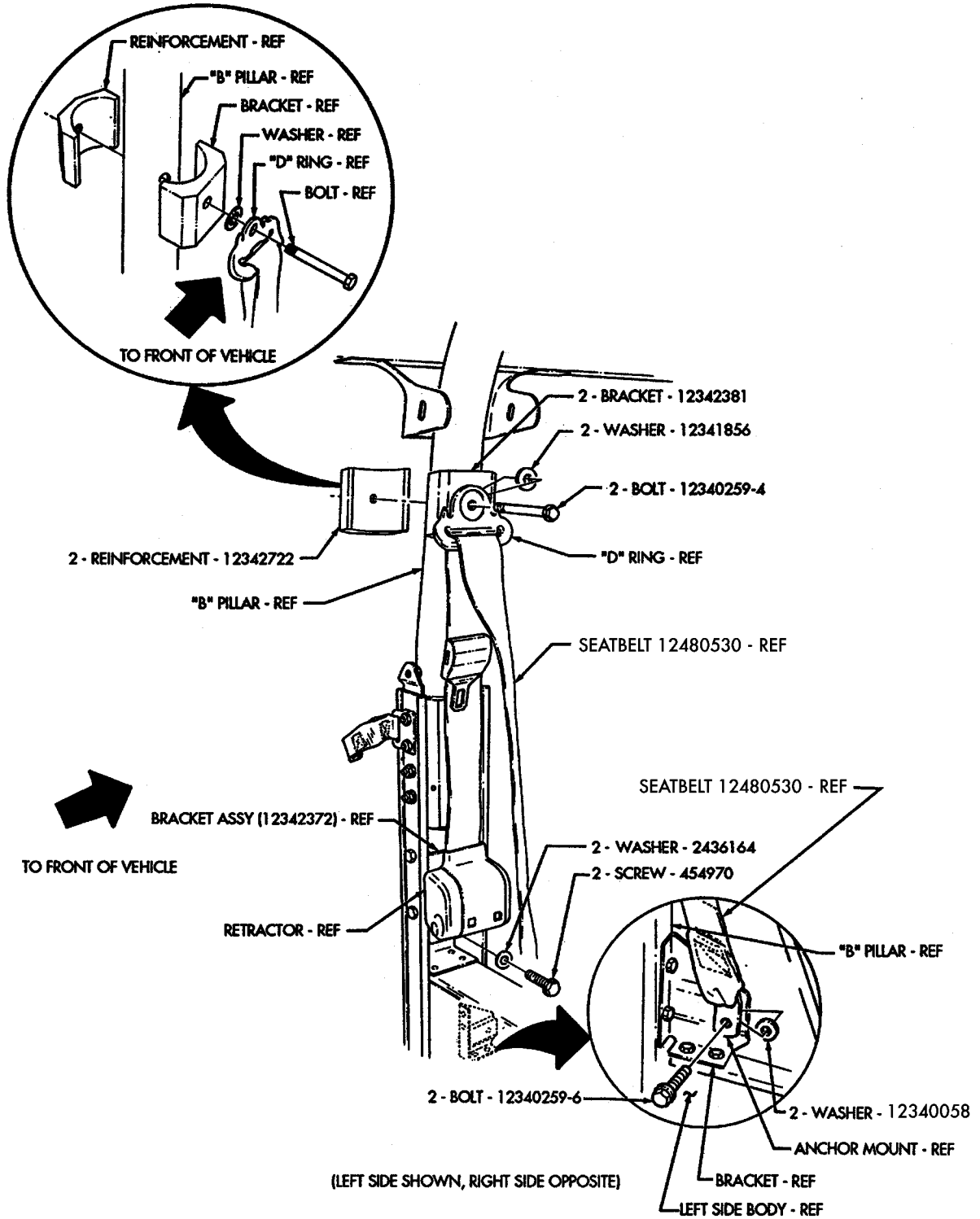
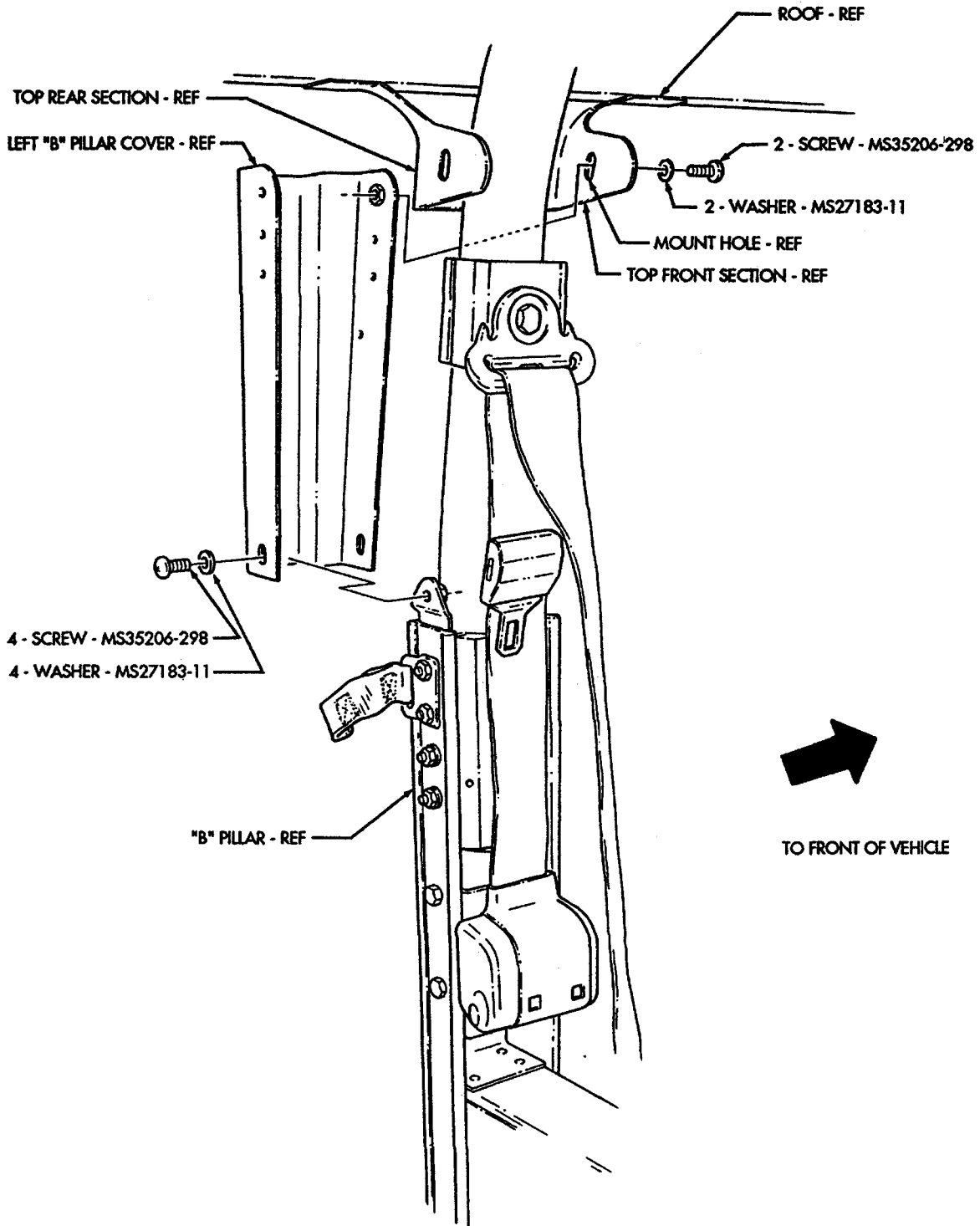
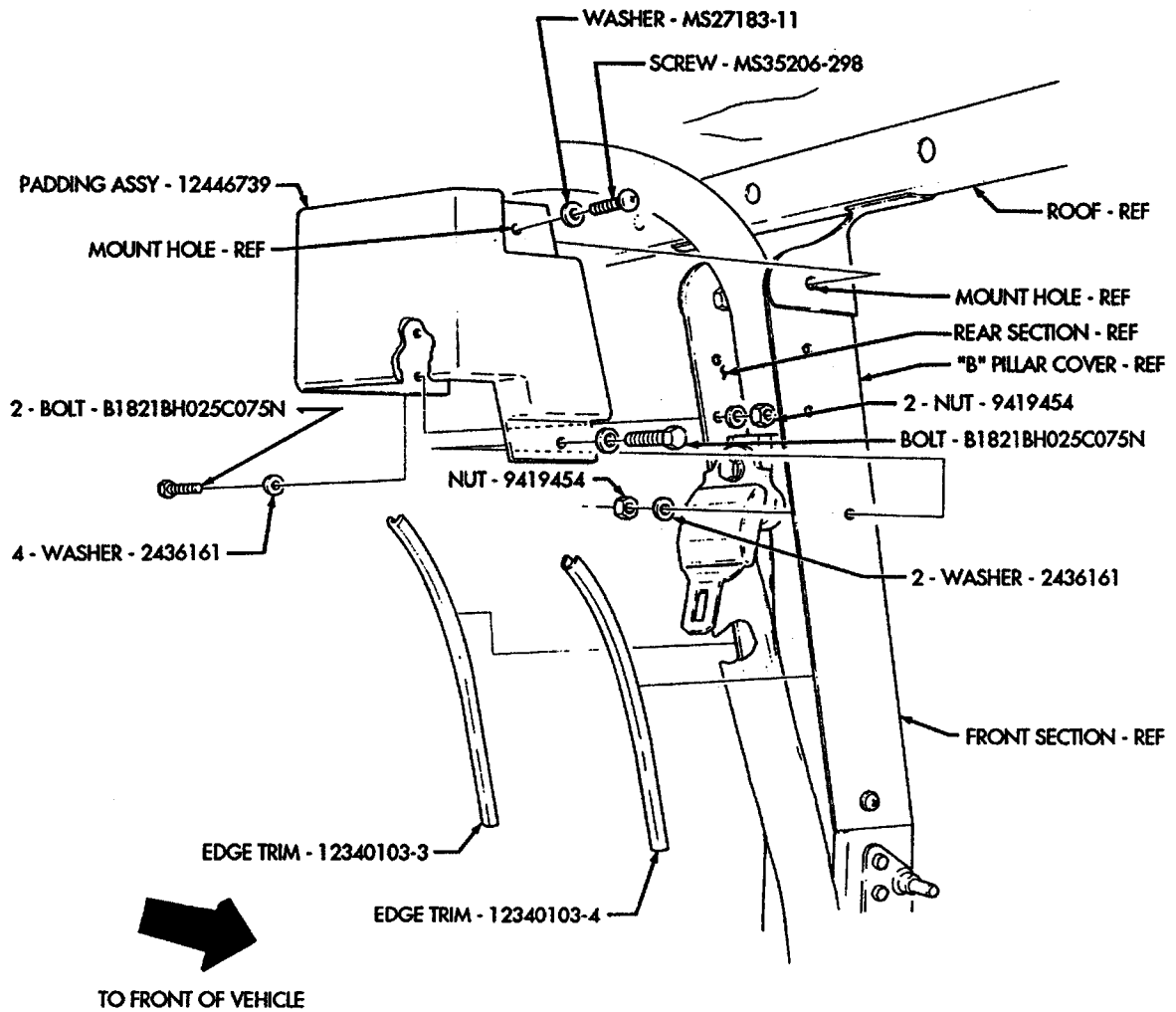

FIGURE 55



(LEFT SIDE SHOWN, RIGHT SIDE OPPOSITE)

FIGURE 56



(LEFT SIDE SHOWN, RIGHT SIDE OPPOSITE)

FIGURE 57

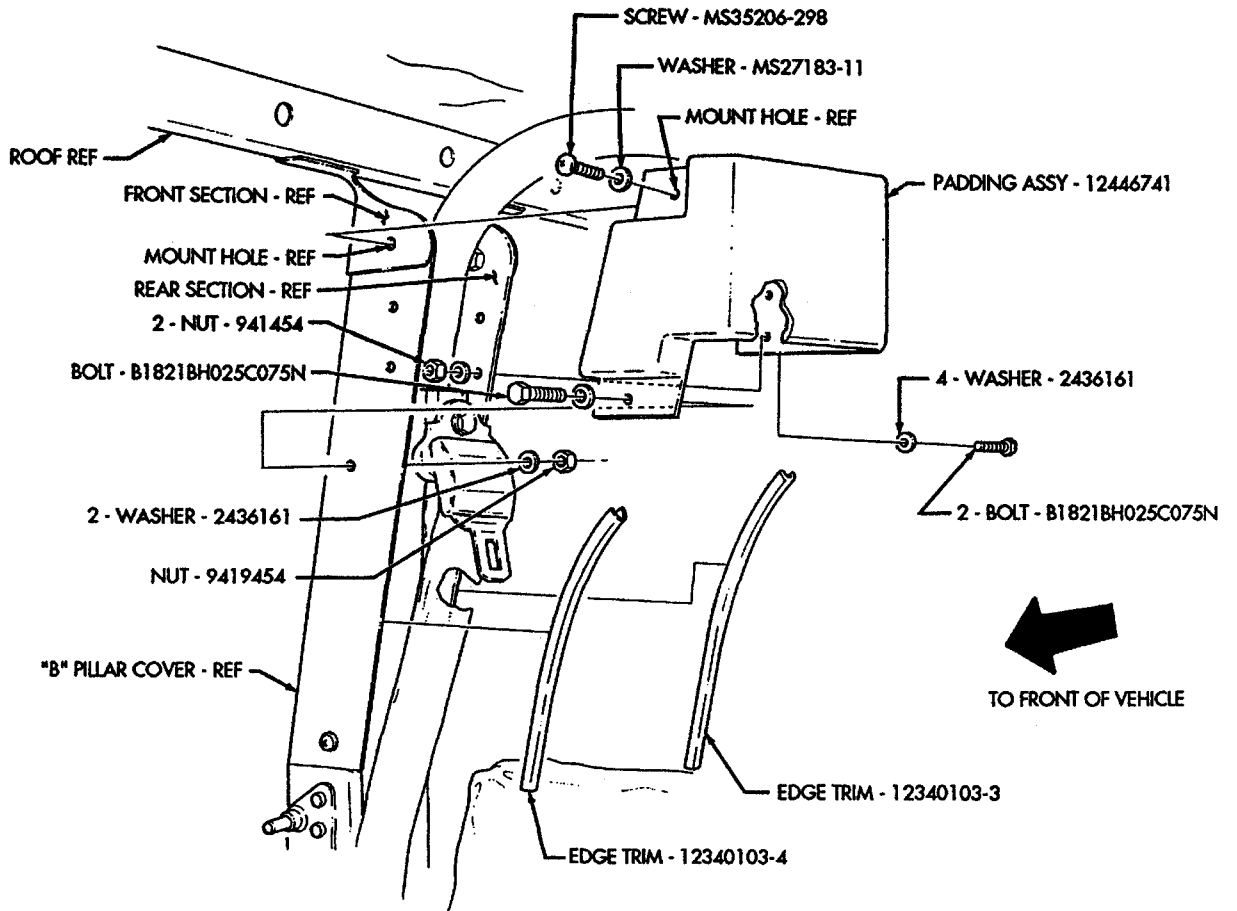

FIGURE 58

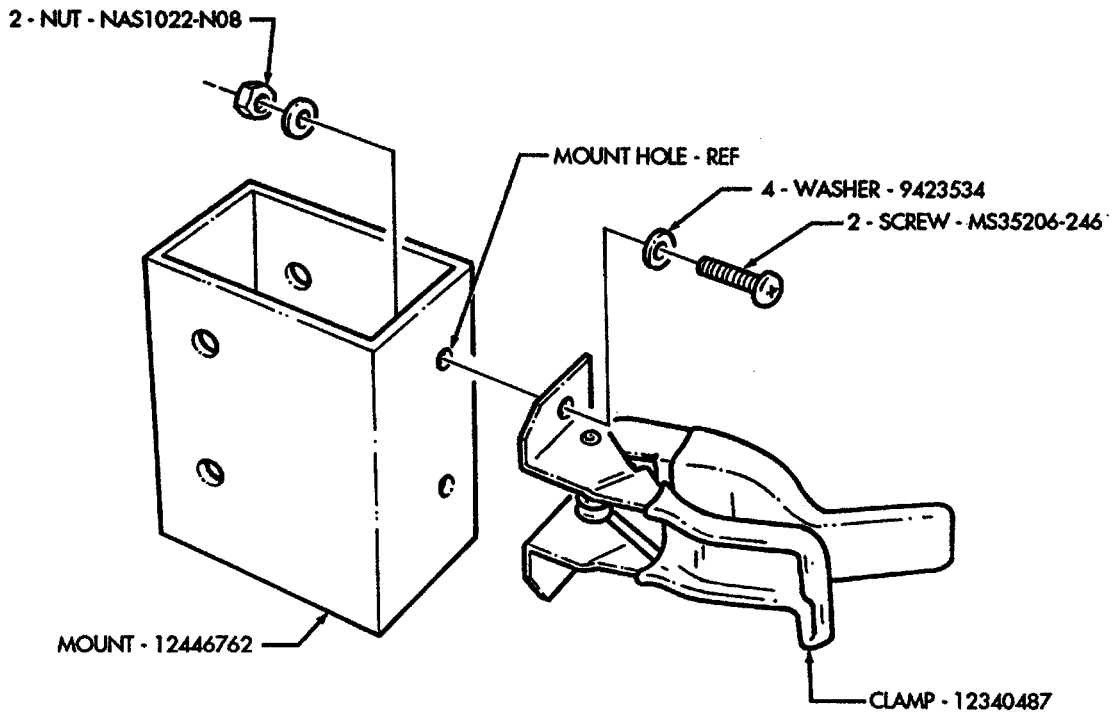

FIGURE 59

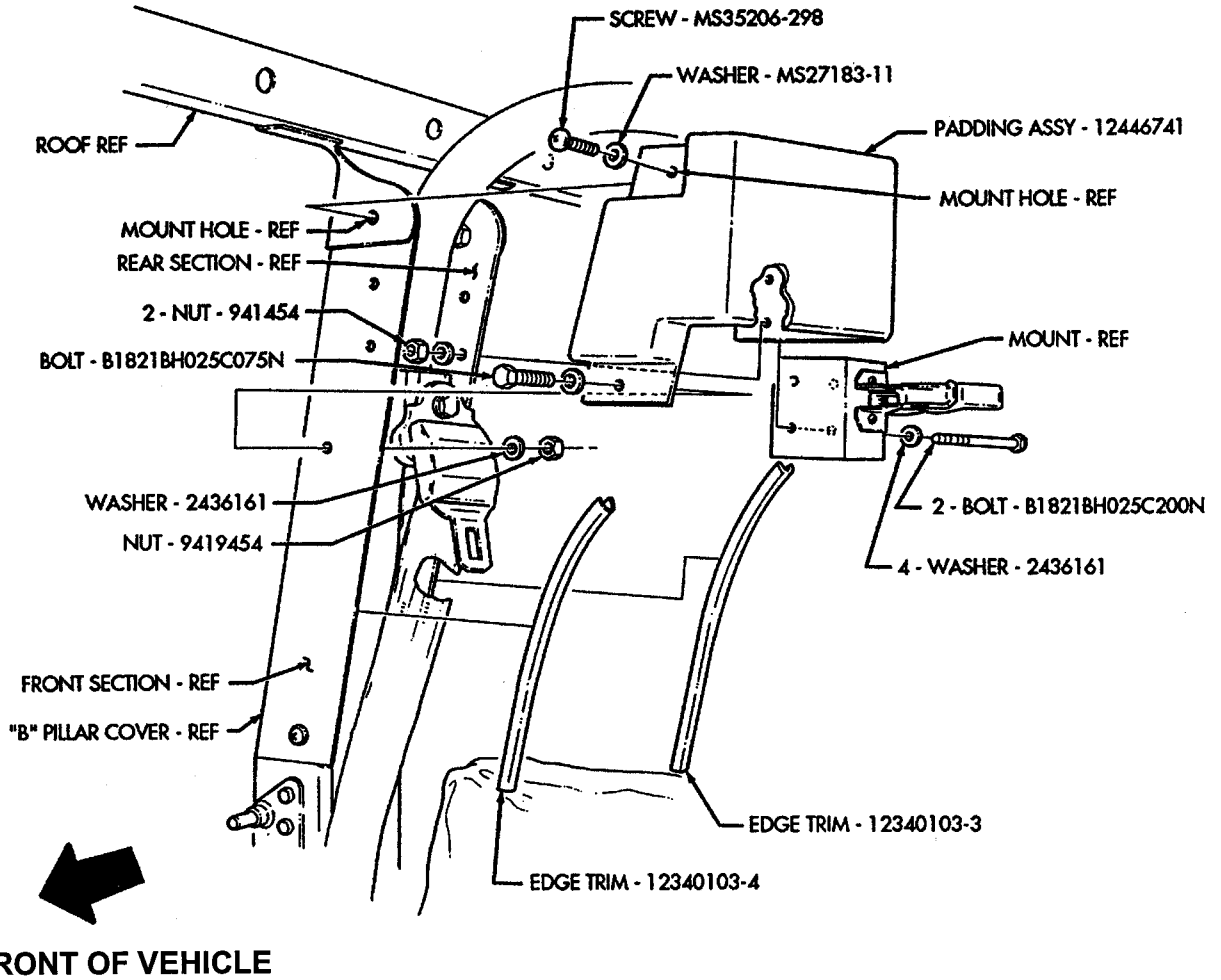
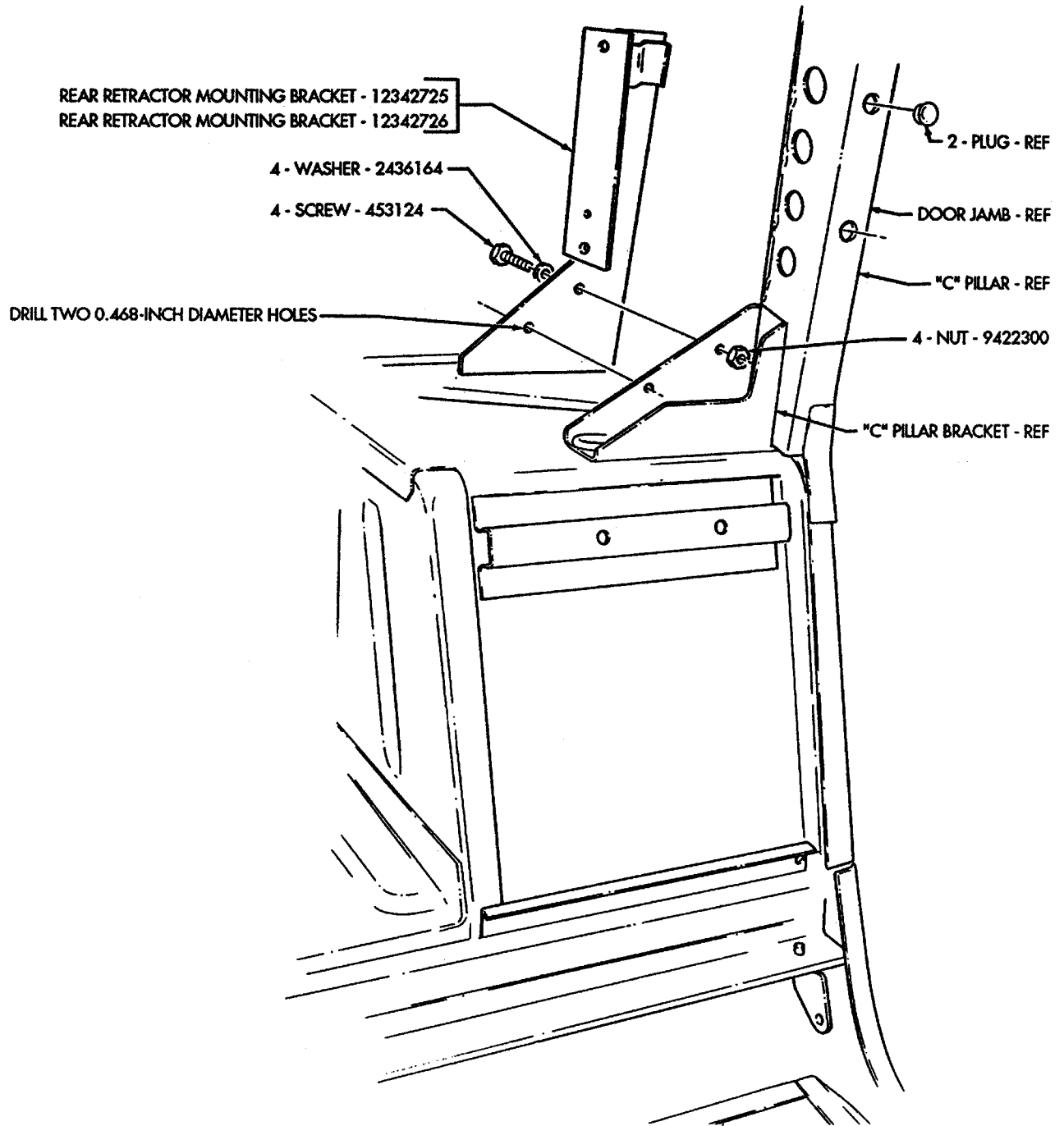
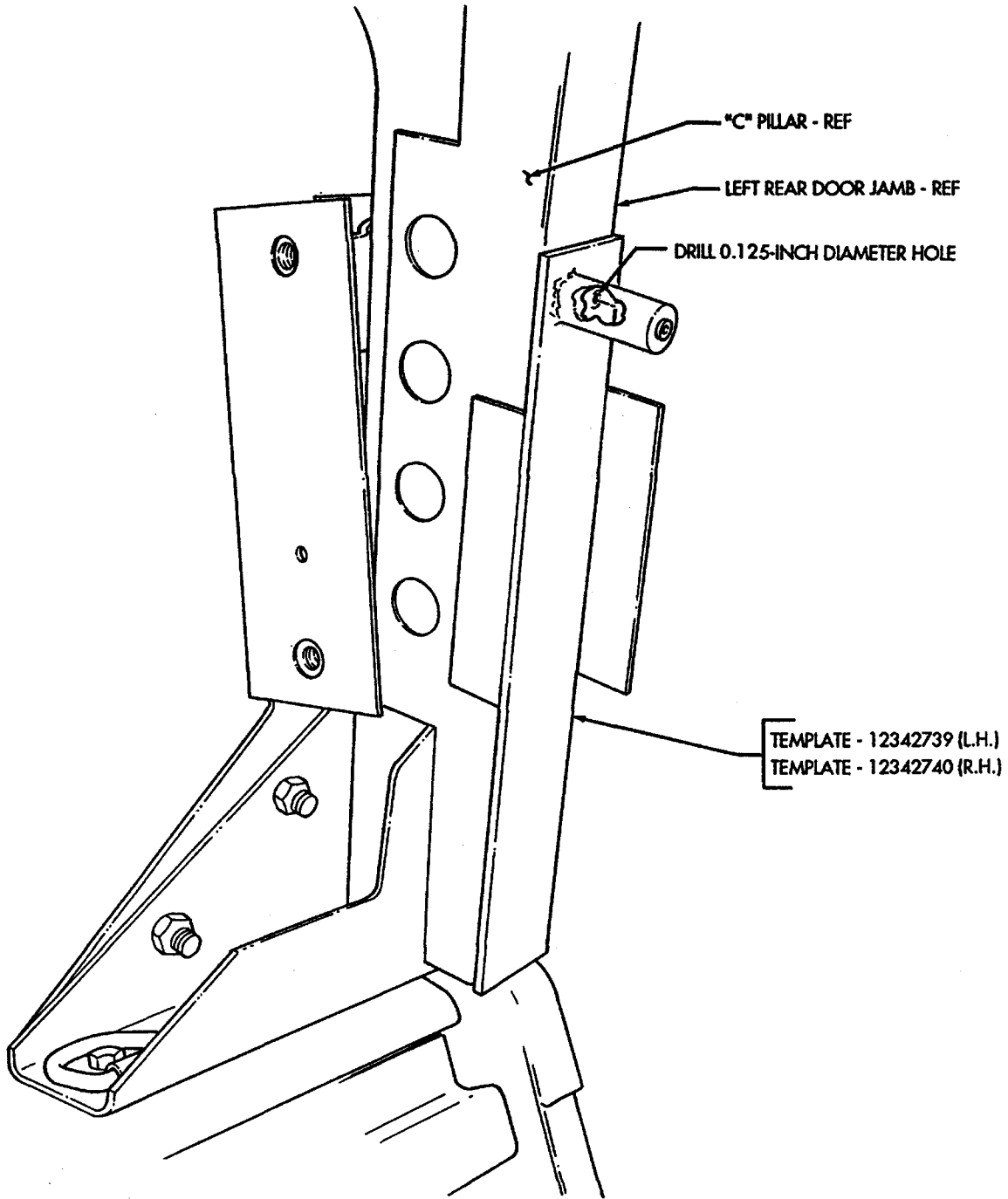

FIGURE 60



(LEFT SIDE SHOWN, RIGHT SIDE OPPOSITE)

FIGURE 61



(LEFT SIDE SHOWN, RIGHT SIDE OPPOSITE)

FIGURE 62

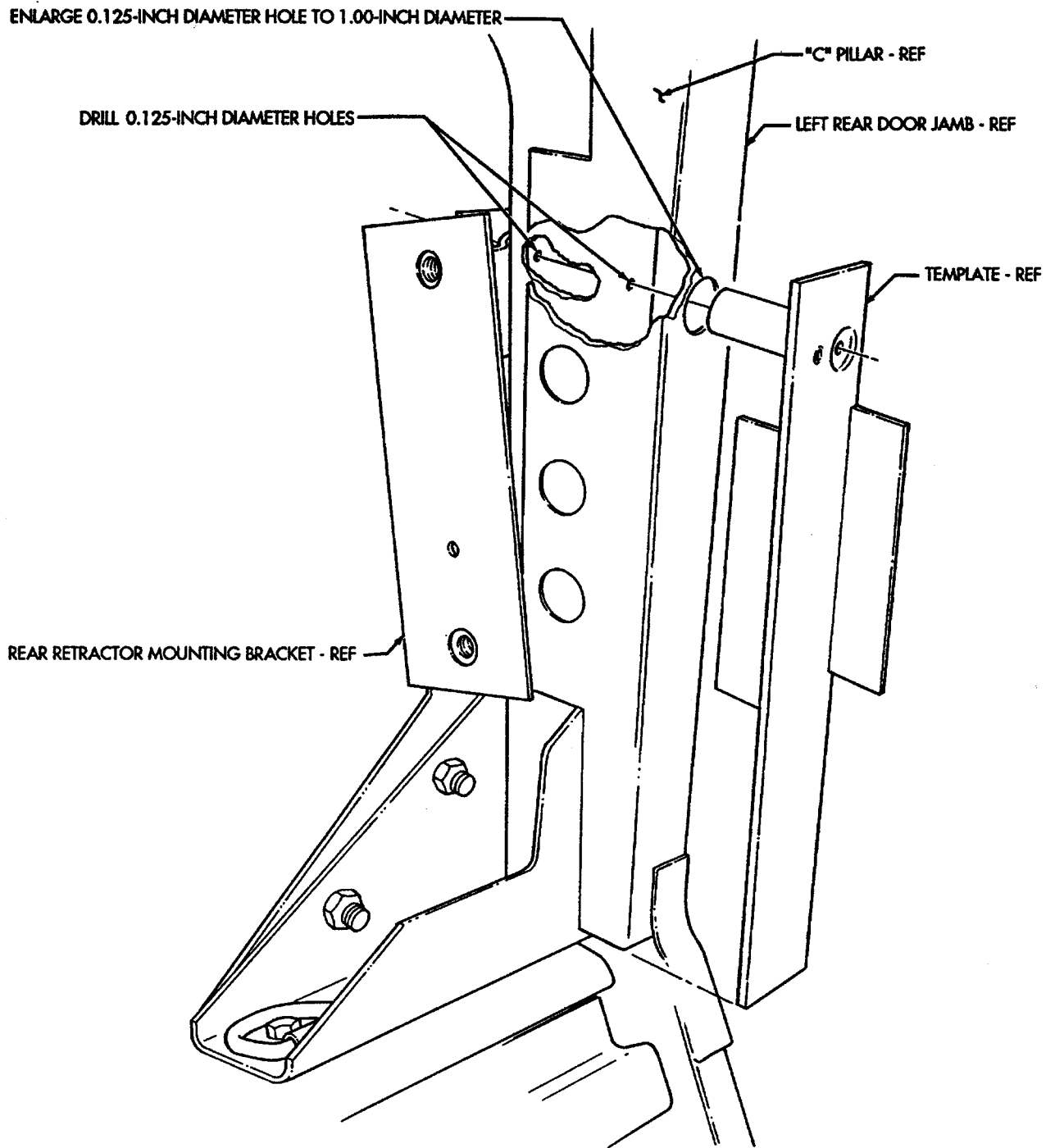

(LEFT SIDE SHOWN, RIGHT SIDE OPPOSITE)
FIGURE 63

ENLARGE 0.125-INCH DIAMETER HOLE TO 0.468-INCH DIAMETER HOLE

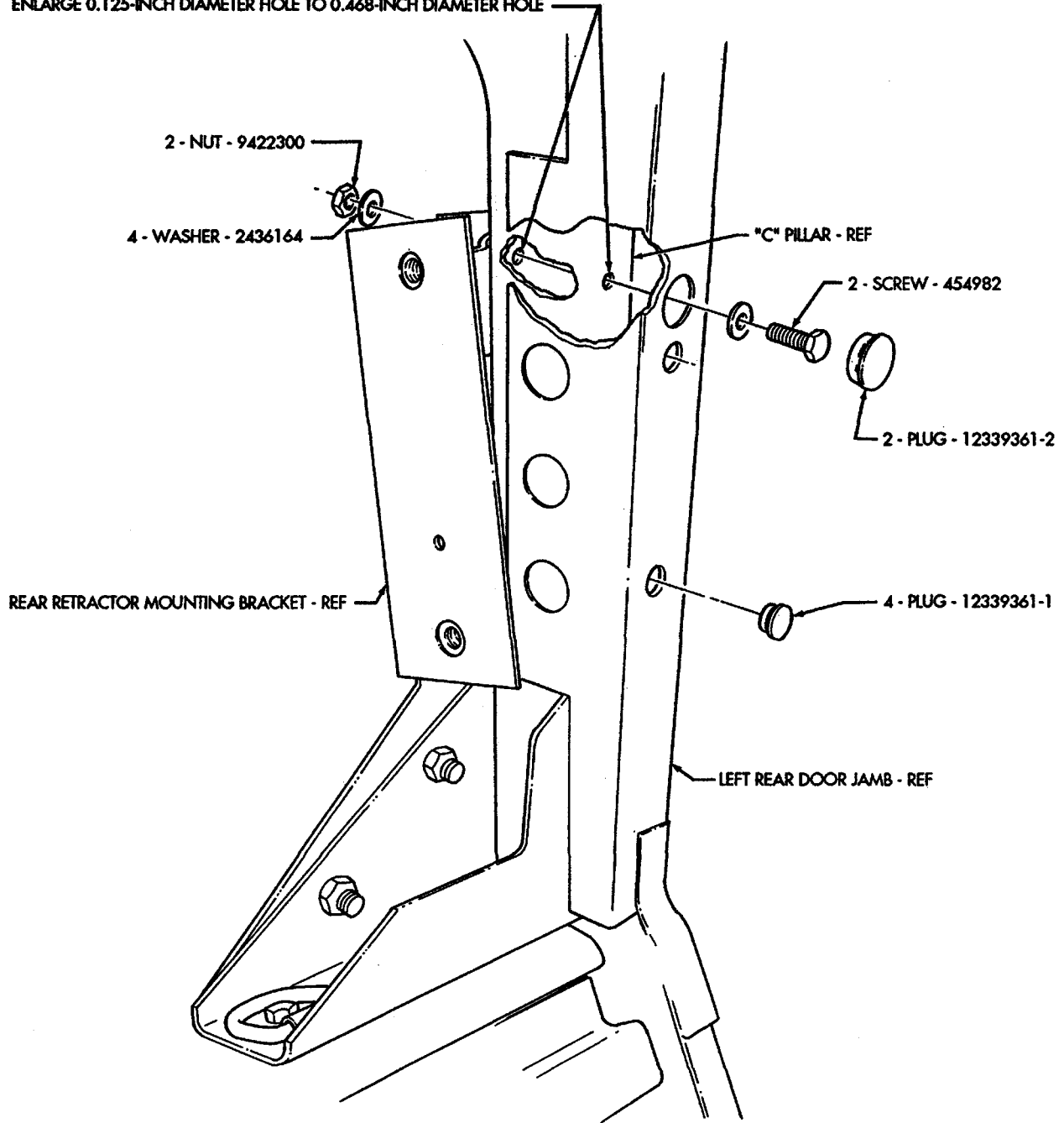

(LEFT SIDE SHOWN RIGHT SIDE OPPOSITE)

FIGURE 64

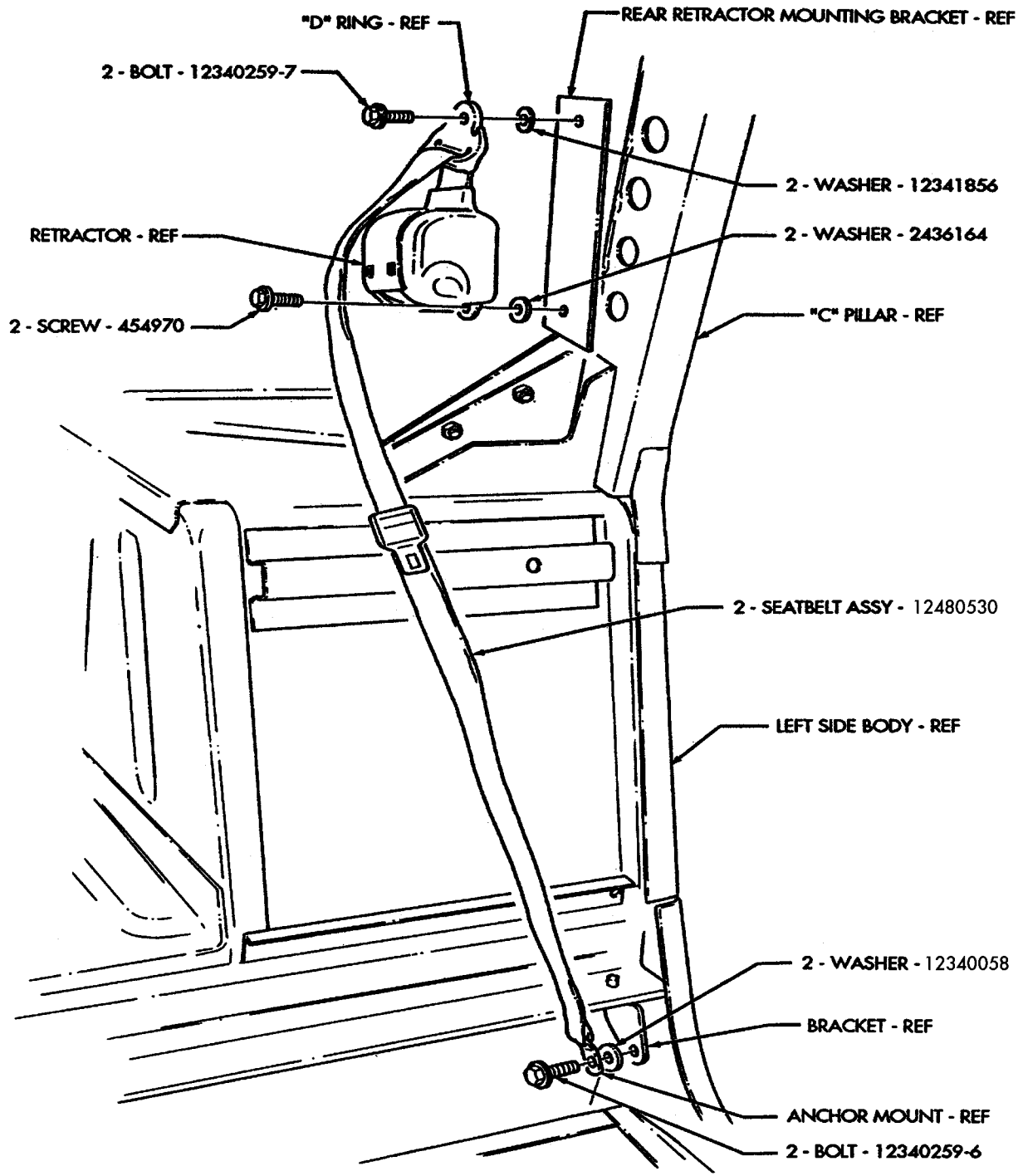

(LEFT SIDE SHOWN, RIGHT SIDE OPPOSITE)

FIGURE 65

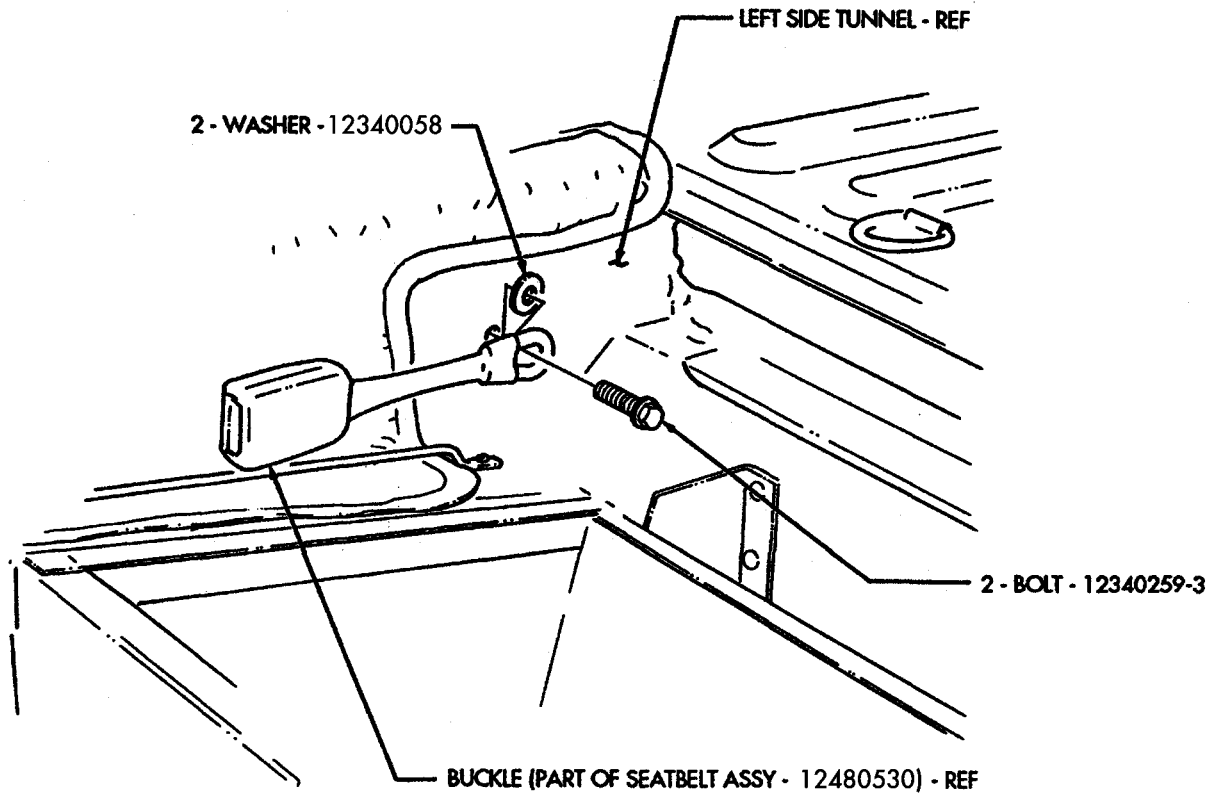

(LEFT SIDE SHOWN, RIGHT SIDE OPPOSITE)

FIGURE 66

ALL DIMENSIONS ARE IN INCHES

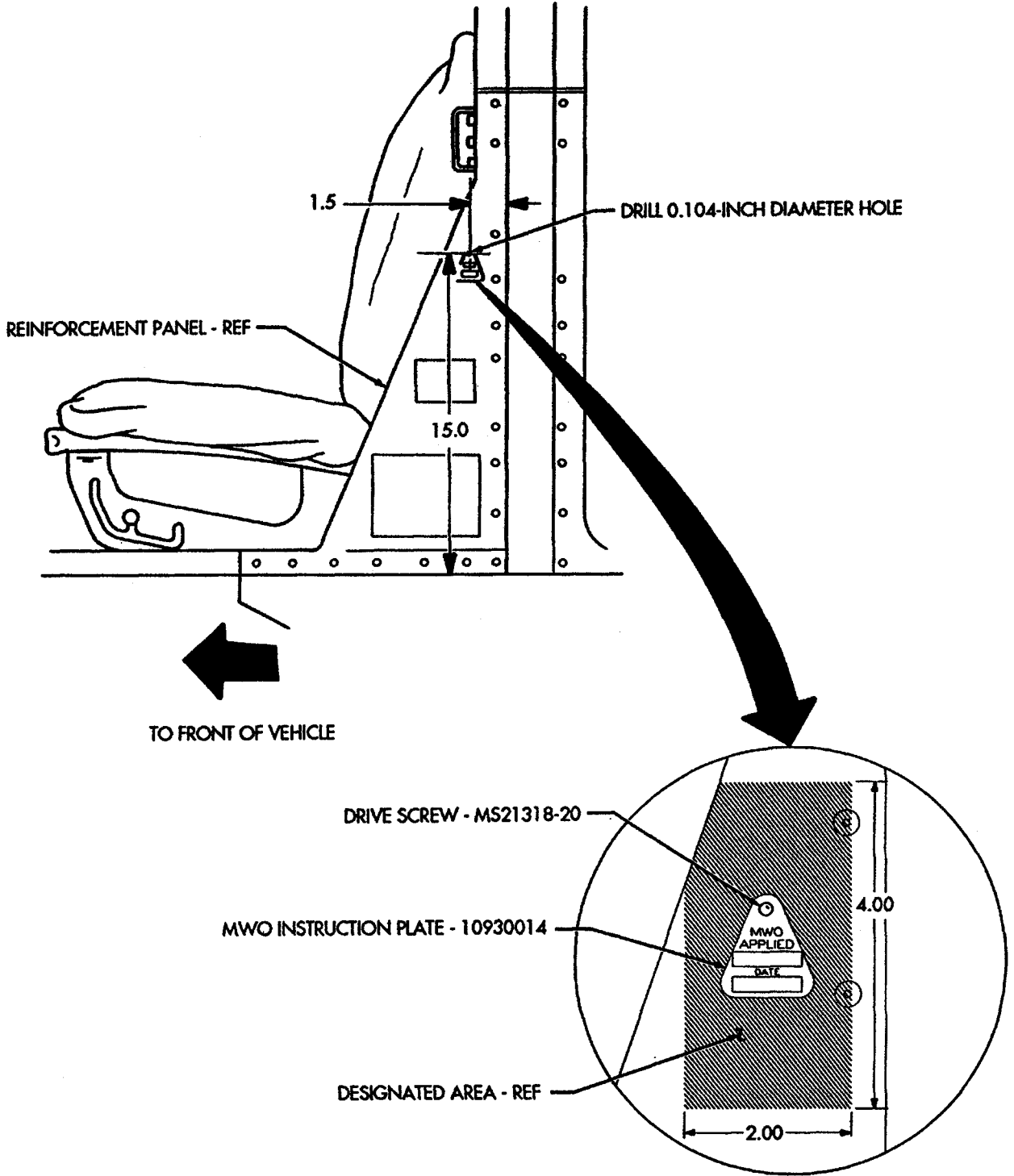
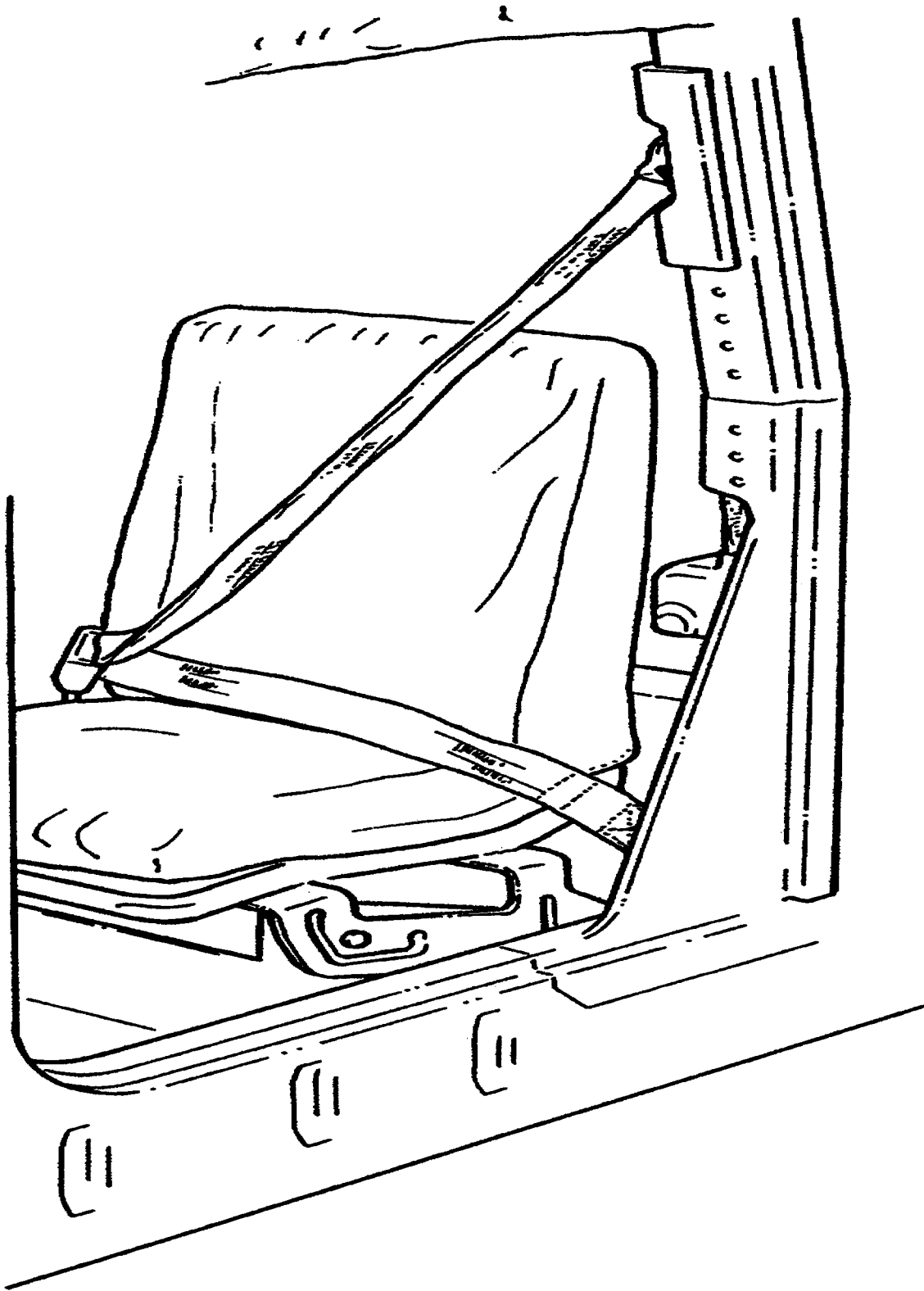
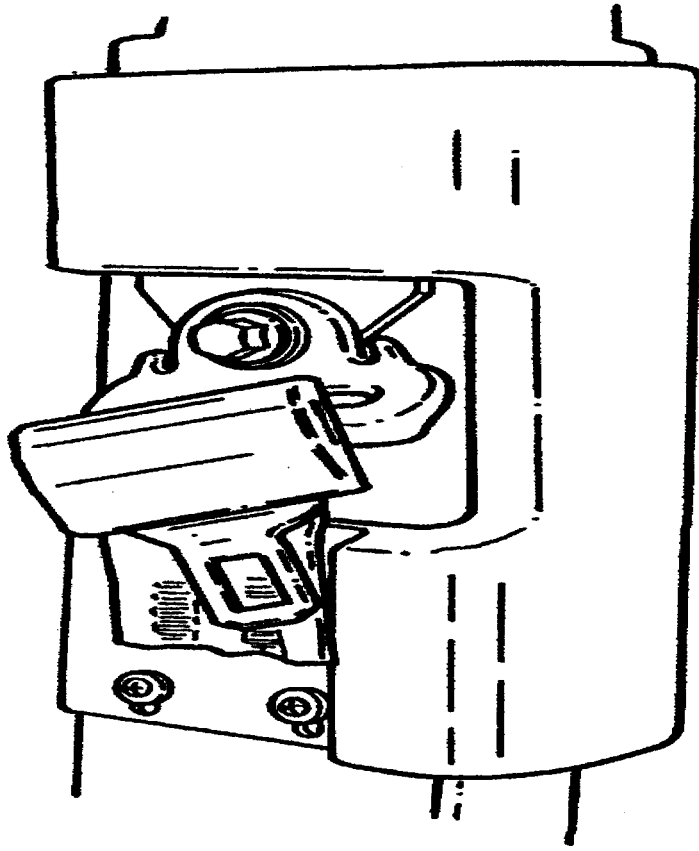

FIGURE 67



FRONT SEAT

FIGURE 68



FOUR-MAN SOFT-TOP OR AMBULANCE SOFT-TOP

FIGURE 69

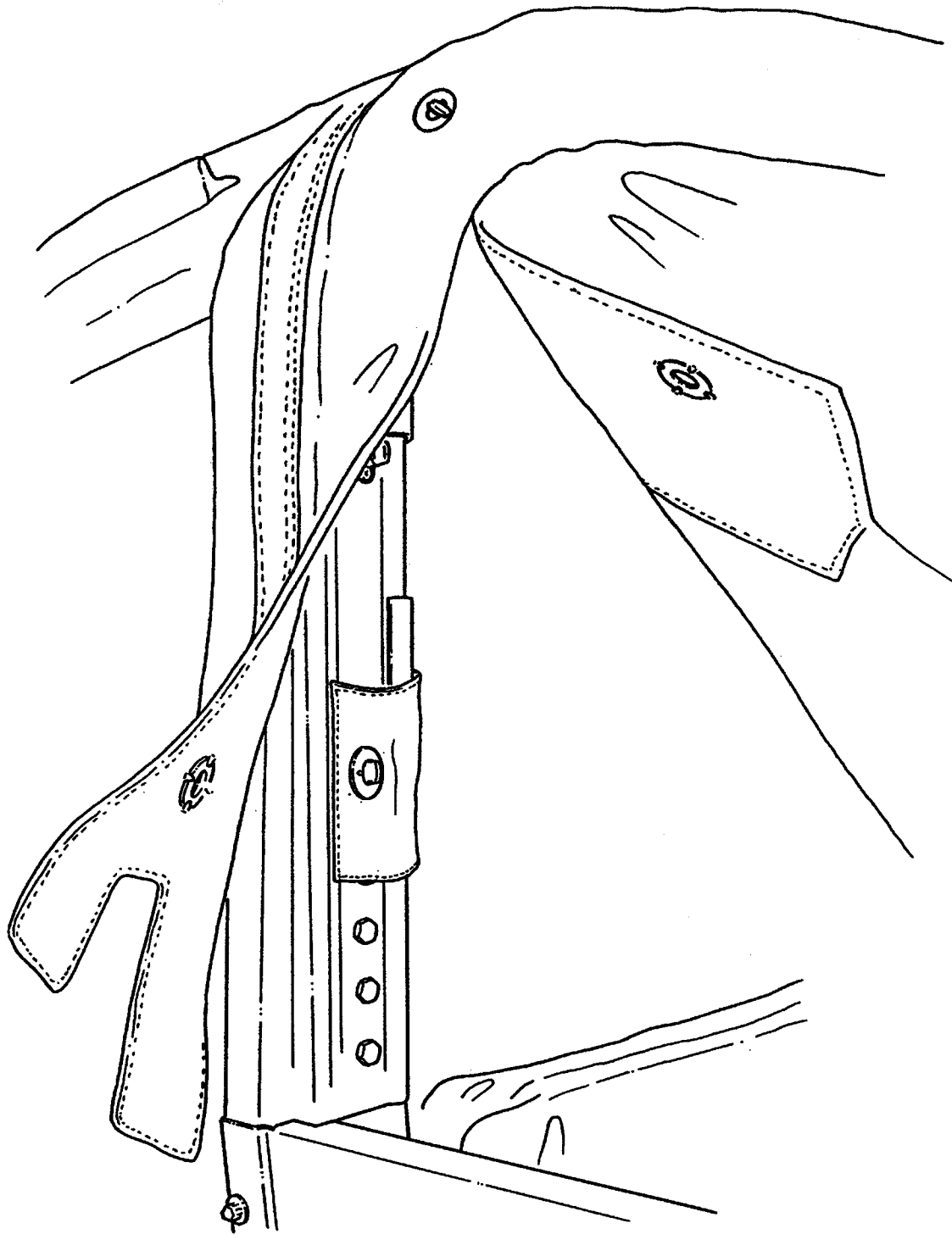

TWO-MAN SOFT-TOP

FIGURE 70

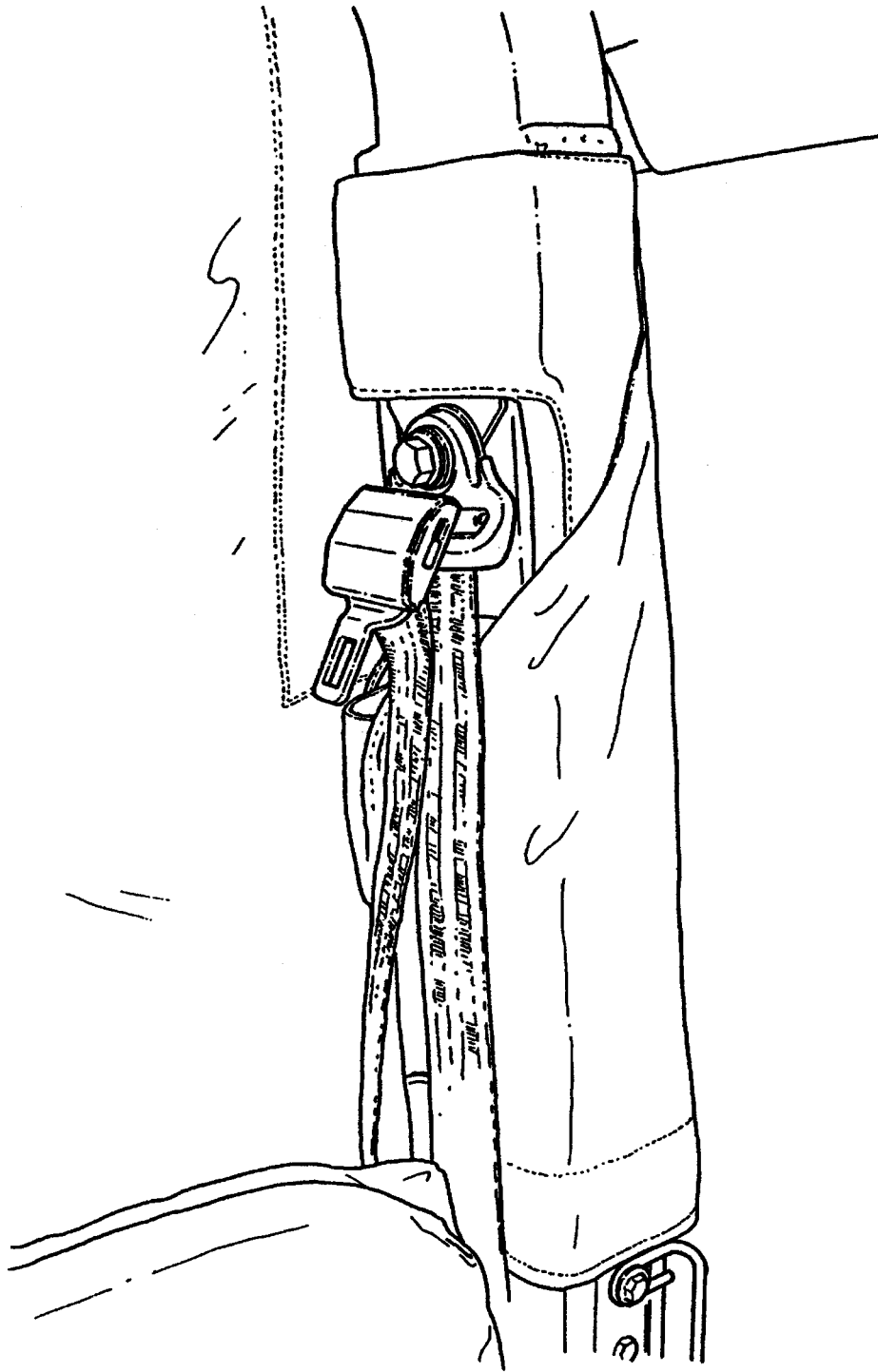

TWO-MAN SOFT-TOP
FIGURE 71

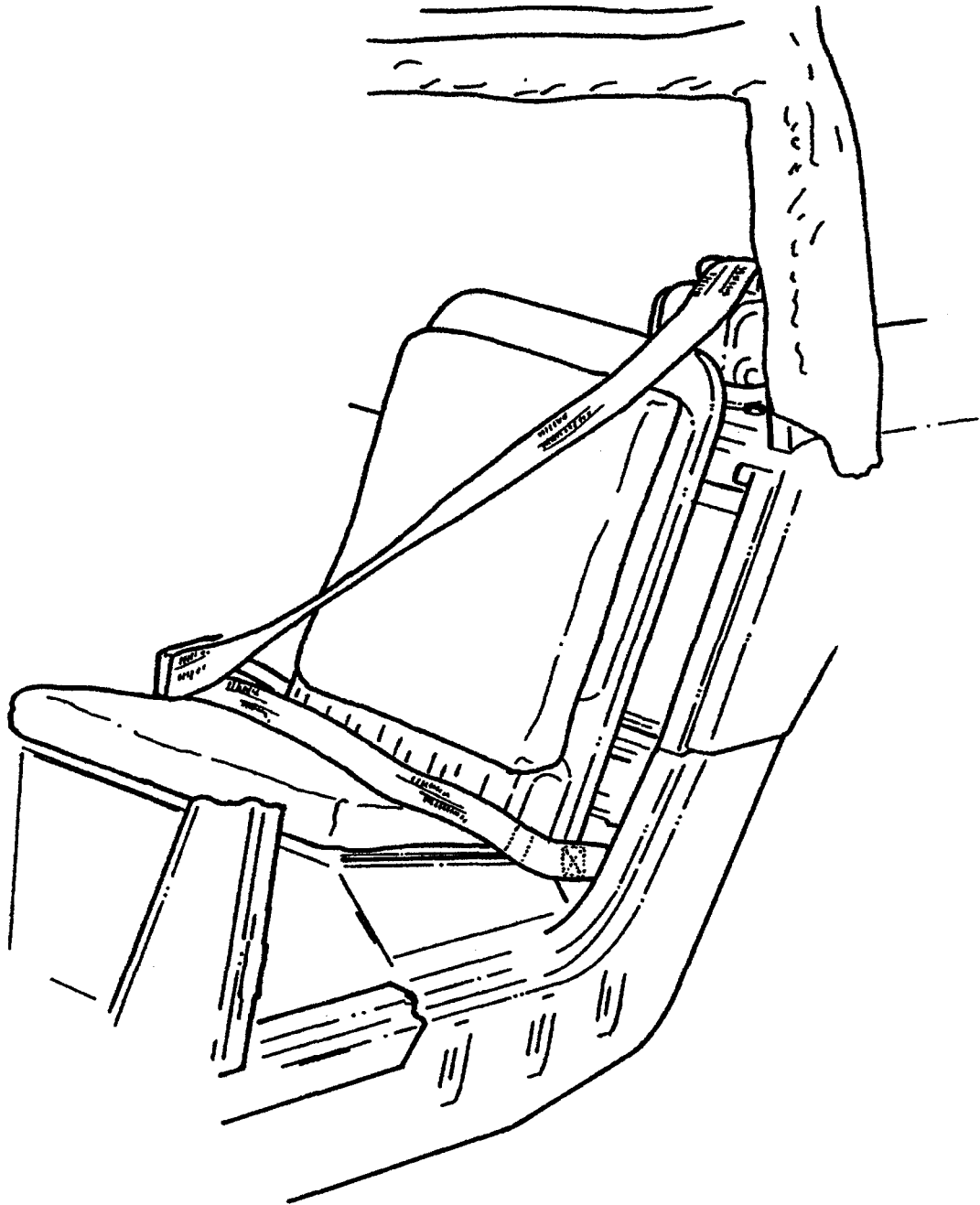

REAR SEAT
FIGURE 72

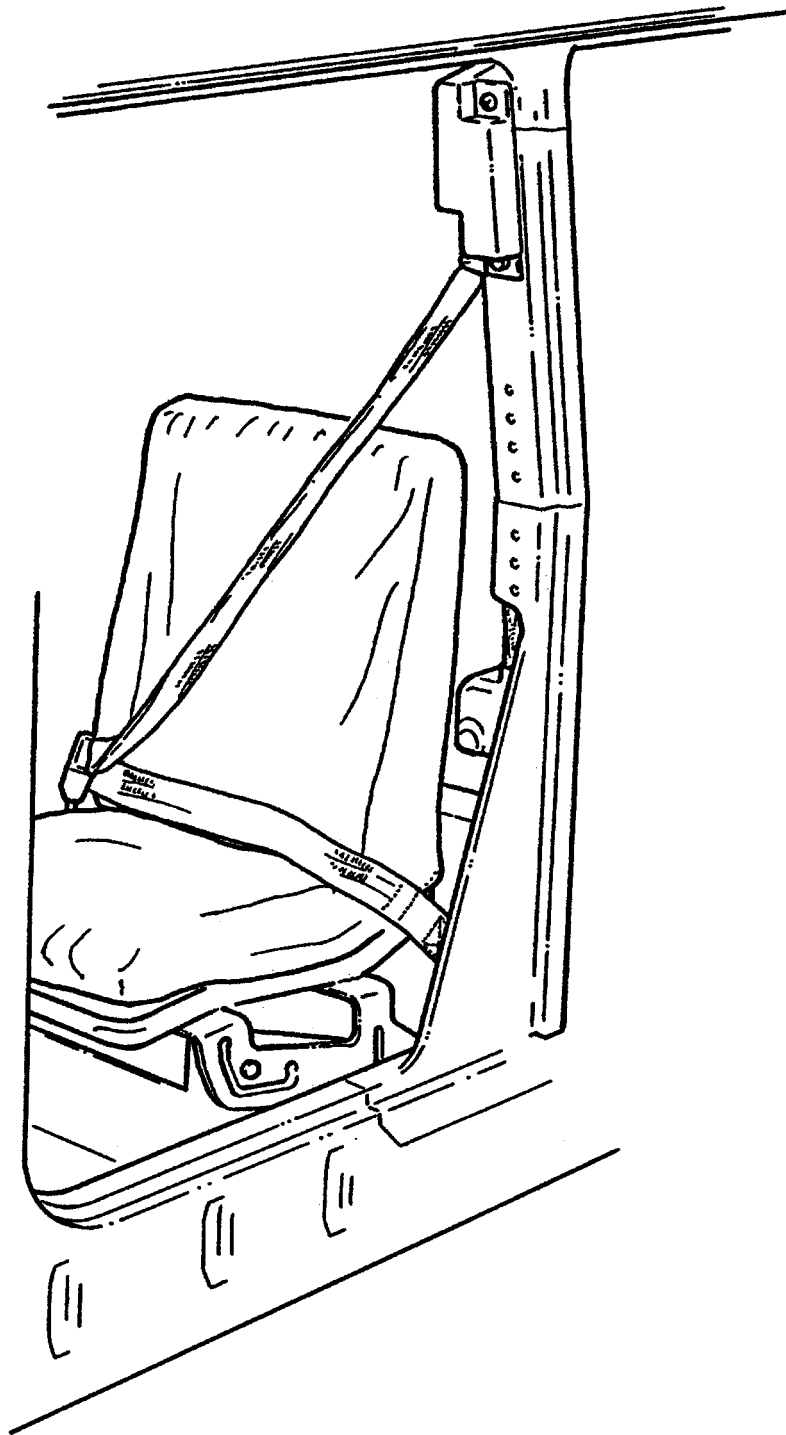

FRONT SEAT

FIGURE 73

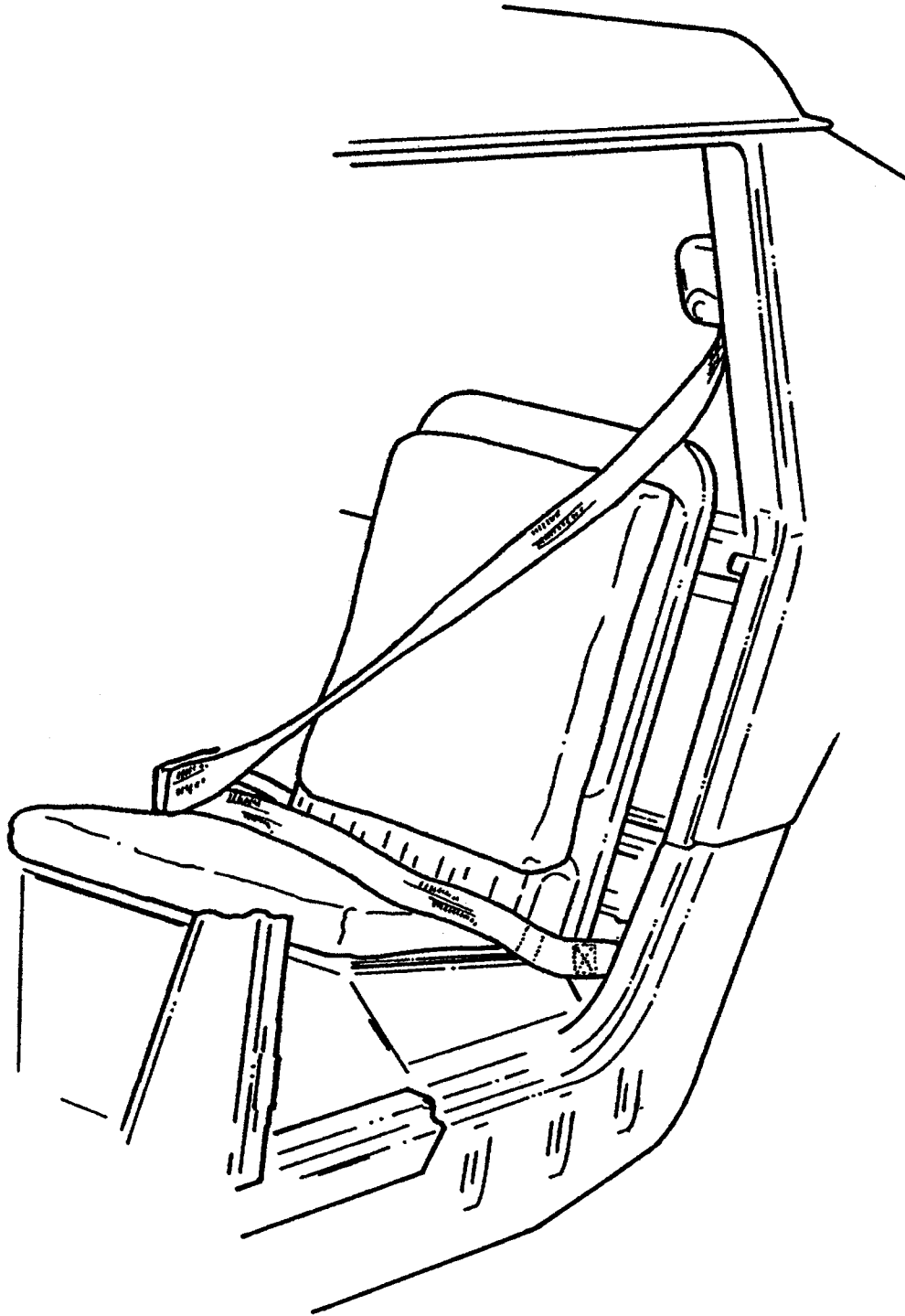

REAR SEAT

FIGURE 74

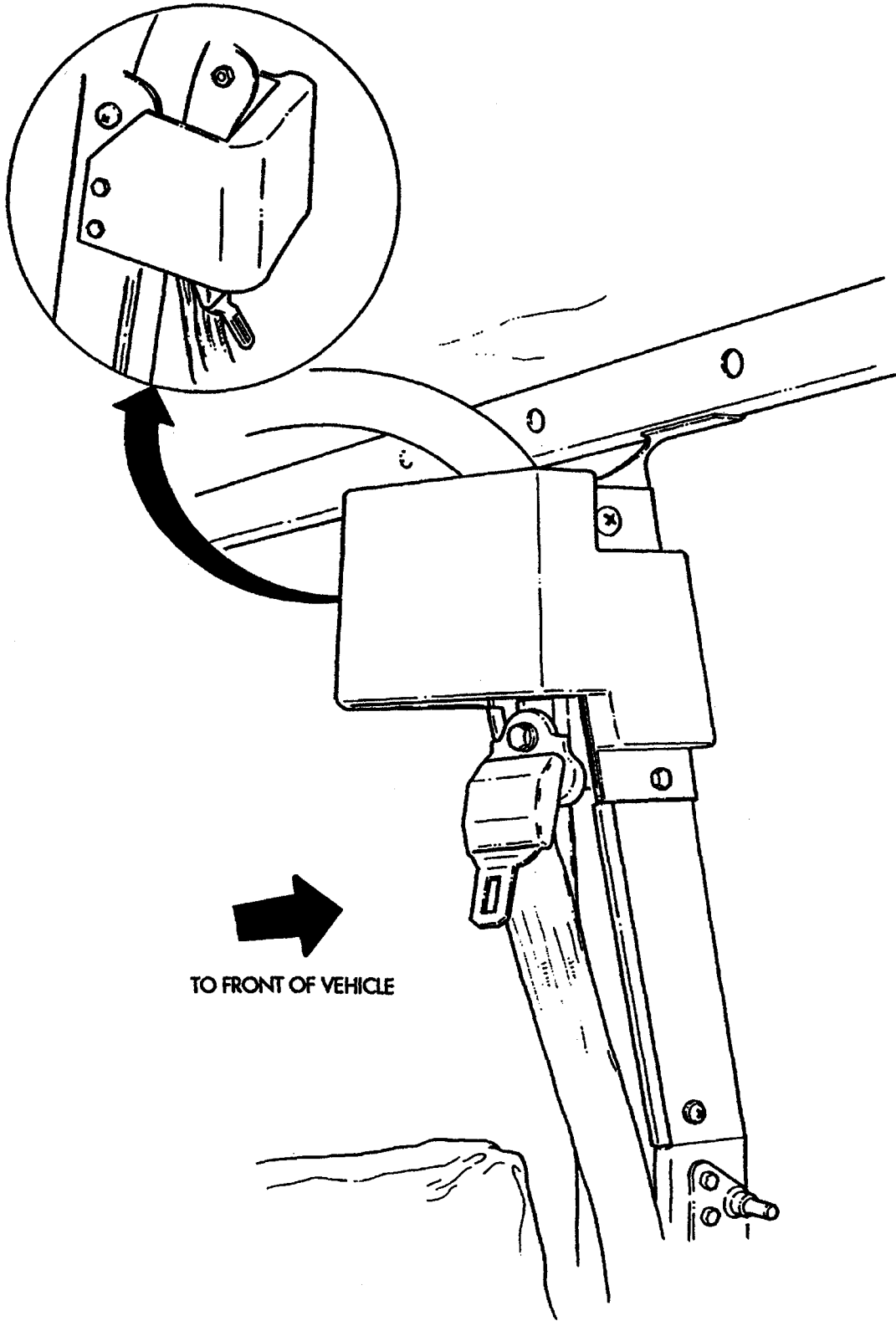

TO FRONT OF VEHICLE

(LEFT SIDE SHOWN)
FIGURE 75

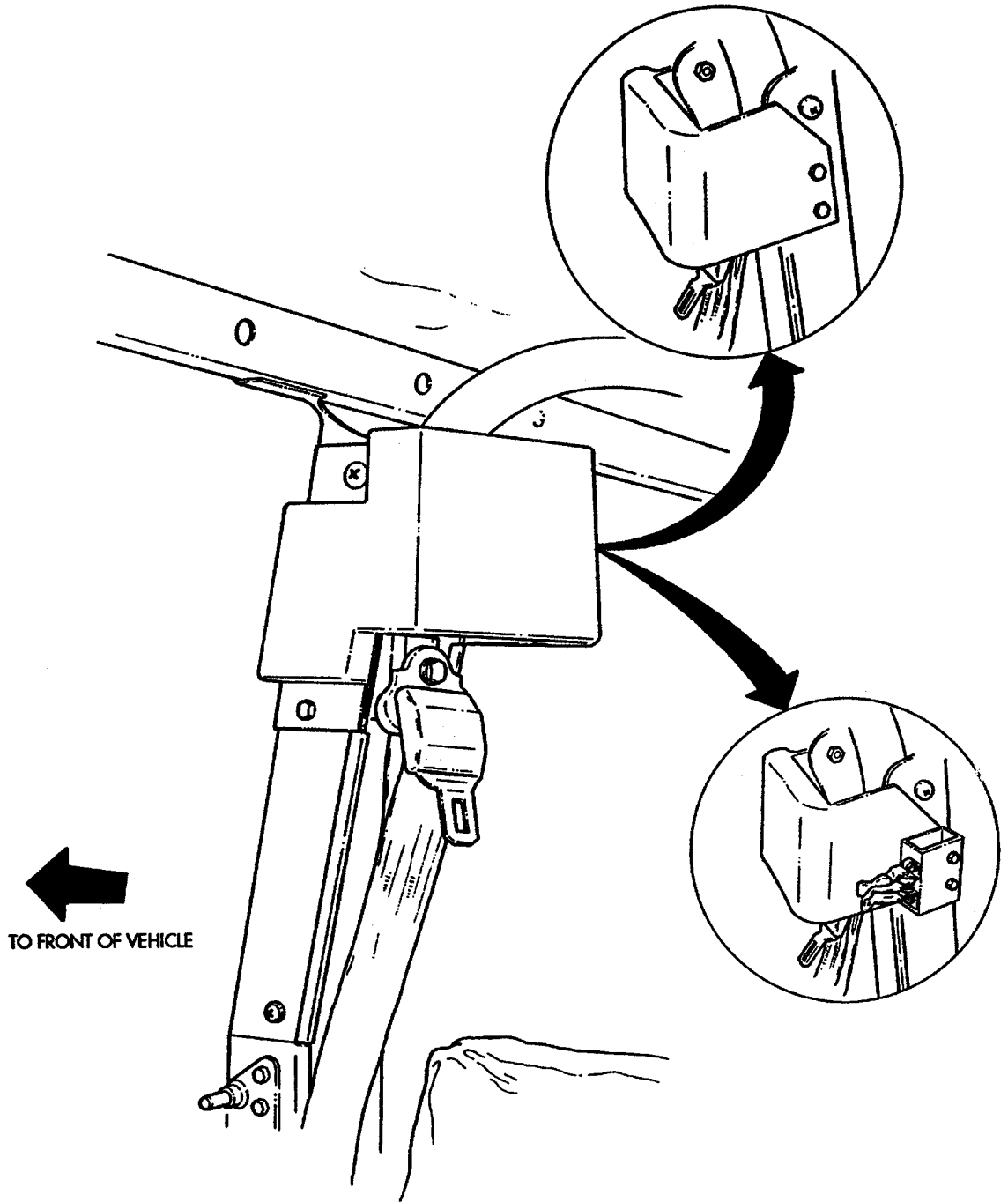

(RIGHT SIDE SHOWN)
FIGURE 76

<p>RECOMMENDED CHANGES TO PUBLICATIONS AND BLANK FORMS</p> <p>For use of this form, see AR 25-30; the proponent agency is OAASA</p>	<p>Use Part II (<i>reverse</i>) for Repair Parts and Special Tool Lists (RPSTL) and Supply Catalogs/Supply Manuals (SC/SM).</p>	<p>DATE</p>
--	---	-------------

<p>TO: (<i>Forward to proponent of publication or form</i>) (<i>Include ZIP Code</i>)</p>	<p>FROM: (<i>Activity and location</i>) (<i>Include ZIP Code</i>)</p>
---	---

PART I - ALL PUBLICATIONS (EXCEPT RPSTL AND SC/SM) AND BLANK FORMS

<p>PUBLICATION/FORM NUMBER MWO 9-2320-280-35-2</p>	<p>DATE 1 JUNE 1996</p>	<p>TITLE 3-POINT SEATBELT RESTRAINT</p>
--	-----------------------------	---

ITEM	PAGE	PARA-	LINE	FIGURE NO.	TABLE	RECOMMENDED CHANGES AND REASON

** Reference to line numbers within the paragraph or subparagraph.*

<p>TYPED NAME, GRADE OR TITLE</p>	<p>TELEPHONE EXCHANGE/AUTOVON, PLUS EXTENSION</p>	<p>SIGNATURE</p>
-----------------------------------	---	------------------

TO: <i>(Forward direct to addressee listed in publication)</i>	FROM: <i>(Activity and location) (Include ZIP Code)</i>	DATE
---	--	-------------

PART II - REPAIR PARTS AND SPECIAL TOOL LISTS AND SUPPLY CATALOGS/SUPPLY MANUALS

PUBLICATION NUMBER MWO 9-2320-280-35-2	DATE 1 JUNE 1996	TITLE 3-POINT SEATBELT RESTRAINT
--	----------------------------	--

PAGE NO.	COLM NO.	LINE NO.	NATIONAL STOCK NUMBER	REFERENCE NO.	FIGURE NO.	ITEM NO.	TOTAL NO. OF MAJOR ITEMS SUPPORTED	RECOMMENDED ACTION

PART III - REMARKS *(Any general remarks or recommendations, or suggestions for improvement of publications and blank forms. Additional blank sheets may be used if more space is needed.)*

TYPED NAME, GRADE OR TITLE	TELEPHONE EXCHANGE/AUTOVON, PLUS EXTENSION	SIGNATURE
-----------------------------------	---	------------------

By order of the Secretary of the Army:

DENNIS J. REIMER
GENERAL, UNITED STATES ARMY
Chief of Staff

Official:



JOEL B. HUDSON

*Administrative Assistant to the
Secretary of the Army*

01969

DISTRIBUTION:

To be distributed in accordance with DA Form 12-38-E, block 1009, requirements for MWO 9-2320-280-35-2.

PIN: 074681-000