

# **TM 5-4930-217-14**

**DEPARTMENT OF THE ARMY TECHNICAL MANUAL**

---

**OPERATOR, ORGANIZATIONAL, DIRECT SUPPORT AND GENERAL  
SUPPORT MAINTENANCE MANUAL**

**LUBRICATING AND SERVICING UNIT: POWER OPERATED;  
TRAILER MOUNTED, 23 CFM COMPRESSOR, RECIPROCATING  
GASOLINE DRIVEN (ELLIOTT MACHINE MODEL ENG-3)**

**FSN 4930-935-4451**

---

This copy is a reprint which includes current  
pages from Changes 1 through 5.

**HEADQUARTERS, DEPARTMENT OF THE ARMY**

**21 MAY 1968**

## **SAFETY PRECAUTIONS**

### **BEFORE OPERATION**

When inflating tires remain to one side of the tire rather than directly in front of it. Serious injury may result if the tire blows out, or if the rim is forced off.

Keep a fully charged fire extinguisher in good working order, mounted in bracket and ready for quick use.

### **DURING OPERATION**

Do not fill gasoline tank while the engine is in operation.

Do not operate the engine with any part of the air shroud removed.

Do not operate the engine in a closed area unless the exhaust is piped to an open area. The exhaust contains carbon monoxide, a colorless, odorless, deadly poisonous gas.

Care must be observed when using compressed air as small particles of dust, or dirt may be blown about, causing bodily injury.

### **AFTER OPERATION**

Use only approved solvents for cleaning the parts of the lubricating and servicing unit. Never use gasoline.

Before disassembly of the equipment, relieve all pressure in tank and compressor.

Stop all operation when cleaning, adjusting, or lubricating the unit being serviced.

CHANGE }  
No. 5 }

HEADQUARTERS  
DEPARTMENTS OF THE ARMY  
WASHINGTON, D. C., 20 October 1986

Operator, Organizational, Direct Support and  
General Support Maintenance Manual

LUBRICATING AND SERVICING UNIT: POWER OPERATED;  
TRAILER MOUNTED, 23 CFM COMPRESSOR, RECIPROCATING  
GASOLINE DRIVEN (ELLIOTT MACHINE MODEL ENG-3)

FSN 4930-935-4451

TM 5-4930-217-14, 21 May 1968, is changed as follows:

Page 3-8, paragraph 3-17 is changed to read:

"Maintain proper tire pressure which is 50 pounds normal and 40 pounds on sandy or rough terrain."

Page 3-12, paragraph 3-41 is deleted.

Page 3-13, figure 3-7 is deleted.

Add new page 4-2 and new figure 4-1.

Page C-2, Group 0100, Engine, assembly gasoline, Column 3, Replace, is changed from "O" to "F." Column 3, Repair, is changed from "F" to "H."

Page C-6. Reference Code A-H is changed to read:

"For Maintenance Allocation Chart relative to the Military Standard Engine Model P/N 13206E0000-3, refer to TM 5-2805-203-14."

4-5. Engine Assembly

a. Removal.

(1) Remove enclosure as described in paragraph 3-37.

(2) Disconnect the fuel line, choke control cable and the throttle control cable before removing engine.

(3) Loosen the four bolts, nuts, and washers attaching the engine (7, fig. 3-7) to the mounting base (8) on the tank (41).

(4) Tag and disconnect electrical leads to the starter assembly and oil pressure gage on control panel from oil pressure transmitter (44).

(5) Remove the two compressor drive belts (39).

(6) Remove engine attaching hardware and remove the engine.

b. Installation.

(1) Lower engine assembly (7, fig. 3-6) over mounting plate holes being certain to align holes in engine bracket mounting base (8).

(2) Install attaching hardware and finger tighten. Final tightening is accomplished after installation and adjustment of drive belts (39 and 40). Refer to paragraph 3-10 for adjustment of drive belts.

(3) Install components to the engine assembly in the reverse order of removal.

---

1 Belt guard	17 Elbow	33C Nut (2)
1A Cap screw (4)	18 Coupling	34 Bracket
2 Flat washer (4)	19 Tee	35 Generator
3 Nut (4)	20 Nipple	36 Support
5 Set screw	21 Bushing	36A Bolt
6 Exhaust diverter	22 Nipple	36B Washer
6A Cap screw (2)	23 Valve	37 Adjusting link
6B Lock washer (2)	24 Nipple	38 Belt guard
6C Nut (2)	25 Tee	38A Bolt
7 Engine	26 Safety valve	39 Compressor belt (2)
8 Mounting base	27 Starter	40 Generator belt
9 Compressor	28 Extension	40A Bolt
10 Mounting	29 Nipple	40B Washer
11 Trough	30 Elbow	40C Nut
12 Lever	31 Nipple	41 Air receiver tank
13 Throttling device	32 Adapter	42 Bracket
14 Elbow	33 Exhaust diverter	43 Low oil pressure switch
15 Tube assembly	33A Cap screw (2)	44 Oil pressure transmitter
16 Nipple	33B Lock washer (2)	45 Tee

Figure 4-1. Engine, compressor and air tank receiver assembly.

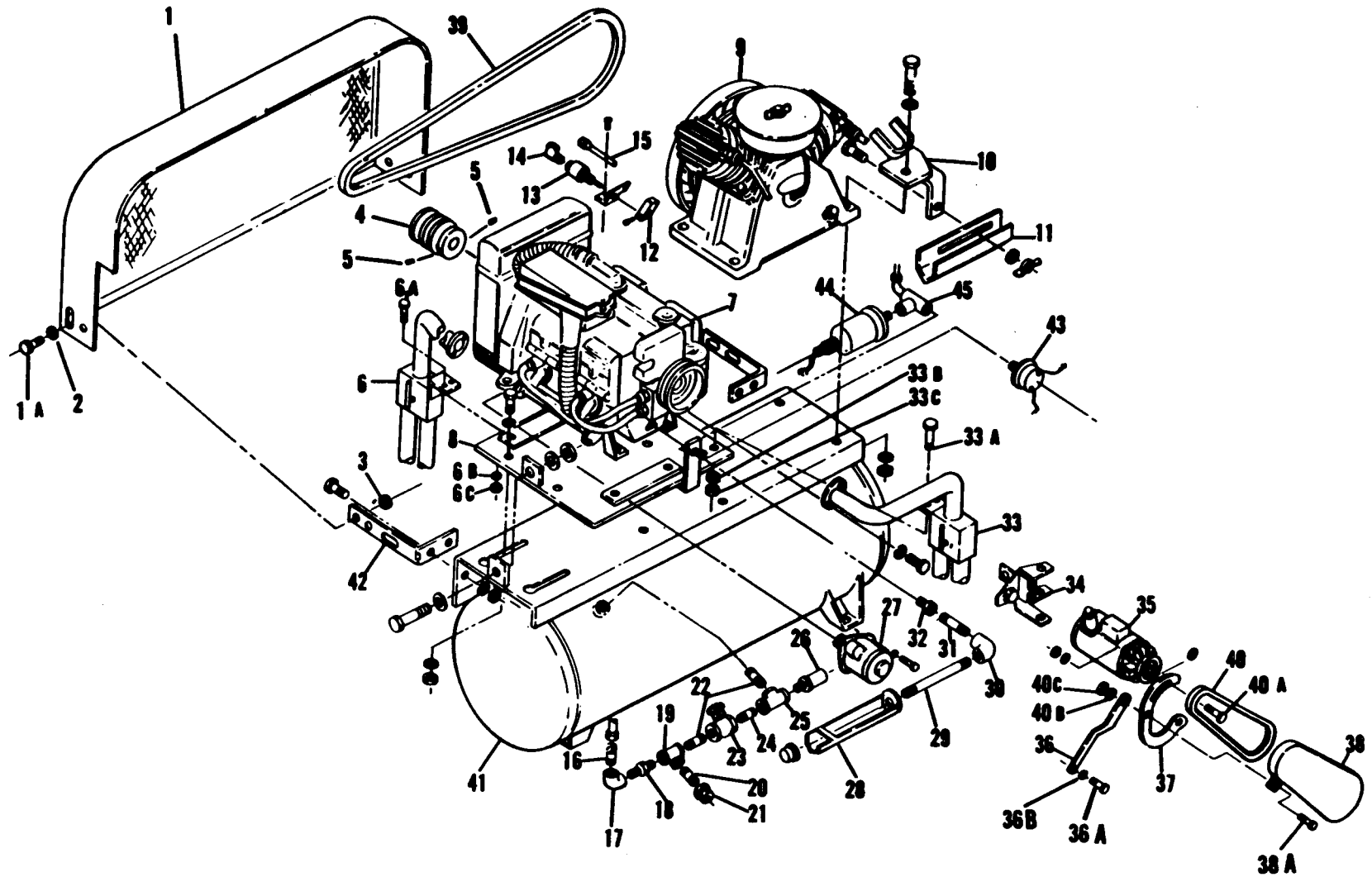

MEC 4930-217-14/3-7

Figure 4-1. Continued.

**By Order of the Secretary of the Army:**

**JOHN A. WICKHAM, JR.**  
*General, United States Army*  
*Chief of Staff*

**Official:**

**R. L. DILWORTH**  
*Brigadier General, United States Army*  
*The Adjutant General*

**DISTRIBUTION:**

To be distributed in accordance with DA Form 12-25A, Operator, Organizational, Direct Support and General Support Maintenance requirements for Lubricating and Service Unit, Gas Driven, Trailer Mounted, 23 CFM (ENG 3).

CHANGE }  
No. 4 }

HEADQUARTERS  
DEPARTMENT OF THE ARMY  
WASHINGTON, D. C., 19 June 1975

**Operator, Organizational, Direct Support  
and General Support Maintenance Manual  
LUBRICATING AND SERVICING UNIT: POWER  
OPERATED; TRAILER MOUNTED 23 CFM  
COMPRESSOR RECIPROCATING, GASOLINE DRIVEN (ELLIOTT)  
(MACHINE MODEL ENG-3)  
NSN 4930-00-935-4451**

TM 5-4930-217-14, 21 May 1968, is changed as follows:

The title is changed as shown above.

*Page 2 of Cover.* Add to Safety Precautions:

**WARNING**

During operation in hot, rainy, or humid conditions the exhaust heat diverter must be turned so as to divert the exhaust gas directly to the atmosphere.

*Page 2-16. Paragraph 2-29.* Add the following after paragraph b(4):

**WARNING**

During operation in hot, rainy, or humid conditons the exhaust heat diverter must be turned so as to divert the exhaust gas directly to the atmosphere.

By Order of the Secretary of the Army:

Official:

FRED C. WEYAND  
*General, United States Army*  
*Chief of Staff*

VERNE L. BOWERS  
*Major General, United States Army*  
*The Adjutant General*

**Distribution:**

To be distributed in accordance with DA Form 12-25A, (qty rqr block no. 138) Organizational maintenance requirements for Lubricating and Servicing Equipment.



Change }  
No. 3 }

HEADQUARTERS  
DEPARTMENT OF THE ARMY  
Washington, D. C. 15 July 1974

**Operator's, Organizational, Direct Support, General  
Support, Maintenance Manual  
LUBRICATING AND SERVICING UNIT; POWER OPERATED;  
23 CFM COMPRESSOR, RECIPROCATING; GASOLINE DRIVEN  
(ELLIOTT MACHINE MODEL ENG-3) FSN 4930-935-4451**

TM 5-4930-217-14, 21 May 1968, is changed as follows:

*Reverse of cover.* Add to Safety Precautions:

**WARNING**

Operation of this equipment presents a NOISE HAZARD to personnel in the area. The noise level exceeds the allowable limits for unprotected personnel. Wear ear muffs or ear plugs which were fitted by a trained professional.

**WARNING**

Cleaning solvent, PD-680, is POTENTIALLY DANGEROUS CHEMICAL. Do not use near open flame.

*Page 1-1, paragraph 1-1d, Line 6, is changed to read: Commander, US Army Troop Support Command, ATTN: AMSTS-MPP, 4300 Goodfellow Boulevard, St. Louis, MO 63120.*

*Page 2-4, paragraph 2-5e is added.*

*e. Noise Hazard Warning Signs. Signs conforming to provisions of AR 385-30 will be erected*

in the area to provide notification of NOISE HAZARD. The signs should read:

**WARNING**

NOISE HAZARD EQUIPMENT  
HEARING PROTECTION REQUIRED

*Page 2-8, paragraph 2-10c, add:*

**WARNING**

Operation of this equipment presents a NOISE HAZARD to personnel in the area. Wear ear muffs or ear plugs which were fitted by a trained professional.

*Page 3-1, paragraph 3-4c, add:*

**WARNING**

Dry cleaning solvent, PD-680, used for cleaning is POTENTIALLY DANGEROUS CHEMICAL. Do not use near open flame. Flash point of solvent is 100F - 138F.

By Order of the Secretary of the Army:

**CREIGHTON W. ABRAMS**  
*General, United States Army*  
*Chief of Staff*

Official:

**VERNE L. BOWERS**  
*Major General, United States Army*  
*The Adjutant General*

**Distribution:**

To be distributed in accordance with DA Form 12-25A (qty rqr block No. 137) Organizational Maintenance requirements for Lubricating and Servicing Equipment.

Changes in force: C 1 and C 2

**TM 5-4930-217-14**

**C 2**

HEADQUARTERS  
DEPARTMENT OF THE ARMY  
Washington, D. C., 22 April 1973

Change }  
No 2 }

**Operator, Organizational, Direct Support and  
General Support Maintenance Manual  
LUBRICATING AND SERVICING UNIT: POWER  
OPERATED; TRAILER MOUNTED, 23 CFM COMPRESSOR,  
RECIPROCATING, GASOLINE DRIVEN (ELLIOTT  
MACHINE MODEL ENG-3)  
FSN 4930-935-4451**

TM 5-4930-217-14, 21 May 1968, is changed as follows:

*Page 2-1, paragraph 2-3.* Paragraph *i* is added as follows:

*i.* Maintenance and operating supplies required for initial 8 hours of operation for the lubricating and service unit are contained in table 2-0.

Table 2-0. MAINTENANCE AND OPERATING SUPPLIES

(1) Component application	(2) Federal stock number	(3) Description	(4) Quantity required f/initial operation	(5) Quantity required f/h hra operation	(6) Notes
0306 — FUEL TANK	9130-160-1818	FUEL, GASOLINE: Bulk as follows			
		Automotive combat type I	10 gal (4)	(5)	
	9130-160-1830	Automotive combat type II	10 gal (4)	(5)	
2207 — ALCOHOL DISPENSER		ALCOHOL, DENTURED:			
	6810-543-7694	1 qt btl as follows: Alcohol	1/4 qt		
5001 — CRANKCASE		OIL, LUBRICATING: 55 gal drum as follows:			
	9150-265-9436 (2)	OE-30	2 qt (1)	(3)	
	9150-265-9429 (2)	OE-10	2 qt (1)	(3)	
	9150-242-7604 (2)	OES	2 qt (1)	(3)	
7201 — LUBRICATING OIL RESERVOIR		OIL, LUBRICATING: 55 gal drum as follows:			
	9150-265-9436 (2)	OE-30	27 gal	(6)	
	9150-265-9429 (2)	OE-10	27 gal	(6)	
	9150-242-7602 (2)	OES	27 gal	(6)	
7201 — LUBRICATING GEAR OIL RESERVOIR		LUBRICATING OIL, GEAR: 55 gal drum as follows:			
	9150-577-5845 (2)	GO-90	27 Gal	(7)	
	9150-257-5443 (2)	GOS	27 gal	(7)	

- (1) Includes quantity of oil to fill compressor oil system as follows: 2 qt. compressor.
- (2) See FSC C9100-IL for additional data and requisitioning procedures.
- (3) See current lubrication chart for grade application and replenishment intervals.
- (4) Tank capacity.
- (5) See TM 5-2805-203-14 for average fuel consumption.
- (6) Quantity of oil to fill oil reservoir.
- (7) Quantity of gear oil to fill reservoir.
- (8) 2 ea - 100-lb drums are required to fill grease reservoir.

**Table 2-0. MAINTENANCE AND OPERATING SUPPLIES— (Continued)**

(1) Component application	(2) Federal stock number	(3) Description	(4) Quantity required /initial operation	(5) Quantity required /h hrs operation	(6) Notes
7201 — LUBRICATING GREASE RESERVOIR	9150-530-7369	GREASE, AUTOMOTIVE AND ARTILLERY: 120 lb drum as follows: GAA	175 lb	(8)	

Page B-1. Appendix B is superseded as follows:

## APPENDIX B BASIC ISSUE ITEM LIST AND ITEMS TROOP INSTALLED OR AUTHORIZED

### Section I. INTRODUCTION

#### B-1. Scope

This appendix lists basic issue items, items troop installed or authorized which accompany the lubricating and servicing unit and are required by the crew/operator for operation, installation, or operator's maintenance.

#### B-2. General

This basic issue items, items troop installed or authorized list is divided into the following sections:

*a. Basic Issue Items List — Section II.* Not applicable.

*b. Items Troop Installed or Authorized List — Section III.* A list in alphabetical sequence of items which, at the discretion of the unit commander, may accompany the end item, but are NOT subject to be turned in with the end item.

#### B-3. Explanation of Columns

The following provides an explanation of columns

in the tabular list of Basic Issue Items List, Section II, and Items Troop Installed or Authorized, Section III.

*a. Source, Maintenance, and Recoverability Code (s) (SMR):* Not applicable.

*b. Federal Stock Number.* This column indicates the Federal stock number assigned to the item and will be used for requisitioning purposes.

*c. Description.* This column indicates the Federal item name and any additional description of the item required.

*d. Unit of Measure (U/M).* A 2-character alphabetic abbreviation indicating the amount or quantity of the item upon which the allowances are based, e.g., ft, ea, pr, etc.

*e. Quantity Authorized (Items Troop Installed or Authorized Only).* This column indicates the quantity of the item authorized to be used with the equipment.

### Section III. ITEMS TROOP INSTALLED OR AUTHORIZED LIST

(1) SMR code	(2) Federal stock No.	(3) Ref. No. & Mfr code	(3) Description	Usable on code	(4) Unit of meas	(5) Qty auth
	7520-559-9618	CASE, MANUAL			EA	1

**By Order of the Secretary of the Army:**

**CREIGHTON W. ABRAMS**  
*General, United States Army*  
*Chief of Staff*

**Official:**

**VERNE L. BOWERS**  
*Major General, United States Army*  
*The Adjutant General*

**Distribution:**

To be distributed in accordance with DA form 12-25A (qty rqr block No.138), Organizational maintenance requirements for Lubricating and Servicing Equipment.

**TM 5-4930-217-14**

**C 1**

CHANGE }  
No. 1 }

HEADQUARTERS  
DEPARTMENT OF THE ARMY  
WASHINGTON, D.C., 13 November 1968

**Operator, Organizational, Direct Support and General Support  
Maintenance Manual**

**LUBRICATING AND SERVICING UNIT: POWER OPERATED;  
TRAILER MOUNTED, 23 CFM COMPRESSOR, RECIPROCATING,  
GASOLINE DRIVEN (ELLIOTT MACHINE MODEL ENG-3)**

**FSN 4930-935-4451**

TM 5-4930-217-14, 21 May 1968, is changed as follows:

Page 2-11. Paragraph 2-15*k* and table 2-1 are added as follows:

*k*. The approximate output capacities of the lubricant pumps at various temperatures, are listed in table 2-1.



Table 2-1. Lubricant Pump Performance Data Chart

	-25°F.	75° ± 10°F.	125°F.
Grease Pump.....	6 lb/5 min	10 oz/10 pumping cycles	9 oz/10 pumping cycles
Engine Oil Pump.....	1 gal/50 sec	5 pt/10 pumping cycles	5 pt/10 pumping cycles
Gear Oil Pump.....	1 gal/60 sec	4.5 pt/10 pumping cycles	4.5 pt/10 pumping cycles
Transfer Pump (Pumping Engine Oil).	5 gal/75 sec	15 gal/60 sec	15 gal/60 sec

Page 3-42. Figure number and caption are changed to read as follows:

*Figure 3-30. Metering valves (quarts and pints). (Used only on  
Serial Nos. 84-29943 thru 84-30304 and 86-30305 thru 86-31248).*

By Order of the Secretary of the Army:

W. C. WESTMORELAND,  
General, United States Army,  
Chief of Staff.

Official:

KENNETH G. WICKHAM,  
Major General, United States Army,  
The Adjutant General.

Distribution:

To be distributed in accordance with DA Form 12-25, (qty rqr block No. 138) Section I, Organizational maintenance requirements for Lubricating and Servicing.

OPERATOR, ORGANIZATIONAL, DIRECT SUPPORT AND GENERAL  
 SUPPORT MAINTENANCE MANUAL

LUBRICATING AND SERVICING UNIT: POWER OPERATED;  
 TRAILER MOUNTED, 23 CFM COMPRESSOR, RECIPROCATING  
 GASOLINE DRIVEN (ELLIOT MACHINE MODEL ENG-3)  
 FSN 4930-9354451

	Paragraphs	Page
CHAPTER 1. INTRODUCTION		
Section I. General _____	1-1,1-2	1-1
II. Description and tabulated data -----	1-3-1-5	1-1
CHAPTER 2. INSTALLATION AND OPERATING INSTRUCTIONS		
Section I. Service upon receipt of equipment _____	2-1—2-5	2-1
II. Movement to a new worksite _____	2-6,2-7	2-4
III. Controls and instruments _____	2-8,2-9	2-4
IV. Operation of equipment _____	2-10-2-28	2-8
V. Operation of material used in conjunction with the equipment _____	2-24-2-30	2-14
CHAPTER 3. OPERATOR AND ORGANIZATIONAL MAINTENANCE INSTRUCTIONS		
Section I. Special tools and equipment _____	3-1,3-2	3-1
II. Lubrication _____	3-3,3-4	3-1
III. Preventive maintenance services _____	3-5-3-7	3-1
IV. Operator's maintenance _____	3-8-3-22	3-6
V. Troublsshooting _____	3-23-3-32	3-10
VI. Radio interference suppression _____	3-33-3-35	3-11
VII. Enclosure assembly, battery drawer, toolbox and trouble light _____	3-36-3-39	3-11
VIII. Engine assembly _____	3-40-3-42	3-12
IX. Fuel system _____	3-43-3-48	3-14
X. Exhaust system _____	3-49,3-50	3-16
XI. Drive sheave _____	3-51-3-53	3-16
XII. Electrical system _____	3-54-3-70	3-16
XIII. Wheels, tires and tubes _____	3-71-3-74	3-21
XIV. Service brakes, hydraulic brake system and air brake system _____	3-75--3-81	3-23
XV. Frame assembly _____	3-82-3-91	3-28
XVI. Compressor and components _____	3-92-3-99	3-34
XVII. Hose reel assemblies and controls (used only on serial numbers 69-29737 thru 69-29942) _____	3-100—3-103	3-37
XVIII. Hose reel assemblies (used only on units with serial numbers 84-29943 thru 84-30804 and 86-30305 thru 8-31248) _____	3-104-3-107	3-40
XIX. Lubricating equipment _____	3-108-3-115	3-44
XX. Air pressure gage, compressor relief valve and air receiver tank _____	3-116-3-118	3-47
XXI. Aleohol dispenser, master air valve, lines and fittings _____	3-119,3-120	3-48
CHAPTER 4. DIRECT AND GENERAL SUPPORT MAINTENANCE INSTRUCTIONS		
Section I. General _____	4-1,4-2	4-1
II. Description and tabulated data _____	4-3,4-4	4-1

	Paragraphs	Page
CHAPTER 5.	GENERAL MAINTENANCE INSTRUCTIONS	
Section I.	Special tools and equipment _____	5-1,5-2 5-1
II.	Troubleshooting _____	5-3—5-19 5-1
III.	Removal and installation of major components and auxiliaries -----	5-20—5-24 5-2
CHAPTER 6.	ELECTRICAL COMPONENTS REPAIR INSTRUCTIONS	
Section I.	Generator assembly _____	6-1, 6-2 6-1
II.	Starter assembly -----	6-3,6-4 6-3
CHAPTER 7.	AIR COMPONENT REPAIR INSTRUCTIONS	
Section I.	Compressor assembly _____	7-1,7-2 7-1
II.	Compressor relief valve _____	7-3,7-4 7-5
CHAPTER 8.	LUBRICATING EQUIPMENT REPAIR INSTRUCTIONS	
Section I.	Lubricating unit pumps (used on serial numbers 69-29737 through 69-29942) ____	8-1—8-3 8-1
II.	Lubricating unit pumps and valves (used on serial numbers 84-29943 thru 84-30304 and 86-30305 thru 86-31248) _____	8-4,8-5 8-5
III.	Transfer pump (used on serial numbers 69-29737 thru 69-29942 _____)	8-6,8-7 8-13
IV.	Transfer pump (used on serial numbers 84-29943 thru 84-30304 and 86-30305 thru 86-31248) -----	8-8,8-9 8-15
V.	Hose reel assemblies (used on serial numbers 69-29737 thru 69-29942) -----	8-10,8-11 8-17
VI.	Hose reel assemblies (used on serial numbers 84-29943 thru 84-30304 and 86-30305 thru 85-31248) _____	8-12,8-13 8-18
VII.	Alcohol dispenser _____	8-14,8-15 8-20
CHAPTER 9.	HYDRAULIC BRAKE COMPONENTS	
Section I.	Master cylinder -----	9-1,9-2 9-1
II.	Air relay valve -----	9-3,9-4 9-2
CHAPTER 10.	GENERAL MAINTENANCE	
Section I.	Engine -----	10-1,10-2 10-1
II.	Trailer frame, base skid, axle assembly and enclosure assembly _____	10-3—10-7 10-1
APPENDIX A.	REFERENCES -----	A-1
B.	BASIC ISSUE ITEMS LIST AND MAINTENANCE AND OPERATING SUPPLIES -----	B-1
C.	MAINTENANCE ALLOCATION CHART _____	C-1
INDEX _____		I-1

# CHAPTER 1

## INTRODUCTION

---

### Section I. GENERAL

#### 1-1. Scope

*a.* These instructions are published for use by personnel to whom the Lubricating and Servicing Unit is issued. Chapters 1 through 3 provide information on operation, preventive maintenance services, and organizational maintenance of the equipment, accessories, components, and attachments. Chapters 4 through 10 provide information for direct and general support maintenance. Also included are descriptions of main units and their functions in relationship to other components.

*b.* Appendix A contains a list of publications applicable to this manual. Appendix B contains the list of basic issue items authorized the operator of this equipment and the list of maintenance and operating supplies required for initial operation. Appendix C contains the maintenance allocation chart. Organizational, direct and general support repair parts and special tools are listed in TM 5-4930-217-24P.

*c.* Numbers in parentheses following nomenclature callouts on illustrations indicate quan-

tity; numbers preceding nomenclature callouts indicate preferred maintenance sequence.

*d.* Reports of errors, omissions, and recommendations for improving this publication by the individual user is encouraged. Reports should be submitted on DA Form 2028 (Recommended Changes to DA Publications) and forwarded direct to Commanding General, U.S. Army Mobility Equipment Command, ATTN AMSME-MPP, 4300 Goodfellow Blvd., St. Louis, Missouri 63120.

*e.* Report all equipment improvement recommendations as prescribed in TM 38-750.

#### 1-2. Record and Report Forms

*a.* DA Form 2258 (Depreservation Guide for Vehicles and Equipment).

*b.* For other record and report forms applicable to operator, crew, and organizational maintenance, refer to TM 38-750.

Note. Applicable forms, excluding Standard Form 46 (United States Government Motor Vehicles Operator's Identification Card), which is carried by the operator, shall be kept in a canvas bag mounted on equipment.

### Section II. DESCRIPTION AND TABULATED DATA

#### 1-3. Description

The Lubricating and Servicing Unit (figs. 1-1 and 1-2) is a trailer mounted, self-contained gasoline-powered unit equipped to lubricate all types of equipment and components. The unit consists of three storage tanks, three pumps (grease, engine oil and gear oil), five hose reels (two for grease, one for engine oil, one for gear oil and one air service), one transfer pump, a set of hand guns, adapters,

couplings, etc. for specialized lubrication. Compressed air forces the desired lubricant from its storage tank through the reel mounted hose to the component to be lubricated. The speed and pressure of each air powered pump is controlled by a separate air pressure regulator with an individual pressure gage. The piston-type air compressor is driven by a belt and pulley arrangement from the four-cylinder, four-cycle, air cooled gasoline engine. The hose reel bank, consisting of the five hose reels, is

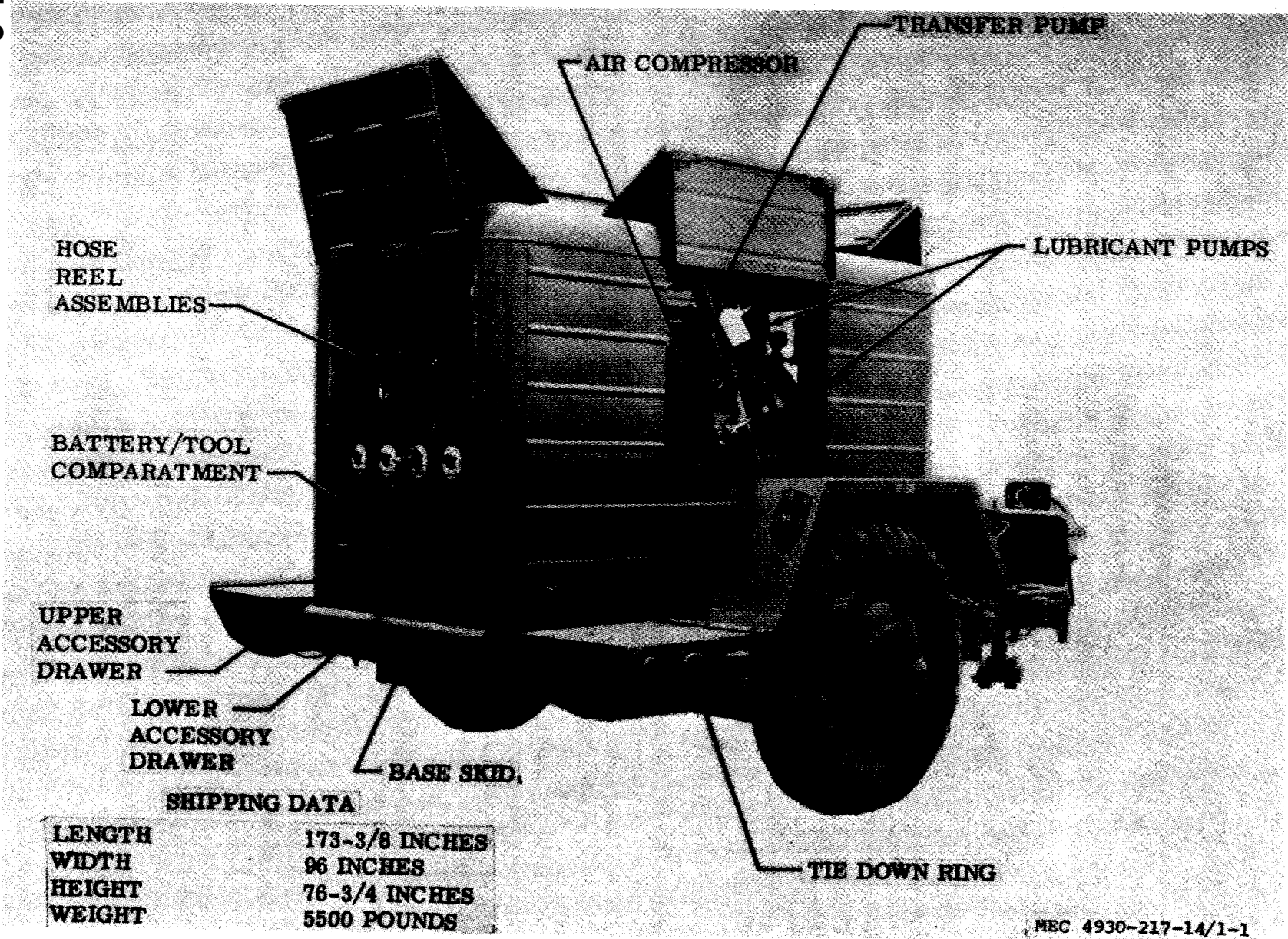

MEC 4930-217-14/1-1

Figure 1-1. Lubricating unit, right, rear, 3/4 view.

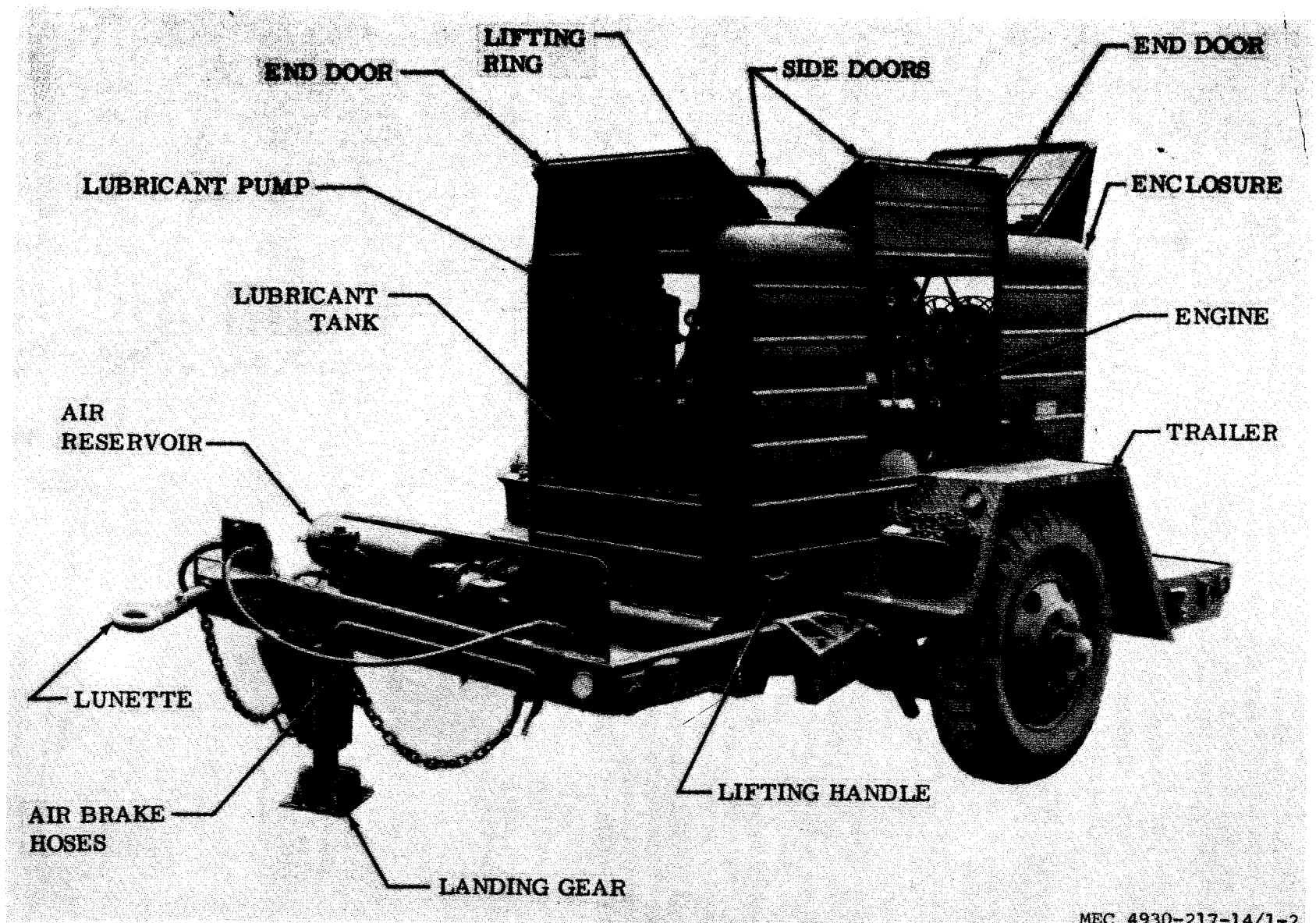

MEC 4930-217-14/1-2

mounted at the rear of the lubricator. Accessory drawers for stowage of specialized lubricating equipment are located directly below the hose reels. An enclosure with doors on each side protects the unit from inclement weather.

#### 1-4. Identification and Tabulated Data

*a. Identification.* The lubricating and servicing unit has five major data and identification plates.

(1) *U.S. Army data plate.* Located on the left side of the enclosure. It gives the description, serial number, manufacturer, model and dimensions.

(2) *Engine data plate.* Located on the engine block. It gives the manufacturer, serial number, and operating characteristics.

(3) *Compressor data plate.* Located on the compressor body; it gives the manufacturer, model and serial number.

(4) *Transportation data plate.* Located on the enclosure next to the U.S. Army Data Plate. It gives the center of gravity, axle load and pintle load in pounds.

(5) *Trailer data plate.* Located on the tongue of the trailer and contains the FSN 2330-697-9002, chassis trailer 2½ ton, Engineering Drawing No. 13212E3626 and manufacturer.

#### *b. Tabulated Data.*

##### (1) *End item.*

Manufacturer.....Elliott Machine Works  
Model.....Eng-8  
FSN.....4930-935-4451

##### (2) *Engine.*

*Note.* Military Standard Engine, refer to TM 5-2805-203-14.

##### (3) *Air compressor.*

Manufacturer.....Worthington Corp.  
Type.....CV  
Drive.....Belt  
Displacement.....23.0 cfm (cubic feet per minute)  
Stroke.....1.625 inch  
Operating pressure.....150-175 psi (pounds per square inch)

(4) *Transfer pump (serial numbers 69-29737 through 69-29942).*

Manufacturer ---Balcrank, Inc.  
Part No. ....43149-1  
Operating pressure .....75-150 psi

(5) *Transfer pump (serial numbers 84-29943 through 84-30304) (serial numbers 86-30305 through 86-31248).*

Manufacturer .....Stewart-Warner  
Part No. ....G330783  
FSN .....4930-910-8375  
Operating pressure .....75-140 psi

##### (6) *Alcohol dispenser.*

Manufacturer .....Balcrank, Inc.  
Model .....5473

##### (7) *Trailer.*

Manufacturer ---Elliott Machine Works  
Part No. ....1069-8  
FSN .....2330-897-9002  
Length .....172 in.  
Width .....96 in.  
Height .....48 in.  
Weight .....2730 Pounds

(8) *Lubricant pumps (serial numbers 69-29737 through 69-29942).*

Manufacturer .....Balcrank, Inc.  
High pressure pump .....43881  
High pressure pump ratio .....50 to 1  
Low pressure pump .....43877  
Low pressure pump ratio .....10 to 1

(9) *Lubricating pumps (serial numbers 84-29943 through 84-30304) (serial numbers 86-30305 through 86-31248).*

Manufacturer .....Stewart-Warner  
High pressure pump .....G330769  
High pressure pump ratio .....40 to 1  
Low pressure pump .....G330768  
Low pressure pump ratio .....12 to 1

##### (10) *Type of lubricants required.*

High pressure pump .....General purpose grease  
Low pressure pump .....Engine and gear oil

##### (11) *Batteries.*

Batteries.....24 volts, negative ground  
Number.....2

##### (12) *Capacities.*

Fuel tank.....10 gallon  
Hydraulic brake system..... $\frac{5}{16}$  quart  
Alcohol dispenser..... $\frac{1}{4}$  quart  
Lubricant storage bins  
Lubricating grease.....175 lb.  
Lubricating gear oil.....27 gallon  
Lubricating oil.....27 gallon

**(13) Dimensions and weight.**

Overall height.....	76 $\frac{1}{2}$ in.
Overall length.....	173 $\frac{1}{2}$ in.
Overall width.....	96 in.
Shipping weight.....	5500 lb.
Shipping cubage.....	758 cu ft.
Center of gravity.....	See data plate

**(14) Wiring diagram.** Refer to figure 1-3 for the unit wiring diagram.

**(15) Lubrication hose diagram.** Refer to figure 1-4 for a lubrication hose diagram.

**(16) Air and hydraulic schematic.** Refer to figure 1-5 for the air-hydraulic diagram.

**1-5. Difference in Models**

This manual covers only the Elliott Machine Works Model ENG-3 Lubricating and Servicing Unit. The known differences exist as follows: Units with serial number range 69-29737 through 69-29942 use pumps, reels and accessories manufactured by Balcrank, Division of Wheelabrator Corporation. Units with serial number range 84-29943 through 84-30304 and 86-30305 through 86-31248 have the same items manufactured by the Stewart Warner Corporation.

*Note.* All units use the Balcrank alcohol dispenser part number 473.



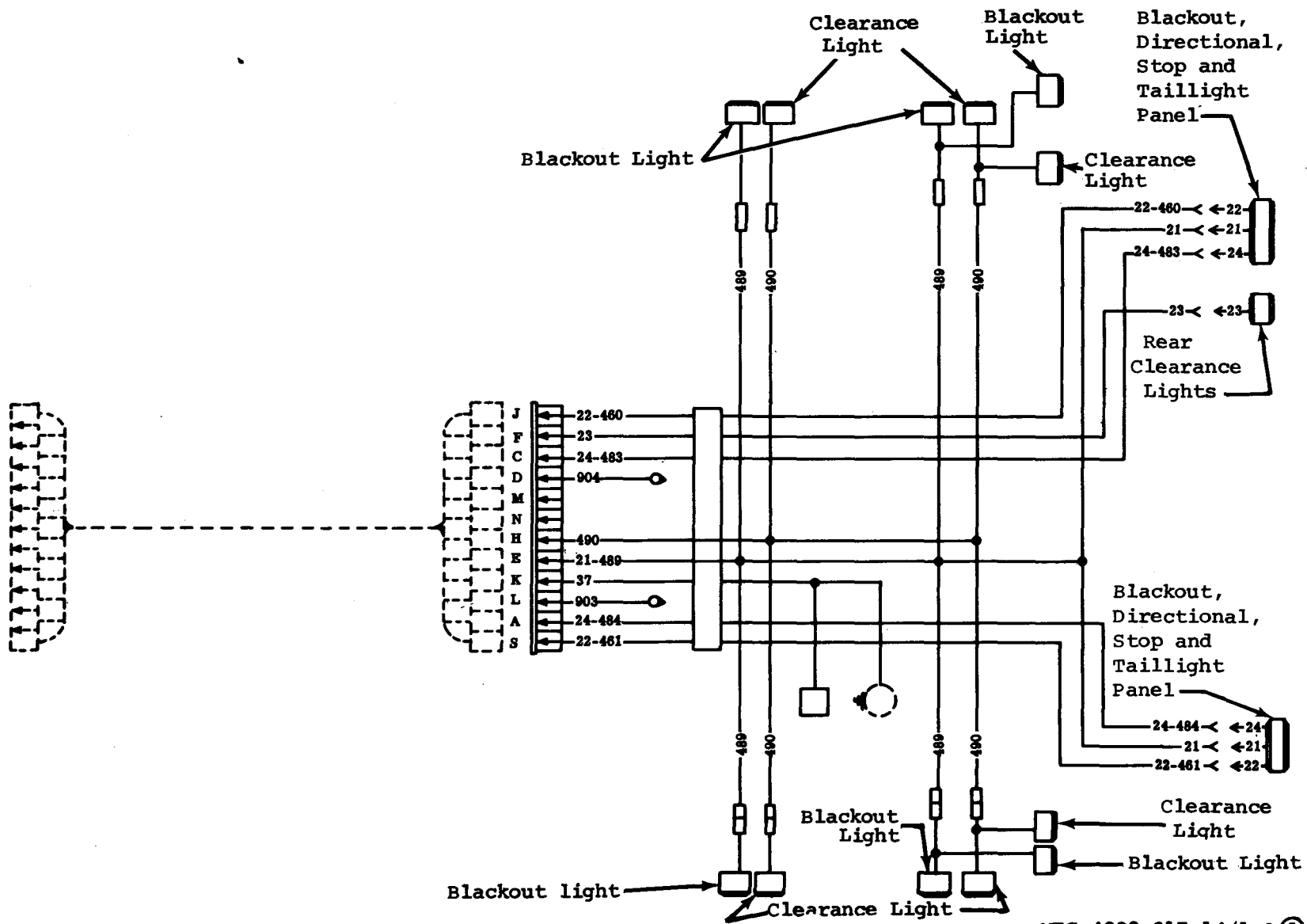

MEC 4930-217-14/1-3 ①

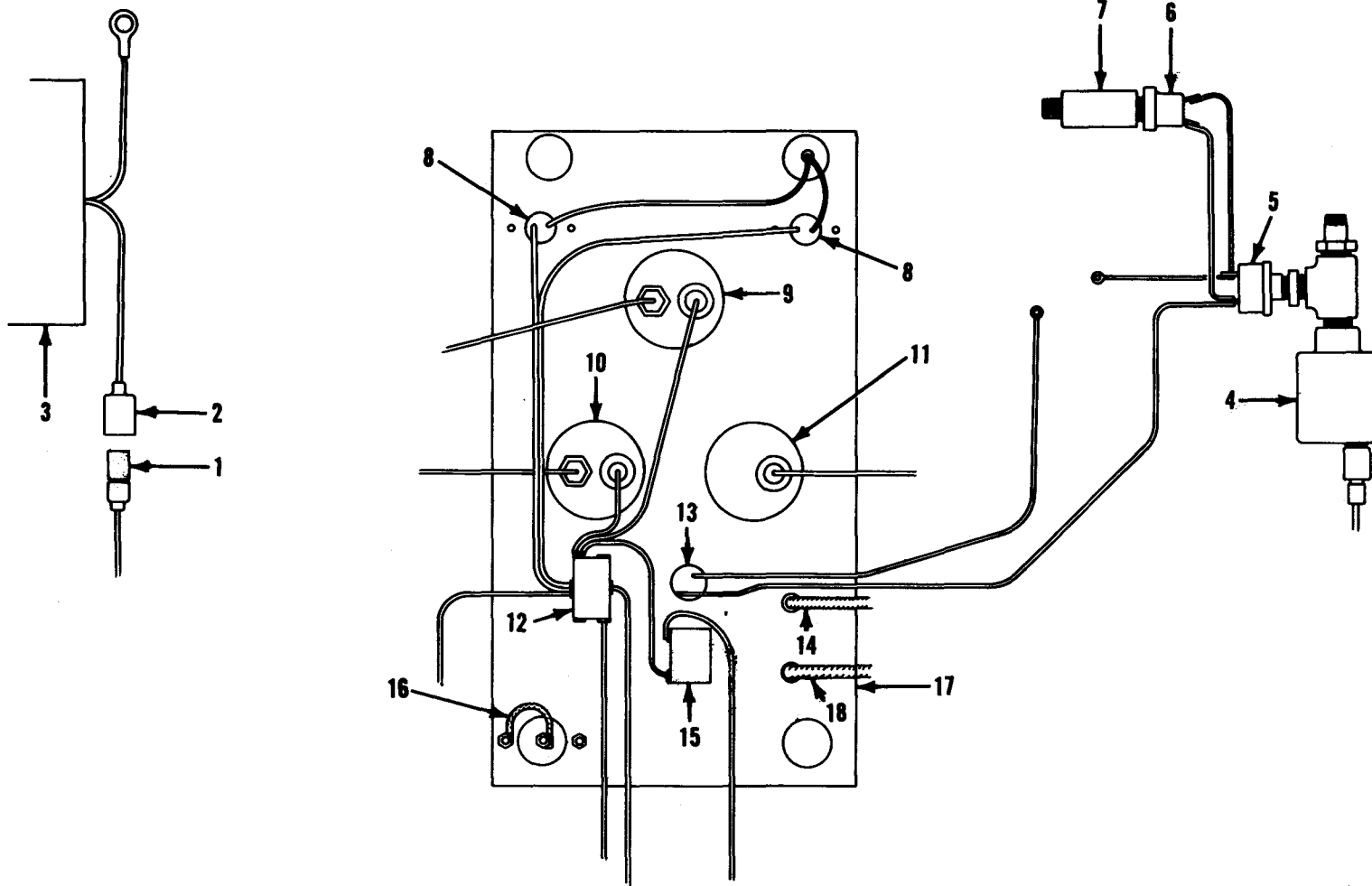

MEC 4930-217-14/1-3 ②

- 1 Lead
- 2 Terminal
- 3 Reel light
- 4 Sender
- 5 Switch
- 6 Switch

- 7 Adapter
- 8 Panel lights
- 9 Gauge
- 10 Gauge
- 11 Ammeter
- 12 Switch

- 13 Switch
- 14 Choke control
- 15 Switch
- 16 Connection
- 17 Control panel
- 18 Throttle control

Figure 1-3 ②—Continued.

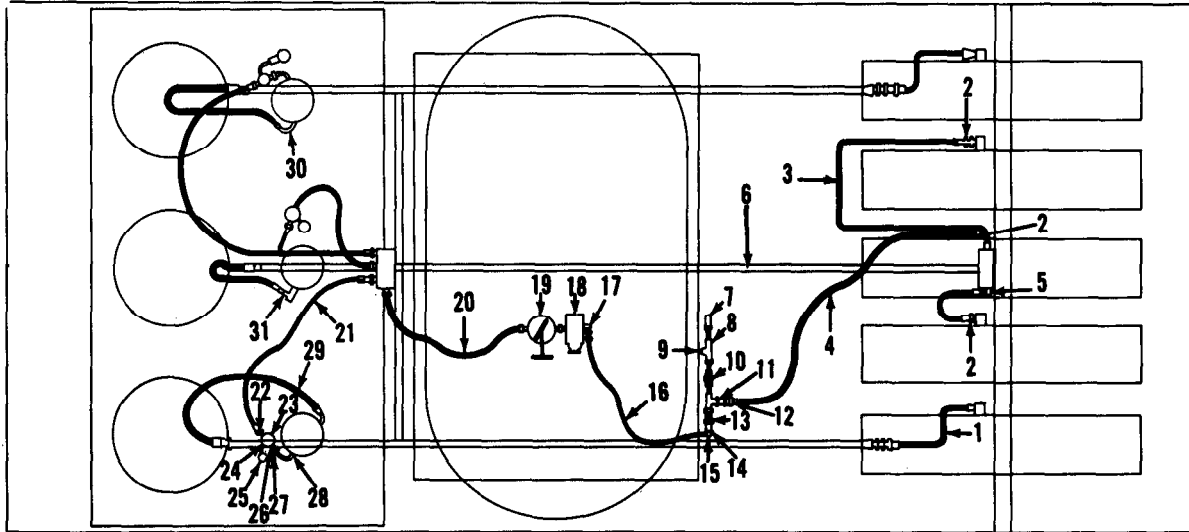

MEC 4930-217-14/1-4

- |           |            |              |            |
|-----------|------------|--------------|------------|
| 1 Hose    | 9 Nipple   | 17 Adapter   | 25 Gage    |
| 2 Adapter | 10 Valve   | 18 Valve     | 26 Nipple  |
| 3 Hose    | 11 Nipple  | 19 Dispenser | 27 Bushing |
| 4 Hose    | 12 Bushing | 20 Hose      | 28 Elbow   |
| 5 Adapter | 13 Bushing | 21 Hose      | 29 Hose    |
| 6 Tubing  | 14 Elbow   | 22 Adapter   | 30 Elbow   |
| 7 Valve   | 15 Nipple  | 23 Regulator | 31 Adapter |
| 8 Tee     | 16 Hose    | 24 Elbow     |            |

Figure 1-4. Lubrication hose diagram.

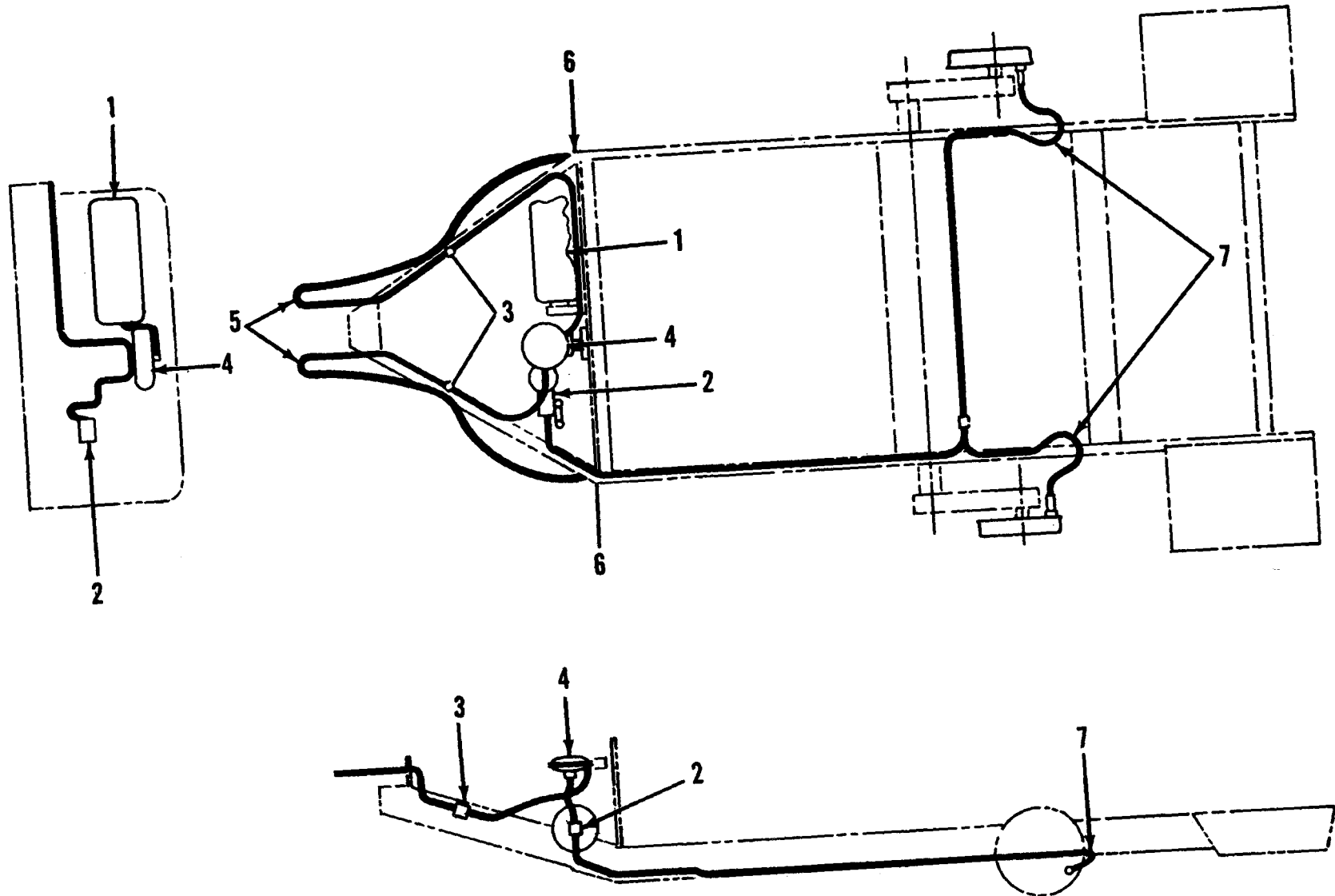

- 1 Reservoir
- 2 Cylinder Assembly
- 3 Air cleaner assembly

- 4 Valve relay emergency breakaway air brake
- 5 Hose and hose assembly, rubber, air and vacuum brake automotive

- 6 Coupling, automotive air brake line
- 7 Hose assembly, rubber, hydraulic brake

Figure 1-5, Air and hydraulic schematic.

## CHAPTER 2

### INSTALLATION AND OPERATING INSTRUCTIONS

---

#### Section I. SERVICE UPON RECEIPT OF EQUIPMENT

##### 2-1. Unloading the Equipment

*a. General.* The operator of the lubricating and servicing unit may assist in unloading the equipment from the common carrier or flatcar. The operator will help remove the tiedown cables and blocking which secure the equipment. Before towing, make certain to align and secure the towing vehicle to the lubricating unit, and install the trailer light coupling and trailer brake connector to the towing vehicle.

*b. Shipment by Tractor.* When lubricating unit is received by trailer, tow it to its destination.

*c. Shipment by Rail.*

(1) *Blocking and Tiedown.* Remove all blocking and tiedown devices securing unit to flatcar as shown in figure 2-1.

(2) *Ramp unloading.* If unit is to be towed from the carrier bed, construct a ramp at the end of the flatcar (fig. 2-2). Be sure to block wheels of flatcar to keep it stationary.

*Note.* Test brakes before approaching the ramp.

(3) *Lifting the equipment.* Attach a suitable lifting device of adequate lifting capacity (3 tons or more) to the unit as shown on figure 2-1 and lift from the flatcar or trailer.

**Warning: Do not allow the lubrication unit to swing back and forth when it is suspended in the air. Failure to observe this warning can result in damage to the equipment and severe injury or death to personnel.**

##### 2-2. Unpacking the Equipment

Prior to inspection and operation, depreserve the lubricating and servicing unit as outlined on DA form 2268 (Depreservation Guide for

Vehicles and Equipment) which will be found near the operator's controls.

##### 2-3. Inspection and Servicing Equipment

*a.* Perform the daily preventive maintenance services paragraph 3-6.

*b.* Make a complete visual inspection of the lubricating and servicing unit for loss, damage or pilferage of components.

*c.* Inspect for dented or punctured enclosure and doors.

*d.* Inspect all components for proper mounting.

*e.* Make sure all equipment shipped with the unit is undamaged and in serviceable condition.

*f.* Remove caps from cells of the battery and fill with electrolyte to a level of one-fourth inch below the filler holes. Refer to TM 9-6140-200-15 for complete servicing of wet batteries.

**Warning: When servicing battery, do not smoke or use an open flame in the vicinity. Batteries generate hydrogen, a highly explosive gas.**

*g.* Lubricate the unit in accordance with LO 5-4930-217-12.

*h.* Cold weather servicing for the air cooled engine is not required.

##### 2-4. Installation of Separately Packed Components

The batteries for the unit may be shipped dry-charged. The electrolyte for filling the battery cells is shipped in separate containers. Fill the batteries with electrolyte until the level is one-fourth inch below the filler holes. When the

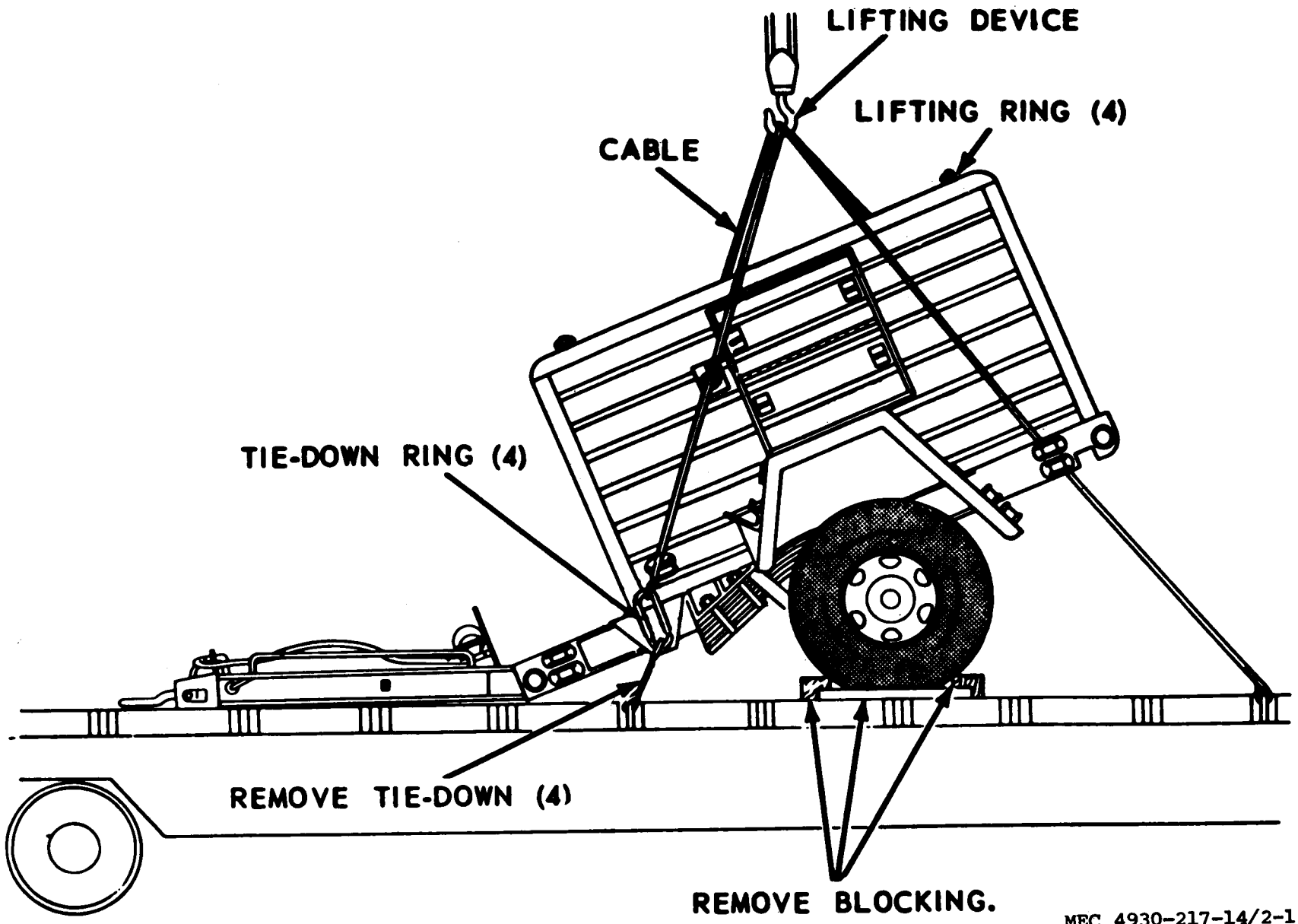
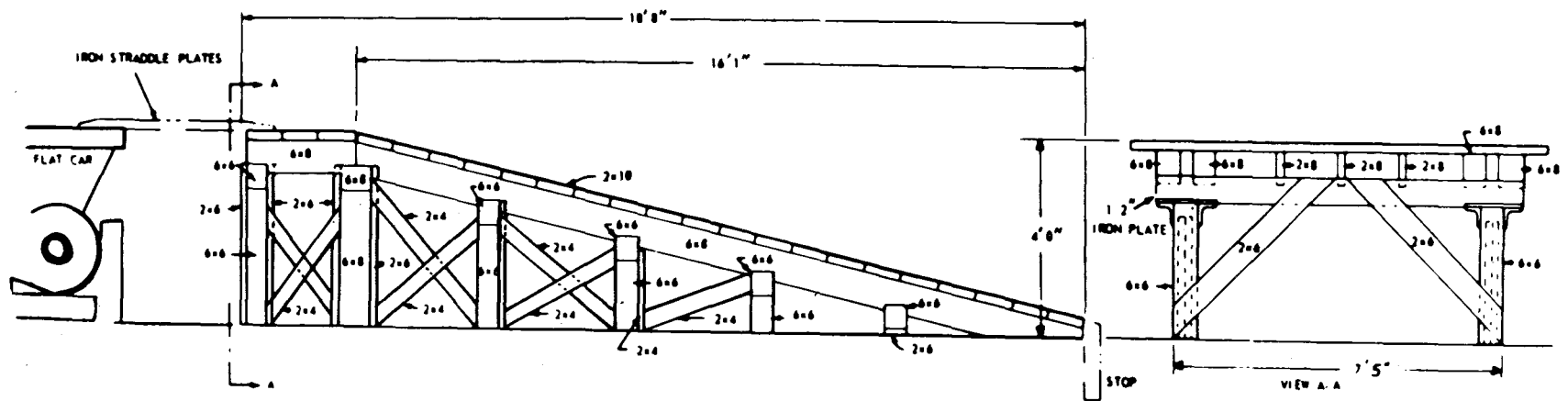
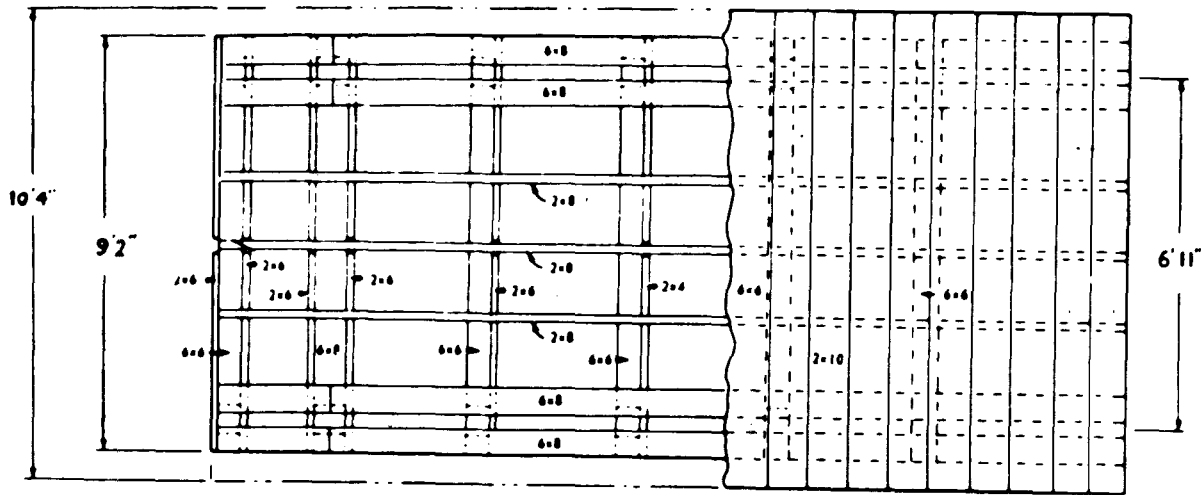

Figure 2-1. Unloading lubricating unit.



MEC 4930-217-14/2-2

Figure 2-2. Loading ramp construction.

batteries are filled, place them in the battery box and connect the batteries. Use the negative battery terminal for ground connection.

**Warning:** Clean up any spilled electrolyte with water. Keep the electrolyte off the skin to prevent personal injury.

## 2-5. Installation or Setting Up Instructions

*a. General.* The lubrication and servicing unit is a self-contained unit and requires no special mounting base. Locate the unit where it will be level at all times and will receive a supply of clean, dry air. Air filled with dust will clog the air cleaners. If the unit is placed in a confined area, and air circulation is restricted, it could heat up and affect the operation. Locate the equipment so that the hose reels and lubricant pumps are accessible. Block wheels so unit will not roll.

*b. Batteries.*

(1) Service the batteries as instructed in paragraph 2-4.

(2) To inspect and adjust the battery clamp, proceed as follows

(a) Loosen locknut and place clamp handle up or at right angle to battery terminal.

(b) Remove clamps from battery terminals and inspect for loose or corroded condition. Remove corrosion and coat battery terminals and clamps with grease.

(c) Install clamps on battery terminals. Tighten bushing nut to a friction-fit, between lug and battery post.

(d) Tighten locknut and push handle down until parallel with clamp.

*c. Enclosure.* Open enclosure doors for adequate air circulation.

**Warning:** Do not operate the lubricating and servicing unit in an enclosed area unless the exhaust gases are piped to the outside. Inhalation of exhaust fumes will result in serious illness or death.

*d. Compressor Air Cleaner.* Remove the protection wrapper from the compressor air cleaner.

## Section II. MOVEMENT TO A NEW WORKSITE

### 2-6. Dismantling for Movement

*a. General.*

(1) Release all air from air storage tank by opening air tank drain valve (44, fig. 2-3).

(2) Disconnect battery cables from the batteries.

(3) Lock the hose reels by applying the reel brakes to each of the reels and properly stow all tools and accessories. Close lubrication tank covers.

(4) The lubricating and servicing unit is self-contained and requires no disassembly for movement.

(5) Disconnect and drain lines and hoses.

(6) Close and fasten all enclosure doors.

(7) The unit can be carried or towed to a new worksite.

*b. Transportation to Worksite.*

(1) Attach a suitable towing vehicle to the trailer; connect the trailer air brakes, safety chains, and electrical systems. Check condition of systems for proper operation before movement.

(2) Retract the landing gear. Secure in the travel position. Remove the wheel chocks and stow on fender mounting bracket.

### 2-7. Reinstallation after Movement

Procedure required for reinstallation of the equipment after movement to a new location is identical to those procedures required for installation or setting up new equipment (para 2-5).

## Section III. CONTROLS AND INSTRUMENTS

### 2-8. General

This section describes, locates, and furnishes

the operator, crew or organizational maintenance personnel sufficient information about the various controls and instruments for



proper operation of the lubricating and servicing unit.

## 2-9. Controls and Instruments

The purpose of the controls and instruments and the normal and maximum reading of the instruments are illustrated in figure 2-3 and described in the following paragraphs.

*a. Ignition Switch.* The ignition switch (16, fig. 2-3) is an ON-OFF switch that controls the engine magneto circuit.

*b. Start Switch.* A pushbutton type start switch (14, fig. 2-3) is located in the lower left-hand corner of the control panel and is utilized to operate the starter motor.

*c. Choke Control.* The choke control (10) is located on the engine control panel and enables the operator to enrich the fuel mixture for starting purposes. Pull out the choke control to enrich the fuel-air mixture in the carburetor. When the choke control knob is pulled out as far as it will go, the carburetor choke is fully closed. When the engine starts the choke control must be pushed back in to open the carburetor choke. If this is not done, the engine will lack power and could stop by "flooding out".

*d. Oil Pressure Gage.* The oil pressure gage (13) is a dial-type instrument which indicates oil pressure in pounds per square inch. Under normal operating conditions, the oil pressure gage should indicate a reading of between 20 and 35 psi after the engine is thoroughly warmed.

*e. Battery-Generator Indicator gage.* The Battery-generator gage (12) is located on the control panel. It is a dial-type instrument which shows the condition of the battery. If the indicator is on the red on the left, the battery is dead; on the yellow, the battery is partially charged; on the green, the battery is fully charged and on the red on the right, the battery is overcharged.

*f. Panel Lights.* Two panel lights (7) are located on the top of the control panel and are operated by individual switches on the bottom of the lights.

*g. Throttle Control.* The throttle control (15) is located on the control panel and pro-

vides the adjustment for controlling engine speed.

*h. Fuel Gage.* The fuel gauge (9) indicates the amount of fuel in the fuel tank. The gage ranges from "empty" to "full".

*i. Bypass Switch.* The bypass switch (11) is located above the engine ignition switch on the control panel. Its function is to bypass the low oil pressure safety switch during the starting procedure so as to permit engine starting.

*j. Alcohol Dispenser.* The alcohol dispenser (6) is bracket-mounted to the engine side of the lubricating and servicing unit, and is used to prevent freezing of condensed air in the air lines and pumps. A needle valve controls the rate of alcohol flow from the dispenser.

*k. Air Valve.* The air gate valve (47) is located at the air receiver on the engine side of the lubricating unit. The valve releases air from the air receiver, through the air hose reel, to the master air valve. To release air from the air receiver, turn the handle counterclockwise.

*l. Reel Brakes.* A hand-operated reel brake (45, fig. 2-3) is mounted on the hub of each hose reel to permit locking of the hose reels at any position during operation or after operation. The reel brake is a lever-type control.

*m. Engine Exhaust Diverter Handle.* The two engine exhaust diverter handles (22) are used to either direct heat from the engine exhaust into the hot air reservoir, or direct exhaust gases through a hose to the atmosphere outside the unit.

*n. Air Pressure Regulators.* Individual air pressure regulators (24) for the three lubricating pumps are mounted on the air line between the air receiver and the lubricant pumps. Air pressure to the lubricating pumps is controlled by the air regulators. The exact air pressure to operate the pumps must be determined by the operator, based upon volume or delivery rate required. To increase air pressure to the pumps, turn the regulator handle clockwise.

*o. Air Pressure Gage.* Air pressure gage (25) is mounted on each of the three air regulators. Each gage registers the amount of air

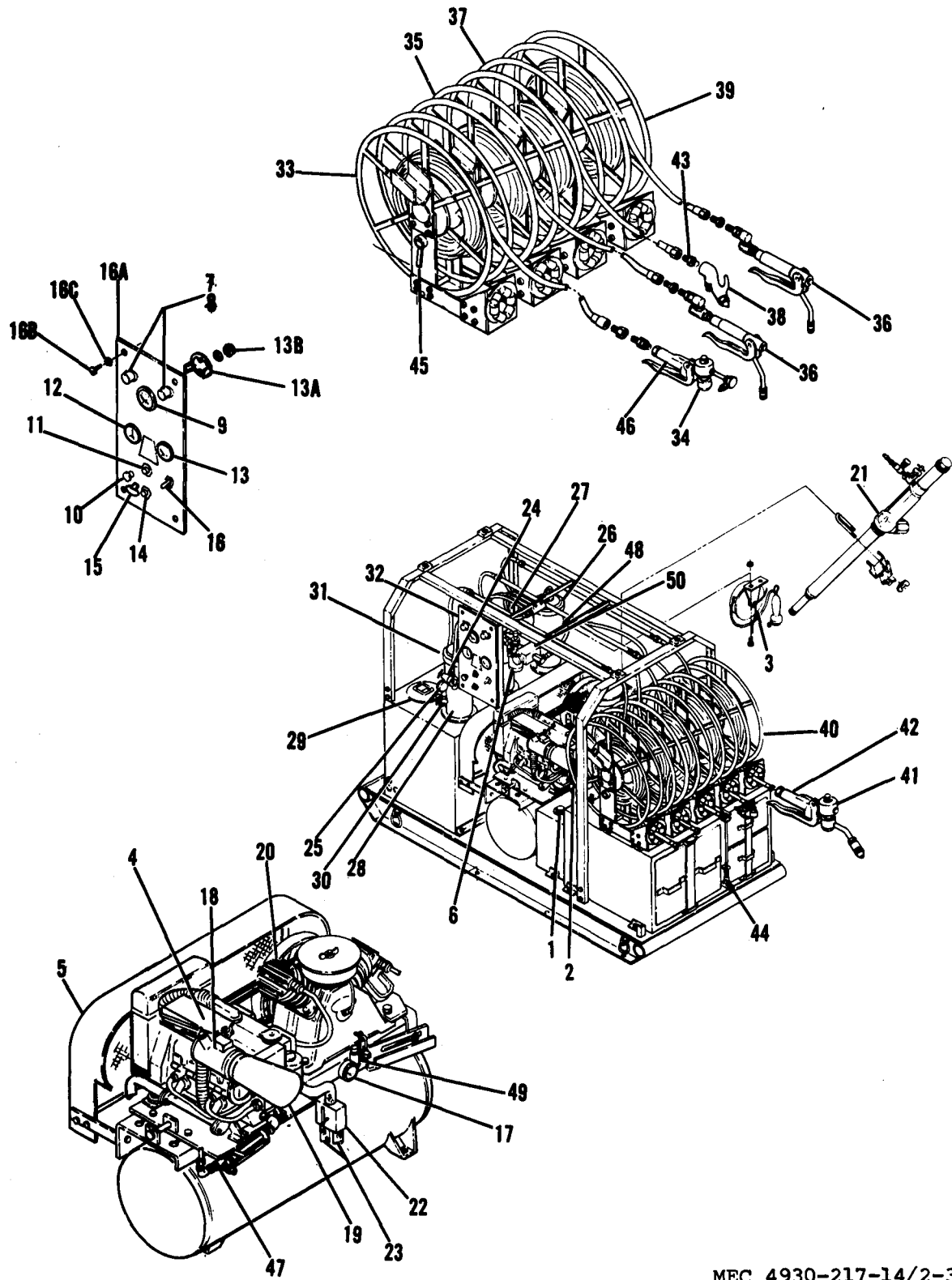

MEC 4930-217-14/2-3

Figure 2-3. Operating controls, instruments and major component location.

1	Fuel tank fill	24	Air pressure regulator (3)
2	Portable lubricator	25	Air pressure gage (3)
3	Trouble light reel	26	Engine oil pump
4	Engine	27	Grease pump
5	Belt guard	28	Gear oil pump
6	Alcohol dispenser	29	Gear oil cover
7	Panel light (2)	30	Circulating valve
8	Incandescent lamp (2)	31	Grease fill cover
9	Fuel gage	32	Engine lubricant fill cover
10	Choke control	33	Gear lubricant hose reel
11	Bypass switch	34	Pintmeter
12	Battery-generator indicator	35	Grease hose reel
13	Oil pressure gage	36	Control valve (2)
13A	Retainer bracket (2)	37	Air hose reel
13B	Retainer nut	38	Pneumatic gun
14	Start switch	39	Grease hose reel
15	Throttle control	40	Engine oil hose reel
16	Ignition switch	41	Quartmeter
16A	Control panel	42	Quartmeter control valve
16B	Screw	43	Air line coupler
16C	Star washer	44	Air tank drain valve
17	Pressure gage	45	Hose reel brake (5)
18	Generator	46	Pintmeter control valve
19	Generator belt guard	47	Air gate valve
20	Air compressor	48	Condensate valve
21	Transfer pump	49	Air line pressure relief valve
22	Exhaust diverter (2)	50	Master air valve
23	Exhaust hoses		

Figure 2-3. Continued.

pressure to its respective pump and is graduated to indicate from 0 to 200 psi.

*p. Condensate Valves.* A manually operated condensate valve (48) is mounted on the side of each pump, and is used to discharge accumulated moisture from the pump air motor. Turn the valve "handle counterclockwise to dispel moisture.

*q. Circulating Valve.* A circulating valve (30) is mounted on the lower housing of each pump, and permits the bypassing and circulating of lubricants with the pump, returning directly into the lubricant compartment. To open the circulating valve, turn the valve handle counterclockwise two full turns.

*r. Control Valve.* A control valve (36) is attached to each grease line. Depress the trigger on the control valve to dispense grease and release the trigger to halt flow.

*s. Meters.* A pintmeter (34) is attached to the gear oil hydraulic line control valve (46). A quartmeter (41) is attached to engine oil hydraulic line control valve (42). Depress the trigger on each control valve to dispense the lubricants and release the trigger to halt lubricant flow. Amount dispensed is registered on respective meter.

*t. Air Line Coupler.* The air line coupler (43) on the air reel end is used to supply compressed air to the various air-operated accessories.

*u. Air Tank Drain Valve.* A manually operated air tank drain valve (44) is mounted on the accessory drawer frame and is directly connected to the air receiver to facilitate draining air and moisture from the air receiver.

*v. Air Receiver Pressure Gage.* The air receiver pressure gage (17) is located on the air pressure tank. The gage is graduated from 0 to 300 psi and should show a pressure of 150 to 175 psi for proper operation of the equipment.

*w. Air Line Pressure Relief Valve.* The air line pressure relief valve (49) is located at the air receiver on the right side of the lubricating unit. The relief valve releases air pressure in the air receiver when it exceeds 200 psi. When this valve opens, the pressure on gage (17) will drop.

*x. Master Air Valve.* The master control valve (22, fig. 3-8) is located next to the alcohol dispenser and is operated by a push-pull plunger. The master control valve allows air to be directed through the alcohol dispenser to

the lube pumps. To operate the master control valve, pull the plunger out to release the air to the lube pumps and push the plunger in to stop the air.

*y. Pressure Relief Valve.* The pressure re-

lief valve (fig. 7-4) is located on the hose reel side of the compressor and unloads the compressor when the tank pressure has reached 175 psi, and allows the compressor to resume when the pressure has dropped to 145 psi.

## Section IV. OPERATION OF EQUIPMENT

### 2-10. General

*a.* The instructions in this section are published for the information and guidance of the personnel responsible for operation of the lubricating and servicing unit.

*b.* The operator must know how to perform every operation of which the lubricating and servicing unit is capable. This section gives instructions on starting and stopping the lubricating and servicing unit, and on coordinating the basic motions to perform the specific tasks for which the equipment is designed. Since nearly every job presents a different problem, the operator may have to vary given procedures to fit the individual job.

*c.* The engine is operated at a speed of 3,200 rpm, under load.

### 2-11. Starting

*a. Preparation for Starting.* Perform the necessary daily preventive maintenance services "paragraph 3-6.

*b. Electric Starting of Engine.*

(1) Push the engine exhaust diverter handle (22, fig. 2-3) into position to direct the engine exhaust gases to the atmosphere outside the unit.

(2) Pull out the choke control (10).

(3) Open the throttle (15) about  $\frac{3}{4}$  inch.

(4) Place the ignition switch (16) to ON and depress and hold down the bypass switch (11).

(5) Push start switch (14).

(6) When engine starts, release start switch (14).

(7) When oil pressure gage (13) exceeds 20 psig, release the bypass switch (11).

(8) Throttle (15) should be pulled all the way out for normal operation.

*Note.* Engine rpm under load should be 8200 rpm. See TM 5-2805-203-14 for engine rpm adjusting instructions.

(9) Push in choke control after engine starts.

*c. Manual Starting of Engine.*

(1) Perform (1) through (4) as previously stated. Have another person perform (2) through (4) below.

(2) Wind the starting rope in a clockwise direction around the engine flywheel sheave leaving about 6 inches free at the handle end.

(3) Give a fast strong steady pull the full length of the rope. If the engine does not start at the first attempt, increase choking and crank again.

(4) After the engine starts, gradually push in the choke control until the engine runs smoothly, increase throttle, if necessary, and release bypass switch.

### 2-12. Stopping

*a. Normal Stopping.*

(1) Close the throttle (15, fig. 2-3).

(2) Close the master air valve (50).

(3) Open the air tank drain valve (44).

(4) Place the ignition switch to OFF.

(5) Perform the necessary daily preventive maintenance services, (para 3-6).

*b. Emergency Stopping.* Turn the ignition switch (16) to OFF position.

### 2-13. Operating under Usual Conditions

*a.* Start the equipment as indicated in paragraph 2-11.

*b.* Refer to the following paragraphs 2-14 through 2-17 for complete information on operation of the lubricating and servicing unit.

## 2-14. Filling Lubricant Tanks

a. Close the master air valve (50, fig. 2-3) at the alcohol dispenser.

b. Air pressure in the tank will automatically build up to 175 pounds. This pressure is preset to cut out at 175 pounds pressure and cut in at 146 pounds pressure.

c. Allow pressure to build until the air receiver pressure gage (17) shows a reading of between 150 and 175 pounds air pressure.

d. Remove the transfer pump (21) from its mounting and install in drum of lubricant to be dispensed. Heavy grease cannot be pumped; pack manually.

e. Remove the transfer pump hose assembly (1, fig. 2-4) from the toolbox assembly and install on the transfer pump assembly.

f. Pull out the air line coupler (43, fig. 2-3) and attach it to the quick air coupler (2, fig. 2-4) on the transfer pump.

g. Open the fill cover (29 or 32, fig. 2-3) and insert the transfer hose into the tank to be filled.

h. Open the master air valve (50).

i. Open the air valve (3, fig. 2-4) on the transfer pump to the required volume.

j. When the hopper is filled, close master air valve (50, fig. 2-3).

Note. Always keep lubricant containers three-quarters full.

k. Clean and store the transfer pump and hose in their respective positions.

l. Open the air tank drain valve (44) to drain moisture and air pressure from the air tank.

## 2-15. Preparing Lubricant Pumps for Operation

a. Fill lubricant tanks, (para 2-14 a through c).

b. Open the master air valve (50, fig. 2-3) and close air tank drain valve (44).

c. Turn the air regulator handles (24) clockwise, until set at the desired air pressure, as registered on the air gauge (25).

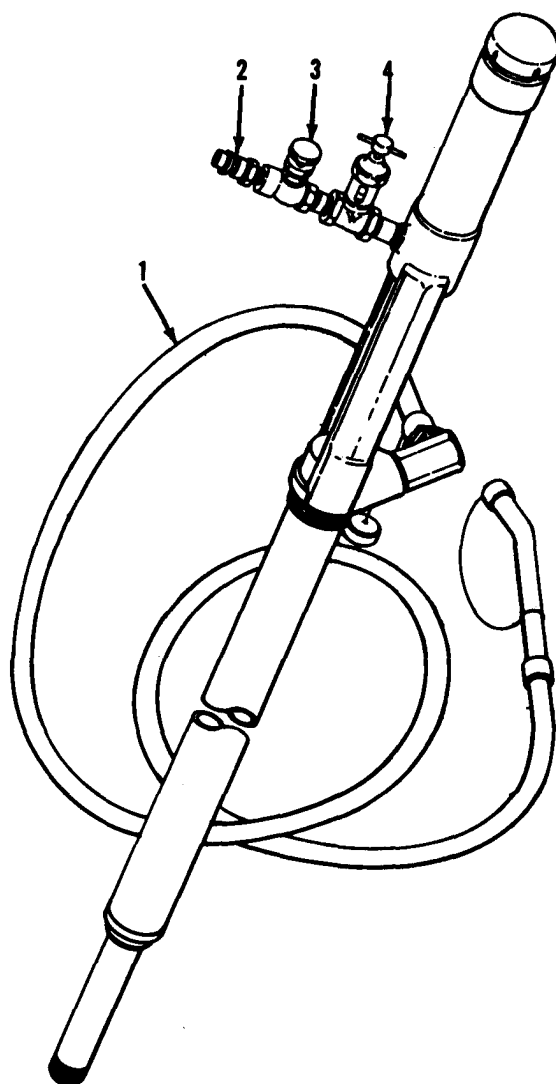

MEC 4930-217-14/2-4

1 Hose  
2 Quick air coupler  
3 Air valve  
4 Oiler assembly

Figure 2-4. Transfer pump operation.

d. Air pressure to each pump must be adjusted at the individual pump. Turn the air regulator handle clockwise to increase air pressure, and counterclockwise to decrease air pressure. The exact air pressure to operate pumps must be based on delivery rate required and viscosity.

e. Open the circulating valve (80) of each pump by turning the valve handle two full turns counterclockwise.

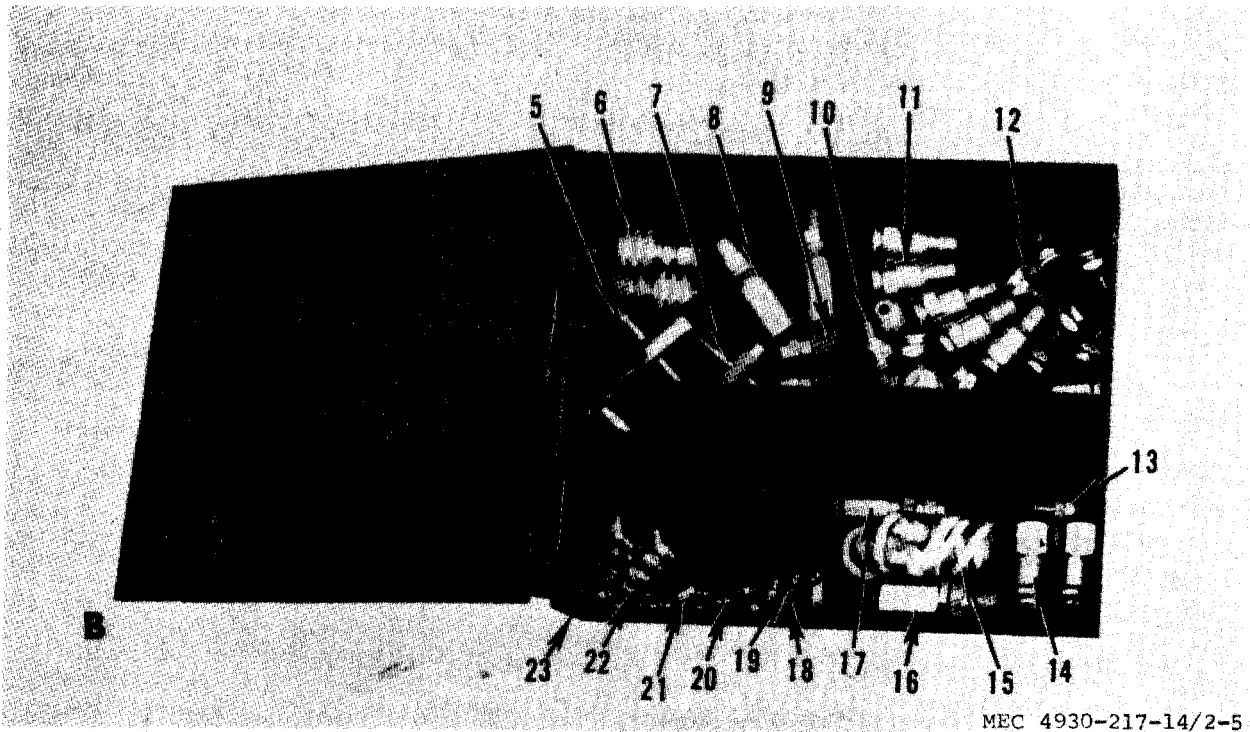
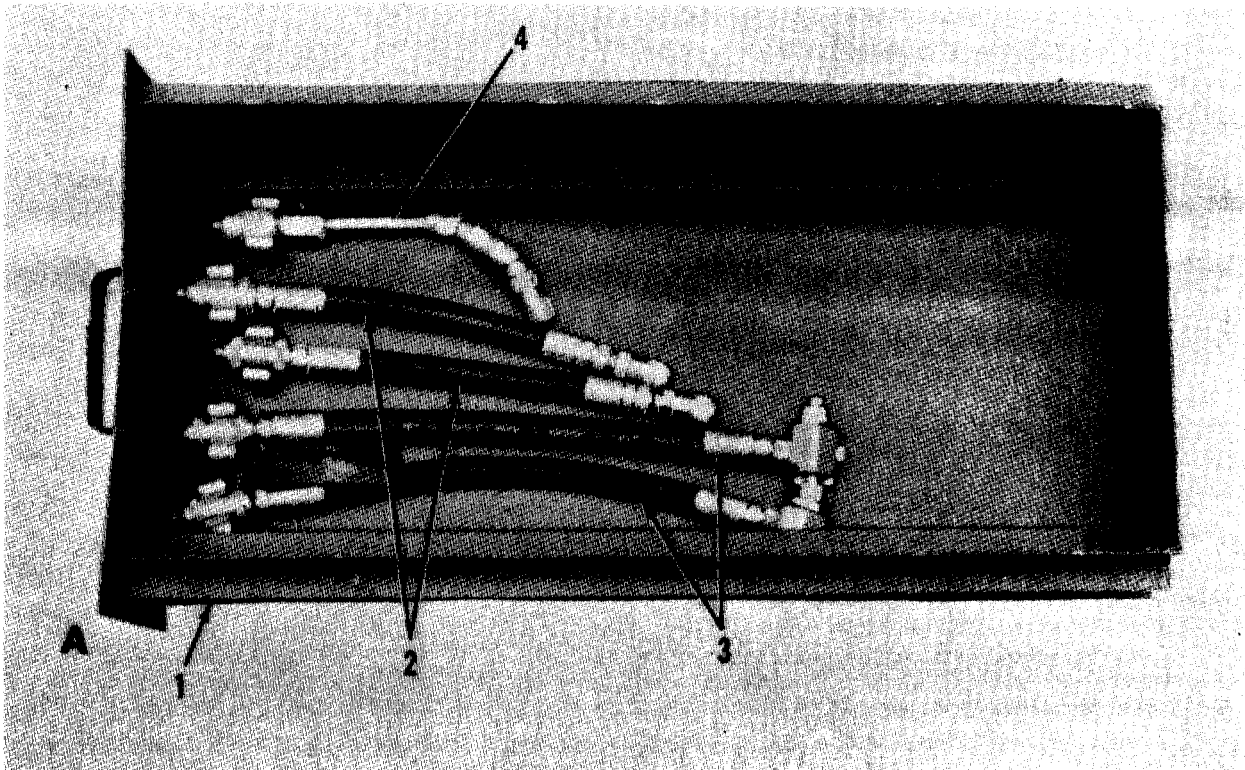

MEC 4930-217-14/2-5

Figure 2-5. Lower drawer assembly.

1 Lower drawer  
 2 Flexible extension adapter (2)  
 3 Flexible extension adapter (2)  
 4 Extension adapter  
 5 Easy out tool  
 6 Coupler (2)  
 7 Easy out tool  
 8 Hose coupling (2)  
 9 Coupler (2)  
 10 Button head fitting (6)  
 11 Giant button head fitting (6)  
 12 Button head fitting (6)

13 Fitting  
 14 Swivel  
 15 Engine start rope  
 16 Straight Swivel  
 17 Hose coupling  
 18 Pipe plug (2)  
 19 Hydraulic fitting (6)  
 20 Hydraulic fitting (6)  
 21 Hydraulic fitting (6)  
 22 Hydraulic fitting (6)  
 23 Tray assembly

Figure 2-5.—Continued.

f. After charging pump with lubricant, close each circulating valve by turning them all the way clockwise.

g. Open the hose reel access door, release the reel brake (45, fig. 2-3) of the lubricant reel to be used. Unhook the control valve(s) (36, 42, 46) from the bracket, and pull the hose from the reel.

h. Squeeze open the control valve (36, 42 or 46) by depressing the trigger and the pump will automatically start filling the line and forcing lubricant through the control valve nozzle or adapter.

i. Allow lubricant to flow until the line has been purged of air, and no aerated lubricant is dispensed.

j. Repeat this operation on the other three lubricant hoses. The lubricating unit is now ready to dispense lubricant.

## 2-16. Dispensing Lubricants

### a. Dispensing General Purpose Grease.

(1) Prepare the grease pump (27, fig. 2-3) for operation (para 2-15).

(2) Release the reel brake (45, fig. 2-3) from one of the general purpose grease reels (35) or (39) and pull out the required length of hose.

(3) Attach the proper adapter from the lower drawer assembly (fig. 2-5), or upper drawer assembly (fig. 2-6).

(4) Clean each grease fitting of the part being lubricated. Attach the adapter to it and squeeze the trigger.

(5) When all the old grease has been forced out of the part being lubricated, release the trigger. Disconnect the adapter and go on to the next fitting.

(6) When lubricating is complete, disconnect the adapter from the control valve. Wipe it clean and return it to the accessory drawer. Rewind the hose on the reel and replace the control valves on the bracket. Secure the reel brake.

### b. Dispensing Gear Oil.

(1) Prepare the gear oil pump (28, fig. 2-3) for operation (para 2-15).

(2) Release the reel brake (45, fig. 2-3) and pull out the required length of hose. Set meter pointer on the pintmeter (34) to "0".

**Caution: Do not try to set the pointer beyond the "0" position.**

(3) Clean around the filler plug opening of the unit to be filled. Remove the filler cap or plug. Insert the valve nozzle into the filler opening and add the proper amount of oil.

(4) Clean and replace the filler plug or cap.

(5) Rewind the hose, set the reel brake and hang the valve on the bracket.

### c. Dispensing Engine Oil.

(1) Prepare the engine oil pump (26, fig. 2-3) for operation, paragraph 2-15.

(2) Release the reel brake, remove the valve from the bracket, and pull out the desired amount of hose.

(3) Set the meterpointer on the quart-meter (41) to "0".

**Caution: Do not try to set the pointer beyond the "0" position.**

(4) Clean around the filler plug. Remove filler plug, insert nozzle, and fill reservoir to proper level.

(5) Clean and replace plug. Rewind hose, set reel brake and return valve to bracket.

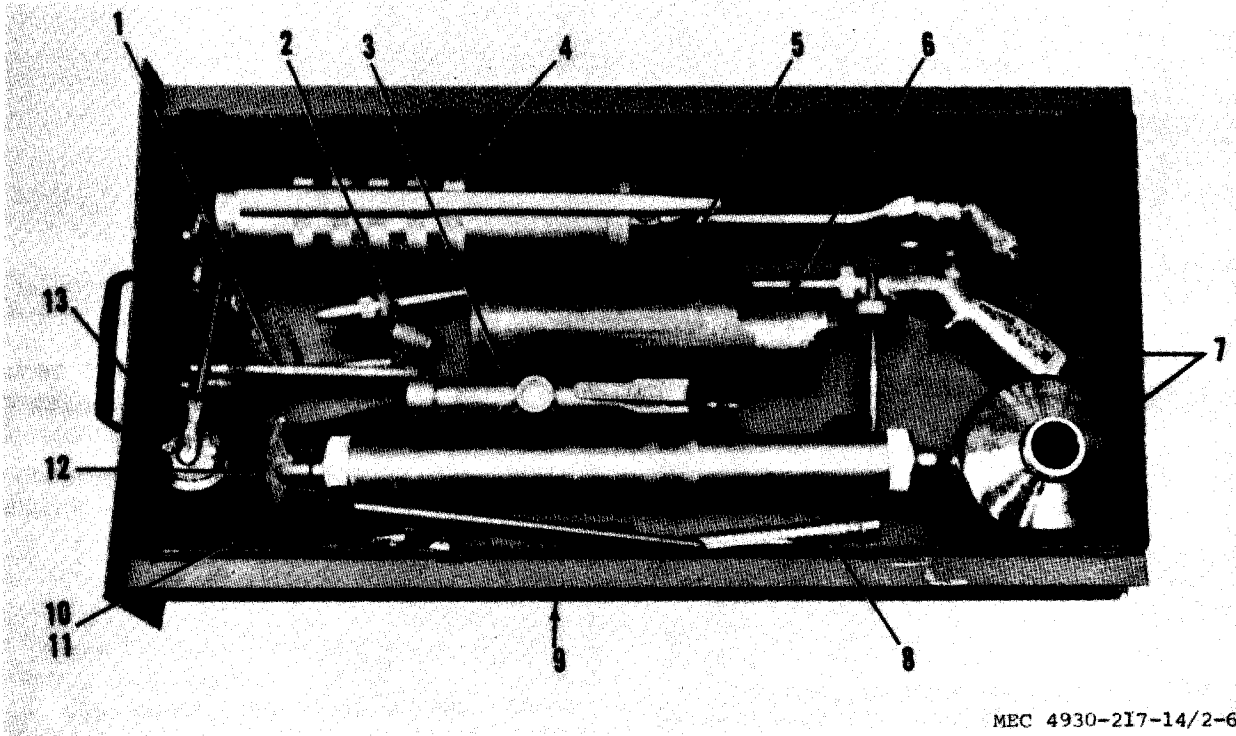

MEC 4930-2I7-14/2-6

- |                               |                          |                         |
|-------------------------------|--------------------------|-------------------------|
| 1 Extension                   | 6 Pump extension         | 10 Hack saw frame       |
| 2 Adapter                     | 7 Air operated spray gun | 11 Hack saw blade       |
| 3 Air chuck and pressure gage | 8 Flexible nozzle        | 12 Suction gun assembly |
| 4 Grease gun assembly         | 9 Upper drawer           | 13 Pump feed oiler      |
| 5 Pump extension              |                          |                         |

Figure 2-6. Upper drawer assembly.

*d. Use of Air Chuck.*

(1) Remove the air chuck and pressure gage from the lower drawer assembly.

(2) Attach the air pressure gage and air chuck to the air line coupler (43, fig. 2-3).

(8) Press the air chuck down firmly on the tire valve and depress valve lever to force air into the inner tube. When the proper pressure has been reached, release lever and lift the air chuck off.

(4) After air service operations have been performed, rewind the air reel hose on reel (87), disconnect the air pressure gauge and air chuck from the air line coupler.

(5) Lock the reel brake and replace the air chuck and pressure gage in the upper drawer assembly.

**Warning:** When inflating tires, stand to one side of the tire, not in front of it. Serious injury or death could result if the tire blows off the rim.

## 2-17. Shutdown Procedures

a. With the pumps operating, open the condensate valve (48, fig. 2-3) by turning the valve lever in a counterclockwise direction. Exhausting air will carry accumulated moisture from it.

b. Stop the engine.

c. Close the master air valve (50).

d. Open the air tank drain valve (44) to drain moisture from the compressor air receiver.

## 2-18. Operation in Extreme Cold

a. *General.* Operating the lubricating and servicing unit in extremely cold temperatures presents special problems. Lubrication, fuel, oil, electrical and compressed air systems, and care of lubricants are all affected by cold weather operation.



*b. Care of Lubricants.* Keep lubricants in tightly closed containers and, if possible, in a protected place to insure ease of handling. Remove all snow and ice from the containers before opening them to transfer lubricants to lubricant tanks or to guns.

*c. Special Equipment.* The unit is equipped with an alcohol dispenser (6, fig. 2-3) for cold weather operation, and a heat exhaust diverter (22). The alcohol dispenser prevents freezing of condensate in air lines. The exhaust diverter uses heat from the exhaust to warm lubricant containers.

*d. Lubrication.* During the cold weather, lubricants that are too heavy will make the vehicle hard to start and difficult to operate. This will also cause rapid wear of the moving parts.

*e. Electrical System.* The large surges of electrical current required to start a cold engine demand good electrical contacts. Inspect, clean, and tighten all connections, especially battery terminals.

*f. Fuel System.* In cold weather, condensation of moisture in the air will cause water to accumulate on tools, in drums and containers. This water will freeze and form ice crystals, which clog fuel lines and carburetor jets unless the following precautions are taken.

(1) Use filter paper or other approved strainer when filling the fuel tank or when transferring fuel from one container to the other.

(2) Remove snow or ice from the fuel tank filler cap and dispensing equipment before filling the fuel tank.

(3) Keep the filler cap tightened properly to keep moisture and dirt from the tank.

(4) After filling or moving a fuel container, allow the fuel to settle before filling the tank.

(5) If possible, keep the fuel tank full when operating in extreme cold weather. This will prevent condensation of moisture inside the tank.

*g. Compressed Air System.* Drain accumulated moisture from the compressed air reservoir as often as necessary. The air reservoir is

equipped with an air tank drain valve (44, fig. 2-3). When the air tank drain valve is rotated counterclockwise, the water which has collected to the bottom of the tank will run out.

*h. Batteries.* The batteries installed in the lubricating unit will give satisfactory service in extreme low temperatures if care is taken to keep the batteries fully charged. If the lubricating unit is to remain idle, for any long length of time, during the cold weather, disconnect the batteries and store them in a warm place.

*i. Cold Engine Starting.* Before attempting to start in subzero weather, make certain the consistency of the crankcase oil is such that the engine can be started. Check the controls to make sure they are free and in operating condition. When the engine starts, avoid letting it stall by leaving the choke partly open, but be careful not to flood the carburetor.

*j. Valves.* Be extremely careful in operating all valves as they can be easily damaged in low temperatures.

## **2-19. Operation in Extreme Heat**

When operating in extreme high temperature, efficient cooling and adequate lubrication of the engine and air compressor is vitally important. The cooling system must be checked frequently to make sure the air circulation is not impaired. Give special attention to the engine shrouds and fins for cleanliness. Inspect the carburetor air cleaner frequently. Lubricate more frequently than specified in LO 6-4930-217-12.

## **2-20. Operation in Dusty or Sandy Areas**

Operation of the lubricating and servicing unit in sandy or dusty areas will require more frequent inspections, and lubrication of the unit. Fine sand can penetrate into bushings and bearings. Remove accumulations of sand and dirt at frequent intervals. Inspect the engine and compressor shroud and fins for clogging or impairment of air circulation. Check the fuel system and take all necessary precautions to prevent sand from entering the fuel tank. During shutdown periods, fasten all housing doors securely.

### **2-21. Operation under Rainy or Humid Conditions**

Operation of the lubricating and servicing unit under rainy or humid conditions requires that special attention be given exposed machined parts. A thin coat of oil should be applied to all exposed machined parts to keep them as free of moisture as possible. High moisture content in the air may cause difficulty in the electrical system. The spark plug, magneto and wiring can become unserviceable due to high humidity. Clean and dry affected parts at frequent intervals.

### **2-22. Operation in Salt Water Areas**

In salt water areas, give special attention to general maintenance of the lubricating and servicing units, to prevent corrosion of these

metal parts. Keep a thin coat of oil on all exposed machined parts, and keep as clean and free of moisture as possible. Make sure all unpainted spots are painted or coated with approved preventive compounds. When equipment has been exposed to salt water, steam clean or wash exposed areas with clean, fresh water as soon as possible; dry thoroughly.

### **2-23. Operation in High Altitudes**

The air pressure above sea level decreases as altitude is increased. The result is a decrease in air pressure to the carburetor causing a too rich gasoline air mixture. If this condition interferes with the operation of the unit, adjust the carburetor in accordance with instructions provided in TM 5-2805-203-14.

## **Section V. OPERATION OF MATERIAL USED IN CONJUNCTION WITH THE EQUIPMENT**

### **2-24. Handguns**

*a. General.* A set of handguns, adapters, and couplers (figs. 2-6 and 2-6) are located in the accessory drawers below the hose reels. These handguns are used to dispense small quantities of grease, lubricants other than general purpose grease, and emptying and filling transmissions.

*b. Hand Lever Gun.* The high pressure hand lever gun is used for lubricants required in small quantities, or for dispensing special lubricants. When operating the hand lever gun, best results are obtained by taking full strokes with the lever handle. If a heavy lubricant is used, it may be necessary to prime the lever gun occasionally. Special couplers and adapters provide contact for all types of fittings. To fill the lever gun, proceed as follows

- (1) Unthread head and lever from cylinder.
- (2) Engage follower and push into a full stop.
- (3) Place open end of the cylinder into lubricant approximately 2 inches.
- (4) If barrel is not completely full, pack tight by hand to eliminate air pockets.
- (5) Replace head and lever assembly.

*c. Suction Gun.* Use the suction gun for emptying or filling transmissions, differentials, or any part of a vehicle that requires emptying, other than by drawing through a bottom outlet. Fill the suction gun by inserting the nozzle into the oil or fluid. Pull out the handle as far as it will go. When used for filling purposes, the suction gun is operated by inserting the nozzle into the oil hole. Push the handle forward until a sufficient quantity of oil has been delivered. When used for draining purposes, the suction gun is operated by inserting the nozzle into the drain hole of the housing. Run out the suction gun handle as far as it will go, and a gun full of fluid will be removed. To empty, remove the nozzle from the drain hole and push in the handle as far as it will go.

*d. Pistol Oiler.* Operate the pistol oiler by squeezing the trigger. Use it for applying small quantities of oil to friction points.

### **2-25. Oil Spray Gun, Air Operated**

*a. General.* Use the air operated oil spray gun to obtain oil spray at high pressures. The gun consists of an oil spray container and a head with an air valve. Separate controls and adjust both the input quantity of air and the quantity of air ejected. An adjustable

nozzle permits either a steady stream, or spray type oil ejection.

*b. Operation.* Fill the container with the desired grade of oil. Screw the container into the head. Attach the air line coupler of the spray gun to the air line coupler (43, fig. 2-3) of the hose on the lubricating unit. Turn the adjustable nozzle to the closed position. Press the air valve button and open the nozzle until desired amount of oil ejection is obtained.

## 2-26. Pneumatic Gun

The pneumatic gun may be attached to the air line coupler (43, fig. 2-3 ) of the air hose on the lubricating unit to permit cleaning with air pressure.

## 2-27. Accessory Equipment

*a. Air Chuck and Gauge.* An air chuck and gage with quick-operating air line coupling nipple, used for inflating tires, is located in the upper drawer assembly.

*b. Hacksaw Frame and Blade.* The hacksaw frame and blade, for use in cutting hose, when replacing reusable hose and fittings, are located in the upper accessory drawer.

*c. Padlock.* Two padlocks with two keys per lock, are used for locking the toolbox and both repair drawers.

*d. Air Line Coupling Socket and Nipple.* Two air line coupling sockets and nipples, to replace socket or nipple when necessary, are located in the accessory drawer.

*e. High Pressure Hose End Fittings.* Two hose and coupling fittings for high pressure lubricant hoses, are located in the lower accessory drawer.

*f. Air Hose End Fittings.* Two each male and female reusable hose end fittings of ¼ inch inside diameter air hoses, are located in the lower drawer.

*g. Hose Adapter Coupling.* Two hose adapter couplings to join high pressure lubricate hoses, are located in the lower drawer.

*h. Giant Buttonhead Hode Assembly (flexible extension adapter).* Two giant buttonhead whip-end hoses each, with a 500 psi pressure relief valve, and equipped with, giant buttonhead fittings, are part of the accessory equip-

ment on the lubricating unit and are stored in the lower drawer.

*i. Buttonhead Fittings.* Six each buttonhead fittings, to be used as replacement parts, are located in the lower drawer.

*j. Extension Hydraulic Pressure Relief Adapter.* One extension hydraulic pressure relief adapter with 500 psi pressure relief valve, is furnished on the lubricating unit. The adapter is to be used for greasing seal-type lubrication points, to prevent rupturing seals when using power lubricating equipment, A sliding sleeve locks firmly on the coupler of the hydraulic adapter.

*k. Straight Hydraulic Fittings.* Six each straight hydraulic fittings to replace defective fittings of varying sizes, are located in the lower drawer.

*l. Forty-five Degree Hydraulic Lubrication Fittings.* Six each 45° hydraulic fittings to replace defective fittings if necessary, are located in the lower drawer.

*m. Easy-Out Tool.* Two easy-out tools are used for removing grease fittings. They are located in the lower drawer.

*n. Pneumatic Gun.* The pneumatic gun is used to control a stream of compressed air. The air is used for drying parts, or for blowing dirt and debris from cylinder heads or other components.

*o. Straight and Z-Swivels.* A straight and Z-swivel is used for connecting the control valves to the supply hoses; thus permitting the valve to swivel for easy access to hard-to-reach fittings. The swivels are located in the lower drawer.

*p. Portable Lubricator.*

(1) *Description.* The portable lubricator (2, fig. 2-3) is a self-contained unit and can be strapped to the operator's back. An air power piston forces grease to a booster valve, where pressure is built up by squeezing the valve handle.

(2) *Operation.*

(a) With the lubricator (fig. 2-7) empty of grease, remove the valve cap from the valve stem (11) located on the bottom of the tank. Charge the tank to 40 psi.

(b) Remove pin (7) and insert hose assembly (5) into connector as far as it will go. Replace pin (7) to its full length and check to be sure hose assembly (5) fits tight in connector.

(c) Fill the lubricator with grease until the indicator valve (4) indicates when the lubricator is full. Do not overfill.

(d) Insert other end of hose (5) into the body of the booster valve and screw the swivel fitting assembly (12) hand tight.

(e) Open the air relief valve on the booster valve until grease flows in a steady stream. Close the relief valve. The unit is now ready for use.

Note. The portable lubricator need not be refilled with air each time grease is completely expelled. The air charge will last about a year.

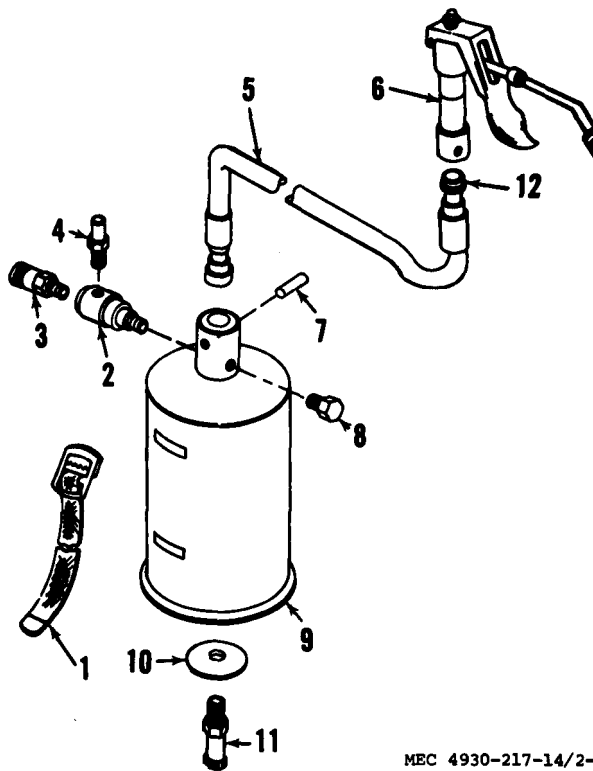

MEC 4930-217-14/2-

- |             |                  |
|-------------|------------------|
| 1 Strap     | 7 Pin            |
| 2 Adapter   | 8 Valve          |
| 3 Fitting   | 9 Container assy |
| 4 Valve     | 10 Plate         |
| 5 Hose assy | 11 Valve stem    |
| 6 Gun assy  | 12 Fitting assy  |

Figure 2-7. Portable lubricator.

## 2-28. Fire Extinguisher

a. *Description.* The portable carbon dioxide type fire extinguisher is suitable for electrical and flammable liquid fires.

b. *Operation.* Remove fire extinguisher from its location; break the seal, operate the control valve, and direct the stream at the base of the flame.

c. *Maintenance.* For maintenance of the fire extinguisher, refer to TM 5-687.

## 2-29. Heat Diverter Controls

a. *Exhaust Heat Diverter.* The two exhaust heat diverter levers (22, fig. 2-3) ducts gas either to a heat reservoir beneath the lubricant container or directly to atmosphere.

b. *Operation in Cold Weather.*

(1) In cold weather operation, duct exhaust gas to the heat reservoir.

(2) Start the engine (para 2-11) and close all doors on the lubricating unit.

(3) Allow the engine to run for about ten minutes with the air tank drain valve (44, fig. 2-3) open.

(4) Close the air tank drain valve (44, fig. 2-3); wait until the compressor unloads before using the lubricating pump.

## 2-30. Alcohol Dispenser

a. *General.* Use the alcohol dispenser (6, fig. 2-3) when temperature is below 32°F. The dispenser is used to inject alcohol into the air line leading to the pump to prevent condensate freezeup. The alcohol dispenser is equipped with an eight-ounce capacity metal bowl and a needle valve, which controls the flow of alcohol.

b. *Operation (fig. 2-8).*

(1) Shut down the unit (para 2-12).

(2) Remove plug handle anti fill with alcohol. Reinstall handle.

(3) Start engine (para 2-11).

(4) During operation, inspect sight gage frequently and refill when necessary.

(5) Open needle valve approximately ¼ turn.

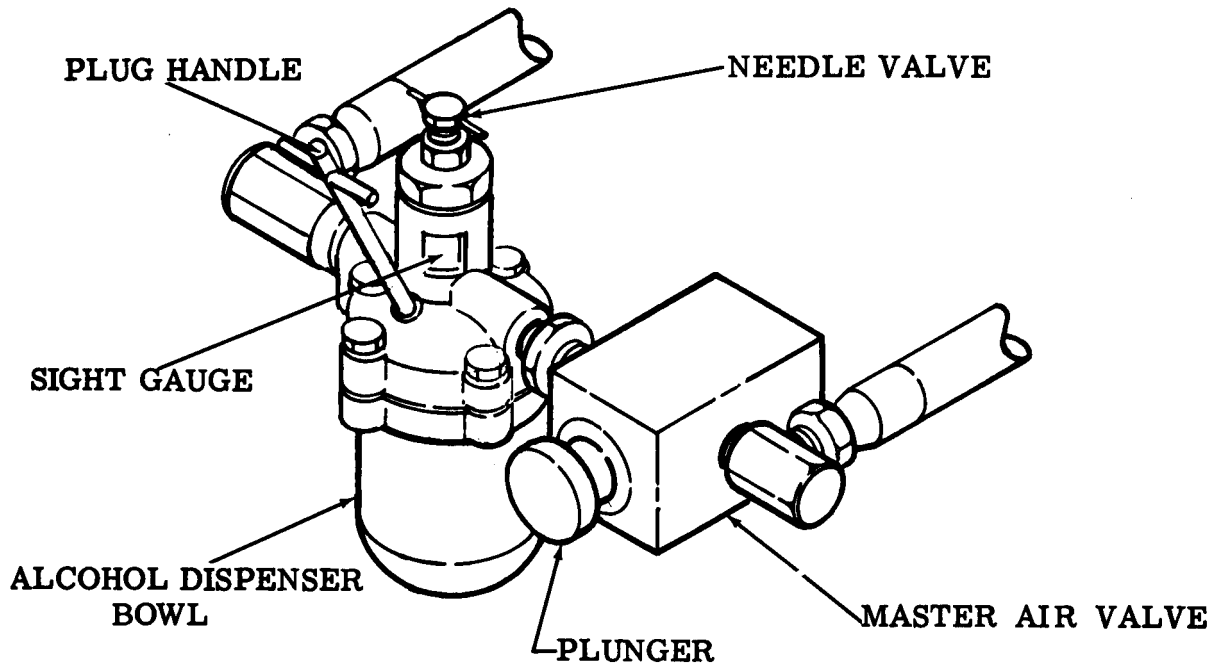

**NOTE: PULL OUT PLUNGER TO RELEASE AIR TO THE LUBE PUMPS AND PUSH THE PLUNGER TO STOP THE AIR.**

MEC 4930-217-14/2-8

*Figure 2-8. Alcohol dispenser assembly and master air valve.*

CHAPTER 3  
OPERATOR AND ORGANIZATIONAL MAINTENANCE  
INSTRUCTIONS

---

**Section I. SPECIAL TOOLS AND EQUIPMENT**

**3-1. Special Tools and Equipment**

No special tools or equipment are required by the operator or organizational maintenance personnel for the lubricating and servicing unit.

**3-2. Basic Issue Tools and Equipment**

Tools and equipment issued with or authorized for the lubricating and servicing unit are listed in appendix B of this manual.

**Section II. LUBRICATION**

**3-3. General Lubrication Information**

*a.* This section contains a reproduction of the lubrication chart and lubrication instructions which are supplemental to, and not specifically covered in LO 6-4980-217-12.

*b.* The lubrication chart for the lubricating and servicing unit is shown in LO 6-4930-217-12.

**3-4. Detailed Lubrication Information**

*a. Care of Lubricants.* When lubricating the unit, apply the various lubricants carefully. Keep the lubricant containers clean and free from foreign matter. Cover all containers tight

after use so that the contents will remain usable.

*b. Points of Lubrication.* Lubrication points are readily located by reference to LO 5-4930-217-12.

*c. Cleaning.* Use an approved cleaning solvent to clean all fittings and surrounding surfaces before lubricating. Dry parts thoroughly after cleaning.

*d. Operation Immediately After Lubrication.* Start and run the equipment for about five minutes after lubrication. Check carefully for any sign of oil leaks or faulty grease fittings. Should such signs appear, correct or report to proper authority prior to operating equipment.

*Figure 3-1. Not used.*

**Section III. PREVENTIVE MAINTENANCE SERVICES**

**3-5. General**

To insure that the lubricating and servicing unit is ready for operation at all times, it must be inspected systematically so that defects may be discovered and corrected before they result in serious damage or failure. The necessary preventive maintenance services to be performed are listed and described in paragraphs 3-6 and 3-7. The item numbers in-

dicating the sequence of minimum inspection requirements. Defects discovered during operation of the unit shall be noted for future correction, to be made as soon as operation has ceased. Stop operation immediately if a deficiency is noted during operation which would damage the equipment if operation were continued. All deficiencies and shortcomings will be recorded together with the corrective

## PREVENTIVE MAINTENANCE SERVICES DAILY

TM5-4930-217-14

ELLIOTT MACHINE WORKS MODEL ENG-3

LUBRICATING AND SERVICING UNIT

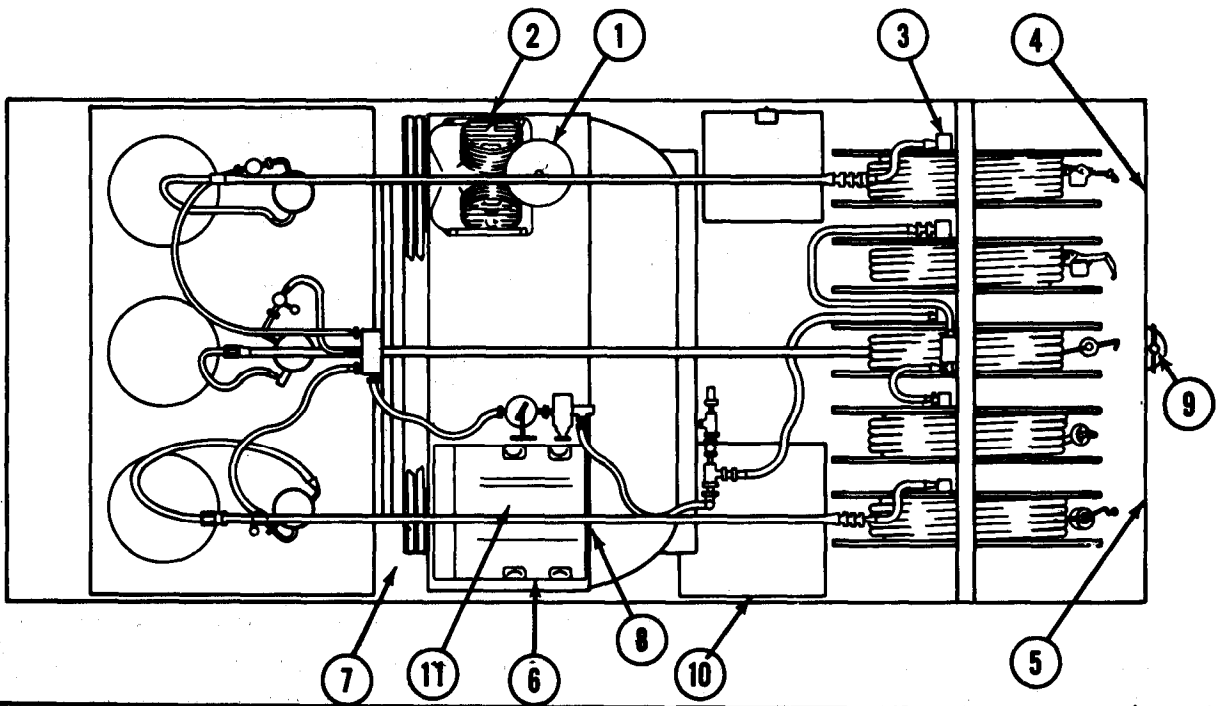

ITEM	LUBRICATE IN ACCORDANCE WITH CURRENT LUBRICATION CHART	PAR REF
1	<b>COMPRESSOR AIR CLEANER.</b> Inspect for secure mounting and loose connections. Inspect for cleanliness.	
2	<b>COMPRESSOR.</b> Inspect compressor head and cooling fins for any accumulation of dirt or rust.	
3	<b>LEAKS.</b> Check for lubrication leaks and air leaks. Check swivel joints at hose reel inlets.	
4	<b>TOOLS AND EQUIPMENT.</b> See that all tools and equipment assigned to the unit are in serviceable condition, clean and properly stowed.	
5	<b>BATTERIES.</b> Check condition of batteries. Maintain proper electrolyte level. Make sure all cables are tight.	
6	<b>ENGINE.</b> Inspect cylinder head and cooling fins for any accumulation of dirt or rust.	
7	<b>INSTRUMENTS.</b> Check all gauges for broken glass and secure mounting.	
8	<b>FUEL FILTER.</b> Inspect the filter sediment bowl for any accumulation of water. Clean bowl and screen if dirt or water are present.	
9	<b>DRAINCOCK.</b> Open the draincock for a short time to release moisture in the air receiver.	
10	<b>FUEL TANK.</b> Check fuel tank, fuel lines, and connections for leaks.	
11	<b>ENGINE AIR CLEANER.</b> Inspect for secure mounting and loose connections. Check the condition of, and level of, oil in the bowl.	

MEC 4930-217-14/3-2 ①

*Figure 3-2①. Daily preventive maintenance services.*

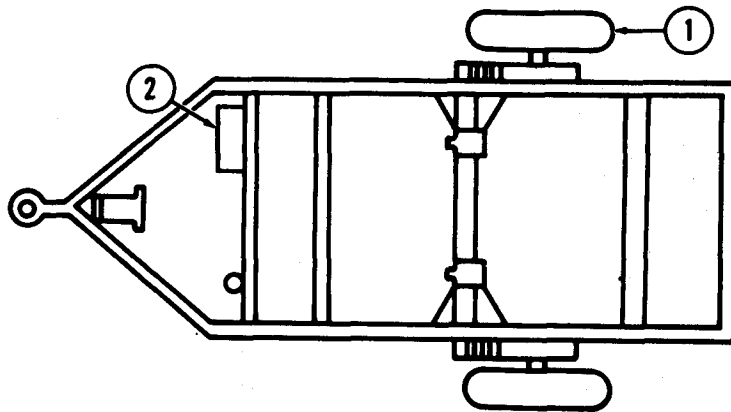

ITEM	LUBRICATE IN ACCORDANCE WITH CURRENT LUBRICATION CHART	PAR REF
1	TIRES. Perform visual check for proper inflation.	
2	AIR BRAKE RESERVOIR. Drain moisture from tank.	

MEC 4930-217-14/3-2 ②

Figure 3-2 ② -Continued.



## PREVENTIVE MAINTENANCE SERVICES QUARTERLY

TM5-4930-217-14

ELLIOTT MACHINE WORKS MODEL ENG-3 LUBRICATING AND SERVICING UNIT

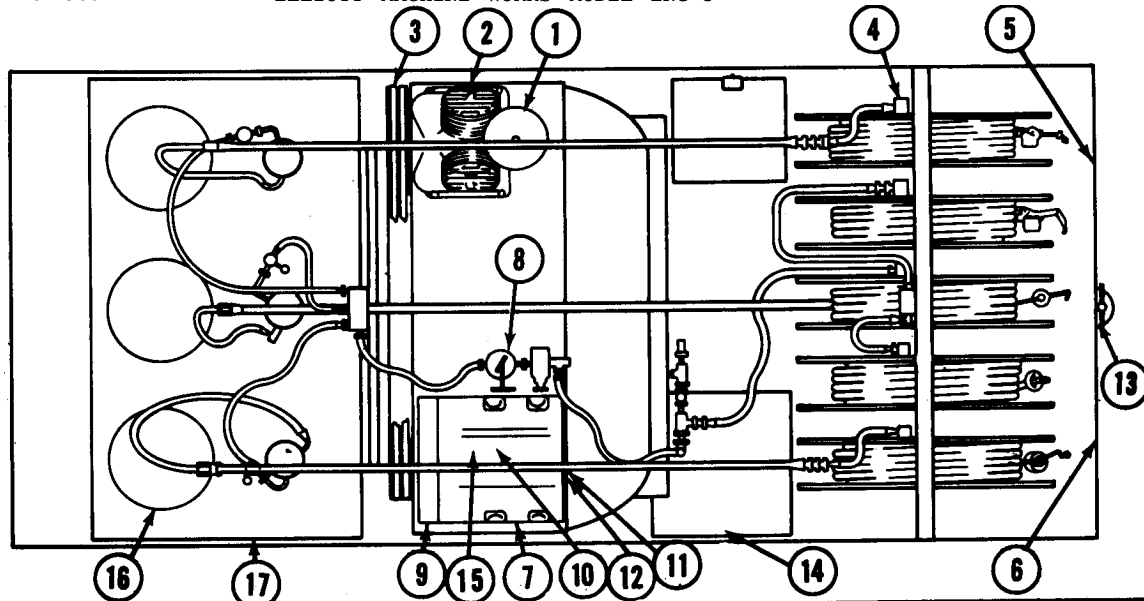

ITEM	LUBRICATE IN ACCORDANCE WITH CURRENT LUBRICATION CHART	PAR REF
1	COMPRESSOR AIR CLEANER. Inspect for secure mounting and loose connections. Inspect for cleanliness.	
2	COMPRESSOR. Inspect compressor head and cooling fins for any accumulation of dirt or rust.	
3	BELTS AND PULLEYS. Inspect condition and tension of drive belts and pulleys. Belts should readjusted only tight enough to prevent slippage.	
4	LEAKS. Check for lubrication leaks and air leaks. Check swivel joints at hose reel inlets.	
5	TOOLS AND EQUIPMENT. See that all tools and equipment assigned to the unit are in serviceable condition. Clean and properly stow.	
6	BATTERIES. Check condition of batteries. Maintain proper electrolyte level. Make sure all cables are tight.	
7	ENGINE. Inspect cylinder head and cooling fins for any accumulation of dirt or rust.	
8	ALCOHOL INJECTOR. Inspect injector for proper operation, leakage and secureness of attachment.	
9	INSTRUMENTS. Check all gauges for broken glass and secure mounting.	
10	CARBURETOR AND LINKAGE. Check the carburetor and linkage to see that they are in good condition, correctly installed and assembled. See that carburetor does not leak, that linkage is not work or binding. See that choke valve opens fully when control is in released position.	
11	FUEL PUMP AND HOUSING. Inspect the fuel pump and fuel lines for gasoline leaks. Check for oil leaks where the pump is fastened to the engine block and check for loose mounting and screws. Diluted oil indicates a faulty fuel pump.	
12	FUEL FILTER. Inspect the filter sediment bowl for any accumulation of water. Clean bowl and screen if dirt or water are present.	
13	DRAINCOCK. Open the draincock for a short time to release moisture.	
14	FUEL TANK. Check fuel tank, fuel lines, and connections for leaks.	
15	ENGINE AIR CLEANER. Inspect for secure mounting and loose connections. Check the condition and level of oil in bowl.	
16	LUBRICATION PUMPS. Inspect, pumps for leakage and secureness of attachment. Inspect pump hoses.	
17	LUBRICANT HOPPERS. Inspect hoppers for cleanliness and leakage.	

MEC 4930-217-14/3-3 ①

Figure 3-3 ①. Quarterly preventive maintenance services..

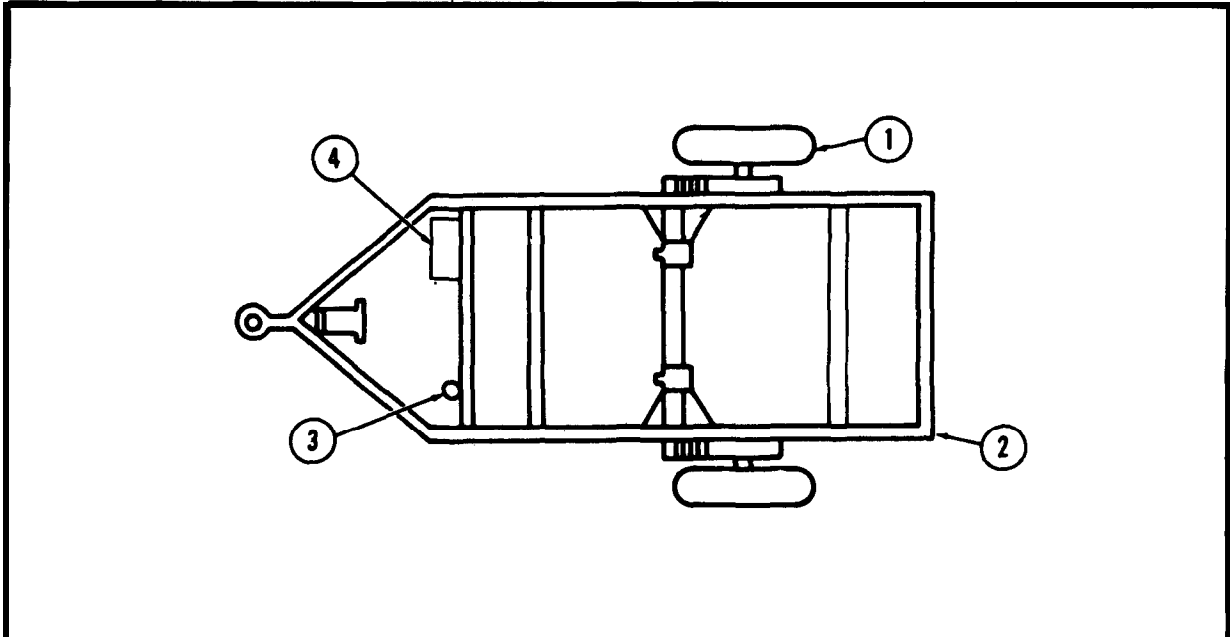

ITEM	LUBRICATE IN ACCORDANCE WITH CURRENT LUBRICATION CHART	PAR REF
1	TIRES. Check for proper inflation Inflate to 50 psi.	
2	LIGHTS. Check for proper operation and defective wiring.	
3	MASTER CYLINDER AND BRAKE AIR CHAMBER. Check for leaks, loose fittings, and secure mountings.	
4	AIR BRAKE RESERVOIR Inspect for leaks and loose mounting.	
<p style="text-align: center;">NOTE: Operational Test. During operation, check for unusual noise or vibration and proper operation.</p>		

MEC 4930-217-14/ 3-3 ②

Figure 3-3 ② -Continued.

action taken on DA Form 2404 (Equipment Inspection and Maintenance Worksheet) at the earliest possible opportunity.

### 3-6. Daily Preventive Maintenance Service

This paragraph contains an illustrated tabulated listing of preventive maintenance services which must be performed by the operator. The item numbers are listed consecutively and indicate the sequence of minimum requirements. Refer to figure 3-2 for the daily preventive maintenance services.

### 3-7. Quarterly Preventive Maintenance Service

*a.* This paragraph contains an illustrated tabulated listing of preventive maintenance services which must be performed by organizational maintenance personnel at quarterly intervals. A quarterly interval is equal to three calendar months or 250 hours of operation, whichever comes first.

*b.* The item numbers are listed consecutively and indicate the sequence of minimum requirements. Refer to figure 3-3 for the quarterly preventive maintenance services.

## Section IV. OPERATOR'S MAINTENANCE

### 3-8. General

Instructions in this section are published for the information and guidance of the operator to maintain the lubricating and servicing unit.

### 3-9. Alcohol Dispenser

*a. General.* Use the alcohol dispenser (6, fig. 2-3) during cold weather operation. The dispenser is used to inject alcohol into the air

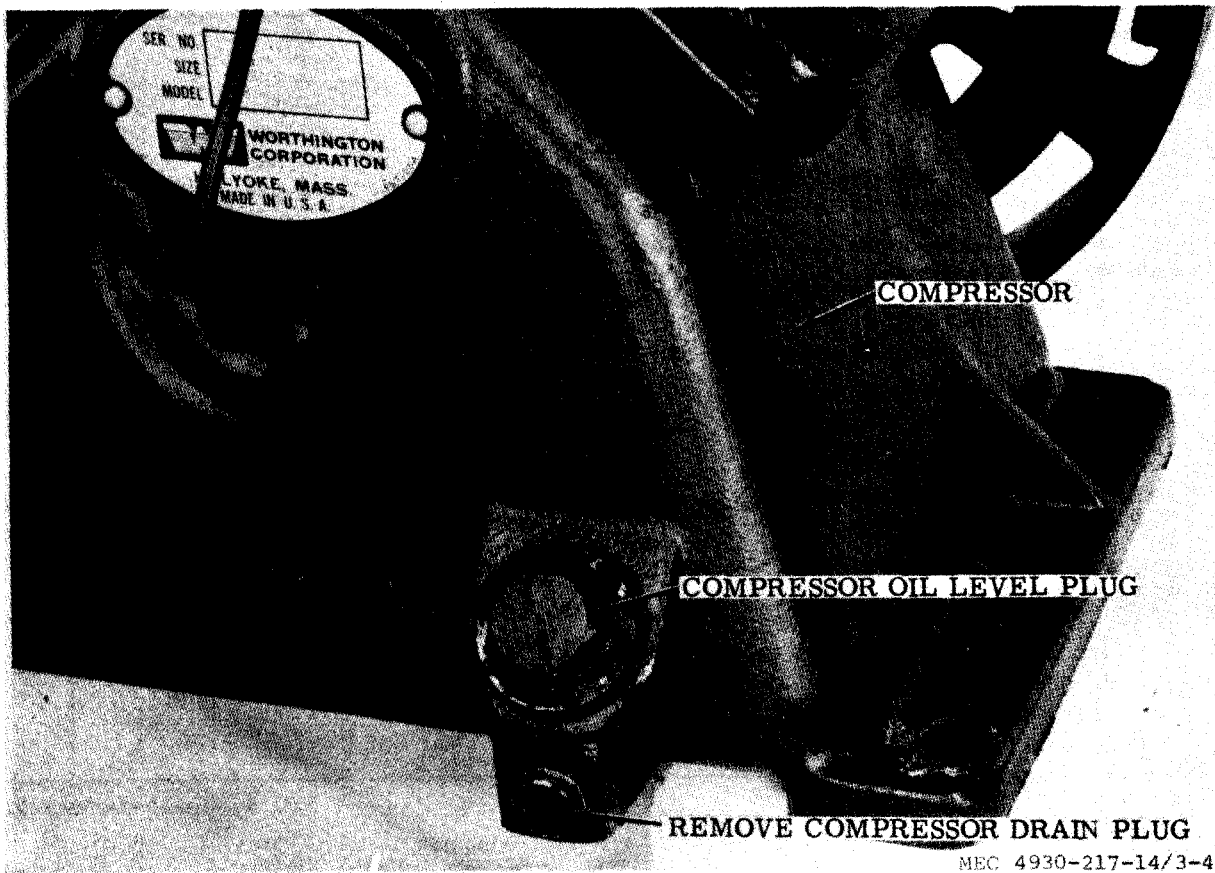

Figure 3-4 Compressor oil level plug and drain plug—removal and installation.

line leading to the pump to prevent condensate freezeup. The alcohol dispenser is equipped with an eight-ounce capacity metal bowl and a needle valve which controls the flow of alcohol.

*b. Service (fig. 2-8).*

- (1) Shut down the unit (para 2-12).
- (2) Remove plug handle and fill with alcohol. Reinstall handle.
- (3) Start engine (para 2-11).
- (4) During operation, inspect sight gauge frequently and refill when necessary.
- (5) Open needle valve to increase and close to decrease flow of alcohol.

### 3-10. Air Compressor

*a. Oil Level.* To check the oil level in the compressor, remove oil filler plug (fig. 3-4). Oil level should be even with the bottom threads of the filler plughole.

*b. Air Cleaner.* The air cleaner (fig. 3-5) is equipped with a filter element (4) to filter out all dirt. The element must be cleaned or replaced to insure clean air and to prevent wear due to dirt. Remove wing nut (1) and cover (2) to gain access to the filter element. Replacement of the element is preferred.

*c. Air Receiver.* Clean the air receiver with an approved solvent. Clean the tank with a wire brush. Inspect all parts for dents, bends, and other damage. Report all damage. Drain the air receiver of moisture by opening the air tank drain valve (44, fig. 2-3).

*d. Compressor Drive Belt Adjustment.* Adjust as follows:

- (1) Loosen the engine attaching hardware.
- (2) Move the engine toward or away from the compressor and check for proper belt tension at the midway point between the pulleys. When belt can be depressed  $\frac{1}{2}$  to  $\frac{3}{4}$  inch, tension is proper.
- (3) Tighten the engine attaching hardware and replace the belt guard.

### 3-11. Engine

Refer to TM 5-2805-203-14 for servicing the engine.

### 3-12. Drive Sheave

Keep the drive sheave (4, fig. 3-7) free from dirt, grease and foreign matter at all times to prevent belt slippage and damage to belts or drive sheave.

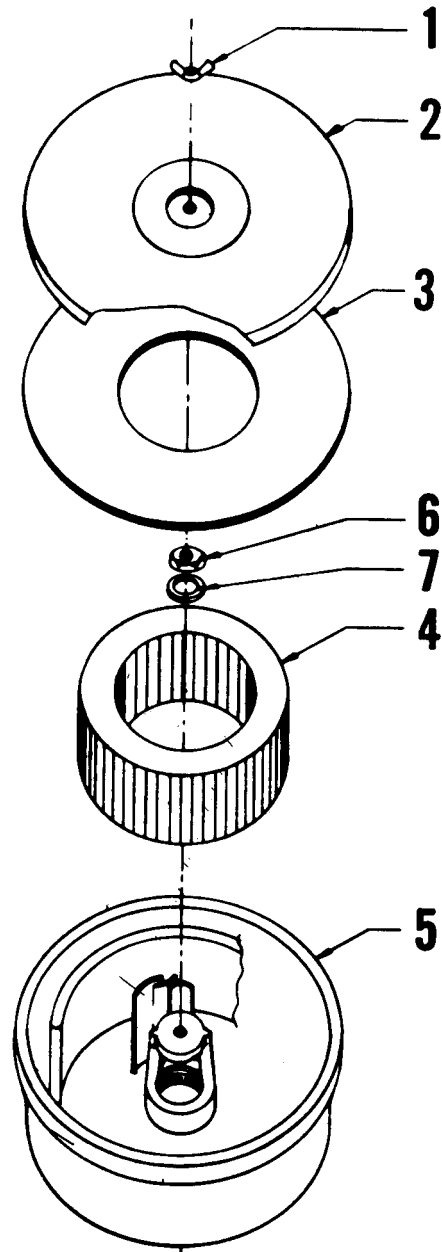

MEC 4930-217-14/3-5

- |            |          |          |
|------------|----------|----------|
| 1 Wing nut | 4 Filter | 6 Nut    |
| 2 Cover    | 5 Body   | 7 Washer |
| 3 Gasket   |          |          |

Figure 3-5. Compressor air cleaner-exploded view.

### 3-13. Fuel Tank

Fill fuel tank prior to operating the unit. Use gasoline, automotive combat type I or II.

*Note.* Do not fill fuel tank during operation of lubrication unit.

### 3-14. Generator Drive Belt Adjustment

Belts should only be adjusted tight enough to prevent slippage. Loosen the generator adjusting link (37, fig. 3-7) and pull the generator in a direction which tightens the drive belt, hold the generator in place and tighten bolt (40A).

### 3-15. Batteries

Perform the following in testing and servicing the batteries.

*a.* Check the battery for proper electrolyte level ( $\frac{1}{4}$  in. below the filler holes), Fill as required.

**Warning: Clean up any spilled electrolyte with water. Keep electrolyte off the skin to prevent personal injury.**

*b.* Maintain clean batteries and cable connections to prevent corrosion.

*c.* Make sure all cables are properly installed and are tight.

### 3-16. Trailer Brakes

*a. Master Cylinder Assembly.* Refer to LO 5-4930-217-12 and service as required.

#### *b. Air Fitter.*

##### *(1) Draining Air filter.*

*(a)* Remove the end plug (7, fig. 3-19) from the housing nut (6).

*(b)* Allow all condensation to drain from the filter (2). Wipe housing nut clean.

*(c)* Install the end plug in the housing nut.

##### *(2) Removal and installation of air filter element.*

*(a)* Remove the housing nut (6, fig. 3-19).

*(b)* With the housing nut removed, the fiber washer (5), spring (4), air filter washer (3) and filter (2) will slide from the housing (1).

*(c)* Clean all parts, including the housing, with cleaning solvent.

*(d)* If the filter is damaged or soaked with oil or gummy deposits, replace it with a new one.

*(e)* Install the air filter in reverse order of disassembly.

*c. Air Reservoir.* Open the drain cock on the bottom of the air reservoir to drain moisture. Refer to figure 1-2 for location of air reservoir.

*d. Wheel Bearings.* Lubricate the wheel bearings in accordance with LO 6-4930-217-12.

### 3-17. Tires

Maintain proper tire pressure which is 5 pounds normal and 40 pounds on sandy or rough terrain.

### 3-18. Landing Gear leveling Jacks

Lubricate fitting (8, fig. 3-20). Tighten all nuts, bolts and support parts to insure a secure prop for the trailer.

### 3-19. Pumps

*a.* Clean exterior of pumps with approved cleaning solvent.

*b.* Check all fittings and lines for loose connections.

*c.* Tighten all loose connections.

### 3-20. Lamps, Incandescent

*a. Lamp Incandescent, Trouble Light.* Remove the lamp (11A, fig. 3-6) by pushing in and turning counterclockwise until the lamp releases from its socket (approximately  $\frac{1}{2}$  turn). Replace the lamp in reverse of removal.

#### *b. Lamps Incandescent Control Panel.*

*(1) Removal.* Pull off the two lamp covers and remove the two lamps (101A, fig. 3-8) by pushing in on the lamp and turning it counterclockwise approximately  $\frac{1}{2}$  turn or until the lamp releases from its socket.

*(2) Installation.* Replace the lamps in reverse of removal.

### 3-21. Trailer Lamps

Remove and install the trailer lamps as shown in figure 3-9.

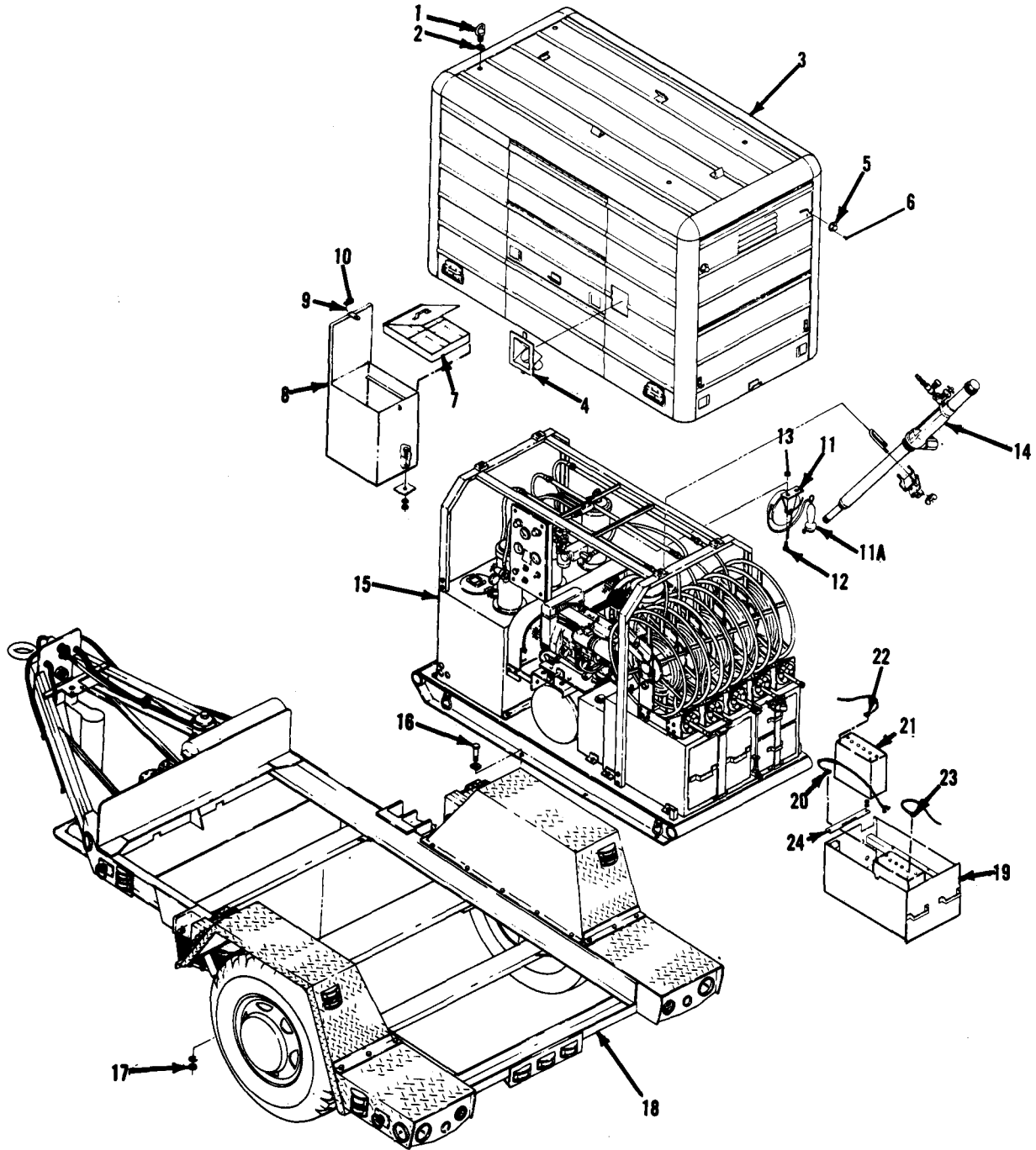

MEC 4930-217-14/3-6

- |                       |                        |                  |
|-----------------------|------------------------|------------------|
| 1 Lifting ring (4)    | 10 Toolbox             | 17 Lock nut      |
| 2 Gasket (4)          | 11 Trouble light reel  | 18 Trailer assy  |
| 3 Enclosure Assembly  | 11A Lamp, incandescent | 19 Battery box   |
| 4 Fuel filler housing | 12 Capscrew (2)        | 20 Battery cable |
| 5 Polar latch (4)     | 13 Nut (2)             | 21 Battery (2)   |
| 6 Capscrew (16)       | 14 Transfer pump       | 22 Battery cable |
| 7 Toolbox tray        | 15 Lubrication unit    | 23 Battery cable |
| 8 Toolbox             | 16 Capscrew            | 24 Link          |
| 9 Chain               |                        |                  |

Figure 3-6. Lubrication unit-major components, exploded view.

### 3-22. Fire Extinguisher (Carbon Dioxide Type)

*a. Description.* The portable carbon dioxide type fire extinguisher is suitable for electrical and flammable liquid fires.

*b. Operation.* Remove fire extinguisher from its location; break the seal, operate the control valve, and direct the stream at the base of the flame.

*c. Maintenance.* For maintenance of the fire extinguisher, refer to TM 5-687.

## SECTION V. TROUBLESHOOTING

### 3-23. General

This section provides information useful in diagnosing and correcting unsatisfactory operation or failure of the lubricating and servicing unit and its components. Each trouble symptom stated is followed by a list of probable causes of trouble. The possible remedy recommended is described opposite the probable cause. Any trouble beyond the scope of organizational maintenance shall be reported to direct support.

### 3-24. Compressor Overheats

<i>Probable Cause</i>	<i>Possible Remedy</i>
Ventilation inadequate ..	Provide adequate ventilation around unit.
Cooling fins dirty -----	Clean compressor thoroughly (part 7-2c).
Low oil level ____	Add necessary oil to proper level LO 6-4930-217-12.
V-belts slipping _____	Adjust V-belts correctly (para 3-10d).
Dirty air cleaner _____	Service air cleaner (para 3-10b) .
Faulty valves _____	Replace faulty valves (direct support) (para 7-4).

### 3-25. Compressor Noisy

<i>Probable Cause</i>	<i>Possible Remedy</i>
Low oil level ___ -_-_-	Add correct oil to high level (LO 5-4930-217-12).
Loose fly wheel or engine pulley.	Tighten pulleys securely.
Worn V-belts _____	Replace worn V-belts (para 3-41).

### 326. Compressor Pumps too Slowly or Fails to Buildup Pressure

<i>Probable Cause</i>	<i>Possible Remedy</i>
Air cleaner dirty and clogged.	Service air cleaner. Clean thoroughly or replace (para 3-10).
V-belts improperly adjusted.	Adjust V-belts to proper tension (para 3-10d).
Low oil level -----	Check oil level in crankcase and fill to high level mark

#### *Probable Cause*

#### *Possible Remedy*

	with correct oil LO 6-4930-217-12.
Excessive dirt around cooling fins.	Clean compressor thoroughly.
Faulty valves _____	Replace valves (direct support) .

### 3-27. Compressor V-Belts Worn Excessively

<i>Probable Cause</i>	<i>Possible Remedy</i>
Pulleys out of alinement_	Aline pulleys (para 3-53).
V-belts too loose or too tight.	Adjust V-belts (para 3-10d).
Oil or grease in V-belts--	Replace V-belts (para 3-41).

### 3-28. Lubricant Delivery Faulty

<i>Probable Cause</i>	<i>Possible Remedy</i>
Dirty or sticking con-	Clean thoroughly with approved solvent.
Leak in lines -----	Tighten connections with couplings. Replace defective hoses.

### 3-29. Lubricant Pump Fails to Operate Properly

<i>Probable Cause</i>	<i>Possible Remedy</i>
Faulty connections in grease line.	Inspect line for leaks in hose, swivels, connectors, control handle and pipe line.
Inadequate supply of air-	Inspect air connections to pump.

### 3-30. Insufficient Pressure or Volume with Pump Going

<i>Probable Cause</i>	<i>Possible Remedy</i>
Exhausted lubricant supply.	Refill lubricant containers.
Circulation of grease slow.	Push grease down around pump intake priming tuba and use exhaust to warm grease.
Insufficient air pressure supplied to pump.	If necessary, set air regulator to higher pressure. Check for closed or inoperative valves or obstruc-

### 3-31. Hose Reels do not Turn Properly

<i>Probable Cause</i>	<i>Possible Remedy</i>
Loose mounting . -----	Tighten hose reels at reel hub.
Defective reel brake ----	Replace the reel brake.

### 3-32. Oil Consumption Excessive

<i>Probable Cause</i>	<i>Possible Remedy</i>
Low oil supply _____	Drain, fill with correct oil.
Leak at air filter cap ___	Replace oil filter cap.

## Section VI. RADIO INTERFERENCE SUPPRESSION

### 3-33. Definitions

*a. Interference.* The term "interference" as used herein applies to electrical disturbances in the radio frequency range which are generated by the lubricating and servicing unit and which may interfere with the proper operation of radio receivers or other electronic equipment, or enable the enemy to locate the equipment.

*b. Interference Suppression.* The term "interference suppression" as used herein applies to the methods used to eliminate or effectively reduce radio interference generated by the lubricating and servicing unit.

### 3-34. General Methods Used to Attain Proper Suppression

*a.* Essentially, suppression is attained by providing a low resistance path to ground stray currents. Methods used include shielding the ignition and high frequency wires, grounding the frame with bonding straps, and using capacitors and resistors.

*b.* Refer to TM 5-2805-203-14 for interference suppression of the engine.

### 3-35. Interference Suppression Components

*a. Generator Capacitor.* Test capacitor for leaks and shorts on a capacitor tester; replace defective capacitor.

*b. Engine.* Refer to TM 5-2805-203-14 for engine suppression components.

## Section VII. ENCLOSURE ASSEMBLY, BATTERY DRAWER, TOOLBOX AND TROUBLE LIGHT

### 3-36. General

The enclosure assembly (3, fig. 3-6) consists of the front and rear door assemblies and two identical side door assemblies. Each door assembly consists of two panels with latches (5) for securing panel and two slide locking devices. The enclosure itself is provided with four hand lifting devices, one at each side corner.

### 3-37. Enclosure Assembly

#### *a. Removal.*

(1) Unscrew and remove the four lifting rings (1, fig. 3-6) on top of the enclosure assembly.

(2) Disconnect fuel filler hose (80, fig. 3-8).

(3) Using the four hand lifting devices, (two riveted on each side of enclosure) carefully lift the enclosure assembly up and over the lubricator internal equipment and off of the frame.

#### *b. Installation.*

(1) Carefully lift the enclosure assembly up and over the lubrication unit (15, fig. 3-6) being certain to align the enclosure assembly with the frame.

(2) Lower the enclosure in position aligning holes provided for lifting rings.

(3) Install the lifting rings (1) in position and tighten.

(4) Install fuel filler hose (80, fig. 3-8).

*Note.* Make sure that doors are secure before lifting enclosure.

### 3-38. Battery Drawer

*a. Removal.* The battery drawer can be disassembled into its components parts by referring to figure 3-6, index numbers 19 through 24.

*b. Cleaning and Inspection.* Refer to paragraphs 2-3 and 2-4.



*c. Installation.* Installation is the reverse of removal. Refer to figure 3-6.

### 3-39. Toolbox, Trouble light Reel and Filler Housing

*a. Removal.* The toolbox (8) can be removed as shown in figure 3-6. Tag and disconnect electrical leads and remove the trouble light reel (11) by removing the attaching hardware (12 and 13). Remove the fuel filler housing (4) by turning latch (located behind the housing inside the enclosure 90° in any direction.

*b. Cleaning and Inspection.*

(1) Remove any dents in the toolbox and filler housing. Check that the toolbox door closes easily and that the filler housing fits within the enclosure snugly.

(2) Check the bulb in the trouble light and replace if defective (para 3-20). Pull out the reel and then let it rewind. If the reel does not operate, replace it.

*c. Installation.* Installation is the reverse of removal. Refer to figure 3-6 as an aid to installation.

## Section VIII. ENGINE ASSEMBLY

### 3-40. General

The engine assembly is a 4-cylinder, air cooled overhead valve, gasoline operated device. It is capable of satisfactory operation in temperate, desert, arctic, and tropical environment when serviced regularly.

### 3-41. Engine Assembly

*a. Removal.*

(1) Remove enclosure as described in paragraph 3-37.

(2) Disconnect the fuel line, choke control cable and the throttle control cable before removing engine.

(3) Loosen the four bolts, nuts, and washers attaching the engine (7, fig. 3-7) to the mounting base (8) on the tank (41).

(4) Tag and disconnect electrical leads to the starter assembly and oil pressure gage on

control panel from oil pressure transmitter (44).

(5) Remove the two compressor drive belts (39).

(6) Remove engine attaching hardware and remove the engine.

*b. Installation.*

(1) Lower engine assembly (7, fig. 3-6) over mounting plate holes being certain to align holes in engine bracket mounting base (8).

(2) Install attaching hardware and finger tighten. Final tightening is accomplished after installation and adjustment of drive belts (39 and 40). Refer to paragraph 3-10 for adjustment of drive belts.

(3) Install components to the engine assembly in the reverse order of removal.

### 3-42. Engine Lubrication System

Refer to TM-2805-203-14 for further information on the engine.

---

1 Belt guard	17 Elbow	33C Nut (2)
1A Cap screw (4)	18 Coupling	34 Bracket
2 Flat washer (4)	19 Tee	35 Generator
3 Nut (4)	20 Nipple	36 Support
5 Set screw	21 Bushing	36A Bolt
6 Exhaust diverter	22 Nipple	36B Washer
6A Cap screw (2)	23 Valve	37 Adjusting link
6B Lock washer (2)	24 Nipple	38 Belt guard
6C Nut (2)	25 Tee	38A Bolt
7 Engine	26 Safety valve	39 Compressor belt (2)
8 Mounting base	27 Starter	40 Generator belt
9 Compressor	28 Extension	40A Bolt
10 Mounting	29 Nipple	40B Washer
11 Trough	30 Elbow	40C Nut
12 Lever	31 Nipple	41 Air receiver tank
13 Throttling device	32 Adapter	42 Bracket
14 Elbow	33 Exhaust diverter	43 Low oil pressure switch
15 Tube assembly	33A Cap screw (2)	44 Oil pressure transmitter
16 Nipple	33B Lock washer (2)	45 Tee

*Figure 3-7. Engine, compressor and air tank receiver assembly.*

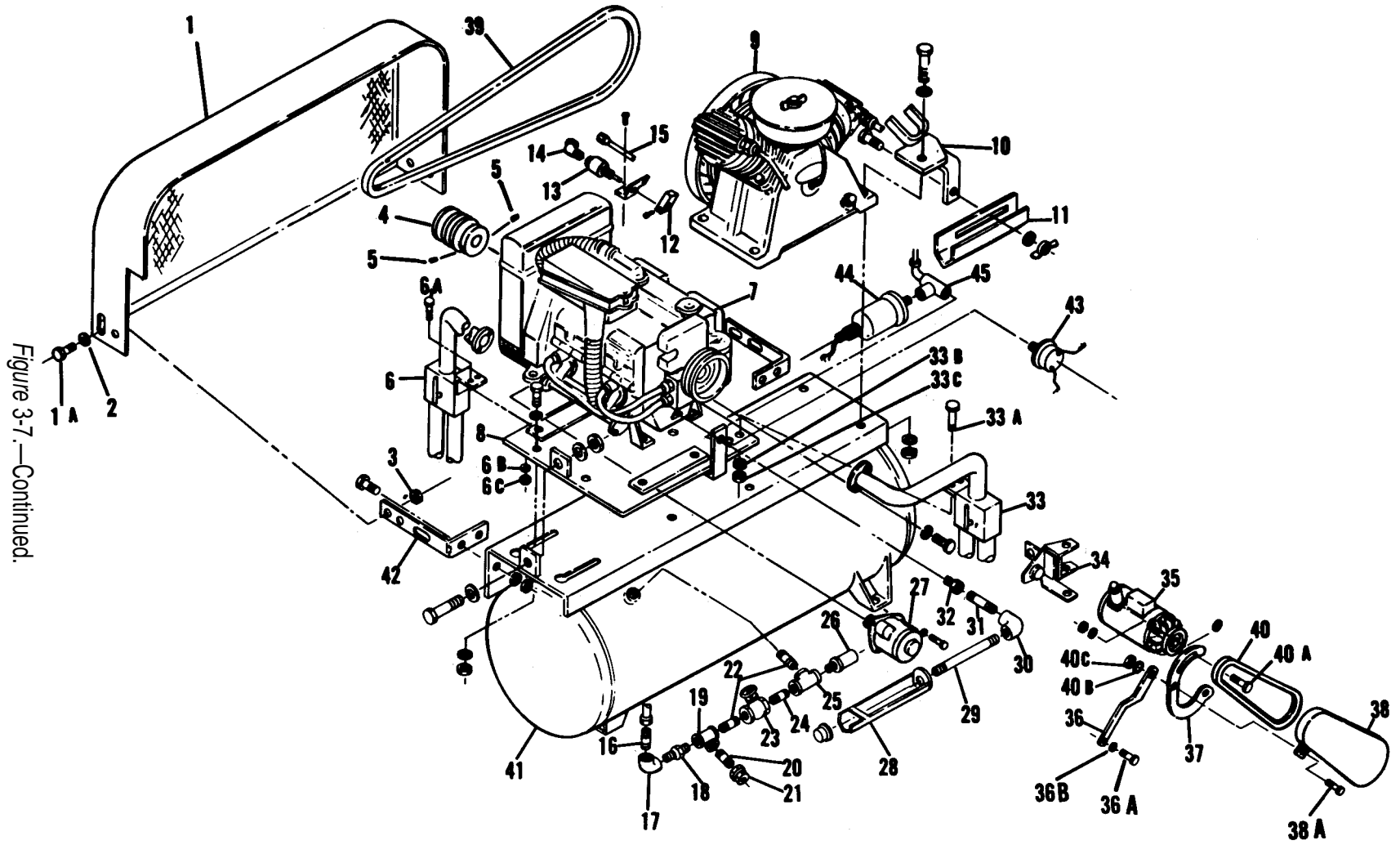

Figure 3-7.—Continued.

MEC 4930-217-14/3-7

## Section IX. FUEL SYSTEM

### 43. General

The fuel system consists of tanks, lines and fittings to support fuel flow to engine.

#### 3-44. Cap, Fuel Tank

*a. Removal.* Unscrew and remove tank cap to relieve pressure. Loosen clamp securing filler hose to tank, lift hose and remove strainer from tank.

*b. Installation.* Installation is the reverse of removal. Clean, inspect and replace strainer in tank reconnect hose and replace cap.

#### 3-45. Tank and Fuel Line

*a. Removal.* Remove tank (74 , fig. 3-68) by removing the hardware (71, 72, and 73), which attach the tank to the lubrication unit. Disconnect the fuel line which is connected from the fuel filter (supplied with the military standard engine) to the fuel tank. Remove the fuel line.

*b. Installation.* Install in reverse order of removal.

#### 3-46. Fuel Tank Drain Valve

*a. Removal.* Remove the fuel tank drain valve (81, g. 8-8) and elbow (82) by turning in a counterclockwise direction.

*b. Installation.* Install the drain valve in reverse of removal.

#### 3-47. Throttle Control

*a. Removal.*

(1) Disconnect the throttle cable from the throttle lever on the engine assembly.

(2) Remove the throttle control (106, fig. 3-8) by removing the retaining nut (110) holding the control handle at rear of control panel (98).

*b. Installation.*

(1) Install throttle control on control panel (98) by tightening nut (110).

1	High pressure hose reel	41	Hose assy	81	Fuel tank drain valve
2	Pneumatic hose reel	42	Fluid out hose (3)	82	Elbow
3	High pressure hose reel	43	Fitting (6)	83	Nipple
4	Gear oil hose reel	44	High pressure pump	84	Fuel line
5	Cap screw (20)	45	Low pressure pump	85	Elbow
6	Washer (20)	46	Gasket (3)	86	Air hose assy
7	Hose assembly (8)	47	Bushing (3)	87	Nipple
8	Air hose assembly	48	Elbow	88	Bushing
9	Swivel	49	Air pressure regulator	89	Bolt
10	Coupling	50	Fitting	90	Washer
11	Bushing (4)	51	Nipple	91	Nut
12	Low pressure control	52	Fitting	92	Engine and compressor assy
13	High pressure chassis control	53	Elbow	93	Air drain valve piping
14	Metering valve	54	Gauge	94	Mount
15	Straight swivel	55	Frame	95	Nut (8)
16	Pneumatic gun	56	Lubricant tank cover	96	Screw (8)
17	Engine oil hose reel	57	Nut (12)	97	Starwasher (8)
18	Hose assembly	58	Washer (12)	98	Panel
19	Elbow	59	Cap screw (12)	99	Nut (4)
20	Alcohol dispenser	60	Drain plug	100	Washer (4)
21	Fitting	61	Portable lubricator	101	Panel light (2)
22	Master air valve	62	Bracket	101A	Lamp (2)
23	Hose assembly	63	Retainer bar	102	Screw (4)
24	Elbow	64	Top drawer	103	Fuel gage
25	Manifold	65	Bottom drawer	104	Battery-generator indicator
26	Fitting	66	Air drain valve assy	105	Oil pressure gage
27	L. P. air hose assy (2)	67	Retainer bar	106	Throttle control
28	H. P. air hose assy	68	Battery drawer	107	Choke control
29	Cap screw (2)	69	Drawer frame	108	Nut
30	Nut (2)	70	Roller	109	Washer
31	Washer (2)	71	Nut (2)	110	Nut
32	H. P. hose assy (2)	72	Washer (2)	111	Washer
33	Elbow (2)	73	Cap screw (2)	112	Bracket
34	Coupling	74	Fuel tank	113	Cap screw (2)
35	Fitting	75	Fuel level sender	114	Washer (2)
36	Manifold	75A	Gasket	115	Ignition switch
37	Cap screw	76	Screw (6)	116	Bypass switch
38	Nut	77	Elbow	117	Starter switch
39	Washer	78	Elbow	118	Nut (6)
40	Tube (3)	79	Hose Clamp (2)	119	Washer (6)
		80	Fuel filler hose	120	Bracket (3)

Figure 3-8. Air lubrication system.

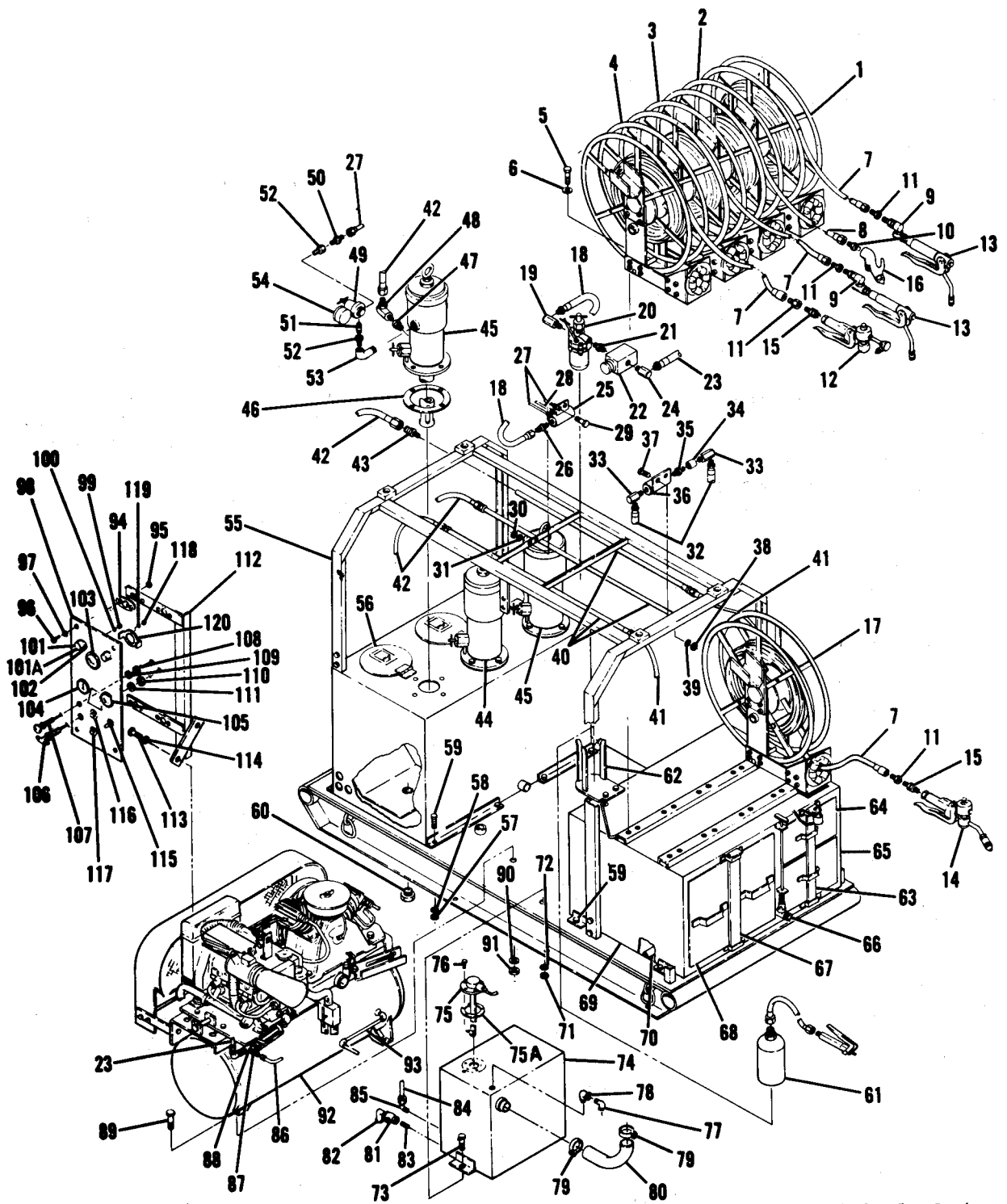

MEC 4930-217-14/3-8

Figure 3-8. —Continued.

(2) Place throttle lever on engine governor in desired position (TM 5-2805-203-14).

(3) Push throttle control handle on control panel all the way in. Connect the throttle cable to throttle on governor of engine. Adjust the throttle control cable to take up any slack which may exist between the control panel and the connecting location on the engine.

(4) Secure the throttle control handle.

### **3-48. Choke Control**

(Remove and install the choke control (107, fig. 3-8) in a similar manner to the throttle control, indicated in paragraph 3-47, using the choke control lever on the engine.

## **Section X. EXHAUST SYSTEM**

### **3-49. General**

The exhaust system consists of two exhaust diverters (6 and 83, fig. 3-7) which serve as mufflers and are connected directly to the engine exhaust system.

### **3-50. Exhaust Diverters**

#### *a. Removal.*

(1) Remove exhaust diverters (6 and 33, removal.

fig. 3-7) by removing the two each bolts from the engine exhaust outlets.

(2) Each diverter is attached to the mounting base (8) by two each cap screws, lockwashers and nuts (6A, 6B, 6C and 33A, 33B, and 33C) which must be removed to free the two exhaust diverters.

#### *b. Installation.* Installation is the reverse of

## **Section XI. DRIVE SHEAVE**

### **3-51. General**

The lubricating and servicing unit is equipped with a drive sheave which is connected onto the engine shaft by means of two set screws. The drive sheave serves as a pulley for the compressor drive belts.

### **3-52. Drive Sheave**

#### *a. Removal.*

(1) Remove the drive belt guard (1, fig. 3-7) as described in paragraph 3-93.

(2) Refer to paragraph 3-41 and remove the compressor drive belts (39).

(3) Loosen but do not remove the two set screws (5).

(4) Slide the drive sheave (4) away from the engine until it releases from the engine shaft.

#### *b. Cleaning and Inspection.*

(1) Cleaning the drive sheave thoroughly with an approved cleaning solvent and dry thoroughly.

(2) Inspect the drive sheave for cracks, burrs, or excessive wear.

(3) Replace an inoperative drive sheave.

*c. Installation.* Installation is the reverse of removal.

### **3-53. Drive Sheave Adjustment**

No adjustment is necessary other than belt alignment. Belts should drive slightly "OUT-OF-LINE". Loosen the set screws (5, fig. 3-7) to allow the sheave to slide on the engine shaft and align belts by moving the drive sheave in the desired direction. Retighten the set screws.

## **Section XII. ELECTRICAL SYSTEM**

### **3-54. General**

This section contains removal and installation instructions for the complete electrical system

and auxiliaries, with repair instructions for wiring assemblies, stop and clearance lights.

*Note.* Do not attempt to disconnect any electrical connections while the unit is operating. Disconnect the batteries.

### 3-55. Generator

#### *a. Removal.*

(1) Remove belt guard (38, fig. 3-7) by removing its attaching hardware. Remove belt adjusting hardware (40A, 40B, and 40C). This will release the drive belt (40) and the adjusting link (37) for removal.

(2) Remove support (36) by removing its attaching hardware.

(3) Remove generator (35).

*b. Installation.* Install the generator in reverse order of removal.

### 3-56. Voltage Regulator

*a. Removal.* The voltage regulator is located on the generator. Tag and disconnect electrical leads. Remove two sheet metal screws and remove regulator from generator.

*b. Installation.* Install the regulator in reverse of removal.

### 3-57. Starter

#### *a. Removal.*

(1) Refer to figure 3-7 for removal of starter (27).

(2) Tag and disconnect the starter electrical leads.

(3) Remove the starter from engine.

*b. Installation.* Install the starter in reverse of removal.

### 3-58. Starter Solenoid Switch

The starter solenoid switch is a part of the starter assembly. Refer to paragraph 3-57 for removal and installation of the starter assembly.

### 3-59. Battery-Generator Indicator, Oil Pressure Gage, and Fuel Level Gage

#### *a. Removal.*

(1) Tag and disconnect electrical leads on the battery-generator indicator (104, fig. 3-8). Remove the indicator by removing the bracket (120) located behind the panel (98) and hardware (118 and 119).

(2) Remove the oil pressure gage and fuel level gage in a similar manner.

*b. Installation.* Installation is the reverse of removal.

### 3-60. Panel light

#### *a. Removal.*

(1) Tag and disconnect electrical leads.

(2) Remove two each screws, lockwashers and nuts (102, 100, 99, fig. 3-8) and remove the panel lights (101).

*b. Installation.* Install the panel light in reverse of removal.

### 3-61. Switches

*a. Removal.* The bypass switch (116, fig. 3-8), start switch (117) and ignition switch (115) are all three installed and removed in the same manner. Tag and disconnect each switch electrically and remove the retaining nuts located on each switch on the front side of the panel.

*b. Installation.* Install the switches in reverse of removal.

### 3-62. Control Panel Wiring

*a. Removal and Installation.* Control panel wiring may be removed from its individual components at each connection by removing any attaching hardware. Wiring must be installed in accordance with the wiring diagram (fig 1-3).

*b. Repair.* Do not attempt to repair wiring other than replacing new terminal lugs to existing wire. Replace all defective wiring.

### 3-63. Control Panel

#### *a. Removal.*

(1) Tag and disconnect electrical leads to gauges, indicators and switches.

(2) Disconnect choke and throttle cables at the engine.

(3) Remove cap screw (113) and washer (114) and remove bracket (112) from engine and compressor assembly (92) with panel assembled to bracket.

(4) Remove panel from bracket by removing eight each screws (96), starwashers (97), nuts (95), and the four mounts (94).

*b. Installation.* Install the control panel in reverse of removal.

### 3-64. Blackout Stop and Taillight

*a. Removal.* Refer to figure 3-9 and remove the blackout taillights.

NOTE: TAG AND DISCONNECT ELECTRICAL LEADS AS NECESSARY

NOTE: REMOVE OTHER REFLECTORS, CLEARANCE LIGHTS, AND TAILLIGHTS IN A SIMILAR MANNER.

LAMP REPLACEMENT:

- STEP 1. REMOVE NECESSARY DOOR OR COVER MOUNTING SCREWS.
- STEP 2. REMOVE DOOR OR COVER, GASKET, AND DARK OR BURNED OUT LAMPS AS NECESSARY.
- STEP 3. REPLACE LAMPS, DOOR OR COVER, AND GASKET, AND SECURE WITH MOUNTING SCREWS.

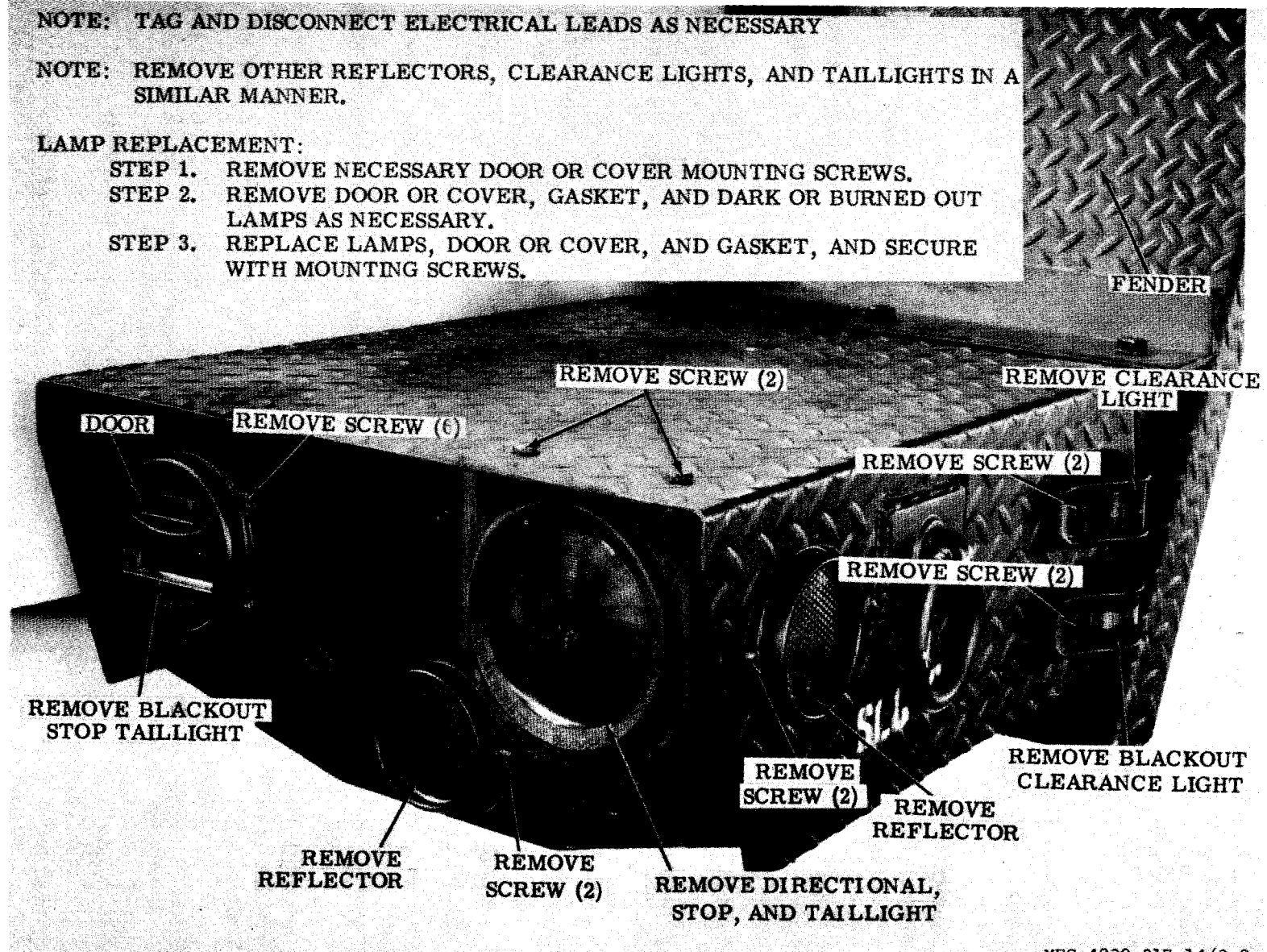

MEC 4930-217-14/3-9

Figure 3-9. Reflectors, clearance lights, blackout taillight, and directional stop and taillight—removal and installation.

b. *Disassembly.* Refer to figure 3-10 and disassemble the taillight.

c. *Cleaning, Inspection and Repair.*

(1) Clean all metal parts with an approved cleaning solvent and dry thoroughly.

(2) Inspect for cracks, breaks, corroded terminals, worn or frayed leads, and other damage.

(3) Replace a damaged or defective part.

d. *Reassembly.* Refer to figure 3-10 and reassemble the taillight.

e. *Installation.* Refer to figure 3-9 and install the taillight.

### 3-65. Stoplights-Directional and Tail, and Reflectors

a. *Removal.* Refer to figure 3-9 for removal of stoplights and reflectors.

b. *Cleaning and Inspection.*

(1) Clean all metal parts with any approved cleaning solvent and dry thoroughly.

(2) Inspect for cracks, breaks, corroded terminals, worn or frayed leads, and other damage.

(3) Replace a damaged or worn part.

c. *Installation.* Refer to figure 3-9 and install the stoplight and reflectors.

### 3-66. Trailer Clearance Lights

a. *Removal.* Refer to figure 3-9 and remove the trailer clearance lights and lamps.

b. *Disassembly.* Refer to figure 3-11 and disassemble the trailer clearance lights.

c. *Cleaning, Inspection, and Repair.*

(1) Clean all metal parts with an approved cleaning solvent and dry thoroughly.

(2) Inspect for cracks, breaks, worn or frayed leads, and other damage.

(3) Replace a damaged or defective part.

d. *Reassembly.* Refer to figure 3-11 and reassemble the trailer clearance lights.

e. *Installation.* Refer to figure 3-9 and install the trailer clearance lights.

### 3-67. Sender Units

a. *Removal.*

(1) Remove the fuel level sender (75, fig.

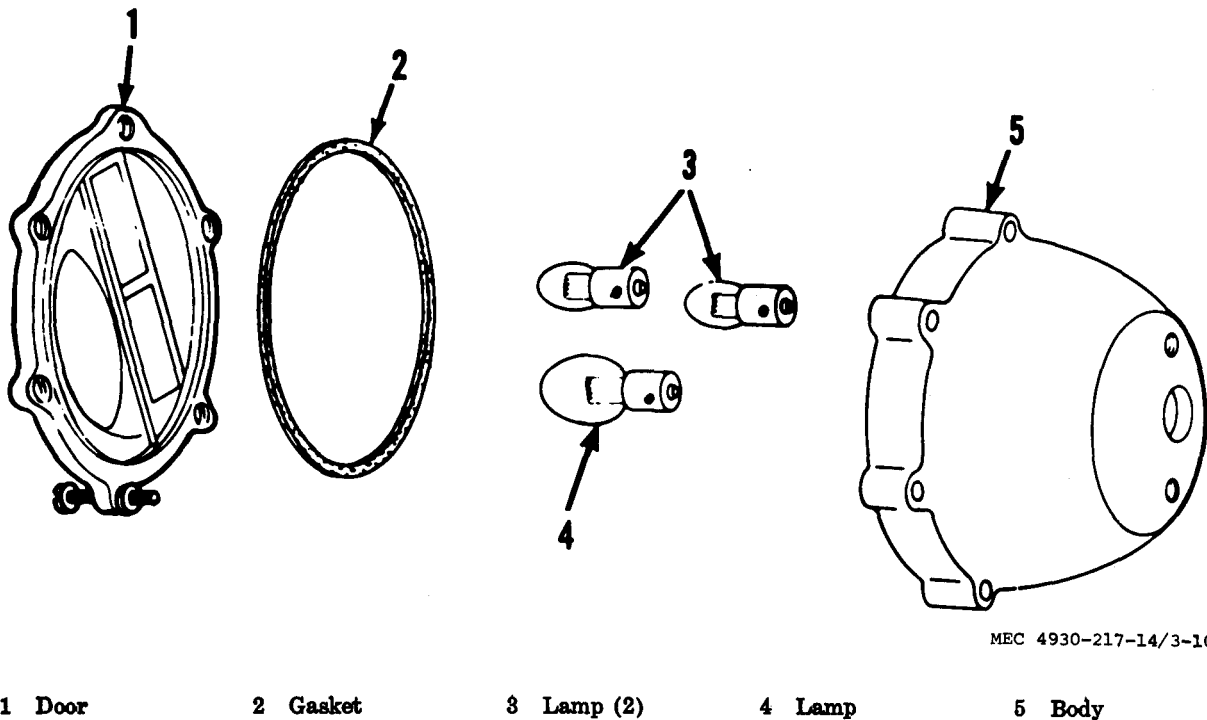

MEC 4930-217-14/3-10

1 Door

2 Gasket

3 Lamp (2)

4 Lamp

5 Body

Figure 3-10. Blackout, stoplight and taillight—disassembly and reassembly.



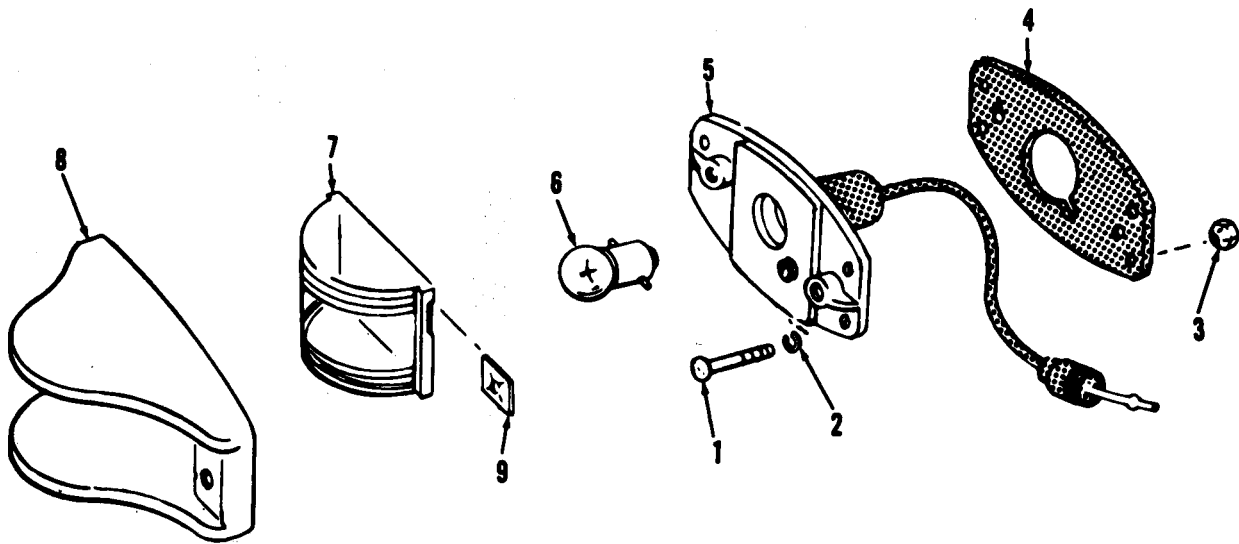

MEC 4930-217-14/3-11

1 Screw  
2 Lockwasher  
8 Nut

4 Felt  
5 Plate

6 Lamp  
7 Lens

8 Door  
9 Spring Nut

Figure 3-11. Trailer clearance lights-disassembly and reassembly.

3-8) by removing the six attaching screws (76), the ground lead and disconnecting the electrical leads. Remove the unit from the fuel tank (74, fig. 3-8). Tag electrical leads.

(2) Disconnect the electrical leads from the oil pressure transmitter (44, fig. 3-7) and unscrew the unit from tee (45). Tag electrical leads.

*b. Repair.* Do not attempt to repair the sender units. If they are malfunctioning, replace them.

*c. Installation.* Installation is the reverse of removal.

### 3-68. Safety Devices

#### *a. Removal.*

(1) The low oil pressure switch (43, fig. 3-7) can be removed by disconnecting the electrical leads and unscrewing from its mating part. Tag all electrical leads.

(2) The throttling device (13) can be removed as shown in figure 3-7. This cylinder assembly is an added safety device to prevent

over-pressurizing the unit should the other devices fail.

*b. Installation.* Installation is the reverse of removal.

### 3-69. Battery

*a. Removal.* Remove the two batteries (21, fig. 3-6) by removing cables (20, 22 and 23) and disconnecting the batteries from the battery box (19).

*b. Testing.* A battery test may be performed by checking the battery generator indicator on the front of control panel for proper charge of the battery.

*c. Installation.* Install the batteries in reverse of removal.

### 3-70. Chassis Wiring Harness and Receptacle

*a. Removal.* Refer to figure 3-12 for removal of the chassis wiring harness and receptacle.

*b. Installation.* Installation is the reverse of removal.

**NOTE: REMOVE HARNESS BY REMOVING HARNESS CLAMPS AND DISCONNECTING CONNECTORS TO LIGHTS AS REQUIRED.**

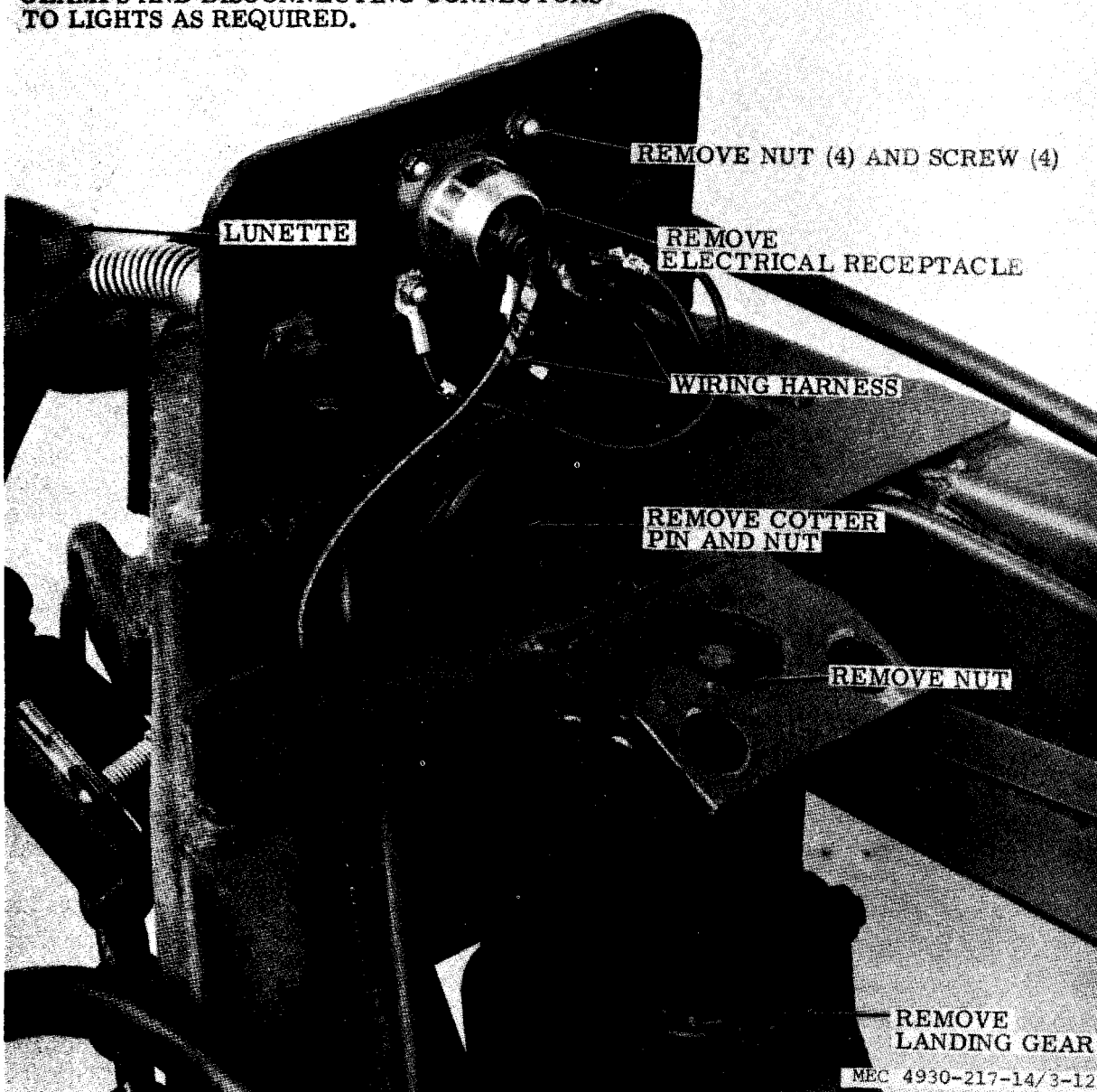

Figure 3-12. Landing gear, electrical receptacle, lunette and wiring harness-removal and installation.

### Section XIII. WHEELS, TIRES AND TUBES

#### 3-71. General

Each wheel hub is supported by two tapered roller bearings. A seal and hub cap protect the wheel bearings from dirt and foreign matter and retain the lubricate. The shock absorbers are two-way control, double-acting, hydraulic-cylinder units.

#### 3-72. Wheels

a. *Removal.* Refer to figure 3-13 and remove the wheels.

b. *Cleaning and Inspection.*

(1) Clean all metal parts with an approved cleaning solvent and dry thoroughly.

NOTE: BLOCK OPPOSITE WHEEL, USE A SUITABLE JACK AND RAISE WHEEL.

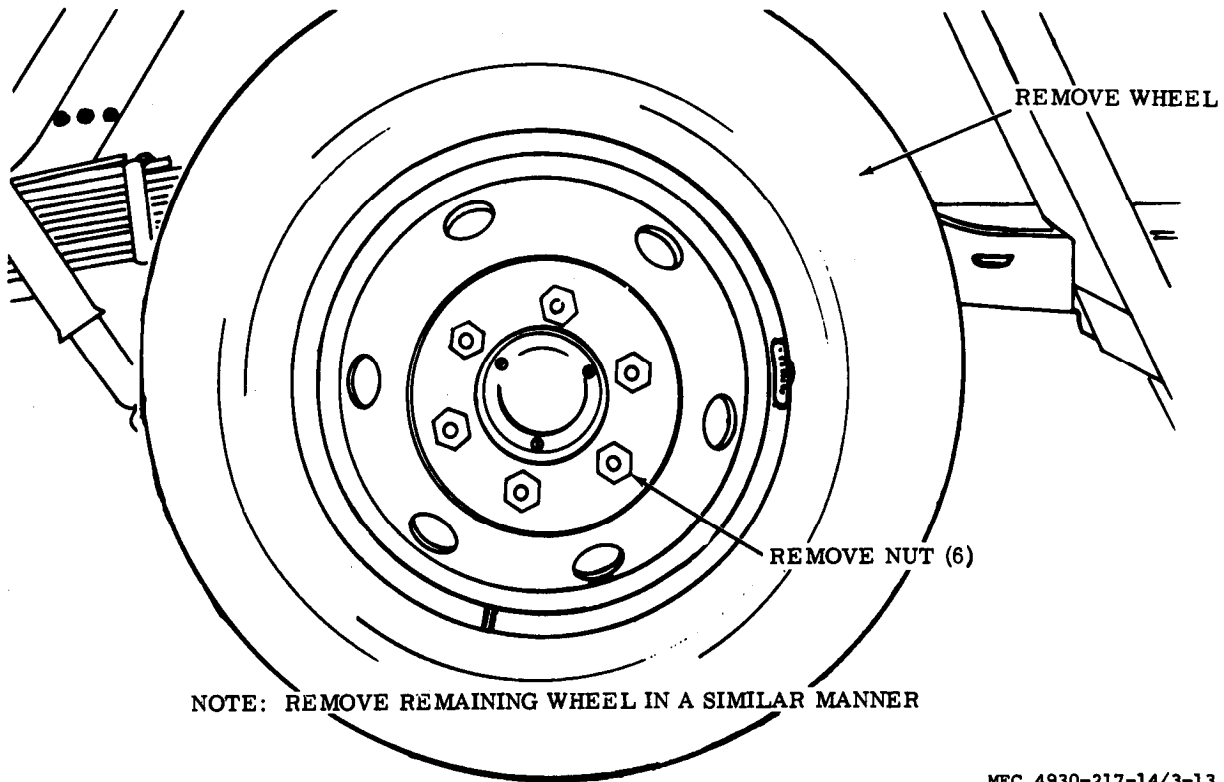

Figure 3-13. Wheels, removal and installation.

(2) Inspect for cracks, breaks, excessive wear, and other damage.

(3) Replace a damaged or defective wheel.

c. *Installation.* Refer to figure 3-13 and install the wheels.

### 3-73. Wheel Bearings, Hub and Brakedrum

#### a. *Removal and Disassembly.*

(1) Remove the wheels (para 3-72).

(2) Refer to figure 3-14 and remove and disassemble the wheel bearings, hub and brakedrum.

#### b. *Cleaning, Inspection and Repair.*

(1) Clean all parts with an approved cleaning solvent and dry thoroughly.

(2) Inspect for cracks, breaks, scoring, excessive wear, and other damage.

(3) Replace a damaged or defective part.

(4) Refer to LO 6-4930-217-12 and lubricate wheel bearings.

#### c. *Reassembly and Installation.*

(1) Refer to figure 3-14 and reassemble

and install the wheel bearings, hub and brakedrum.

(2) Install the wheels (para 3-72).

### 3-74. Tires and Tubes

#### a. *Removal.*

(1) Remove the wheels (3-72).

(2) Refer to TM 9-1870-1 and remove the tires and tubes.

#### b. *Cleaning and Inspection.*

(1) Clean the tires and tubes with a solution of warm water and soap.

(2) Inspect for cuts, cracks, breaks, and other damage.

(3) Replace a damaged or defective tire and tube.

#### c. *Installation.*

(1) Refer to TM 9-1870-1 and install the tires and tubes.

(2) Install the wheels (para 3-72).

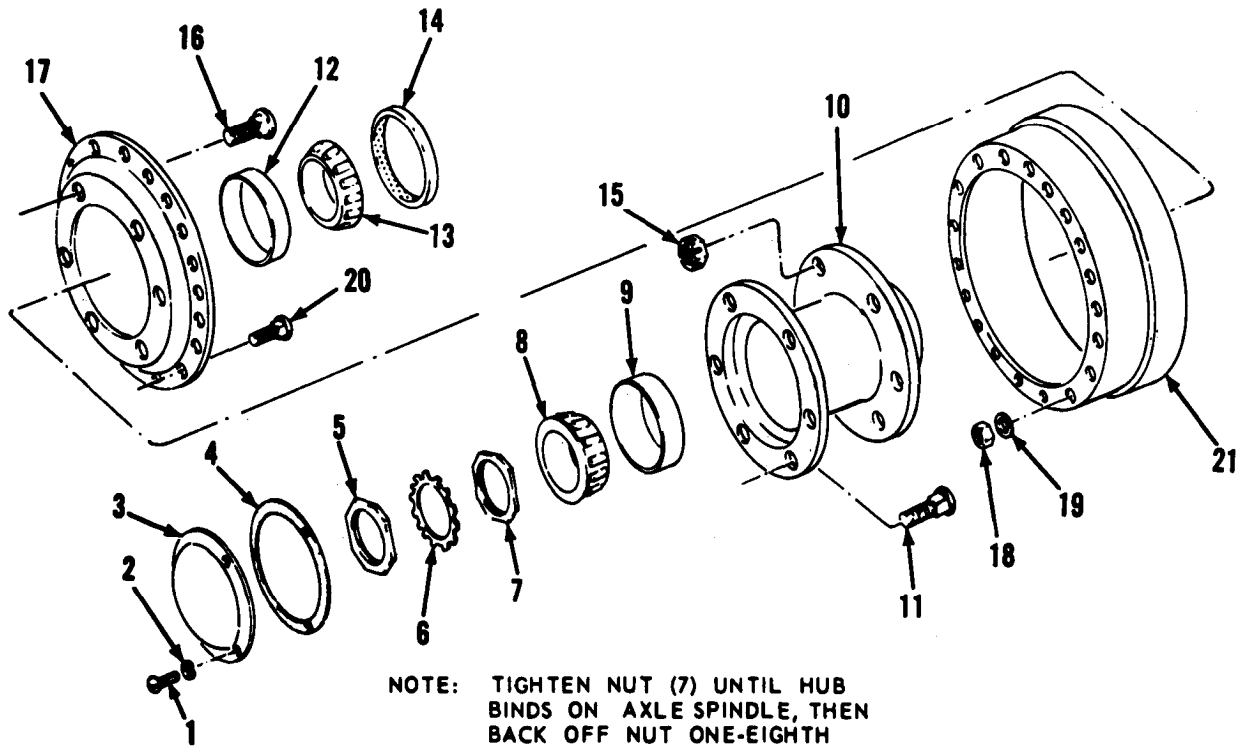

NOTE: TIGHTEN NUT (7) UNTIL HUB BINDS ON AXLE SPINDLE, THEN BACK OFF NUT ONE-EIGHTH TURN.

MEC 4930-217-14/3-14

- 1 Screw (3)
- 2 Washer (3)
- 3 Cap
- 4 Gasket
- 5 Nut
- 6 Lock
- 7 Nut

- 8 Cone
- 9 Cup
- 10 Hub
- 11 Stud
- 12 Cup
- 13 Cone
- 14 Seal

- 15 Nut (6)
- 16 Stud (6)
- 17 Plate
- 18 Nut (18)
- 19 Washer (18)
- 20 Screw (18)
- 21 Brake drum

Figure 3-14. Wheel bearings, hub and brakedrum-removal-disassembly, reassembly and installation.

#### Section XIV. SERVICE BRAKES, HYDRAULIC BRAKE SYSTEM, AND AIR BRAKE SYSTEM

##### 3-75. General

The brakeshoes are fitted with riveted lining. Each brakeshoe is anchored loosely to the backing plate so it can expand and contract without binding. Each wheel has two wheel cylinders secured to the backing plate. The wheel cylinders are actuated hydraulically to give an equal pressure to all brakeshoes. When compressed air is admitted to the brake chamber, the diaphragm push rod in the brake chamber actuates the master cylinder piston which furnishes hydraulic pressure to apply the brakes. The brake relay valve controls the trailer brakes and automatically applies the trailer brakes in event the trailer breaks away from

the towing vehicle. The air reservoir provides a supply of air for quick application.

##### 3-76. Service Brakes and Hydraulic Wheel Cylinders

###### a. Adjustment.

(1) Release air pressure by opening draincock on air reservoir.

(2) Jack the trailer and block it so the wheels can be turned by hand.

(3) Turn the lower adjusting stud (fig. 3-15) counterclockwise until brake linings contact brakedrum with slight drag when drum is rotated by hand. Then turn stud clockwise to allow drum to rotate freely.

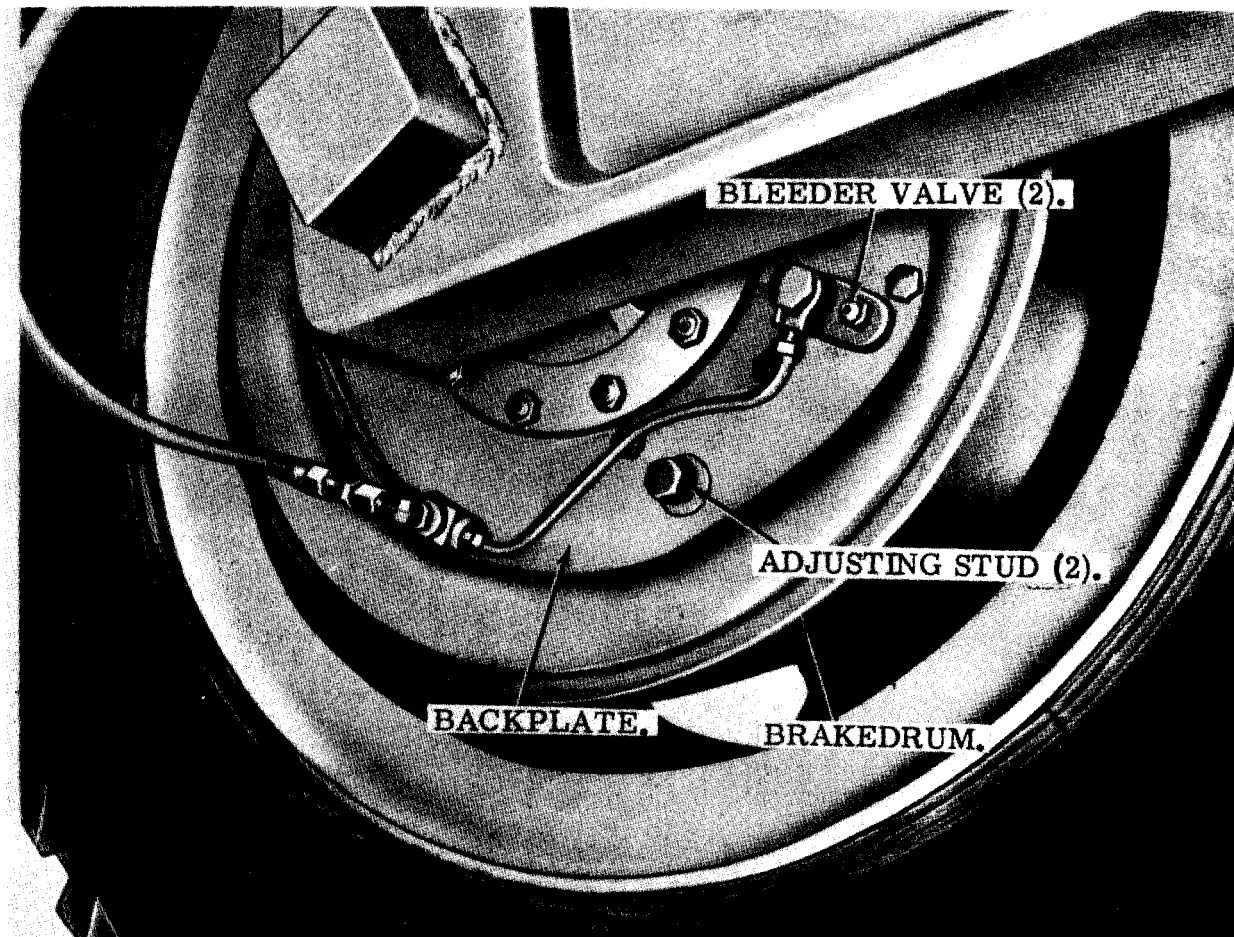

MEC 4930-217-14/3-15

Figure 3-15. Service brake adjustment and bleeding.

(4) Adjust the top adjusting stud in a similar manner.

(5) Adjust remaining wheel in a similar manner.

*b. Bleeding.*

(1) *General.* It is necessary to bleed air from hydraulic portion of service brakes if the system is opened or a component of the system has been replaced.

(2) *Manual Bleeding.*

(a) Connect trailer service brake hoses to a towing vehicle for manual bleeding as the brake pedal must be pressed and released to actuate the system. The master cylinder must be kept full of brake fluid or air will enter the system.

(b) Clean the bleeder valve with a clean

cloth. Attach a tube to the bleeder valve and place other end of tube in a suitable container.

(c) Fill the master cylinder with brake fluid. Refer to the current lubrication chart.

(d) Pump brake pedal on towing vehicle until pressure is applied. Hold pedal pressure and open bleeder valve (fig. 3-15) until pressure is released on pedal, then close valve.

(e) Repeat action until fluid has replaced air in system, then close valve; remove hose.

(f) Refill master cylinder with brake fluid and install filler cap.

(g) Repeat the above operation on the other wheel cylinders.

**Caution:** Maintain a high level of fluid in the master cylinder while bleeding each wheel cylinder.

*(3) Pressure feed filler bleeding.*

*(a)* Remove the filler cap from the master cylinder.

*(b)* Connect the hose to pressure feed filler, with the proper size adapter, to the opening of the master cylinder.

*(c)* The filler should contain from 10 to 20 psi air pressure and sufficient fluid to maintain constant fluid level in the master cylinder.

*(d)* Bleed the system as in manual bleeding (2 above)

*(e)* Replenish the fluid in the master cylinder after bleeding, if necessary. Refer to the LO 5-4930-217-12.

*c. Removal.*

(1) Remove the wheel hub and brake drum (para 3-73).

(2) Refer to figure 3-16 and remove the brakeshoes and wheel cylinders.

*d. Cleaning and Inspection.*

(1) Clean all metal parts with an approved cleaning solvent and dry thoroughly.

(2) Inspect for cracks, breaks, excessive wear and other damage.

(3) Replace a damaged or defective brake shoe, and return spring.

*e. Installation*

(1) Refer to figure 3-16 and install the brakeshoes and wheel cylinders.

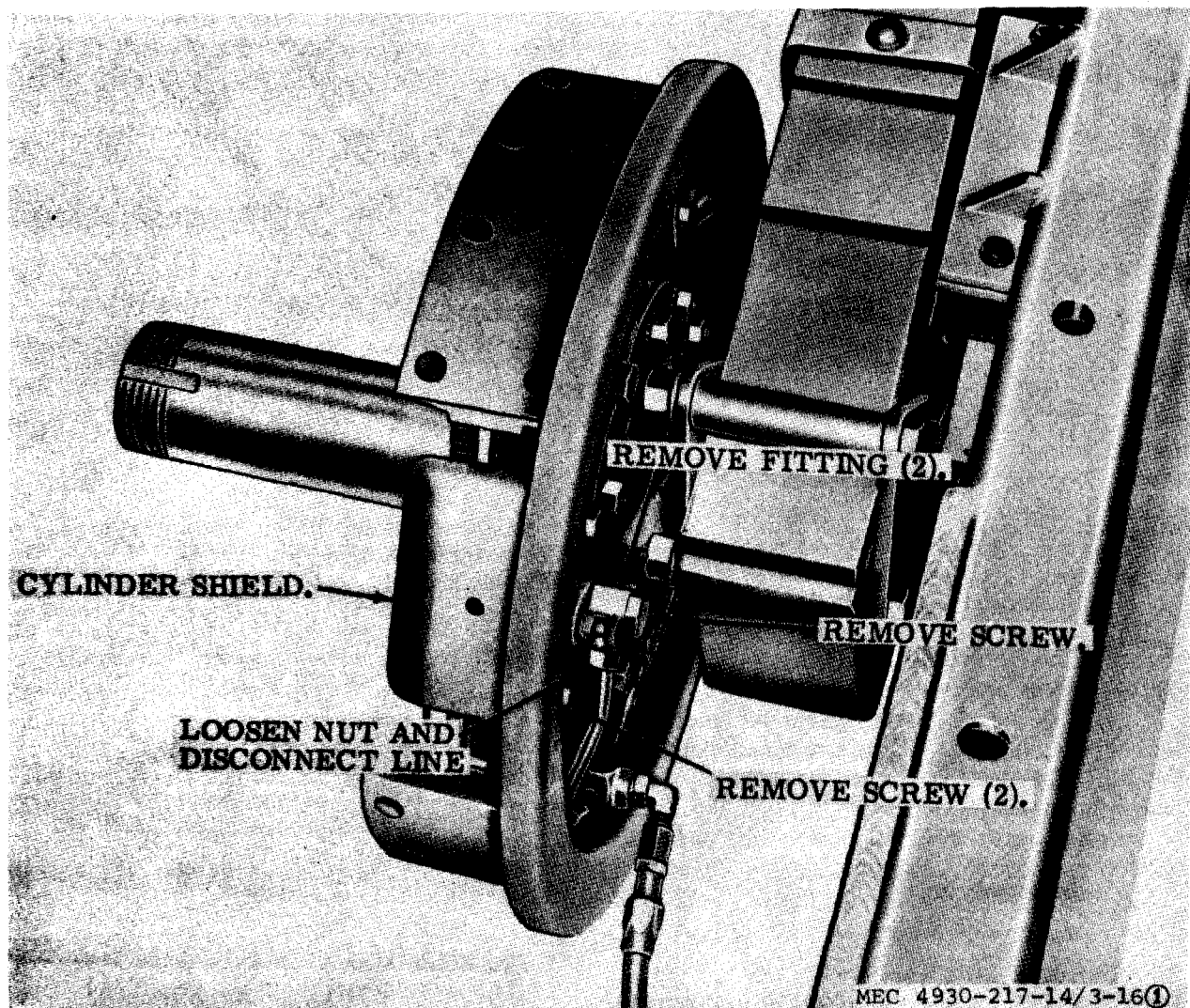

**Figure 3-16(1).** Wheel cylinders and brake shoe.  
removal and installation.



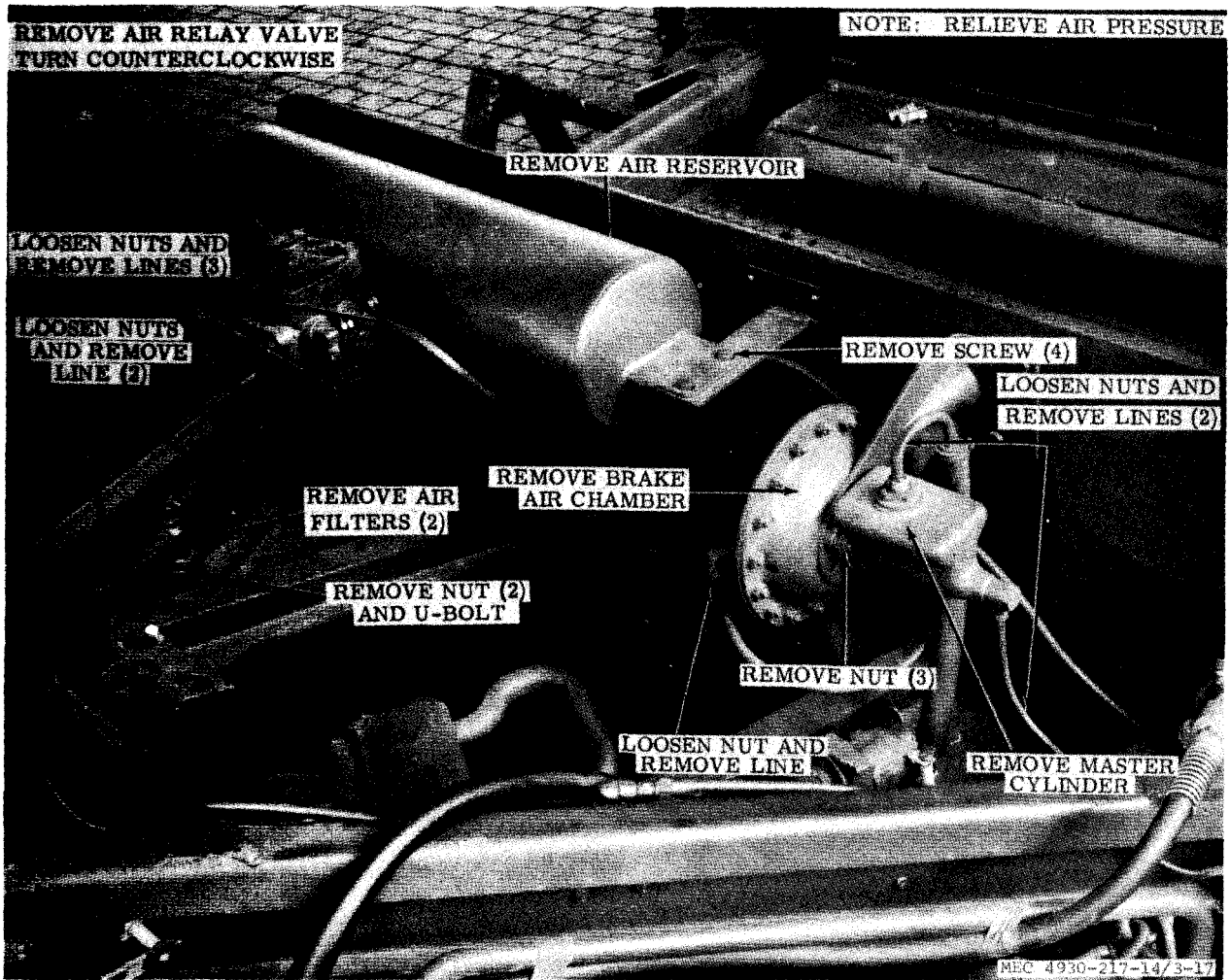
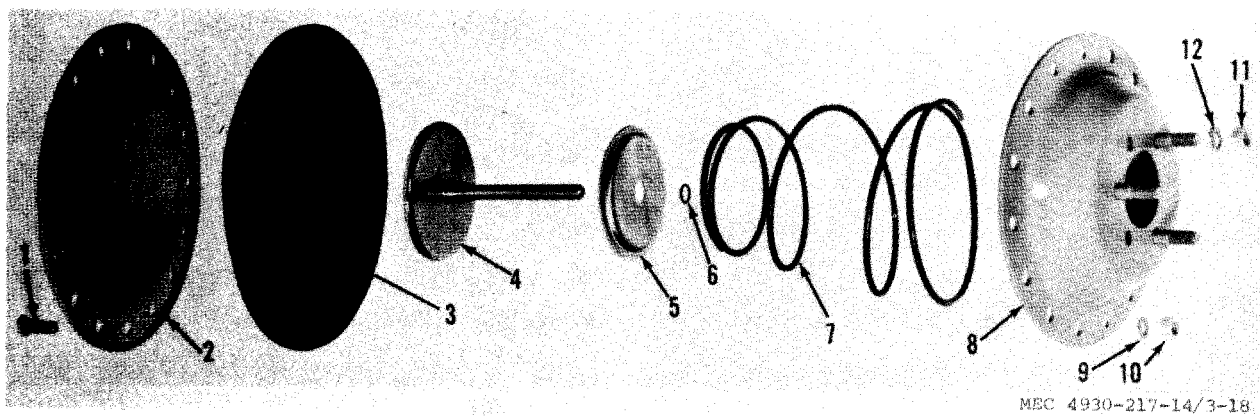

Figure 3-17. Air filters, air relay valve, air reservoir, brake air chamber, master cylinder, lines and fittings—removal and installation.



- |             |           |          |          |           |
|-------------|-----------|----------|----------|-----------|
| 1 Screw     | 4 Plate   | 7 Spring | 9 Washer | 11 Nut    |
| 2 Plate     | 5 Guide   | 8 Plate  | 10 Nut   | 12 Washer |
| 3 Diaphragm | 6 Grommet |          |          |           |

Figure 3-18. Brake air chamber-disassembly and reassembly.



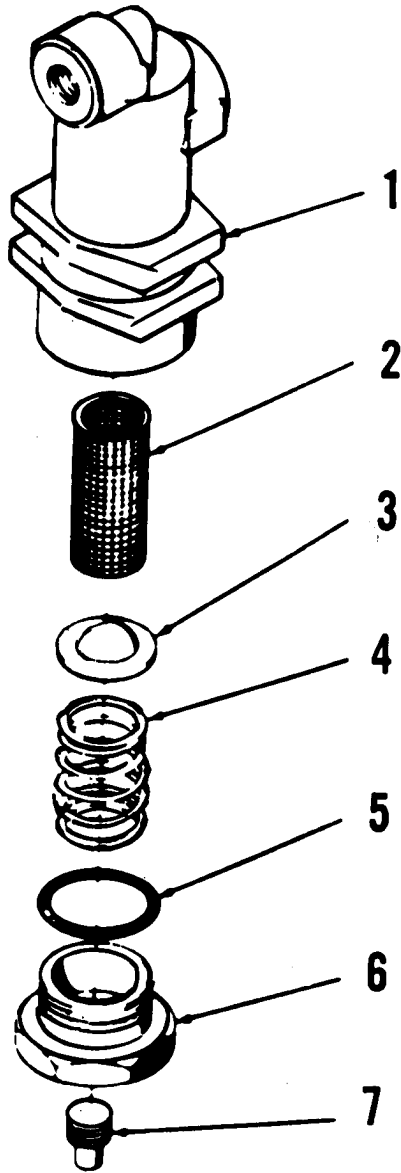

MEC 4930-217-14/3-19

- |           |                |
|-----------|----------------|
| 1 Housing | 5 Fiber washer |
| 2 Filter  | 6 Nut          |
| 3 Washer  | 7 End plug     |
| 4 Spring  |                |

Figure 3-19. Brake air filter assembly.

*b. Cleaning and Inspection.*

(1) Clean all metal parts with an approved cleaning solvent and dry thoroughly.

(2) Inspect for cracks, breaks, leaks, and other damage.

(3) Replace a damaged or defective relay valve.

*c. Installation.* Refer to figure 3-17 and install the relay valve.

**3-80 Air Reservoir**

*a. Removal.* Refer to figure 3-17 and remove the air reservoir.

*b. Cleaning and Inspection.*

(1) Clean the reservoir with an approved cleaning solvent and dry thoroughly.

(2) Inspect for cracks, breaks, leaks and other damage.

(3) Replace a damaged or defective air reservoir.

*c. Installation.* Refer to figure 3-17 and install the air reservoir.

**3-81. Air Filters**

*a. Removal.* Refer to figure 3-17 and remove the air filters.

*b. Disassembly and Reassembly.* The air filter may be disassembled and reassembled as shown in figure 3-19.

*c. Cleaning and Inspection.*

(1) Clean the air filters with an approved cleaning solvent and dry thoroughly.

(2) Inspect for cracks, breaks, leaks, and other damage.

(3) Replace a damaged or defective air filter.

*d. Installation.* Refer to figure 3-17 and install the air filter.

**Section XV. FRAME ASSEMBLY**

**3-82. General**

This section consists of the landing gear, fenders, lunette, and reflectors. The shock ab-

sorbers are two-way control, double-acting, hydraulic-cylinder units. This section contains information on the maintenance of these items.

### 3-83. Landing Gear

a. *Removal.* Refer to figure 3-12 and remove the landing gear.

b. *Disassembly.* Refer to figure 3-20 and disassemble the landing gear.

c. *Cleaning, Inspection and Repair.*

(1) Clean all parts with an approved cleaning solvent and dry thoroughly.

(2) Inspect for cracks, breaks, wear, scoring and other damage.

(3) Replace a damaged or defective part.

d. *Reassembly.* Refer to figure 3-20 and reassemble the landing gear.

e. *Installation.* Refer to figure 3-12 and install the landing gear.

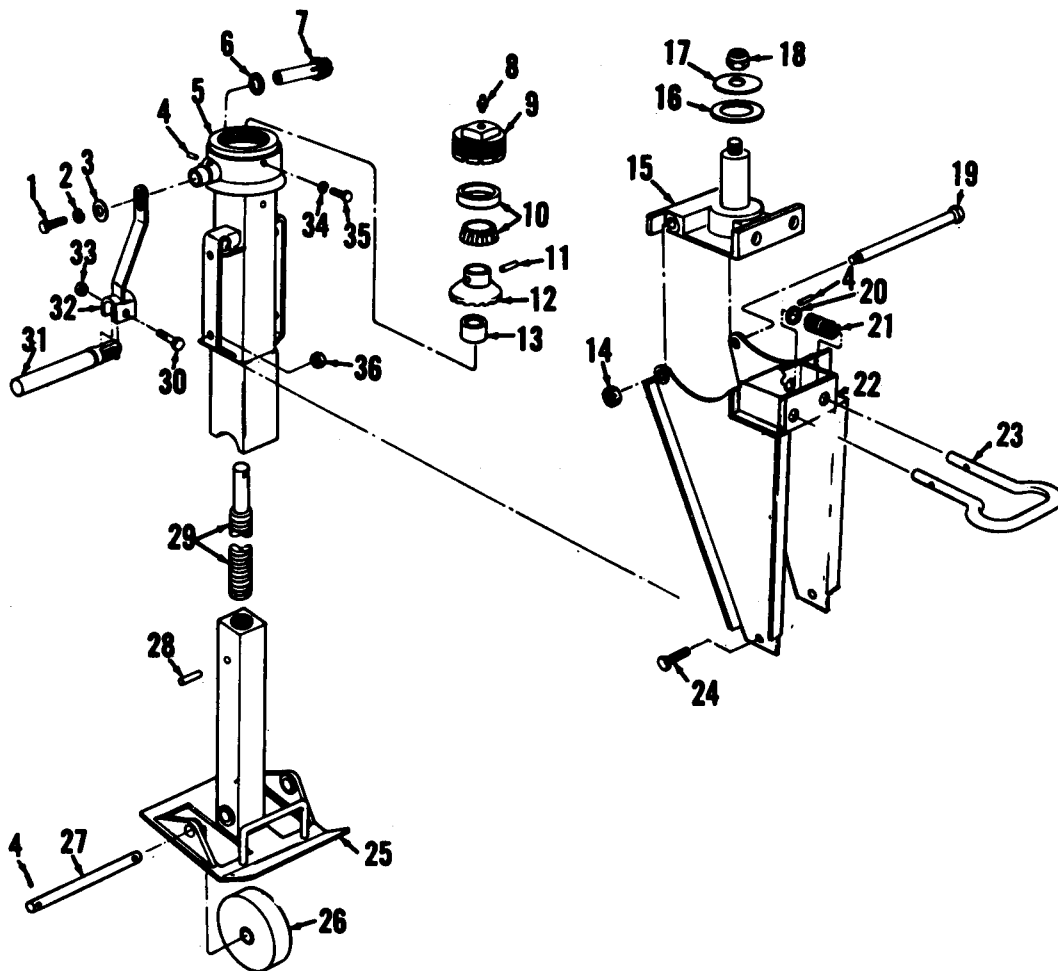

MEC 4930-217-14/3-20

1 Bolt	10 Bearing	19 Bolt	28 Pin
2 Washer	11 Pin	20 Washer	29 Screw
3 Washer	12 Gear	21 Spring	30 Screw
4 Pin	13 Spacer	22 Leg	31 Handle
5 Head assy	14 Nut	23 Handle	32 Arm
6 Washer	15 Swivel and spindle	24 Bolt	33 Nut
7 Gear	16 Washer	25 Tube and pad assy	34 Washer
8 Fitting	17 Washer	26 Wheel	35 Screw
9 Cap	18 Nut	27 Shaft	36 Nut

Figure 3-20. Landing gear-disassembly and reassembly.

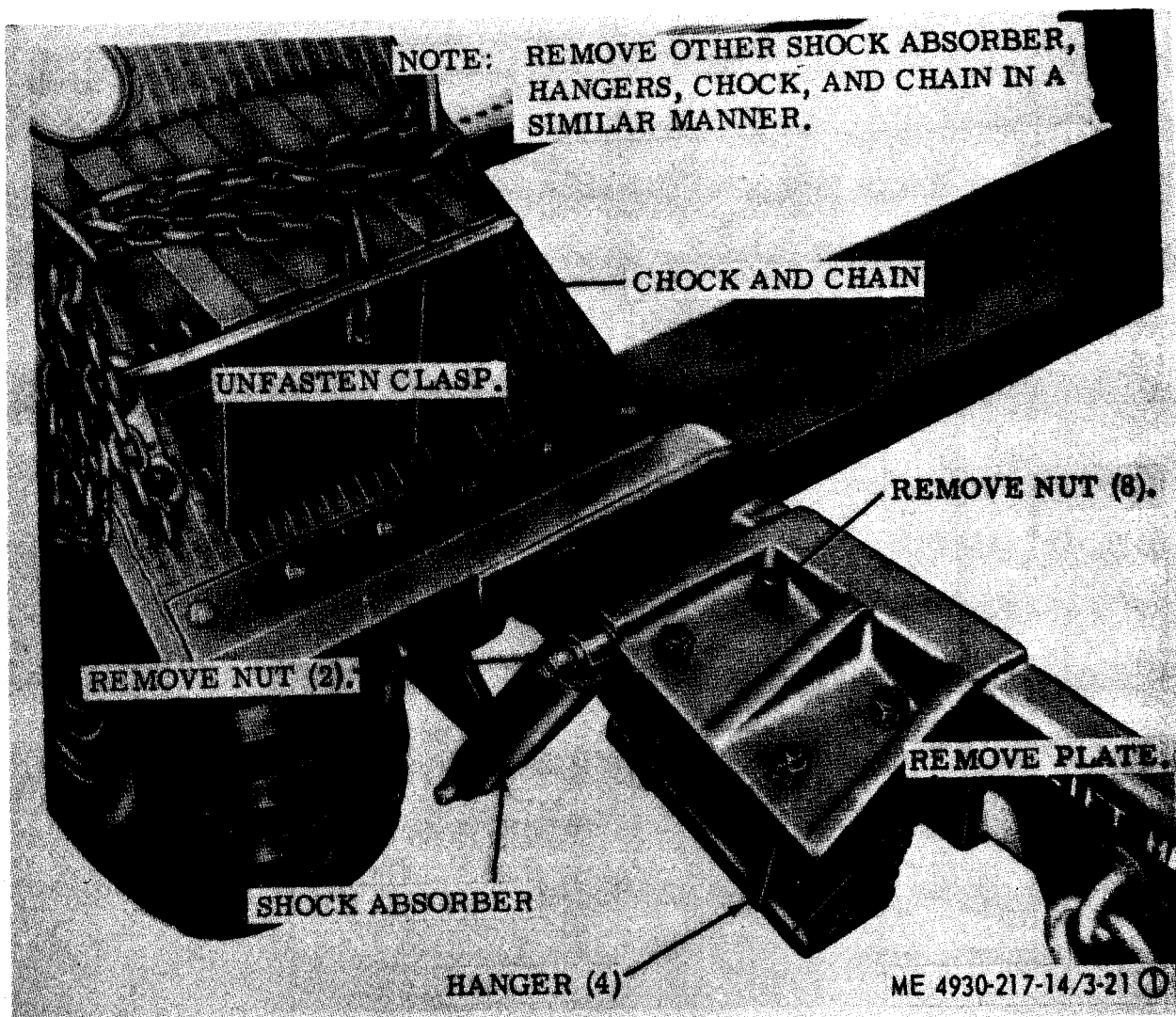

Figure 3-21①. Shock absorbers, hangers, springs, bumper and chocks, removal and installation.

### 3-84. Shock Absorbers

a. *Removal.* Refer to figure 3-21 and remove the shock absorbers.

b. *Cleaning and Inspection.*

(1) Clean the shock absorbers with an approved cleaning solvent and dry thoroughly.

(2) Inspect for cracks, breaks, dents, and other damage.

(3) Replace a damaged or defective shock absorber.

c. *Installation.* Refer to figure 3-21 and install the shock absorber.

### 3-85. Hangers and Springs

a. *Removal.*

(1) Remove the shock absorber (para 3-84).

(2) Refer to figure 3-21 and remove the hangers and springs.

b. *Cleaning and Inspection.*

(1) Clean all parts with an approved cleaning solvent and dry thoroughly.

(2) Inspect for cracks, breaks, and other damage.

(3) Replace a damaged or defective hanger and spring.

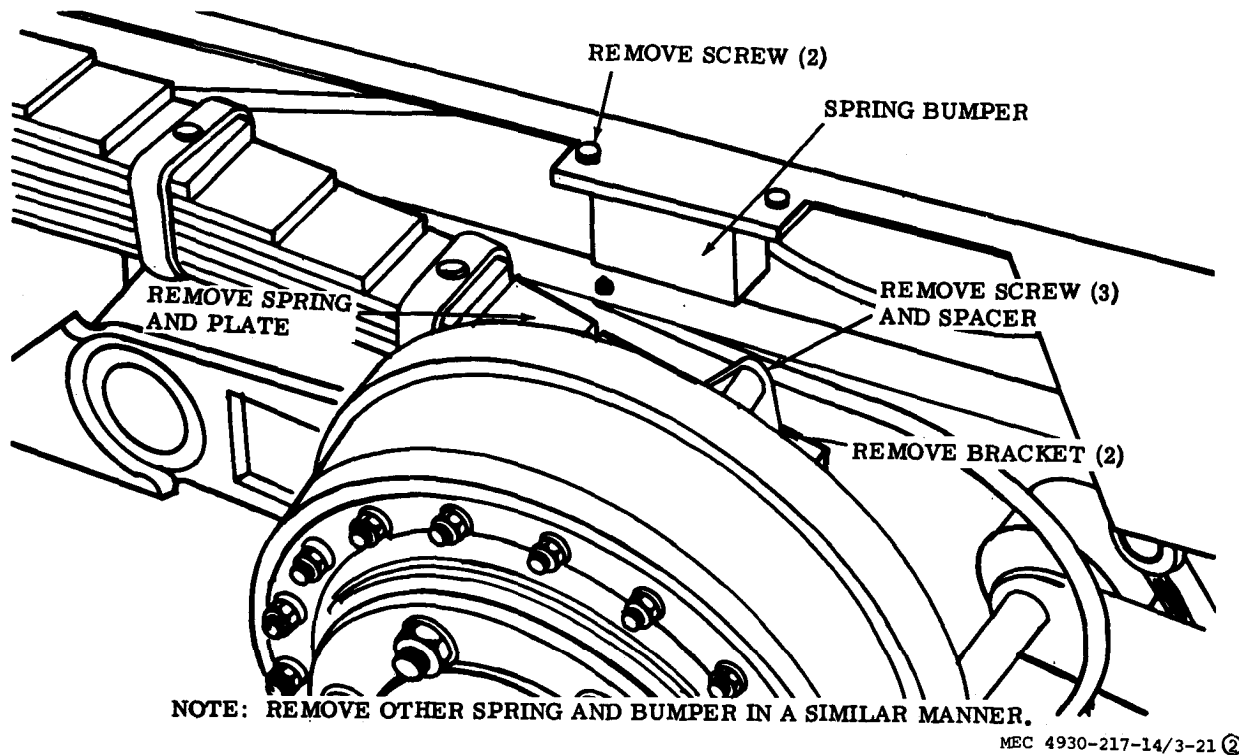

Figure 3-21 ② -Continued

*c. Installation.*

- (1) Refer to figure 3-21 and install the hangers and springs.
- (2) Install the shock absorbers (para 3-84).

**3-86. Spring Bumpers**

*a. Removal.* Refer to figure 3-21 and remove the spring bumpers.

*b. Cleaning and Inspection.*

- (1) Clean the bumpers with warm water and soap.
- (2) Inspect for cracks, breaks and deterioration.
- (3) Replace a damaged or defective spring bumper.

*c. Installation.* Refer to figure 3-21 and install the spring bumpers.

**3-87. Lunette**

*a. Removal.* Refer to figure 3-12 and remove the lunette.

*b. Cleaning and Inspection.*

- (1) Clean all parts with an approved cleaning solvent and dry thoroughly.
- (2) Inspect for cracks, breaks, damaged threaded parts, and other damage.
- (3) Replace a damaged or defective lunette and connector.

*c. Installation.* Refer to figure 3-12 and install the lunette.

**3-88. Wheel Chocks**

*a. Removal.* Refer to figure 3-21 and remove the wheel chocks.

*b. Disassembly.* Refer to figure 3-22 and disassemble the wheel chocks.

*c. Cleaning, Inspection and Repair.*

- (1) Clean all metal parts with an approved cleaning solvent and dry thoroughly. Clean the wooden blocks with a cloth.
- (2) Inspect for cracks, breaks, and other damage.
- (3) Replace a damaged or defective wheel chock.

d. *Reassembly.* Refer to figure 3-22 and reassemble the wheel chocks.

e. *Installation.* Refer to figure 3-21 and install the wheel chocks.

### 3-89. Fenders

#### a. *Removal.*

(1) Remove the clearance lights (para 3-66).

(2) Refer to figure 3-23 and remove the fenders.

#### b. *Cleaning and Inspection.*

(1) Clean all parts with an approved cleaning solvent and dry thoroughly.

(2) Inspect for cracks, breaks and other damage.

(3) Replace a damaged or defective fender.

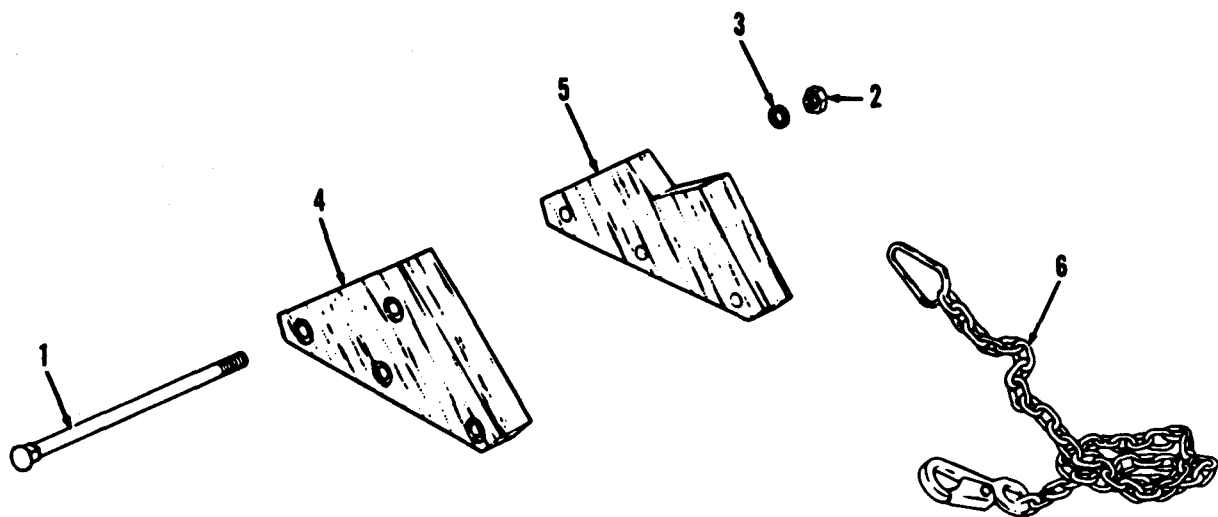

MEC 4930-217-14/3-22

1 Bolt

2 Nut

3 Washer

4 Block

5 Block

6 Chain

Figure 3-22. Wheel chocks, disassembly and reassembly.

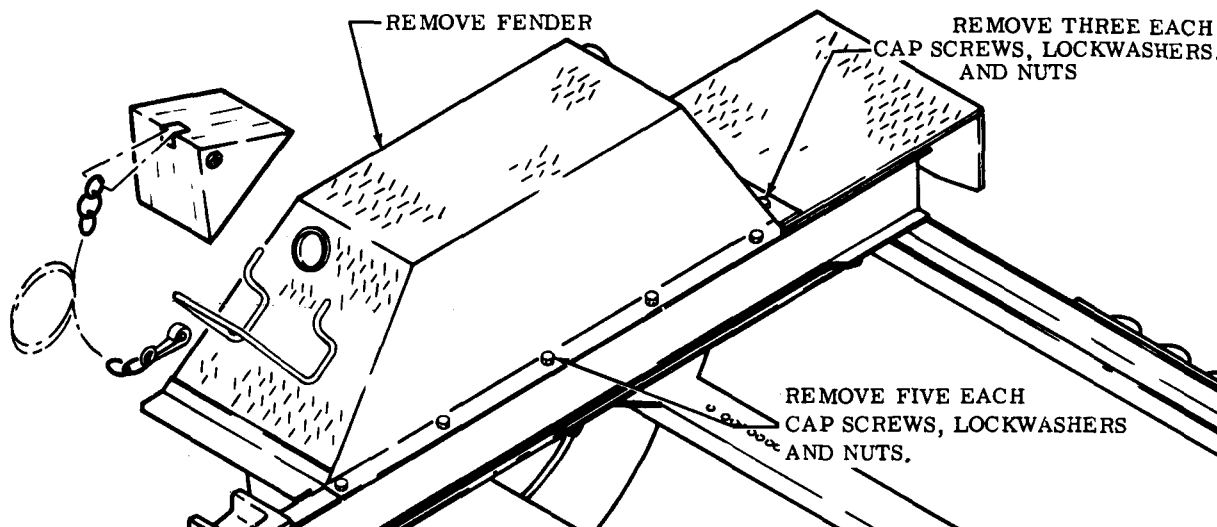

MEC 4930-217-14/3-23

Figure 3-23. Fenders—removal and installation.

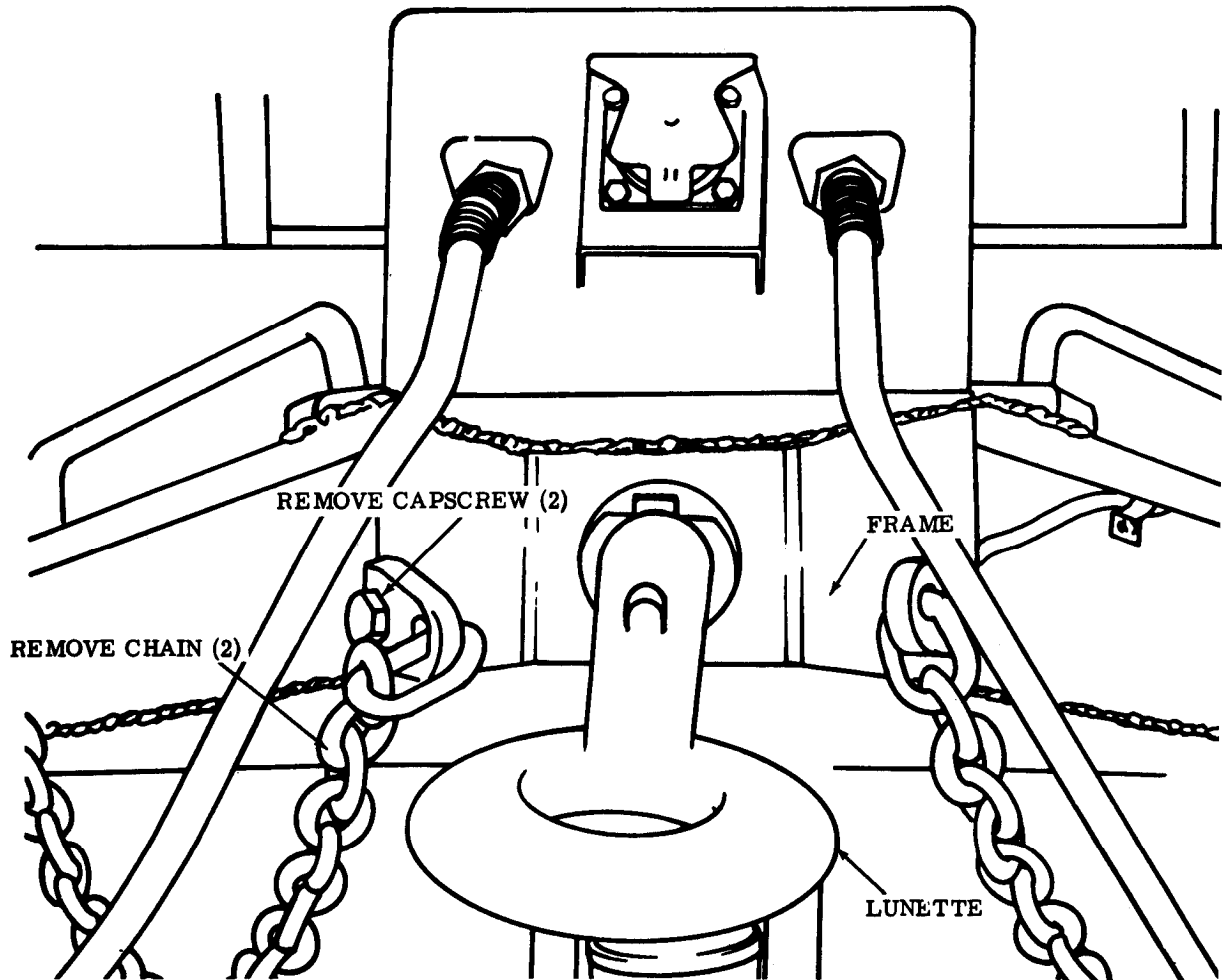

MEC 4930-217-14/3-24

Figure 3-24. Safety chains-removal and installation.

*c. Installation.*

(1) Refer to figure 3-23 and install the fenders.

(2) Install clearance lamps (para 3-66).

**3-90. Safety Chains**

*a. Removal.* Refer to figure 3-24 and remove the safety chains.

*b. Cleaning and Inspection.*

(1) Clean all parts with an approved cleaning solvent and dry thoroughly.

(2) Inspect for cracks, breaks and other damage.

*c. Installation.* Refer to figure 3-24 and install the safety chains.

**3-91. Intervehicular Hoses and Electrical Cable**

*a. Removal.*

(1) Disconnect the air hose assembly (2, fig. 3-25) from the hose bracket on the trailer chassis. Disconnect the electrical cable from the receptacle and remove the cable.

(2) Unscrew the air hose assembly from coupling (3) and remove connector assembly (6), tube assembly (7), coupling (3) and identification tags (4 and 5).

*b. Installation.* Install the intervehicular hose assemblies in reverse of removal. Each hose assembly is removed and installed in a similar manner. Connect the electrical cable assembly to the receptacle.

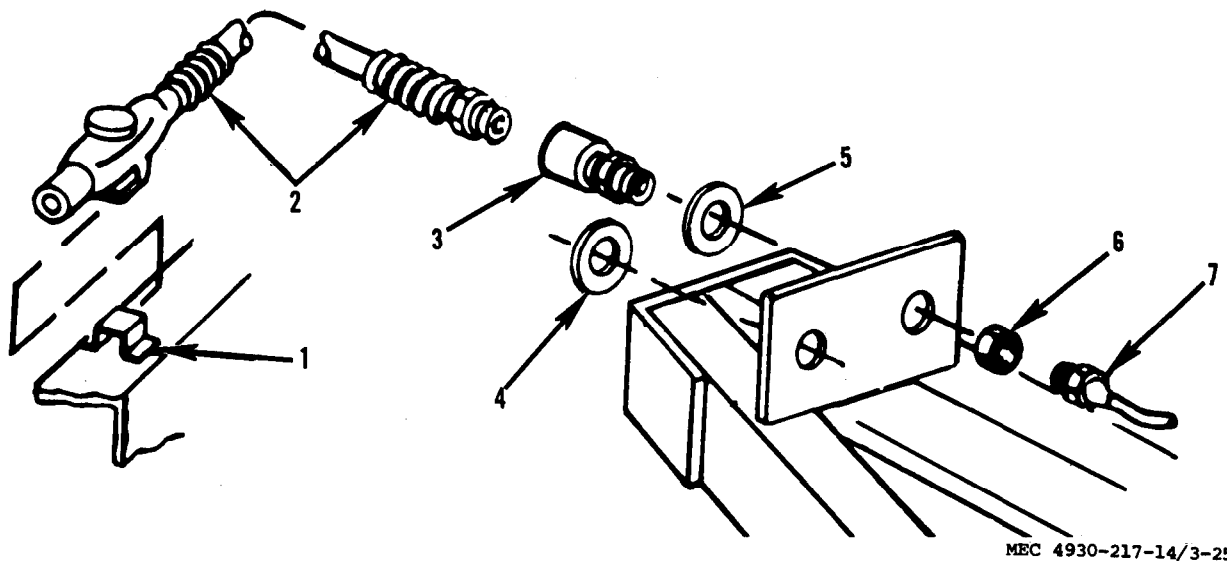

1 Bracket  
2 Hose assembly

3 Coupling  
4 Emergency tag

5 Service tag  
6 Connector assembly

7 Tube assembly

Figure 3-25. Intervehicular hose assembly.

## Section XVI. COMPRESSOR AND COMPONENTS

### 3-92. General

This section contains removal and installation information for the compressor, hoses, lines and fittings, drive belt and drive belt guard, compressor drive pulley and flywheel.

### 3-93. Compressor Drive Belt Guard

*a. Removal.* Remove the drive belt guard (1, fig. 3-7) by removing the four cap screws (1A), four flat washers (2) and four nuts (3). Lift the drive belt guard (1) up and over the engine-compressor assembly.

#### *b. Cleaning and Inspection.*

(1) Wipe the belt guard clean with a cloth moistened in dry cleaning solvent. Scrape off any accumulation of caked dirt or oil.

(2) Inspect the belt guard the dents or misalignment. Inspect attaching parts for crossed threads.

*c. Installation.* Installation is the reverse of removal.

### 3-94. Compressor Drive Belt

*a. Removal.* The compressor drive belt (39,

fig. 3-7) can be removed as described in paragraph 3-41.

#### *b. Cleaning and Inspection.*

(1) Inspect the compressor drive belts for excessive oil soaking, rips or worn and frayed spots. Replace belts if necessary. Belts are replaced as a set.

(2) Check belt tension. Proper tension is indicated when belts can be depressed approximately  $\frac{1}{2}$  to  $\frac{3}{4}$  inch.

*c. Installation.* Installation is the reverse of removal.

### 3-95. Compressor Flywheel and Pulley

#### *a. Removal.*

(1) Refer to paragraph 3-93 and remove the compressor drive belt guard.

(2) Refer to figure 3-26 and remove the flywheel and pulley.

#### *b. Cleaning and Inspection.*

(1) Clean the compressor flywheel and pulley with a cloth moistened in an approved dry cleaning solvent. Wipe dry and remove any oil or grease.

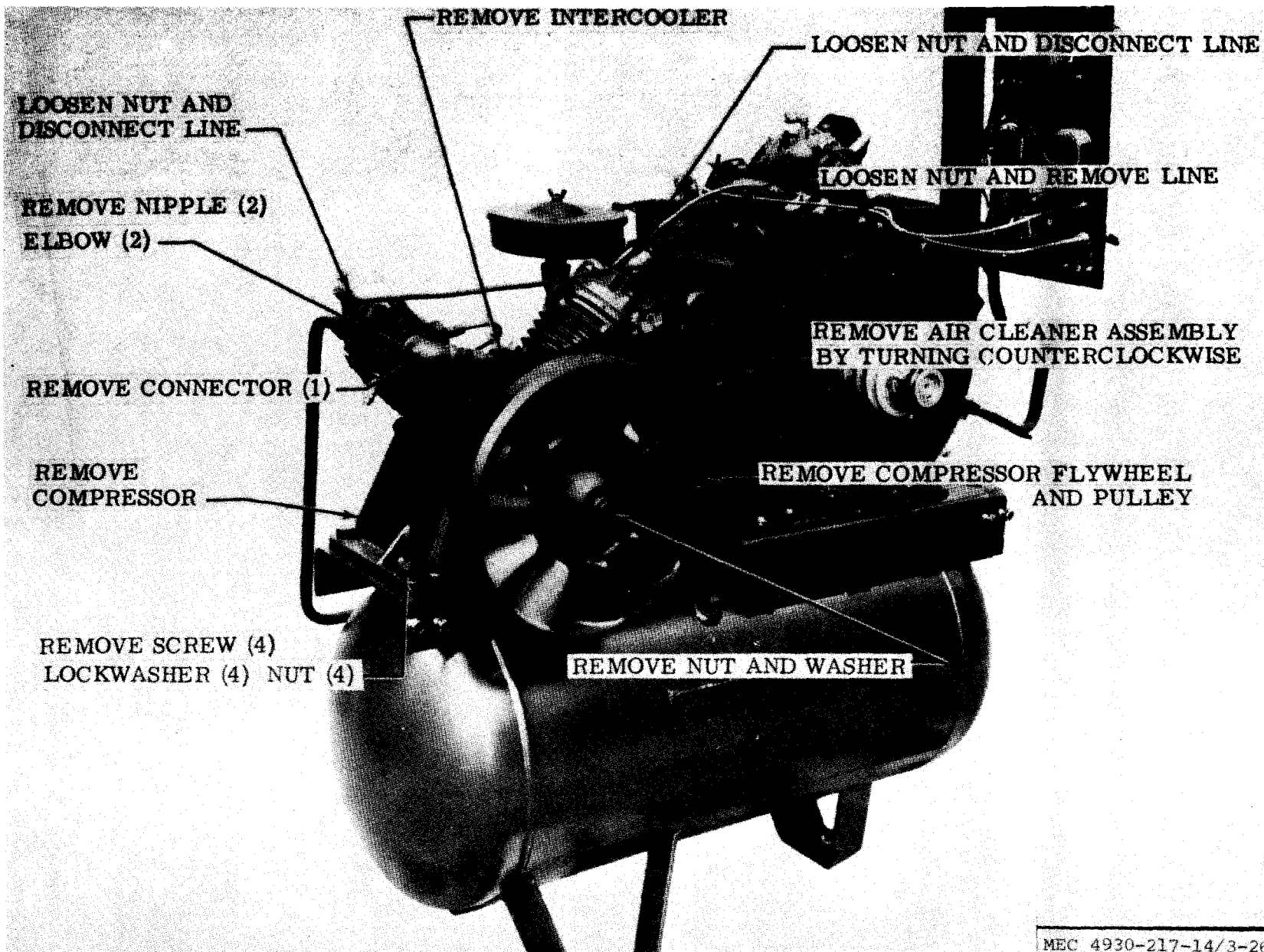
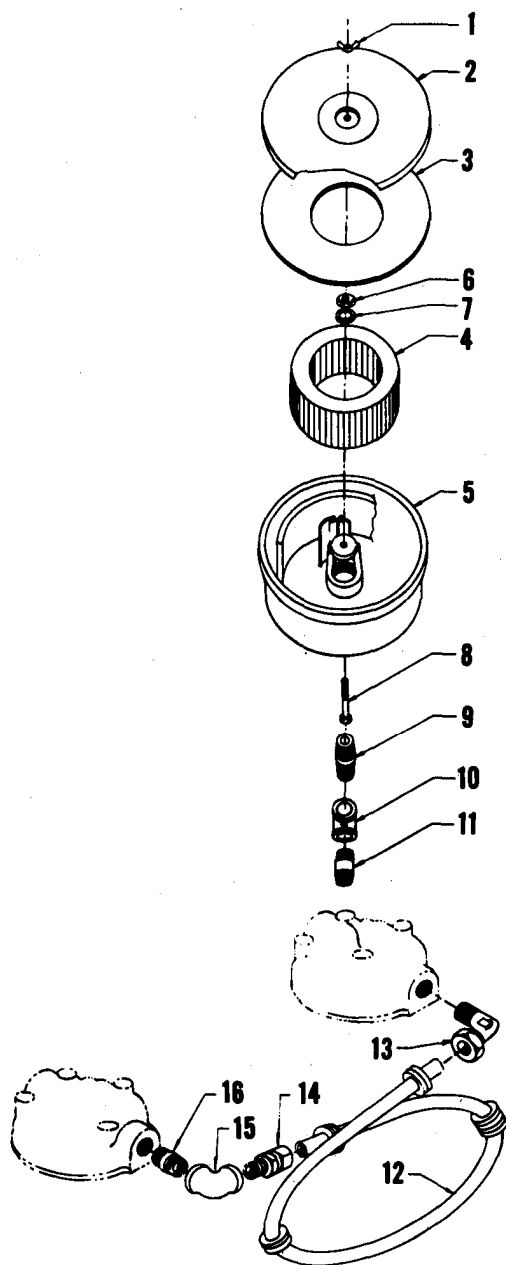

Figure 3-26. Compressor flywheel and pulley, intercooler and lines, removal and installation.





MEC 4930-217-14/3-27

- |                  |                 |
|------------------|-----------------|
| 1 Nut            | 9 Nipple        |
| 2 Cover          | 10 Elbow        |
| 3 Gasket         | 11 Nipple       |
| 4 Filter element | 12 Intercooler  |
| 5 Muffler body   | 13 Elbow, L. P. |
| 6 Nut            | 14 Connector    |
| 7 Washer         | 15 Elbow        |
| 8 Bolt           | 16 Nipple       |

Figure 3-27. Compressor air cleaner and disassembly and reassembly.

(2) Inspect the compressor flywheel pulley for cracks or burrs. Replace a defective flywheel pulley.

*c. Installation.* Install the flywheel pulley in reverse of removal. Do not force pulley on shaft. Be certain of alignment.

### 3-96. Intercooler and lines

*a. Removal.* Refer to figure 3-26, and remove the lines and intercooler.

*b. Disassembly and Reassembly.* Refer to figure 3-27 for disassembly and reassembly of intercooler.

*c. Inspection.*

(1) Inspect the lines and intercooler for cracks, burrs, excessive bends or other damage.

(2) Replace damaged or worn parts.

*d. Installation.* Refer to figure 3-26 and install the intercooler and lines.

### 3-97. Compressor

*a. Removal.*

(1) Refer to paragraph 3-93 and remove belt guard.

(2) Refer to paragraph 3-41 and remove the drive belts.

(3) Refer to figure 3-26 and remove compressor.

*b. Inspection.*

(1) Perform a thorough general inspection of all parts of the compressor assembly, checking particularly for cracked and chipped castings, damaged screw threads, and finished surfaces that are scored, pitted, or scratched.

(2) Inspect connecting tube assemblies and fittings for worn or damaged screw threads, cracks, dents, sharp bends, and other defects. Pay particular attention to the flare ends of the tubes since cracking is most apt to occur at the root of the flare. Do not attempt to reclaim a connecting tube assembly by replacing component parts.

*c. Installation.*

(1) Refer to figure 3-26 and carefully install compressor.

(2) Refer to paragraph 3-41 and install compressor drive belt.

(3) Refer to paragraph 3-93 and install belt guard.

### 3-98. Compressor Air Cleaner Assembly

*a. Removal.* Refer to figure 3-26 and remove the air cleaner assembly.

*b. Disassembly and Reassembly.* Refer to figure 3-27 for disassembly and reassembly of the air cleaner assembly.

*c. Installation.* Refer to figure 3-26 and install the air cleaner assembly.

### 3-99. Compressor Oil Drain Plug

*a. Removal and Installation.* Remove and install compressor drain plug as shown in figure 3-4.

*b. Inspection.* Inspect the plug for excessive damage or cross threads. Replace the plug.

## Section XVII. HOSE REEL ASSEMBLIES AND CONTROLS (Used only on Serial Numbers 69-29737 thru 69-29942)

### 3-100. General

The hose reel bank consists of five reels and hoses mounted on a common base. Four of the hoses are used to dispense chassis, gear and engine oil. One hose is used for dispensing air with a lock to prevent hoses from unreeling.

### 3-101. Chassis, Gear and Engine Oil Reels

*a. Removal.* Disconnect hoses from tubes (40, fig. 3-8) and manifold (96). Remove four each screws (5) and washers (6) and remove reel assembly (4). All reels are removed in a similar manner.

*Note.* Disconnect hoses slowly to relieve any excess lubricant buildup in lines.

*b. Installation.* Installation is the reverse of removal. Refer to figure 8-8 as an aid to installation.

### 3-102. High Pressure Chassis Control

*a. General.* The high pressure chassis control provides a means of controlling the amount of grease expended from the lubricating unit.

*b. Removal.* Remove the high pressure chassis control (13, fig. 8-8) and the swivel (9) from the hose assembly (7).

*c. Disassembly.* Disassemble the high pressure chassis control in the numerical sequence of figure 3-28.

*d. Cleaning.*

(1) Clean all parts in an approved cleaning solvent.

(2) Inspect all components for cracks or other defects. Replace if defective.

(3) Inspect all threaded surfaces for stripped or cross threads. If beyond repair, replace.

*e. Repair.*

(1) To adjust trigger, loosen lock nut (4) and back out set screws (3) approximately  $\frac{1}{4}$  turn or until handle has  $\frac{1}{2}$  in. travel.

(2) To replace ball seat insert (13) and ball (15), perform the following:

(a) Place handle in vise, then unscrew hand grip (19) from body and remove spring (17).

(b) Tap out ball (15), ball guide (16) and ball seat insert (13).

(c) Replace ball seat insert (13) and ball (15). Clean handle thoroughly and reassemble making sure new gaskets are placed in proper position before hand grip is replaced.

(3) To replace V-Packing (11) perform the following:

(a) Place handle in vise and unscrew lance (2) from body (12).

(b) Remove retaining ring (6) and trigger pin (7).

(c) Unscrew packing screw (9) and pull out V-packing (11) with a small hook.

(d) Replace packing, packing nut and valve stem.

*Note.* Do not tighten packing nut until valve stem has been replaced.

(e) Replace trigger, pin and lance. Adjust trigger and handle is ready for use.

*f. Reassembly.* Reassemble in reverse order of disassembly.

*g. Installation.* Installation is essentially the reverse of removal.

### 3-103. Low Pressure Control Handle

*a. Removal.* Remove the low pressure control by unscrewing the hose swivel from the adapter. With the low pressure control pointed

1 Chuck	8 Stem	15 Ball	22 Body
2 Lance	9 screw	16 Ball guide	23 Stem
3 Set screw	10 Washer	17 spring	24 Nut
4 Lock nut	11 V-packing	18 Washer	25 Packing
5 Handle	12 Body	19 Handgrip	26 Spacer
6 Retaining ring	13 Ball seat insert	20 stem	27 Ball
7 Pin	14 Gasket	21 Body	

Figure 3-28. High pressure chassis control (used only on Serial Numbers 69-29787 through 69-29942) .

away from you, turn bushing (11, fig. 3-8) counterclockwise until the low pressure control is removed from hose (7).

*b. Disassembly.* Disassemble low pressure chassis control as illustrated in figure 3-29.

*c. Cleaning and Inspection.*

(1) Clean all parts in an approved cleaning solvent.

(2) Inspect all components for cracks or other defects. Replace if defective.

(3) Inspect all threaded surfaces for stripped or cross threads. If beyond repair, replace.

*d. Repair (fig. 3-29).*

(1) To adjust trigger to  $\frac{1}{16}$  in play, turn retainer (18) clockwise to tighten, counter-

clockwise to loosen until trigger has proper play. Retainer (18) contains valve components retainer ring (19), spring (21 ) and valve (22). By adjusting the retainer, you increase or decrease the room the valve stem (23) has to move.

(2) To replace valve (22), assemble valve, spring (21 ), washer (20), retainer ring (19) into retainer (18) and screw the assembly into body (14).

*Note.* Check adjustment after assembly. Trigger shall be adjusted to  $\frac{1}{16}$  inch play.

*e. Reassembly.* Reassemble by reversing disassembly procedure.

*f. Installation.* Installation is the reverse of removal.

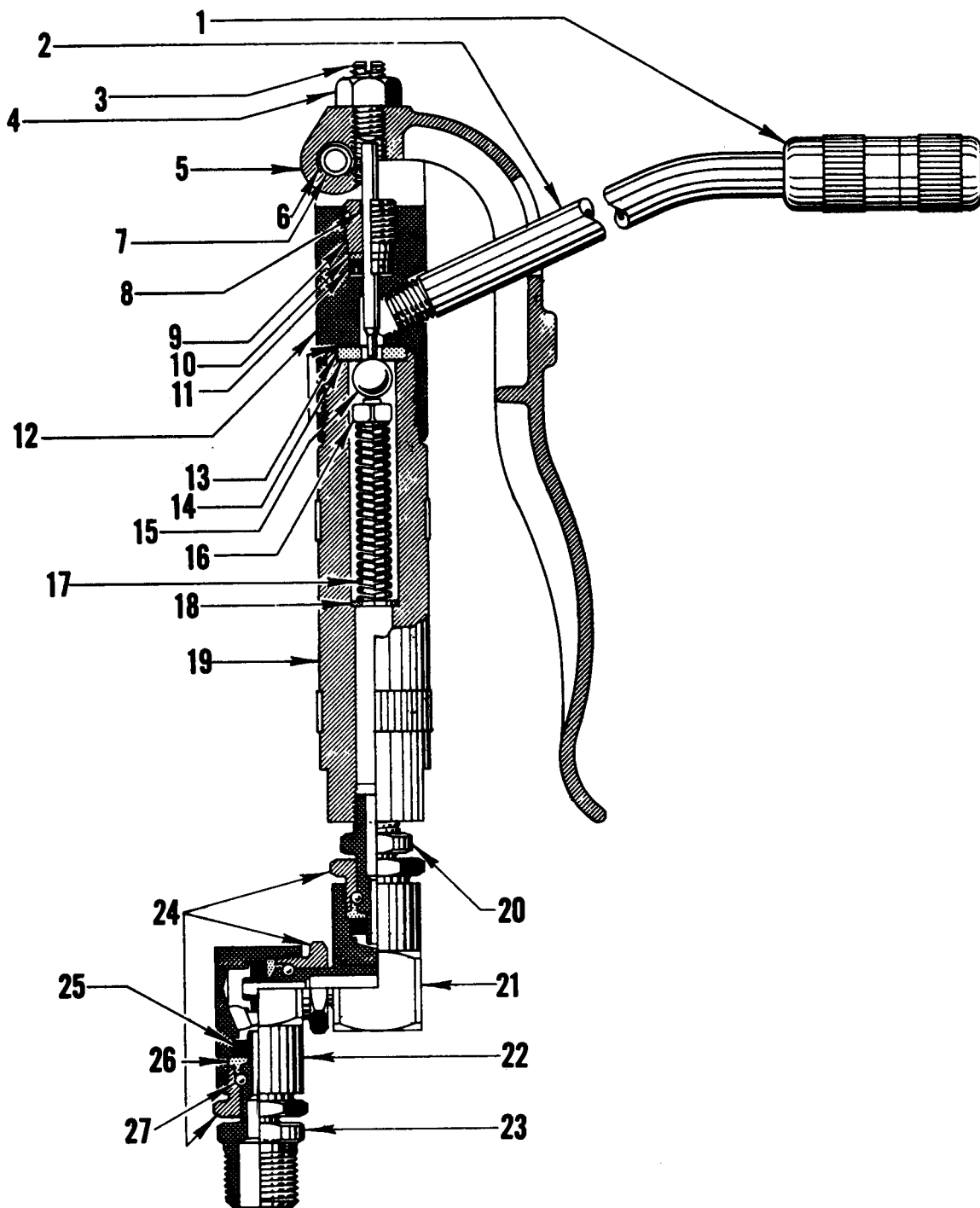

MEC 4930-217-14/3-28

Figure 3-28. —Continued.



1 Adapter	7 Meter	13 Pin	19 Retainer ring
2 Nipple	8 Meter	14 Body	20 Washer
3 Tip	9 Adapter	15 Adapter	21 Spring
4 Adapter	10 Bushing	16 Hand grip	22 Valve
5 Nozzle	11 Nipple	17 Screen	23 Valve stem
6 Bushing	12 Trigger	18 Retainer	24 O-ring

Figure 3-29. —Continued.

---

**Section XVIII. HOSE REEL ASSEMBLIES**  
**(Used only on Units with Serial Number 84-29943 thru 84-30304**  
**and 86-30305 thru 86-31248)**

**3-104. General**

The hose reel bank consists of five reels and hoses mounted on a common base. Four of the hoses are used to dispense chassis, gear and engine oil. One hose is used for dispensing air under pressure. Each hose reel is equipped with a lock to prevent hoses from unreeling.

**3-105. Chassis, Gear and Engine Oil Reels**

Removal and installation of the reels can be performed as described in paragraph 3-101.

**3-106. Metering Valves (Quart and Pint)**

*a. General.* The metering valves are designed for dispensing gear and motor oil. The gear oil metering valve indicates amount dispensed in pints and the motor oil metering valve in quarts.

*b. Removal.* These two metering valves are removed in the same manner as the two controls described in paragraph 8-103.

*c. Disassembly.*

(1) Remove face dial (2, fig. 3-30) by removing the four screws (1) holding it.

(2) Lift the totalizer (4) out.

(3) Loosen adjustment screw (5) on worm gear (7) and lift worm gear out!

(4) Remove fitting body (33), O-rings (34 and 35), metering mechanism (36), planetary gear (37), and gear and shaft assembly (38).

(5) Remove flat packing (40) and leather washer (41).

(6) Remove swivel adapter (22), split ring (23), and gasket (24).

(7) Remove swivel stem (19) and the V-packing block (21).

(8) Remove cotter pin (56) and pin (55) holding lever assembly (42). Remove lever assembly (42), spring (43), cap and pin assembly (44), plus (45), and two O-rings (46 and 47).

(9) Remove valve seat (48), O-ring (49), valve assembly (53) and spring (54).

(10) Remove extension (8 and 25) and disassemble nozzle assemblies of each metering valve.

*Note.* The nozzle assembly (26) of the quart control and nozzle assembly (9) of the pint control differ as shown in figure 3-30.

*d. Cleaning, Inspection and Repair.*

(1) Clean all parts in an approved cleaning solvent.

(2) Inspect all parts for wear or leakage. Replace defective parts.

(3) If lubricant leaks around the fitting body (33), replace O-rings (34 and 35).

(4) If lubricant leaks around the face dial (2), replace flat packing (40) and leather washer (41).

(5) If lubricant leaks around the lubricant inlet, replace V-packing block (21) and gasket (24).

(6) If lubricant leaks around the lever assembly (42), replace O-rings (46 and 47).

(7) Clean the valve assembly with a lint-free cloth.

*e. Reassembly.* Reassembly of the metering valves is the reverse of disassembly. Refer to figure 3-30 for aid in reassembly.

*f. Installation.* Installation is the reverse of removal.



1 Screw	16 Angle body	31 O-ring	44 Cap & pin assy
2 Face dial	17 O-ring	32 Cap	45 Plug
3 Spacer	18 Nozzle	33 Fitting body	46 O-ring
4 Totalizer	19 Swivel stem	34 O-ring	47 O-ring
5 Adjustment screw	20 Washer	35 O-ring	48 Valve seat
6 Retaining washer	21 Block V-packing	36 Metering	49 O-ring
7 Worm gear	22 Swivel adapter	37 Mechanism assy	50 Screw
8 Extension	23 Split ring	37 Planetary gear	51 Seat
9 Nozzle assy	24 Gasket	38 Gear and shaft assy	52 Plunger
10 Adapter & screw assy	25 Extension	39 Washer	53 Valve assy
11 Gasket	26 Nozzle assy	40 Flat packing	54 Spring
12 Washer	27 Body	41 Leather washer	55 Pin
13 Spring	28 O-ring	42 Lever assy	56 Cotter pin
14 Check stem	29 Spring	43 Spring	57 Housing
15 Block V-packing	30 Plunger		

Figure 3-30.—Continued.

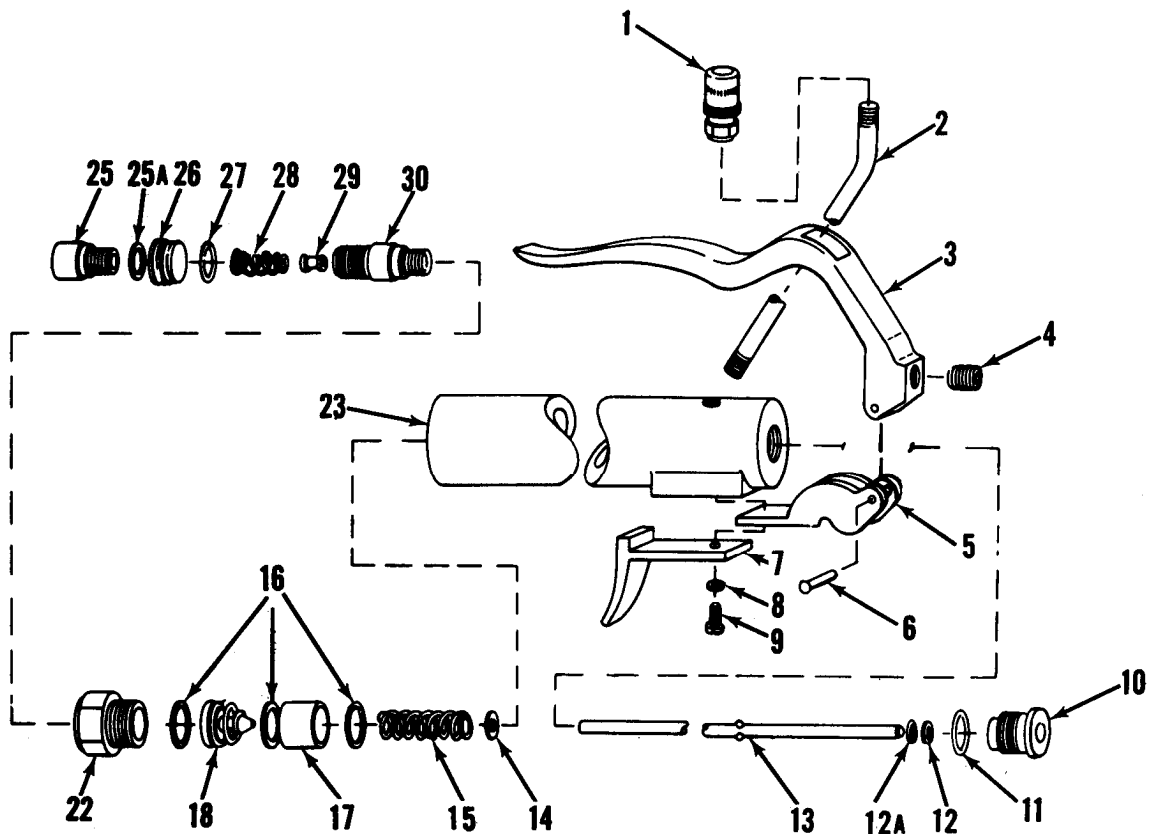

MEC 4930-217-14/3-31

1 Hydraulic coupler	9 Screw	16 Gasket (3)	24 Deleted
2 Extension	10 Packing plug	17 Spacer	25 Connector
3 Lever	11 Preformed packing	18 Spring-plunger-seat assy	25A Gasket
4 Set screw	12 Backup washer	19 Deleted	26 Lock nut
5 Bracket	12A Preformed packing	20 Deleted	27 Packing ring
6 Rivet	13 Plunger stem	21 Deleted	28 Spring
7 Support	14 Washer	22 Bushing	29 Valve seat
8 Washer	15 Spring	23 Body	30 Valve bushing

Figure 3-31. Grease control valve (used only on serial Nos. 84-29943 thru 84-30304 and 86-30305 thru 86-31248).



### 3-107. Control Valve (fig. 3-30)

*a. General.* The two control valves are of the squeeze lever type and are used to control the amount of grease being dispensed.

*b. Removal.* Remove the two grease control valves in a similar manner as the two high pressure control valves described in paragraph 3-102.

*c. Disassembly.* Disassemble the control valve as shown in figure 3-31.

#### *d. Cleaning, Inspection and Repair.*

(1) Clean all parts in an approved cleaning solvent.

(2) Replace all packing in the control valve.

(3) Inspect parts for damage or defects. Replace parts if necessary.

(4) Compress spring plunger and seat assembly (18, fig. 3-31) to clean and inspect. If seat is scored, replace.

(5) Clean the strainer on the hydraulic coupler (1).

(6) Replace all worn parts with new parts.

*e. Reassembly.* Reassembly of control valve is the reverse of disassembly. Refer to figure 3-31 as an aid to reassembly.

#### *f. Adjustments.*

##### (1) *Single shot delivery.*

(a) Loosen locknut (26).

(b) Turn adjusting screw clockwise until a definite stop is felt, then turn counterclockwise approximately one and a quarter turns.

*Note.* Do not force the adjustment screw.

(c) Tighten locknut (26).

##### (2) *Amount of single shot delivery.*

(a) Leave pressure on nose and loosen locknut (26).

(b) Turn adjusting screw clockwise (tightening) to decrease the amount of lubricant delivered; turn counterclockwise (loosening), to increase the amount.

*Note* Turn the adjustment screw about an eighth of a turn at a time.

(c) While adjusting open the control valve several times to determine whether or not the adjustment is satisfactory.

(d) Tighten locknut.

(3) *Lever adjustment.* The lever (3) of the control valve should be adjusted so there is a  $\frac{1}{8}$  inch clearance between the bottom of the hole in the lever and the extension (2) without a lubricant delivery. Adjust hex socket setscrew (4) until the handle has the  $\frac{1}{8}$  inch clearance.

*g. Installation.* Installation is the reverse of removal. Refer to paragraph 3-102.

## Section XIX. LUBRICATING EQUIPMENT

### 3-108. General

This section contains information on the oil suction gun, the air operated oil spray gun, the grease gun, the pneumatic gun, the portable lubricator assembly, pumps, regulators, and gages.

### 3-109. Oil Suction Gun

No removal or installation is necessary for this piece of equipment as it is a hand operated oil suction device. Simply lift it from its storage position in the lower drawer (fig. 2-5). After completed operation, return to storage position.

### 3-110. Grease Gun

No removal or installation is necessary for the

grease gun as it is merely stored in the lower drawer assembly.

### 3-111. Portable Lubricator

*a. Removal.* Remove the portable lubricator (61, fig. 3-8) from its storage bracket (62), and the lubricator is ready to use (para 2-27).

*b. Installation.* Return the portable lubricator to its storage bracket.

### 3-112. Air Operated Oil Spray Gun

*a. Removal.* The oil spray gun is stored in the upper drawer assembly (fig. 2-6) and has no removal operation. However, during operation the oil spray gun is threaded to the air hose (8, fig. 3-8) in place of the pneumatic gun (16, fig. 3-8). Remove the oil spray gun

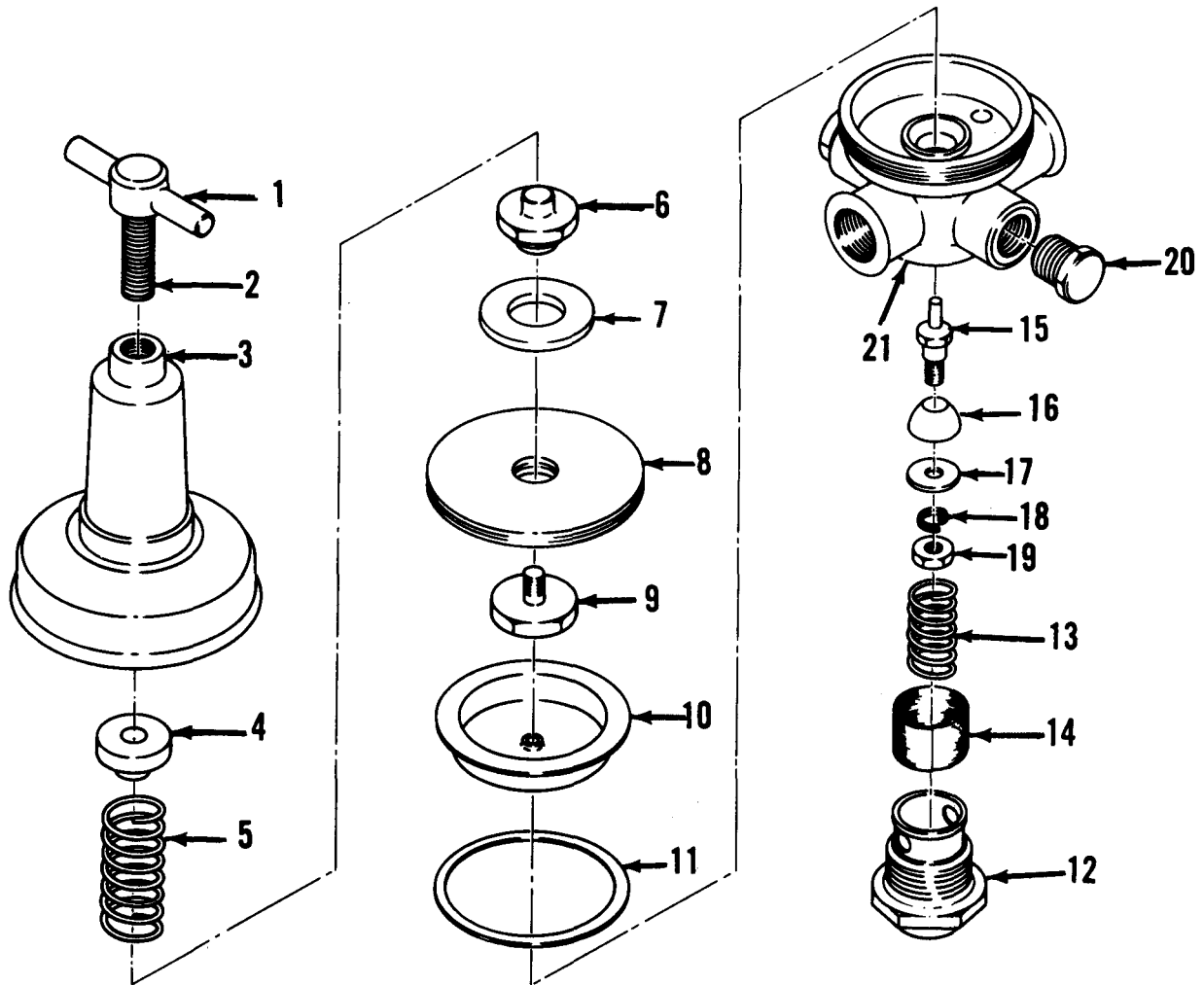

ME 4930-217-14/3-32

- |          |             |           |           |
|----------|-------------|-----------|-----------|
| 1 Handle | 7 Plate     | 12 Plug   | 17 Washer |
| 2 Screw  | 8 Diaphragm | 13 Spring | 18 Washer |
| 3 Bonnet | 9 Clamp     | 14 Screen | 19 Nut    |
| 4 Button | 10 Plate    | 15 Stem   | 20 Plug   |
| 5 Spring | 11 Gasket   | 16 Valve  | 21 Body   |

Figure 3-32. Air regulator assembly (Serial Numbers 69-29787 through 69-99942).

from the hose (8) by holding the coupling (10) with a wrench and turn the oil spray gun in a counterclockwise direction until it releases from the hose.

*b. Installation.* Install the oil spray gun in reverse of removal.

### 3-113. Pneumatic Gun

*a. Removal.* Remove the gun (16, fig. 8-8) from the air hose (8) by holding the coupling

(10) with a wrench and turn the gun in a counterclockwise direction until it releases from the hose (8).

*b. Installation.* Install the gun in reverse of removal.

### 3-114. Lubrication Pumps

*a. Removal.*

(1) Disconnect necessary hose connections.

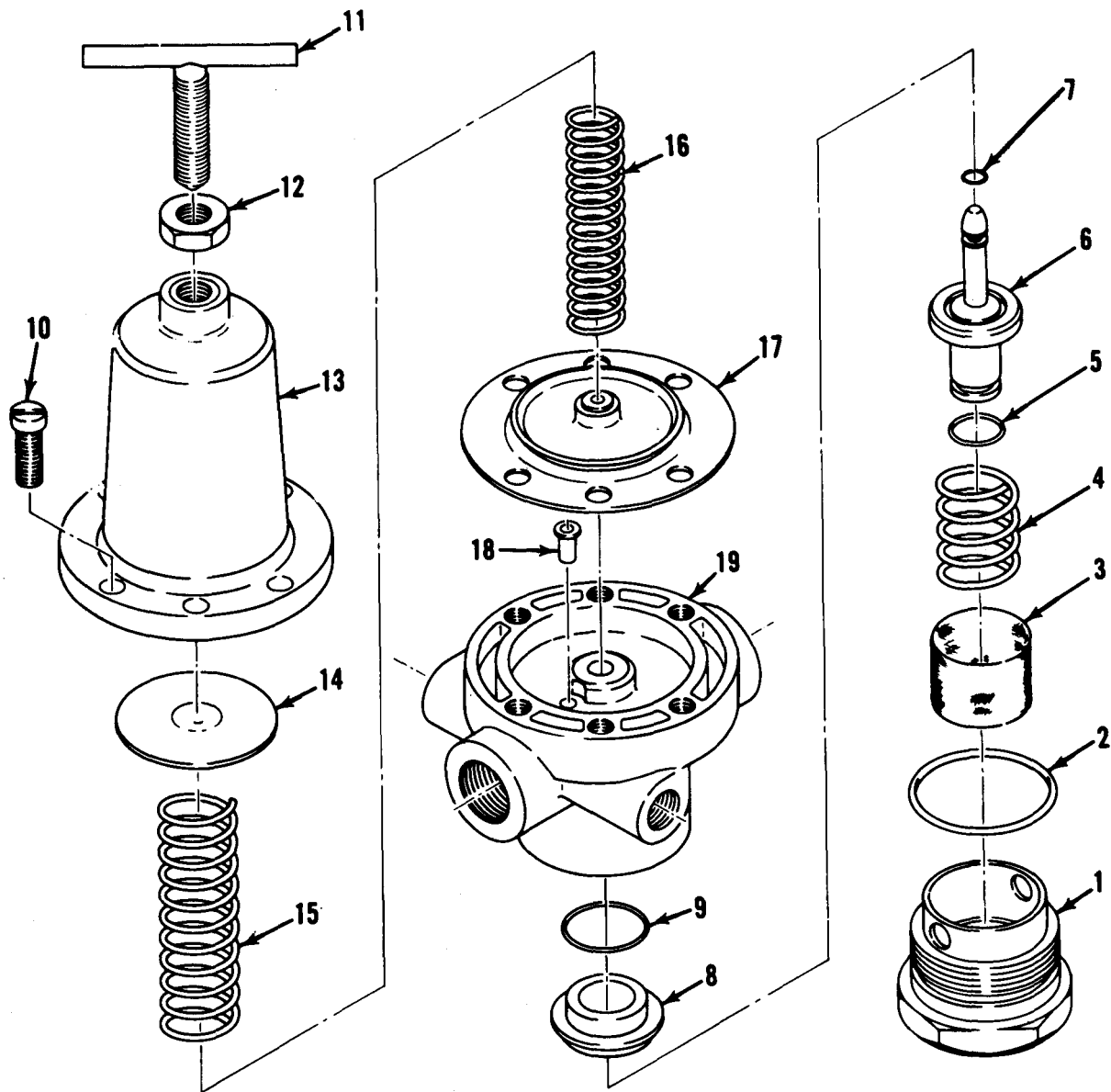

ME 4930-217-14/3-33

- |                  |              |                |                   |
|------------------|--------------|----------------|-------------------|
| 1 Screw assembly | 6 Valve assy | 11 Handle      | 16 Plate          |
| 2 O-ring         | 7 O-ring     | 12 Jam nut     | 17 Diaphragm assy |
| 3 Screen         | 8 Seat       | 13 Bonnet assy | 18 Eyelet         |
| 4 Spring         | 9 O-ring     | 14 Spring pad  | 19 Body           |
| 5 O-ring         | 10 Screw     | 15 Spring      |                   |

Figure 3-33. Air regulator assembly (Serial Nos. 84-29943 thru 84-30304 and 86-30305 thru 86-31248).

(2) Remove the four attaching screws and remove the low pressure pump (45, fig. 3-3).

(3) Remove gasket (46).

*b. Installation.* Install the high pressure pump in reverse of removal, The high pressure pump (44) is removed and installed in a similar manner.

### 3-115. Air Pressure Regulator, Fittings and Gage

#### *a. Removal.*

(1) Remove elbow (51, fig. 3-3) from pumps (44 and 45); remove fitting (52) and nipple (51) from air regulator (49).

(2) Remove gage (54) from air regulator (49) by turning the gauge counterclockwise.

*b. Disassembly.* Disassemble the regulator in the numerical sequence shown in figure 3-32 for regulators used on serial numbers 69-29737 through 69-29942 and figure 3-33 for regulators used on serial numbers 84-29943 through 84-30304 and 86-30305 through 86-31248.

*c. Cleaning, Inspection and Repair.*

(1) Replace all worn or damaged parts.

(2) Clean all parts in an approved cleaning solvent.

(3) Replace all O-rings.

*d. Reassembly.* Reassemble the regulator in the reverse of numerical sequence as shown in figure 3-32 for those used on Serial Numbers 69-29737 through 69-29942 and figure 3-33 for those used on Serial Numbers 84-29943 through 84-30304 and 86-30305 through 86-31248.

*e. Installation.* Installation is the reverse of removal.

### Section XX. AIR PRESSURE GAUGE, COMPRESSOR RELIEF VALVE, AND AIR RECEIVER TANK

#### 3-116. General

The air pressure gauge indicates the pressure contained in the air receiver tank. The

compressor relief valve is a pressure regulated device which transmits receiver pressure to the suction valve unloaders when the pressure

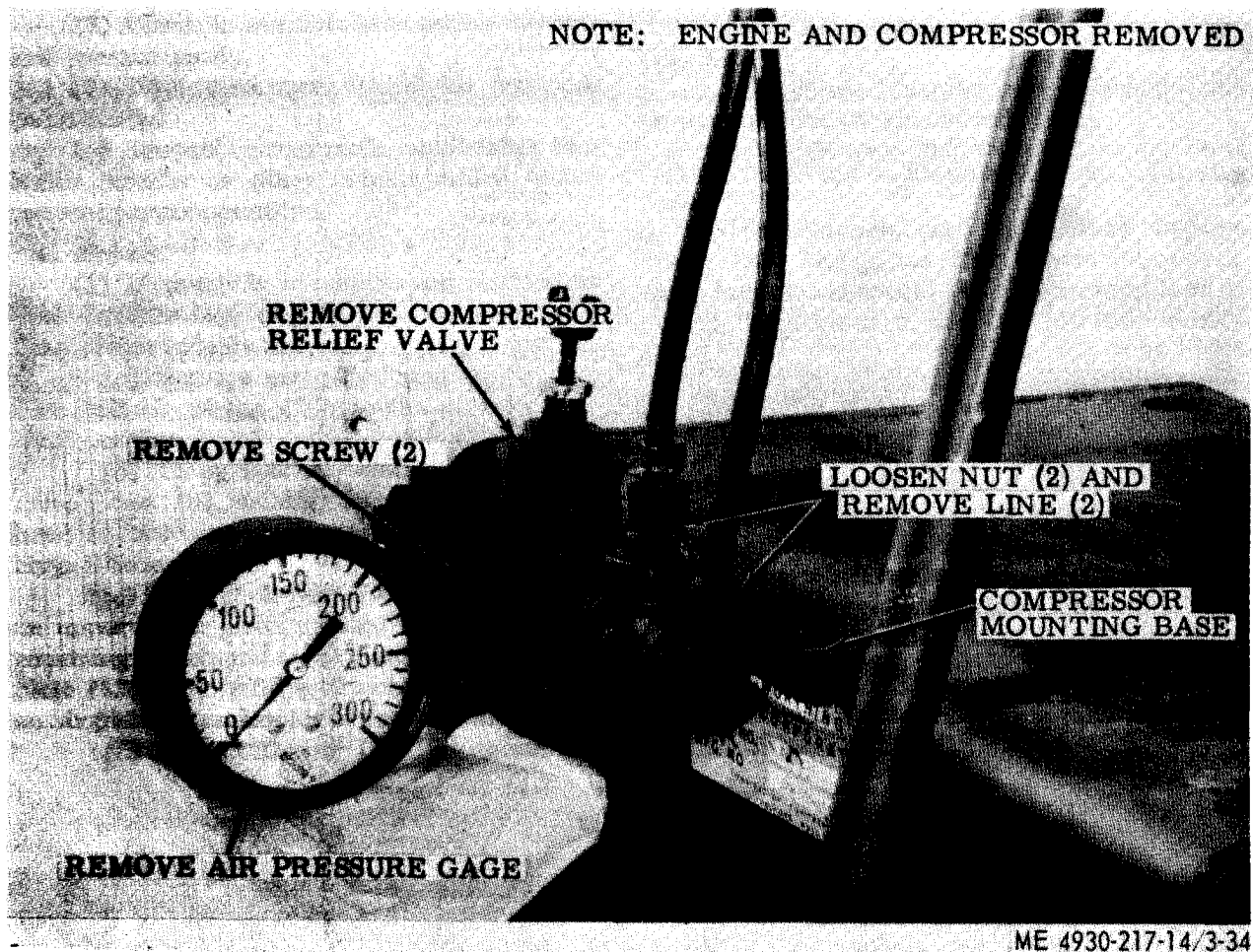

Figure 3-34. Air pressure gauge and compressor relief valve, lines and fitting —removal and installation.

reaches the high limit, thereby unloading the compressor. When the receiver pressure drops to the load limit, the valve releases pressure from the suction valve unloaders, thereby allowing the suction valves to function normally.

### 3-117. Air Pressure Gage and Compressor Relief Valve, lines and Fittings

*a. Removal.* Refer to figure 6-84 and remove

the air pressure gauge, relief valve, lines and fittings.

*b. Installation.* Installation is the reverse of removal.

### 3-118. Air Receiver Tank

Open air drain valve (66, fig. 3-8) to relieve pressure and moisture from air receiver tank.

## Section XXI. ALCOHOL DISPENSER, MASTER AIR VALVE, LINES AND FITTINGS

### 3-119. General

This section covers removal and installation instructions for the alcohol dispenser, lines and fittings including the master air valve.

### 3-120. Alcohol, Dispenser, Master Air Valve, lines and Fittings

*a. Removal.* Remove the alcohol dispenser, its lines and fittings, and the master air valve as shown in numbered sequence in figure 3-35.

*b. Installation.* Installation is the reverse of removal.

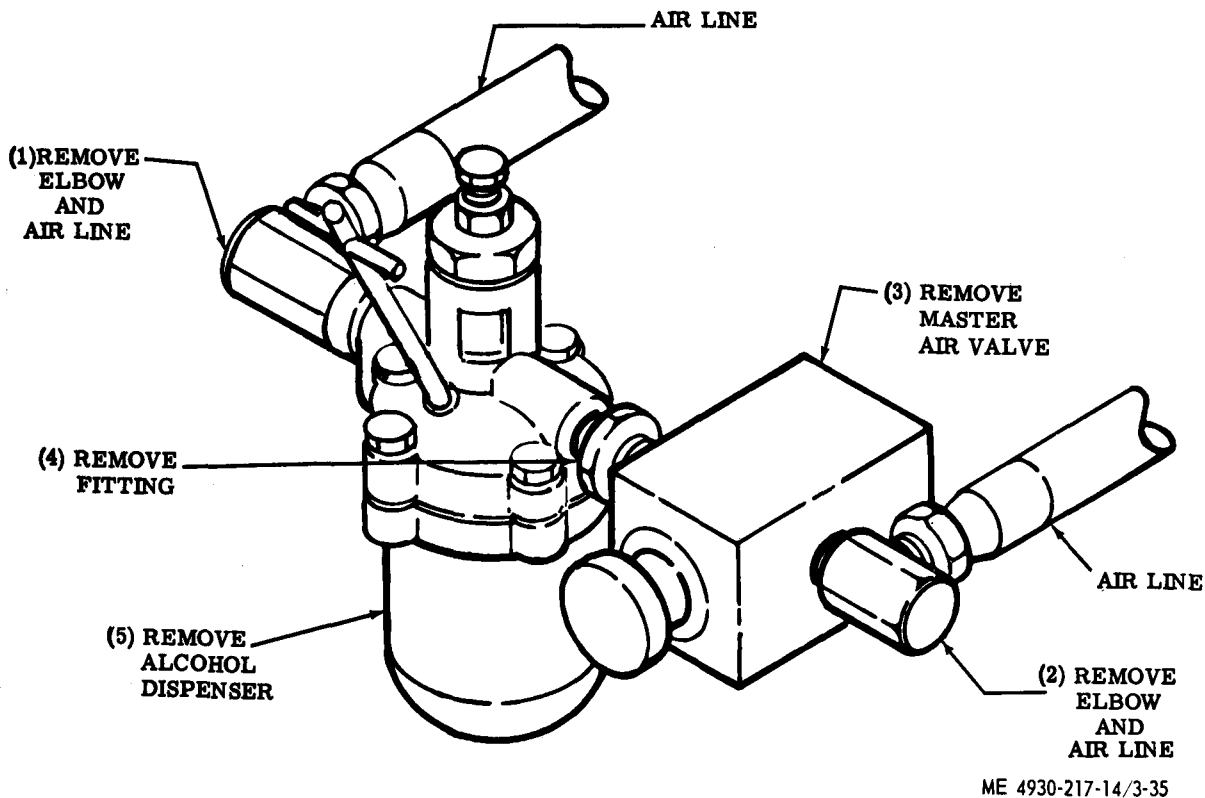

Figure 3-35. Alcohol dispenser, master air valve, lines and fittings removal and installation.

CHAPTER 4  
DIRECT AND GENERAL SUPPORT MAINTENANCE  
INSTRUCTIONS

**Section I. GENERAL**

**4-1. Scope**

These instructions are published for the use of direct and general support maintenance personnel maintaining the lubricating and servicing unit. They provide information on the maintenance of the equipment, which is beyond the scope of tools, equipment, personnel, or supplies normally available to using organizations.

**4-2. Record and Report Forms**

For record and report forms applicable to direct and general support and depot maintenance, refer to TM 38-750.

*Note.* Applicable forms, excluding Standard Form 46, which is carried by the operator, shall be kept in a canvas bag mounted on the equipment.

**Section II. DESCRIPTION AND TABULATED DATA**

**4-3. Description**

For a complete description of the lubricating and servicing unit, see paragraph 1-3.

**4-4. Tabulated Data**

*a. General.* This paragraph contains all the overhaul data pertinent to direct and general support maintenance personnel.

*b. Lubricator Data.* For complete tabulated

data on the lubricating and servicing unit refer to paragraph 1-4.

*c. Engine Data.* Refer to TM 5-2805-203-14 for tabulated data related to the engine.

*d. Repair and Replacement Standards.* Table 4-1 lists the manufacturer's sizes, tolerances, desired clearance and maximum allowable wear and clearances for the components of the compressor.

*Table 4-1. REPAIR AND REPLACEMENT STANDARDS*

Component	Manufacturer's dimensions and tolerances in inches		Desired clearance		Maximum allowable wear and Clearance
	Minimum	Maximum	Minimum	Maximum	
COMPRESSOR :					
Crankshaft:					
End play	0.0005	0.002	-----	-----	0.0015
Connecting Rods:					
Wrist pin	-----	-----	0.0001	0.0005	0.0004
Crank pin	-----	-----	0.0008	0.0016	0.0008
Piston, H.P.					
Ring gap	0.003	-----	-----	-----	-----
Side clearance	0.0005	-----	0.0005	-----	-----
Piston, L.P.					
Ring gap	0.003	-----	-----	-----	-----
Side clearance	0.0015	-----	0.0015	-----	-----

## CHAPTER 5

### GENERAL MAINTENANCE INSTRUCTIONS

---

#### Section I. SPECIAL TOOLS AND EQUIPMENT

##### 5-1. Special Tools and Equipment

No special tools and equipment are required by direct and general support maintenance personnel for performing maintenance on the lubricating and servicing unit.

##### 5-2. Specially Designed Tools and Equipment

No specially designed tools and equipment are required by direct and general support maintenance personnel for performing maintenance on the lubricating and servicing unit.

#### Section II. TROUBLESHOOTING

##### 5-3 General

This section provides information useful in diagnosing and correcting unsatisfactory operation or failure of the lubricating and servicing unit or any of its components. Each trouble symptom stated is followed by a list of probable causes. The possible remedy recommended is described opposite the probable cause. Refer to TM 6-2805-203-14 concerning troubleshooting the engine.

##### 5-4. Compressor High or Low Pressure System Overheats

<i>Probable Cause</i>	<i>Possible Remedy</i>
Scored piston or cylinder wall -----	Replace piston or hone. (para 7-2).
Broken discharge valves or springs.	Replace valves (para 7-2).

##### 5-5. Compressor Knocks or Develops Excessive Noise

<i>Probable Cause</i>	<i>Possible Remedy</i>
Piston pins worn -----	Replace piston pins and pistons (para 7-2).
Connecting rods loose ---	Replace defective bearings (para 7-2). Tighten or replace defective connecting rods (para 7-2).

##### 5-6. Excessive Compressor Oil Consumption

<i>Probable Cause</i>	<i>Possible Remedy</i>
Incorrect oil _____	Change oil and add correct oil (LO 5-493&217-12).
Clogged air cleaner ____	Service air cleaner (para 3-98) .
Worn piston rings ____	Replace piston rings. Be sure rings are installed correctly (para 7-2).

##### 5-7. Transfer Pump Does not Operate

<i>Probable Cause</i>	<i>Possible Remedy</i>
Defective air valve and piston.	Repair or replace air valve or piston (para 3-7 for pumps used on serial numbers 69-29737 thru 69-29942) (para 3-9 for pumps used on serial numbers 84-29943 thru 84-30304 and 86-30305 thru 86-31248) .
Defective foot valve ____	Repair or replace foot valve. (para 3-7 for pumps used on serial numbers 69-29737 thru 69-29942) (para 3-9 for pumps used on serial numbers 84-29943 thru 84-30304 and 86-30305 thru 86-31248).

### 5-8. Lubricant Supply Pump Does Not Operate

<i>Probable Cause</i>	<i>Possible Remedy</i>
Defective control or metering valves.	Replace valves.
Defective pumps _____	Repair or replace pumps.

### 5-9. High Pressure Pump Hose Pulsates with Absence of Grease Under Pressure

<i>Probable Cause</i>	<i>Possible Remedy</i>
Primer valve or ball not seating properly -----	Clean ball seat and primer valve (para 8-2d).

### 5-10. Grease Leaking Where Tube Enters High Pressure Cylinder Support

<i>Probable Cause</i>	<i>Possible Remedy</i>
Packings damaged -----	Replace packings (para 8-2d).

### 5-11. High Pressure Pump Air Piston Not Tripping or Air Blowing Constantly From Air Piston

<i>Probable Cause</i>	<i>Possible Remedy</i>
O-ring or valve in air piston worn or damaged.	Replace (para 8-2d)

### 5-12. Low Pressure Pump Operates with Control Handle Shut Off

<i>Probable Cause</i>	<i>Possible Remedy</i>
Foreign matter in foot valve.	Clean valve (para 8-3d(1)).
Foreign matter in transfer valve.	Clean valve (para 8-3d(1)).

### 5-13. Oil Leaking Where Tube Enters Low Pressure Pump Adapter

<i>Probable Cause</i>	<i>Possible Remedy</i>
Defective seal _____	Replace seals (para 8-3d(2)).

### 5-14. Low Pressure Pump Air Piston Not Tripping or Air Blowing Constantly From Air Piston

<i>Probable Cause</i>	<i>Possible Remedy</i>
Defective O-rings or valve in air piston.	Replace O-ring or valve (para 8-3d(3)).

### 5-15. High Pressure Hose Reel Leaks at Swivel

<i>Probable Cause</i>	<i>Possible Remedy</i>
Defective packing _____	Replace packing (sect. V and VI, ch 8).

### 5-16. Low Pressure Hose Reel Leaks at Swivel

<i>Probable Cause</i>	<i>Possible Remedy</i>
Defective swivel -----	Replace swivel (para 8-11 and 3-13).

### 5-17. Grease Leaks from Chassis Control Handle Chuck

<i>Probable Cause</i>	<i>Possible Remedy</i>
Trigger not properly adjusted.	Adjust trigger (para 3-102).
Defective ball seat insert or ball.	Replace insert or ball (para 3-102).

### 5-18. Grease Leaks from High Pressure Chassis Control Valve Stem

<i>Probable Cause</i>	<i>Possible Remedy</i>
Packing worn or damaged.	Replace packing (para 3-102).

### 5-19. Oil Leaks from Low Pressure Control When Valve is Off

<i>Probable Cause</i>	<i>Possible Remedy</i>
Defective valve _____	Replace valve (para 3-103).
Trigger not adjusted _____	Adjust trigger (para 3-103d).
Defective O-rings _____	Replace O-rings (para 3-103).

## Section III. REMOVAL AND INSTALLATION OF MAJOR COMPONENTS AND AUXILIARIES

### 5-20. General

This section contains the removal and installation instructions for the service brakes backplate, trailer frame, and the air tank receiver.

### 5-21. Service Brakes Back Plate

#### a. Removal.

(1) Remove the brake shoes and wheel cylinders (para 3-76).

(2) Refer to figure 5-1 and remove the back plate.

#### b. Cleaning and Inspection.

(1) Clean the backplate with an approved cleaning solvent and dry thoroughly.

(2) Inspect for cracks, breaks, and other damage.

(3) Replace a damaged or defective backplate.



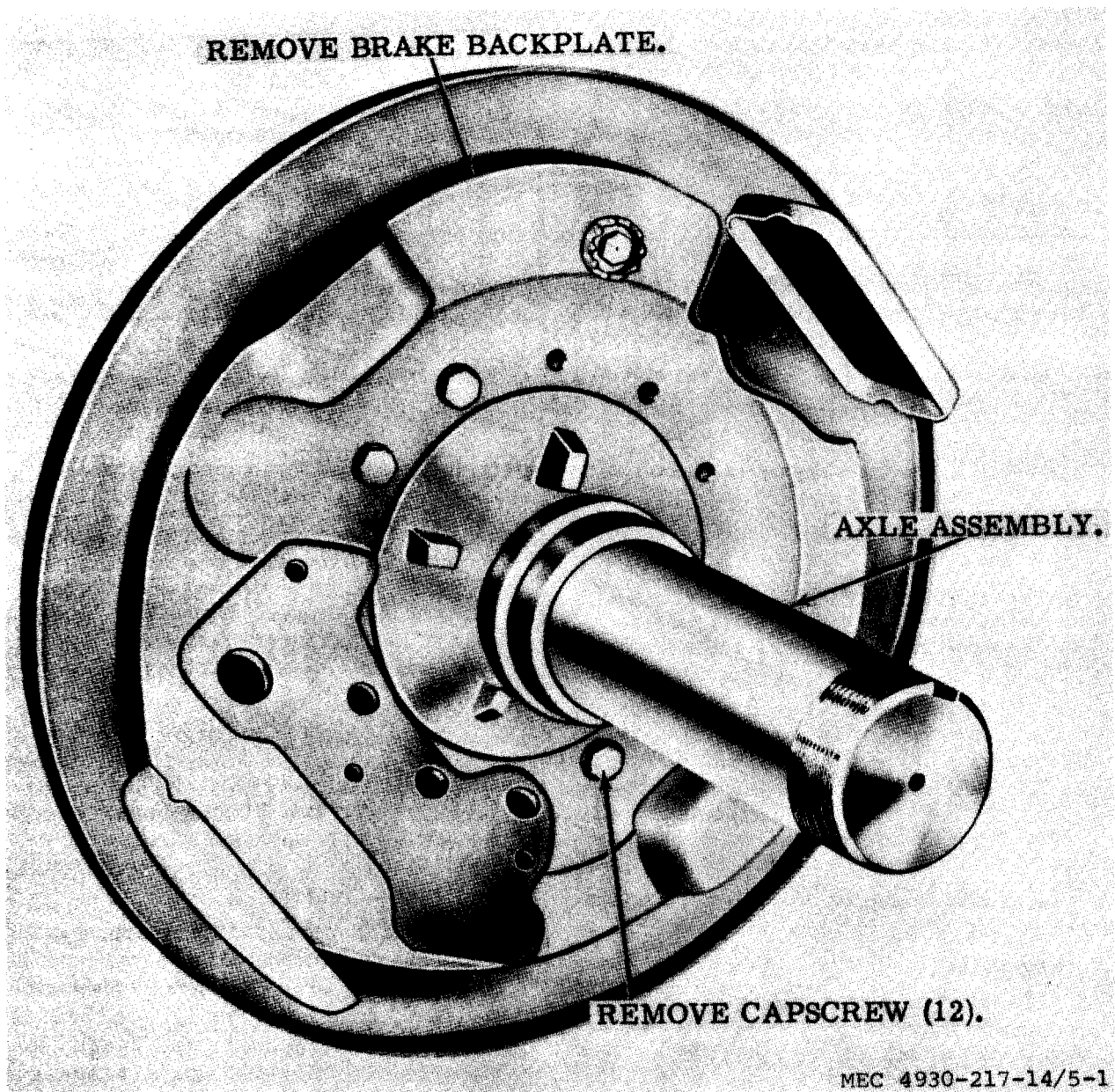

Figure 5-1. Service brake back plate-removal and installation.

*c. Installation.*

(1) Refer to figure 5-1 and install the backplate.

(2) Install the brakeshoes and wheel cylinders (para 3-76).

**5-22. Axle Assembly**

*a. General.* The trailer axle is a welded assembly consisting of an axle tube and a tie

beam connecting the axle tube with a stub axle on which the wheels are mounted. The axle tube is mounted to the trailer frame with two bearings, one on each side of the trailer frame. A shock absorber mounting link is welded to each end of the axle tube.

*b. Removal.*

(1) Remove the shock absorbers (para 3-84).

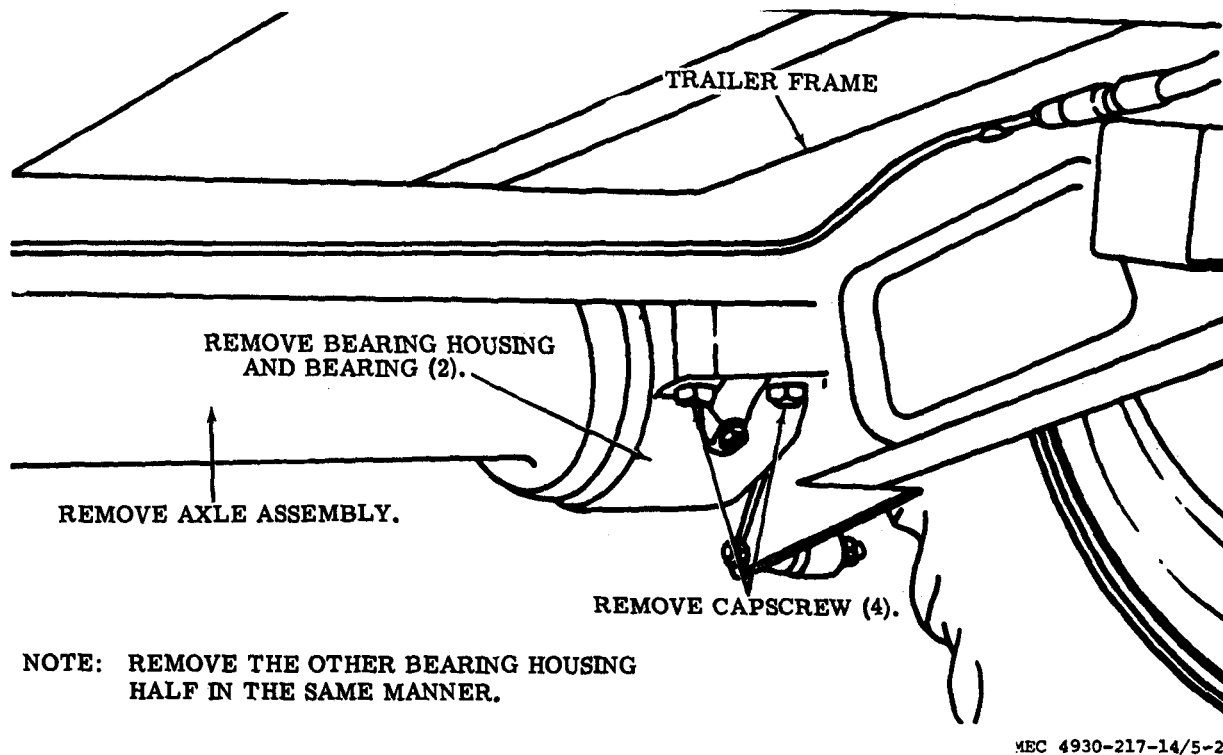

*Figure 5-2. Axle assembly—removal and installation.*

- (2) Remove the spring (para 3-85).
- (3) Remove the brake assemblies (para 3-76).
- (4) Refer to figure 5-2 and remove the axle assembly.

**c. Installation.**

- (1) Refer to figure 5-2 and install the axle assembly.
- (2) Install the brake assemblies (para 3-76).
- (3) Install the springs (para 3-85).
- (4) Install the shock absorbers (para 3-84).

**5-23. Air Tank Receiver**

**a. Removal.**

- (1) Drain off air pressure that may exist in the air tank receiver.
- (2) Disconnect all lines connected to the air tank receiver.
- (3) Refer to figure 5-3 and remove the air tank receiver.

- b. Installation.** Installation is the reverse of removal.

**5-24. Trailer Frame**

**a. General.** The trailer frame is an all-steel-welded construction consisting of two parallel frame rails with cross-members between the rails. The frame has a landing gear bracket spring hanger bracket, hand lifting bars, lashing rings and two upper halves of the bearing housing welded to it.

**b. Removal and Disassembly.**

- (1) Remove the enclosure assembly (para 3-37).
- (2) Remove the battery drawer (para 3-38).
- (3) Remove the toolbox, trouble light reel and fuel filler assembly (para 3-39).
- (4) Remove the engine assembly (para 3-41).
- (5) Remove the trailer blackout stop and taillight (para 3-64).

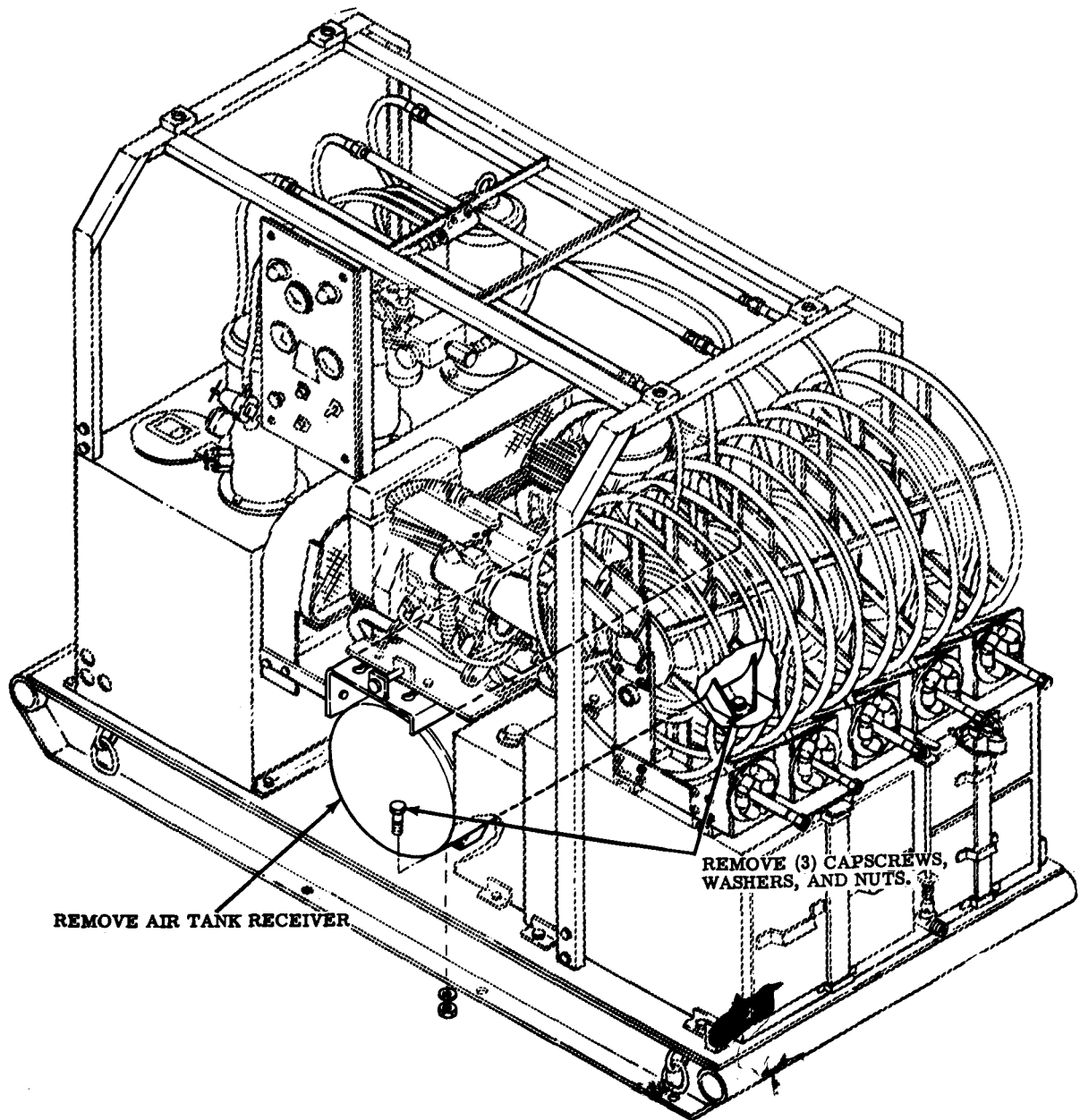

MEC 4930-217-14/5-3

*Figure 5-3. Air tank receiver-removal and installation.*

(6) Remove stoplight, directional taillight and the reflectors (para 3-65).

(7) Remove trailer clearance lights (para 8-66) .

(8) Remove wiring harness and electrical receptacle (para 3-70).

(9) Remove compressor drive belt guard

(para 3-93), the belts (para 3-94), and the compressor (para 3-97).

(10) Remove the hose reel assemblies (para 3-101).

(11) Remove the lubrication pumps (para 3-114).

(12) Remove the air tank receiver (para 5-23).

(13) Remove wheels (para 3-72).

(14) Remove brakes (para 3-76), and master cylinder para (3-77), brake air chamber (para 3-78) and air relay valve (para 3-79).

(15) Remove air reservoir (para 3-80) and air filters (para 3-81).

(16) Remove the backing plates (para 5-21) .

(17) Remove landing gear (para 3-83), shock absorbers (para 3-84), hangers and springs (para 3-85).

(18) Remove springs and bumpers (para

3-86), lunette (para 3-87) and wheel chocks (para 3-88).

(19) Remove fenders (para 3-89).

(20) Remove safety chains (para 3-90) and intervehicular hoses (para 3-91) .

(21) Remove the base skid by removing the four each bolts, washers and nuts that attach the skid to the trailer frame.

(22) Remove the axle (para 5-22).

(23) Replace trailer frame.

*c. Installation.* Install the trailer frame in reverse of removal.

## CHAPTER 6

### ELECTRICAL COMPONENTS REPAIR INSTRUCTIONS

---

#### Section I. GENERATOR ASSEMBLY

##### 6-1. General

The generator assembly has an armature mounted on bearings at both ends. The armature rotates between pole shoes over which are wound field coils. The voltage and current developed in the armature windings is supplied through brushes riding on a commutator to the generator terminals and then to the batteries and other electrical accessories in the circuit.

##### 6-2. Generator and Components

###### *a. Removal and Disassembly.*

(1) *Removal.* Remove the generator as described in paragraph 3-55.

(2) *Disassembly.* Disassemble as shown in figure 6-1.

###### *b. Cleaning, Inspection, Repair and Testing.*

###### (1) Cleaning.

(a) Use a cloth dampened with an approved solvent to wipe all dust, oil, and other foreign material from the brush plates, end frames, armature and field assemblies.

(b) Use filtered compressed air to blow dust and dirt from the crevices of the armature and field windings.

(c) Secure armature in a lathe. With armature spinning, hold a sheet of No. 000 sandpaper against the commutator until the copper is bright and smooth.

###### (2) Inspection.

(a) Examine field coils for worn, burned insulation. Be certain connections between field coils are secure, Repair connections if necessary.

(b) Examine field frame assembly for cracks and distortions. Check thread conditions in tapped holes,

(c) Check drive end head for cracks or warping. Inspect shaft end of armature for damage and wear.

(d) Examine pulley for broken flanges and worn shaft hole. Inspect brushes for wear or damage.

###### (3) Repair.

(a) Check commutator with a dial indicator for out-of-round. If total out-of-round exceeds 0.001 inch, turn down commutator on lathe.

(b) Replace armature or coils if tests indicate shorts.

(c) Replace all parts indicating cracks, wear, or damage.

(d) Replace brush springs that are worn or fatigued. Replace brushes.

(e) Undercut mica insulation between the commutator bars to a depth of  $\frac{1}{32}$  of an inch. When undercutting mica, the cut should be square and free of burrs.

###### (4) Testing.

(a) Use a conventional test light and check field coils for open circuits and shorts to ground or between coils.

(b) Check armature assembly for open coils and shorts to ground, or between coils by using a test light.

(c) Check brushholders for shorts to ground with a test light.

###### *c. Armature End Play Test.*

(1) Aline end of armature shaft with plunger of dial indicator. Pull shaft to outer limit and set dial indicator.

(2) Push shaft in toward commutator end of generator to its inner limit. Dial indicator should read between 0.003 and 0.010 inch.

(3) If dial indicator reading is not within



## Section II. STARTER ASSEMBLY

### 6-3. General

The shift lever cranking motor has the shift lever mechanism and the solenoid plunger enclosed in the drive housing protecting them from exposure to dirt and icing conditions. A solenoid switch mounted to the flange on the starting motor drive housing operates the over running clutch drive by means of a linkage and

shift lever. When the control switch closes the cranking circuit the solenoid is energized, shifting the starting motor pinion into mesh with the engine flywheel ring gear and closing the main contacts located inside the solenoid. Battery current is then directed to the motor causing the armature to rotate. Cranking torque is transmitted by the clutch from the

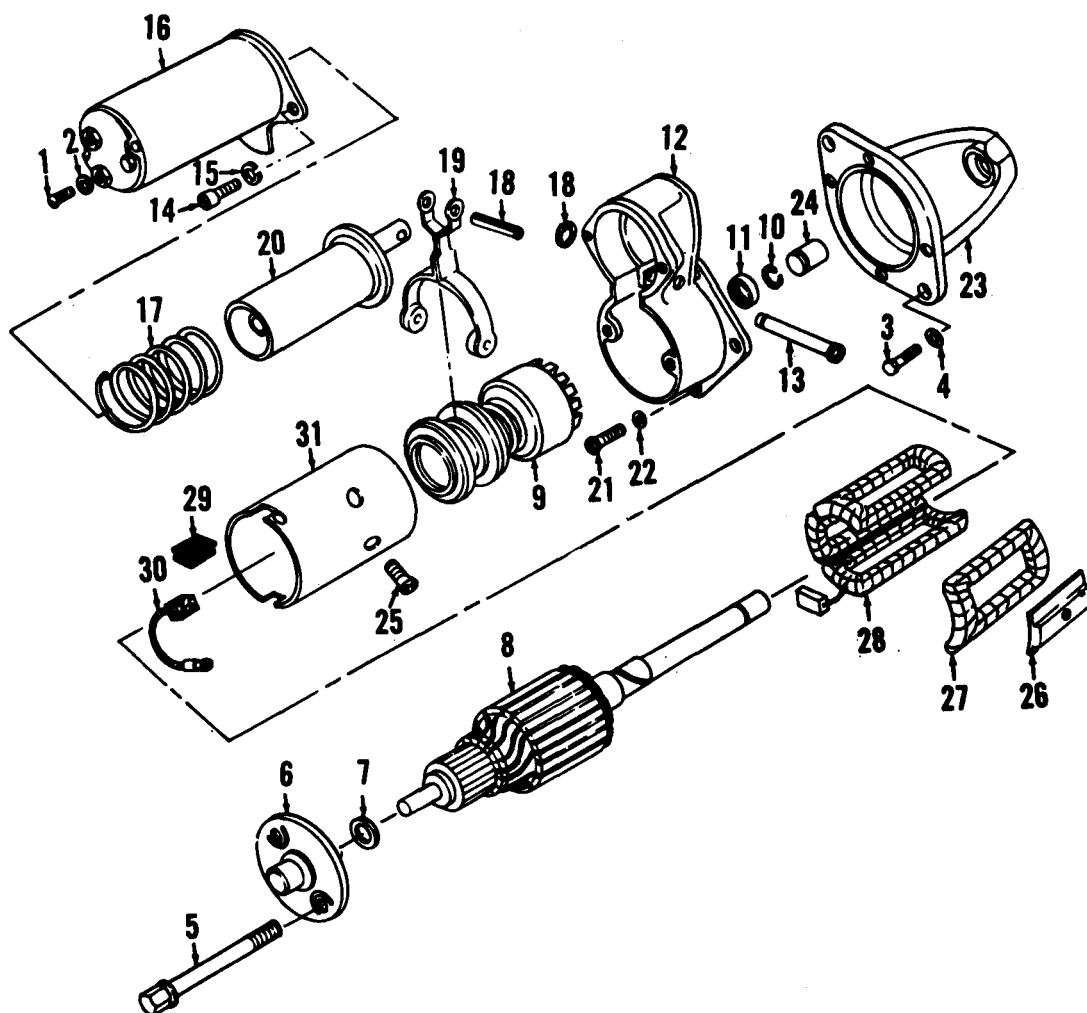

MEC 4930-217-14/6-2

- |                 |                    |                      |                        |
|-----------------|--------------------|----------------------|------------------------|
| 1 Screw         | 9 Clutch           | 17 Spring            | 25 Screw               |
| 2 Washer        | 10 Ring            | 18 Pin-ring assembly | 26 Pole shoe           |
| 3 Bolt          | 11 Pinion stop     | 19 Lever assembly    | 27 Shunt               |
| 4 Washer        | 12 Housing         | 20 Plunger assembly  | 28 Field coil assembly |
| 5 Bolt          | 13 Stud            | 21 Screw             | 29 Grommet             |
| 6 Frame         | 14 Screw           | 22 Washer            | 30 Brush set           |
| 7 Washer        | 15 Lockwasher      | 23 Housing           | 31 Housing             |
| 8 Armature assy | 16 Solenoid switch | 24 Bushing           |                        |

Figure 6-2. Starter assembly.

starting motor armature to the engine flywheel ring gear.

#### 6-4. Starter

##### a. Removal and Disassembly.

(1) *Removal.* Refer to paragraph 3-57 and remove the starter.

##### (2) *Disassembly.*

(a) Remove screw (14, fig. 6-2) and lockwashers (15), attaching solenoid switch (16) to housing (12). Remove solenoid and spring (17).

(b) Unscrew and remove two bolts (3), screws (21), and washers (22). Remove drive housing (23), bushing (24), ring (10), and pinion stop (11).

(c) Remove snap ring (18) and shift lever stud (18).

(d) Remove shift lever housing (12). Pull pin (18) and release plunger assembly (20) from lever assembly (19). Remove clutch (9).

(e) Remove frame (6) and brake washer (7). Pull armature assembly (8) from within coil assembly.

(f) Remove brushes (30), brush spring and brushholder.

(g) Do not remove pole shoes (26), field coils, or coil assembly unless replacement parts are needed.

##### b. Cleaning, Inspection, Repair and Testing.

##### (1) Cleaning.

(a) Use a cloth dampened with an approved solvent to wipe all dust, oil, and other foreign material from the brush plates, end frames, and armature and field assemblies.

(b) Use filtered compressed air to blow dust and dirt from the crevices of the armature and field windings.

(c) Secure armature in a lathe with armature spinning, hold a sheet of No. 000 sandpaper against the commutator until the copper is bright and smooth.

##### (2) Inspection.

(a) Examine field frame assembly for cracks or warping. Inspect armature shaft end for damage or wear.

(b) Examine clutch for broken or cracked teeth.

(c) Examine field coils for worn, burned, and frayed insulation. Be certain connections between field coils are secure. Repair connections if necessary.

(d) Inspect springs for distortion or fatigue. Examine brushes for damage or excessive wear.

##### (3) Repair.

(a) Replace armature or coils if tests indicate shorts.

(b) If commutator is out-of-round in excess of 0.001 inch turn down on lathe.

(c) Replace damaged or worn solenoid switch.

(d) Replace all parts indicating wear, cracks, or damage.

(e) Undercut mica insulation between the commutator bars to a depth of  $\frac{1}{32}$  of an inch. When undercutting mica, the cut should be square and free of burrs.

##### (4) Testing.

(a) Check brushholder for shorts to ground using a test light.

(b) Test armature assembly for open coils and shorts to ground, or between coils by using a test light.

(c) Check field coils for open circuits and shorts to ground, or between coils using a test light.

##### c. No-Load Test.

(1) Connect the starting motor to a 24 volt dc supply. With an ammeter and voltmeter connected in the circuit, apply voltage to the starting motor.

(2) With the starting motor armature turning approximately 6,000 rpm, the ammeter should indicate 42 amperes. The voltmeter should be indicating 23 volts.

*Note.* The performance of the starter should conform to the curves indicated in MS 53013.

##### d. Reassembly and Installation.

(1) Reassembly is the reverse of disassembly, refer to figure 6-2.

(2) Installation of the starter assembly is the reverse of removal (para 3-57).



## CHAPTER 7

### AIR COMPONENT REPAIR INSTRUCTIONS

---

#### Section I. COMPRESSOR ASSEMBLY

##### 7-1. General

The compressor on the lubricating unit is a two-stage, 28 cfm unit. The twin-cylinder construction gives a higher discharge pressure with less consumption of power. The larger cylinder is a low pressure cylinder and the smaller is the high pressure cylinder. The low pressure, or first stage, exhausts air into an intercooler which cools the air before it enters under pressure (45 psi) into the high pressure cylinder. The compressor is equipped with an oil monitor which affords maximum protection against damage due to insufficient oil in the crankcase, however, the splash-type lubrication system provides adequate lubrication, even if the oil level in the reservoir is low. The compressor is equipped with an automatic pressure control which unloads the compressor when the tank pressure has reached 175 psi and allows compression to resume when pressure has dropped to 145 psi. A centrifugal unloader automatically opens a valve releasing compression from cylinders, intercooler and after cooler each time the compressor stops.

Air is exhausted outside the crankcase where moisture cannot contaminate the lubricant.

##### 7-2. Compressor

*a. Removal.* Remove the compressor assembly as instructed in paragraph 3-97.

*b. Disassembly.* Remove the compressor air cleaner (para 3-98) and disassemble the compressor in the numerical sequence as illustrated in figures 7-1 through 7-3.

*c. Cleaning.*

(1) Wash all parts of compressor assembly, except bearings and gaskets in dry cleaning solvent. Dry the parts with clean, lint-free cloths and place in covered containers. Use a small brush to swab out the lubricating oil passages in the crankcase.

(2) Wash bearings in filtered dry cleaning solvent, then dry using the vacuum air method. Lubricate bearings immediately after cleaning.

**Warning: Avoid touching clean bearings with bare fingers; do not spin bearing while dry.**

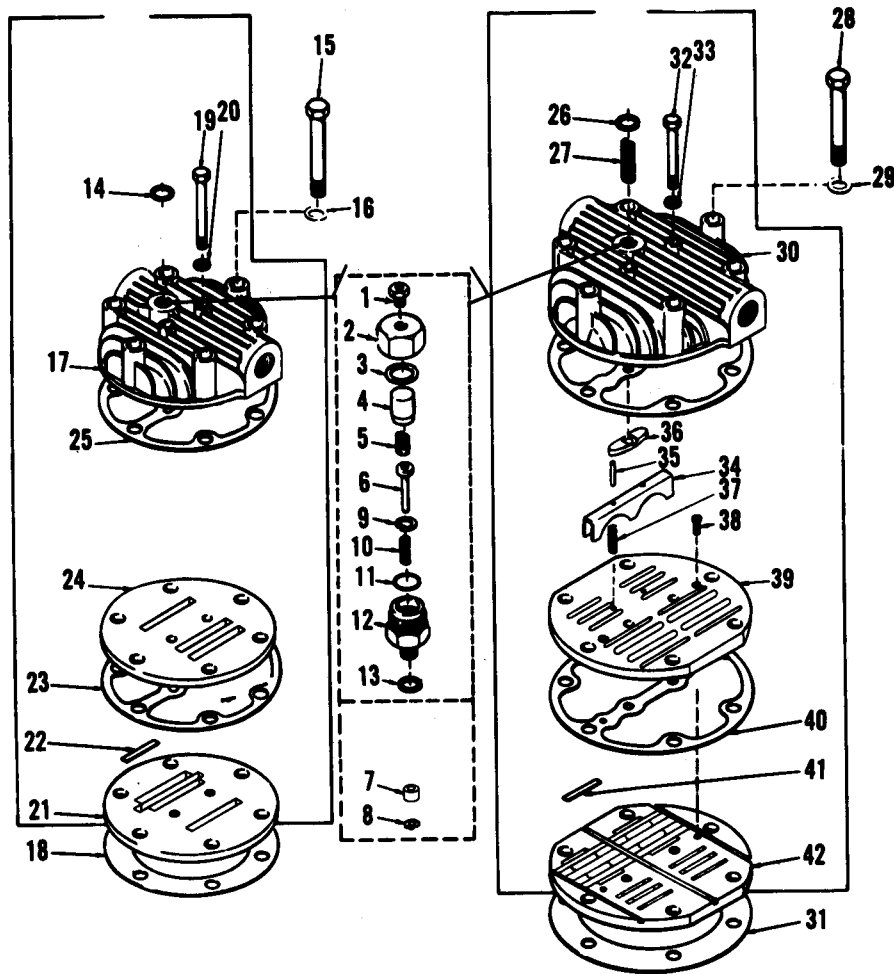

MEC 4930-217-14/7-1

- |                           |                        |                         |
|---------------------------|------------------------|-------------------------|
| 1 Bushing                 | 16 Washer (6)          | 29 Washer (6)           |
| 2 Cap                     | 17 H. P. cylinder head | 30 Head cylinder, l. p. |
| 3 Gasket                  | 18 Gasket              | 31 Gasket               |
| 4 Piston                  | 19 Screw               | 32 Screw                |
| 5 Spring                  | 20 Washer              | 33 Washer               |
| 6 Stem assy               | 21 Plate, lower        | 34 Unloader finger      |
| 7 Collar                  | valve h. p.            | 35 Pin (2)              |
| 8 Ring                    | 22 Strip               | 36 Beam                 |
| 9 Ring                    | 23 Gasket              | 37 Spring (2)           |
| 10 Spring                 | 24 Plate, upper        | 38 Screw (2)            |
| 11 O-ring                 | valve h. p.            | 39 Plate                |
| 12 Body and cap assy      | 25 Gasket              | 40 Gasket               |
| 13 Gasket, L.P. unloader  | 26 Gasket              | 41 Strip                |
| 14 Gasket, H. P. unloader | 27 Spring              | 42 Plate                |
| 15 Screw (6)              | 28 Screw (6)           |                         |

Figure 7-1. Compressor cylinder head.

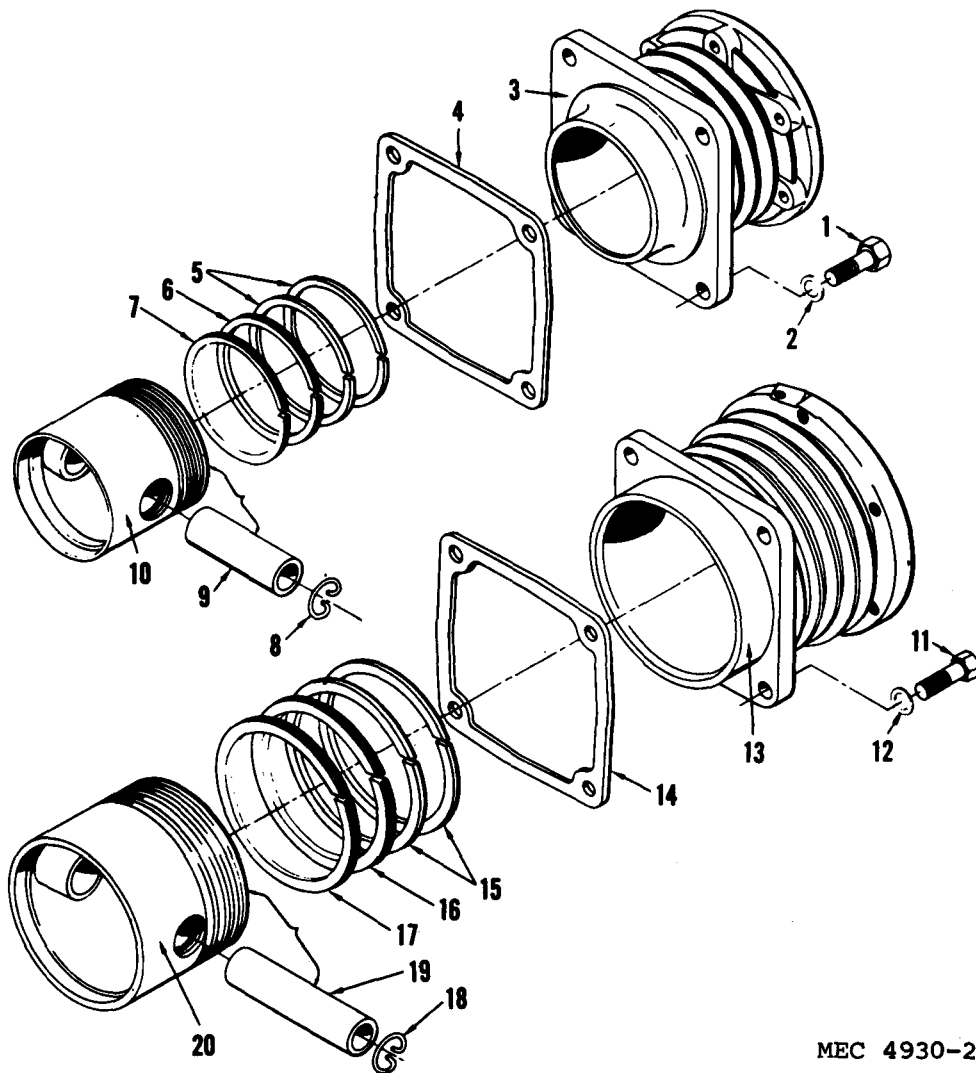

MEC 4930-217-14/7-2

- |                           |                    |                            |
|---------------------------|--------------------|----------------------------|
| 1 Screw                   | 8 Ring             | 15 Compression ring        |
| 2 Gasket                  | 9 Pin              | 16 Ring oil control, l. p. |
| 3 Cylinder, h. p.         | 10 Piston          | 17 Ring oil control, h. p. |
| 4 Gasket                  | 11 Screw           | 18 Piston pin lock ring    |
| 5 Ring compression, h. p. | 12 Gasket          | 19 Piston pin              |
| 6 Ring oil control, h. p. | 13 Cylinder, l. p. | 20 Piston, l. p.           |
| 7 Ring oil control, h. p. | 14 Gasket          |                            |

Figure 7-2. Compressor cylinders and pistons.

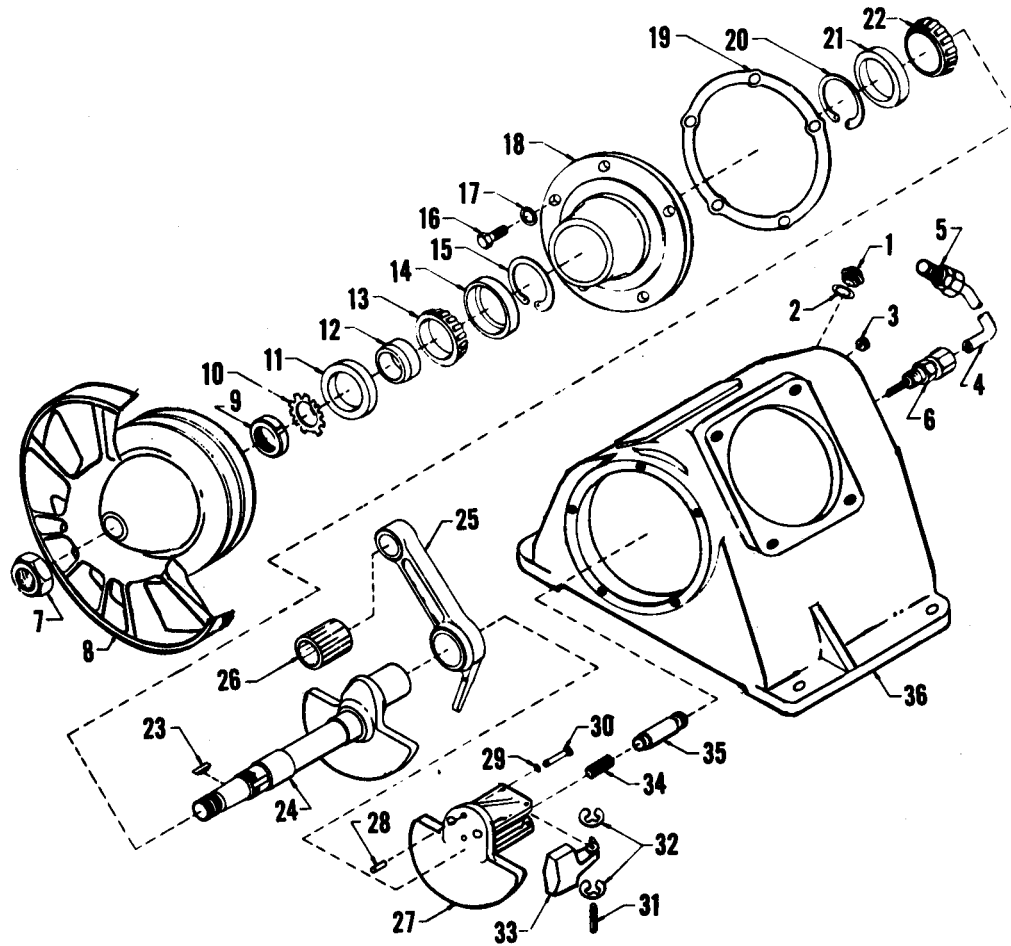

MEC 4930-217-14/7-3

- |             |            |                  |                |
|-------------|------------|------------------|----------------|
| 1 Plug      | 10 Washer  | 19 Gasket        | 28 Pin         |
| 2 Gasket    | 11 Seal    | 20 Ring          | 29 Washer      |
| 3 Plug      | 12 Sleeve  | 21 Cup           | 30 Screw       |
| 4 Tubing    | 13 Cone    | 22 Cone          | 31 Pin         |
| 5 Connector | 14 Cup     | 23 Key           | 32 Ring        |
| 6 Valve     | 15 Ring    | 24 Crankshaft    | 33 Leverweight |
| 7 Nut       | 16 Screw   | 25 Rod           | 34 Spring      |
| 8 Flywheel  | 17 Gasket  | 26 Bearing       | 35 Plunger     |
| 9 Nut       | 18 Housing | 27 Counterweight | 36 Crankcase   |

Figure 7-3. Compressor base assembly.

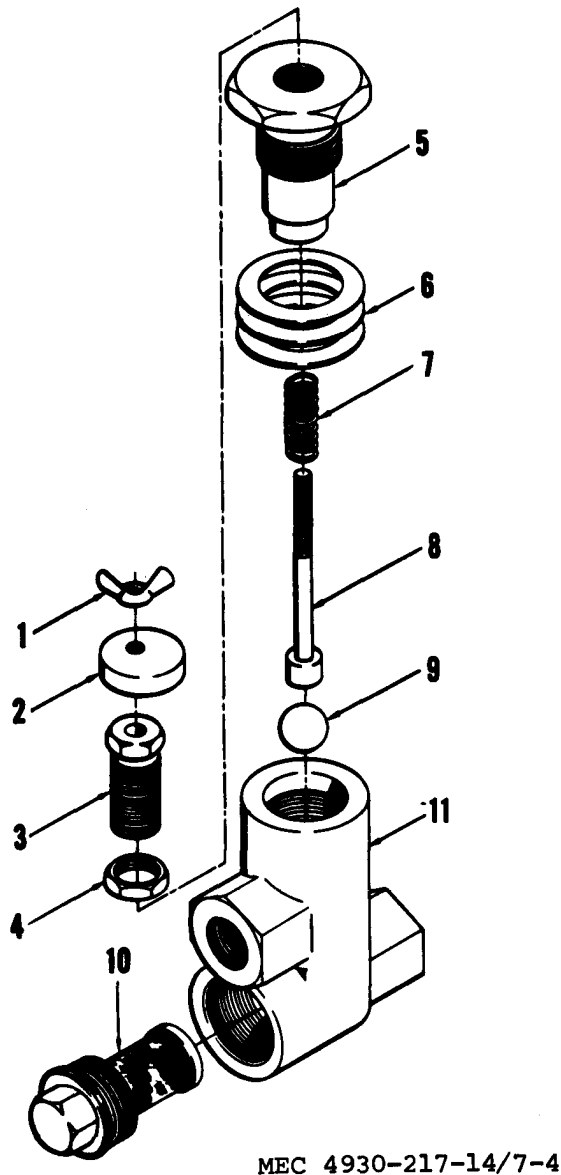

- |                   |           |
|-------------------|-----------|
| 1 Wing nut        | 7 Spring  |
| 2 Adjusting nut   | 8 Stem    |
| 3 Adjusting screw | 9 Ball    |
| 4 Jam nut         | 10 Holder |
| 5 Retainer        | 11 Body   |
| 6 Shim            |           |

Figure 7-4. Compressor relief valve.

## Section II. COMPRESSOR RELIEF VALVE

### 7-3. General

The compressor relief valve is a pressure regulated device which transmits receiver pressure to the suction valve unloaders when

### d. Inspection.

(1) Perform a thorough general inspection of all parts of the compressor assembly, checking particularly for cracked and chipped casting, damaged screw threads, and finished surfaces that are scored, pitted, or scratched.

(2) Inspect connecting tube assemblies and fittings for worn or damaged screw threads, cracks, dents, sharp bends, and other defects. Pay particular attention to the flare ends of the tubes since cracking is most apt to occur at the root of the flare. Do not attempt to reclaim a connecting tube assembly by replacing component parts.

(3) Inspect cylinder bores, pistons, connecting rods, and pins for excessive wear, scoring, and other indications of damage. Discard all damaged and excessively worn parts.

(4) Inspect valves, valve seats, valve springs, and stops for nicks, scoring, burning, warping, and noticeable wear. Discard all worn or damaged parts.

(5) Replace all gaskets.

e. *Repair.* The repair of component parts or subassemblies of the compressor assembly should not be attempted. Discard all damaged, worn, and questionable parts and install new items during reassembly of the equipment.

f. *Reassembly.* Reassemble the compressor in reverse of numerical sequence as illustrated in figures 7-1 through 7-3.

g. *Installation.* Install the compressor assembly as instructed in paragraph 3-97.

the pressure reaches the high limit thereby unloading the compressor. When the receiver pressure drops to the low limit, the valve releases pressure from the suction valve un-

loaders, thereby allowing the suction valves to function normally.

#### **7-4. Compressor Relief Valve**

*a. Removal.* Refer to paragraph 3-117 and remove the relief valve.

*b. Disassembly.* Disassemble the compressor relief valve in numerical sequence as shown in figure 7-4.

*c. Cleaning and Inspection.*

(1) Clean all metal parts with an approved cleaning solvent and dry thoroughly.

(2) Inspect for cracks, breaks, worn or damaged threads.

(3) Replace a damaged or defective part.

*d. Reassembly.* Reassemble the relief valve

in reverse numerical sequence as shown in figure 7-4.

*e. Adjustment.* The pressure differential (range between opening and closing pressures) should be adjusted to about 10 percent of the cutout pressure (above 175 psi).

(1) The cutout pressure is adjusted by loosening the jam nut (4, fig. 7-4) and turning the adjusting screw (3), in to increase, and out to decrease the pressure. The jam nut should then be retightened.

(2) Pressure differential pressure adjustment is made by unscrewing the spring retainer (5), and either adding shims (6), to decrease or removing shims to increase the differential.

*f. Installation.* Refer to paragraph 3-117 and install the compressor relief valve.

## CHAPTER 8

### LUBRICATING EQUIPMENT REPAIR INSTRUCTIONS

---

#### Section I. LUBRICATING UNIT PUMPS (Used on Serial Numbers 69-29737 through 69-29942)

#### 8-1. General

The air powered pumps are mounted opposite the hose reel bank assembly. A high pressure, 60 to 1 ratio pump is mounted on the center lubricant container and one 10 to 1 ratio low pressure pump is mounted on each of the two outside lubricant containers. The pumps are heavy duty piston type designed for volume operation under extreme conditions.

#### 8-2. High Pressure Pump

*a. Removal.* Remove the high pressure pump as instructed in paragraph 3-1114.

*b. Disassembly.* Disassemble the high pressure pump in the numerical sequence as illustrated in figure 8-1.

*c. Inspection.*

(1) Clean all parts in an approved cleaning solvent.

(2) Inspect and replace any worn or damaged parts.

(3) Inspect threaded surfaces for damage.

(4) Replace all parts supplied in parts kit.

*d. Repair.*

(1) Clean ball seat and primer valve as follows:

(a) Remove primer cylinder (17, fig. 8-1B) and high pressure cylinder (1) using pipe wrench.

*Note.* Primer valve assembly will come off when high pressure cylinder is removed.

(b) Remove retaining ring (12), washer (13), packing (14) and backup washer (15). Replace packing (14) and backup washer (15) as necessary.

(c) Unscrew nut (22) and pull primer piston (21) off.

(d) Unscrew primer rod (20). Remove piston (11) from piston nut (7). Inspect packings (8 and 10) and backup washer (9), replace if necessary.

(e) Remove piston nut (7) and tap out ball (6) and spring (5). Clean ball and piston nut thoroughly. Reseat ball using soft metal rod and tapping lightly with small hammer.

(2) Replace packings (6, 7 and 8, fig. 8-1A) as follows:

(a) Disassemble tube and rod assembly as outlined in step 8-2d (1).

(b) Unscrew pump tube (3, fig. 8-1B). Remove outlet body assembly and drain valve assembly.

(c) Remove six screws (2, fig. 8-1A) and mounting plate (3). Loosen rod (2, fig. 8-1B) and remove complete rod and high pressure cylinder support assembly.

*Note.* It may be necessary to loosen cylinder cap (4, fig. 8-1C) and pull out and hold air piston assembly.

(d) Place high pressure cylinder support (4, fig. 8-1A) in vise and remove nut (9). Remove female packing ring (8), six V-packings (7) and male packing ring (6).

(e) Inspect and replace damaged or worn parts.

*Note.* Soak V-packings (7) in oil before installing.

(f) Remove O-ring (10), inspect and replace if necessary.

(3) Remove O-ring or valves in air piston as follows:

(a) Disassemble as outlined in steps 8-2d(1)(2).

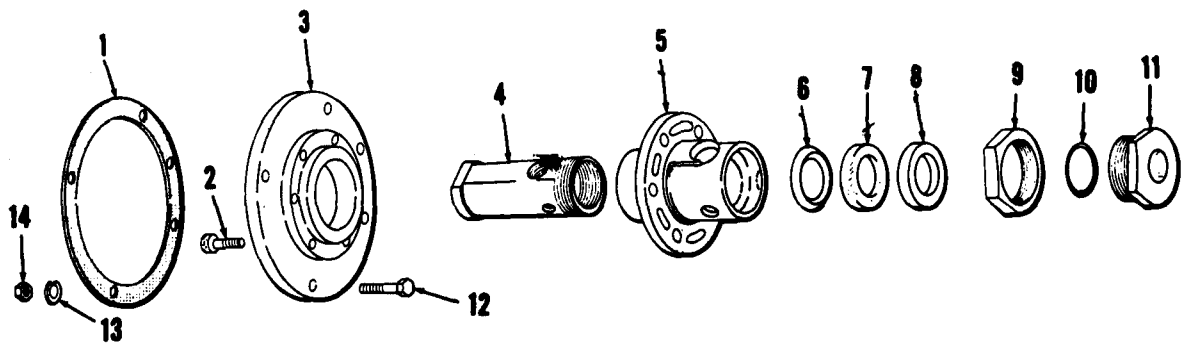

A. HIGH PRESSURE PUMP MOUNTING PLATE AND ADAPTER

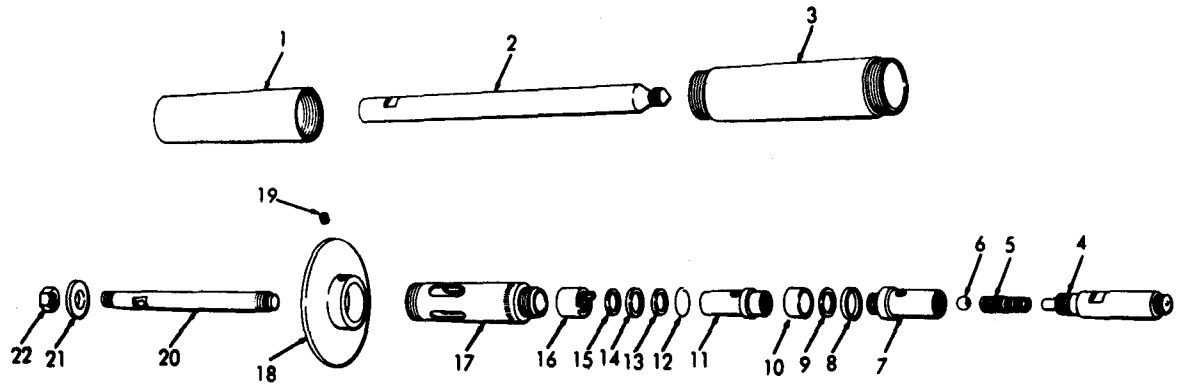

B. HIGH PRESSURE PUMP TUBE

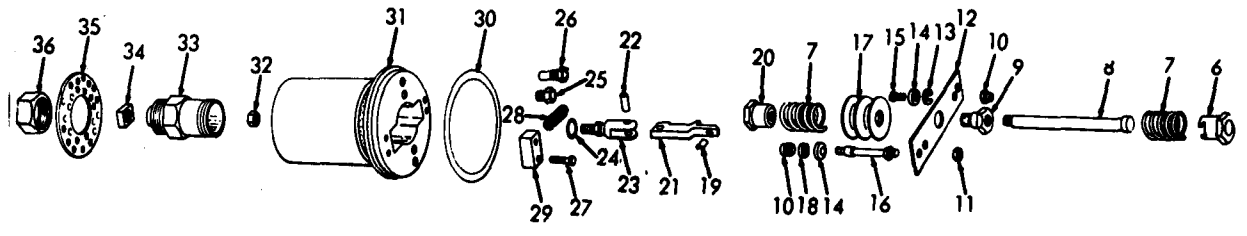
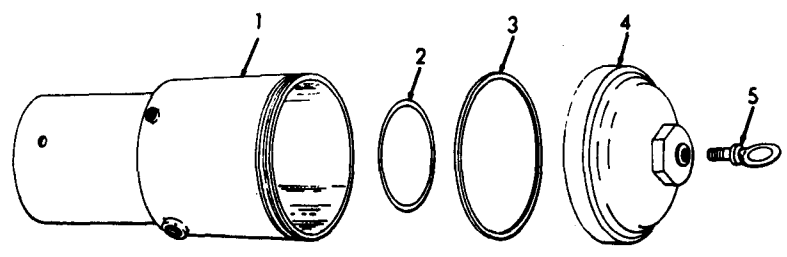

C. HIGH PRESSURE PUMP AIR CYLINDER

MEC 4930-217-14/8-1

Figure 8-1. High pressure lubrication pump  
(Used only on Serial Numbers 69-29737  
through 69-29942).



1 Pump mounting gasket	6 Male packing ring	11 Packing nut
2 Socket head cap screw (6)	7 V-packing (6)	12 Mounting bolt (5)
3 Mounting plate	8 Female packing ring	13 Lockwasher (5)
4 High-pressure cylinder support	9 Clamp nut	14 Nut (5)
5 Pump adapter	10 O-ring	
1 High-pressure cylinder	9 Backup washer	16 Primer valve
2 Upper pump rod	10 Piston packing	17 Primer cylinder
3 Pump tube	11 Piston	18 Primer cylinder plate
4 Lower pump rod	12 Retaining ring	19 Setscrew
5 Spring	13 Washer	20 Primer rod
6 Ball bearing	14 Preformed packing	21 Primer piston
7 Piston nut	15 Primer valve backup washer	22 Nut
8 Packing		
1 Air cylinder housing	13 Exhaust valve washer (2)	25 Exhaust valve seat (2)
2 Air cylinder packing	14 Air valve (4)	26 Intake valve seat (2)
3 Air cylinder gasket	15 Exhaust valve stem (2)	27 Cap screw (4)
4 Cylinder cap	16 Intake valve stem (2)	28 Trip spring (2)
5 Eyebolt	17 Valve shifter sleeve	29 Trip spring bearing (2)
6 Top valve spring stop	18 Valve washer (2)	30 Air piston gasket
7 Valve spring	19 Roll pin	31 Air piston
8 Valve shifter rod	20 Lower valve spring stop	32 Nut (2)
9 Valve shifter	21 Trip valve	33 Air piston stem
10 Elastic stop nut (4)	22 Trip pin (2)	34 Square nut
11 Nut (2)	23 Trip fulcrum (2)	35 Exhaust muffler plate
12 Valve bar	24 Trip fulcrum gasket (2)	36 Clamp nut

Figure 8-1.—Continued.

(b) Grasp hex cap on cylinder cap (4, fig. 8-1C) and unscrew from air cylinder housing (1). Pull out exposed valve spring (7) and top valve spring stop (6) by placing large screwdriver in coils of spring (7) and prying downward so spring snaps off top valve spring stop (6).

(c) Valve shifter rod (8) will slide out at keyhole slot in top valve spring stop (6) and cylinder cap may be removed. Pull complete air piston assembly out of air cylinder.

(d) Examine packing (2), gasket (30) and air valve (14).

(e) If worn or damaged, remove four screws (27) holding trip spring bearing (29) to air piston (31).

(f) Remove springs (28) and trip spring bearing (29). Remove two nuts (10) on end of valve stem (15).

(g) Remove washers (13) and air valve (14). Grasp valve bar (12) and pull out of air piston; remove air valve (14).

(h) Reassemble in reverse order.

*Note.* Be sure spring (7) is snapped in place on top valve spring stop (6).

*Note.* Before replacing cylinder cap (4), replace tube adapter and rod in order to tighten rod in air piston securely.

*e. Reassembly.* Reassembly is essentially the reverse of disassembly.

*f. Instalation.* Refer to paragraph 3-114 and install the pump.

### 8-3. Low Pressure Pump (Used on Serial Numbers 69-29737 through 69-29942)

*a. Removal.* Remove the low pressure pump as instructed in paragraph 3-114.

*b. Disassembly.* Disassemble the low pressure pump in the numerical sequence as illustrated in figure 8-2.

*Note.* The low pressure pump air cylinder is identical to the high pressure pump air cylinder. See figure 8-1C and disassemble in numerical sequence.

*c. Cleaning and Inspection.*

(1) Clean all parts in an approved cleaning solvent.

(2) Inspect and replace any worn or damaged parts.

(3) Inspect threaded surfaces for damage.

(4) Replace all parts supplied in parts kit.

*d. Repair.*

(1) To clean foot valve and transfer valve proceed as follows:

(a) To clean foot valve, unscrew foot valve assembly, then remove retaining ring (11, fig. 8-2A) and ball (12). Clean ball and body thoroughly and replace.

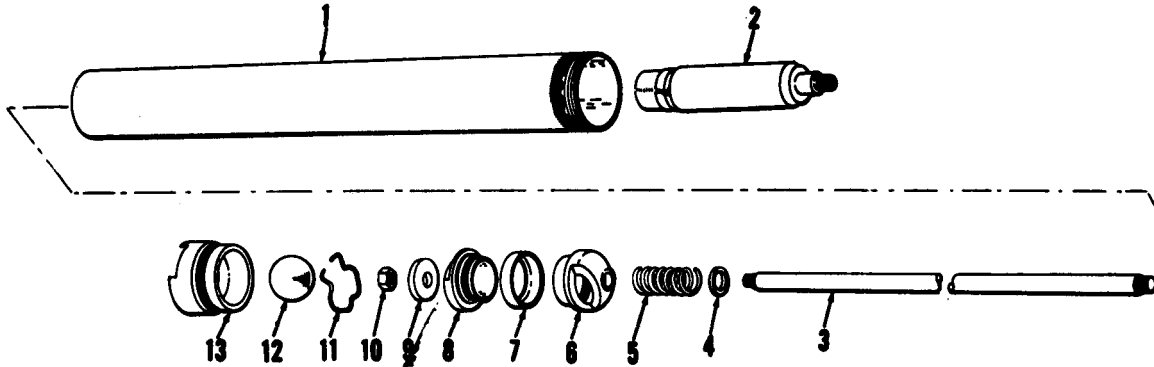

A. LOW PRESSURE PUMP TUBE

B. LOW PRESSURE PUMP ADAPTER AND MOUNTING PLATE

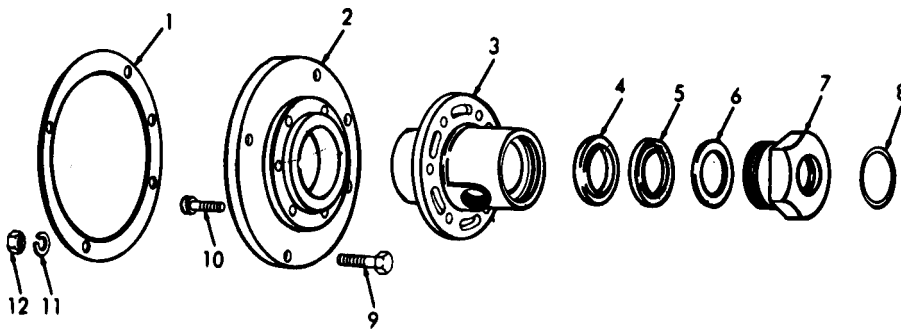

MEC 4930-217-14

- |                         |                     |                             |
|-------------------------|---------------------|-----------------------------|
| 1 Pump tube             | 6 Piston            | 10 Nut                      |
| 2 Upper pump rod        | 7 Leather cup       | 11 Ball retaining ring      |
| 3 Lower pump rod        | 8 Piston nut        | 12 Ball                     |
| 4 Spring stop           | 9 Piston valve      | 13 Foot valve body          |
| 5 Valve spring          |                     |                             |
| 1 Mounting plate gasket | 5 V-packing (4)     | 9 Mounting plate cap screw  |
| 2 Mounting plate        | 6 Male packing ring | 10 Socket hd. cap screw (6) |
| 3 Pump adapter          | 7 Packing nut       | 11 Lockwasher (5)           |
| 4 Female packing ring   | 8 O-ring            | 12 Nut (5)                  |

Figure 8-2. Low pressure lubrication pump  
(Used on Serial Numbers 69-29737  
through 69-29942).

(b) To clean transfer valve, remove pump tube (1), nut (10) and piston valve (9); then pull piston assembly off pump rod. Inspect leather cup (7); replace if damaged or worn by unscrewing piston nut (8) from piston (6). Inspect valve and seat if damaged. Polish with fine emery cloth.

(2) To replace seals between tube (1, figure 8-2A) and pump adapter (3, figure 8-2B) proceed as follows:

(a) Disassemble as outlined in step 8-3d(1).

(b) Remove spring (5, fig. 8-2A) and spring stop (4), remove six screws (10, fig. 8-2B) and plate (2).

(c) Unscrew rod (3, fig. 8-2A) and remove rod and tube adapter assembly (3 through 8, fig. 8-2B).

*Note.* It may be necessary to loosen cylinder cap and pull out and hold air piston assembly in order to loosen pump rod.

(d) Remove nut (7, fig. 8-2B) from pump adapter (3). Remove male packing ring (6), four V-packing rings (5), female packing ring (4) and O-ring (8). Inspect and replace damaged or worn parts. Reassemble in reverse order.

(3) To replace O-ring or valves in air piston, proceed as follows:

(a) Disassemble as outlined in steps 8-3d(1).

(b) Unscrew cylinder cap (4, fig. 8-1C) from housing (1). Pull out to expose top valve spring (7) and top valve spring stop (6). Place large screwdriver in coils of valve spring (7) and pry downward so spring snaps off top valve spring stop (6). Valve shifter rod (8) will then slide out of keyhole slot in top valve spring stop (6) and cylinder cap can be removed. Pull complete air piston assembly out of air cylinder.

(c) Examine packing (2), gasket (80) and air valve (14). If worn or damaged, remove four screws (27) holding trip spring bearing (29) to air piston (31). Remove springs (28) and trip spring bearing (29).

(d) Remove two nuts (11) on bottom end of valve stem (16) then remove washers (18) and air valve (14).

*Note.* Be sure valve spring (7) is snapped in place on top valve spring stop (6). Before replacing cylinder cap (4), replace tube adapter and rod in order to tighten rod in air piston securely.

(e) Grasp valve bar (12) and pull out air piston, remove and replace air valve (14).

*e. Reassembly.* Reassembly is essentially the reverse of disassembly.

*f. Installation.* Refer to paragraph 3-114 and install the low pressure pump.

## Section II. LUBRICATING UNIT PUMPS AND VALVES (Used on Serial Number 84-29943 thru 84-30304 and 86-30305 thru 8&31248)

### 8-4. General

The air powered pumps are mounted opposite the hose reel bank assembly, A 40 to 1 ratio pump is mounted on the center lubricant container and one 12 to 1 ratio pump is mounted on each of the two outside lubricant containers. The pumps are heavy duty, reciprocating, industrial type pumps. Four control valves are attached to the four lubricant hoses leading from the pumps. The high pressure control valves are attached to the hose from the 40 to 1 ratio pump for dispensing grease; and two low pressure control valves are attached to the hoses from the two 12 to 1 ratio pumps for dispensing gear and motor oil.

### 8-5. High and Low Pressure Air Powered Pumps

*a. Removal.* Remove the lubricant pump as instructed in paragraph 3-114.

#### *b. Disassembly.*

*Note.* A liquid sealant is applied to the threads of rod (29, fig. 8-3A) to hold nuts (4 and 26) securely. Special precautions must be observed therefore when disassembling and reassembling these parts.

(1) Remove plug (1, fig. 8-3A) and insert assembly (2) with packing (3) from body (33).

(2) Unthread four screws (17) and remove adapter (18) with the packing (19) from valve body.

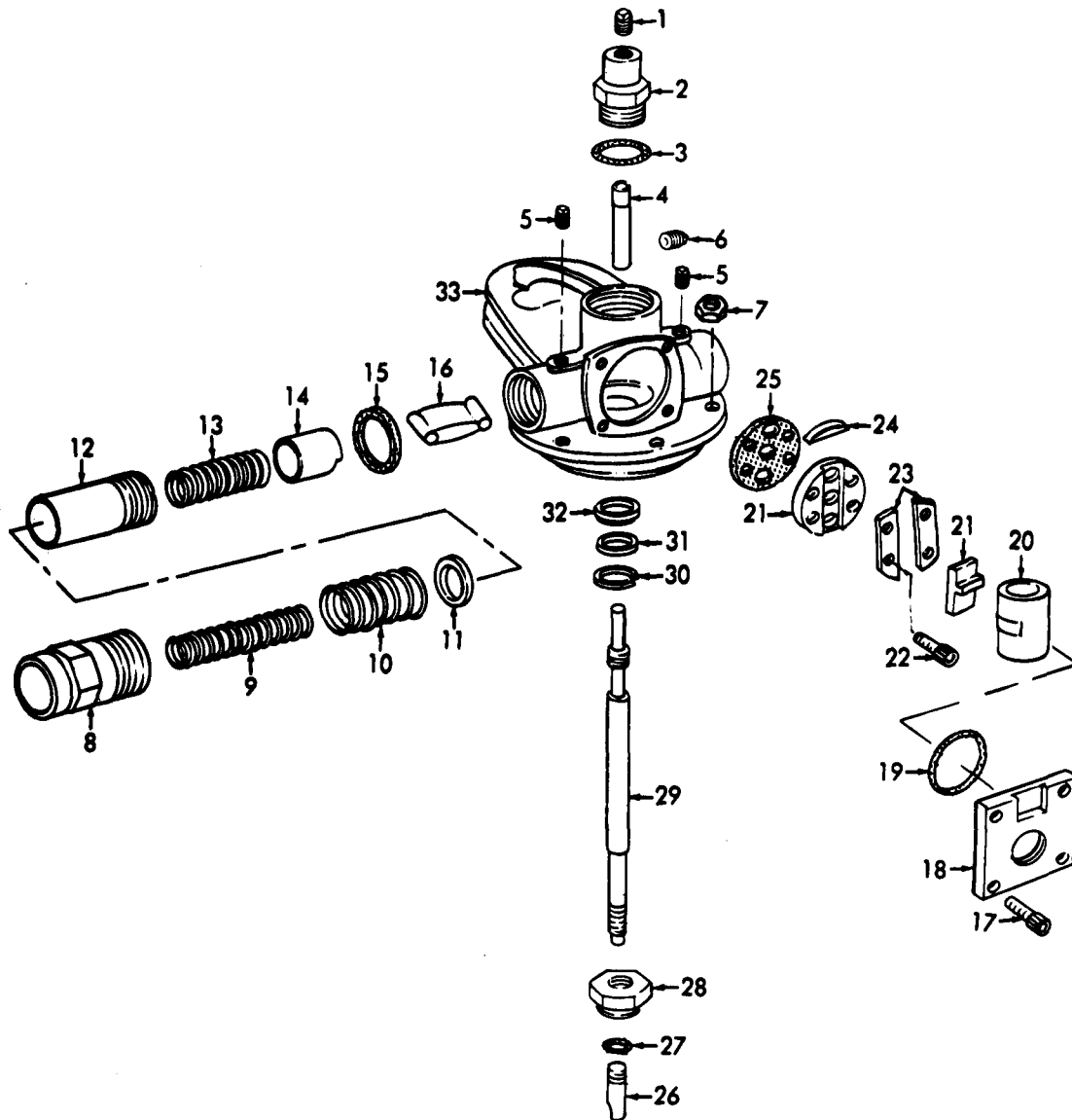

**A. PUMP AIR MOTOR, TOP SECTION**

**MEC 4930-217-14/8-3 ①**

Figure 8-3 ① .High and low pvesure pumps (used only on Serial Numbers 84-29943 through 84-30304 and 86-32805 through 86-31248).

- |               |             |            |                    |
|---------------|-------------|------------|--------------------|
| 1 Plug        | 10 Spring   | 18 Adapter | 26 Nut             |
| 2 Insert assy | 11 Washer   | 19 Packing | 27 Packing         |
| 3 Packing     | 12 Cylinder | 20 Shuttle | 28 Retainer        |
| 4 Nut         | 13 Spring   | 21 Slide   | 29 Piston trip rod |
| 5 Screw       | 14 Plunger  | 22 Screw   | 30 Ring            |
| 6 Plug        | 15 Gasket   | 23 Guide   | 31 Washer          |
| 7 Nut         | 16 Toggle   | 24 Stop    | 32 Block           |
| 8 Cap         | 17 Screw    | 25 Gasket  | 33 Body            |

Figure 8-3.—Continued.

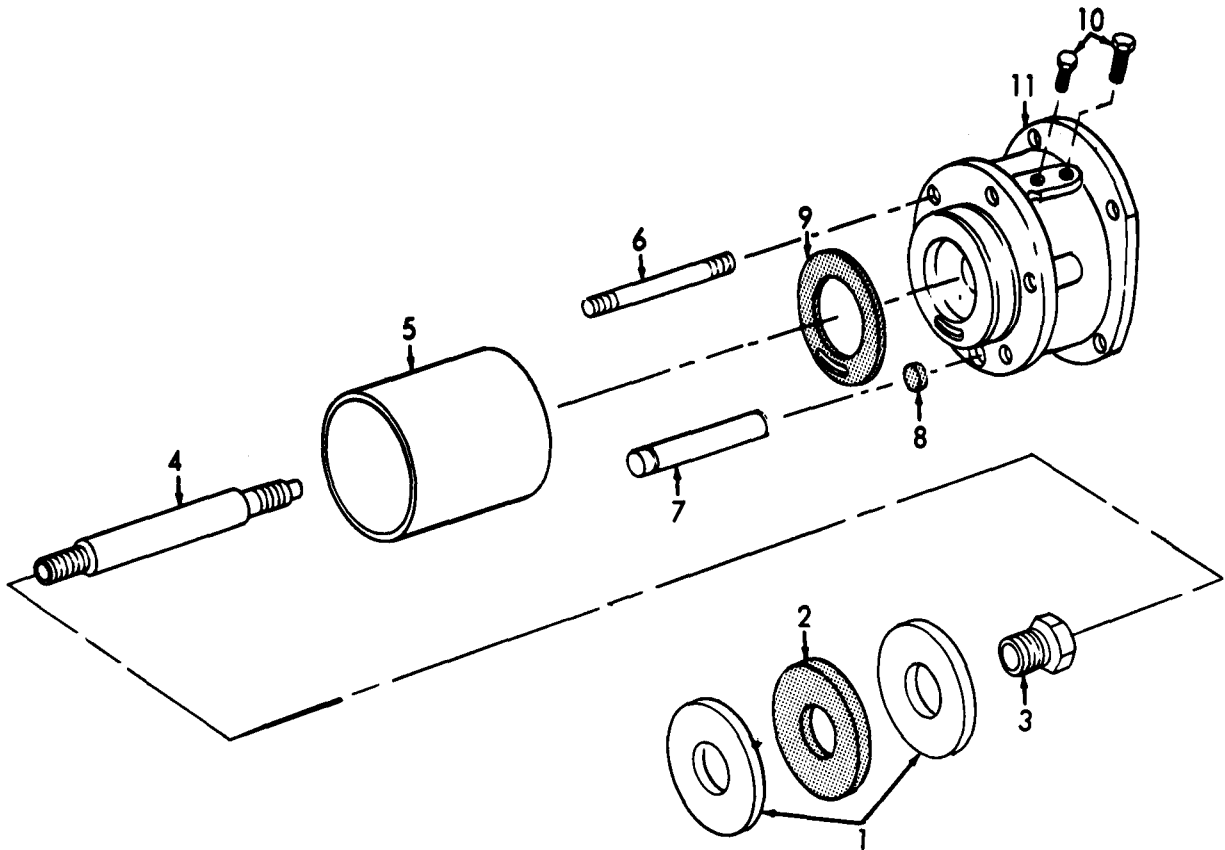

B. PUMP AIR MOTOR, BOTTOM SECTION

MEC 4930-217-14/8-3 ②

- |           |            |           |          |
|-----------|------------|-----------|----------|
| 1 Washer  | 4 Tube     | 7 Tube    | 10 Screw |
| 2 Packing | 5 Cylinder | 8 Packing | 11 Head  |
| 3 Nut     | 6 Rod      | 9 Packing |          |

Figure 8-3②—Continued.

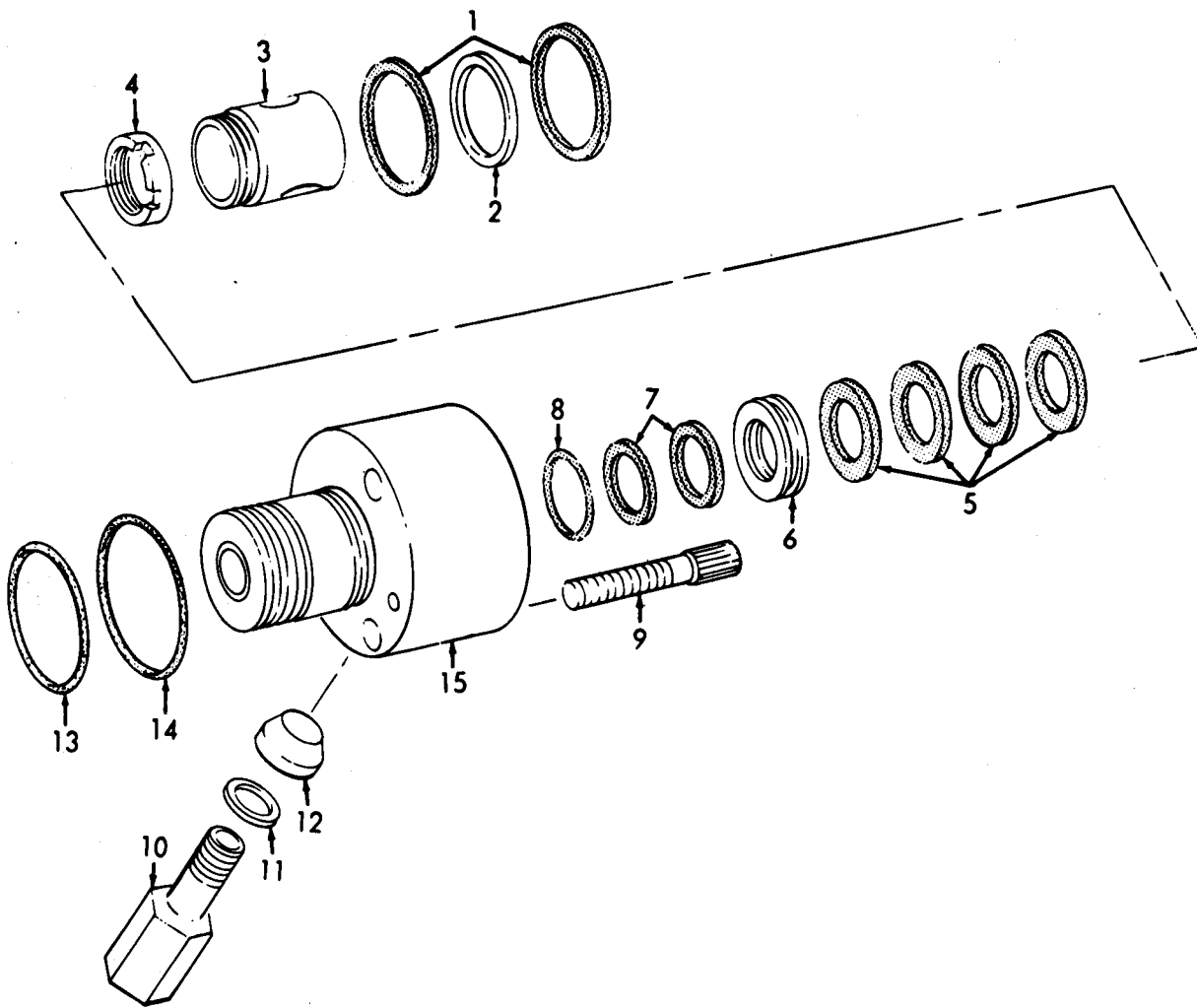

C. PUMP PACKING GROUP

MEC 4930-217-14/8-3 ③

- 1 Gasket
- 2 Washer
- 3 Spacer
- 4 Bearing

- 5 Packing
- 6 Ring
- 7 Packing
- 8 Pack

- 9 Screw
- 10 Adapter
- 11 Washer
- 12 Bushing

- 13 Packing
- 14 Packing
- 15 Body

Figure 8-3③—Continued.

(3) Move piston trip rod assembly (29) to the UP position.

(4) Place a  $\frac{3}{8}$  inch open end wrench on the flats of the nut (4).

(5) Cover the rod with cloth and insert a slip joint pliers through adapter opening and grasp trip rod assembly (29) above the shoulder.

**Caution: Do not scratch the chrome finish on trip rod assembly.**

(6) Use a  $\frac{3}{8}$  inch open end wrench and turn counterclockwise to remove nut (4, fig. 8-3A) from the trip rod assembly (29).

(7) The remaining parts of the air motor can then be disassembled into its component parts (2 through 33, fig. 8-3A and 1 through 11, fig. 8-3B).

(8) The body and packing group can be disassembled as shown (1 through 15, fig. 8-3C).

(9) The high pressure tube (fig. 8-3F) of the 40 to 1 ratio pump can be disassembled as shown (1 through 22).

(10) The low pressure tube (fig. 8-3E) of the 12 to 1 ratio pump can be disassembled as shown (1 through 13).

(11) The circulating valve can be disassembled as shown (1 through 10, fig. 8-3D).

*c. Inspection and Repair,*

(1) Clean all parts in an approved cleaning solvent.

(2) Inspect and replace any worn or damaged parts.

(3) Inspect threaded surfaces for damage.

(4) Replace all parts supplied in parts kit.

*d. Reassembly.* Reassembly is essentially the reverse of disassembly with the following precautions to be as follows:

(1) Clean the threads of trip rod (29, fig. 8-3A) thoroughly before applying liquid sealant.

(2) Apply liquid sealant to threads of trip rod (29) from which nuts have been removed.

(3) Reassemble trip rod with slip joint pliers and  $\frac{3}{8}$  inch open end wrench.

(4) When a new seat valve is installed in the air motor, items 21, 22, 23 and 24 should be assembled with the letter "T" in the UP position.

*e. Installation.* Refer to paragraph 3-114 for installation of the lubricant pumps.

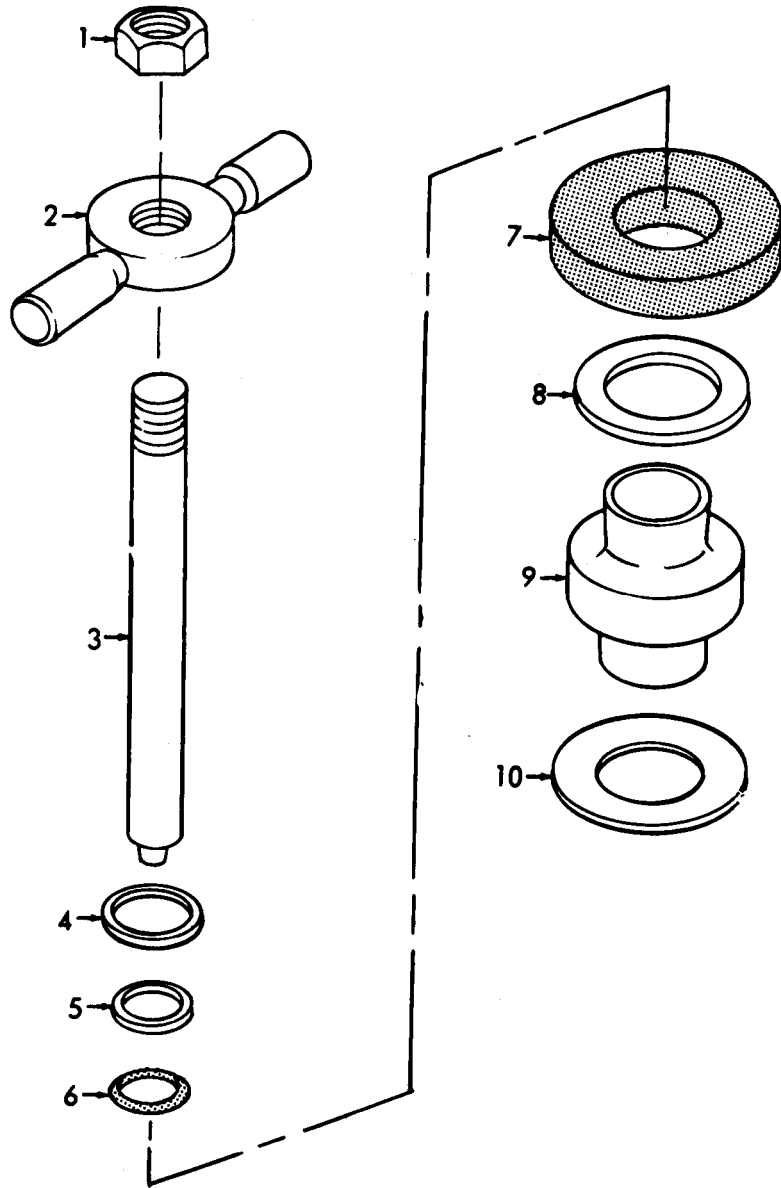

D. PUMP CIRCULATING VALVE

MEC 4930-217-14/8-3 (4)

Figure 8-3(4)—Continued.



- 1 Nut
- 2 Handle
- 3 Stem

- 4 Ring
- 5 Washer
- 6 Packing

- 7 Packing
- 8 Washer

- 9 Cap
- 10 Washer

Figure 8-3④—Continued.

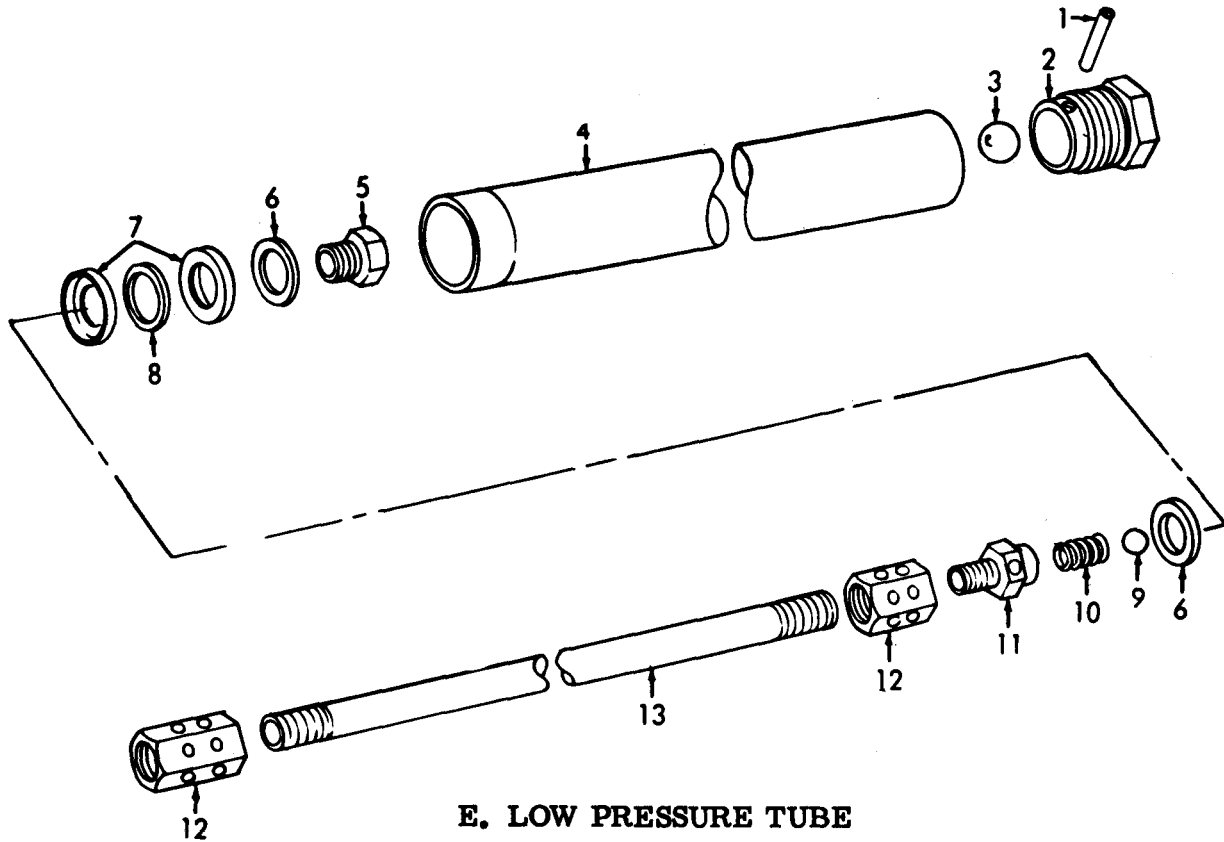

E. LOW PRESSURE TUBE

MEC 4930-217-14/8-3 ⑤

- 1 Pin
- 2 Body
- 3 Ball
- 4 Tube

- 5 Seat
- 6 Washer
- 7 Cup

- 8 Plate
- 9 Ball
- 10 Spring

- 11 Adapter
- 12 Coupling
- 13 Rod

Figure 8-3⑤—Continued.

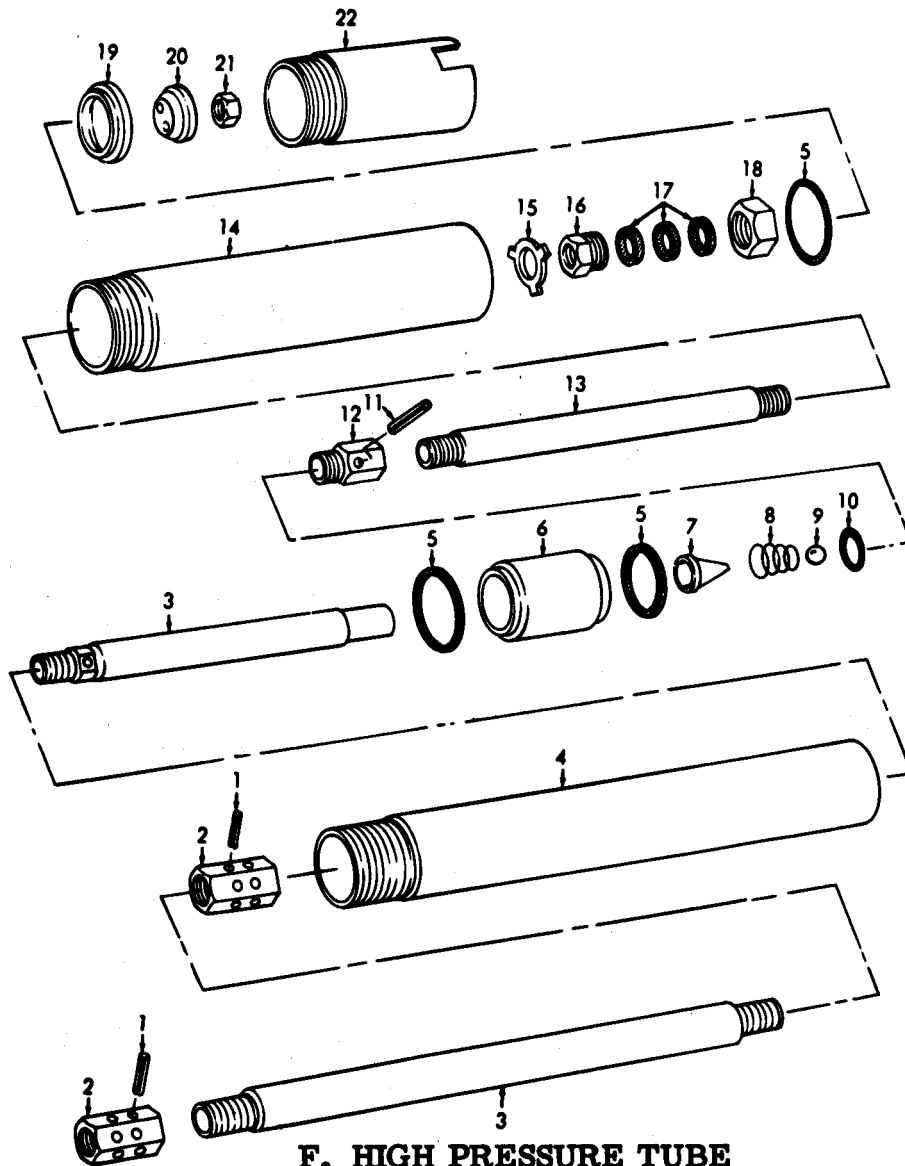

**F. HIGH PRESSURE TUBE**

MEC 4930-217-14/8-3 (6)

- |            |            |            |            |          |
|------------|------------|------------|------------|----------|
| 1 Clip     | 6 Piston   | 11 Pin     | 15 Washer  | 19 Seat  |
| 2 Coupling | 7 Retainer | 12 Adapter | 16 Screw   | 20 Plate |
| 3 Rod      | 8 Spring   | 13 Rod     | 17 Packing | 21 Nut   |
| 4 Tube     | 9 Ball     | 14 Adapter | 18 Body    | 22 Body  |
| 5 Gasket   | 10 Washer  |            |            |          |

Figure 8-3(6)—Continued.

**Section III. TRANSFER PUMP**  
**(Used on Serial Numbers 69-29737 through 69-29942)**

**8-6. General**

The transfer pump is an air operated device used for transferring lubricants from original drums to the lubricant storage tanks.

**8-7. Transfer Pump**

*a. Removl.* Remove transfer pump (para 2-14).

*b. Disassembly.* Disassemble the transfer pump in the numerical sequence as illustrated in figure 3-4.

*c. Cleaning and Inspection.*

(1) Clean all parts using an approved cleaning solvent.

(2) Check to see that foot valve is clean and free from all dirt and foreign matter.

(3) Check to see that air coupler is clean and operates easily.

(4) The packings should be replaced periodically.

(5) Inspect pump rods and tubes for bends, breaks or other defects which would prevent proper operation.

*d. Repair.*

(1) If pump is not operating, air piston tube not moving, or air blowing constantly from piston rod adapter, proceed as follows:

(a) Remove air cylinder assembly (3), then pull air piston (10) to the extreme outward position.

(b) Using heel of hand, push on upper valve plate (8), holding air piston in other hand so as to expose O-rings (12). Replace O-rings if damaged.

(c) Inspect O-ring (9) by pulling out on upper valve plate, replace if necessary, by removing three nuts (5) under lower valve plate (13); then pulling O-rings through ports on air piston. Reassemble in reverse order.

(d) Inspect O-ring (11) for wear. Re-

place if necessary. Screw air cylinder in place making sure valve springs (14) are in proper position in top of cylinder.

(e) If air is leaking around air piston tube, remove air cylinder assembly (3) and drive out pin (20) located where upper pump rod enters air piston. Unscrew piston from rod and pull out through pump body; then replace O-ring (17). Reassemble in reverse order.

*Note.* Be sure hole in rod lines up with hole in piston adapter. Rod is not tightened all the way in the adapter.

(2) If pump operates with control handle shut off or insufficient delivery with control open, proceed as follows:

(a) Clean foot valve by removing extension tube and unscrew foot valve from lower end of pump tube. Remove retainer (38) and ball (37). Clean ball and body thoroughly, replace.

(b) Clean Transfer valve by unscrewing pump tube (35) from body (21).

*Note.* Grasp pump tube with pipe wrench at extreme lower end to eliminate possibility of denting tube.

(c) Unscrew nut (34), then remove valve (33) and piston (30). Clean thoroughly and inspect valve and piston for scratches or burrs. If necessary, polish with fine emery cloth.

(d) Inspect leather packing (31), replace if necessary by removing piston nut (32) from piston (30). Reassemble in reverse order.

(3) If oil leaks out of Pump body where rod (24) enters, replace packing as follows:

(a) Remove pump tube, transfer piston, etc., as described in step 2.

(b) Remove pin (20) from rod (24). Unscrew rod from air piston. Replace packing (25) and reassemble.

*e. Reassembly.* Reassembly is essentially the reverse of disassembly.

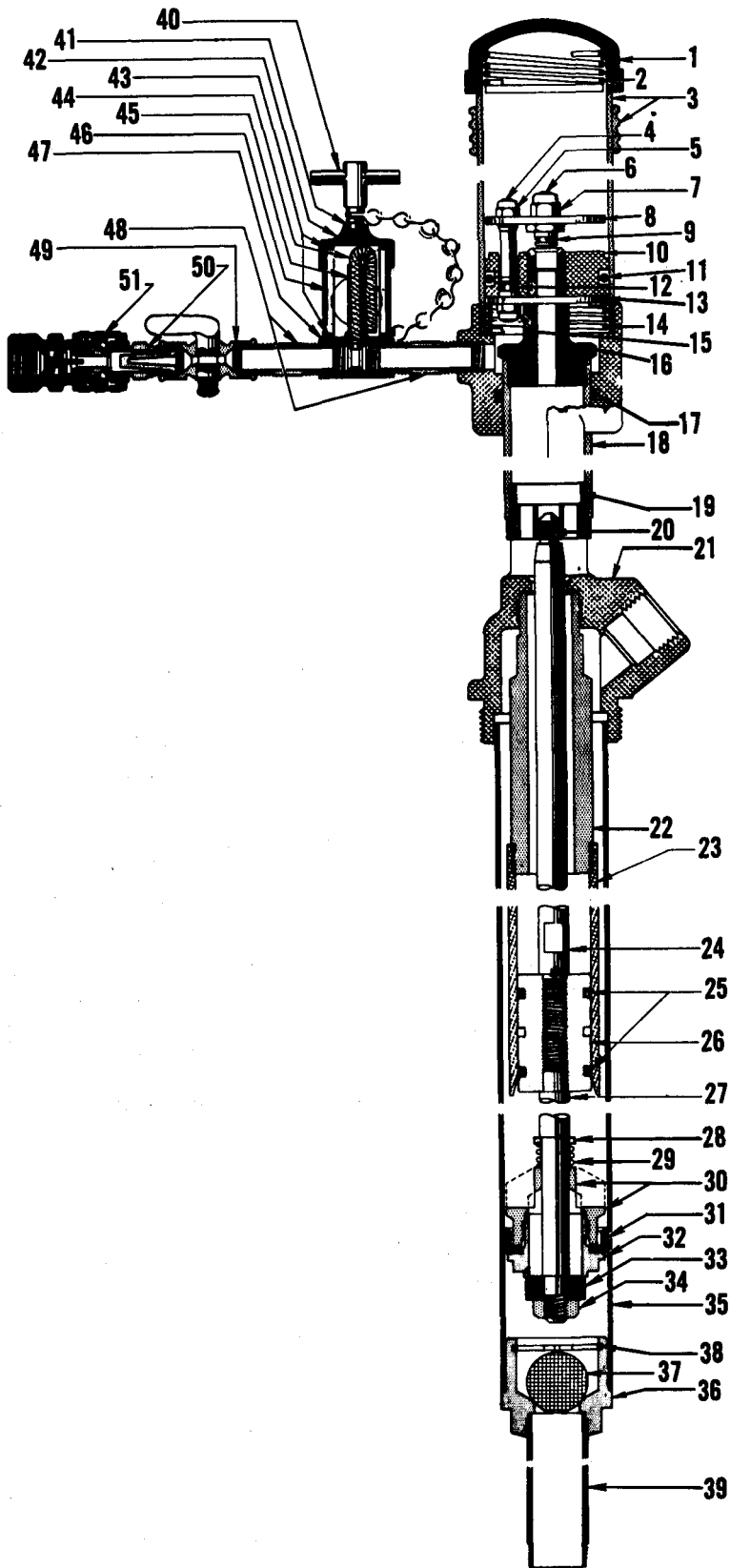

MEC 4930-217-14/8-4

Figure 8-4. Transfer pump (used only on Serial Numbers 69/29737 through 69-29942).

1 Cap	14 Valve spring	27 Rod	40 Filler cap assy
2 Spring	15 Nut	28 Washer	41 O-ring
3 Air cylinder assy.	16 Adapter	29 L. P. spring	42 Head
4 Stem	17 O-ring	30 Piston	43 Gasket
5 Nut	18 Tube	31 Leather packing	44 Wick
6 Stem	19 Adapter	32 Piston nut	45 Tube
7 Nut	20 Pin	33 Valve	46 Tube
8 Upper valve plate	21 Body	34 Nut	47 Body
9 O-ring	22 Support	35 Tube	48 Nipple
10 Air piston	23 Cylinder	36 Body	49 Valve
11 O-ring	24 Rod	37 Ball	50 Air nipple & screen assy
12 O-ring	25 Packing	38 Retainer	51 Coupler
13 Lower valve plate	26 Piston	39 Tube	

Figure 8-4.—Continued.

---

**Section IV. TRANSFER PUMP**  
(Used on Serial Numbers 84-29943 through 84-30304 and  
86-30305 through 86-31 248)

**8-8. General**

The transfer pump is an air operated device used for transferring lubricants from original drums to the lubricant tanks.

**8-9. Transfer Pump**

*a. Removal.* Remove transfer pump (para 2-14).

*b. Disassembly.*

(1) Unscrew male adapter (40, fig. 3-5), shutoff valve (41) and adapter (42) from the power head. Loosen thumb screw (11) and remove bung adapter (12).

(2) Unscrew transfer piston and tube assembly from power head and remove cotter pin (14).

(3) Disassemble power head and transfer piston and tube assembly as shown on figure 8-5.

*c. Cleaning, Inspection and Repair.*

(1) Clean all parts using an approved cleaning solvent.

(2) Check to see that valve base (8) is clean and free from all dirt and foreign matter.

(3) Check to see that washer (1) is clean and fluctuates easily when reassembled.

(4) The two packings (3) become worn in time and should be replaced periodically.

(5) Inspect all threaded surfaces for scratches, burrs, or other defects which would prevent proper operation. If damaged, replace defective parts.

(6) Inspect pump rods and tubes for bends, breaks, or other defects which should prevent proper operation of the transfer pump.

*d. Reassembly.* Reassembly is the reverse of disassembly.

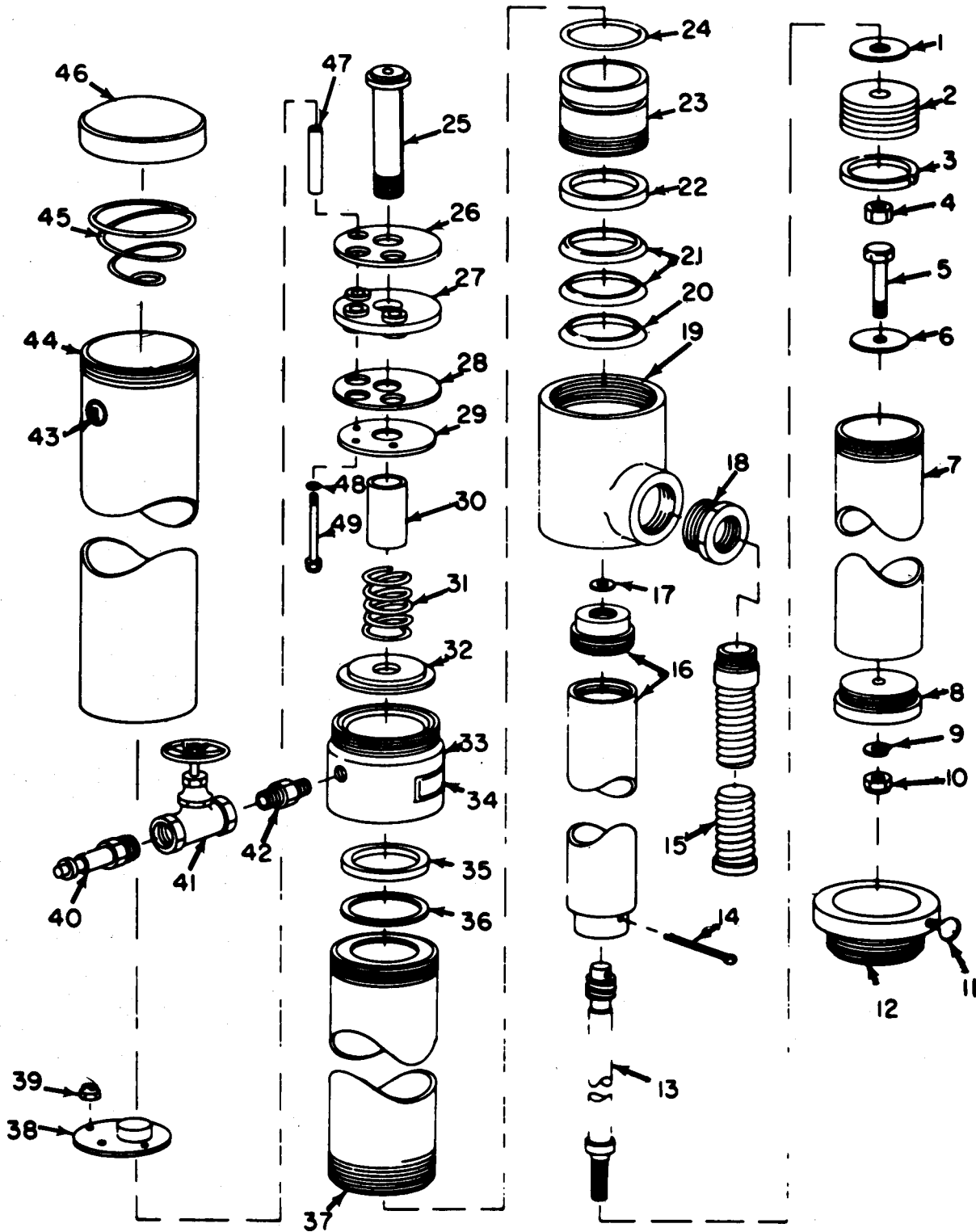

MEC 4930-217-14/8-5

Figure 8-5. Transfer pump (used only on Serial Numbers 84-29943 through 88-30304 and 86-30305 through 86-31248).

1	Washer	18	Bushing	35	Packing
2	Plunger	19	Pump casting	36	Washer
3	Packing (2)	20	Male support ring	37	Adapter assy
4	Stop Nut	21	Packing ring	38	Seal plate
5	Stud	22	Female back-up ring	39	Stop nut (3)
6	Washer	23	Bushing	40	Male adapter
7	Cylinder	24	Preformed packing	41	Shutoff valve
8	Valve base	25	Adapter	42	Adapter
9	Washer	26	Washer	43	UL Lable
10	Nut	27	Packing	44	Cylinder assy
11	Thumbscrew	28	Washer	45	Spring
12	Bung adapter	29	Washer	46	Cylinder assy
13	Rod and stop assy	30	Spacer	47	Spacer (3)
14	Cotter pin	31	Spring	48	Gasket (3)
15	Flexible hose & cap	32	Washer	49	Screw (3)
16	Piston assy	33	Adapter assy		
17	Washer	34	Nameplate		

Figure 8-5.—Continued.

---

## Section V. HOSE REEL ASSEMBLIES

### (Used an Serial Numbers 69-29737 through 69-29942)

#### 8-10. General

The hose reel bank consists of five reels and hoses mounted on a common base. Four of the hoses are used to dispense chassis, gear and engine oil. One hose is used for dispensing air under pressure. Each hose reel is equipped with a lock to prevent hoses from unreeling.

#### 8-11. Chassis, Gear and Engine Oil Reels

*a. Removal.* Refer to paragraph 3-101 and remove the reels.

*b. Disassembly.* Disassemble the hose reels in the numerical sequence as illustrated in figure 8-6.

*c. Cleaning.*

(1) Clean all parts in an approved cleaning solvent.

(2) Inspect pedestals (16) for bends, cracks, or other defects. Replace if defective.

(3) Inspect all threaded surfaces for stripped or cross threads. If beyond repair, replace.

*d. Repair.*

(1) To replace hose, pull out old hose to

its fullest extent, unscrew from outlet and attach new hose. Rewind new hose.

(2) If high pressure hose reel leaks at swivel, proceed as follows:

(a) Unscrew swivel assembly (1 through 9, fig. 8-6) from hub assembly (10) applying inward pressure on retaining nut (4) so eleven balls (2) are held in place.

*Note.* Be sure all parts are removed from inside hub.

(b) Remove steel washer (6) and packings (7 and 8). Replace packings (7 and 8) making sure packings (8) are separated and followed by packings (7).

(c) Replace steel washer (6) and spring (9). Be sure all balls (2) are in place. Replace swivel assembly in reel.

(3) If low pressure hose reel leaks at swivel, proceed as follows:

(a) Unscrew swivel from hub (10).

(b) Replace old swivel with a new one.

*e. Reassembly.* Reassemble reels in reverse of disassembly.

*f. Installation.* Refer to paragraph 3-101 for installation.

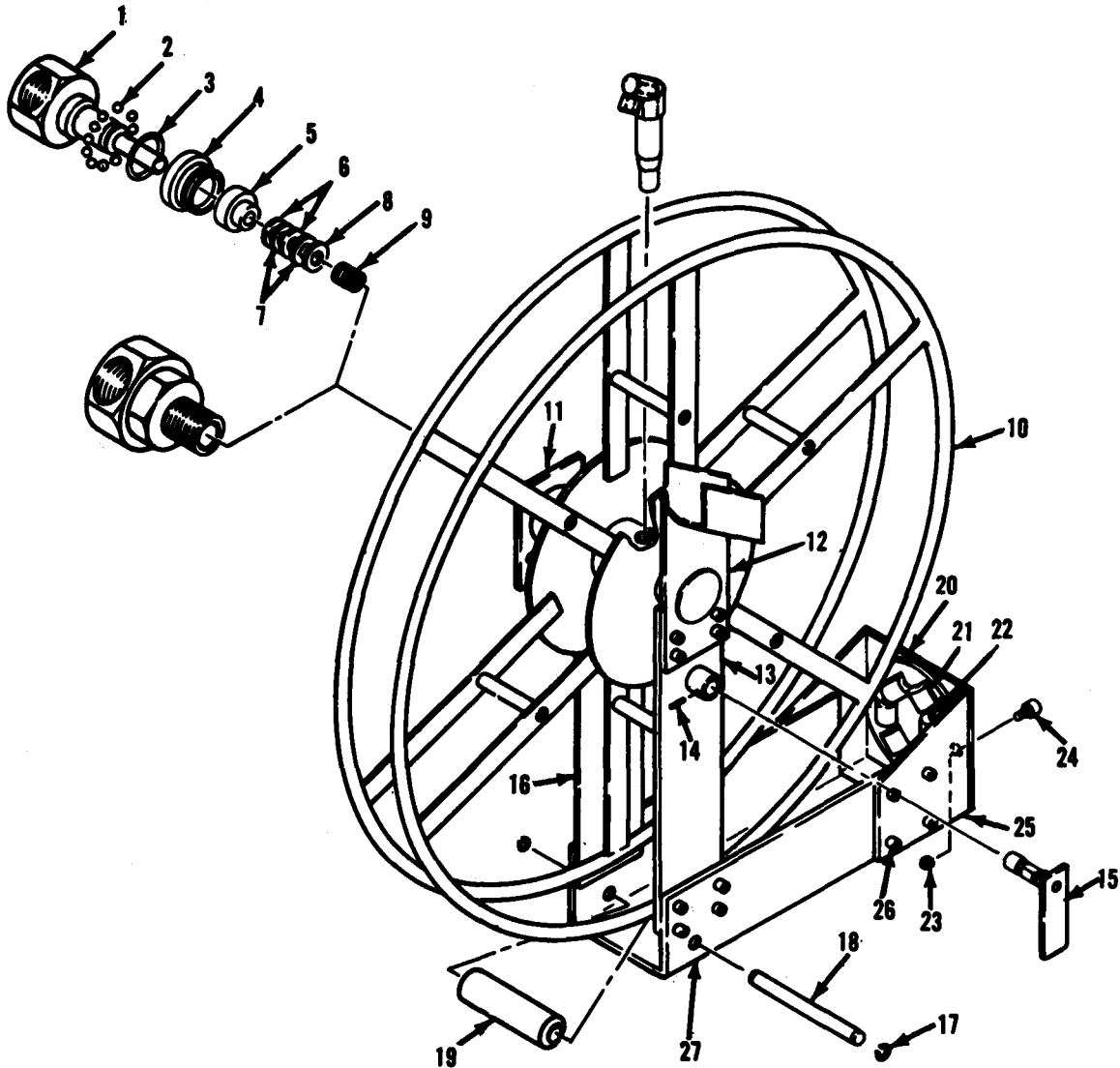

MEC 4930-217-14/8-6

- |                                |  |            |
|--------------------------------|--|------------|
| 1 Stem                         | 11 Bearing plate                                 | 19 Roller  |
| 2 Ball                         | 12 R. H. hub rail bearing and hanger subassembly | 20 Frame   |
| 3 Clip                         | 13 Pin   | 21 Roller  |
| 4 Nut                          | 14 Pin   | 22 Pin     |
| 5 Sleeve                       | 15 Lock pin & handle subassembly                 | 23 Nut     |
| 6 Washer                       | 16 Pedestal                                      | 24 Screw   |
| 7 Packing                      | 17 Ring  | 25 Bracket |
| 8 Packing                      | 18 Pin   | 26 Screw   |
| 9 Spring                       |  | 27 Base    |
| 10 H. P. hub & hose guide assy |  |            |

Figure 8-6. Chassis, gear and engine oil reels (used only on Serial Numbers 69-29737 through 69-29948).

**Section VI. HOSE REEL ASSEMBLIES**  
 (Used on Serial Numbers 84-29943 thru 84-30304 and  
 86-30305 thru 86-31248)

**8-12. General**

The hose reel bank consists of five reels and

hoses mounted on a common base. Four of the hoses are used to dispense chassis, gear and



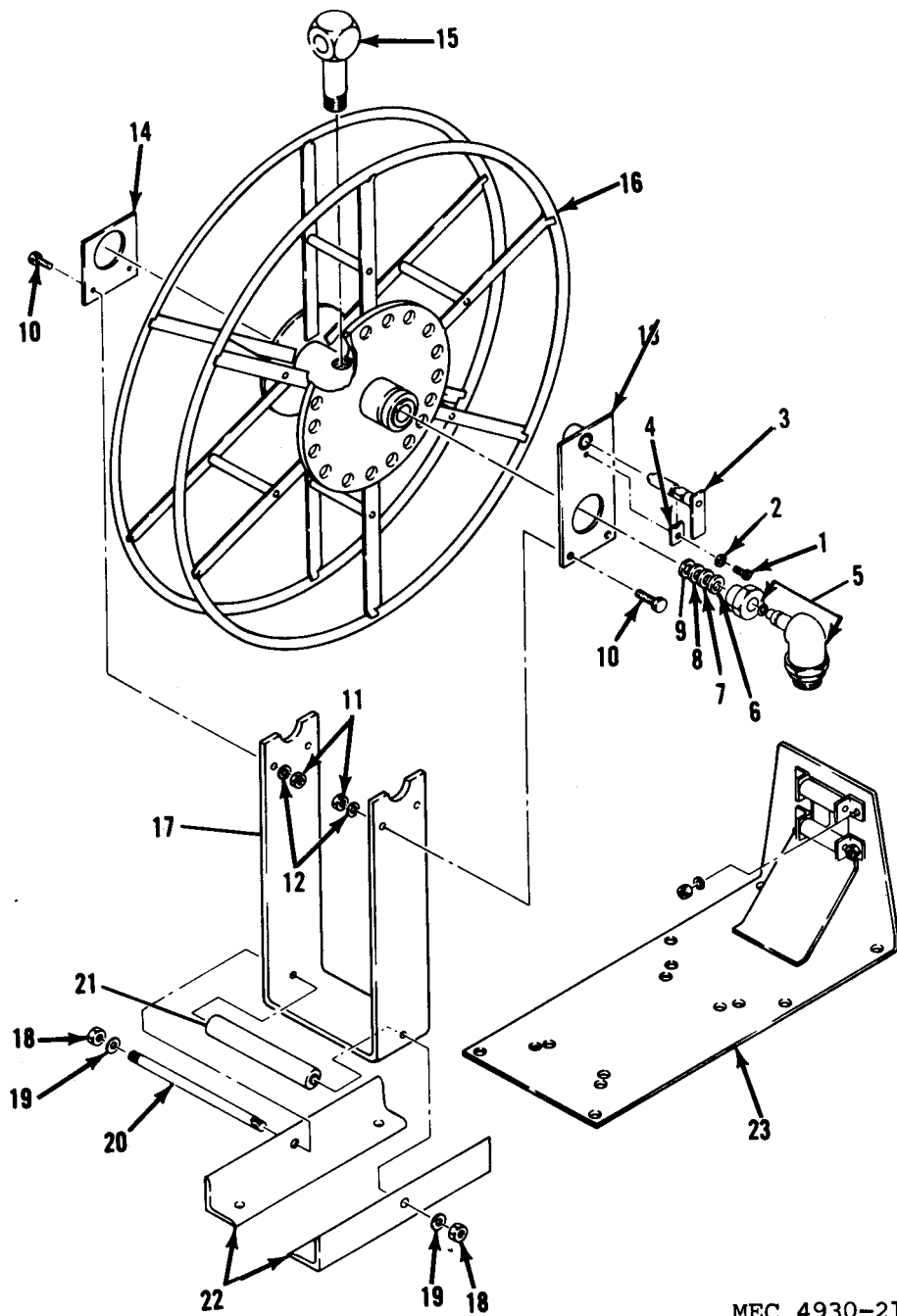

MEC 4930-217-14/8-7

- |                 |                           |                           |
|-----------------|---------------------------|---------------------------|
| 1 Screw         | 9 Male ring               | 17 Angle and frame assy   |
| 2 Lockwasher    | 10 Screw                  | 18 Nut (2)                |
| 3 Lock pin assy | 11 Nut                    | 19 Lockwasher (2)         |
| 4 Stop          | 12 Lockwasher             | 20 Stud                   |
| 5 Swivel assy   | 13 Plate and bushing assy | 21 Roller                 |
| 6 Female ring   | 14 Lock plate             | 22 Base angle             |
| 7 Leather ring  | 15 Elbow                  | 23 Hose outlet guide assy |
| 8 Packing (2)   | 16 Wheel assy             |                           |

Figure 8-7. Chassis, gear and engine oil reels (used only on Serial Numbers 84-29943 through 84-30304 and 86-30305 through 86-31248).

engine oil. One hose is used for dispensing air under pressure. Each hose reel is equipped with a lock to prevent hoses from unreeling.

### **8-13. Chassis, Gear and Engine Oil Reels**

*a. Removal.* Remove the reels as described in paragraph 8-101.

*b. Disassembly.* Disassemble the reels in numerical sequence as shown in figure 8-7.

*c. Cleaning.*

(1) Clean all parts in an approved cleaning solvent.

(2) Inspect frame (1) for bends, cracks, or other defects. Replace if defective.

(3) Inspect all threaded surfaces for stripped or cross threads. If beyond repair, replace.

*d. Repair.*

(1) To replace hose, pull out old hose to its fullest extent, unscrew from outlet and attach and rewind new hose.

(2) If hose reel leaks at swivel, remove swivel and check packing parts (6, 7, 8 and 9 of fig. 8-7).

*e. Installation.* Refer to paragraph 3-101 to install all reels.

## **Section VII. ALCOHOL DISPENSER**

### **8-14. General**

The alcohol dispenser is used to inject alcohol into the air lines leading to the lubricating pumps to prevent condensate freezeup. The alcohol dispenser is equipped with an eight ounce capacity bowl and a handle needle valve which controls the flow of alcohol.

### **8-15. Alcohol Dispenser**

*a. Removal.* Refer to paragraph 3-120 and remove the alcohol dispenser.

*b. Disassembly.* Disassemble the alcohol dis-

perser in the numerical sequence as illustrated in figure 8-8.

*c. Cleaning, Inspection and Repair.*

(1) Replace all worn or damaged parts.

(2) Clean all parts in an approved cleaning solvent.

(3) Replace all parts with those supplied in the repair kit.

*d. Reassembly.* Reassembly is the reverse of disassembly. Refer to figure 8-8 as an aid in reassembling.

*e. Installation.* Refer to paragraph 3-120.

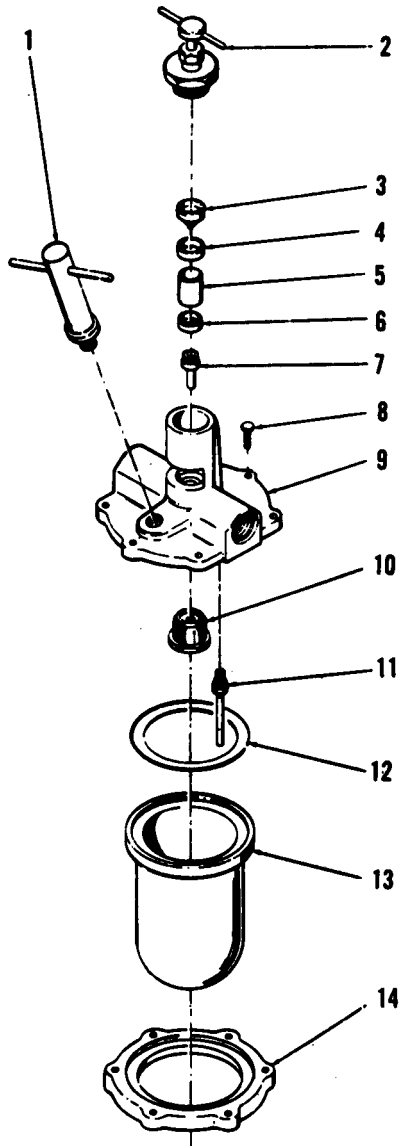

MEC 4930-217-14/8-8

- |                      |                      |               |
|----------------------|----------------------|---------------|
| 1 Filter plug assy   | 6 Lower sight gasket | 11 Tube assy  |
| 2 Needle valve assy  | 7 Venturi tube       | 12 Gasket     |
| 3 Drip               | 8 Capscrew (6)       | 13 Bowl       |
| 4 Upper sight gasket | 9 Body               | 14 Clamp ring |
| 5 Sight feed gland   | 10 Check valve assy  |               |

Figure 8-8. Alcohol dispenser—exploded view.

CHAPTER 9  
HYDRAULIC BRAKE COMPONENTS

Section I. MASTER CYLINDER

**9-1. General**

The master cylinder is located on the front

portion of the trailer frame. The master cylinder furnishes hydraulic pressure to the brakes.

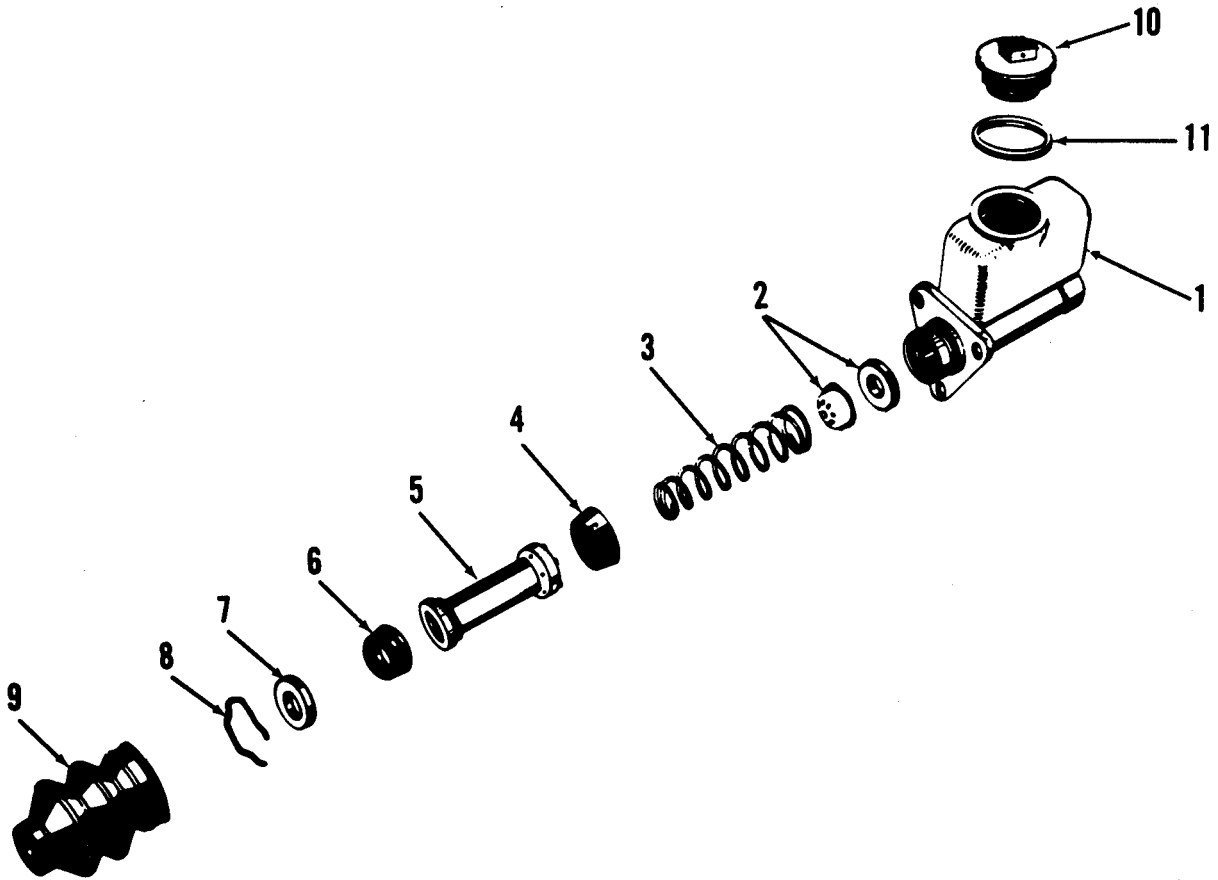

MEC 4930-217-14/9-1

- 1 Casting
- 2 Valve and seat assy
- 3 Spring

- 4 Cup
- 5 Piston assy
- 6 Cup

- 7 Plate
- 8 Wire
- 9 Boot

- 10 Cap
- 11 Gasket

Figure 9-1. Master cylinder.

## 9-2. Master Cylinder

*a. Removal.* Refer to paragraph 3-77 and remove the master cylinder.

*b. Disassembly.* Refer to figure 9-1 and disassemble the master cylinder.

*c. Cleaning, Inspection and Repair.*

(1) Clean all metal parts with an approved cleaning solvent and dry thoroughly.

(2) Clean all other parts with a clean, dry cloth.

(3) Inspect for cracks, breaks, wear, pits,

(4) Replace a damaged or defective part.

*d. Reassemble.* Refer to figure 9-1 and reassemble the master cylinder.

*e. Installation.* Install the master cylinder as described in paragraph 3-77.

## Section II. AIR RELAY VALVE

### 9-3. General

The air relay valve controls the trailer brakes and automatically applies the trailer brakes in event the trailer breaks away from the towing vehicle.

### 9-4. Air Relay Valve

*a. Removal.* Remove the air relay valve as described in paragraph 3-79.

*b. Disassembly.* Refer to figure 9-2 and disassemble the air relay valve in numerical sequence.

*c. Cleaning, Inspection and Repair.*

(1) Clean all metal parts with an approved cleaning solvent and dry thoroughly.

(2) Clean the diaphragm with a cloth dampened with an approved cleaning solvent and dry thoroughly.

(3) Inspect for cracks, breaks, wear, deterioration and other damage.

(4) Replace a damaged or defective part.

*d. Reassembly.* Refer to figure 9-2 and reassemble the air relay valve.

*e. Installation.* Install the air relay valve (para 3-79).

---

1	Emergency piston & valve assy	16	Plate	30	Piston
2	Screw	17	Washer	31	Grommet
3	Washer	18	Screw	32	Grommet
4	Valve	19	Valve	33	Cover
5	Valve	20	Screw	34	Washer
6	Grommet	21	Grommet	35	Screw
7	Piston	22	Spring	36	Tag
8	Grommet	23	Valve	37	Diaphragm
9	Grommet	24	Plug	38	Cover
10	Spring	25	Body	39	Screw
11	Grommet	26	Filter	40	Tag
12	Nut	27	Body	41	Washer
13	Shim	28	Spring	42	Plug
14	Spring	29	Ring	43	Plug
15	Gasket				

Figure 9-2. Air relay valve.

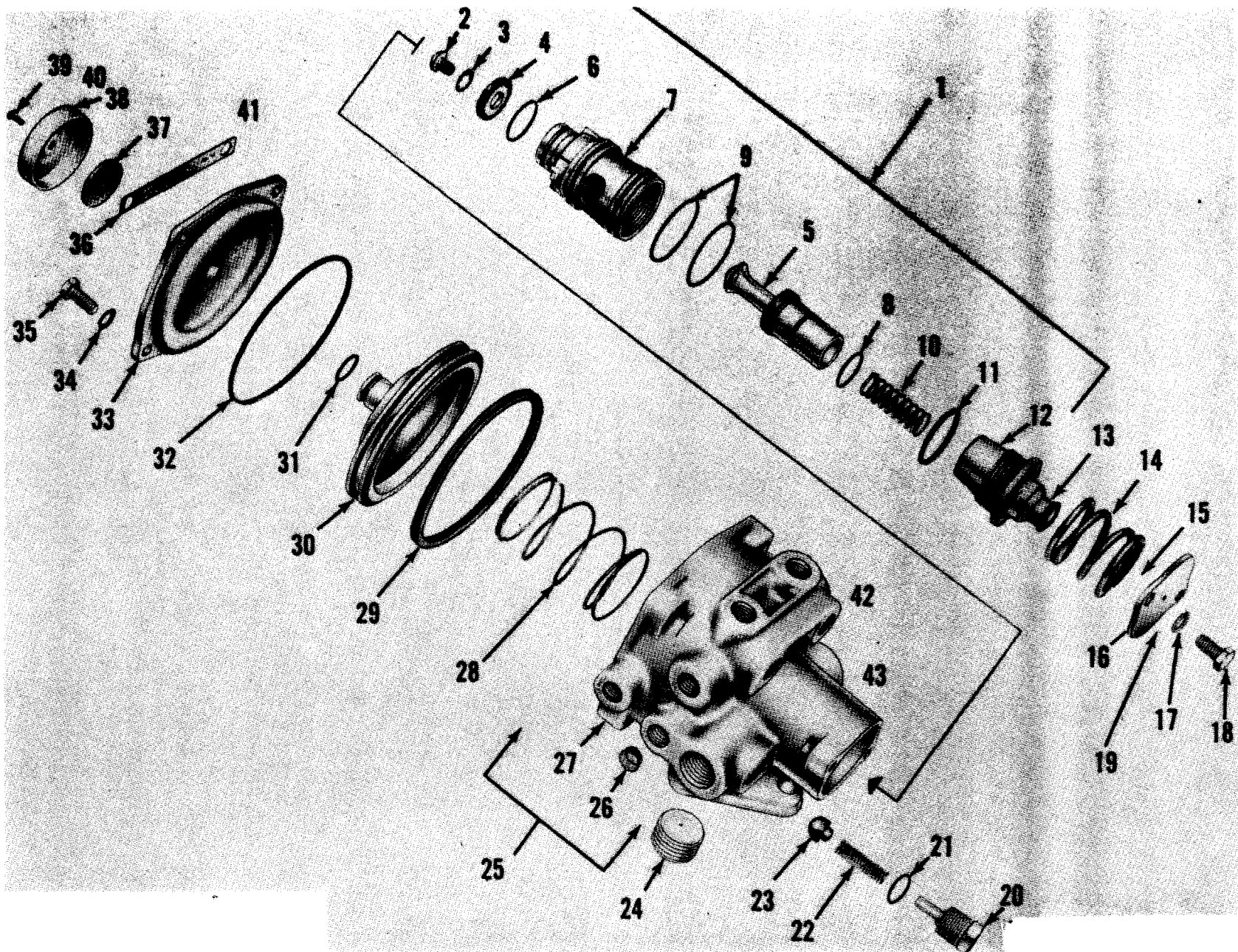

## 10-7. Base Skid

*a. Removal.* Remove the base skid as described in step (21) of paragraph 5-24a.

*b. Cleaning, Inspection and Repair.*

(1) Clean skid with approved cleaning solvent.

(2) Inspect the skid for excessive dents or broken welds.

(3) Reweld a broken weld.

(4) Replace a base skid which is beyond repair.

*c. Installation.* Installation is the reverse of removal (para 5-24 (21)).

## CHAPTER 10

### GENERAL MAINTENANCE

---

#### Section I. ENGINE

##### 10-1 . General

The engine is a four-cylinder, air-cooled, overhead valve, gasoline type which operates the compressor on the lubricating unit.

##### 10-2. Engine

*a. Removal and Installation.* Refer to paragraph 3-41 for removal and installation instructions.

*b. Repair.* Refer to TM 5-2805-203-14 for engine repair instruction.

#### Section II. TRAILER FRAME, BASE SKID, AXLE ASSEMBLY AND ENCLOSURE ASSEMBLY

##### 10-3. General

This section covers specific repair instructions for the trailer frame, the axle assembly, the base skid and the enclosure assembly.

##### 10-4. Trailer Frame

*a. Removal.* Refer to paragraph 5-24 and remove the trailer frame.

*b. Cleaning, Inspection and Repair.*

(1) Clean the frame assembly with an approved cleaning solvent and dry thoroughly.

(2) Inspect the frame for cracks, breaks, broken welds, and other damage.

(3) Straighten minor bends and reweld broken welds.

(4) Replace a frame which is damaged beyond repair.

*c. Installation.* Refer to paragraph 5-24 and install trailer frame.

##### 10-5. Axle Assembly

*a. Removal.* Refer to paragraph 5-22 for axle removal.

*b. Cleaning, Inspection and Repair.*

(1) Clean dirt and grease from all parts using an approved cleaning solvent.

(2) Check bearing and oil seal seats for roughness. Check threads on spindle for wear or damage. Using fine file, file off burrs, or hand chase if necessary. Check axle beam and spindles. Indications of bent spindles are: bearings which cannot be adjusted properly and extremely uneven wear of brake linings and tires. Spindles that are bent, but not cracked, can be straightened.

*c. Installation.* Refer to paragraph 5-22 for installation of the trailer axle.

##### 10-6. Enclosure

*a. Removal.* Refer to paragraph 3-37 for enclosure removal.

*b. Cleaning, Inspection and Repair.*

(1) Clean all parts with an approved cleaning solvent.

(2) Inspect enclosure for dents cracks, or broken welds.

(3) Reweld broken welds, and straighten dents.

(4) Replace defective or damaged hinge pins.

*c. Installation.* Refer to paragraph 3-37 for installation of the enclosure.



**APPENDIX A**  
**REFERENCES**

---

**A-1. Fire Protection**

TB 5-4200-200-10

Hand Portable Fire Extinguisher Approved for Army Users.

TM 5-687

Repair and Utilities: Fire Protection Equipment and Appliances: Inspections, Operations, and Preventive Maintenance.

**A-2. Lubrication**

C-91001-L

LO 5-4930-217-12

Fuels, Lubricants, Oils and Waxes Lubricating and Servicing Unit: Power Operated; Trailer Mounted, 23 CFM Compressor, Reciprocating Gasoline Driven (Elliot Machine Model ENG-3).

**A-3. Painting**

TM 9-213

Painting Instructions for Field Use

**A-4. Radio Suppression**

TM 11-483

Radio Interference Suppression

**A-5. Maintenance**

TM 9-1870-1

TM 38-750

TM 5-4930-217-14

Care and Maintenance of Pneumatic Tires  
Army Equipment Record Procedures.

Operator, Organization, Direct Support Maintenance Manual: Lubricating and Servicing Unit: Power Operated; Trailer Mounted, 23 CFM Compressor, Reciprocating Gasoline Driven (Elliot Machine Model ENG-3).

TM 5-4930-217-24P

Organizational, Direct Support and General Support Maintenance Repair Parts and Special Tool List; Lubricating and Servicing Unit: Power Operated; Trailer Mounted, 23 CFM Reciprocating Gasoline Driven (Elliot Machine Model ENG-3).

TM 6-2805-203-14

Operator, Organizational, Direct Support and General Support Maintenance Manual: Engine, Gasoline: Military Standard Models 4A032-1 and 4A032-11.

TM 5-2805-203-24P

Organizational, Direct Support, and General Support Maintenance Repair Parts and Spe-

TM 9-6140-200-15

**A-6. Shipment and Limited Storage**

TB 740-93-2

TB 740-93-3

cial Tool List: Engine, Gasoline: Military Standard Models 4A032-1 and 4A032-11. Operation and Organizational, Field and Depot Maintenance: Storage Batteries, Lead-Acid Type.

Preservation of USAMEC Mechanical Equipment for Shipment and Storage.  
Administrative Storage of USAMEC Mechanical Equipment.

**APPENDIX B**  
**BASIC ISSUE ITEMS LIST**  
**AND MAINTENANCE AND OPERATING SUPPLIES**

---

**Section I. INTRODUCTION**

**B-1. Scope**

This appendix lists items which accompany the Lubricating Unit or are required for installation, operation, or operator's maintenance,

**B-2. General**

This Basic Issue Items List is divided into the following sections:

*a. Basic Issue Items-Section II.* A list of items which accompany the Lubricating Unit or are required for the installation, operation, or operator's maintenance.

*b. Maintenance and Operating Supplies—Section III.* A listing of maintenance and operating supplies required for initial operation.

**B-3. Explanation of Columns**

The following provides an explanation of columns in the tabular list of Basic Issue Items, Section II.

*a. Source, Maintenance, and Recoverability Codes (SMR), Column (1):*

(1) Source Code, indicates the selection status and source for the listed item. Source code is:

<i>Code</i>	<i>Explanation</i>
P	Applied to repair parts which are stocked in or supplied from GSA/DSA or Army supply system, and authorized for use at indicated maintenance categories.

(2) Maintenance Code, indicates the lowest category of maintenance authorized to install the listed item. The maintenance level code is:

<i>Code</i>	<i>Explanation</i>
C	Operator/crew

*b. Federal Stock Number, Column (1).* This

column indicates the Federal stock number for the item.

*c. Description, Column (3).* This column indicates the Federal item name and any additional description of the item required. A part number or other reference number is followed by the applicable five-digit Federal supply code for manufacturers in parentheses. Repair parts quantities included in kits, sets, and assemblies are shown in front of the repair part name.

*d. Unit of Issue, Column (4).* This column indicates the unit used as a basis for issue, e.g., ea, pr, ft, yd, etc.

*e. Quantity Incorporated in Unit Pack, Column (5).* This column indicates the actual quantity contained in the unit pack.

*f. Quantity Incorporated in Unit, Column (6).* This column indicates the quantity of the item used in the functional group.

*g. Quantity Furnished With Equipment, Column (7).* This column indicates the quantity of an item furnished with the equipment.

*h. Quantity Authorized, Column (8).* This column indicates the quantity of an item authorized the operator/crew to have on hand or to obtain as required. As required items are indicated with an asterisk.

*i. Illustration, Column (9).* This column is divided as follows:

(1) *Figure Number, Column (9a).* Indicates the figure number of the illustration in which the item is shown.

(2) *Item Number, Column (9b).* Indicates the callout number used to reference the item in the illustration.

**B-4. Explanation of Columns in the Tabular list of Maintenance and Operating Supplies-Section III**

*a. Component Application, Column (1).* This column identifies the component application of each maintenance or operating supply item.

*b. Federal Stock Number, Column (2).* This column indicates the Federal stock number for the item and will be used for requisitioning purposes.

*c. Description, Column (3).* This column indicates the item and brief description.

*d. Quantity Required for Initial Operation, Column (4).* This column indicates the quan-

tity of each maintenance or operating supply item required for initial operation of the equipment.

*e. Quantity Required for 8 Hours Operation, Column (5).* This column indicates the estimated quantities required for an average eight hours of operation.

*f. Notes, Column (6).* This column indicates informative notes keyed to data appearing in a preceding column.

**B-5. Abbreviations**

- ea -----each
- gal -----gallon
- lb -----pound
- qt -----quart

Section II. **BASIC ISSUE ITEMS**

(1) SMR code	(2) Federal stock number	(3) Description Ref No & mfr code Useable on code		(4) Unit of issue	(5) Qty inc in unit pack	(6) Qty inc in unit	(7) Qty furn with equip	(8) Qty auth	(9) Illustration	
									(a) Fig No.	(b) Item No.
PC	7510-889-3494	GROUP 31—BASIC ISSUE ITEMS, MANUFACTURER INSTALLED 3100—BASIC ISSUE ITEMS, MANUFACTURER OR DEPOT INSTALLED BINDER, loose leaf, U.S. Army Equipment Log Book		EA			1	1		
PC	7520-599-9618	Note. Initial issue and replenishment will be made in accordance with TM 88-750 CASE, Maintenance and Operational Manuals, Cotton Duck, Water Repellent, Mildew Resistant, MIL-B-11743 Department of the Army Lubrication Order, LO 5-2805-203-14 Department of the Army, Organizational DS and GS Maintenance Manual, TM 5-2805-203-14 Department of the Army Organizational DS and GS Maintenance Manual, TM 5-4930-217-14		EA			1	1		
				EA			1	1		
				EA			1	1		
				EA			1	1		

**Section III. MAINTENANCE AND OPERATING SUPPLIES**

(1) Component application	(2) Federal stock number	(3) Description	(4) Quantity required F/initial operation	(5) Quantity required F/8 hrs operation	(6) Notes
0306 FUEL TANK	9130-160-1818	<b>FUEL, GASOLINE:</b> Bulk as follows	10 gal (4)	(5)	(1) Includes quantity of oil to fill compressor oil system as follows: 2 qt compressor. (2) See FSC C9100-1L for additional data and requisitioning procedures. (3) See current lubrication chart for grade application and replenishment intervals. (4) Tank capacity. (5) See TM 5-2805-203-14 for average fuel consumption. (6) Quantity of oil to fill oil reservoir.  (7) Quantity of gear oil to fill reservoir. (8) 2 ea—100-lb drums are required to fill grease reservoir.
	9130-160-1830	Automotive combat type I	10 gal (4)	(5)	
2207 ALCOHOL DISPENSER	6810-543-7694	<b>ALCOHOL, DENTURED:</b> 1 qt btl as follows: Alcohol	¼ qt		
5001 CRANKCASE		<b>OIL, LUBRICATING:</b> 55 gal drum as follows:			
	9150-265-9436(2)	OE-30	2 qt (1)	(3)	
	9150-265-9429(2)	OE-10	2 qt (1)	(3)	
	9150-242-7604(2)	OES	2 qt (1)	(3)	
7201 LUBRICATING OIL RESERVOIR		<b>OIL, LUBRICATING:</b> 55 gal drum as follows:			
	9150-265-9436(2)	OE-30	27 gal	(6)	
	9150-265-9429(2)	OE-10	27 gal	(6)	
	9150-242-7604(2)	OES	27 gal	(6)	
7201 LUBRICATING GEAR OIL RESERVOIR		<b>LUBRICATING OIL, GEAR:</b> 55 gal drum as follows:			
	9150-577-5845(2)	GO-90	27 gal	(7)	
	9150-257-5443(2)	GOS	27 gal	(7)	
7201 LUBRICATING GREASE RESERVOIR	9150-530-7369	<b>GREASE, AUTOMOTIVE AND ARTILLERY</b> 120 lb drum as follows: GAA	175 lb	(8)	

## APPENDIX C

### MAINTENANCE ALLOCATION CHART

---

#### Section I. INTRODUCTION

##### **C-1. General**

*a.* This section provides a general explanation of all maintenance and repair functions authorized at various maintenance levels.

*b.* Section II designates overall responsibility for the performance of maintenance functions on the identified end item or component. The implementation of the maintenance functions upon the end item or component will be consistent with the assigned maintenance functions.

*c.* Section III not applicable.

tions, explanatory notes and/or illustrations required for a particular maintenance function.

##### **C-2. Explanation of Columns in Section II**

*a.* *Group Number, Column (1).* The functional group is a numerical group set up on a functional basis. The applicable functional grouping indexes (obtained from TB 750-93-1, Functional Grouping Codes) are listed on the MAC in the appropriate numerical sequence. These indexes are normally set up in accordance with their function and proximity to each other.

*b.* *Functional Group, Column (2).* This column contains a brief description of the components of each functional group.

*c.* *Maintenance Functions, Column (3).* This column lists the various maintenance functions (A through K) and indicates the lowest maintenance category authorized to perform these functions. The symbol designations for the various maintenance categories are as follows:

C—Operator or crew

O—Organizational maintenance

F—Direct support maintenance

H—General support maintenance

The maintenance functions are defined as follows:

A—Inspect: To determine serviceability of an item by comparing its physical, mechanical, and electrical characteristics with established standards.

B—Test: To verify serviceability and to detect electrical or mechanical failure by use of test equipment.

C—Service: To clean, to preserve, to charge, to paint, and to add fuel, lubricants, cooling agents, and air.

D—Adjust: To rectify to the extent necessary to bring into proper operating range.

E—Align: To adjust specified variable elements of an item to bring to optimum performance.

F—Calibrate: To determine the corrections to be made in the readings of instruments or test equipment used in precise measurement. Consists of the comparisons of two instruments, one of which is a certified standard of known accuracy of the instrument being compared with the certified standard.

G—Install: To set up for use in an operational environment such as an emplacement, site, or vehicle.

H—Replace: To replace unserviceable items with serviceable assemblies, subassemblies, or parts.

I—Repair: To restore an item to serviceable condition. This includes, but is not limited to, inspection, cleaning, preserv-

ing, adjusting, replacing, welding, riveting, and strengthening.

J—Overhaul: To restore an item to a completely serviceable condition as prescribed by maintenance serviceability standards using the Inspect and Repair Only as Necessary (IROAN) technique.

K—Rebuild: To restore an item to a standard as nearly as possible to original or new condition in appearance, performance, and life expectancy. This is accomplished through complete disassembly of the item, inspection of all parts or components, repair or replacement of worn or unserviceable elements (items) using original manufacturing tolerances and specifications, and subsequent reassembly of the item.

e. *Remarks, Column (5).* This column is provided for referencing by code the remarks (Sec IV) pertinent to the maintenance functions.

### C-3. Explanation of Columns in Section IV

a. *Reference Code.* This column consists of two letters separated by a dash, both of which are references to Section II. The first letter references column 5 and the second letter references a maintenance function, column 3, A through K.

b. *Remarks.* This column lists information pertinent to the maintenance function being performed, as indicated on the MAC, Section II.

## Section II. MAINTENANCE ALLOCATION CHART

(1) Group No.	(2) Functional Group	(3) Maintenance functions											(4) Tools and Equipment	(5) Remarks			
		A	B	C	D	E	F	G	H	I	J	K					
		Inspect	Test	Service	Adjust	Align	Calibrate	Install	Replace	Repair	Overhaul	Rebuild					
01	<b>ENGINE</b>																
0100	Engine Assembly																
	Engine, assembly gasoline -----	C	O	C					O	F	H						A
0102	Drive Sheave -----	O							O								
0106	Engine Lubrication System																
	Hose, drain -----								O								
	Valve, drain -----								O								
	Adapter, plug -----								O								
08	<b>FUEL SYSTEM</b>																
0306	Tanks, Lines, Fittings, Headers -----																
	Cap, fuel tank -----								C								
	Lines, fittings -----								O								
	Tank, fuel -----			C					O								
	Valve, drain -----								O								
0312	Accelerator, Throttle, or Choke Control																
	Control, throttle -----				O				O								
	Control, choke -----								O								
04	<b>EXHAUST SYSTEM</b>																
0401	Muffler and Pipes																
	Valve, exhaust diverter -----								O								
06	<b>ELECTRICAL SYSTEM</b>																
0601	Generator, Alternator																
	Belt, drive -----				C				O								
	Generator assembly -----								O	F							B
	Kit, repair -----								O								

(1) Group No.	(2) Functional Group	(3) Maintenance functions											(4) Tools and equipment	(5) Remarks				
		A	B	C	D	E	F	G	H	I	J	K						
		Inspect	Test	Service	Adjust	Align	Calibrate	Install	Replace	Repair	Overhaul	Rebuild						
0602	Generator Regulator (Voltage) Control, voltage -----								O									
0603	Starting Motor Cable, starter ----- Starter assembly ----- Solenoid switch -----								O	F								C
0607	Instrument or Engine Control Panel Gage, oil pressure ----- Gage, fuel ----- Lamp, incandescent ----- Light, panel ----- Indicator, battery generator ----- Panel, control ----- Switches ----- Wiring -----								O									
0609	Lights Stop lights ----- Lamps ----- Clearance lights -----								O	O								
0610	Sending Units and Warning Switches Transmitters -----								O									
0612	Batteries, Storage (Wet or Dry) Battery, storage ----- Cables, battery ----- Trag, battery -----		O	C					O									
0613	Hull or Chassis Wiring Harness Wiring harness ----- Coupling, receptacle -----								O	O								
11	<b>REAR AXLE</b>																	
1108	Walking Beams, Stub Axles and Parts Axle assembly ----- Bearings ----- Bearing cap -----								F	F								
12	<b>BRAKES</b>																	
1202	Brakes, Service Brake assembly ----- Backing plates ----- Anchor supports and adjusted assembly ----- Return springs -----				O				F	O								
1204	Hydraulic Brake System Master cylinder assembly ----- Wheel cylinder assembly ----- Lines, fittings, hoses and clips -----			C					O	F	F							
1208	Air Brake System Lines and fittings ----- Brake chamber ----- Air filter ----- Element ----- Emergency relay valve ----- Air reservoir -----			C					O	O	O							



(1) Group No.	(2) Functional Group	(3) Maintenance functions											(4) Tools and Equipment	(5) Remarks				
		A	B	C	D	E	F	G	H	I	J	K						
		Inspect	Test	Service	Adjust	Align	Calibrate	Install	Replace	Repair	Overhaul	Rebuild						
13	<b>WHEELS AND TRACKS</b>																	
1311	Wheel Assembly																	
	Bearings -----			O					O									
	Wheels, rims, studs, seals -----								O									
1313	Tires, Tubes																	
	Tires -----			C					O									
	Tubes -----								O	O								
15	<b>FRAME, TOWING ATTACHMENTS, AND DRAWBARS</b>																	
1501	Frame Assembly																	
	Trailer frame -----								H	H								
	Base skid -----									F								
1503	Pintles and Towing Attachments																	
	Lunette -----								O									
1507	Landing Gear, Leveling Jacks (Mechanical or Hydraulic)																	
	Jack, Leveling front -----																	
16	<b>SPRINGS AND SHOCK ABSORBERS</b>																	
1601	Springs																	
	Springs, rear -----			C					O	O								
	Bumper, spring -----								O									
1604	Shock Absorber Equipment																	
	Shock absorber and studs -----								O									
18	<b>BODY, CAB, HOOD AND HULL</b>																	
1801	Body, Cab, Hood, Hull Assemblies																	
	Fenders -----								O									
1808	Stowage racks, boxes, straps, carrying cases, cable reels, hose reels, etc.																	
	Drawer, tool -----								O									
	Reels, hose -----								O	F								
1810	Cargo Body																	
	Inclosure -----								O	F								
	Lifting eye -----								O									
22	<b>BODY CHASSIS OR HULL, AND ACCESSORY ITEMS</b>																	
2202	Accessory Items																	
	Cable assembly -----								O									
	Hose assembly -----								O									
	Light and reel assembly -----								O	C								
	Lamp, incandescent -----								O									
	Chocks, wheel -----								O	C								
	Reflectors -----								O									
	Chain, safety -----								O									
2207	Winterization Equipment (Standard Vehicular Type Only)																	
	Dispenser, alcohol -----				C				O									
	Lines and fittings -----								O									
2210	Data Plates and Instruction Holders																	
	Plates, data C.O.E. -----								O	F								
	Plates, instruction and caution -----								O									
47	<b>GAGES (NON-ELECTRICAL) WEIGHING AND MEASURING DEVICES</b>																	

(1) Group No.	(2) Functional Group	(3) Maintenance functions											(4) Tools and Equipment	(5) Remarks				
		A	B	C	D	E	F	G	H	I	J	K						
		Inspect	Test	Service	Adjust	Align	Calibrate	Install	Replace	Repair	Overhaul	Rebuild						
4702	Gages, Mountings, Lines and Fittings																	
	Gage, air pressure -----																O	
	Lines and fittings -----																O	
4705	Flow Meters and Regulations																	
	Control, air -----																O	F
	Regulator, pressure -----																O	F
50	PNEUMATIC EQUIPMENT																	
5000	Air Compressor Assembly																	
	Air compressor assembly -----	C		C													O	F
5001	Crankcase, Bloc, Cylinder Head																	
	Crankcase -----																F	F
	Cylinder -----																F	F
	Head, cylinder -----																F	F
5006	Lubrication System																	
	Plug, drain -----																O	
5007	Compressor Drive																	
	Belts, drive -----					C											O	
	Guard, belt -----																O	
	Flywheel -----																O	
5008	Air Intakes																	
	Cleaner, air -----					C											O	
5009	Unloader System Components																	
	Body cover, governor -----																F	
	Lines -----																F	
	Manifold -----																F	
	Plunger, spring, ball -----																F	
	Spring—sleeve governor -----																F	
	Spindle, governor -----																F	
	Valve, safety relief -----																F	F
	Valve, check -----																F	F
	Weight, control -----																F	F
5010	Compressor Cooling and Heating																	
	Inter cooler -----																O	
	Valve, safety -----																F	
5012	Throttling Devices																	
	Cylinder -----																O	
	Tube and fittings -----																O	
	Valve, throttle -----																O	
5014	Air Receiver Tank																	
	Cock, drain -----																O	
	Receiver, air -----					O											F	
5015	Air Discharge System																	
	Hose -----																O	
	Valve, relief -----																O	
	Valve, master air -----																O	
72	DISPENSING AND SERVICING EQUIPMENT COMPONENTS																	
7201	Lubricating Equipment																	
	Gun, power -----																O	F
	Gun, lever -----																O	F
	Gun, oil -----																O	F

(1) Group No.	(2) Functional Group	(3) Maintenance Operations											(4) Tools and Equipment	(5) Remarks			
		A	B	C	D	E	F	G	H	I	J	K					
		Inspect	Test	Service	Adjust	Align	Calibrate	Install	Replace	Repair	Overhaul	Rebuild					
7201	Lubricating Equipment (Cont'd)																
	Gun, suction -----											O					
	Gun, spray, air operated -----											O					
	Pneumatic gun -----											O					
	Portable lubricator -----											O					
	Reservoir, oiler hand operated -----											O					
7202	Pumps and Gage																
	Gage -----											O					
	Pumps -----			C								O	F				
7203	Valves, Fittings, Lines																
	Regulator, air -----											O	O				
	Valve, control (high & low pressure control metering control valve) -----											O	O				
76	<b>FIRE FIGHTING EQUIPMENT COMPONENTS</b>																
7603	Fire Extinguishers																
	Extinguisher, fire -----												C				

**Section IV. REMARKS**

Reference Code	Remarks
A-H	For Maintenance Allocation Chart relative to the Military Standard Engine Model 4A032-1 and II, refer to TM 5-2805-203-14.
B-I	Repair of generator includes replacement bearings.
C-I	Repair of starter includes installing repair kit.
C-I	Repair of pump includes installing repair kit.

## INDEX

	Paragraph	Page		Paragraph	Page
Accessory equipment .....	2-27	2-15	Description .....	1-3	1-1
Adjust drive sheave .....	3-53	3-16	Difference in models .....	1-5	1-6
Air:			Dismantling for movement .....	2-6	2-4
Compressor .....	3-10	3-7	Dispenser, alcohol, maintenance .....	3-120	3-48
	3-97	3-36	Dispenser, alcohol, operation .....	2-30	2-16
	7-2	7-1	Dispensing lubricants .....	2-16	2-11
Filter .....	3-81	3-28	Diverter, exhaust .....	3-50	3-16
Gauge .....	3-115	3-46	Drain valve, fuel tank .....	3-46	3-14
Hoses, intervehicular .....	3-91	3-33	Drawer, battery .....	3-38	3-11
Pneumatic gun .....	3-113	3-45	Drive belt compressor .....	3-94	3-34
Pressure relief valve .....	3-117	3-48	Drive belt guard .....	3-93	3-34
Pressure gauge .....	3-115	3-46	Drive pulley, compressor .....	3-95	3-34
Regulators .....	3-115	3-46	Drive sheave .....	3-62	3-16
System components .....	3-92	3-34		3-53	3-16
Tank receiver .....	5-23	5-4	Dusty or sandy area operation .....	2-20	2-13
	3-118	3-48			
Valve, master air .....	3-120	3-48	Enclosure Assembly .....	3-37	3-11
Alcohol dispenser, maintenance---	3-9	3-6	Engine .....	3-41	3-12
	3-120	3-48	Equipment:		
Alcohol dispenser, operation .....	2-30	2-16	Accessory .....	2-27	2-15
Repair .....	2-30	2-16	Basic issue .....	3-2	3-1
			Servicing and inspection .....	2-3	3-1
Basic issue tools and equipment .....	3-2	3-1	Special .....	3-1	3-1
Battery-Generator indicator .....	3-59	3-17	Starting .....	2-11	2-8
Batteries .....	3-15	3-8	Stopping .....	2-12	2-8
Battery drawer.....	3-38	3-11	Unloading .....	2-1	2-1
Belt, compressor drive .....	3-94	3-34	Unpacking .....	2-2	2-1
Brakes .....	3-16	3-8	Winterization .....	3-120	3-48
Bypass switch .....	3-61	3-17	Extinguisher .....	3-22	3-10
			Extreme cold operation .....	2-18	2-12
Choke control .....	3-48	3-16	Extreme heat operation .....	2-19	2-13
Cap, fuel .....	3-44	3-14			
Components:			Faulty lubricant delivery .....	3-28	3-10
Air System .....	3-92	3-34	Filling lubricant tanks .....	2-14	2-9
Compressor:			Fire extinguisher, carbon diox-		
Air .....	3-97	3-36	ide type .....	3-22	3-10
Drive belt adjustment .....	3-10	3-7	Filler brake air line .....	3-81	3-28
Drive belt .....	3-94	3-34	Forms, record and report .....	1-2	1-1
Drive belt guard .....	3-93	3-34	Fuel gague, operation .....	2-9	2-5
Drive pulley .....	3-95	3-34	Fuel tank and components .....	3-43	3-14
Oil drain .....	3-99	3-37			
Overheats .....	3-24	3-10	Gauge:		
Noisy .....	3-25	3-10	Air pressure .....	3-115	3-46
Pumps too slowly or fills to			Air receiver pressure .....	3-117	3-48
build up pressure .....	3-26	3-10	Battery-Generator .....	3-59	3-17
Belief valve .....	3-117	3-48	Fuel .....	3-59	3-17
V-belts worn excessively .....	3-27	3-10	Oil pressure .....	2-9	2-5
Controls and instruments .....	2-9	2-5	Gear, landing .....	3-83	3-29
			General lubrication information .....	3-3	3-1
Daily preventive maintenance			Generator .....	6-2	6-1
services .....	3-6	3-3	Generator drive belt, adjustment -	3-14	3-8
Detailed lubrication information .....	3-4	3-1	Guard, compressor drive belt .....	3-94	3-34

	Paragraph	Page		Paragraph	Page
Handguns -----	2-24	2-14	Operation—Continued		
High altitude operation _____	2-22	2-14	Under rainy or humid condi-		
High pressure chassis control _____	3-102	3-37	tions -----	2-21	2-14
	3-107	3-44	Under usual conditions _____	2-13	2-3
Hose reels do not turn properly _____	3-31	3-11	Overheated compressor _____	3-24	3-10
Hub, wheel bearing, brakedrum -	3-73	3-22			
Identification and tabulated data_	1-4	1-4	Panel lights _____	3-60	3-17
Ignition switch _____	3-61	3-17	Preparing lubricant pumps for		
Improper operation of lubricant			operation _____	2-16	2-9
pump _____	3-29	3-10	Pressure:		
Indicator gauge, battery-gener-			Gauge, air _____	3-115	3-46
ator _____	3-69	3-17	Gauge, air receiver -----	3-117	3-48
Inspecting and servicing equip-			Relief valve -----	3-117	3-48
ment _____	2-3	2-1	Preventive maintenance services:		
Installation of separately packed			Daily _____	3-6	3-6
components _____	2-4	2-1	Quarterly _____	3-7	3-6
Installation or setting-up in-			Procedure for shutdown _____	2-17	2-12
structions _____	2-5	2-4	Pulley, compressor drive _____	3-96	3-34
Instruments and controls -----	2-9	2-5	Pump, lubricant -----	3-114	3-45
Insufficient pressure or volume			High pressure _____	8-2	8-1
with pump operating _____	3-30	3-10		8-5	8-5
Intervehicular air hoses -----	3-91	3-33	Low pressure -----	8-3	8-3
				8-5	8-5
Landing gear -----	3-83	3-29		8-7	8-13
Lamps _____	3-20	3-8	Pump, transfer -----	8-9	8-15
	3-21	3-8			
Lights, panel _____	3-60	3-17	Quarterly, preventive mainte-		
Lubricant:			nance services -----	3-7	3-6
Delivery faulty _____	3-28	3-10	Rainy or humid condition opera-		
Dispensing instructions _____	2-16	2-11	tion _____	2-21	2-14
Pump fails to operate prop-			Record and report forms _____	1-2	1-1
erly -----	3-29	3-10	Reel assemblies -----	8-11	8-17
Pump _____	3-114	3-45	Regulators, air -----	8-13	8-20
Pumps, preparation for oper-			Regulator, voltage _____	3-115	3-46
ation -----	2-15	2-9	Relief valve, compressor -----	6-2	6-1
Tank, filling _____	2-14	2-9	Reinstallation after movement _____	3-117	3-48
Lubrication, detailed informa-			Report forms _____	2-7	2-4
tion _____	3-4	3-1	Repair alcohol dispenser -----	3-15	8-20
Lubrication, general information _____	3-3	3-1			
Maintenance:			Salt water area operation -----	2-22	2-14
Daily preventive -----	3-6	3-6	Scope -----	1-1	1-1
Operators _____	3-8	3-6	Sending units _____	3-67	3-19
Preventive _____	3-5	3-1	Separately packed components,		
Quarterly preventive _____	3-7	3-6	installation _____	2-4	2-1
Master air valve _____	3-120	3-48	Service brakes -----	3-76	3-23
Metered control _____	3-106	3-40	Service and inspection equip-		
	3-107	3-44	ment _____	2-3	2-1
Model difference _____	1-5	1-5	Setting up instructions _____	2-5	2-4
Movement, dismantling for _____	2-6	2-4	Sheave, drive -----	3-52	3-16
Noisy compressor _____	3-25	3-10		3-53	3-16
Operation:			Shutdown procedure _____	2-17	2-12
In dusty or sandy areas _____	2-20	2-13	Special tools and equipment _____	3-1	3-1
In extreme cold -----	2-18	2-12	Spray gun, oil, air operated _____	3-112	3-44
In extreme heat _____	2-19	2-13	Starter _____	6-4	6-4
In high altitude _____	2-23	2-14	Start switch -----	3-61	3-17
In salt water areas _____	2-22	2-14	Starting the equipment _____	2-11	2-8
Starting _____	2-11	2-3	Stopping the equipment _____	2-12	2-8
Stopping _____	2-12	2-8	Switch:		
			Bypass _____	3-61	3-17
			Ignition _____	3-61	3-17
			start -----	3-61	3-17

	<b>Paragraph</b>	<b>Page</b>		<b>Paragraph</b>	<b>Page</b>
Tabulated data -----	1-4	1-4	V-belts worn excessive, compres-		
Tank filling, lubricant -----	2-14	2-9	sor -----	3-27	3-10
Tool box -----	3-39	3-12	Valve:		
Tools :			Air, master -----	3-120	3-48
Basic issue -----	3-2	3-1	Valve (Cent):		
Special -----	3-1	3-1	High pressure control chassis -	3-106	3-40
Trailer brakes -----	3-16	3-8	Metered control -----	3-107	3-44
Transfer pumps -----	8-7	8-13	Relief, compressor -----	3-117	3-48
	8-9	8-15	Voltage regulator -----	6-2	6-1
Unloading the equipment -----	2-1	2-1	Wheels -----	3-72	3-21
Unpacking equipment -----	2-2	2-1	Winterization equipment -----	3-120	3-48

By Order of the Secretary of the Army:

HAROLD K. JOHNSON,  
*General, United States Army,*  
*Chief of Staff.*

*Official:*

KENNETH G. WICKHAM,  
*Major General, United States Army,*  
*The Adjutant General.*

Distribution:

**To be distributed in accordance with DA Form 12-25, Sec I requirements for Organizational maintenance, Lubricating and Servicing.**



# SOMETHING WRONG WITH THIS MANUAL?

THEN... JOT DOWN THE DOPE ABOUT IT ON THIS FORM. TEAR IT OUT, FOLD IT AND DROP IT IN THE MAIL!

FROM: (YOUR UNIT'S COMPLETE ADDRESS)

PFC JOHN DOE  
CoA, 3<sup>rd</sup> ENGINEER BN  
FT. LEONARD WOOD MO 63108

DATE 16 DEC 74

PUBLICATION NUMBER

TM5-6115-200-20 AND P

DATE

1 APR 72

TITLE

GENERATOR SET 10 KW  
NSN 6115-00-231-7286

BE EXACT... PIN-POINT WHERE IT IS

IN THIS SPACE TELL WHAT IS WRONG AND WHAT SHOULD BE DONE ABOUT IT:

PAGE NO.	PARA-GRAPH	FIGURE NO.	TABLE NO.
6	2-1 a		
81		4-3	
125	line 20		

In line 6 of paragraph 2-1a the manual states the engine has 6 cylinders. The engine on my set only has 4 cylinders. Change the manual to show 4 cylinders

Callout <sup>D</sup> on figure 4-3 is pointing at a bolt. In the key to fig. 4-3, item 16 is called a shim. Please correct one or the other.

I ordered a gasket, item 19 on figure B-16 by NSN 2910-00-762-3001. I got a gasket but it doesn't fit. Supply says I got what I ordered so the NSN is wrong. Please give me a good NSN

TYPED NAME, GRADE OR TITLE, AND TELEPHONE NUMBER

JOHN DOE, PFC (268) 317-7111

SIGN HERE:

John Doe

DA FORM 2028-2 (TEST) 1 AUG 74

P.S.--IF YOUR OUTFIT WANTS TO KNOW ABOUT YOUR MANUAL "FIND" MAKE A CARBON COPY OF THIS AND GIVE IT TO YOUR HEADQUARTERS.

TEAR ALONG DOTTED LINE





FILL IN YOUR  
UNIT'S ADDRESS

FOLD BACK

DEPARTMENT OF THE ARMY

OFFICIAL BUSINESS

Commander  
U.S. Army Troop Support Command  
ATTN: AMSTS-MPP  
4300 Goodfellow Boulevard  
St. Louis, Missouri 63120

TEAR ALONG DOTTED LINE

FOLD BACK

# THE METRIC SYSTEM AND EQUIVALENTS

## WEIGHT MEASURE

1 Centimeter = 10 Millimeters = 0.01 Meters = 0.3937 Inches  
 1 Meter = 100 Centimeters = 1000 Millimeters = 39.37 Inches  
 1 Kilometer = 1000 Meters = 0.621 Miles

## WEIGHTS

1 Gram = 0.001 Kilograms = 1000 Milligrams = 0.035 Ounces  
 1 Kilogram = 1000 Grams = 2.2 lb.  
 1 Metric Ton = 1000 Kilograms = 1 Megagram = 1.1 Short Tons

## LIQUID MEASURE

1 Milliliter = 0.001 Liters = 0.0338 Fluid Ounces  
 1 Liter = 1000 Milliliters = 33.82 Fluid Ounces

## SQUARE MEASURE

1 Sq. Centimeter = 100 Sq. Millimeters = 0.155 Sq. Inches  
 1 Sq. Meter = 10,000 Sq. Centimeters = 10.76 Sq. Feet  
 1 Sq. Kilometer = 1,000,000 Sq. Meters = 0.386 Sq. Miles

## CUBIC MEASURE

1 Cu. Centimeter = 1000 Cu. Millimeters = 0.06 Cu. Inches  
 1 Cu. Meter = 1,000,000 Cu. Centimeters = 35.31 Cu. Feet

## TEMPERATURE

$5/9(^{\circ}\text{F} - 32) = ^{\circ}\text{C}$   
 212° Fahrenheit is equivalent to 100° Celsius  
 90° Fahrenheit is equivalent to 32.2° Celsius  
 32° Fahrenheit is equivalent to 0° Celsius  
 $9/5^{\circ}\text{C} + 32 = ^{\circ}\text{F}$

## APPROXIMATE CONVERSION FACTORS

TO CHANGE	TO	MULTIPLY BY
Inches	Centimeters	2.540
Feet	Meters	0.305
Yards	Meters	0.914
Miles	Kilometers	1.609
Square Inches	Square Centimeters	6.451
Square Feet	Square Meters	0.093
Square Yards	Square Meters	0.836
Square Miles	Square Kilometers	2.590
Acres	Square Hectometers	0.405
Cubic Feet	Cubic Meters	0.028
Cubic Yards	Cubic Meters	0.765
Fluid Ounces	Milliliters	29.573
its	Liters	0.473
arts	Liters	0.946
allons	Liters	3.785
Ounces	Grams	28.349
Pounds	Kilograms	0.454
Short Tons	Metric Tons	0.907
Pound-Feet	Newton-Meters	1.356
Pounds per Square Inch	Kilopascals	6.895
Miles per Gallon	Kilometers per Liter	0.425
Miles per Hour	Kilometers per Hour	1.609

TO CHANGE	TO	MULTIPLY BY
Centimeters	Inches	0.394
Meters	Feet	3.280
Meters	Yards	1.094
Kilometers	Miles	0.621
Square Centimeters	Square Inches	0.155
Square Meters	Square Feet	10.764
Square Meters	Square Yards	1.196
Square Kilometers	Square Miles	0.386
Square Hectometers	Acres	2.471
Cubic Meters	Cubic Feet	35.315
Cubic Meters	Cubic Yards	1.308
Milliliters	Fluid Ounces	0.034
Liters	Pints	2.113
Liters	Quarts	1.057
ers	Gallons	0.264
ms	Ounces	0.035
ograms	Pounds	2.205
Metric Tons	Short Tons	1.102
Newton-Meters	Pounds-Feet	0.738
Kilopascals	Pounds per Square Inch	0.145
ometers per Liter	Miles per Gallon	2.354
ometers per Hour	Miles per Hour	0.621

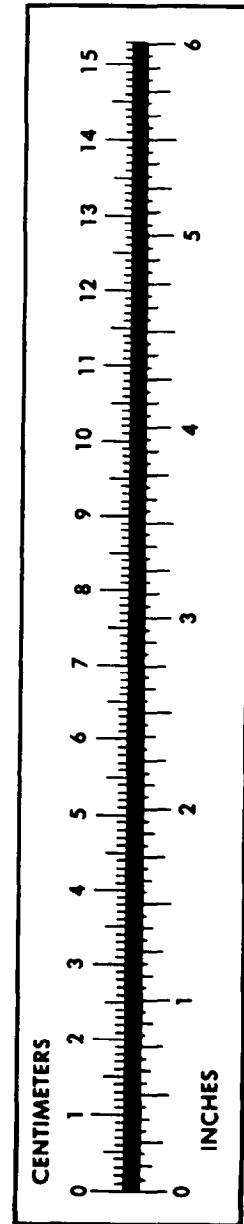

**PIN: 005954-005**